

Model No.: LV600HH

levoit

Hybrid Ultrasonic Humidifier

EN

ES

FR

Questions or Concerns?

Please contact us Mon–Fri, 9:00 am–5:00 pm PST/PDT
at support@levoit.com or at **(888) 726-8520**.

READ AND SAVE THESE INSTRUCTIONS

EN TABLE OF CONTENTS

Specifications	2
Package Contents	3
Safety Information	5
Operation	6
LED Display	7
Button Controls	8
Getting Started	9
Using Your Humidifier	10
Using the Aroma Box	11
Preventing Water Leak	12
Keeping Things Clean	13
• General Cleaning	13
• Cleaning the Aroma Pad	14
• Replacing the Remote Control Battery	14
• Disinfecting the Humidifier	14
Troubleshooting	15
Warranty Information	17
Customer Support	17

SPECIFICATIONS

Power Supply	AC 120V, 60Hz
Rated Power	280W
Effective Range	430–753 ft ² (40–70 m ²)
Water Tank Capacity	1.5 gal (5.6 L)
Max Cool Mist Output	300 mL/h
Max Warm Mist Output	500 mL/h

ES TABLE OF CONTENTS

Specifications	
Package Contents	
Safety Information	
Operation	
LED Display	
Button Controls	
Getting Started	
Using Your Humidifier	
Using the Aroma Box	
Preventing Water Leak	
Keeping Things Clean	
• General Cleaning	
• Cleaning the Aroma Pad	
• Replacing the Remote Control Battery	
• Disinfecting the Humidifier	
Troubleshooting	
Warranty Information	
Customer Support	

SPECIFICATIONS

Power Supply	AC 120V, 60Hz
Rated Power	280W
Effective Range	430–753 ft ² (40–70 m ²)
Water Tank Capacity	1.5 gal (5.6 L)
Max Cool Mist Output	300 mL/h
Max Warm Mist Output	500 mL/h

FR TABLE OF CONTENTS

Specifications
Package Contents
Safety Information
Operation
LED Display
Button Controls
Getting Started
Using Your Humidifier
Using the Aroma Box
Preventing Water Leak
Keeping Things Clean

- General Cleaning
- Cleaning the Aroma Pad
- Replacing the Remote Control Battery
- Disinfecting the Humidifier

Troubleshooting
Warranty Information
Customer Support

SPECIFICATIONS

Power Supply	AC 120V, 60Hz
Rated Power	280W
Effective Range	430–753 ft ² (40–70 m ²)
Water Tank Capacity	1.5 gal (5.6 L)
Max Cool Mist Output	300 mL/h
Max Warm Mist Output	500 mL/h

EN PACKAGE CONTENTS

1 x Hybrid Ultrasonic Humidifier
1 x Remote Control
1 x 3V CR2025 Battery (Pre-Installed)
2 x Aroma Pads (1 Pre-Installed)
2 x Absorption Pads (1 Pre-Installed)
1 x Cleaning Brush
1 x User Manual

ES PACKAGE CONTENTS

1 x Hybrid Ultrasonic Humidifier
1 x Remote Control
1 x 3V CR2025 Battery (Pre-Installed)
2 x Aroma Pads (1 Pre-Installed)
2 x Absorption Pads (1 Pre-Installed)
1 x Cleaning Brush
1 x User Manual

FR PACKAGE CONTENTS

1 x Hybrid Ultrasonic Humidifier
1 x Remote Control
1 x 3V CR2025 Battery (Pre-Installed)
2 x Aroma Pads (1 Pre-Installed)
2 x Absorption Pads (1 Pre-Installed)
1 x Cleaning Brush
1 x User Manual

EN

Hybrid Ultrasonic Humidifier

Model No.: LV600HH

THANK YOU FOR PURCHASING THE LV600HH HYBRID ULTRASONIC HUMIDIFIER BY LEVOIT.

If you have any questions or concerns, please reach out to us at support@levoit.com. We hope you enjoy your new air purifier!

SHARE THE LEVOIT LOVE

Find @LevoitLifestyle on social media for wellness + style inspiration. We make every space mindful and chic.

[@LevoitLifestyle](#)

[#LevoitLove](#) · [#LevoitLifestyle](#)

SAFETY INFORMATION

To reduce the risk of fire, electric shock, or other injury, follow all instructions and safety guidelines.

General Safety

- **Only** use this humidifier as described in this manual.
- Place the humidifier and cord so that the humidifier will not be knocked over.
- When not in use, turn the machine off and disconnect from power source by removing the plug from the outlet.
- **Do not** overfill the water tank, as this may cause electric shock.
- **Do not** use this humidifier in wet environments.
- Keep the humidifier out of reach from children.
- **Do not** open the base or remove the water level sensor for self-servicing.
- **Always** unplug your humidifier from the power outlet before cleaning your humidifier or detaching the water tank from the humidifier base.
- **Always** make sure to place the humidifier on a flat, level surface before operation.
- **Only** fill the water tank with clean water. **Never** fill the water tank with any other liquids.
- **Do not** place the humidifier near sources of heat, such as stove tops, ovens, or radiators.
- **Do not** place the humidifier directly on floors, carpets, or rugs.
- **Do not** use attachments that are not recommended by the manufacturer as replacement parts for this humidifier.
- **Do not** cover the nozzle while the humidifier is on. Doing so may damage the humidifier.
- Remove the water tank from the base before moving the humidifier.
- **Do not** immerse the humidifier base, power cord, or plug in water.
- **Do not** add essential oils, supplemental water treatment liquids, or additional water filters into the water tank.
- If the humidifier is damaged or is not functioning properly, stop using it and contact **Customer Support** immediately (see page 17).

Plug and Cord

- Ensure that the plug fits properly into a polarized socket.
- **Do not** handle the power cord or plug with wet hands. Keep the plug and power cord away from liquids.
- Your humidifier has a polarized plug (one prong is wider than the other), which fits into a polarized outlet only one way. This is a safety feature to reduce the risk of electric shock. If the plug does not fit, reverse the plug. If it still does not fit, **do not** use the plug in that outlet. **Do not** bypass this safety feature.

Not for commercial use. Household use only.

**READ AND
SAVE THESE
INSTRUCTIONS**

GETTING TO KNOW YOUR HUMIDIFIER

- A. Nozzle Cap
- B. Nozzles
- C. Handle
- D. Water Tank
- E. Base
- F. Aroma Box
- G. LED Display
- H. Control Panel
- I. Remote Control
- J. Mist Tube
- K. Mist Channel
- L. Absorption Pad
- M. Inner Chamber
- N. Power Cord
- O. Water Tank Cap

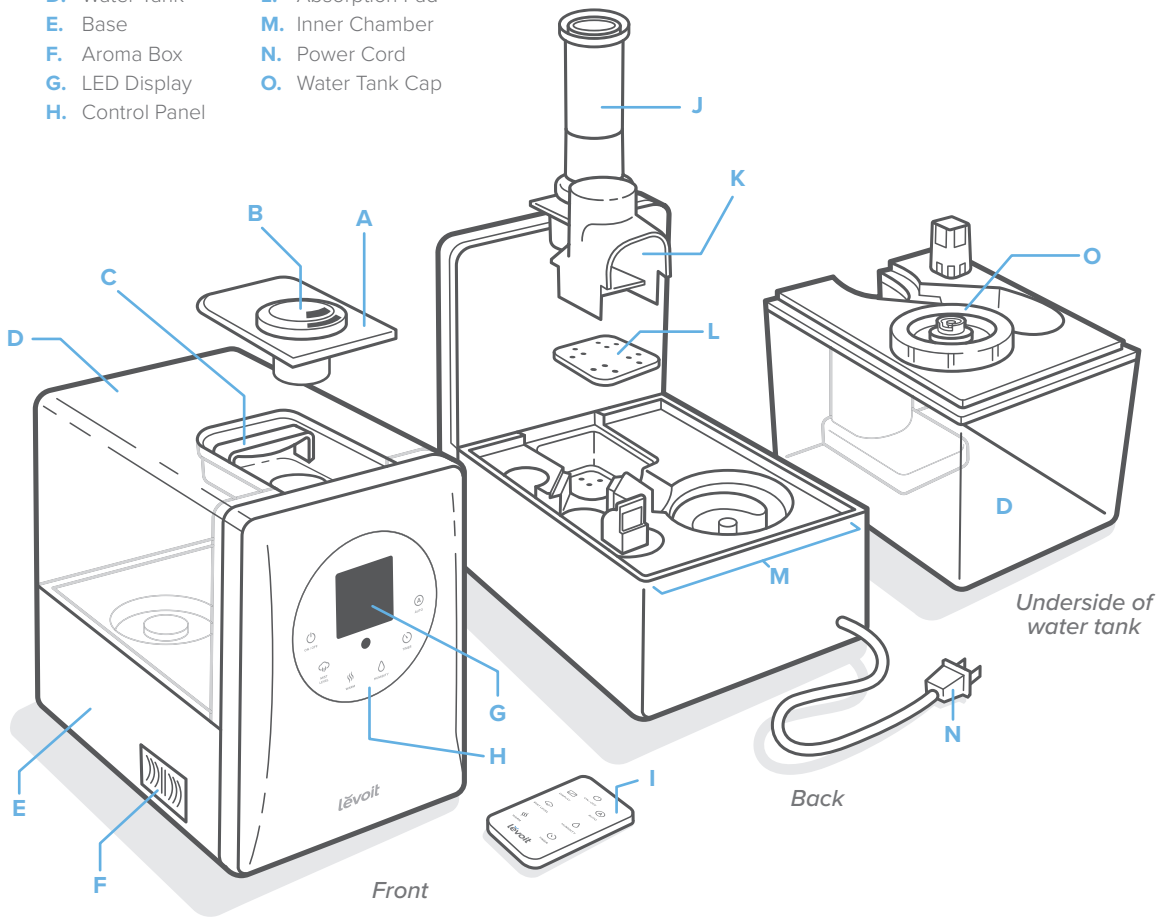

Underside of water tank

Back

Front

LED DISPLAY

- A. High Temperature Warning
- B. Set Humidity Function
- C. Relative Humidity (RH) Level
- D. Mist Level
- E. Timer
- F. Warm Mist Setting
- G. Auto Mode Indicator
- H. Low Water Indicator

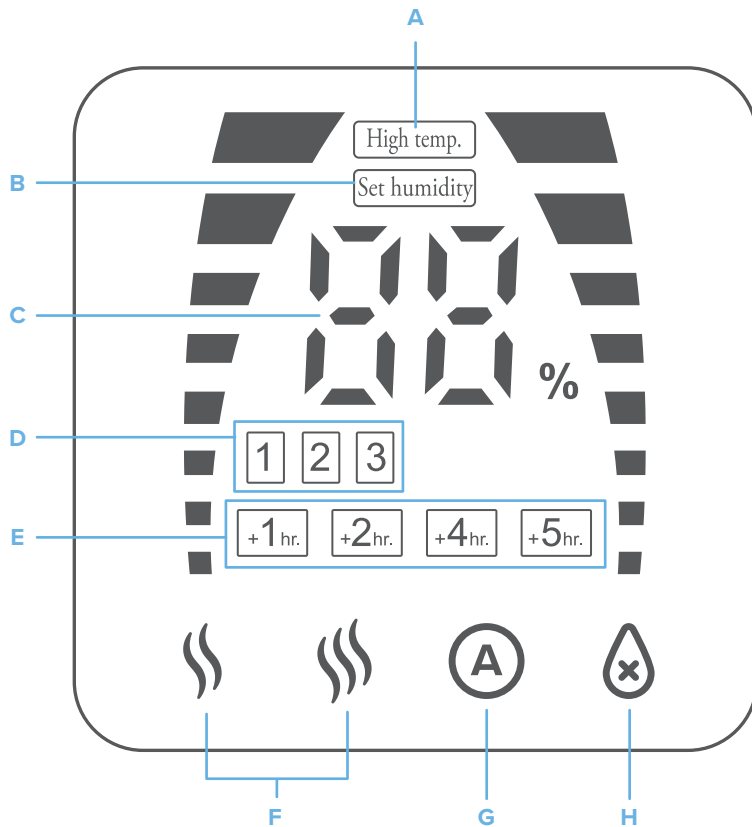

BUTTON CONTROLS



Power Button

- Tap to turn your humidifier on or off.



Mist Level Button

- Tap repeatedly to change the mist level. There are 3 mist level settings.

Note:

- *When you first turn on the humidifier, the default mist level is 2.*



Warm Mist Button

- Tap repeatedly to change or turn on/off the warm mist setting.

Note:

- *Be careful when using the warm mist function, as the mist may be hot.*
- *The warm mist function can be used while Auto Mode is on.*



Humidity Level Button



- Tap repeatedly to change the Relative Humidity (RH) percentage between 40% and 80%. The humidity level on the display will flash 5 times to confirm your selection. To exit the humidity function, tap and hold  for 3 seconds.

Note:

- *Once the humidity percentage of the environment reaches the set RH percentage, it will automatically stop misting. It will start misting again when the humidity drops to 5% below the set level.*
- *After setting the RH percentage, the display will alternate between showing the set RH percentage and the current humidity level.*



Timer Button

- Tap  repeatedly to choose a time.
- When you stop tapping, the display will flash 3 times and the timer will start.
- To exit the timer function, tap  repeatedly or tap and hold until it shows "-- --".
- The humidifier will automatically power off once the timer is finished.



Auto Mode Button

- Tap to start Auto Mode. The humidifier will produce mist as needed to maintain the relative humidity (RH) at a comfortable level.

Relative Humidity	Mist Level
< 60% RH	3
60%–63% RH	2
64%–67% RH	1
> 68% RH	Humidifier automatically shuts off

Note:

- *Changing the mist level while in Auto Mode will cancel the Auto Mode function.*
- *The timer can be set while the humidifier is in Auto Mode.*

GETTING STARTED

1. Remove the nozzle cap from the top of the water tank.
[Figure 1.1]
2. Lift the handle, then pull up on the handle to remove the water tank from the base. [Figure 1.1]
3. Flip the tank over and twist the water tank cap counterclockwise to remove it. [Figure 1.2]
4. Fill the tank with cold or room temperature water. The maximum capacity is 1.5 gallons (5.6 L).

Note:

- Fill the water tank with distilled water, at least half full.
- **Do not** fill the water tank with hot water. Only use cold or room temperature water.
- **Do not** add water through the nozzle, the mist tube, or the inner chamber.
- **Do not** add essential oils through the nozzle, the inner chamber, or into the water tank.

5. Replace the water tank cap. Twist the cap clockwise to secure it tightly to the water tank.
6. Carefully place the water tank back onto the base, aligning the water tank cap with the inner chamber.

Note:

- Wipe off any excess water on the top and bottom of the base before replacing the water tank.

7. Place the nozzle cap back on the top of the water tank.

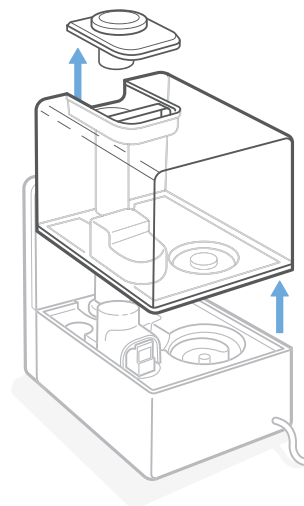

Figure 1.1

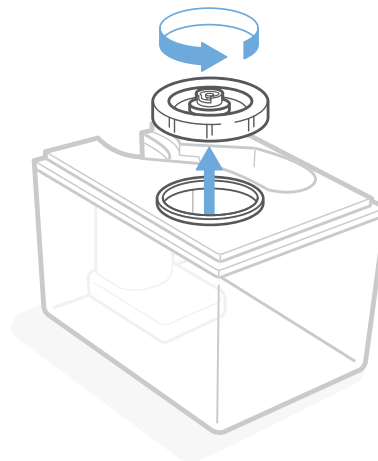

Figure 1.2



OPERATION

General Operation

1. Place the humidifier on level, elevated surfaces, such as tables or nightstands. Make sure the room is well-ventilated.

Note:

- Position the humidifier at least 12 inches (30 cm) away from walls to prevent them from getting wet. [Figure 2.1]
- **Do not** place the humidifier directly on floors, carpets, or rugs.
- Turn the humidifier's nozzle away from any furniture to prevent your furniture from getting wet.

2. Plug in the humidifier. The humidifier will chime.
3. Tap  once to turn on the humidifier. The humidifier will start misting. If there is no water in the tank,  will light up. Unplug the humidifier and refill the water tank. (See **Getting Started**, page 9).

Note:



- **Do not** attempt to inhale the mist directly from the nozzle.

4. **(Optional)** Press the mist level controls to change the mist level.
5. Press  to turn off the humidifier.



Note:

- If the relative humidity in your room exceeds 68%, use the low mist setting or turn off the humidifier.
- When you first turn on the humidifier, the default mist level is 2.
- There are 2 nozzles on the nozzle cap that can rotate 360° to diffuse mist in any direction.

Turning Off the Display

While the humidifier is operating, the display will automatically dim itself after 30 seconds. If you want to turn off the display, press and hold  for 3 seconds. To turn the display back on, press any button, except .

Automatic Shut Off

The humidifier will automatically turn off and  will appear when all of the water in the tank has been diffused. The display will continue showing  until more water is added to the water tank.

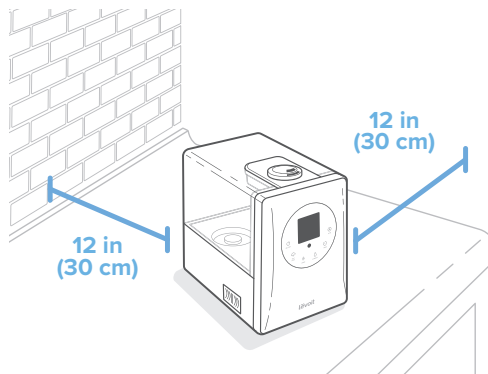

Figure 2.1

USING THE AROMA BOX

Your humidifier can be used as an aroma diffuser to provide added comfort in your home.

1. Turn off and unplug the humidifier.
2. Locate the aroma box at the back of the base.
3. Pull out the aroma box. [Figure 3.1]
4. Put 2-3 drops of essential oil on the aroma pad. [Figure 3.2]
5. Replace the aroma box. Fill the water tank with water and place it back on the base (see **Getting Started**, page 9). [Figure 3.3]
6. Plug in and turn on the humidifier.

Note:

- You can also add medicated vaporizing steam liquid to the aroma pad.
- The aroma pad can be cleaned and reused after diffusing essential oils (see **Cleaning the Aroma Pad**, page 14).

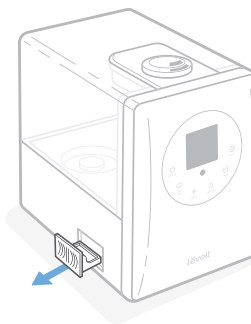

Figure 3.1

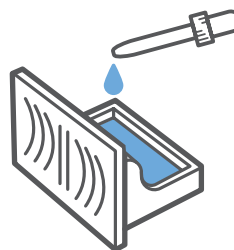

Figure 3.2

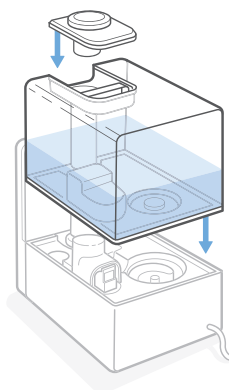

Figure 3.3

PREVENTING WATER LEAKS

If not placed properly, the water tank on your humidifier may leak.

- Make sure the silicone ring in the water tank cap is secured at all times. [\[Figure 4.1\]](#)
- Twist and secure the cap tightly onto the water tank. [\[Figure 4.2\]](#)

Note: A small gap between the cap and the tank is normal.

- Before moving the humidifier, remove the tank from the base and empty any excess water from the inner chamber.
- Wipe off any excess water on the top and bottom of the base.
- **Do not** shake the humidifier or place it on an inclined surface. Make sure to place the humidifier on a flat, level surface. [\[Figure 4.3\]](#)

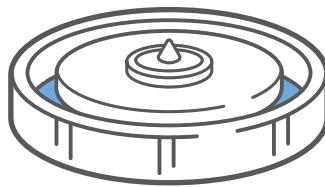

Figure 4.1

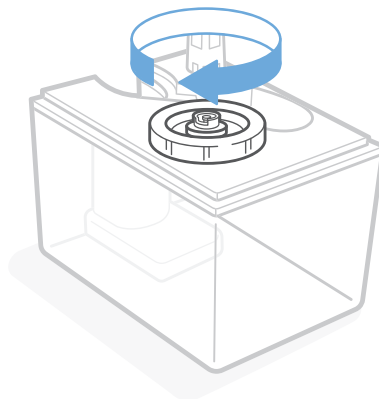

Figure 4.2

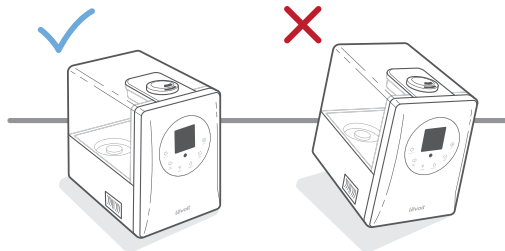

Figure 4.3

KEEPING THINGS CLEAN

CAUTION:

- **Always** make sure the humidifier is unplugged when cleaning.
- The water in the inner chamber near the transducer may still be warm after turning off the humidifier. Allow the humidifier to cool before cleaning. Use caution when pouring out the water.
- **Do not** use liquid detergents.
- Use distilled water instead of tap water to prevent hard water buildup in your humidifier.
- **Do not** submerge base in water.
- Clean your humidifier at least once a month.

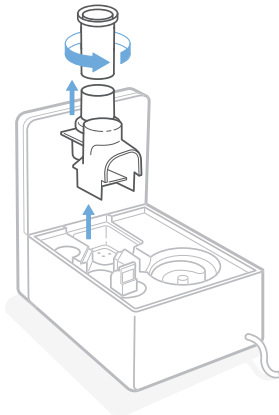

Figure 5.1

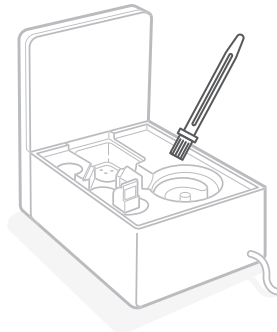

Figure 5.2

General Cleaning

1. Unplug the humidifier.
 2. Remove the nozzle cap from the water tank. Rinse the nozzle and the cover under clean, running water. Set it aside to air dry.
 3. Remove the water tank from the base and pour out any excess water from the inner chamber. Fill the tank with 2 cups of distilled white vinegar and 2 cups of water. Replace the cap and gently shake to coat all sides of the water tank.
 4. Remove the mist channel and mist tube. Detach the mist tube from the mist channel by twisting the tube counterclockwise. [Figure 5.1] Rinse both parts in clean water and dry thoroughly.
 5. Remove the absorption pad inside the heating element and rinse under clean water. Dry the pad with a clean, dry cloth.
 6. Add 1 cup of distilled white vinegar to the inner chamber.
 7. Allow the vinegar to soak inside both the water tank and inner chamber for 30 minutes.
 8. Use the included cleaning brush to remove any scale buildup inside the water tank or in the inner chamber. [Figure 5.2]
 9. Pour out the vinegar from the water tank and the inner chamber and thoroughly rinse with warm water.
- Note:** **Do not** submerge the base in water.
10. Dry all parts with a clean, dry cloth. Make sure all parts of the humidifier are completely dry before reassembling or storing.

Cleaning the Aroma Pad

1. Pull out the aroma box.
2. Remove the aroma pad from the aroma box.
3. Rinse the pad under warm, running water.
4. Dry with a clean cloth and place it back into the aroma box.

NOTE:

- **Do not** pour liquid cleaners or detergents into the aroma pad and box.

Replacing the Remote Control Battery

1. Remove the battery compartment by pinching the tab in and pulling the compartment out. [Figures 6.1–6.2]
2. Remove the old battery.
3. Replace with a new 3V CR2025 battery.

NOTE: Make sure that the polarities match.

4. Replace the battery compartment.

NOTE: The remote control will not work if held more than 16 ft (4.8 m) away from the humidifier.

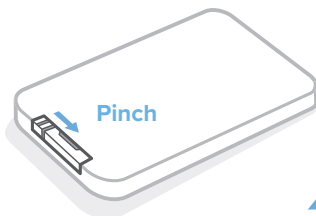

Figure 6.1

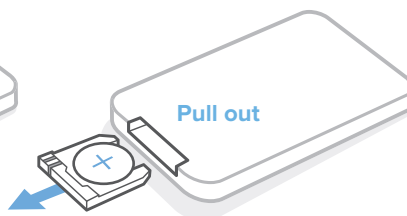

Figure 6.2

Disinfecting the Humidifier

Disinfect the water tank before or after storing the humidifier for long periods of time. You should also disinfect if there is any mold buildup inside the water tank or inner chamber.

1. Clean the water tank as instructed in **General Cleaning** (page 13).
2. Fill the water tank with 1 teaspoon of bleach and 1 gallon of clean water. Reseal the water tank, then gently shake the water tank to ensure all of the sides are coated with the mixture.
3. Put ¼ teaspoon of bleach and 1 cup of clean water into the base.
4. Allow the solutions in both parts to sit for 30 minutes.
5. Pour out the mixtures from both the water tank and base. Rinse both parts thoroughly under clean, running water.
6. Allow the water tank and base to completely air dry before reassembling the humidifier.

Note:

- **Always** wear gloves to protect your hands while using bleach.
- A 3% hydrogen peroxide solution may also be used to disinfect the humidifier.
- **Do not** use the humidifier immediately after disinfecting. This may be a health hazard.

TROUBLESHOOTING

Problem	Possible Causes	Solution
No mist coming out of vent.	Humidifier is not plugged in.	Plug the humidifier into a powered electrical outlet.
	Humidifier is not turned on.	Press  to turn on the humidifier.
	No water in tank.	Add at least 2 cups of clean water into the water tank.
	Water level is low.	Add at least 2 cups of clean water into the water tank.
Humidifier makes a loud or unusual noise.	Water tank does not fit properly.	Turn off and unplug the humidifier, then align the water tank cap with its matching opening in the inner chamber.
	Water level is low.	Add at least 2 cups of clean water into the water tank.
	Humidifier is not level.	Place humidifier on a flat, level surface.
	Humidifier is malfunctioning.	Turn off, unplug, and stop using the humidifier. Contact Customer Support (page 17).
Humidifier produces an unusual smell.	Humidifier is new.	Remove the water cap, and place the water tank in a cool, dry place for 12 hours.
	Residual smell from diffusing essential oil on the aroma pad.	Remove the aroma pad, rinse it under clean water, and allow it to dry.
	Water is dirty, or water has been in the tank for a long time.	Clean the humidifier (see General Cleaning , page 13).
Mist is coming out from the base.	Water tank is not positioned correctly.	Turn off and unplug the humidifier, then align the water tank cap with its matching opening in the inner chamber.
High temperature warning is on the display.	The heating element is running without any water in the humidifier.	Unplug the humidifier, add water to the water tank, and turn on the humidifier. If the high temperature warning is still on, contact Customer Support (page 17).

TROUBLESHOOTING (cont.)

Problem	Possible Causes	Solution
Relative Humidity (RH) level displayed is incorrect.	Room is larger than the effective range of the humidifier.	Move the humidifier to a room that is within the effective range of 430–753 ft ² (40–70 m ²).
	Relative humidity in the room is too high.	If the relative humidity in the room is over 68%, set the humidifier to the lowest mist setting or turn off the humidifier.
	Moisture has built up inside of the humidity sensor.	Turn off the humidifier and allow the humidity sensor to air dry before using again.
	The nozzle is facing the direction of the humidity sensor.	Turn the nozzle so that it is facing away from the humidity sensor.
	Humidity sensor is broken or defective.	Contact Customer Support (page 17).
White dust appears around the humidifier.	Water being used has a high mineral content.	Use distilled water to fill the humidifier.
	Humidifier was not properly cleaned after last use.	Clean the humidifier (see General Cleaning , page 13). Remember to clean the water tank at least once a month.
Puddle of water forms below the base.	Mist setting is too high.	Switch the humidifier to a lower mist setting.
	Room is not well-ventilated.	Open a window to ensure proper airflow for your humidifier, or move the humidifier to a more well-ventilated room.

If your problem is not listed, please contact **Customer Support** (page 17).

WARRANTY INFORMATION

Product Name	Hybrid Ultrasonic Humidifier
Model Number	LV600HH
Default Warranty Period	1 year
<i>For your own reference, we strongly recommend that you record your order number and date of purchase.</i>	
Date of Purchase	
Order Number	

TERMS & POLICY

Levoit warrants all products to be of the highest quality in material, craftsmanship, and service, effective from the date of purchase to the end of the warranty period.

Levoit will replace any product found to be defective due to manufacturer flaws based on eligibility. Refunds are available within the first 30 days of purchase. Refunds are only available to the original purchaser of the product. This warranty extends only to personal use and does not extend to any product that has been used for commercial, rental, or any other use in which the product is not intended for. There are no warranties other than the warranties expressly set forth with each product.

This warranty is non-transferrable. Levoit is not responsible in any way for any damages, losses, or inconveniences caused by equipment failure by user negligence, abuse, or use noncompliant with the user manual or any additional safety, use, or warnings included in the product packaging and manual.

This warranty does not apply to the following:

- Damage due to abuse, accident, alteration, misuse, tampering, or vandalism.
- Improper or inadequate maintenance.
- Damage in return transit.
- Unsupervised use by children under 18 years of age.

Levoit and its subsidiaries assume no liability for damage caused by the use of the product other than for its intended use or as instructed in the user manual. Some states do not allow this exclusion or limitation of incidental or consequential losses so the foregoing disclaimer may not apply to you. This warranty gives you specific legal rights and you may also have other rights which may vary from state to state.

ALL EXPRESSED AND IMPLIED WARRANTIES, INCLUDING THE WARRANTY OF MERCHANTABILITY, ARE LIMITED TO THE PERIOD OF THE LIMITED WARRANTY.

Additional 1-Year Warranty

You can extend your 1-year warranty by an additional year. Log onto www.levoit.com/warranty and enter your order number (for example, from Amazon or Houzz) to register your new product for the extended warranty.

If you are unable to provide the order number for your product, please type a short note in the order number field along with the date you received your product.

Defective Products & Returns

If your product proves defective within the specified warranty period, please contact Customer Support via support@levoit.com with your order number. **DO NOT** dispose of your product before contacting us. Once Customer Support has approved your request, please return the unit with a copy of the invoice or your order number.

CUSTOMER SUPPORT

If you encounter any issues or have any questions regarding your new product, feel free to contact our helpful Customer Support Team. Your satisfaction is our goal!

Arovast Corporation

1202 N. Miller St., Suite A
Anaheim, CA 92806

Email: support@levoit.com

Toll-Free: (888) 726-8520

Support Hours

Mon–Fri, 9:00 am–5:00 pm PST/PDT

**Please have your order invoice and order number ready before contacting Customer Support.*

Connect with us @LevoitLifestyle



lěvoit

Levoit.com

V6.0