



## **TradeCharge30** **RCBT30**

30amp, 12/24V Bench Charger  
150amp Engine Start

## **TradeCharge35** **RCBT35**

35amp, 12/24V Bench Charger  
180amp Engine Start

## **TradeCharge40T** **RCBT40T**

40amp, 12/24V Trolley Charger  
280amp Engine Start

## **TradeCharge55T** **RCBT55T**

55amp, 12/24V Trolley Charger  
420amp Engine Start

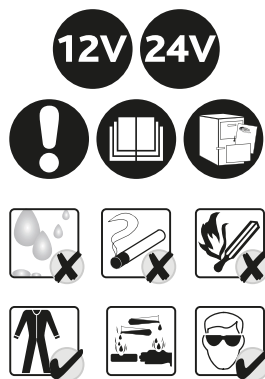

# **User Manual**

[www.ringautomotive.com](http://www.ringautomotive.com)

RETAIN THESE INSTRUCTIONS FOR FUTURE REFERENCE







## 1.2 RCBT35

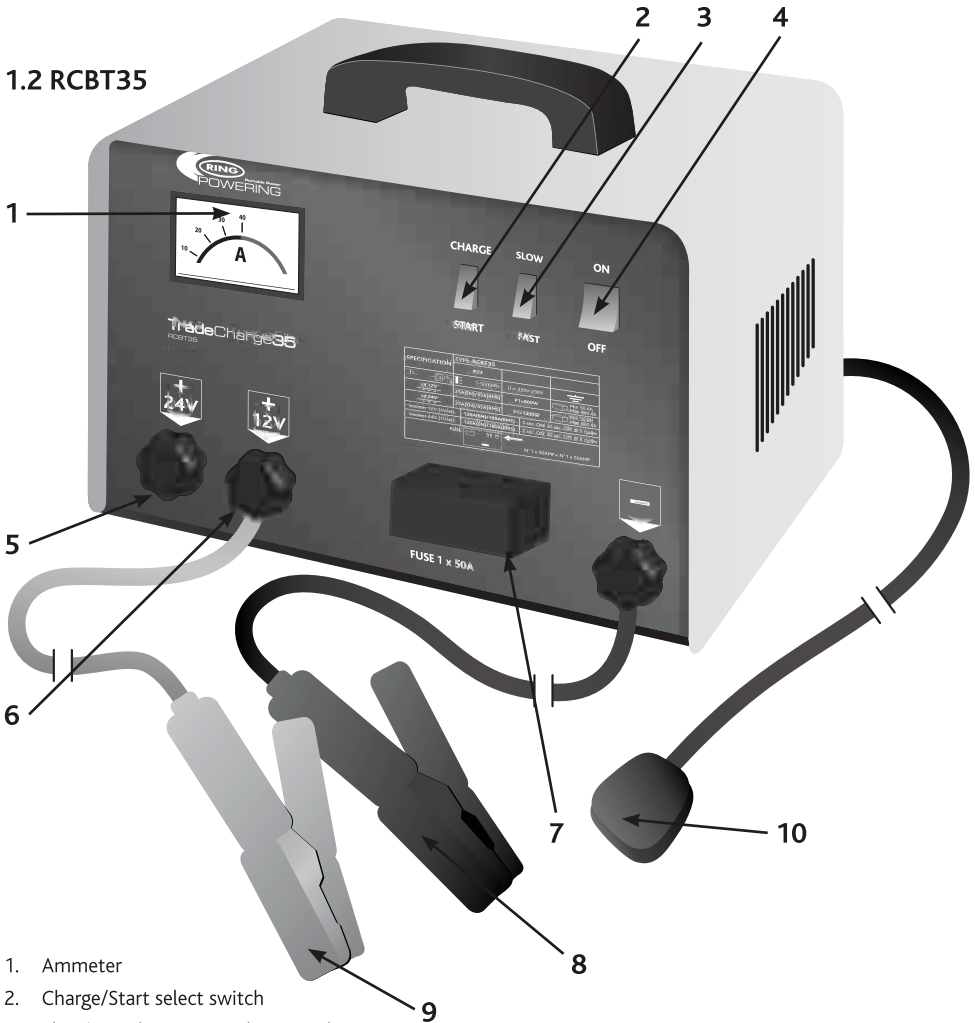

1. Ammeter
2. Charge/Start select switch
3. Slow/Fast charge rate select switch
4. AC Supply On/Off Switch
5. 24V Positive Lead Connector
6. 12V Positive Lead Connector
7. Protective Fuse (1x 50amp)
8. Negative(-) battery clip
9. Positive(+) battery clip
10. AC Mains supply plug

## 1. PRODUCT OVERVIEW

### 1.3 RCBT40T

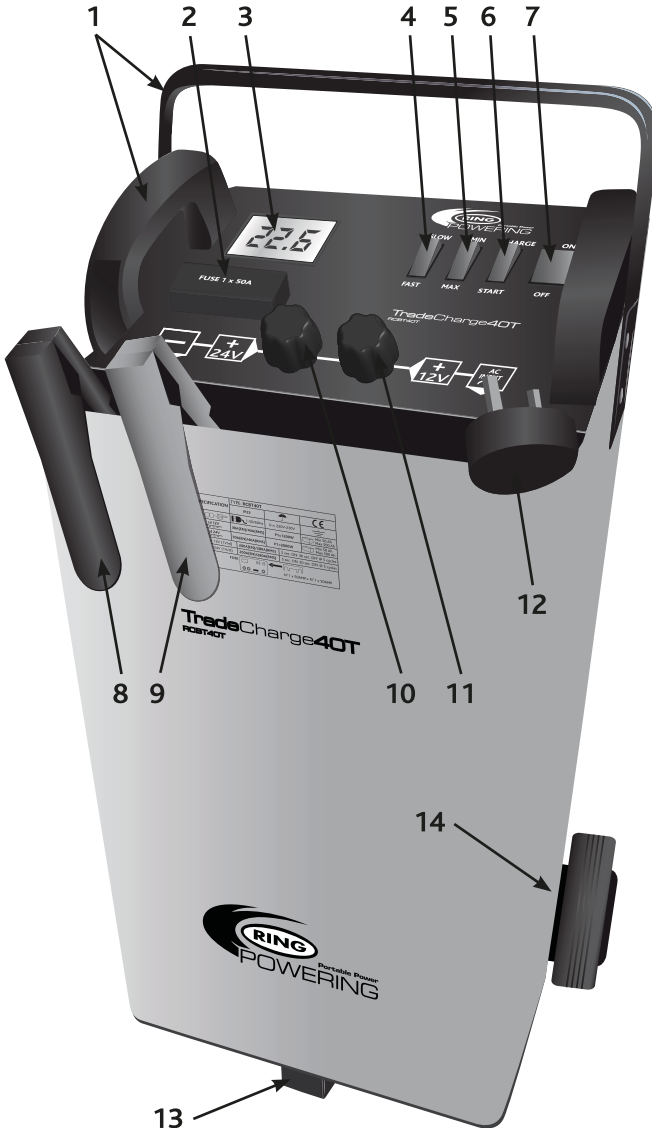

1. Transport handles
2. Protective Fuse (1x 50amp)
3. Digital Ammeter
4. Slow/Fast charge rate select switch
5. Min/Max charge rate select switch
6. Charge/Start select switch
7. Illuminated AC Supply On/Off Switch
8. Negative(-) battery clip
9. Positive(+) battery clip
10. 24V Positive Lead Connector
11. 12V Positive Lead Connector
12. AC Mains supply plug
13. Foot
14. Trolley Wheels

## 1.4 RCBT55T



1. Transport handles
2. AC power Indicator
3. Charge rate selector dial
4. Digital Ammeter
5. Protective Fuse (2x 50amp)
6. AC Mains supply plug
7. 60 minute timer dial
8. 24V Positive Lead Connector
9. 12V Positive Lead Connector
10. Positive(+) battery clip
11. Negative(-) battery clip
12. 2x Feet
13. Trolley Wheels

## 2. ASSEMBLY

### 2.1 RCBT40T & RCBT55T

#### 2.1.1 WHEELS

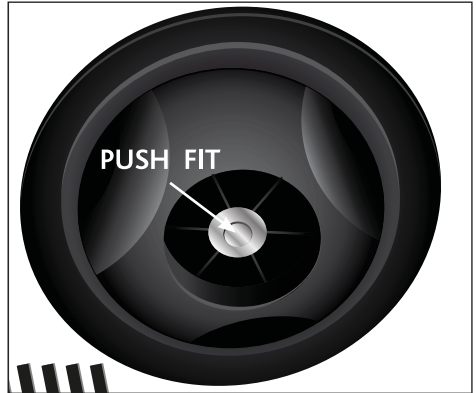
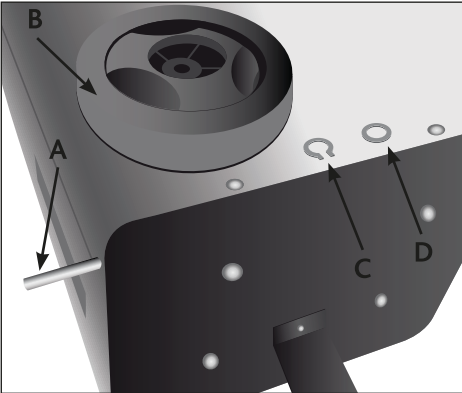

1. Pass axle 'A' through the main charger casing
2. Fit wheels 'B' into position on axle and fix in place with washer 'D' and circlip 'C'.  
Note:- circlips are best fitted using long nosed pliers.

#### 2.1.2 FOOT

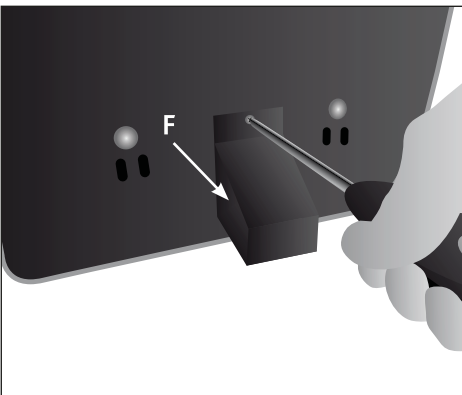

1. Position foot 'F' on underside front and fix in position with 3x screws and washers (supplied)  
Note:- RCBT55T model is provided with 2x feet

#### 2.1.3 TRANSPORT HANDLE

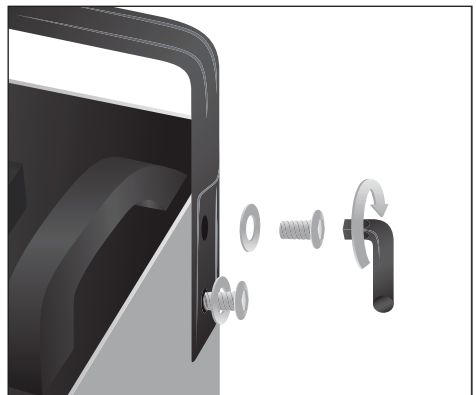

1. Fix handle in place using 4x allen bolts and washers.  
Tighten firmly using allen key provided.



## 3. OPERATING INSTRUCTIONS

### 3.1 RCBT30

#### 3.1.1 BATTERY CHARGING

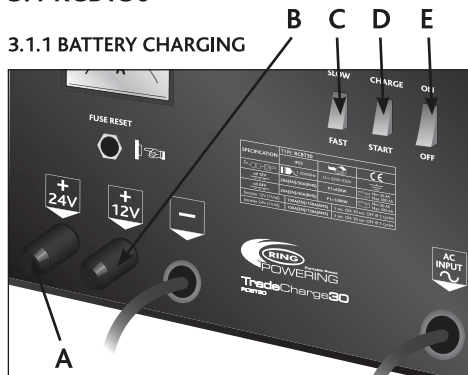

1. Ensure the AC mains plug is not connected to the AC supply.
2. Connect Red(+) battery lead to 24V (position 'A') or 12V (position 'B') appropriate for the battery to be re-charged.
3. Connect the Red(+) positive battery clip to the Red(+) battery positive terminal.
4. Connect the Black(-) negative battery clip to the vehicle chassis, always away from the battery and fuel line.
5. Set the Charge/Start select switch 'D' to the CHARGE position.
6. Set the Slow/Fast charge rate select switch to SLOW or FAST.
7. Connect plug to AC mains power and turn on charger with switch 'E'.
8. Observe the charge rate on the ammeter after about 1 minute, if it exceeds 10% of the battery capacity then reduce the charge rate to the next lowest level e.g. for a 100Ah battery, charge rate should be 10amps or less.
9. The charge rate will slowly reduce until it should be close to zero, at which point the charger should be switched off to protect the battery against overcharging.
10. Switch off and disconnect the AC mains supply. Disconnect the Red(+) positive battery clip. Disconnect the Black(-) negative battery clip.

### WARNING!

BEFORE USING THE 'ENGINE START' FUNCTION A 5 MINUTE 'FAST CHARGE' IS RECOMMENDED TO AVOID TRIPPING OF THE MAINS SUPPLY FUSES

#### 3.1.2 ENGINE START

To ensure safe use of the unit please read these instructions fully before operating the unit.

Please note that the Engine start mode is designed to provide a high current for a very short time; if not used correctly these high currents could result in damage to the vehicle engine management system - please follow these instructions carefully.

We recommend that the Engine start function is operated with 2 persons present; one to switch the unit on and one to crank the engine.

1. Ensure that the unit is isolated from the mains before attaching the clamps to the vehicle.
2. Select the charging voltage by connecting the red (+) lead to the 12V or 24V terminal.
3. Connect the red (+) battery clip to the positive (+) battery terminal.
4. Connect the black (-) battery clip to the vehicle chassis away from the battery and fuel line.
5. Set the charge/start switch to the "start" position (RCBT35/35/40T) or set the dial to the "start" position.
6. Connect the plug to the AC mains supply.
7. Set the power switch to "on" position (indicator only on RCBT55T unit) and immediately crank the engine for a maximum of 5s.
8. Once 5s has elapsed immediately switch off the power to the RCBT unit.
9. Once the vehicle is running remove the battery clips.
10. If the vehicle fails to start always perform another fast charge for 5 minutes before attempting another engine start.

#### 3.1.3 OVERLOAD PROTECTION

##### OUTPUT FUSE

The unit front panel is fitted with a protective thermal fuse, which may operate if the unit is overloaded, shorted or connected with reverse polarity.

1. Ensure AC mains plug is not connected to the supply.
2. Wait a few minutes then push the trip switch to reset it.

##### TRANSFORMER THERMAL TRIP

The unit is fitted with a thermal cut-out device, which will activate if the unit overheats. Should this happen the lamp inside the On/Off switch will go out. Once cooled the unit will automatically reset and resume normal operation.



## 3.2 RCBT35

### 3.2.1 BATTERY CHARGING

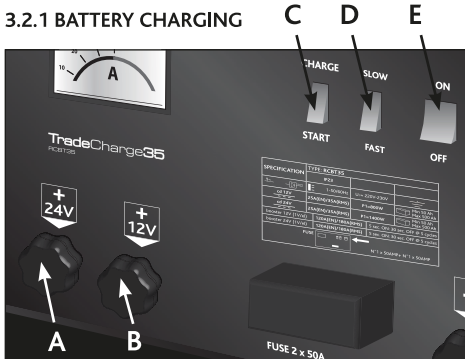

1. Ensure the AC mains plug is not connected to the AC supply.
2. Connect Red(+) battery lead to 24V (position 'A') or 12V (position 'B') appropriate for the battery to be re-charged.
3. Connect the Red(+) positive battery clip to the Red(+) battery positive terminal.
4. Connect the Black(-) negative battery clip to the vehicle chassis, always away from the battery and fuel line.
5. Set the Charge/Start select switch 'C' to the CHARGE position.
6. Set the Slow/Fast charge rate select switch to SLOW or FAST.
7. Connect plug to AC mains power and turn on charger with switch 'E'.
8. Observe the charge rate on the ammeter after about 1 minute, if it exceeds 10% of the battery capacity then reduce the charge rate to the next lowest level e.g. for a 100Ah battery, charge rate should be 10amps or less.
9. The charge rate will slowly reduce until it should be close to zero, at which point the charger should be switched off to protect the battery against overcharging.
10. Switch off and disconnect the AC mains supply. Disconnect the Red(+) positive battery clip. Disconnect the Black(-) negative battery clip.

### WARNING!

BEFORE USING THE 'ENGINE START' FUNCTION A 5 MINUTE 'FAST CHARGE' IS RECOMMENDED TO AVOID TRIPPING OF THE MAINS SUPPLY FUSES

### 3.2.2 ENGINE START

To ensure safe use of the unit please read these instructions fully before operating the unit.

Please note that the Engine start mode is designed to provide a high current for a very short time; if not used correctly these high currents could result in damage to the vehicle engine management system - please follow these instructions carefully.

We recommend that the Engine start function is operated with 2 persons present; one to switch the unit on and one to crank the engine.

1. Ensure that the unit is isolated from the mains before attaching the clamps to the vehicle.
2. Select the charging voltage by connecting the red (+) lead to the 12V or 24V terminal.
3. Connect the red (+) battery clip to the positive (+) battery terminal.
4. Connect the black (-) battery clip to the vehicle chassis away from the battery and fuel line.
5. Set the charge/start switch to the "start" position (RCBT35/35/40T) or set the dial to the "start" position.
6. Connect the plug to the AC mains supply.
7. Set the power switch to "on" position (indicator only on RCBT55T unit) and immediately crank the engine for a maximum of 5s.
8. Once 5s has elapsed immediately switch off the power to the RCBT unit.
9. Once the vehicle is running remove the battery clips.
10. If the vehicle fails to start always perform another fast charge for 5 minutes before attempting another engine start.

### 3.2.3 OVERLOAD PROTECTION

#### OUTPUT FUSE

The unit front panel is fitted with a protective fuse, which may blow if the unit is overloaded, shorted or connected with reverse polarity.

1. Ensure AC mains plug is not connected to the supply.
2. Remove cover labelled 'FUSE'.
3. Loosen 2 x 10mm nuts holding fuse(s) in place and replace with same value(s).
4. Re-tighten bolts and replace cover.

#### TRANSFORMER THERMAL TRIP

The unit is fitted with a thermal cut-out device, which will activate if the unit overheats. Should this happen the lamp inside the On/Off switch will go out. Once cooled the unit will automatically reset and resume normal operation.



## 3.3 RCBT40T

### 3.3.1 BATTERY CHARGING

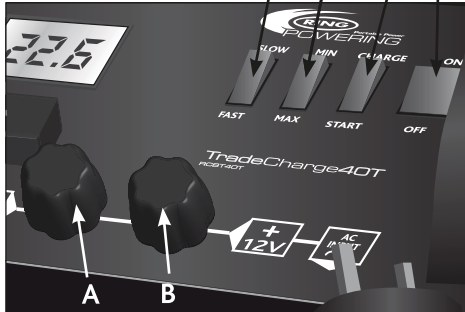

1. Ensure the AC mains plug is not connected to the AC supply.
2. Connect Red(+) battery lead to 24V (position 'A') or 12V (position 'B') appropriate for the battery to be re-charged.
3. Connect the Red(+) positive battery clip to the Red(+) battery positive terminal.
4. Connect the Black(-) negative battery clip to the vehicle chassis, always away from the battery and fuel line.
5. Set the Charge/Start select switch 'E' to the CHARGE position.
6. Set the charge rate required using switches 'C' and 'D' as follows:-  
 SLOW+MIN = Low charge rate  
 SLOW+MAX = Medium/Low charge rate  
 FAST+MIN = Medium/High charge rate  
 FAST+MAX = High charge rate
7. Connect plug to AC mains power and turn on charger with switch 'F'.
8. Observe the charge rate on the ammeter after about 1 minute, if it exceeds 10% of the battery capacity then reduce the charge rate to the next lowest level e.g. for a 100Ah battery, charge rate should be 10amps or less.
9. The charge rate will slowly reduce until it should be close to zero, at which point the charger should be switched off to protect the battery against overcharging.
10. Switch off and disconnect the AC mains supply. Disconnect the Red(+) positive battery clip. Disconnect the Black(-) negative battery clip.

### WARNING!

**BEFORE USING THE 'ENGINE START' FUNCTION A 5 MINUTE 'FAST CHARGE' IS RECOMMENDED TO AVOID TRIPPING OF THE MAINS SUPPLY FUSES**

### 3.3.2 ENGINE START

To ensure safe use of the unit please read these instructions fully before operating the unit.

Please note that the Engine start mode is designed to provide a high current for a very short time; if not used correctly these high currents could result in damage to the vehicle engine management system - please follow these instructions carefully.

We recommend that the Engine start function is operated with 2 persons present; one to switch the unit on and one to crank the engine.

1. Ensure that the unit is isolated from the mains before attaching the clamps to the vehicle.
2. Select the charging voltage by connecting the red (+) lead to the 12V or 24V terminal.
3. Connect the red (+) battery clip to the positive (+) battery terminal.
4. Connect the black (-) battery clip to the vehicle chassis away from the battery and fuel line.
5. Set the charge/start switch to the "start" position (RCBT35/35/40T) or set the dial to the "start" position.
6. Connect the plug to the AC mains supply.
7. Set the power switch to "on" position (indicator only on RCBT55T unit) and immediately crank the engine for a maximum of 5s.
8. Once 5s has elapsed immediately switch off the power to the RCBT unit.
9. Once the vehicle is running remove the battery clips.
10. If the vehicle fails to start always perform another fast charge for 5 minutes before attempting another engine start.

### 3.3.3 OVERLOAD PROTECTION

#### OUTPUT FUSE

The unit front panel is fitted with a protective fuse, which may blow if the unit is overloaded, shorted or connected with reverse polarity.

1. Ensure AC mains plug is not connected to the supply.
2. Remove cover labelled 'FUSE'.
3. Loosen 2 x 10mm nuts holding fuse(s) in place and replace with same value(s).
4. Re-tighten bolts and replace cover.

#### TRANSFORMER THERMAL TRIP

The unit is fitted with a thermal cut-out device, which will activate if the unit overheats. Should this happen the lamp inside the On/Off switch will go out. Once cooled the unit will automatically reset and resume normal operation.

#### MAINS SUPPLY FUSE

The unit is fitted with a 13A fused plug. This may blow under certain conditions such as cranking a deeply discharged, high capacity battery e.g. larger than 150Ah. If this happens regularly it may be advisable to replace the mains input plug with a 16amp type (see section 4 - 'Mains Input Plug').



## 3.4 RCBT55T

### 3.4.1 BATTERY CHARGING A B C D E



1. Connect Red(+) battery lead to 12V (position 'D') or 24V (position 'E') appropriate for the battery to be re-charged.
2. Connect the Red(+) positive battery clip to the Red(+) battery positive terminal.
3. Ensure the AC mains plug is not connected to the AC supply.
4. Connect the Black(-) negative battery clip to the vehicle chassis, always away from the battery and fuel line.
5. Set the charge rate required using charge rate selector dial 'C' as follows:-  
 0 = Off  
 1 = Slow/Low charge setting  
 2 = Slow/Medium charge setting  
 3 = Slow/High charge setting  
 4 = Fast/Low charge setting (via timer)  
 5 = Fast/Medium charge setting (via timer)  
 6 = Fast/High charge setting (via timer)
6. For 'fast charge' settings 4-6, the charging time is limited by a timer, to protect against overcharging. Set the required charging time using dial 'B' (60 minutes maximum).
7. Connect plug to AC mains power, indicator 'A' should illuminate.
8. Observe the charge rate on the ammeter after about 1 minute, if it exceeds 10% of the battery capacity then reduce the charge rate to the next lowest level e.g. for a 100Ah battery, charge rate should be 10amps or less.
9. The charge rate will slowly reduce until it should be close to zero, at which point the charger should be switched off to protect the battery against overcharging.
10. Switch off and disconnect the AC mains supply. Disconnect the Red(+) positive battery clip. Disconnect the Black(-) negative battery clip.

### WARNING!

BEFORE USING THE 'ENGINE START' FUNCTION A 5 MINUTE 'FAST CHARGE' IS RECOMMENDED TO AVOID TRIPPING OF THE MAINS SUPPLY FUSES

### 3.4.2 ENGINE START

To ensure safe use of the unit please read these instructions fully before operating the unit.

Please note that the Engine start mode is designed to provide a high current for a very short time; if not used correctly these high currents could result in damage to the vehicle engine management system - please follow these instructions carefully.

We recommend that the Engine start function is operated with 2 persons present; one to switch the unit on and one to crank the engine.

1. Ensure that the unit is isolated from the mains before attaching the clamps to the vehicle.
2. Select the charging voltage by connecting the red (+) lead to the 12V or 24V terminal.
3. Connect the red (+) battery clip to the positive (+) battery terminal.
4. Connect the black (-) battery clip to the vehicle chassis away from the battery and fuel line.
5. Set the charge/start switch to the "start" position (RCBT35/35/40T) or set the dial to the "start" position.
6. Connect the plug to the AC mains supply.
7. Set the power switch to "on" position (indicator only on RCBT55T unit) and immediately crank the engine for a maximum of 5s.
8. Once 5s has elapsed immediately switch off the power to the RCBT unit.
9. Once the vehicle is running remove the battery clips.
10. If the vehicle fails to start always perform another fast charge for 5 minutes before attempting another engine start.

### 3.4.3 OVERLOAD PROTECTION

#### OUTPUT FUSE

The unit front panel is fitted with a protective fuse, which may blow if the unit is overloaded, shorted or connected with reverse polarity.

1. Ensure AC mains plug is not connected to the supply.
2. Remove cover labelled 'FUSE'.
3. Loosen 2 x 10mm nuts holding fuse(s) in place and replace with same value(s).
4. Re-tighten bolts and replace cover.



### 3.4 RCBT55T

#### TRANSFORMER THERMAL TRIP

The unit is fitted with a thermal cut-out device, which will activate if the unit overheats. Should this happen the AC power indicator 'A' will go out. Once cooled the unit will automatically reset and resume normal operation.

#### MAINS SUPPLY FUSE

The unit is fitted with a 13A fused plug. This may blow under certain conditions such as cranking a deeply discharged, high capacity battery e.g. larger than 150Ah. If this happens regularly it may be advisable to replace the mains input plug with a 16amp type (see section 4 – 'Mains Input Plug').

## 4. MAINS INPUT PLUG

### 4.1 UPGRADING TO 16AMP (RCBT40T & RCBT55T ONLY)

#### WARNING!

**THE FOLLOWING WIRING MUST ONLY BE CARRIED OUT BY A QUALIFIED ELECTRICIAN**

Remove the existing 13amp plug and replace it with a 16amp IEC309 type plug wired as follows:-

Connect Green/Yellow earth wire to terminal ⊕  
 Connect Brown live wire to terminal 'L'  
 Connect Blue neutral wire to terminal 'N'

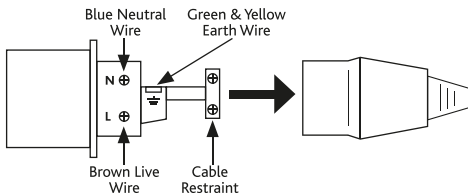

Before connecting the unit, ensure the mains supply is protected by a suitably rated fuse or circuit breaker. To ensure the risk of electric shock is minimised, the supply must also be protected by an earth leakage protection device (RCD or RCCB).

### 4.2 CONVERTING TO 2-PIN

To convert the input plug to the 2-pin European type, first remove 2x screws on the base of the plug, then open cover. The 2-pin plug can then be removed.



## 5. RECYCLING

This product may not be disposed of together with domestic waste in compliance with the (2002/96/EC) Regulation relating to waste electrical and electronic devices (WEEE). This product must be handed in at a designated collection point. Information on collecting points for waste equipment can be obtained from your public waste disposal authority.





## 6. SPECIFICATIONS

Model	RCBT30	RCBT35	RCBT40T	RCBT55T
AC Input Voltage	230V	230V	230V	230V
AC Input Power (12V/24V)	650/1200W	800/1400W	1200/2000W	1400/2600W
Charge current (peak)	42A	50A	55A	80A
Charge current (effective/RMS)	30A	35A	40A	55A
Charge current (arithmetic/EN)	20A	25A	30A	40A
Start current (peak)	180A	240A	400A	600A
Start current (effective/RMS)	150A	180A	280A	420A
Start current (arithmetic/EN)	100A	120A	200A	350A
Cranking ON cycle (sec)	5	5	5	5
Cranking OFF cycle (sec)	30	30	30	30
Cranking Cycles (max)	5	5	5	5
Battery Capacity	30-300Ah	50-400Ah	50-400Ah	50-600Ah
Output fuse	Thermal	1 x 50A	1 x 50A	2 x 50A
Dimension(mm)	214x308x245	220x335x260	553x293x207	640x343x270
Weight(kg)	11	14	21	28

## 7. SPARE PARTS

Part No.	Description	Part No.	Description
RCBTAM1	Analogue Ammeter (30/35 only)	RCBTBC1	Red Battery Clamp with Cable (RCBT30 only)
RCBTAM2	Digital Ammeter (RCBT40T/55T only)	RCBTBC2	Red Battery Clamp with Cable (RCBT35/40T/55T only)
RCBTTH1	Transport Handle (RCBT40T only)	RCBTBC3	Black Battery Clamp with Cable (RCBT30 only)
RCBTTH2	Transport Handle (RCBT55T only)	RCBTBC4	Black Battery Clamp with Cable (RCBT35/40T/55T only)
RCBTSW1	Multi-Position Switch (RCBT30/35/40T only)	RCBTTS1	Small Screw On Terminal Assembly (RCBT30 only)
RCBTSW2	Illuminated On/Off Switch (RCBT30 only)	RCBTTL1	Large Screw On Terminal Assembly (RCBT35/40T/55T only)
RCBTSW3	Illuminated On/Off Switch (RCBT30/40T only)	RCBTMA1	Euro to UK Adaptor (all models)
RCBTSW4	Multi-Position Switch (RCBT55T only)	RCBTAK1	Axle (RCBT40T only)
RCBTTF1	Thermal Fuse (RCBT30 only)	RCBTAK2	Axle (RCBT55T only)
RCBTI1	Timer Assembly (RCBT55T only)	RCBTFK1	Fixing Kit (RCBT40T/55T only)
RCBT50F	50 Amp Fuse (5 pack) (RCBT35/40T/55T)	RCBTWH1	Wheel (RCBT40T/55T only)
RCBTFC1	Fuse Cover (RCBT35/40T/55T only)	RCBTSF1	Stabiliser Foot (RCBT40T/55T only)



Ring Automotive Limited, Gelderd Road, Leeds LS12 6NA England

☎ +44 (0)113 213 2000 📞 +44 (0)113 231 0266

✉ autosales@ringautomotive.com 🌐 Website: www.ringautomotive.com

**OSRAM GmbH**

Nonnendammallee 44

13629 Berlin, Germany

✉ automotive-service@osram.com

**UK  
CA**

