

Smoker House

INSTRUCTION

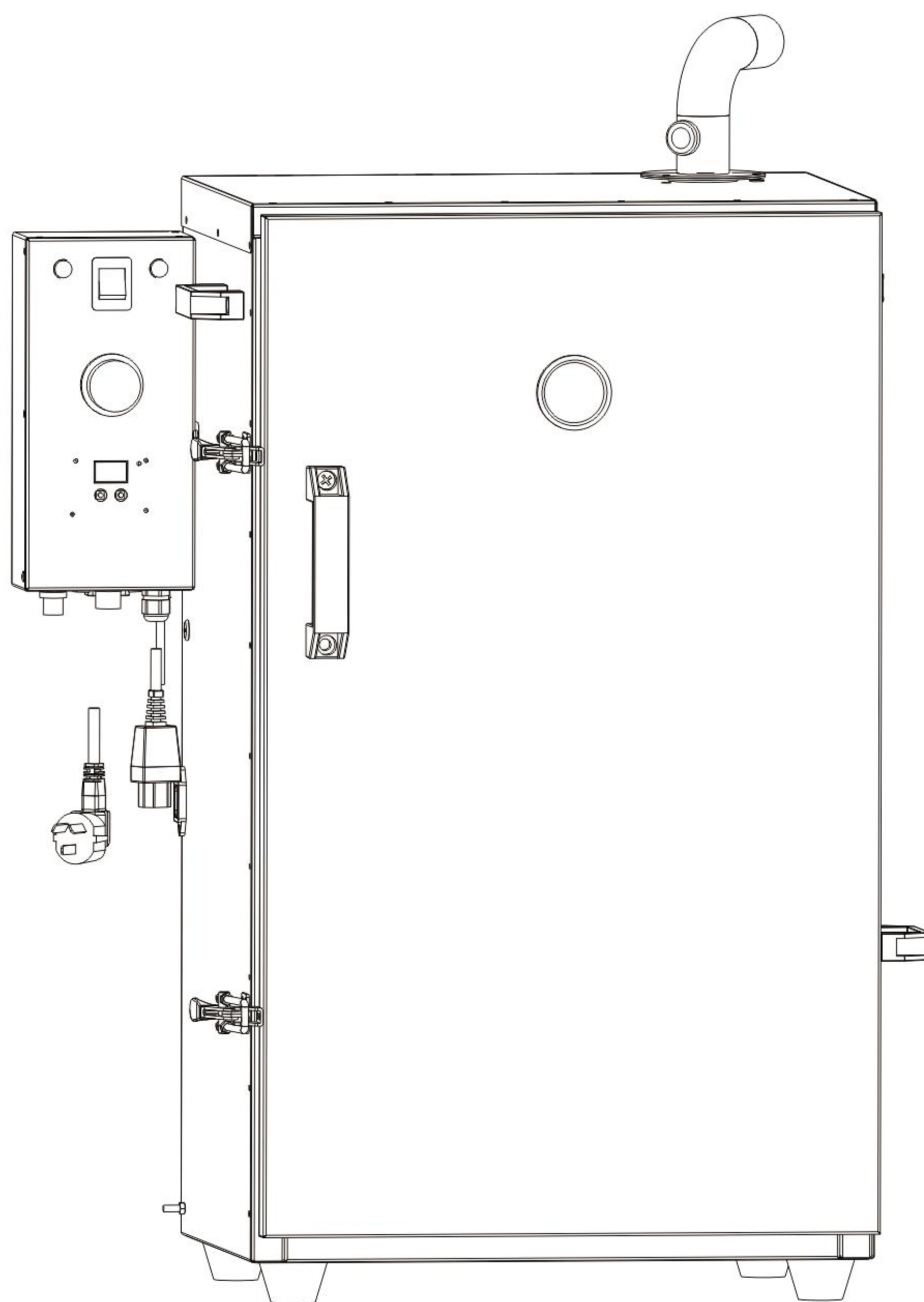

Model :
DSH-20B
DSH-50B

* PLEASE NOTE: READ THIS INSTRUCTION MANUAL BEFORE USING.

Our factory reserve the right of final interpretation for the user manual.

The product appearance is subject to the product that you receive.

The parameters are subject to change without prior notice.

CONTENT

CHAPTER 1 | COMPANY BRIEF INTRODUCTION

CHAPTER 2 | SAFETY SPECIFICATION

CHAPTER 3 | ASSEMBLY AND OPERATION INSTRUCTION

CHAPTER 4 | OPERATION INSTRUCTION AND EXCEPTION HANDLING

CHAPTER 5 | EXPLODED VIEW AND SPARE PARTS LIST

CHAPTER 6 | WIRING DIAGRAM OF CONTROL BOX

WARRANTY CARD

CHAPTER 1 COMPANY BRIEF INTRODUCTION

Thanks for choosing our machines. We are a company who specialized in food processing machines field for many years. The main products are spiral mixers, planetary mixers, meat grinders/mincers, meat slicers, meat mixers, sausage stuffers/fillers, meat tenderizers, and so on. With the strength of good quality and after-sales service, we have won reputation from the customers all around the world.

CHAPTER 2 SAFETY SPECIFICATION:

Warning: 

- 1.To prevent the accident of fire or electric shock, please use the the safety specification.
- 2.It is forbidden to use this machine in the raining, uneven and non-heat-resistant environment.
- 3.It is forbidden to circle the power cord into the round shape (includes the power supply line), otherwise it will heat up or even cause fire.
- 4.It is forbidden to open the machine door under the condition of power-on and use the machine when the door is opened. Please mind the scald.
- 5.It is forbidden to rinse the machine with water in case of the short circuit of electric appliance.
- 6.It is forbidden to use the damaged power cord, the heating tube, etc.
- 7.It is forbidden to use the machine when it is unattended.
- 8.It is forbidden to put the flammable and combustible materials around the machine and block the ventilating hole (the shelf below the right side) of heating tube.
- 9.It is forbidden to let the water enter into the ventilating hole of heating tube, otherwise it will cause the electric shock.

TECHNICAL PARAMETER SUBJECT TO CHANGE WITHOUT NOTICE

10.It is forbidden to insert the power cord into the cabinet body directly when use. Please make sure the cabinet body is combined with the control box and inserted with the power cord when use, otherwise the temperature inside the cabinet body is out of control, which will cause the accident.

Notices:

- 1.Please keep the plastic bag well. Don't let the children play with it in case of suffocation.
- 2.This product is design for the adult. Please don't let the children operate it.
- 3.This product is divided into 2 kinds of working voltage: AC110V or AC220V respectively. Please choose it according to the local voltage.
- 4.Make sure the voltage that you use is consistent with the voltage on name plate; make sure the power supply comes with the leakage protector & the ground wire; make sure the power supply line can carry the power (check the parameters according to the nameplate) of product.
- 5.Check the power cord and the heating tube. It's forbidden to use them if they are damaged. Then please ensure to replace the qualified power cord supplied by the factory.
- 6.Please don't put into the flours, alcohols or other flammable and explosive materials to heat up.
- 7.Please tear off all the protective films before use.
- 8.After use, please make sure to power off the whole machine when it is unattended.
- 9.Please don't disassemble the product randomly.
- 10.Only the spare parts supplied by the seller or the manufacturer can be used in this product. We don't take responsible for any malfunctions caused by the spare parts provided by other manufacturers.
- 11.Once the product causes fire accidentally, please power off and put out the fire under the premise of ensuring human safety.
- 12.Check and clean the flammable and explosive materials around the machine.
- 13.It is advised to use the machine on the non-flammable materials.
- 14.Please ensure to power off and emit the smoke out of the cabinet by opening the smoke emission piece, before opening the door for the food. During the process of getting the food, it is alive to take the precaution of anti-scald and advised to wear the anti-scale gloves.
- 15.Please repair the machine by entrusting the professional staffs or under the guidance of manufacturer.
- 16.Please clean the machine with the wet or dry towel but not with the water directly.

1. Install the handle.

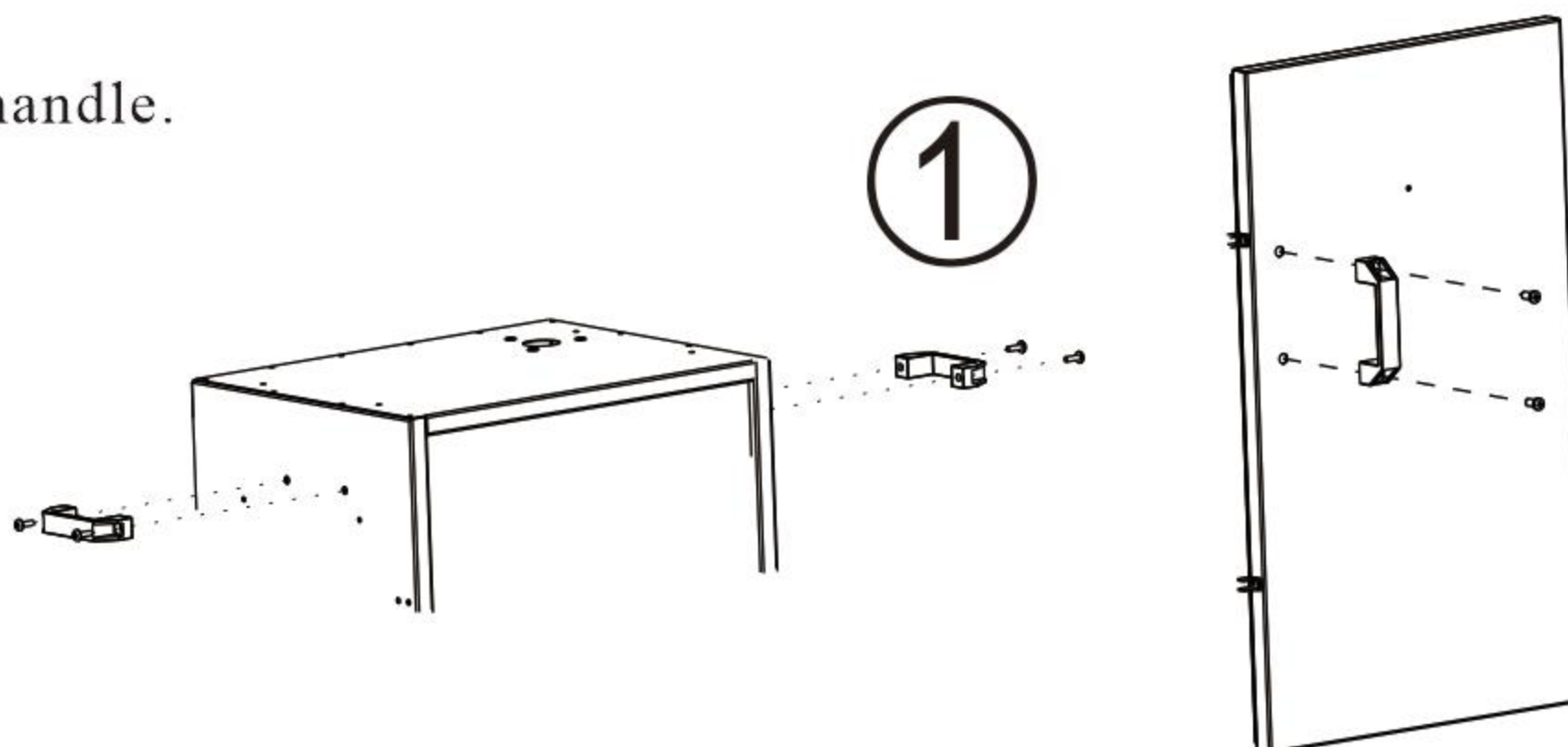

2. Put the silicon gasket on the top of smoke outlet, fasten the chimney assembly with the screws.

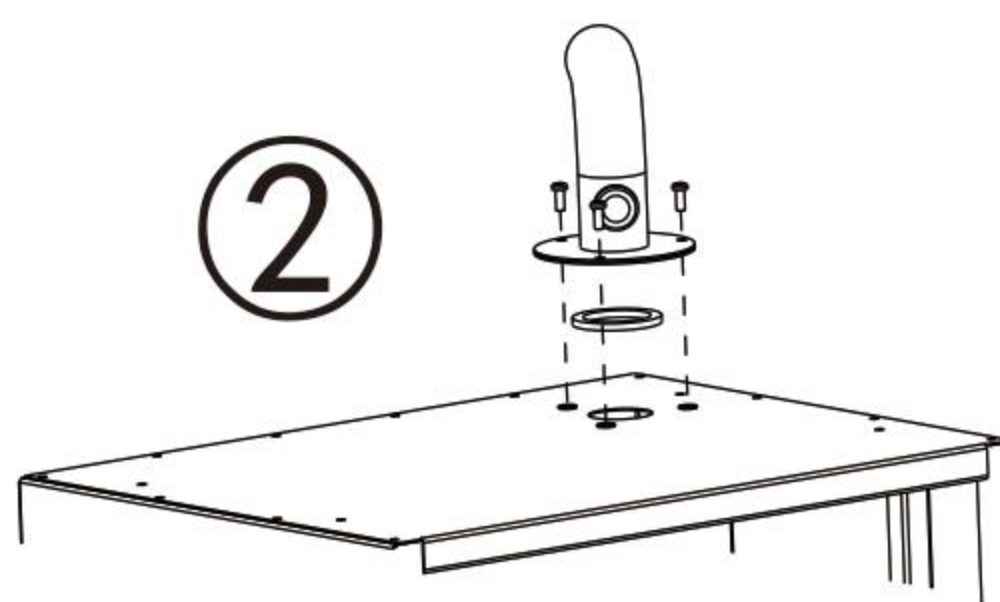

3. (1) Pull the thermo-couple wire through the left round hole, then fasten the control box with the screws.
 (2) As the picture shows: Fasten the inductor slantingly (hold down the end of probe but not the middle or the head of probe, as the the middle and the head of probe are the inductive part), then cover the hold of cabinet body with the rubber plug.

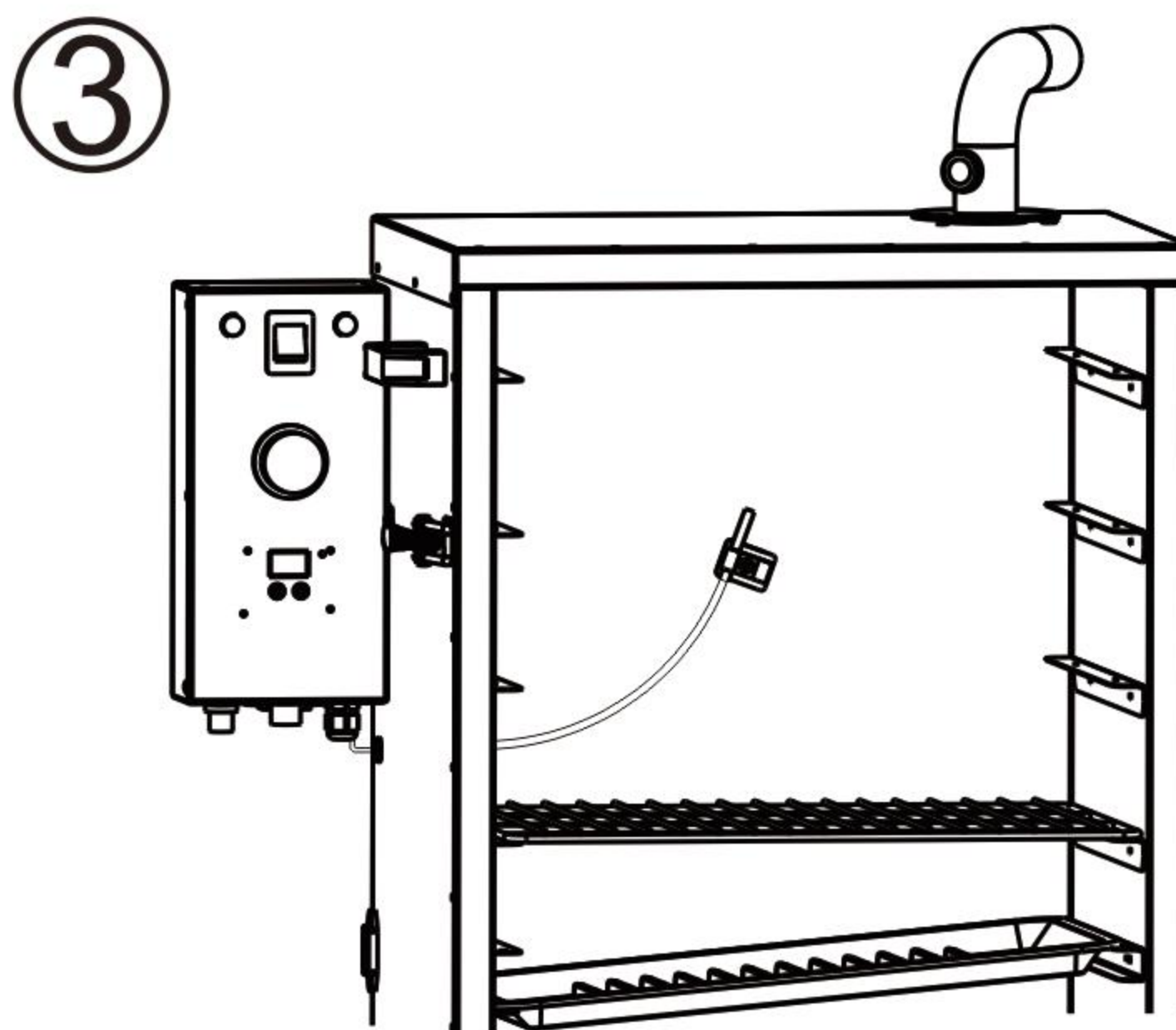

4. Put in the oil guide tray, then put in the oil guide basin (aims at the oil outlet of oil guide tray)

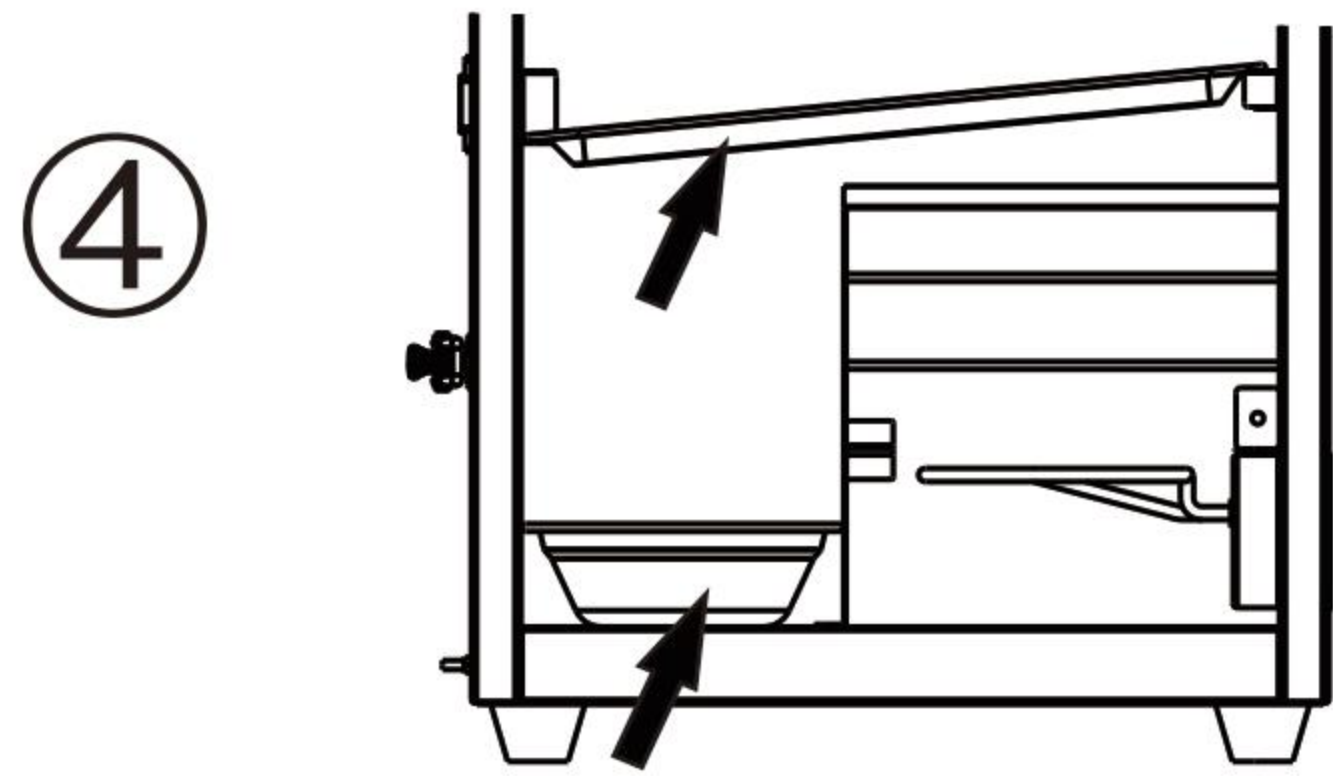

5.(1) #Shelf: Put the desired shelves on the guide plates, then put the desired food on the desired shelves.

(2) #Low temperature orifice plate: Put the low temperature orifice plate into the bottom of heating tube, and put it out when the machine is smoked in the high temperature.

3. #Wood chips box: Put the wood chips into the wood chips box, then put the wood chips box on the top of the heating tube.

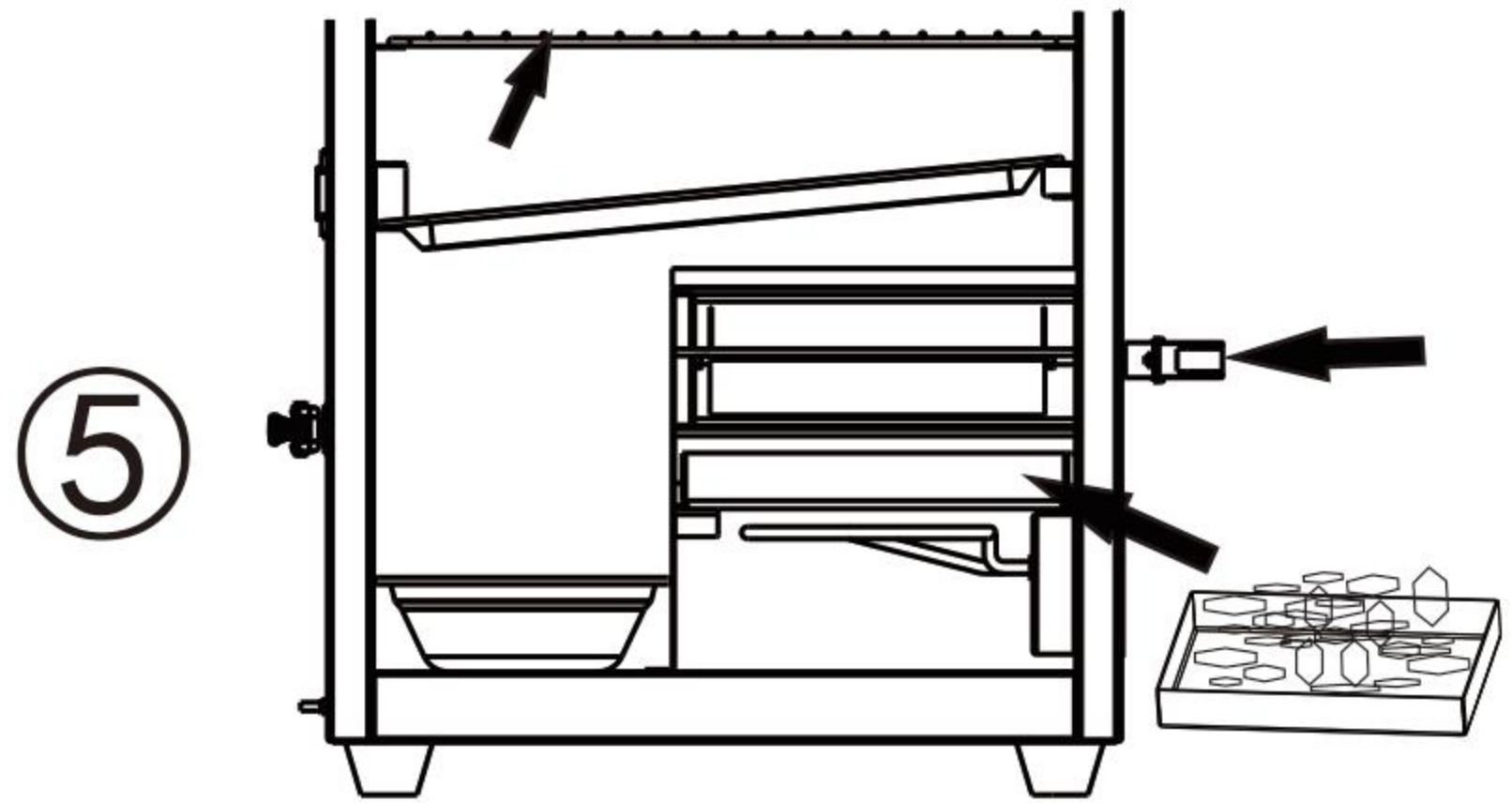

6. As the picture shows: Insert the plug of control box () into the socket of cabinet body, then insert the other power cord into the control box & the power socket.

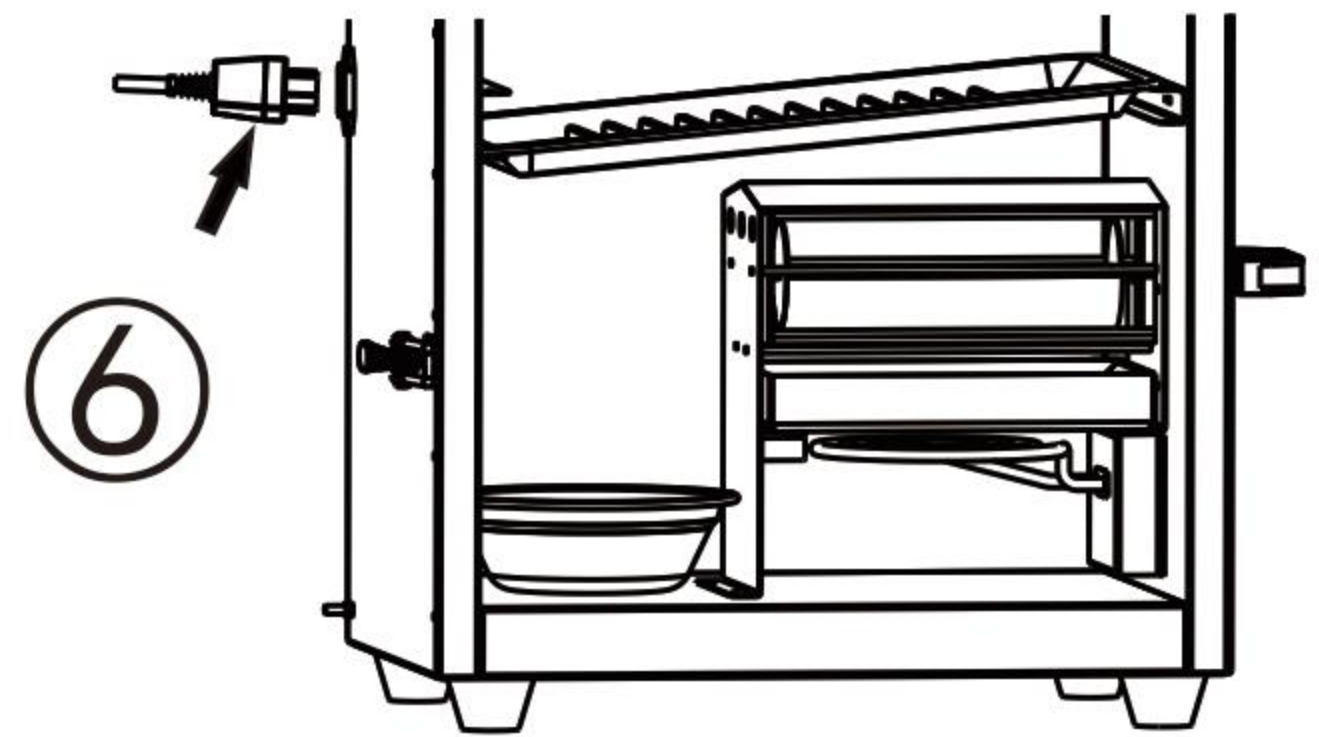

8. If the machine is used indoor, please feel free to connect the pipe to the chimney, in order to emit the smoke to outside.

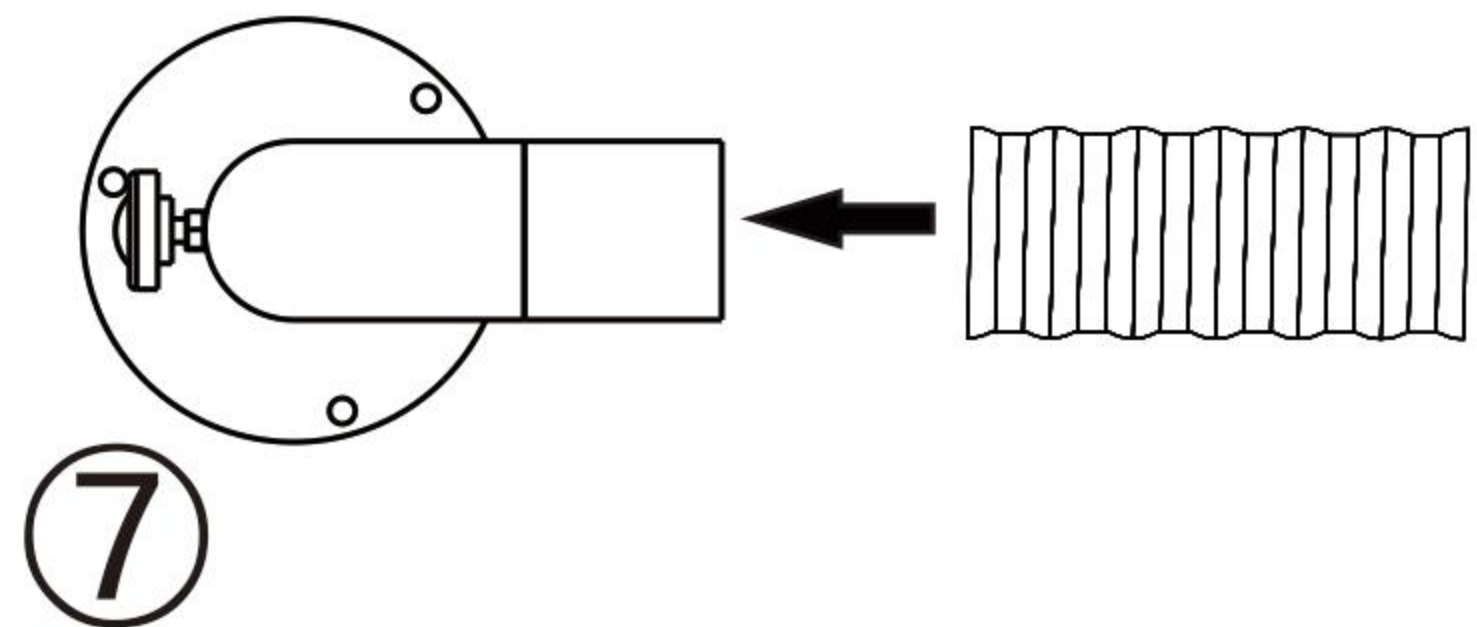

TECHNICAL PARAMETER SUBJECT TO CHANGE WITHOUT NOTICE

CHAPTER 4 OPERATION INSTRUCTION AND EXCEPTION HANDLING

1. Panel Operation

Notices: Please ensure to read the following contents before operation:

(1) Power on: When it's powered on, press the "POWER" (power switch), then the "POWER LIGHT" will be on;

(2) Time setting: Rotate the knob to aim at the number (unit: Hour) on dial; The white area between "0" & "12" on timer is the dial which has been powered on. This dial doesn't play a part in the timing. It's not advised to use this dial when the temperature setting is higher than 100°C (212°F).

(3) The temperature control can be powered on when the timer has been set. Then, the temperature control will show the recent temperature.

Temperature setting: 1. Set the smoking temperature between 30 & 120°C (86 & 248°F): Long press "▼" till it flashes→press "▲" or "▼" to set the desired temperature→done (the temperature will be saved after the hands are loosen for 3 seconds).

2. Check the temperature already set: Press the "▼" of "TEMPERATURE CONTROL" once, the monitor will show the temperature already set in last time; After loosening the hands for 3 seconds, the monitor will return to the recent temperature.

3. Working principle: When the temperature inside the cabinet body is heated up to the setting temperature of temperature control, the heating tube will stop heating up automatically; when the temperature inside the cabinet body is cooled down lower than the setting temperature 2°C (35.6°F) of temperature control, the heating tube will heat up again and work circularly in the setting time of timer.

4. Machine function: It's mainly for smoking as well as dry roast. The size of wood chips can cause the differences of category & ignition. During use, if finding the wood chips are difficult to burn, the user can raise the temperature appropriately or replace the smaller wood chips.

5. The hindrance to burning out the heating tube: When the temperature is set more than 100°F, take down the #19 (Low temperature orifice plate) , and it's advised to use the wooden blocks less than 3cm, as the big wooden blocks are easy to cause fire and burn out the heating tube (the low temperature orifice plate plays a part in letting the small wood chips burn between 35°C and 50°C (95°F and 122°F) and improving the efficiency in cold smoking).

6. Exception handling: (1) When the temperature control shows the same temperature: check whether the temperature already set is lower than the ambient temperature ; (2) When the temperature control shows HHH: If the temperature is more than 130°C (266°F), the temperature control will show HHH, and if the temperature is reduced, there's no need to handle the temperature control as it will recover automatically; (3) The manual feeding assembly pops up when the wood chips are burning: Open the chimney assembly & push the manual feeding assembly into the cabinet. (4) When the temperature control shows LLL: The inductive head is disconnected or damaged. Please power off & take apart the cover of control box, then check & plug or replace the inductive head; (5) !!! During use, all the lights in control box are turned off means the fuse has been damaged (maybe the fuse has gone wrong); The power supply of control box must be cut off and the power plug of control box already inserted into the cabinet body must be pulled off. Repair the heating tube (The multi-meter can be used to check whether the metal housing of cabinet body has been connected with the pin of heating tube) inside the cabinet followed by the control box (Just replace a fuse with same specification). The machine can be powered on when the heating tube inside the cabinet and the control have been finished repairing.

Notice: The (4) & (5) are the repair plan supplied by the professional staffs. Please repair the machine by entrusting the professional staffs or under the guidance of manufacturer.

TECHNICAL PARAMETER SUBJECT TO CHANGE WITHOUT NOTICE

2. Operation

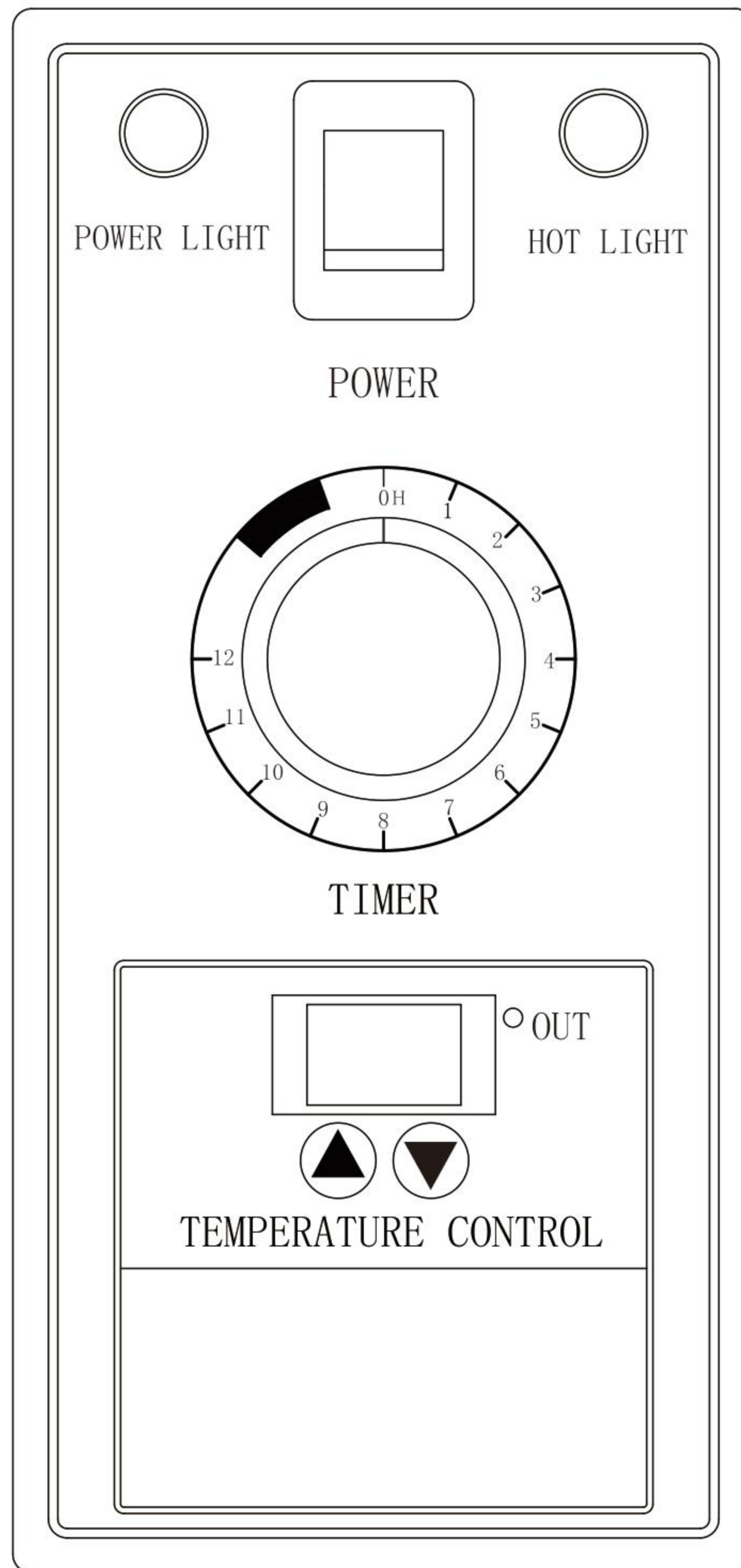

The example of using temperature control:

For example: Smoking the meat as 70°C (158°F) for 5 hours.

1. Setting method: Power on → press the "POWER" → rotate the knob of "TIMER" into the "5" on dial → long press the "▼" of "TEMPERATURE CONTROL" till it flashes → press the "▲" or "▼" to set the temperature as 70°C (158°F) → done (the temperature will be saved automatically when the hands are loosen)

2. Check the temperature already set: Press the "▼" of "TEMPERATURE CONTROL" once.

3. Notice: The temperature control will be powered on & lighted up after setting time.

TECHNICAL PARAMETER SUBJECT TO CHANGE WITHOUT NOTICE

CHAPTER 5 EXPLODED VIEW AND SPARE PARTS LIST

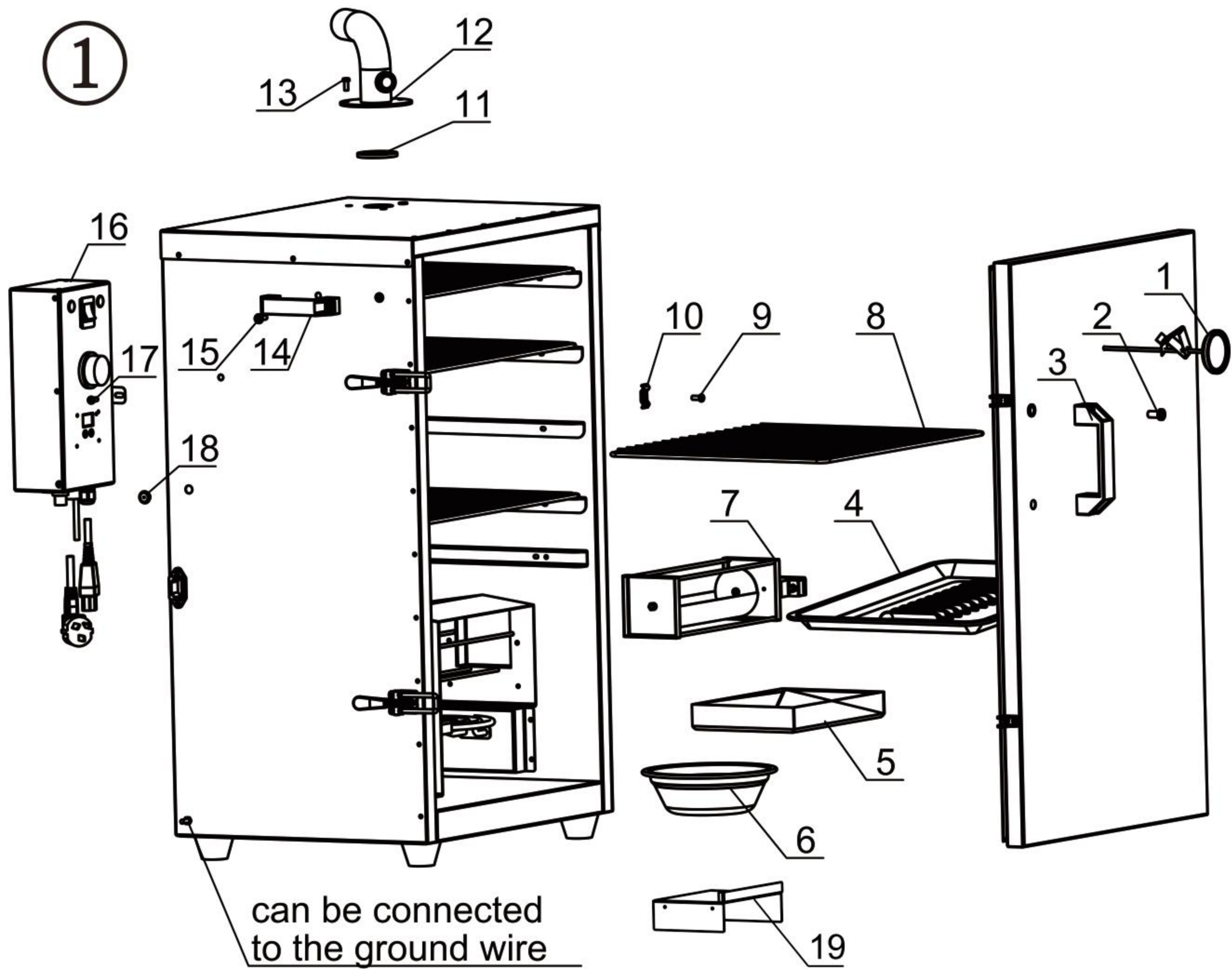

No.	Name	Qty	No.	Name	Qty
1	Thermometer	1PC	10	Tube clamp	1PC
2	Screw	2PCS	11	Silicone gasket	1PC
3	Big handle	1PC	12	Chimney assembly	1PC
4	Oil guide tray	1PC	13	Screw	3PCS
5	Wood chips box	1PC	14	Small handle	2PCS
6	Oil guide basin	1PC	15	Screw	4PCS
7	Manual feeding assembly	1PC	16	Control box (with the power cord)	1PC
8	Shelf	4-8PCS	17	Screw	3PCS
9	Screw	1PC	18	Silicone rubber (in the control box)	0
			19	Low temperature orifice plate	1PC

Notice: For "4-8PCS" of #8, "4" is the qty of DSH-S20B, and "8" is the qty of DSH-S50B.
#8 is 395*320*7.3mm.

TECHNICAL PARAMETER SUBJECT TO CHANGE WITHOUT NOTICE

CHAPTER 6

EXPLODED VIEW OF CONTROL BOX

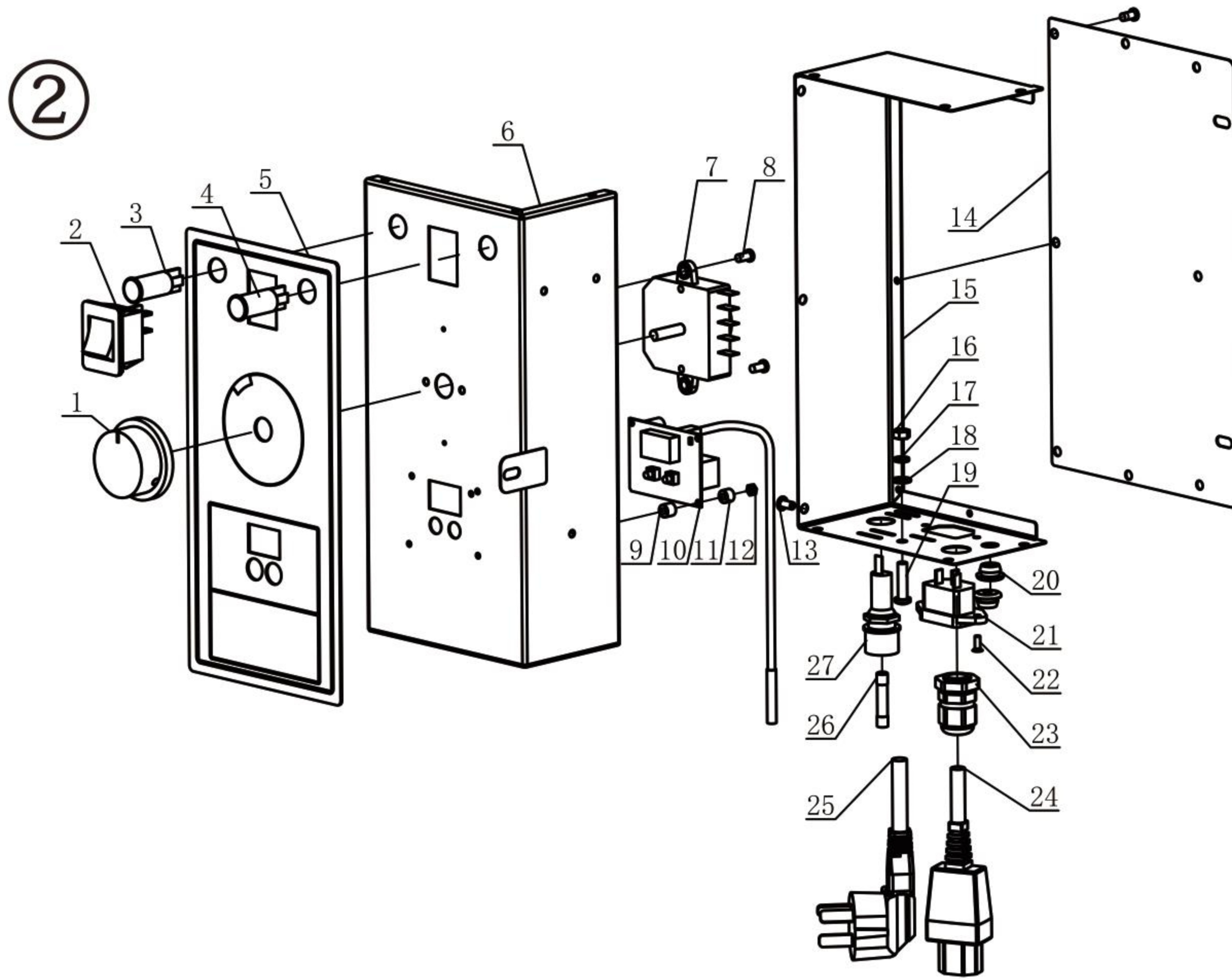

No.	Name	Qty	No.	Name	Qty
1	Knob	1	16	Nut	1
2	Switch	1	17	Spring washer	1
3	Power light	1	18	Flat gasket	1
4	Working light	1	19	Rivet	1
5	Panel	1	20	Silica gel plug	2
6	Front cover assembly	1	21	Socket	1
7	Timer	1	22	Screw	2
8	Screw	10	23	Lock wire buckle	1
9	Gel column (long)	4	24	Plug	1
10	Temperature control	1	25	Power cord	1
11	Gel column (short)	4	26	Fuse	1
12	Nut	6	27	Fuse seat	1
13	Rivet	9			
14	Back cover	1			
15	Housing	1			

Notice: #28 is used 15A in 110V & 8A in 220V.

TECHNICAL PARAMETER SUBJECT TO CHANGE WITHOUT NOTICE

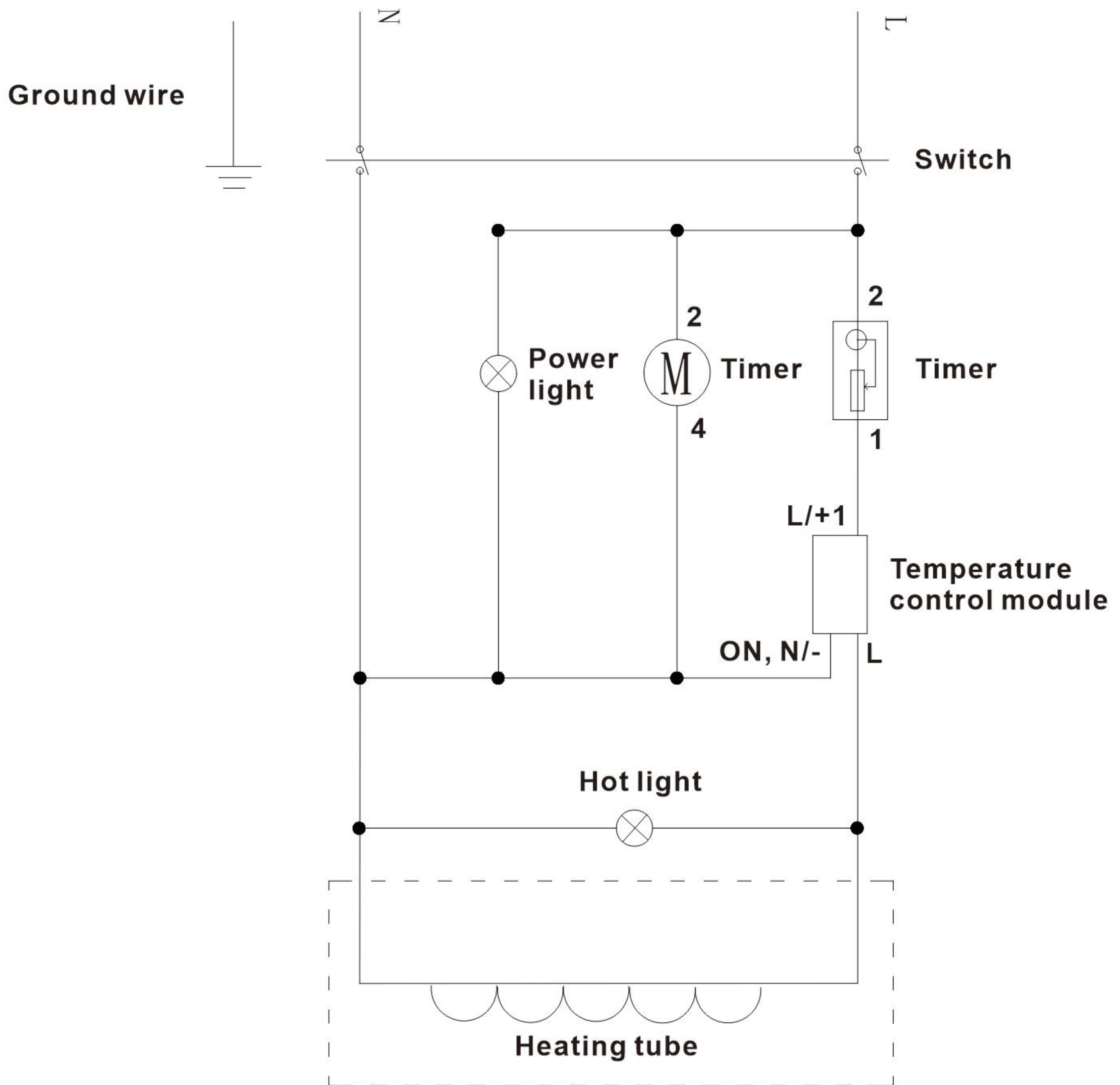

Product specification

Model	Power (W)	Temperature	Time (h)	QTY of layer	Interval of shelf	Material of cabinet body	Layer of thermal insulation	Product size (mm)
DSH-S20B	1000	30~120°C (86~248°F)	0~12	5	95	S/S	Double	640*450*910
DSH-S50B	1000	30~120°C (86~248°F)	0~12	9	95	S/S	Double	640*450*1300
DSH-C20B	1000	30~120°C (86~248°F)	0~12	5	95	Spray coated	Double	640*450*910
DSH-C50B	1000	30~120°C (86~248°F)	0~12	9	95	Spray coated	Double	640*450*1300
DSH-D20B	1000	30~120°C (86~248°F)	0~12	5	95	Galvanized	Double	640*450*910
DSH-D50B	1000	30~120°C (86~248°F)	0~12	9	95	Galvanized	Double	640*450*1300

TECHNICAL PARAMETER SUBJECT TO CHANGE WITHOUT NOTICE

WARRANTY REGISTRATION
RELEASE TYPE OR PRINT CLEARLY



NAME _____

ADDRESS _____

CITY _____ STATE _____ ZIP CODE _____

PHONE _____ PURCHASE DATE _____

PROUDUCT MODEL: _____

Purchased for: Commercial use Personal use Other

Purchased by: _____

Products purchased from: Store Internet

THIS CARD MUST BE SENT TO THE STORE WHERE YOU
PURCHASED TO VALIDATE WARRANTY

WARRANTY REGISTRATION
RELEASE TYPE OR PRINT CLEARLY



NAME _____

ADDRESS _____

CITY _____ STATE _____ ZIP CODE _____

PHONE _____ PURCHASE DATE _____

PROUDUCT MODEL: _____

Purchased for: Commercial use Personal use Other

Purchased by: _____

Products purchased from: Store Internet

THIS CARD MUST BE SENT TO THE STORE WHERE YOU
PURCHASED TO VALIDATE WARRANTY