

VEVOR[®]

TOUGH TOOLS, HALF PRICE

Technical Support and E-Warranty Certificate

www.vevor.com/support

ELECTRONIC DRUM SET USER MANUAL

MODEL: MD200C

We continue to be committed to provide you tools with competitive price. "Save Half", "Half Price" or any other similar expressions used by us only represents an estimate of savings you might benefit from buying certain tools with us compared to the major top brands and does not necessarily mean to cover all categories of tools offered by us. You are kindly reminded to verify carefully when you are placing an order with us if you are actually Saving Half in comparison with the top major brands.

VEVOR[®]

TOUGH TOOLS, HALF PRICE

ELECTRONIC DRUM SET

MODEL: MD200C

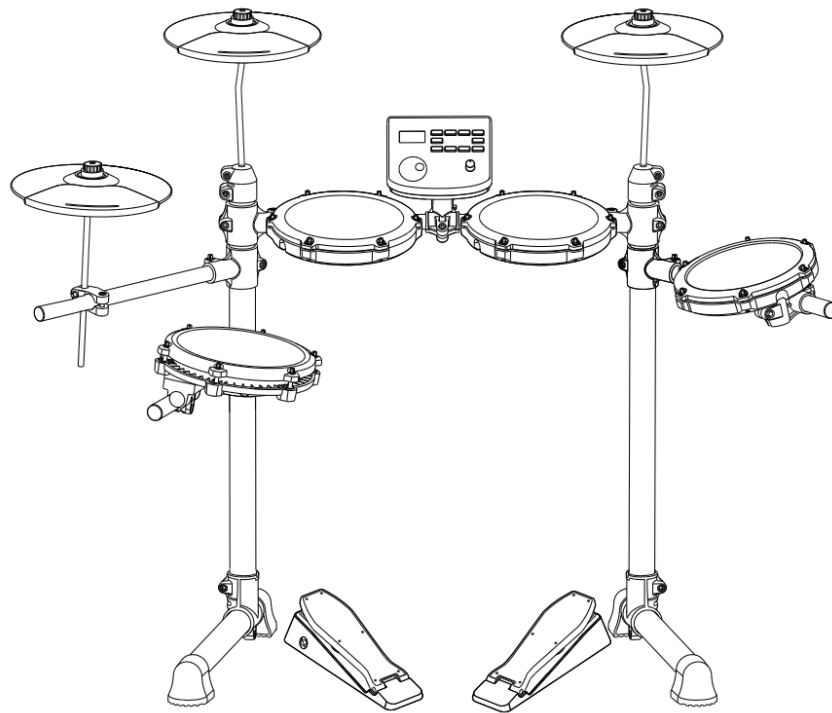

(The picture is for reference only, please refer to the actual object)

NEED HELP? CONTACT US!

Have product questions? Need technical support? Please feel free to contact us:

Technical Support and E-Warranty Certificate
www.vevor.com/support

This is the original instruction, please read all manual instructions carefully before operating. VEVOR reserves a clear interpretation of our user manual. The appearance of the product shall be subject to the product you received. Please forgive us that we won't inform you again if there are any technology or software updates on our product.



FUNCTION INTRODUCTION

Thank you for choosing our electronic drum. Elegant and delicate electronic drum is the perfect combination of modern new electronic technology.

◆Before using this product, you must read the instructions in detail.

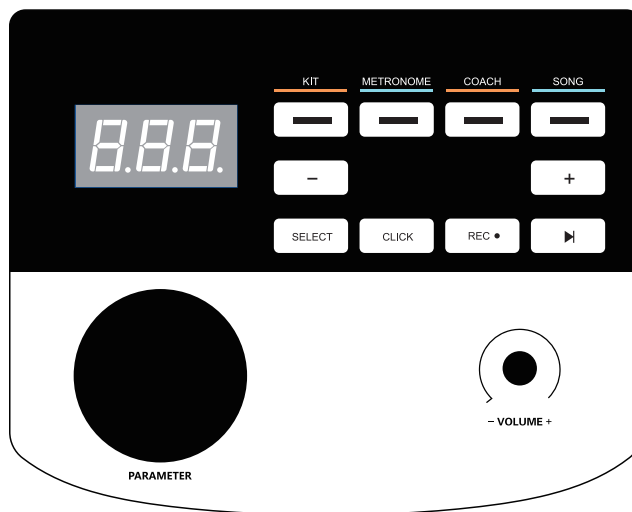

- 15 drum kits, 180 timbres
- 30 songs
- support the adjustment of sensitivity parameters of each drum
- three teaching modes
- speed control: 30 ~ 250 beats / min
- metronome: 1-9 types
- other functions: parameter storage, reset and recording;
- three digit LED display;
- interface: power supply DC, usbmidi, earphone, audio input, audio output
increase cymbal

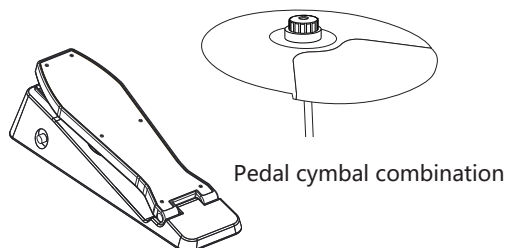

REMARK!

- This product is an electro-acoustic instrument product. It is normal that there is a little current sound in the speaker or earphone after power-on.
Keep away from "radio, TV, antenna receiver, router, refrigerator, TV, motor and other RF electrical interference sources" during using.



CONTENTS

| | |
|---|-----------|
| FUNCTION INTRODUCTION | 1 |
| CONTENS | 2 |
| INSTALLATION GUIDE | 3 |
| CHECK THE ATTACHED ITEMS | 3 |
| STAND PIPE FITTING | 4 |
| MOUNTING STAND | 4 |
| DRUM PAN INSTALLATION | 5 |
| SOUND MODULE INSTALLATION | 5 |
| INSTALL CYMBALS, SOUND MODULE, PLACE PEDALS | 6 |
| INSERT CONNECTING CABLE OF HITTING PART | 7 |
| ILLUSTRATION OF SOUND MODULE PORT | 8 |
| POWER CORD CONNECTION | 8 |
| USB MIDI PORT | 8 |
| AUDIO OUTPUT PORT | 8 |
| AUDIO INPUT PORT | 8 |
| EARPHONE PORT | 8 |
| OPERATION GUIDE | 9 |
| POWER | 9 |
| DRUM KIT SELECTION | 9 |
| METRONOME | 9 |
| PRACTICE FUNCTION | 9 |
| COACH MODE | 9 |
| DEMO SONG | 10 |
| DRUM PARAMETERS | 10 |
| RECORDING FUNCTION | 10 |
| SAVE / RESET | 10 |
| USBMIDI | 10 |
| APPENDIX | 11 |
| DRUM TIMBRE | 11 |
| PRESET DRUM KITS | 11 |
| USER DEFINED DRUM KITS | 11 |
| DEMONSTRATION SONG | 11 |
| PRODUCT MAINTENANCE | 12 |
| SAFETY PRECAUTIONS | 13 |



INSTALLATION GUIDE

REMARK!

- Please follow the instructions and read the "safety precautions" in the User Manual carefully before using .
- This product must be installed by adult , please do not let the minor install it independently.

01

Check the attached items

- After opening the package, please check whether it contains all the items immediately. If there are any missing, please contact your dealer.



Sound module



Module bracket



Cymbal*3

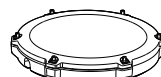

Tom (3pcs)



Snare

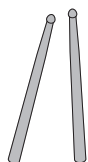

Drum stick

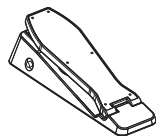

Pedal*2

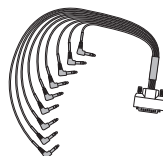

Signal connection cable



Power adapter

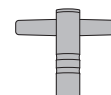

Drum key



Ride/Crash arm



Hi-hat arm



INSTALLATION GUIDE

02

Stand pipe fitting

- The stand is located in a small individual package inside the box.

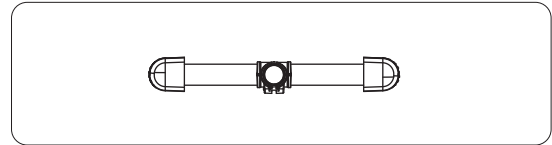
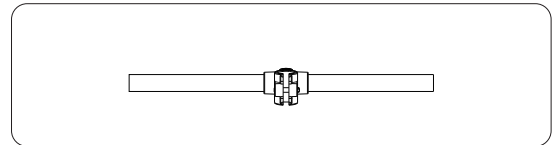
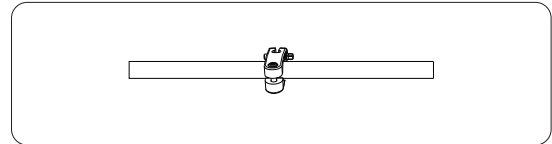
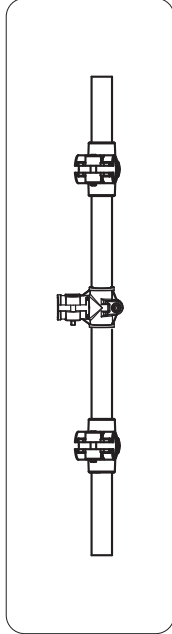
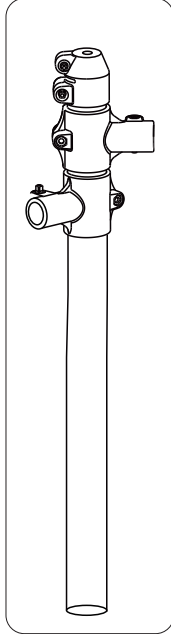
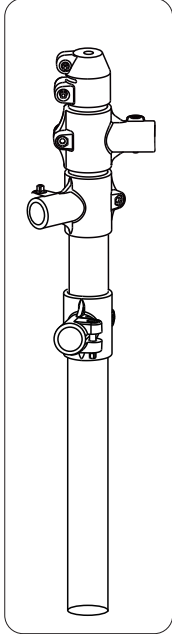

03

Mounting stand

- The stand must be installed in place, and screw down the screws by the drum key.

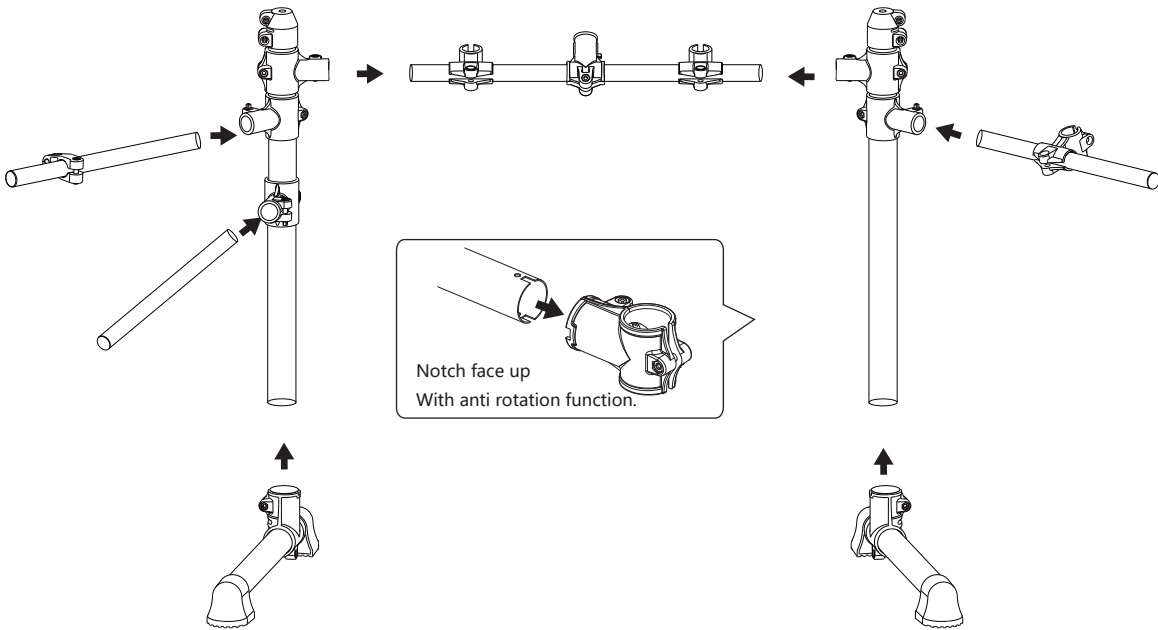



INSTALLATION GUIDE

04

Drum pan installation

- Please be careful and do not to pinch your fingers when installing.

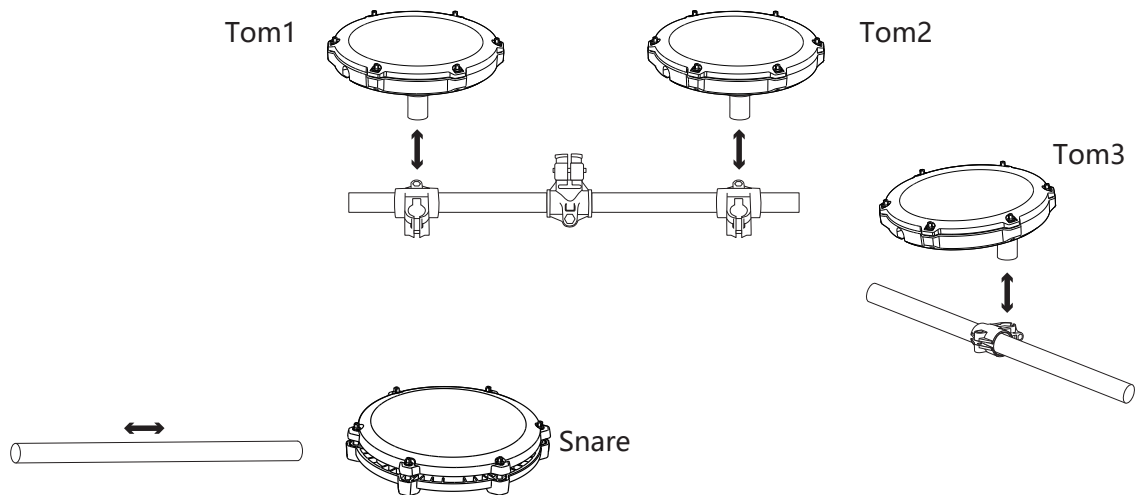

05

Sound module Installation

- Assemble the sound module with the stand before attaching it to the drum kit.

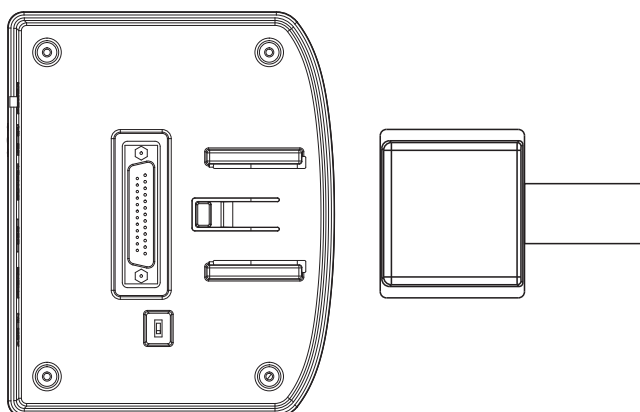

Insert the main box bracket against the sound module track, and you will hear the clicking piece pop up when you insert it to the bottom.



INSTALLATION GUIDE

06

Install cymbals, sound module, place pedals

- Be sure not to tighten the cymbal too tightly, leave some space for them to snake up and down.

Install the cymbal and the sound module on the stand as shown in the picture

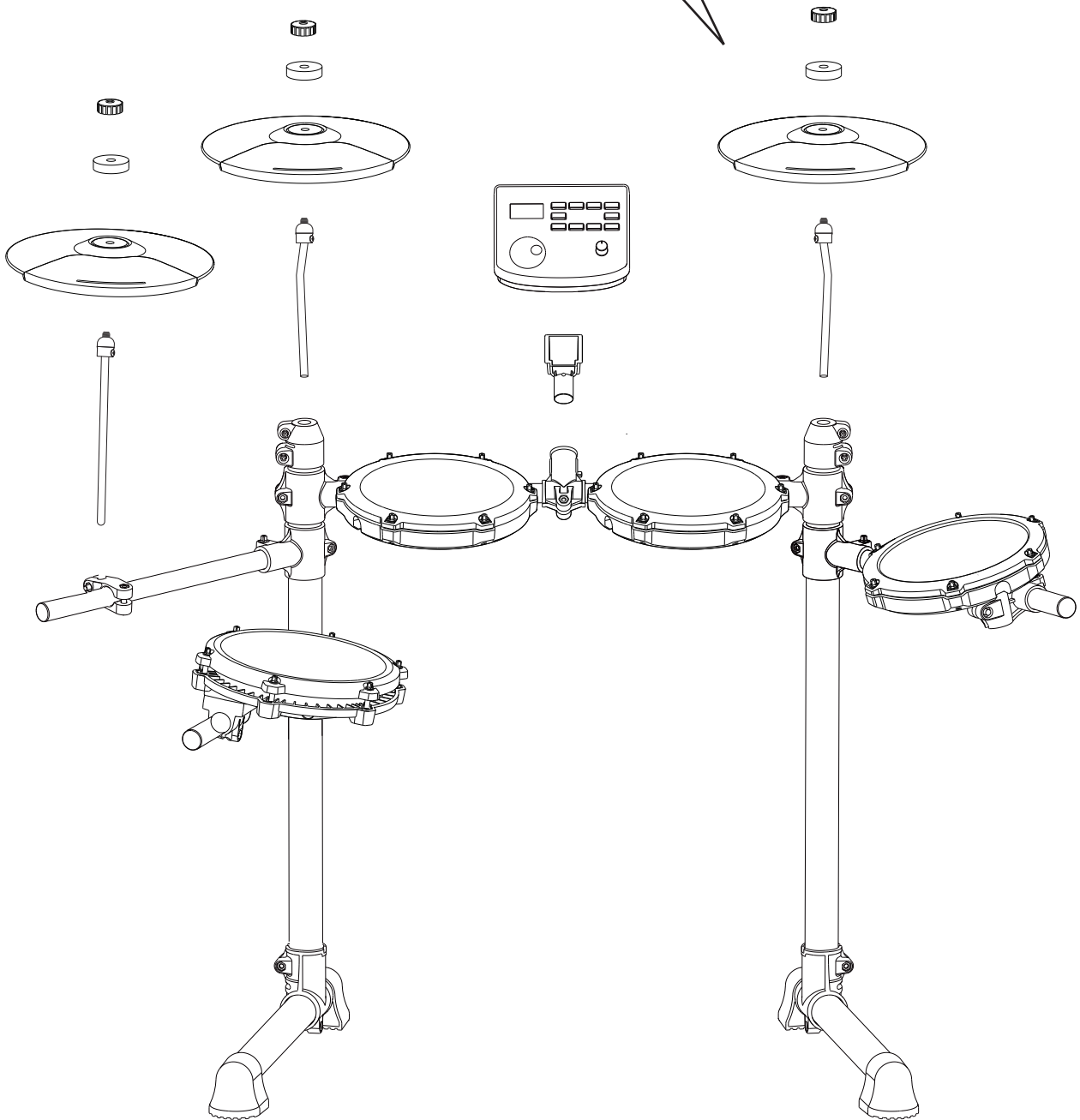
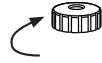



INSTALLATION GUIDE

07

Insert connecting cable of hitting part

• Please insert the connection cable in place to avoid poor contact and insert it correctly as shown in the diagram.

Mode a: mechanical kick drum

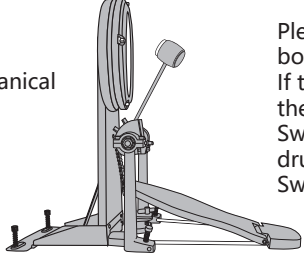

Mode B: pedal

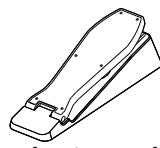

***This product adopts mode B**

Please check whether the bottom drum makes sound, If there is no sound, please turn the switch, Switch in A: mechanical kick drum mode, Switch in B: pedal mode.

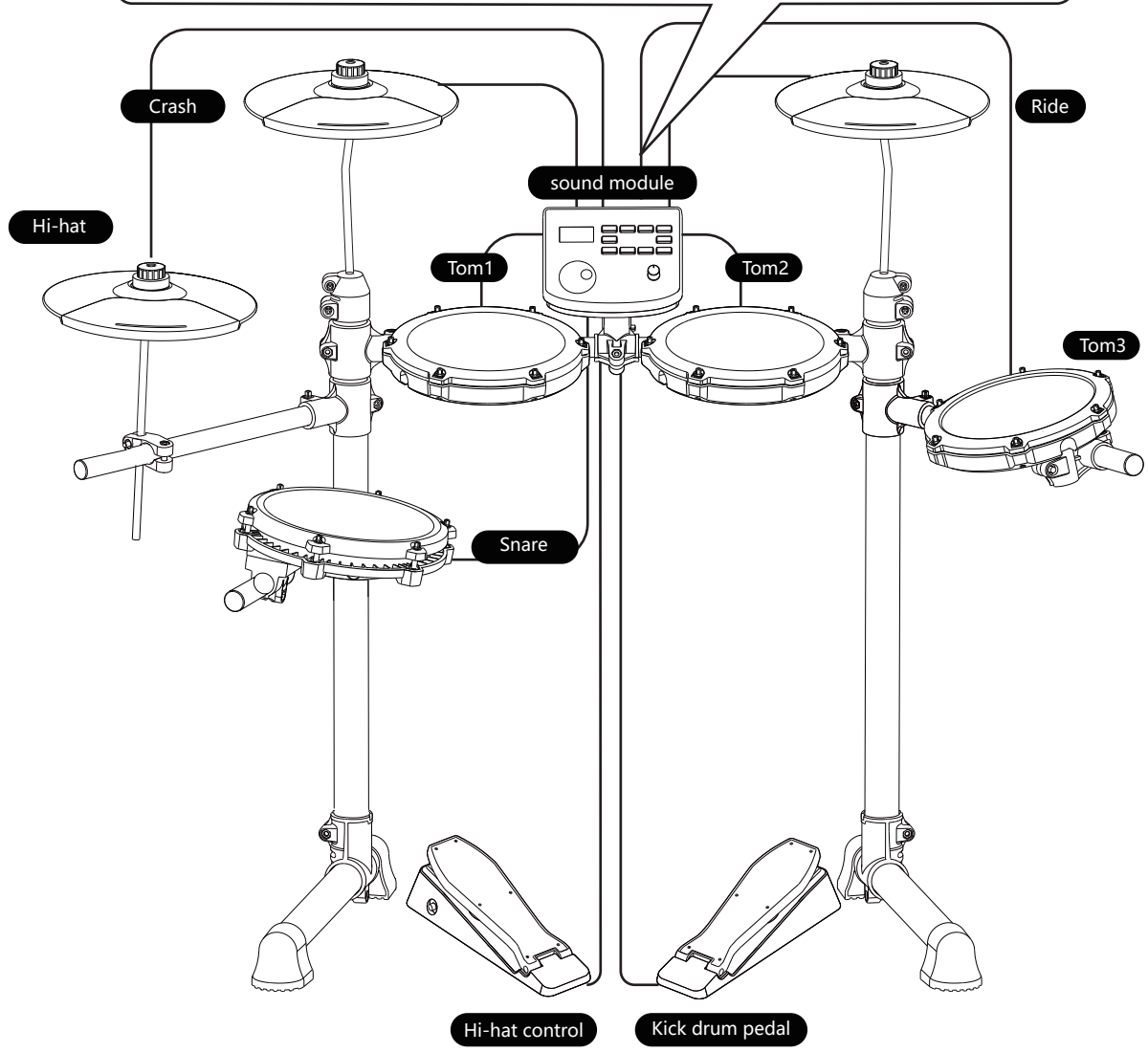
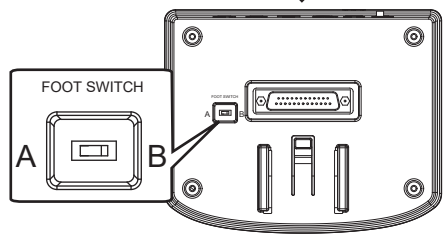
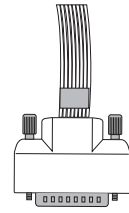
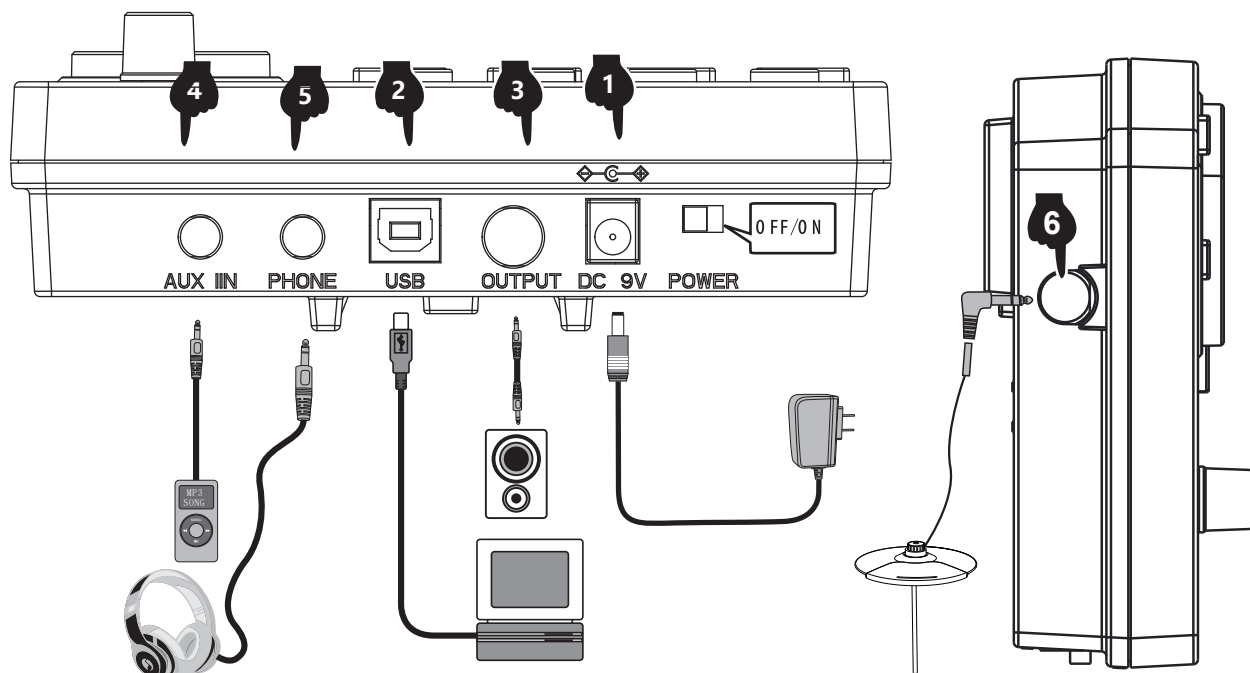



ILLUSTRATION OF SOUND MODULE PORT



1 POWER CORD CONNECTION

1. When in use, connect the power terminal according to the diagram, insert the power outlet of the module box at one end and 100-240V household power outlet at the other end. (Fig. 1)
2. If you do not use this product for a long time, please pull out the power plug and keep it properly.

2 USB MIDI PORT

The use of electronic drum MIDI USB interface can interact with music devices with MIDI.

1. Through the pre-installed Music software on computers and mobile phones, we can learn to play, compose music, store and other functions. (Fig. 2)
2. When connected to a computer or mobile phone, the audio output of the device needs to be connected to the audio input socket of the sound module in order to synchronize the sound effects on the device. (Fig. 5)

3 AUDIO OUTPUT PORT

Audio output port can be connected with active speaker (special electronic drum speaker) and large audio equipment. (Fig. 3)

4 AUDIO INPUT PORT

Audio input port can connect the sound source playback device to the module box for playback (such as MP3, mobile phone and other audio signal input). (Fig. 4)

5 EARPHONE PORT

Connecting headphones monitors the details of percussion and does not disturb others when playing without connecting speakers. (Fig. 5)

6 INCREASE PORT

This port allows you to add a cymbal for easy expansion. (Figure 6)



OPERATION GUIDE

1 POWER

Insert the DC plug into the DC 9V port on the top of the sound module. Slide the POWER switch to the right (viewed from the front) to power up the drum kit. To turn the drum kit off slide the switch to the left.

2 DRUM KIT SELECTION

Press the KIT button to show the current drum kit. Turn the parameter wheel or use the <- /> buttons to select the desired drum kit. There are 15 drum kits to choose from - see drum kit list on page 11.

3 METRONOME

1. Press the METRONOME button to enter the metronome mode.
2. The screen will display the speed value (120 BPM default speed). Turn the parameter wheel or use the +/- buttons to change the metronome speed. Press the CLICK button to start the metronome.
3. Press the SELECT button in metronome mode, and the screen will jump to the metronome parameter adjustment interface. You can press the +/- buttons to select the parameter you want to adjust:
 - A. r (beat type: 2, 4, 8, 16)
 - B. b (beat number: 01-09)
 - C. L (metronome volume: 00 (off) -31), and then turn the parameter wheel to adjust the parameter settings.
4. Once the parameters have been adjusted, press the SELECT button to confirm and exit the parameter interface. Then
5. Use the click button to start and stop the metronome as desired.

4 PRACTICE FUNCTION

The "coach" coach mode of this product can help establish speed, accuracy and endurance, and help cultivate the practice function of a better sense of rhythm. Make progress under the supervision of the "coach" coach mode! Press the "coach" button to enter the coach mode. In this mode, there are three practice modes. Select the practice mode through the data wheel or <+ > <- > button.

1. Exercise mode 1: C-1 beat detection exercise: beat the drum at a fixed speed to train the accuracy of the blow.
2. Practice mode 2: C-2 silent strike mode: the metronome will sound one section and mute one section to train the strike accuracy without metronome prompt. It is an advanced version of practice mode 1.
3. Practice mode 3: C-3 speed strike practice, the metronome will automatically change the speed, increase from the slowest express to the fastest, and then reduce from the slowest express to the slowest speed, so as to practice the strike endurance.

5 COACH MODE

1. The "coach" training mode of this product can help establish speed, accuracy and endurance. Press the COACH button to enter the coach mode. In this mode, there are three practice modes. Use the parameter wheel to select which practice mode.
 - A. Exercise mode 1: C-1 beat detection exercise- beat the drum at a fixed speed to train the accuracy of the blow.
 - B. Practice mode 2: C-2 silent strike mode- the metronome will sound one section and mute one section to train when there is no beat.
 - C. Practice mode 3: C-3 speed strike practice- the metronome will automatically change the speed from the slowest to the fastest and then the fastest to the slowest.
2. Once the coaching mode has been chosen, press the CLICK button. The metronome beats will start and you can play along on the drum for practice.
3. After four preliminary beats, the display will show:



OPERATION GUIDE

(too slow)



(good)



(too fast)



4. Once you have completed the coaching mode a score will be displayed from 0-100 evaluating the accuracy of the exercise.

C-1 mode: Press the SELECT button to enter the parameter setting interface. You can adjust the number of practice sessions as required (01-32). The number of sessions to practice determines the length of this exercise.

C-2 mode: Press the SELECT button to enter the parameter setting interface. You can adjust the number of practice sessions as required (04-32). The number of sessions to practice determines the length of this exercise.

C-3 mode: Press the SELECT button to enter the parameter setting interface. You can adjust the rate at which the BPM changes (01-09 BPM).

5. Press the CLICK button again to end the coach mode.

6 DEMO SONGS

1. Press the SONG button to enter the demo mode, there are 30 demos to choose from. The screen will display the current demo song number (01 -30).
2. Press the <▶I> button to start playing the demo songs. To stop playing press the <▶I> button again.
3. Turn the parameter wheel or press the +/- buttons to select a demo song.
4. Press the SELECT button in song mode to jump to the song parameter setting interface. You can turn the drum sound on or off by turning the parameter wheel (the drum sound is on by default).
5. Press the SELECT button to confirm and exit the parameter interface.

7 DRUM PARAMETERS

1. Press the KIT button and the screen will display 01 (drum kit number). Press SELECT to enter the drum parameter adjustment mode.
2. Tap the drum you want to adjust, and then press the +/- buttons to select the parameter for adjustment. Sensitivity S (01-06). Trigger threshold t (01 - 32). Crosstalk threshold c (01 -32) Repeated trigger r (01-32) Drum Force V (01-03). Drum volume L (00 - 31).
3. Change the parameters by rotating the parameter wheel and long press the - button to save. The screen will display SAV to indicate the parameter adjustment has been saved successfully.
4. To restore the drum parameters back to factory settings long press the + button until the screen displays RES.PLEASE
NOTE: The parameters for the 3 tom drums can not be set individually.

8 RECORDING FUNCTION

1. Press the < REC > button when the indicator light is in the "KIT" and "CLICK" states, and the screen displays the words "REC" in the breathing flashing state, entering the recording preparation state.
2. Tap any drum and the metronome sounds. At this time, the screen displays "---" in the flashing state of breathing and starts recording.
3. Press the < REC > key or < PLAY > key again, the recording stops and "A-1" is displayed on the screen.
4. Press < ▶I > to start playing the current recording, and press again to stop playback.
5. If you enter the recording preparation state again without any knocking, the "A-1" recorded last time is played back.

9 SAVE / RESET

1. To save parameters long press the <-> button and the screen will display SAV.
2. To reset parameters long press the <+> button and the screen will display RES res.

10 USBMIDI

To use the drum kits MID function plug a USB-B data cable (not included with this drum kit) into the control unit and connect to PC/Smartphone.



APPENDIX

Timbre

Kick

- 1 . Funk Kick
- 2 . Original Kick
- 3 . Poprock Kick
- 4 . Rock Kick
- 5 . Seesion Kick
- 6 . SpeedMetal Kick
- 7 . ClassicDry Kick
- 8 . Modern Kick
- 9 . Jazz Kick
- 10 . Blues Kick
- 11 . Popular Kick
- 12 . Fuse Kick
- 13 . Dancehall Kick
- 14 . Synthgaze Kick
- 15 . Standard Kick

Snare

- 16 . Funk Snare
- 17 . Original Snare
- 18 . Poprock Snare
- 19 . Rock Snare
- 20 . Seesion Snare
- 21 . SpeedMetal Snare
- 22 . ClassicDry Snare
- 23 . Modern Snare
- 24 . Jazz Snare
- 25 . Blues Snare
- 26 . Popular Snare
- 27 . Fuse Snare
- 28 . Dancehall Snare
- 29 . Synthgaze Snare
- 30 . Standard Snare
- 31 . Funk Snare Rim
- 32 . Original Snare Rim
- 33 . Poprock Snare Rim
- 34 . Rock Snare Rim
- 35 . Seesion Snare Rim
- 36 . SpeedMetal Snare Rim
- 37 . ClassicDry Snare Rim
- 38 . Modern Snare Rim

- 39 . Jazz Snare Rim
- 40 . Blues Snare Rim
- 41 . Popular Snare Rim
- 42 . Fuse Snare Rim
- 43 . Dancehall Snare Rim
- 44 . Synthgaze Snare Rim
- 45 . Standard Snare Rim

Tom

- 46 . Funk Tom1
- 47 . Original Tom1
- 48 . Poprock Tom1
- 49 . Rock Tom1
- 50 . Seesion Tom1
- 51 . SpeedMetal Tom1
- 52 . ClassicDry Tom1
- 53 . Modern Tom1
- 54 . Jazz Tom1
- 55 . Blues Tom1
- 56 . Popular Tom1
- 57 . Fuse Tom1
- 58 . Dancehall Tom1
- 59 . Synthgaze Tom1
- 60 . Standard Tom1
- 61 . Funk Tom2
- 62 . Original Tom2
- 63 . Poprock Tom2
- 64 . Rock Tom2
- 65 . Seesion Tom2
- 66 . SpeedMetal Tom2
- 67 . ClassicDry Tom2
- 68 . Modern Tom2
- 69 . Jazz Tom2
- 70 . Blues Tom2
- 71 . Popular Tom2
- 72 . Fuse Tom2
- 73 . Dancehall Tom2
- 74 . Synthgaze Tom2
- 75 . Standard Tom2
- 76 . Funk Tom3
- 77 . Original Tom3

- 78 . Poprock Tom3
- 79 . Rock Tom3
- 80 . Seesion Tom3
- 81 . SpeedMetal Tom3
- 82 . ClassicDry Tom3
- 83 . Modern Tom3
- 84 . Jazz Tom3
- 85 . Blues Tom3
- 86 . Popular Tom3
- 87 . Fuse Tom3
- 88 . Dancehall Tom3
- 89 . Synthgaze Tom3
- 90 . Standard Tom3

Crash

- 91 . Funk Crash1
- 92 . Original Crash1
- 93 . Poprock Crash1
- 94 . Rock Crash1
- 95 . Seesion Crash1
- 96 . SpeedMetal Crash1
- 97 . ClassicDry Crash1
- 98 . Modern Crash1
- 99 . Jazz Crash1
- 100 . Blues Crash1
- 101 . Popular Crash1
- 102 . Fuse Crash1
- 103 . Dancehall Crash1
- 104 . Synthgaze Crash1
- 105 . Standard Crash1
- 106 . Funk Crash2
- 107 . Original Crash2
- 108 . Poprock Crash2
- 109 . Rock Crash2
- 110 . Seesion Crash2
- 111 . SpeedMetal Crash2
- 112 . ClassicDry Crash2
- 113 . Modern Crash2
- 114 . Jazz Crash2
- 115 . Blues Crash2

- 116 . Popular Crash2
- 117 . Fuse Crash2
- 118 . Dancehall Crash2
- 119 . Synthgaze Crash2
- 120 . Standard Crash2

Ride

- 121 . Funk Ride
- 122 . Original Ride
- 123 . Poprock Ride
- 124 . Rock Ride
- 125 . Seesion Ride
- 126 . SpeedMetal Ride
- 127 . ClassicDry Ride
- 128 . Modern Ride
- 129 . Jazz Ride
- 130 . Blues Ride
- 131 . Popular Ride
- 132 . Fuse Ride
- 133 . Dancehall Ride
- 134 . Synthgaze Ride
- 135 . Standard Ride

HiHat

- 136 . Funk Hi-Hat Open
- 137 . Original Hi-Hat Open
- 138 . Poprock Hi-Hat Open
- 139 . Rock Hi-Hat Open
- 140 . Seesion Hi-Hat Open
- 141 . SpeedMetal Hi-Hat Open
- 142 . ClassicDry Hi-Hat Open
- 143 . Modern Hi-Hat Open
- 144 . Jazz Hi-Hat Open
- 145 . Blues Hi-Hat Open
- 146 . Popular Hi-Hat Open
- 147 . Fuse Hi-Hat Open
- 148 . Dancehall Hi-Hat Open
- 149 . Synthgaze Hi-Hat Open
- 150 . Standard Hi-Hat Open
- 151 . Funk Hi-Hat Close
- 152 . Original Hi-Hat Close





APPENDIX

- | | | |
|-------------------------------|-------------------------------|------------------------------|
| 153 . Poprock Hi-Hat Close | 163 . Dancehall Hi-Hat Close | 173 . Modern Hi-Hat Pedal |
| 154 . Rock Hi-Hat Close | 164 . Synthgaze Hi-Hat Close | 174 . Jazz Hi-Hat Pedal |
| 155 . Seesion Hi-Hat Close | 165 . Standard Hi-Hat Close | 175 . Blues Hi-Hat Pedal |
| 156 . SpeedMetal Hi-Hat Close | 166 . Funk Hi-Hat Pedal | 176 . Popular Hi-Hat Pedal |
| 157 . ClassicDry Hi-Hat Close | 167 . Original Hi-Hat Pedal | 177 . Fuse Hi-Hat Pedal |
| 158 . Modern Hi-Hat Close | 168 . Poprock Hi-Hat Pedal | 178 . Dancehall Hi-Hat Pedal |
| 159 . Jazz Hi-Hat Close | 169 . Rock Hi-Hat Pedal | 179 . Synthgaze Hi-Hat Pedal |
| 160 . Blues Hi-Hat Close | 170 . Seesion Hi-Hat Pedal | 180 . Standard Hi-Hat Pedal |
| 161 . Popular Hi-Hat Close | 171 . SpeedMetal Hi-Hat Pedal | |
| 162 . Fuse Hi-Hat Close | 172 . ClassicDry Hi-Hat Pedal | |

Drum combination timbre

User drum kit

- | | | | | |
|-------------|---------------|---------------|------------|--------------|
| 01 Funk | 04 Rock | 07 ClassicDry | 10 Blues | 13 Dancehall |
| 02 Original | 05 Seesion | 08 Modern | 11 Popular | 14 Synthgaze |
| 03 Poprock | 06 SpeedMetal | 09 Jazz | 12 Fuse | 15 Standard |

Demostration song

- | | | | | | | | |
|----------|----------|----------|----------|----------|----------|----------|----------|
| Song 001 | Song 005 | Song 009 | Song 013 | Song 017 | Song 021 | Song 025 | Song 029 |
| Song 002 | Song 006 | Song 010 | Song 014 | Song 018 | Song 022 | Song 026 | Song 030 |
| Song 003 | Song 007 | Song 011 | Song 015 | Song 019 | Song 023 | Song 027 | |
| Song 004 | Song 008 | Song 012 | Song 016 | Song 020 | Song 024 | Song 028 | |



PRODUCT MAINTENANCE

Careful maintenance and protection of the product, to extend the service life of the product, reduce the fault has a very important role.

1 AVOID HEATING, DAMPNES OR DIRECT SUNLIGHT

Do not over expose the product to direct sunlight, or place it near air conditioning or extremely hot place.

2 DO NOT USE NEAR THE TV OR RADIO

This product may cause video or audio interference to the reception of TV and radio. If this happens, the product should be removed from the TV or radio.

3 NO DILUENTS OR SIMILAR CHEMICALS SHOULD BE USED FOR CLEANING

Clean the product with a soft cloth wetted with weak water solution and neutral detergent. Soak the cloth in a solution and wring it dry until it approaches drying.

4 DO NOT SHAKE, AVOID COLLISION

When moving, the product should be handled carefully and lightly. Violent vibration and collision are strictly prohibited in order to avoid damage to the shell or internal electronic components.



SAFETY PRECAUTIONS

POWER SUPPLY

This product can be powered by standard indoor wall sockets. Please only use the power cord specified in this product. When not in use, please turn off the power supply. When not in use for a long time, pull out the power cord and keep it properly.

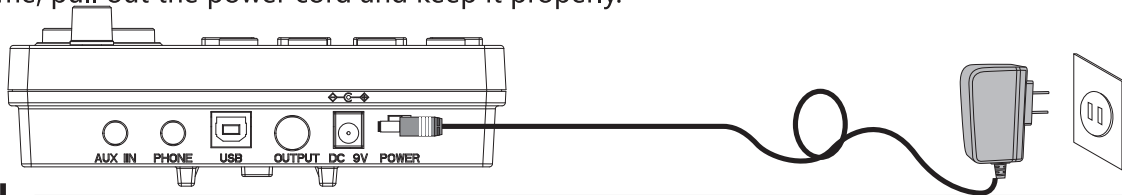

SIGN

To ensure that you use this product safely and correctly, to prevent harm to users and others and financial damage, this manual and products are marked with a series of safety signs. The various signs and their meanings are as follows:

WARNING

This sign indicates that there is a potential risk of death or serious injury if this mark is ignored and the product is mishandled.

BE CAREFUL

This sign indicates that there is a potential danger of injury to personnel or other financial damage if this sign is ignored and the product is operated incorrectly.

EXAMPLE OF LOGO



This triangle sign (Δ) indicates what users should pay attention to. (The left example is careful shocks)



A circular sign (\ominus) with an oblique line indicates prohibitions. The icons in or beside the logo indicate the contents specifically prohibited. (The example on the left is no disassembly)



The round black bottom sign (\odot) indicates what must be observed. The diagrams in this sign indicate the contents of the specific matters that must be observed. (The example on the left is that the power plug must be pulled out of the socket)



SAFETY PRECAUTIONS

WARNING

Smoke, odor, overheating

When the product smokes, smells or overheats, there is a danger of fire and electric shock when it is used continually. In case of the above situation, the following operations should be performed immediately:

1. Turn off the power supply.
2. Pull the plug out of the power outlet.
3. Contact your dealer.

Power cord

1. The improper use of power cord may cause fire and electric shock. The following precautions must be observed:

- The special power cord designated for this product must be used.
- The AC power supply with output voltage within the rated voltage range for household use must be used.
- Do not overload power sockets and extension lines.



2. The improper treatment of power line will lead to its damage or breakage, which will cause fire and electric shock hazards. The following precautions must be observed:

- Do not place or heat heavy objects on power lines.
- Do not attempt to alter or bend the power cord too much.
- Do not twist or pull the power cord.
- If the power cord or plug is damaged, please replace the same type of power cord.



3. Do not touch the power cord and plug with wet hands, otherwise there is a danger of electric shock.



4. Please use the power cord where the water will not splash. Water is in danger of causing fire and electric shock.



5. Never place vases or any other container containing water on this product. Water is dangerous of causing fire and electric shock.



6. Do not allow minors to unplug and touch power lines or connection boards. Minors have no common sense of electricity safety, which may cause electric shock.



BE CAREFUL

The improper use of power cord may cause fire and electric shock. The following precautions must be observed:

- Never put the power cord near the oven or other heat source.
- Do not pull the cable when pulling out of the power socket. The main body of the plug must be grasped.
- The power cord plug must be inserted in the socket to the end.
- Make sure the power supply is off before connecting or disconnecting it.
- When thunderstorms occur or before traveling or other long-term departure, disconnect the power cord from the wall outlet.
- At least once a year, remove the power cord from the wall outlet and clean the dust accumulated around the plug.



Do not burn this product

Do not put this product in the fire, otherwise it will lead to product combustion and explosion of internal electronic components, which will cause fire and personnel injury.



Water and foreign bodies

Water, other liquids and (metal sheets, etc.) entering this product are in danger of causing fire and electric shock. In case of the above situation, the following operations shall be performed immediately:



1. Turn off the power supply.
2. If you are using a power cord for power supply, unplug it from the wall outlet.
3. Contact your distributor.

Disassembly and transformation

Do not disassemble or transform the product in any way, otherwise there is a risk of electric shock, scald or other personal injury. All internal inspection, adjustment and maintenance operations should be entrusted to your distributor.





SAFETY PRECAUTIONS

Falling or colliding

If the product falls or is damaged by strong impact, it will be in danger of causing fire and electric shock. In case of the above situation, the following operations shall be performed immediately:

1. Turn off the power supply.
2. If you are using a power cord for power supply, you need to unplug it from the wall outlet.
3. Contact your distributor.



Plastic bag

Do not let anyone put plastic bags for this product on his head or in his mouth.

Otherwise, there is a risk of asphyxia.

Families with young children should pay special attention to it.



Keep a distance from the product and the bracket

Climbing the bracket is dangerous of overturning or damage. Families with young children should pay special attention to it.



Put

Avoid placing the product on an uneven surface or any other unstable place.

Otherwise, it will cause the product to fall down, which will lead to the risk of injury.



Product Mobility

Before moving this product, you must unplug the power cord plug from the wall outlet and pull out all other cables and connecting wires. Otherwise, it will lead to damage of power or connection wires, resulting in fire and electric shock.



clean

Before cleaning this product, you must unplug the power cord plug from the wall outlet, otherwise there is a risk of fire and electric shock.



Jack

The socket of this product can only be connected to the designated equipment and devices. Connecting non-designated equipment or devices is dangerous of causing fire and electric shock.



Location selection

It should be avoided to place the product in the following places, otherwise there is a risk of fire and electric shock.

- High temperature or dusty places.
- Kitchen or other places with lampblack.
- Where the product is exposed to direct sunlight, or any other place where the product will produce high temperature.



Volume

Don't play music long and loud. Pay special attention when using headphones.

Excessive volume can damage your hearing.



Heavy

Do not place heavy objects on this product. Otherwise, the top of the product will be overweight, causing the product to overturn or drop objects on it, which will lead to the risk of injury.





Correct assembly of scaffolds

The incorrect assembly of the bracket may overturn, causing the product to fall off and posing a risk of injury to personnel.

Therefore, it must be assembled according to the instructions in the attached installation guide to ensure that the product is properly mounted on its bracket.



| | |
|--|--|
|  | <p>Warning-To reduce the risk of injury, user must read instructions manual carefully.</p> |
|  | <p>This device complies with Part 15 of the FCC Rules. Operation is subject to the following two conditions:(1)This device may not cause harmful interference, and (2)this device must accept any interference received, including interference that may cause undesired operation.</p> |
|  | <p>This product is subject to the provision of European Directive 2012/19/EC. The symbol showing a wheeled bin crossed through indicates that the product requires separate refuse collection in the European Union. This applies to the product and all accessories marked with this symbol. Products marked as such may not be discarded with normal domestic waste, but must be taken to a collection point for recycling electrical and electronic devices</p> |

Manufacturer: Shanghaimuxinmuyeyouxiangongsi

Address: Shuangchenglu 803nong11hao1602A-1609shi, baoshanqu, shanghai 200000 CN.

Imported to AUS: SIHAO PTY LTD, 1 ROKEVA STREETEASTWOOD NSW 2122 Australia

Imported to USA: Sanven Technology Ltd., Suite 250, 9166 Anaheim Place, Rancho Cucamonga, CA 91730

| | |
|------------------|-------------------|
| <p>EC</p> | <p>REP</p> |
|------------------|-------------------|

E-CrossStu GmbH
Mainzer Landstr.69, 60329 Frankfurt am Main.

| | |
|------------------|-------------------|
| <p>UK</p> | <p>REP</p> |
|------------------|-------------------|

YH CONSULTING LIMITED.
C/O YH Consulting Limited Office 147, Centurion House,
London Road, Staines-upon-Thames, Surrey, TW18 4AX

VEVOR[®]

TOUGH TOOLS, HALF PRICE

Technical Support and E-Warranty Certificate

www.vevor.com/support

VEVOR®

TOUGH TOOLS, HALF PRICE

Assistance technique et certificat de garantie

électronique www.vevor.com/support

BATTERIE ÉLECTRONIQUE

MANUEL DE L'UTILISATEUR

MODÈLE : MD200C

Nous continuons à nous engager à vous fournir des outils à des prix compétitifs.

"Économisez la moitié", "Moitié prix" ou toute autre expression similaire que nous utilisons ne représente qu'une estimation des économies dont vous pourriez bénéficier en achetant certains outils chez nous par rapport aux grandes marques et ne signifie pas nécessairement couvrir toutes les catégories d'outils. proposés par nos soins. Nous vous rappelons de bien vouloir vérifier attentivement lorsque vous passez une commande chez nous si vous économisez réellement la moitié par rapport aux grandes marques.

VEVOR[®]
TOUGH TOOLS, HALF PRICE

BATTERIE ÉLECTRONIQUE

MODÈLE : MD200C

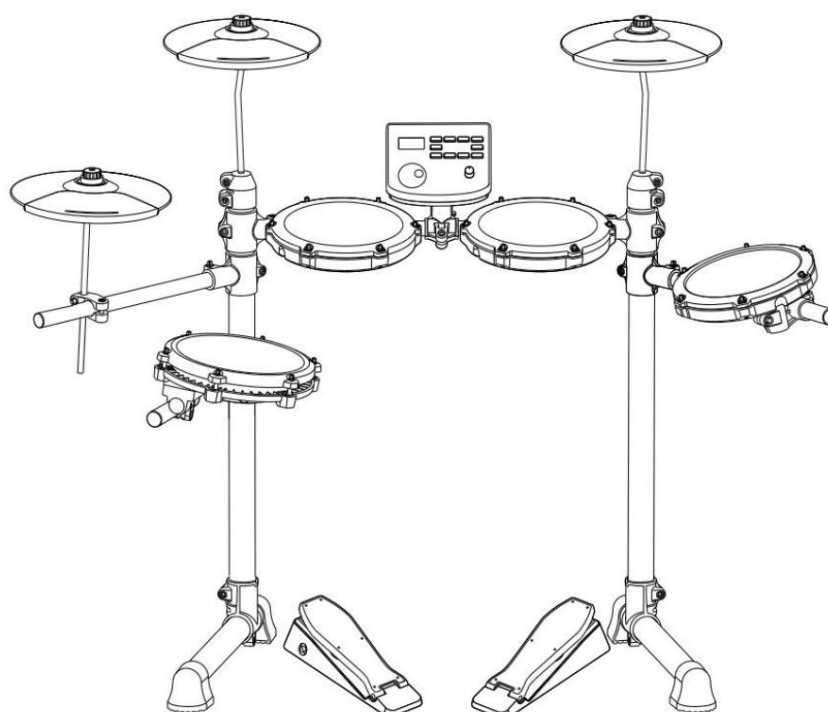

(L'image est à titre de référence seulement, veuillez vous référer à l'objet réel)

BESOIN D'AIDE? CONTACTEZ-NOUS!

Vous avez des questions sur les produits ? Besoin d'une assistance technique ? N'hésitez pas à contactez-

nous : support technique et certificat de garantie électronique

www.vevor.com/support

Il s'agit des instructions originales, veuillez lire attentivement toutes les instructions du manuel avant de l'utiliser. VEVOR se réserve une interprétation claire de notre manuel d'utilisation. L'apparence du produit dépend du produit que vous avez reçu. Veuillez nous pardonner que nous ne vous informerons plus s'il y a des mises à jour technologiques ou logicielles sur notre produit.



INTRODUCTION DES FONCTIONS

Merci d'avoir choisi notre batterie électronique. La batterie électronique élégante et délicate est la combinaison parfaite de la nouvelle technologie électronique moderne. •Avant d'utiliser ce produit, vous devez lire les instructions en détail.

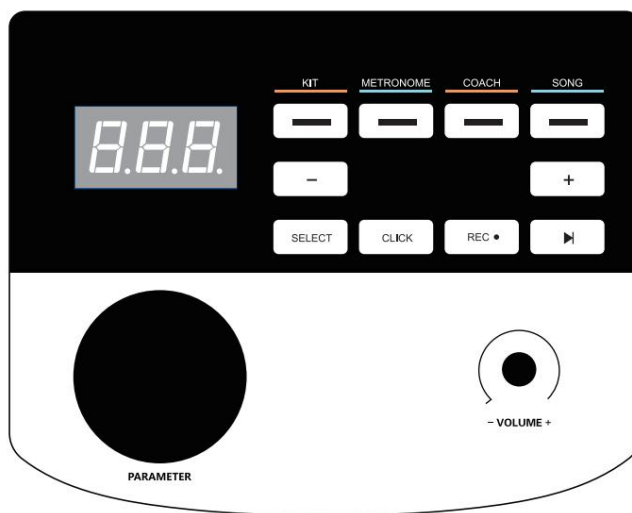

- 15 kits de batterie, 180 timbres
- 30 chansons
- prennent en charge le réglage des paramètres de sensibilité de chaque tambour •
- trois modes d'enseignement •
- contrôle de la vitesse : 30 ~ 250 battements/min
- métronome : 1 à 9 types •
- autres fonctions : stockage, réinitialisation et enregistrement des paramètres ; • affichage LED à trois chiffres ; • interface : alimentation CC, usbmidi, écouteurs, entrée audio, cymbale d'augmentation de sortie audio



REMARQUE!

- Ce produit est un instrument électro-acoustique. C'est normal qu'il y ait un peu de courant le son dans le haut-parleur ou les écouteurs après la mise sous tension.
Tenir à l'écart de « la radio, de la télévision, du récepteur d'antenne, du routeur, du réfrigérateur, de la télévision, du moteur et d'autres sources d'interférences électriques RF » pendant l'utilisation.



CONTENU

| | |
|--|-----|
| INTRODUCTION DES FONCTIONS | 1 |
| CONTENU | 2 |
| GUIDE D'INSTALLATION | 3 |
| VÉRIFIEZ LES ÉLÉMENTS CI-JOINTS | 3 |
| RACCORD DE TUYAU DE SUPPORT | 4 |
| SUPPORT DE MONTAGE | 4 |
| INSTALLATION DU BAC À FÛT | 5 |
| INSTALLATION DU MODULE SONORE | 5 |
| INSTALLER LES CYMBALES, LE MODULE DE SON, PLACER LES PÉDALES | 6 |
| INSÉRER LE CÂBLE DE CONNEXION DE LA PIÈCE DE FRAPPAGE | 7 |
| ILLUSTRATION DU PORT DU MODULE SON | 8 |
| CONNEXION DU CORDON D'ALIMENTATION | 8 |
| PORT MIDI USB | 8 |
| PORT DE SORTIE AUDIO | 8 |
| PORT D'ENTRÉE AUDIO | 8 |
| PORT POUR ÉCOUTEURS | 8 |
| GUIDE D'OPÉRATION | 9 |
| POUVOIR | 9 |
| SÉLECTION DU KIT DE BATTERIE | 9 |
| MÉTRONOME | 9 |
| FONCTION PRATIQUE | 9 |
| MODE ENTRAÎNEUR | 9 |
| CHANSON DE DÉMO | dix |
| PARAMÈTRES DU TAMBOUR | dix |
| FONCTION D'ENREGISTREMENT | dix |
| ENREGISTRER / RÉINITIALISER | dix |
| USB MIDI | dix |
| ANNEXE | 11 |
| TIMBRE DE TAMBOUR | 11 |
| KITS DE BATTERIE PRÉRÉGLÉS | 11 |
| KITS DE BATTERIE DÉFINIS PAR L'UTILISATEUR | 11 |
| CHANSON DE DÉMONSTRATION | 11 |
| ENTRETIEN DU PRODUIT | 12 |
| PRÉCAUTIONS DE SÉCURITÉ | 13 |



GUIDE D'INSTALLATION

REMARQUE!

- Veuillez suivre les instructions et lire attentivement les « précautions de sécurité » dans le manuel d'utilisation. avant d'utiliser .
- Ce produit doit être installé par un adulte, veuillez ne pas laisser un mineur l'installer indépendamment.

01

Vérifiez les éléments joints

- Après avoir ouvert le colis, veuillez vérifier immédiatement s'il contient tous les éléments. S'il en manque, veuillez contacter votre revendeur.



Module sonore



Support de module



Cymbale * 3



Tom (3 pièces)



Piège



Baguette de tambour



Pédale * 2



Câble de connexion des signaux



Adaptateur secteur

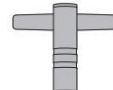

Clé de batterie



Bras de conduite/collision



Bras de charleston



GUIDE D'INSTALLATION

02

Raccord de tuyau de support

• Le support est situé dans un petit emballage individuel à l'intérieur de la boîte.

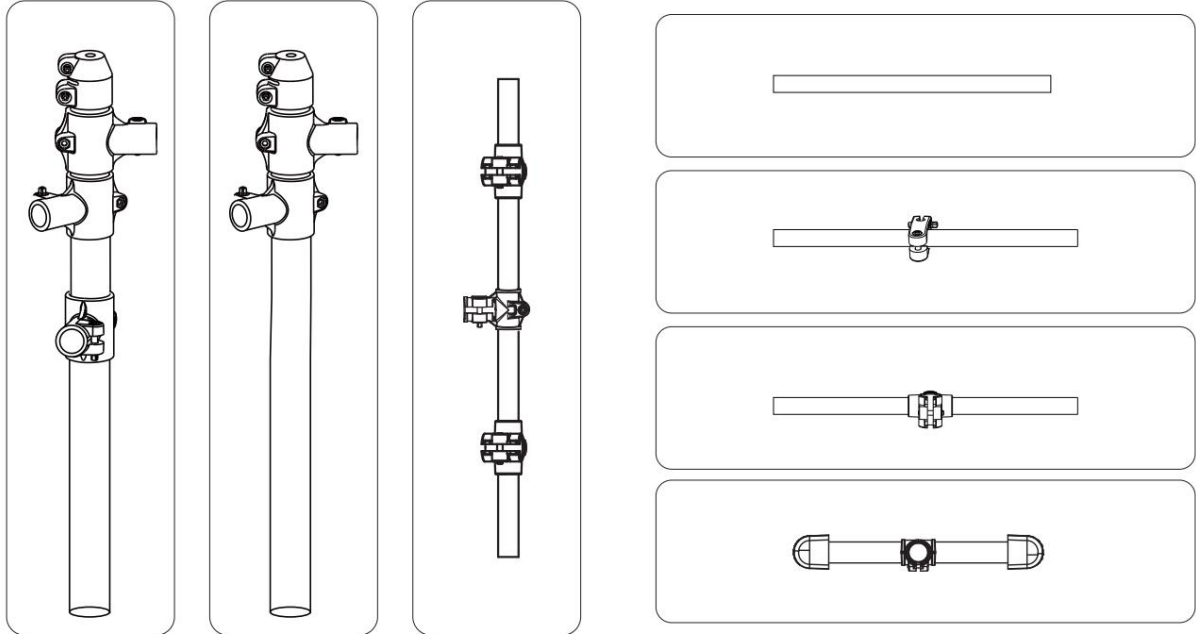

03

Support de montage

• Le support doit être installé en place et visser les vis à l'aide de la clé du tambour.

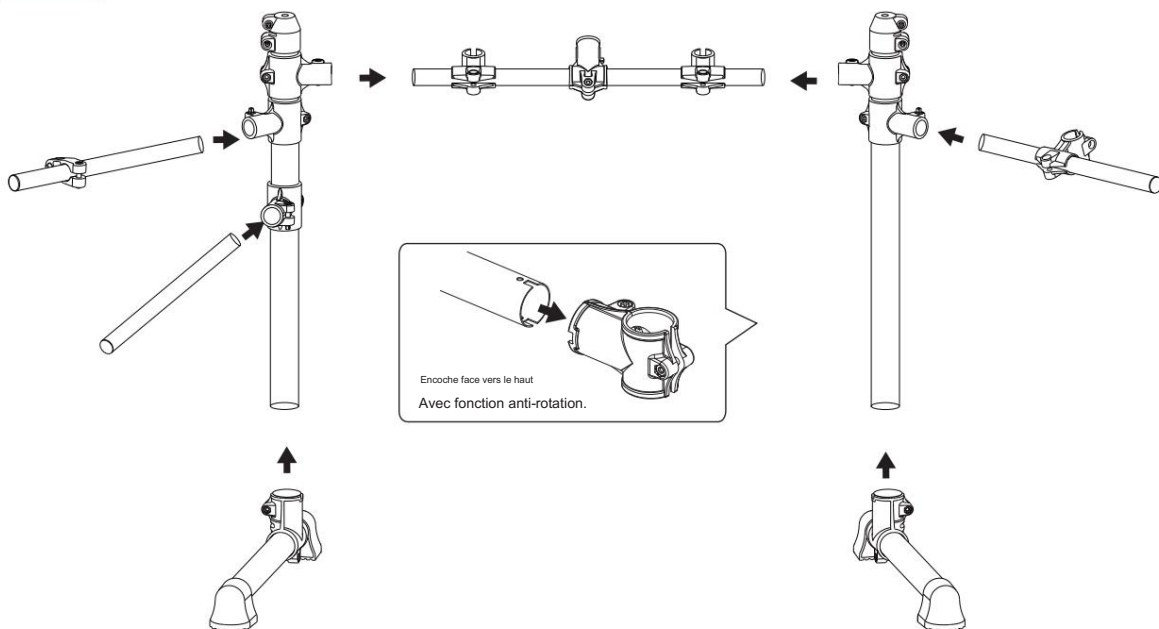



GUIDE D'INSTALLATION

04

Installation du bac à tambour

• Veuillez faire attention et ne pas vous pincer les doigts lors de l'installation.

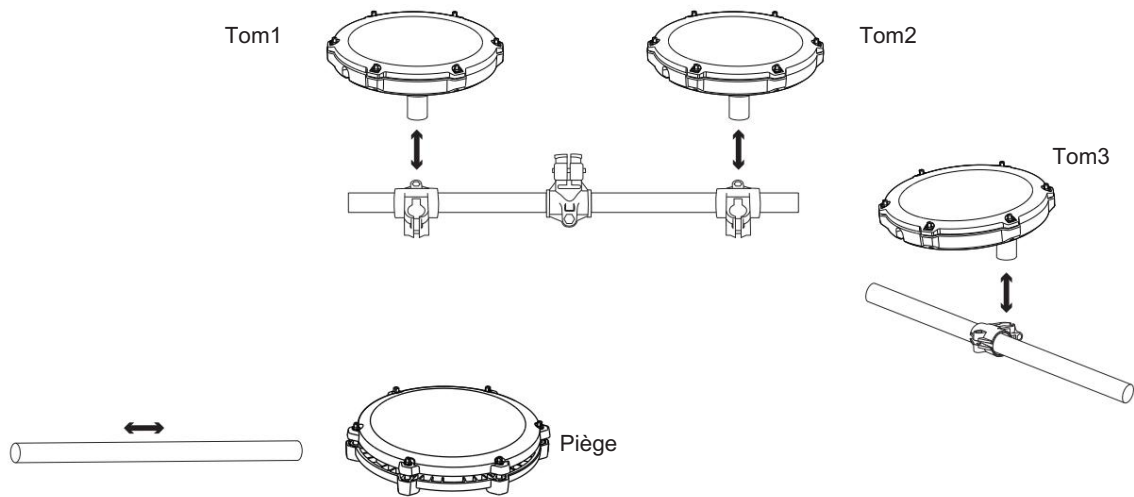

05

Installation du module de sons •

Assemblez le module de sons avec le support avant de le fixer au kit de batterie.

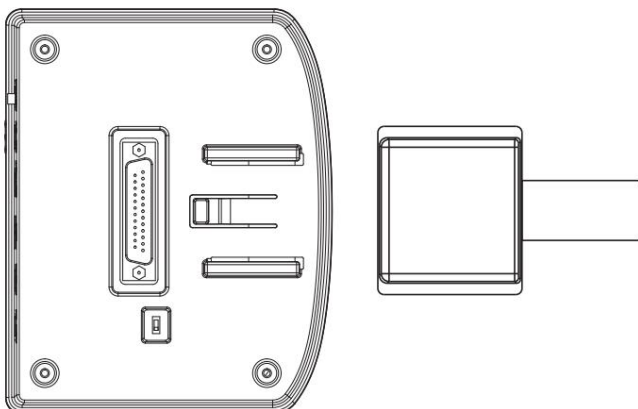

Insérez le support du boîtier principal contre la piste du module de son et vous entendrez le clic apparaître lorsque vous l'insérez vers le bas.



GUIDE D'INSTALLATION

06

Installer les cymbales, le module de son, placer les pédales

- Assurez-vous de ne pas trop serrer la cymbale, laissez-lui un peu d'espace pour qu'elle serpente de haut en bas.

Installez la cymbale et le module de son sur le support comme indiqué sur l'image

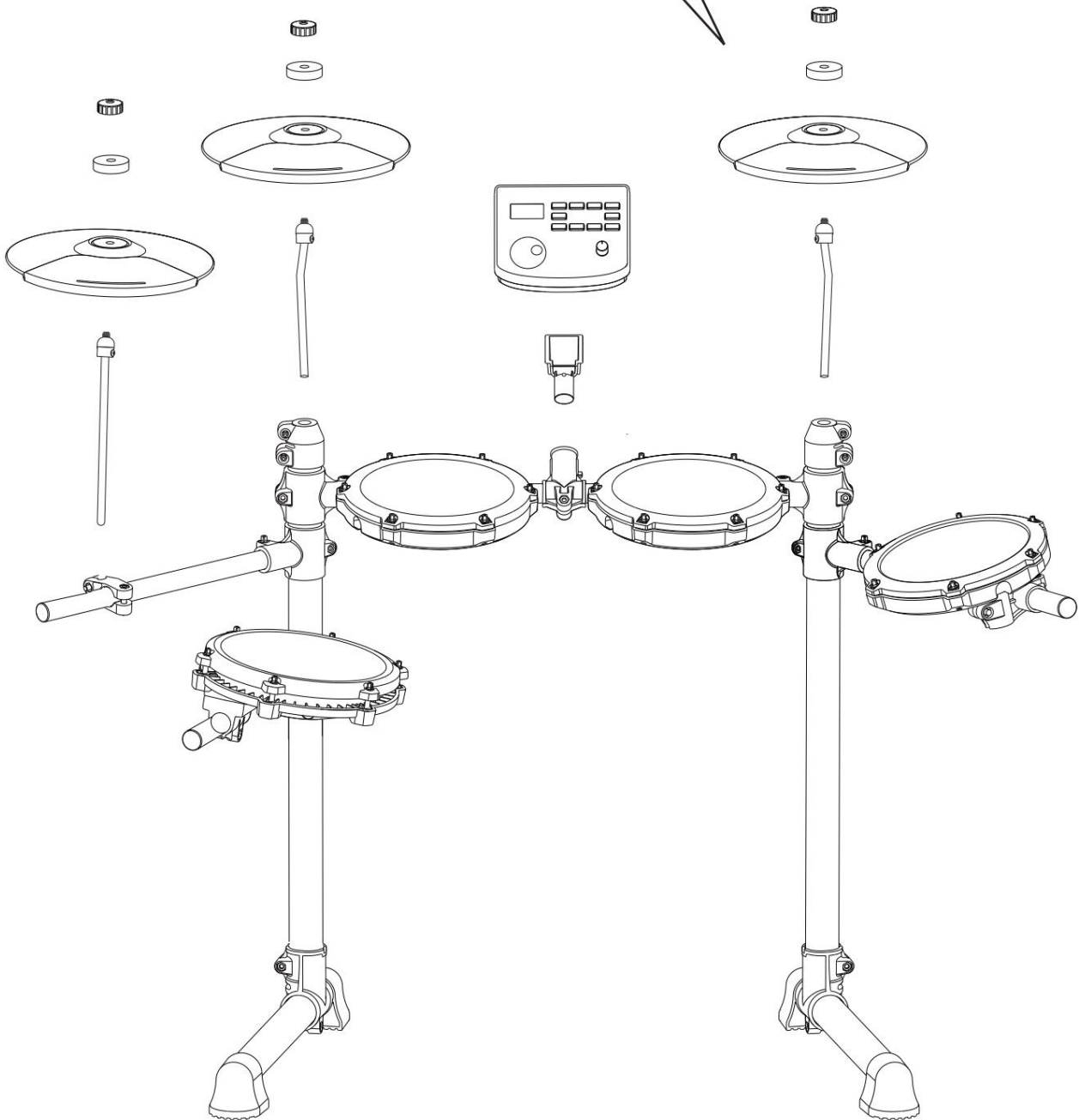
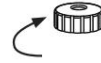



GUIDE D'INSTALLATION

07

Insérer le câble de connexion de la partie frappante

•Veuillez insérer le câble de connexion en place pour éviter un mauvais contact et insérez-le correctement comme indiqué dans le diagramme.

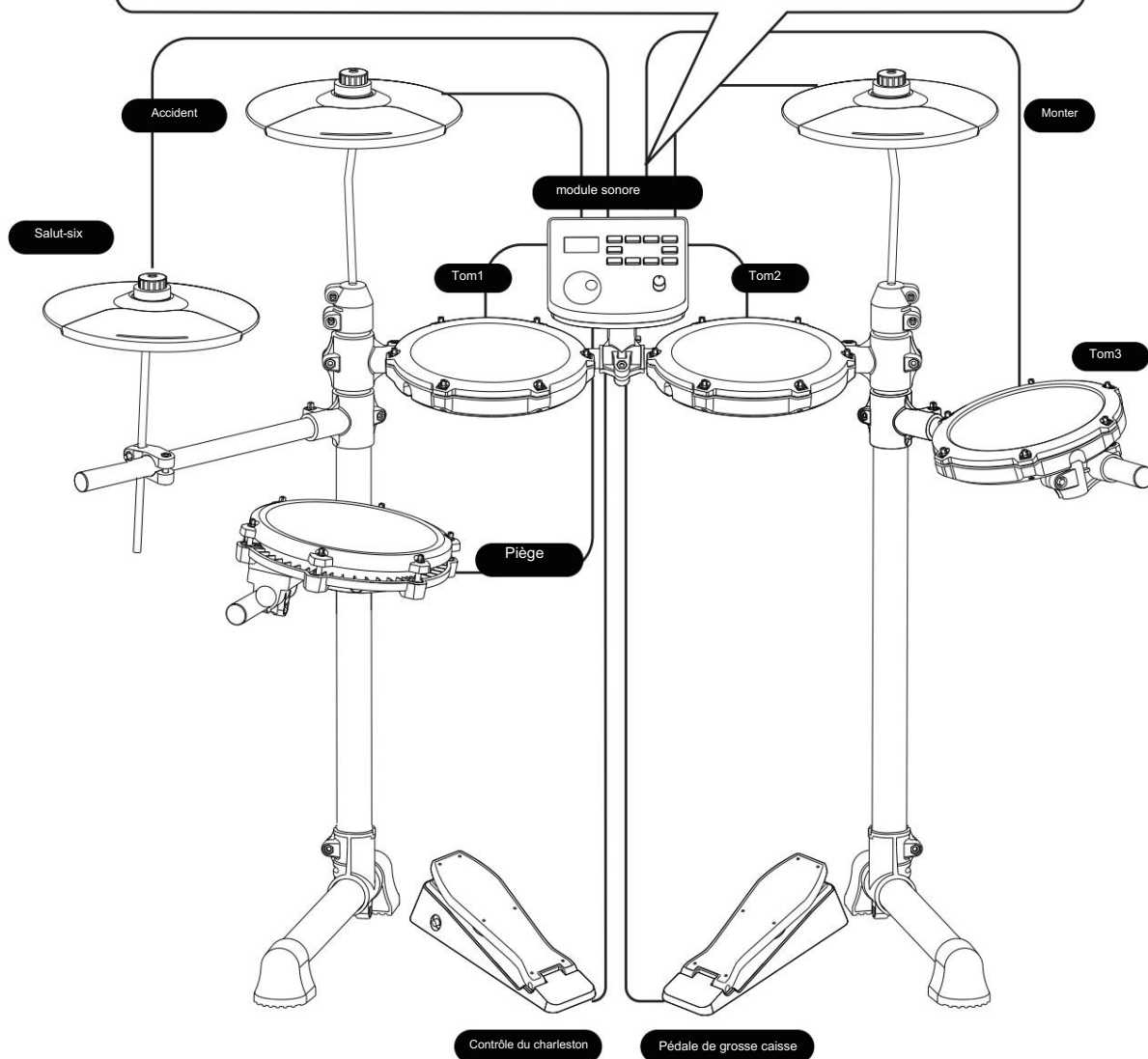
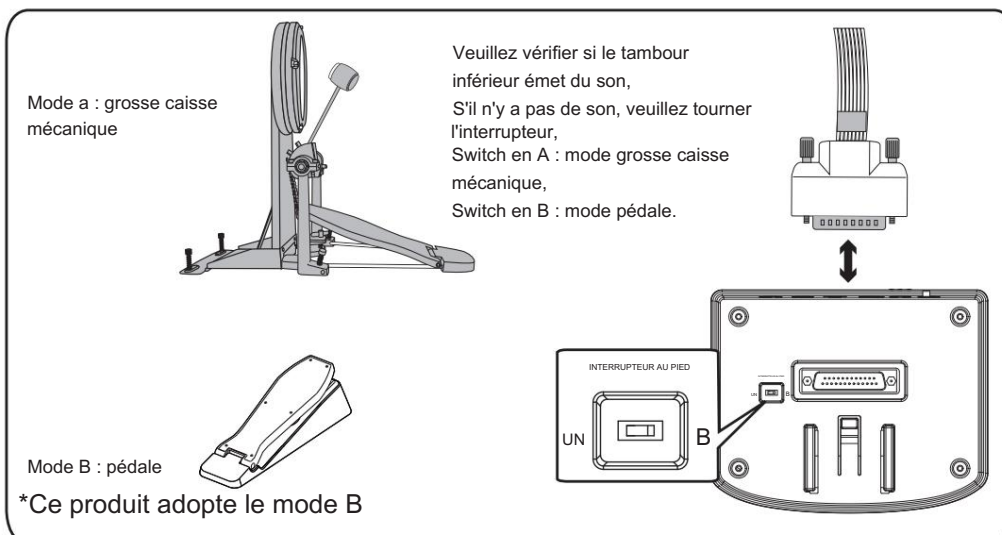
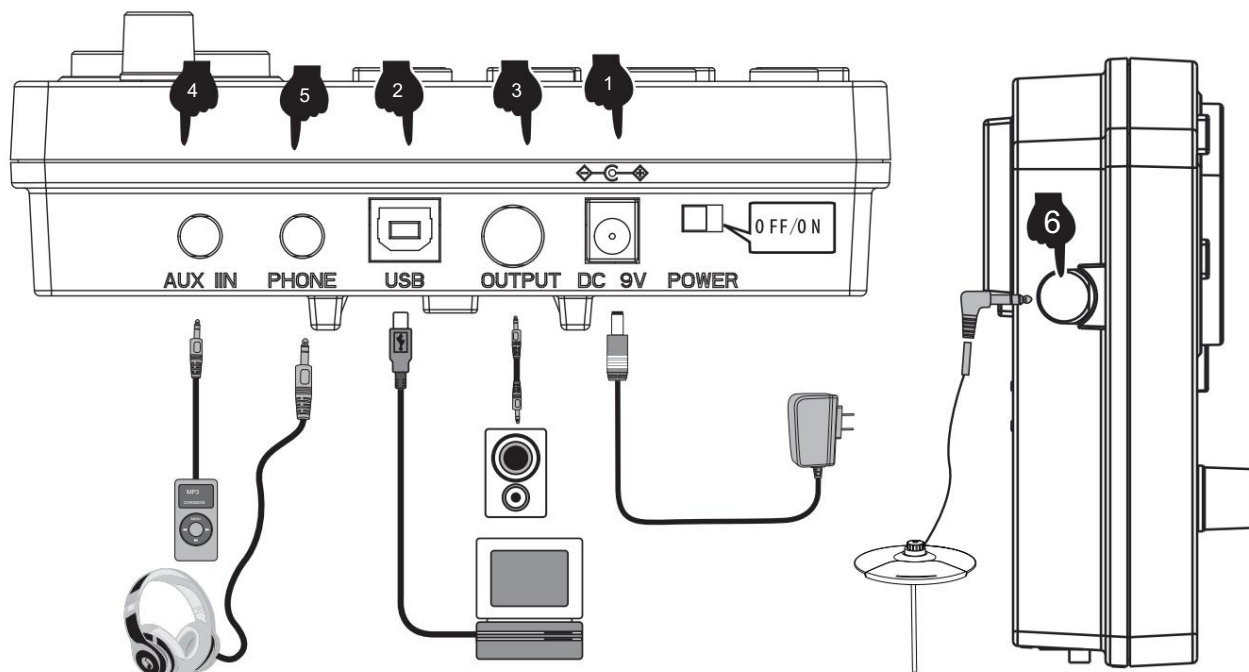



ILLUSTRATION DU PORT DU MODULE SON



1 CONNEXION DU CORDON D'ALIMENTATION

1. Lors de l'utilisation, connectez la borne d'alimentation selon le schéma, insérez la prise de courant du boîtier modulaire à une extrémité et une prise de courant domestique 100-240 V à l'autre extrémité. (Fig. 1)
2. Si vous n'utilisez pas ce produit pendant une longue période, veuillez débrancher la fiche d'alimentation et la conserver correctement.

2 ports USB-MIDI

L'utilisation de l'interface MIDI USB de batterie électronique peut interagir avec des appareils de musique avec MIDI.

1. Grâce au logiciel Musique préinstallé sur les ordinateurs et les téléphones mobiles, nous pouvons apprendre à jouer, composer de la musique, magasin et autres fonctions. (Fig.2)
2. Lorsqu'il est connecté à un ordinateur ou à un téléphone mobile, la sortie audio de l'appareil doit être connectée à l'audio prise d'entrée du module de son afin de synchroniser les effets sonores sur l'appareil. (Fig.5)

3 PORTS DE SORTIE AUDIO

Le port de sortie audio peut être connecté à un haut-parleur actif (haut-parleur de batterie électronique spécial) et à un grand équipement audio. (Fig.3)

4 PORTS D'ENTRÉE AUDIO

Le port d'entrée audio peut connecter le périphérique de lecture de source sonore au boîtier de module pour la lecture (comme MP3, téléphone portable et autre entrée de signal audio). (Fig.4)

5 PORTS ÉCOUTEURS

La connexion d'un casque surveille les détails des percussions et ne dérange pas les autres lorsque vous jouez sans connecter des haut-parleurs. (Fig.5)

6 AUGMENTER LE PORT

Ce port vous permet d'ajouter une cymbale pour une extension facile. (Figure 6)



GUIDE D'OPÉRATION

1 PUISSANCE

Insérez la fiche DC dans le port DC 9V sur le dessus du module de son. Faites glisser le commutateur POWER vers la droite (vu de l'avant) pour mettre le kit de batterie sous tension. Pour éteindre le kit de batterie, faites glisser le commutateur vers la gauche.

2 SÉLECTION DE KITS DE BATTERIE

Appuyez sur le bouton KIT pour afficher le kit de batterie actuel. Tournez la molette de paramètres ou utilisez les boutons <- /> pour sélectionner le kit de batterie souhaité. Vous avez le choix entre 15 kits de batterie - voir la liste des kits de batterie à la page 11.

3 MÉTRONOME

- Appuyez sur le bouton METRONOME pour accéder au mode métronome.
- L'écran affichera la valeur de la vitesse (vitesse par défaut de 120 BPM). Tournez la molette des paramètres ou utilisez le +/- boutons pour changer la vitesse du métronome. Appuyez sur le bouton CLICK pour démarrer le métronome.
- Appuyez sur le bouton SELECT en mode métronome et l'écran passera au paramètre métronome.

Interface de réglage. Vous pouvez appuyer sur les boutons +/- pour sélectionner le paramètre que vous souhaitez régler :

 - A. r (type de battement : 2,4,8,16)
 - B. b (numéro de temps : 01-09)
 - C. L (volume du métronome : 00 (arrêt) -31), puis tournez la molette de paramètres pour régler les paramètres.
- Une fois les paramètres ajustés, appuyez sur le bouton SELECT pour confirmer et quitter le paramètre interface. Puis
- Utilisez le bouton clic pour démarrer et arrêter le métronome comme vous le souhaitez.

4 FONCTION PRATIQUE

Le mode coach « coach » de ce produit peut aider à établir la vitesse, la précision et l'endurance, et aider à cultiver le Fonction de pratique d'un meilleur sens du rythme. Progressez sous la supervision du mode coach « coach » !

Appuyez sur le bouton « coach » pour accéder au mode coach. Dans ce mode, il existe trois modes d'entraînement. Sélectionnez la pratique mode via la molette de données ou le bouton < + > < - > .

- Mode d'exercice 1 : exercice de détection de battement C-1 : battez le tambour à une vitesse fixe pour entraîner la précision du coup.
- Mode d'entraînement 2 : mode de frappe silencieuse C-2 : le métronome sonnera une section et coupera une section pour entraîner le précision de frappe sans invite de métronome. Il s'agit d'une version avancée du mode pratique 1.
- Mode d'entraînement 3 : entraînement de frappe de vitesse C-3, le métronome changera automatiquement la vitesse, augmentera par rapport à la express le plus lent au plus rapide, puis réduire de l'express le plus lent à la vitesse la plus lente, de manière à pratiquer le endurance de frappe.

5 MODE ENTRAÎNEUR

- Le mode d'entraînement « coach » de ce produit peut aider à établir la vitesse, la précision et l'endurance. Appuyez sur le bouton COACH bouton pour accéder au mode coach. Dans ce mode, il existe trois modes d'entraînement. Utilisez la molette de paramètres pour sélectionner quel mode de pratique.
 - A. Mode d'exercice 1 : Exercice de détection de battement C-1 - battez le tambour à une vitesse fixe pour entraîner la précision du coup.
 - B. Mode d'entraînement 2 : mode de frappe silencieuse C-2 - le métronome sonnera une section et coupera une section pour s'entraîner quand il n'y a pas de battement.
 - C. Mode d'entraînement 3 : entraînement de frappe de vitesse C-3 - le métronome changera automatiquement la vitesse de la plus lente au plus rapide puis du plus rapide au plus lent.
- Une fois le mode coaching 3 choisi, appuyez sur le bouton CLIC. Les battements du métronome commenceront et vous pourrez jouer sur le tambour pour vous entraîner.
- Après quatre battements préliminaires, l'écran affichera :



GUIDE D'OPÉRATION

(trop lent)



(bien)



(trop vite)



4. Une fois que vous avez terminé le mode coaching, un score s'affichera de 0 à 100 évaluant l'exactitude de l'exercice.

Mode C-1 : appuyez sur le bouton SELECT pour accéder à l'interface de réglage des paramètres. Vous pouvez ajuster le nombre de pratique séances selon les besoins (01-32). Le nombre de séances à pratiquer détermine la durée de cet exercice.

Mode C-2 : appuyez sur le bouton SELECT pour accéder à l'interface de réglage des paramètres. Vous pouvez ajuster le nombre de pratique séances selon les besoins (04-32). Le nombre de séances à pratiquer détermine la durée de cet exercice.

Mode C-3 : appuyez sur le bouton SELECT pour accéder à l'interface de réglage des paramètres. Vous pouvez ajuster la vitesse à laquelle le BPM changements (01-09 BPM).

5. Appuyez à nouveau sur le bouton CLICK pour quitter le mode coach.

6 MORCEAUX DE DÉMO

1. Appuyez sur le bouton SONG pour accéder au mode démo, vous avez le choix entre 30 démos. L'écran affichera le numéro du morceau de démonstration actuel (01 -30).
2. Appuyez sur le bouton < > pour lancer la lecture des morceaux de démonstration. Pour arrêter la lecture, appuyez à nouveau sur la touche < >.
3. Tournez la molette de paramètres ou appuyez sur les boutons +/- pour sélectionner un morceau de démonstration.
4. Appuyez sur le bouton SELECT en mode chanson pour accéder à l'interface de réglage des paramètres de la chanson. Vous pouvez activer le son de la batterie on ou off en tournant la molette de paramètres (le son de batterie est activé par défaut).
5. Appuyez sur le bouton SELECT pour confirmer et quitter l'interface des paramètres.

7 PARAMÈTRES DU TAMBOUR

1. Appuyez sur le bouton KIT et l'écran affichera 01 (numéro du kit de batterie). Appuyez sur SELECT pour entrer dans le paramètre de batterie mode de réglage.
2. Appuyez sur le tambour que vous souhaitez régler, puis appuyez sur les boutons +/- pour sélectionner le paramètre à régler. Sensibilité S (01-06). Seuil de déclenchement t (01 - 32). Seuil de diaphonie c (01 -32) Déclenchement répété r (01-32) Force du tambour V (01-03). Volume du tambour L (00 - 31).
3. Modifiez les paramètres en tournant la molette des paramètres et appuyez longuement sur le bouton - pour enregistrer. L'écran avec affichage SAV pour indiquer que le réglage des paramètres a été enregistré avec succès.
4. Pour restaurer les paramètres du tambour aux paramètres d'usine, appuyez longuement sur le bouton + jusqu'à ce que l'écran affiche RES.PLEASE
REMARQUE : les paramètres des 3 toms ne peuvent pas être réglés individuellement.

8 FONCTION D'ENREGISTREMENT

1. Appuyez sur le bouton < REC > lorsque le voyant est dans les états « KIT » et « CLICK », et l'écran affiche le Mots « REC » dans l'état de clignotement respiratoire, entrant dans l'état de préparation d'enregistrement.
2. Appuyez sur n'importe quel tambour et le métronome sonne. À ce moment, l'écran affiche "---" en état de respiration clignotante et commence l'enregistrement.
3. Appuyez à nouveau sur la touche < REC > ou < PLAY >, l'enregistrement s'arrête et « A-1 » s'affiche à l'écran.
4. Appuyez sur < ▶ | > pour démarrer la lecture de l'enregistrement en cours, puis appuyez à nouveau pour arrêter la lecture.
5. Si vous entrez à nouveau dans l'état de préparation à l'enregistrement sans aucun coup, le "A-1" enregistré la dernière fois est lu.

9 ENREGISTRER / RÉINITIALISER

1. Pour enregistrer les paramètres, appuyez longuement sur le bouton <-> et l'écran affichera SAV.
2. Pour réinitialiser les paramètres, appuyez longuement sur le bouton <+> et l'écran affichera RES res.

10 USBMIDI

Pour utiliser la fonction MID des kits de batterie, branchez un câble de données USB-B (non inclus avec ce kit de batterie) dans l'unité de commande et Connectez-vous à un PC/smartphone.



APPENDIX

Timbre

| | | | |
|--|---------------------------------------|------------------------------|------------------------------------|
| Coup | 39 . Jante de caisse claire Jazz | 78 . Pop-Rock Tom3 | 116 . Crash2 populaire |
| 1 . Coup de pied funk | 40 . Jante de caisse claire Blues | 79 . Rocher Tom3 | 117 . Fusible Crash2 |
| 2 . Coup de pied original | 41 . Jante de caisse claire populaire | 80 . Séance Tom3 | 118 . Crash de dancehall2 |
| 3 . Coup de pied poprock | 42 . Jante de caisse claire Fuse | 81 . SpeedMétal Tom3 | 119 . Synthgaze Crash2 |
| 4 . Coup de pied rocheux | 43 . Jante de caisse claire Dancehall | 82 . ClassiqueDry Tom3 | 120 . Crash standard2 |
| 5 . Coup de pied de séance | 44 . Jante de caisse claire Synthgaze | 83 . Tom3 moderne | Monter |
| 6 . Coup de pied SpeedMetal | 45 . Jante de caisse claire standard | 84 . JazzTom3 | 121 . Tour funk |
| 7 . ClassiqueDry Kick | À M | 85 . BluesTom3 | 122 . Balade originale |
| 8ème . Coup de pied moderne | 46 . Funk Tom1 | 86 . Populaire Tom3 | 123 . Balade pop-rock |
| 9 . Coup de pied de jazz | 47 . Tom1 original | 87 . Fusible Tom3 | 124 . Balade rocheuse |
| dix . Coup de pied de blues | 48 . Pop-Rock Tom1 | 88 . Dancehall Tom3 | 125 . Balade de séance |
| 11 . Coup de pied populaire | 49 . Rocher Tom1 | 89 . Synthgaze Tom3 | 126 . Tour SpeedMetal |
| 12 . Coup de pied de fusible | 50 . Séance Tom1 | 90 . Tome 3 standard | 127 . ClassiqueDry Ride |
| 13 . Coup de pied dancehall | 51 . SpeedMétal Tom1 | Accident | 128 . Balade moderne |
| 14 . Coup de pied synthétisé | 52 . ClassiqueDry Tom1 | 91 . Funk Crash1 | 129 . Balade Jazz |
| 15 . Coup de pied standard | 53 . Tom1 moderne | 92 . Crash original1 | 130 . Balade en Blues |
| Piège | 54 . Jazz Tom1 | 93 . Crash pop-rock1 | 131 . Balade populaire |
| 16 . Caisse claire funk | 55 . Bleus Tom1 | 94 . Crash de roche1 | 132 . Tour de fusible |
| 17 . Caisse claire originale | 56 . Populaire Tom1 | 95 . Crash de session1 | 133 . Balade dansante |
| 18 . Caisse Claire Pop Rock | 57 . Fusible Tom1 | 96 . Crash de métal rapide1 | 134 . Tour de synthgaze |
| 19 . Caisse claire à roche | 58 . Salle de danse Tom1 | 97 . ClassiqueDry Crash1 | 135 . Balade standard |
| 20 . Piège à vision | 59 . Synthgaze Tom1 | 98 . Crash moderne1 | Salut chapeau |
| 21 . Caisse Claire SpeedMetal | 60 . Tome standard1 | 99 . Crash de Jazz1 | 136 . Funk charleston ouvert |
| 22 . Caisse Claire ClassiqueDry | 61 . Funk Tom2 | 100 . Blues-Crash1 | 137 . Charleston original ouvert |
| 23 . Caisse claire moderne | 62 . Tom2 original | 101 . Crash populaire1 | 138 . Pop Rock Charleston Ouvert |
| 24 . Caisse Claire Jazz | 63 . Pop-Rock Tom2 | 102 . Crash de fusible1 | 139 . Rock Charleston Ouvert |
| 25 . Caisse claire de blues | 64 . Rocher Tom2 | 103 . Crash de dancehall1 | 140 . Seesion Charleston Ouvert |
| 26 . Caisse claire populaire | 65 . Séance Tom2 | 104 . Synthgaze Crash1 | 141 . Charleston SpeedMetal ouvert |
| 27 . Fusible Caisse Claire | 66 . SpeedMétal Tom2 | 105 . Crash standard1 | 142 . ClassicDry Charleston Ouvert |
| 28 . Caisse Claire Dancehall | 67 . ClassiqueDry Tom2 | 106 . Funk Crash2 | 143 . Charleston moderne ouvert |
| 29 . Caisse claire Synthgaze | 68 . Tom2 moderne | 107 . Crash2 d'origine | 144 . Jazz charleston ouvert |
| 30 . Caisse claire standard | 69 . JazzTom2 | 108 . Poprock Crash2 | 145 . Charleston Blues ouvert |
| 31 . Jante de caisse claire Funk | 70 . BluesTom2 | 109 . Crash de roche2 | 146 . Charleston populaire ouvert |
| 32 . Jante de caisse claire originale | 71 . Populaire Tom2 | 110 . Crash de session2 | 147 . Fuse Hi-Hat ouvert |
| 33 . Comptine Pop Rock Snare | 72 . Fusible Tom2 | 111 . Crash de métal rapide2 | 148 . Charleston Dancehall ouvert |
| 34 . Jante de caisse claire Rock | 73 . Dancehall Tom2 | 112 . ClassiqueDry Crash2 | 149 . Synthgaze Charleston Ouvert |
| 35 . Jante de caisse claire Seesion | 74 . Synthgaze Tom2 | 113 . Crash moderne2 | 150 . Charleston standard ouvert |
| 36 . Jante de caisse claire SpeedMetal | 75 . Tome 2 standard | 114 . JazzCrash2 | 151 . Funk Charleston Fermer |
| 37 . Jante de caisse claire ClassicDry | 76 . Funk Tom3 | 115 . BluesCrash2 | 152 . Hi-Hat original |
| 38 . Jante de caisse claire moderne | 77 . Tom3 original | | |

**APPENDIX**

| | | |
|------------------------------------|---------------------------------------|--------------------------------------|
| 153 . Charleston Poprock Fermer | 163 . Charleston Dancehall Fermer | 173 . Pédale de charleston moderne |
| 154 . Charleston Rock Fermer | 164 . Synthgaze Charleston Fermer | 174 . Pédale de charleston Jazz |
| 155 . Seesion Charleston Fermer | 165 . Charleston standard | 175 . Pédale de Charleston Blues |
| 156 . Charleston SpeedMetal Fermer | 166 . Pédale de charleston Funk | 176 . Pédale de charleston populaire |
| 157 . ClassicDry Charleston Fermer | 167 . Pédale de charleston originale | 177 . Fuse Pédale de Charleston |
| 158 . Charleston moderne | 168 . Pédale de charleston Pop Rock | 178 . Pédale de charleston Dancehall |
| 159 . Charleston Jazz Fermer | 169 . Pédale de charleston Rock | 179 . Synthgaze Pédale de Charleston |
| 160 . Charleston Blues Fermer | 170 . Pédale de charleston Seesion | 180 . Pédale de charleston standard |
| 161 . Charleston populaire | 171 . Pédale de charleston SpeedMetal | |
| 162 . Fuse Charleston Fermer | 172 . Pédale de charleston ClassicDry | |

Drum combination timbre

Kit de batterie utilisateur

| | | | | |
|-------------|---------------|---------------|------------|--------------|
| 01 Funk | 04 Rock | 07 ClassicDry | 10 Blues | 13 Dancehall |
| 02 Original | 05 Seesion | 08 Modern | 11 Popular | 14 Synthgaze |
| 03 Poprock | 06 SpeedMetal | 09 Jazz | 12 Fuse | 15 Standard |

Chanson de démonstration

| | | | | | | | |
|-------------|-------------|-------------|-------------|-------------|-------------|-------------|-------------|
| Chanson 001 | Chanson 005 | Chanson 009 | Chanson 013 | Chanson 017 | Chanson 021 | Chanson 025 | Chanson 029 |
| Chanson 002 | Chanson 006 | Chanson 010 | Chanson 014 | Chanson 018 | Chanson 022 | Chanson 026 | Chanson 030 |
| Chanson 003 | Chanson 007 | Chanson 011 | Chanson 015 | Chanson 019 | Chanson 023 | Chanson 027 | |
| Chanson 004 | Chanson 008 | Chanson 012 | Chanson 016 | Chanson 020 | Chanson 024 | Chanson 028 | |



PRODUCT MAINTENANCE

Careful maintenance and protection of the product, to extend the service life of the product, reduce the fault has a very important role.

1 AVOID HEATING, DAMPNES OR DIRECT SUNLIGHT

Do not over expose the product to direct sunlight, or place it near air conditioning or extremely hot place.

2 DO NOT USE NEAR THE TV OR RADIO

This product may cause video or audio interference to the reception of TV and radio. If this happens, the product should be removed from the TV or radio.

3 NO DILUENTS OR SIMILAR CHEMICALS SHOULD BE USED FOR CLEANING

Clean the product with a soft cloth wetted with weak water solution and neutral detergent. Soak the cloth in a solution and wring it dry until it approaches drying.

4 DO NOT SHAKE, AVOID COLLISION

When moving, the product should be handled carefully and lightly. Violent vibration and collision are strictly prohibited in order to avoid damage to the shell or internal electronic components.



SAFETY PRECAUTIONS

POWER SUPPLY

This product can be powered by standard indoor wall sockets. Please only use the power cord specified in this product. When not in use, please turn off the power supply. When not in use for a long time, pull out the power cord and keep it properly.

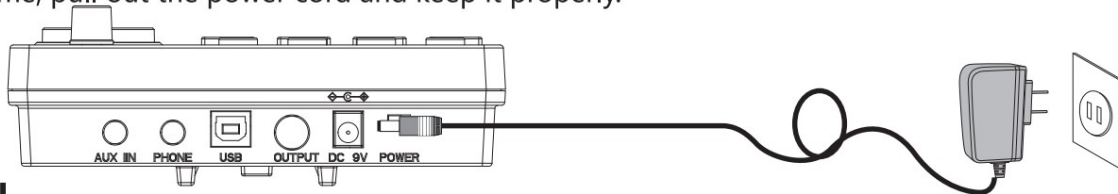

SIGN

To ensure that you use this product safely and correctly, to prevent harm to users and others and financial damage, this manual and products are marked with a series of safety signs. The various signs and their meanings are as follows:

WARNING

This sign indicates that there is a potential risk of death or serious injury if this mark is ignored and the product is mishandled.

BE CAREFUL

This sign indicates that there is a potential danger of injury to personnel or other financial damage if this sign is ignored and the product is operated incorrectly.

EXAMPLE OF LOGO



This triangle sign (Δ) indicates what users should pay attention to. (The left example is careful shocks)



A circular sign (\ominus) with an oblique line indicates prohibitions. The icons in or beside the logo indicate the contents specifically prohibited. (The example on the left is no disassembly)



The round black bottom sign (\odot) indicates what must be observed. The diagrams in this sign indicate the contents of the specific matters that must be observed. (The example on the left is that the power plug must be pulled out of the socket)



SAFETY PRECAUTIONS

WARNING

Smoke, odor, overheating

When the product smokes, smells or overheats, there is a danger of fire and electric shock when it is used continually. In case of the above situation, the following operations should be performed immediately:

1. Turn off the power supply.
2. Pull the plug out of the power outlet.
3. Contact your dealer.

Power cord

1. The improper use of power cord may cause fire and electric shock. The following precautions must be observed:

- The special power cord designated for this product must be used.
- The AC power supply with output voltage within the rated voltage range for household use must be used.
- Do not overload power sockets and extension lines.



2. The improper treatment of power line will lead to its damage or breakage, which will cause fire and electric shock hazards. The following precautions must be observed:

- Do not place or heat heavy objects on power lines.
- Do not attempt to alter or bend the power cord too much.
- Do not twist or pull the power cord.
- If the power cord or plug is damaged, please replace the same type of power cord.



3. Do not touch the power cord and plug with wet hands, otherwise there is a danger of electric shock.



4. Please use the power cord where the water will not splash. Water is in danger of causing fire and electric shock.



5. Never place vases or any other container containing water on this product. Water is dangerous of causing fire and electric shock.



6. Do not allow minors to unplug and touch power lines or connection boards. Minors have no common sense of electricity safety, which may cause electric shock.



BE CAREFUL

The improper use of power cord may cause fire and electric shock. The following precautions must be observed:

- Never put the power cord near the oven or other heat source.
- Do not pull the cable when pulling out of the power socket. The main body of the plug must be grasped.
- The power cord plug must be inserted in the socket to the end.
- Make sure the power supply is off before connecting or disconnecting it.
- When thunderstorms occur or before traveling or other long-term departure, disconnect the power cord from the wall outlet.
- At least once a year, remove the power cord from the wall outlet and clean the dust accumulated around the plug.



Do not burn this product

Do not put this product in the fire, otherwise it will lead to product combustion and explosion of internal electronic components, which will cause fire and personnel injury.



Water and foreign bodies

Water, other liquids and (metal sheets, etc.) entering this product are in danger of causing fire and electric shock. In case of the above situation, the following operations shall be performed immediately:

1. Turn off the power supply.
2. If you are using a power cord for power supply, unplug it from the wall outlet.
3. Contact your distributor.



Disassembly and transformation

Do not disassemble or transform the product in any way, otherwise there is a risk of electric shock, scald or other personal injury. All internal inspection, adjustment and maintenance operations should be entrusted to your distributor.





SAFETY PRECAUTIONS

Falling or colliding

If the product falls or is damaged by strong impact, it will be in danger of causing fire and electric shock. In case of the above situation, the following operations shall be performed immediately:

1. Turn off the power supply.
2. If you are using a power cord for power supply, you need to unplug it from the wall outlet.
3. Contact your distributor.



Plastic bag

Do not let anyone put plastic bags for this product on his head or in his mouth. Otherwise, there is a risk of asphyxia. Families with young children should pay special attention to it.



Keep a distance from the product and the bracket

Climbing the bracket is dangerous of overturning or damage. Families with young children should pay special attention to it.



Put

Avoid placing the product on an uneven surface or any other unstable place. Otherwise, it will cause the product to fall down, which will lead to the risk of injury.



Product Mobility

Before moving this product, you must unplug the power cord plug from the wall outlet and pull out all other cables and connecting wires. Otherwise, it will lead to damage of power or connection wires, resulting in fire and electric shock.



clean

Before cleaning this product, you must unplug the power cord plug from the wall outlet, otherwise there is a risk of fire and electric shock.



Jack

The socket of this product can only be connected to the designated equipment and devices. Connecting non-designated equipment or devices is dangerous of causing fire and electric shock.



Location selection

It should be avoided to place the product in the following places, otherwise there is a risk of fire and electric shock.

- High temperature or dusty places.
- Kitchen or other places with lampblack.
- Where the product is exposed to direct sunlight, or any other place where the product will produce high temperature.



Volume

Don't play music long and loud. Pay special attention when using headphones. Excessive volume can damage your hearing.



Heavy



Do not place heavy objects on this product. Otherwise, the top of the product will be overweight, causing the product to overturn or drop objects on it, which will lead to the risk of injury.



Correct assembly of scaffolds

The incorrect assembly of the bracket may overturn, causing the product to fall off and posing a risk of injury to personnel. Therefore, it must be assembled according to the instructions in the attached installation guide to ensure that the product is properly mounted on its bracket.



| | |
|--|--|
|  | <p>Avertissement : Pour réduire le risque de blessure, l'utilisateur doit lire attentivement le manuel d'instructions.</p> |
|  | <p>Cet appareil est conforme à la partie 15 des règles FCC. Son fonctionnement est soumis aux deux conditions suivantes : (1) Cet appareil ne doit pas provoquer d'interférences nuisibles et (2) cet appareil doit accepter toute interférence reçue, y compris les interférences susceptibles de provoquer un fonctionnement indésirable.</p> |
|  | <p>Ce produit est soumis aux dispositions de la directive européenne 2012/19/CE. Le symbole représentant une poubelle barrée indique que le produit nécessite une collecte sélective des déchets dans l'Union européenne. Ceci s'applique au produit et à tous les accessoires marqués de ce symbole. Les produits marqués comme tels ne peuvent pas être jetés avec les ordures ménagères normales, mais doivent être déposés dans un point de collecte pour le recyclage des appareils électriques et électroniques.</p> |

Fabricant : Shanghaimuxinmuyeyouxiangongsi Adresse :

Shuangchenglu 803nong11hao1602A-1609shi, baoshanqu, shanghai 200000 CN.

Importé en Australie : SIHAO PTY LTD, 1 ROKEVA STREETESTWOOD NSW
2122 Australie

Importé aux États-Unis : Sanven Technology Ltd., Suite 250, 9166 Anaheim Place, Rancho
Cucamonga, CA 91730

| | |
|-----------------|--|
| REPRÉSENTANT CE | |
|-----------------|--|

E-CrossStu GmbH
Mainzer Landstr.69, 60329 Francfort-sur-le-Main.

| | |
|-----------------------------|--|
| REPRÉSENTANT DU ROYAUME-UNI | |
|-----------------------------|--|

YH CONSULTING LIMITÉE.
C/O YH Consulting Limited Bureau 147, Centurion House,
London Road, Staines-upon-Thames, Surrey, TW18 4AX

VEVOR[®]

TOUGH TOOLS, HALF PRICE

Assistance technique et certificat de garantie
électronique www.vevor.com/support

VEVOR[®]

TOUGH TOOLS, HALF PRICE

Technischer Support und E-Garantie-Zertifikat
www.vevor.com/support

ELEKTRONISCHES SCHLAGZEUG

BENUTZERHANDBUCH

MODELL: MD200C

Wir sind weiterhin bestrebt, Ihnen Werkzeuge zu wettbewerbsfähigen Preisen anzubieten. „Sparen Sie die Hälfte“, „Halber Preis“ oder andere ähnliche Ausdrücke, die wir verwenden, stellen lediglich eine Schätzung der Ersparnis dar, die Sie beim Kauf bestimmter Werkzeuge bei uns im Vergleich zu den großen Topmarken erzielen können, und decken nicht unbedingt alle von uns angebotenen Werkzeugkategorien ab. Wir möchten Sie freundlich daran erinnern, bei der Bestellung bei uns sorgfältig zu prüfen, ob Sie im Vergleich zu den großen Topmarken tatsächlich die Hälfte sparen.

VEVOR[®]
TOUGH TOOLS, HALF PRICE

ELEKTRONISCHES SCHLAGZEUG

MODELL: MD200C

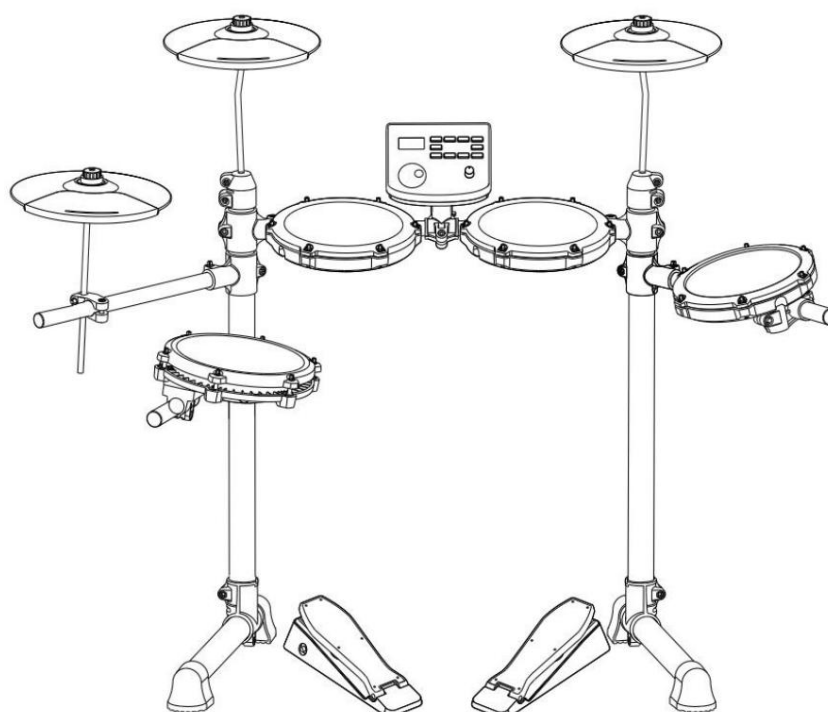

(Das Bild dient nur als Referenz, bitte beziehen Sie sich auf das tatsächliche Objekt)

Brauchen Sie Hilfe? Kontaktieren Sie uns!

Haben Sie Fragen zu unseren Produkten? Benötigen Sie technische Unterstützung?
Kontaktieren

Sie uns: **Technischer Support und E-Garantie-Zertifikat**
www.vevor.com/support

Dies ist die Originalanleitung. Bitte lesen Sie alle Anweisungen sorgfältig durch, bevor Sie das Gerät in Betrieb nehmen. VEVOR behält sich eine klare Auslegung unserer Bedienungsanleitung vor. Das Erscheinungsbild des Produkts richtet sich nach dem Produkt, das Sie erhalten haben. Bitte verzeihen Sie uns, dass wir Sie nicht erneut informieren, wenn es Technologie- oder Software-Updates für unser Produkt gibt.



FUNKTION EINFÜHRUNG

Vielen Dank, dass Sie sich für unser elektronisches Schlagzeug entschieden haben. Das elegante und filigrane elektronische Schlagzeug ist die perfekte Kombination aus moderner neuer elektronischer Technologie. •Bevor Sie dieses Produkt verwenden, müssen Sie die Anweisungen ausführlich lesen.

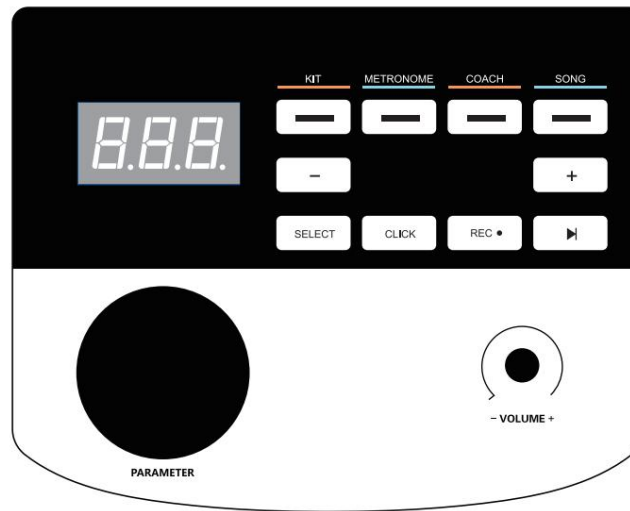

- 15 Drum-Kits, 180 Klangfarben

- 30 Lieder •

unterstützt die Anpassung der Empfindlichkeitsparameter jeder Trommel • drei Lehrmodi •

Geschwindigkeitskontrolle: 30 ~ 250 Schläge / min

- Metronom: 1-9 Typen •

Weitere Funktionen: Parameterspeicherung, Zurücksetzen und Aufzeichnen; • Dreistellige

LED-Anzeige; • Schnittstelle: Stromversorgung DC, USB-MIDI, Kopfhörer, Audioeingang, Audioausgang zur Beckenverstärkung

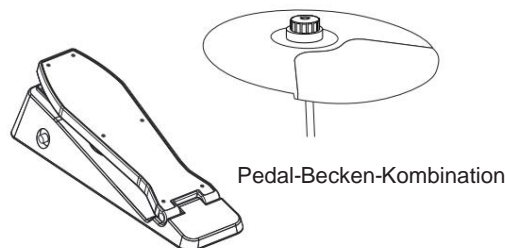

ANMERKUNG!

- Bei diesem Produkt handelt es sich um ein elektroakustisches Instrument. Es ist normal, dass ein geringer Strom fließt. Ton im Lautsprecher oder Kopfhörer nach dem Einschalten.

Halten Sie das Gerät während der Verwendung von „Radio, Fernseher, Antennenempfänger, Router, Kühlschrank, Fernsehgerät, Motor und anderen elektrischen HF-Störquellen“ fern.



INHALT

| | |
|--|-----------|
| FUNKTION EINFÜHRUNG | 1 |
| INHALT | 2 |
| INSTALLATIONSANLEITUNG | 3 |
| ÜBERPRÜFEN SIE DIE BEILIEGENDEN ELEMENTE | 3 |
| STANDROHRVERBINDUNG | 4 |
| MONTAGESTÄNDER | 4 |
| INSTALLATION DER TROMMELWANNE | 5 |
| EINBAU DES SOUNDMODULS | 5 |
| BECKEN, SOUNDMODUL INSTALLIEREN, PEDALE PLATZIEREN | 6 |
| ANSCHLUSSKABEL DES SCHLAGTEILS EINSETZEN | 7 |
| ABBILDUNG DES SOUNDMODUL-PORTS | 8 |
| ANSCHLUSS DES NETZKABELS | 8 |
| USB-MIDI-ANSCHLUSS | 8 |
| AUDIO-AUSGANGSANSCHLUSS | 8 |
| AUDIO-EINGANGSANSCHLUSS | 8 |
| KOPFHÖRERANSCHLUSS | 8 |
| BEDIENUNGSANLEITUNG | 9 |
| LEISTUNG | 9 |
| SCHLAGZEUGAUSWAHL | 9 |
| METRONOM | 9 |
| PRAXISFUNKTION | 9 |
| COACH-MODUS | 9 |
| DEMO-SONG | 10 |
| TROMMELPARAMETER | 10 |
| AUFNAHMEFUNKTION | 10 |
| SPEICHERN / ZURÜCKSETZEN | 10 |
| USBMIDI | 10 |
| ANHANG | 11 |
| TROMMELKLANG | 11 |
| VOREINGESTELLTE DRUM-KITS | 11 |
| BENUTZERDEFINIERT DRUM-KITS | 11 |
| DEMONSTRATIONS LIED | 11 |
| PRODUKTWARTUNG | 12 |
| SICHERHEITSVORKEHRUNGEN | 13 |



INSTALLATIONSANLEITUNG

ANMERKUNG!

- Bitte befolgen Sie die Anweisungen und lesen Sie die „Sicherheitshinweise“ im Benutzerhandbuch sorgfältig durch vor Gebrauch .
- Dieses Produkt muss von einem Erwachsenen installiert werden. Überlassen Sie die Installation bitte nicht Minderjährigen.

01

Überprüfen Sie die beigelegten Elemente

- Bitte prüfen Sie nach dem Öffnen der Verpackung umgehend, ob diese vollständig ist. Sollten welche fehlen, wenden Sie sich bitte an Ihren Händler.



Soundmodul



Modulhalterung



Becken*3



Tom (3 Stück)



Schlinge



Trommelstock



Pedale * 2



Signalanschlusskabel



Netzteil

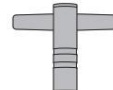

Stimm Schlüssel



Ride/Crash-Arm



Hi-Hat-Arm



INSTALLATIONSANLEITUNG

02

Standrohrverschraubung

• Der Ständer befindet sich in einer kleinen Einzelverpackung im Inneren der Box.

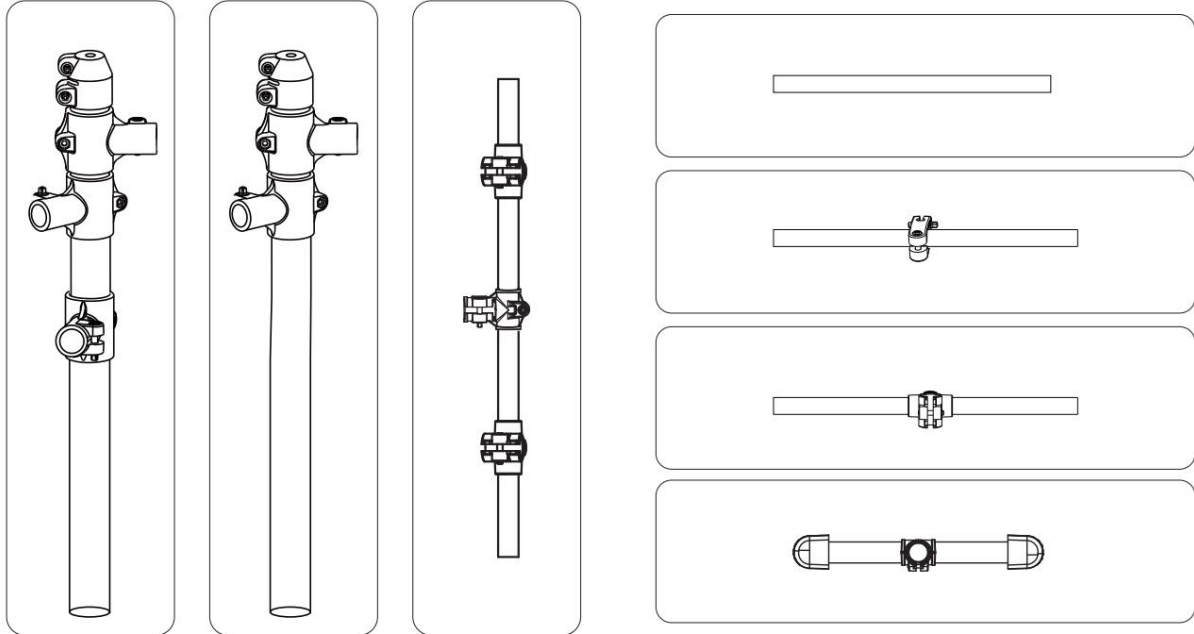

Montageständer

03 • Der Ständer muss an Ort und Stelle installiert und die Schrauben mit dem Stimmschlüssel festgezogen werden.

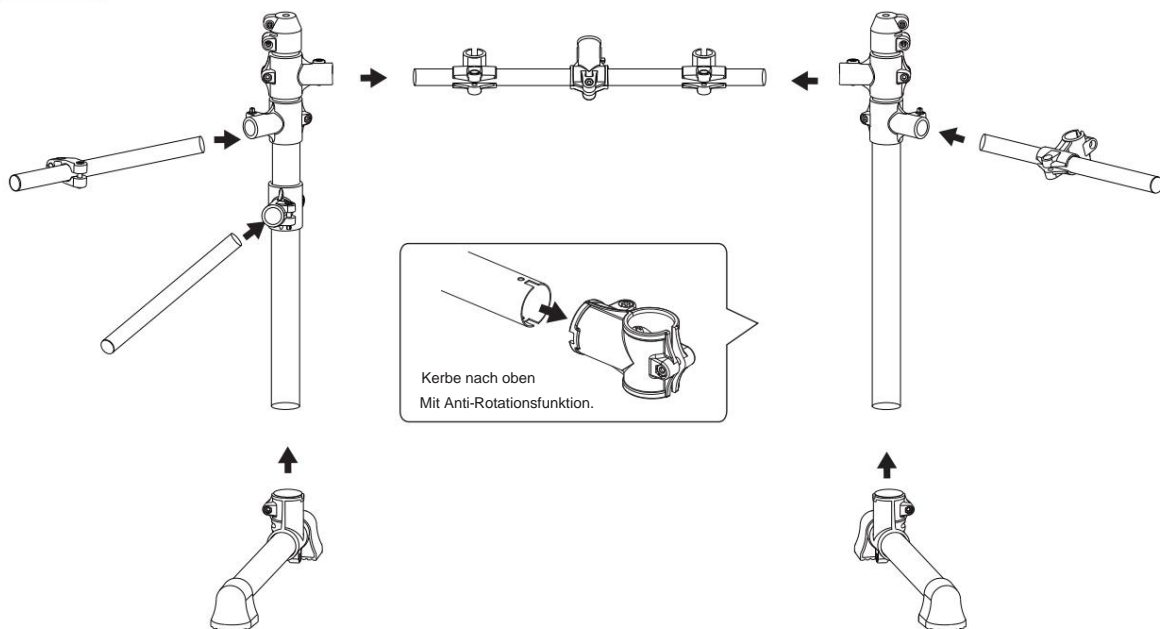



INSTALLATIONSANLEITUNG

04

Installation der Trommelwanne

•Seien Sie bei der Installation bitte vorsichtig und achten Sie darauf, sich nicht die Finger einzuklemmen.

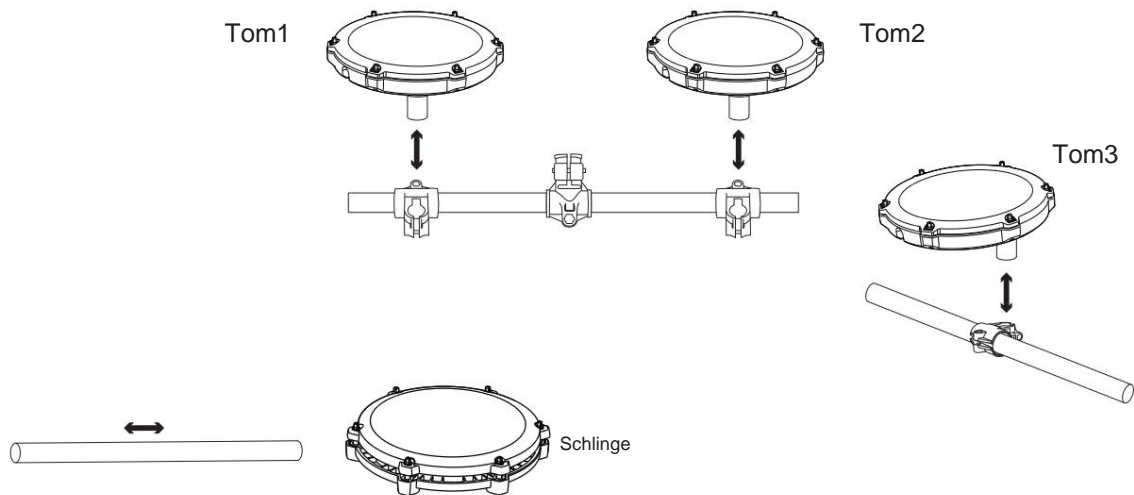

05

Installation des Soundmoduls •

Montieren Sie das Soundmodul mit dem Ständer, bevor Sie es am Schlagzeug befestigen.

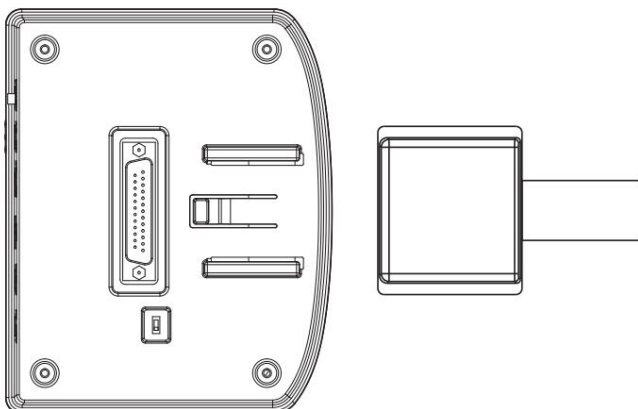

Schieben Sie die Halterung des Hauptkastens in die Schiene des Soundmoduls. Wenn Sie sie bis zum Boden einschieben, hören Sie, wie das Klickstück herauspringt.



06

Becken, Soundmodul installieren, Pedale platzieren

- Achten Sie darauf, das Becken nicht zu fest anzuziehen; lassen Sie etwas Spielraum, damit sich das Becken auf und ab bewegen kann.

Montieren Sie das Becken und das Soundmodul wie in der Abbildung gezeigt auf dem Ständer

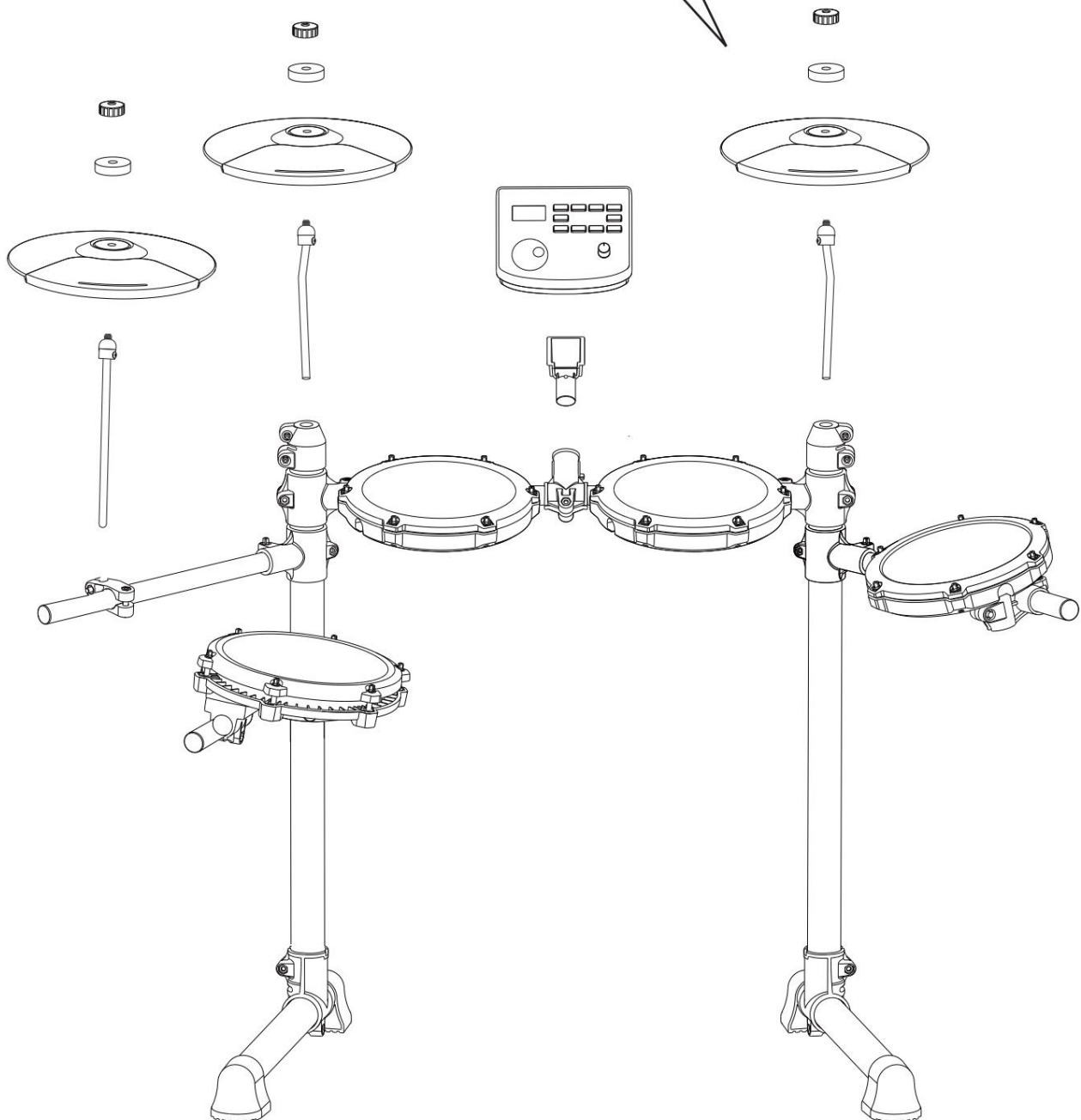
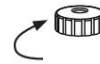



INSTALLATIONSANLEITUNG

07

Anschlusskabel Schlagteil einstecken

•Bitte stecken Sie das Anschlusskabel richtig ein, um einen schlechten Kontakt zu vermeiden, und stecken Sie es wie gezeigt ein. im Diagramm.

Modus A: Mechanische
Kick-Drum

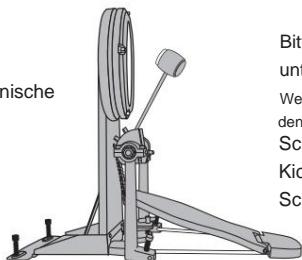

Bitte überprüfen Sie, ob die untere Trommel Geräusche macht, Wenn kein Ton zu hören ist, schalten Sie bitte den Schalter ein.
Schalter in A: mechanischer Kickdrum-Modus,
Schalter in B: Pedalmodus.

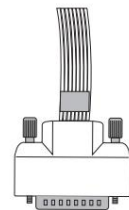

Modus B: Pedal



***Dieses Produkt verwendet Modus B**





ABBILDUNG DES SOUNDMODUL-PORTS

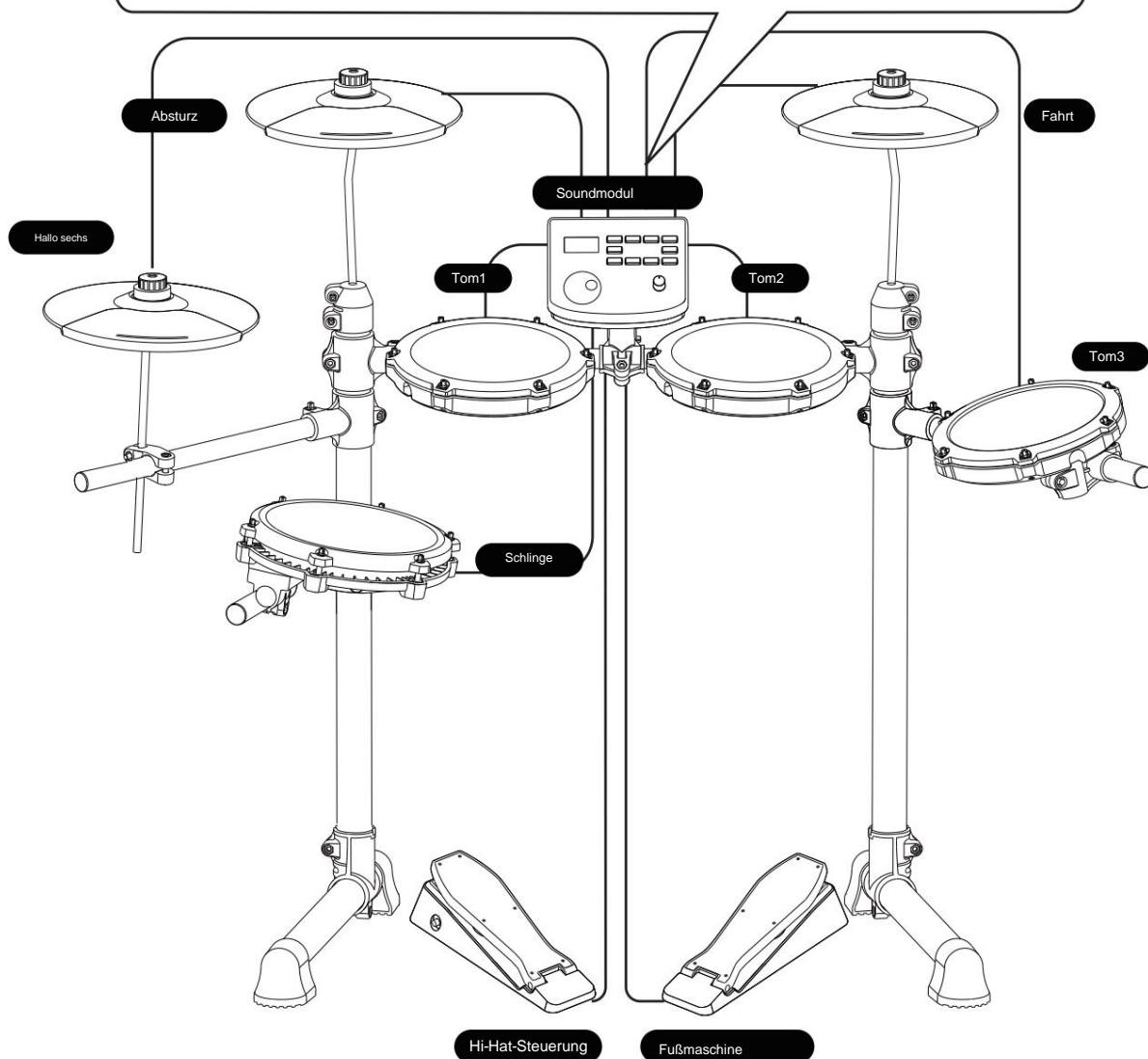
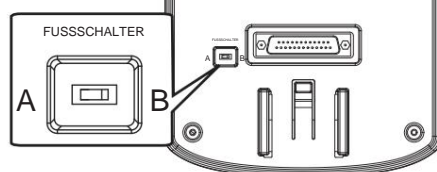
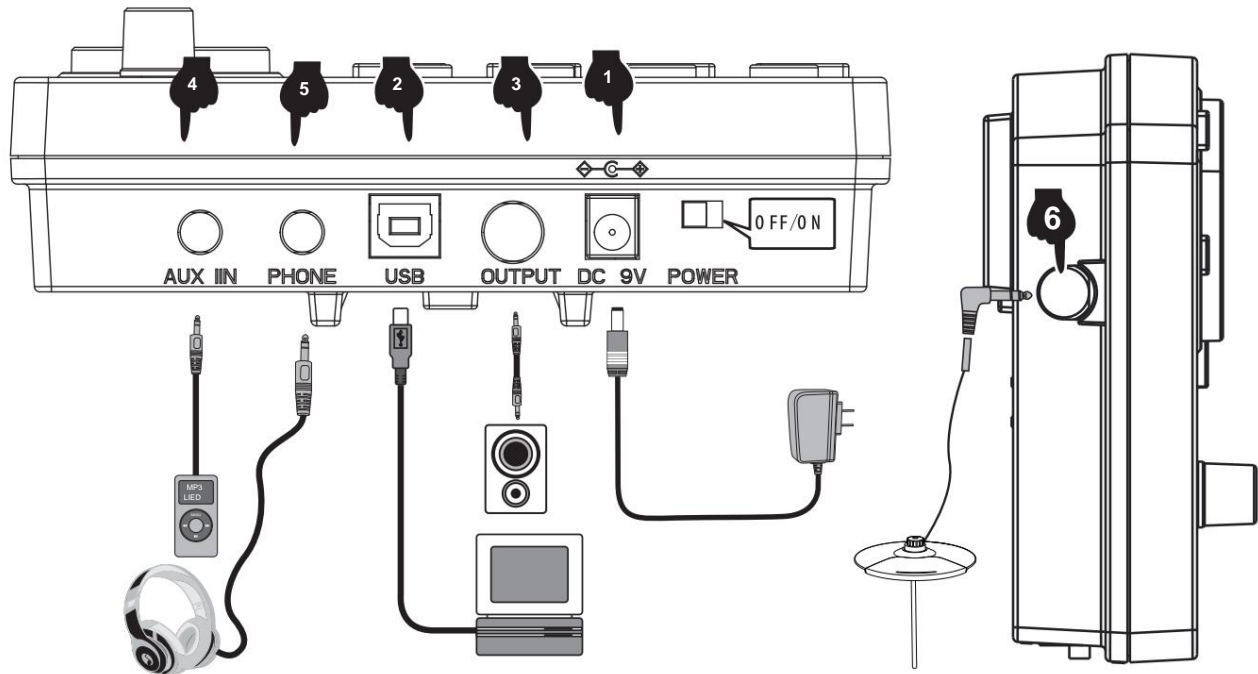

1 NETZKABELANSCHLUSS

1. Bei Verwendung schließen Sie die Stromklemme gemäß dem Diagramm an und stecken Sie die Stromsteckdose der Modulbox an einem Ende und einer 100–240V-Haushaltssteckdose am anderen Ende. (Abb. y1)
2. Wenn Sie das Produkt längere Zeit nicht verwenden, ziehen Sie bitte den Netzstecker und bewahren Sie ihn ordnungsgemäß auf.

2 USB-MIDI-ANSCHLÜSSE

Durch die Verwendung der MIDI-USB-Schnittstelle für elektronische Drums ist die Interaktion mit Musikgeräten über MIDI möglich.

1. Durch die vorinstallierte Musiksoftware auf Computern und Mobiltelefonen können wir lernen, Musik zu spielen, zu komponieren, Speichern und andere Funktionen. (Abb. 2)
2. Bei Anschluss an einen Computer oder ein Mobiltelefon muss der Audioausgang des Geräts mit dem Audio verbunden werden Eingangsbuchse des Soundmoduls, um die Soundeffekte auf dem Gerät zu synchronisieren. (Abb. 5)

3 AUDIO-AUSGANG

An den Audioausgang können Aktivlautsprecher (spezieller E-Drum-Lautsprecher) und große Audiogeräte angeschlossen werden. (Abb. 3)

4 AUDIO-EINGANG

Über den Audioeingang können Sie das Wiedergabegerät der Tonquelle (z. B. MP3, Mobiltelefon und andere Audiosignaleingänge) zur Wiedergabe an die Modulbox anschließen. (Abb. 4)

5 KOPFHÖRER-ANSCHLUSS

Durch den Anschluss von Kopfhörern können Sie die Details der Perkussion mithören und andere nicht stören, wenn Sie ohne angeschlossene Lautsprecher spielen. (Abb. 5)

6 PORT ERHÖHEN

Über diesen Anschluss können Sie zur einfachen Erweiterung ein Becken hinzufügen. (Abbildung 6)



BEDIENERFÜHRUNG

1 LEISTUNG

Stecken Sie den Gleichstromstecker in den 9-V-Gleichstromanschluss oben am Soundmodul. Schieben Sie den POWER-Schalter nach rechts (von vorne gesehen), um das Schlagzeug einzuschalten. Um das Schlagzeug auszuschalten, schieben Sie den Schalter nach links.

2 DRUM-KIT-AUSWAHL

Drücken Sie die KIT-Taste, um das aktuelle Drum-Kit anzuzeigen. Drehen Sie das Parameterrad oder verwenden Sie die Tasten <- /+>, um das gewünschte Schlagzeug-Set. Es stehen 15 Schlagzeug-Sets zur Auswahl – siehe Schlagzeug-Set-Liste auf Seite 11.

3 METRONOM

1. Drücken Sie die METRONOME-Taste, um in den Metronommodus zu wechseln.
2. Auf dem Bildschirm wird der Geschwindigkeitswert angezeigt (Standardgeschwindigkeit 120 BPM). Drehen Sie das Parameterrad oder verwenden Sie die +/- Tasten, um die Metronomgeschwindigkeit zu ändern. Drücken Sie die CLICK-Taste, um das Metronom zu starten.
3. Drücken Sie die SELECT-Taste im Metronommodus, und der Bildschirm springt zum Metronomparameter Anpassungsschnittstelle. Sie können die Tasten +/- drücken, um den Parameter auszuwählen, den Sie anpassen möchten:
 - A. r (Schlagart: 2,4,8,16)
 - B. b (Schlagzahl: 01-09)
 - C. L (Metronomlautstärke: 00 (aus) -31), und drehen Sie dann das Parameterrad, um die Parametereinstellungen anzupassen.
4. Sobald die Parameter eingestellt sind, drücken Sie die SELECT-Taste, um zu bestätigen und den Parameter zu verlassen. Schnittstelle. Dann
5. Mit der Klick-Taste können Sie das Metronom nach Wunsch starten und stoppen.

4 PRAXISFUNKTION

Der Trainermodus dieses Produkts kann dabei helfen, Geschwindigkeit, Genauigkeit und Ausdauer aufzubauen und die Übungsfunktion für ein besseres Rhythmusgefühl. Machen Sie Fortschritte unter Aufsicht des Coach-Modus „Coach“!

Drücken Sie die Taste „Trainer“, um in den Trainermodus zu gelangen. In diesem Modus gibt es drei Übungsmodi. Wählen Sie den Übungsmodus -Modus über das Datenrad oder die Taste <+ > <- >.

1. Übungsmodus 1: C-1-Schlagerkennungsübung: Schlagen Sie die Trommel mit einer festen Geschwindigkeit, um die Genauigkeit des Schlags zu trainieren.
2. Übungsmodus 2: C-2 Silent Strike-Modus: Das Metronom lässt einen Abschnitt erklingen und einen Abschnitt stummschalten, um die Schlaggenauigkeit ohne Metronom-Aufforderung. Es handelt sich um eine erweiterte Version des Übungsmodus 1.
3. Übungsmodus 3: C-3 Geschwindigkeitsschlagübung, das Metronom ändert automatisch die Geschwindigkeit, erhöht sich von der langsamsten Express zum schnellsten, und dann reduzieren von der langsamsten Express auf die langsamste Geschwindigkeit, um die Praxis der Schlagausdauer.

5 COACH-MODUS

1. Der "Coach"-Trainingsmodus dieses Produkts kann dabei helfen, Geschwindigkeit, Genauigkeit und Ausdauer aufzubauen. Drücken Sie die COACH Taste, um in den Trainermodus zu gelangen. In diesem Modus gibt es drei Übungsmodi. Verwenden Sie das Parameterrad, um auszuwählen welcher Übungsmodus.
 - A. Übungsmodus 1: C-1 Übung zur Schlagerkennung – Schlagen Sie die Trommel mit einer festen Geschwindigkeit, um die Genauigkeit des Schlags zu trainieren.
 - B. Übungsmodus 2: C-2 Stiller Anschlagmodus - das Metronom lässt einen Abschnitt erklingen und einen Abschnitt stummschalten, um zu trainieren wenn es keinen Takt gibt.
 - C. Übungsmodus 3: C-3 Geschwindigkeitsschlagübungen - das Metronom ändert automatisch die Geschwindigkeit von der langsamsten zum Schnellsten und dann vom Schnellsten zum Langsamsten.
2. Sobald der Coaching-Modus ausgewählt wurde, drücken Sie die CLICK-Taste. Die Metronomschläge werden gestartet und Sie können Spielen Sie zum Üben auf der Trommel mit.
3. 3. Nach vier vorläufigen Schlägen zeigt das Display:



BEDIENERFÜHRUNG

(zu langsam)



(Gut)



(zu schnell)



4. Sobald Sie den Coaching-Modus abgeschlossen haben, wird eine Punktzahl von 0-100 angezeigt, die die Genauigkeit bewertet die Übung.

C-1-Modus: Drücken Sie die SELECT-Taste, um zur Parametereinstellungsoberfläche zu gelangen. Sie können die Anzahl der Übungseinheiten Sitzungen nach Bedarf (01-32). Die Anzahl der Übungssitzungen bestimmt die Länge dieser Übung.

C-2-Modus: Drücken Sie die SELECT-Taste, um die Parametereinstellungsoberfläche aufzurufen. Sie können die Anzahl der Übungseinheiten Sitzungen nach Bedarf (04-32). Die Anzahl der Übungssitzungen bestimmt die Länge dieser Übung.

C-3-Modus: Drücken Sie die SELECT-Taste, um die Parametereinstellungsoberfläche aufzurufen. Sie können die Rate einstellen, mit der die BPM Änderungen (01-09 BPM).

5. Drücken Sie die CLICK-Taste erneut, um den Coach-Modus zu beenden.

6 DEMO-SONGS

1. Drücken Sie die SONG-Taste, um in den Demo-Modus zu gelangen. Es stehen 30 Demos zur Auswahl. Auf dem Bildschirm wird das aktuelle Demosongnummer (01 -30).

2. Drücken Sie die Taste >, um mit der Wiedergabe der Demosongs zu beginnen. Um die Wiedergabe zu stoppen, drücken Sie erneut die Taste < >.

3. Drehen Sie das Parameterrad oder drücken Sie die Tasten +/-, um einen Demosong auszuwählen.

4. Drücken Sie die SELECT-Taste im Song-Modus, um zur Song-Parameter-Einstellungsoberfläche zu gelangen. Sie können den Drum-Sound einschalten. Durch Drehen des Parameterrads können Sie den Sound ein- oder ausschalten (standardmäßig ist der Drum-Sound eingeschaltet).

5. Drücken Sie zur Bestätigung und zum Verlassen der Parameteroberfläche die Taste „AUSWAHL“.

7 TROMMELPARAMETER

1. Drücken Sie die KIT-Taste und auf dem Display erscheint 01 (Drum-Kit-Nummer). Drücken Sie SELECT, um den Drum-Parameter einzugeben Anpassungsmodus.

2. Tippen Sie auf die Trommel, die Sie anpassen möchten, und drücken Sie dann die Tasten +/-, um den Parameter für die Anpassung auszuwählen. Empfindlichkeit S (01-06). Triggerschwelle t (01 - 32). Übersprechschwelle c (01 -32). Wiederholter Trigger r (01-32) Drum Force V (01-03). Trommelvolumen L (00 - 31).

3. Ändern Sie die Parameter durch Drehen des Parameterrads und drücken Sie zum Speichern lange auf die - Taste. Der Bildschirm mit der Anzeige SAV zeigt an, dass die Parameteranpassung erfolgreich gespeichert wurde.

4. Um die Trommelparameter auf die Werkseinstellungen zurückzusetzen, drücken Sie lange die Taste +, bis auf dem Bildschirm RES.PLEASE angezeigt wird. HINWEIS: Die Parameter für die 3 Tom-Drums können nicht einzeln eingestellt werden.

8 AUFNAHMEFUNKTION

1. Drücken Sie die Taste < REC >, wenn die Kontrollleuchte in den Zuständen "KIT" und "CLICK" leuchtet und auf dem Bildschirm die Wörter „REC“ blinken atmend und wechseln in den Aufnahmevorbereitungszustand.

2. Tippen Sie auf eine beliebige Trommel und das Metronom ertönt. Zu diesem Zeitpunkt zeigt der Bildschirm "---" im blinkenden Zustand der Atmung an und beginnt mit der Aufnahme.

3. Drücken Sie die Taste < REC > oder < PLAY > erneut. Die Aufnahme stoppt und „A-1“ wird auf dem Bildschirm angezeigt.

4. Drücken Sie < ▶ | >, um die Wiedergabe der aktuellen Aufnahme zu starten, und drücken Sie erneut, um die Wiedergabe zu stoppen.

5. Wenn Sie ohne Klopfen erneut in den Aufnahmevorbereitungszustand wechseln, wird das zuletzt aufgenommene „A-1“ wiedergegeben.

9 SPEICHERN / ZURÜCKSETZEN

1. Um die Parameter zu speichern, drücken Sie lange auf die Taste <->. Auf dem Bildschirm wird SAV angezeigt.

2. Um die Parameter zurückzusetzen, drücken Sie lange auf die Taste <+> und auf dem Bildschirm wird RES res angezeigt.

10 USBMIDI

Um die MID-Funktion des Drumkits zu nutzen, stecken Sie ein USB-B-Datenkabel (nicht im Lieferumfang dieses Drumkits enthalten) in die Steuereinheit und mit PC/Smartphone verbinden.



APPENDIX

Timbre

| | | | |
|-------------------------------|------------------------------|----------------------------------|--------------------------------|
| Trete | 39. Jazz-Snare-Rim | 78 . Pop Rock Tom3 | 116. Beliebter Crash2 |
| 1. Funk-Kick | 40. Blues Snare-Rand | 79. Rock Tom3 | 117. Sicherungsabsturz2 |
| 2. Ursprünglicher Kick | 41. Beliebter Snare-Rim | 80. Seesion Tom3 | 118. Dancehall Crash2 |
| 3. Poprock-Kick | 42. Snare-Rim sichern | 81. SpeedMetal Tom3 | 119. Synthgaze Crash2 |
| 4. Rock-Kick | 43. Dancehall-Snare-Rim | 82. Klassisch Trockener Tom3 | 120 . Standard-Crash2 |
| 5. Seesion Kick | 44. Synthgaze Snare Rim | 83. Moderner Tom3 | Fahrt |
| 6. SpeedMetal-Kick | 45. Standard-Snare-Rand | 84. Jazz Tom3 | 121. Funk-Fahrt |
| 7. Klassischer Dry Kick | Tom | 85. Blues Tom3 | 122. Ursprüngliche Fahrt |
| 8 . Modern Kick | 46. Funk Tom1 | 86. Beliebter Tom3 | 123 . Pop-Rock-Fahrt |
| 9. Jazz-Kick | 47. Original von Tom1 | 87. Sicherung Tom3 | 124. Rock Ride |
| 10. Blues Kick | 48 . Pop Rock Tom1 | 88. Dancehall Tom3 | 125. Seesion-Fahrt |
| 11. Beliebter Kick | 49. Rock Tom1 | 89. Synthgaze Tom3 | 126. SpeedMetal-Fahrt |
| 12. Sicherungskick | 50. Seesion Tom1 | 90. Standard Tom3 | 127. Klassisch Trockenfahrt |
| 13. Dancehall-Kick | 51. SpeedMetal Tom1 | Absturz | 128. Moderne Fahrt |
| 14. Synthgaze-Kick | 52. KlassischDry Tom1 | 91. Funk Crash1 | 129. Jazz-Fahrt |
| 15. Standard-Kick | 53. Moderner Tom1 | 92. Original Crash1 | 130. Blues Ride |
| Schlinge | 54. Jazz Tom1 | 93 . Pop Rock Crash1 | 131. Beliebte Fahrt |
| 16. Funk-Snare | 55. Blues Tom1 | 94. Felssturz1 | 132. Sicherungsfahrt |
| 17. Original-Snare | 56. Beliebt Tom1 | 95. Seesion Crash1 | 133. Dancehall-Fahrt |
| 18 . Pop-Rock-Snare | 57. Sicherung Tom1 | 96. SpeedMetal Crash1 | 134. Synthgaze-Fahrt |
| 19. Steinschlinge | 58. Dancehall Tom1 | 97. Klassischer trockener Crash1 | 135. Standardfahrt |
| 20. Seesion-Schlinge | 59. Synthgaze Tom1 | 98. Moderner Crash1 | Hallo Hut |
| 21. SpeedMetal Snare | 60. Standard Tom1 | 99. Jazz Crash1 | 136. Funk Hi-Hat offen |
| 22. Klassische trockene Snare | 61. Funk Tom2 | 100 . Blues Crash1 | 137. Original-Hi-Hat offen |
| 23 . Moderne Snare | 62. Original von Tom2 | 101. Beliebter Absturz1 | 138 . Pop Rock Hi-Hat Open |
| 24. Jazz-Snare | 63 . Pop Rock Tom2 | 102. Sicherungsabsturz1 | 139. Rock Hi-Hat offen |
| 25. Blues-Snare | 64. Rock Tom2 | 103. Dancehall Crash1 | 140. Seesion Hi-Hat Open |
| 26. Beliebte Snare | 65. Seesion Tom2 | 104. Synthgaze Crash1 | 141. SpeedMetal Hi-Hat offen |
| 27. Sicherungsschlinge | 66. SpeedMetal Tom2 | 105. Standard-Crash1 | 142. ClassicDry Hi-Hat offen |
| 28. Dancehall-Snare | 67. Klassisch Trockener Tom2 | 106. Funk Crash2 | 143. Modernes Hi-Hat Open |
| 29. Synthgaze-Snare | 68. Moderner Tom2 | 107. Original Crash2 | 144. Jazz Hi-Hat offen |
| 30. Standard-Snare | 69. Jazz Tom2 | 108 . Poprock Crash2 | 145. Blues Hi-Hat offen |
| 31. Funk-Snare-Rim | 70. Blues Tom2 | 109. Felssturz2 | 146. Beliebtes Hi-Hat Open |
| 32. Original Snare-Rand | 71. Beliebt Tom2 | 110. Seesion Crash2 | 147. Fuse Hi-Hat offen |
| 33 . Pop-Rock-Snare-Reim | 72. Sicherung Tom2 | 111. SpeedMetal Crash2 | 148. Dancehall Hi-Hat Open |
| 34. Rock-Snare-Rand | 73. Dancehall Tom2 | 112. Klassisch Trockener Crash2 | 149. Synthgaze Hi-Hat offen |
| 35. Seesion Snare-Rim | 74. Synthgaze Tom2 | 113. Moderner Absturz2 | 150 . Standard-Hi-Hat offen |
| 36. SpeedMetal Snare-Rand | 75. Standard Tom2 | 114. Jazz Crash2 | 151. Funk Hi-Hat Schließen |
| 37. ClassicDry Snare-Rand | 76. Funk Tom3 | 115. Blues Crash2 | 152. Original Hi-Hat Schließen |
| 38. Moderner Snare-Rim | 77. Original von Tom3 | | |



APPENDIX

| | | |
|----------------------------------|---------------------------------|-----------------------------|
| 153. Poprock Hi-Hat Schließen | 163. Dancehall Hi-Hat Schließen | 173. Modern Hi-Hat Pedal |
| 154. Rock Hi-Hat Schließen | 164. Synthgaze Hi-Hat Schließen | 174. Jazz-Hi-Hat-Pedal |
| 155. Seesion Hi-Hat Schließen | 165. Standard-Hi-Hat-Close | 175. Blues Hi-Hat-Pedal |
| 156. SpeedMetal Hi-Hat Schließen | 166. Funk-Hi-Hat-Pedal | 176. Beliebtes Hi-Hat-Pedal |
| 157. ClassicDry Hi-Hat Schließen | 167. Original Hi-Hat-Pedal | 177. Fuse Hi-Hat-Pedal |
| 158. Modernes Hi-Hat Schließen | 168. Pop Rock Hi-Hat-Pedal | 178. Dancehall-Hi-Hat-Pedal |
| 159. Jazz Hi-Hat Schließen | 169. Rock-Hi-Hat-Pedal | 179. Synthgaze Hi-Hat-Pedal |
| 160. Blues Hi-Hat Schließen | 170. Seesion Hi-Hat-Pedal | 180. Standard-Hi-Hat-Pedal |
| 161. Beliebte Hi-Hat Schließen | 171. SpeedMetal Hi-Hat-Pedal | |
| 162. Fuse Hi-Hat Schließen | 172. ClassicDry Hi-Hat-Pedal | |

Drum combination timbre

Benutzer-Schlagzeug

| | | | | |
|-------------|---------------|---------------|------------|--------------|
| 01 Funk | 04 Rock | 07 ClassicDry | 10 Blues | 13 Dancehall |
| 02 Original | 05 Seesion | 08 Modern | 11 Popular | 14 Synthgaze |
| 03 Poprock | 06 SpeedMetal | 09 Jazz | 12 Fuse | 15 Standard |

Demosong

| | | | | | | | |
|----------|----------|----------|----------|----------|----------|----------|----------|
| Lied 001 | Lied 005 | Lied 009 | Lied 013 | Lied 017 | Lied 021 | Lied 025 | Lied 029 |
| Lied 002 | Lied 006 | Lied 010 | Lied 014 | Lied 018 | Lied 022 | Lied 026 | Lied 030 |
| Lied 003 | Lied 007 | Lied 011 | Lied 015 | Lied 019 | Lied 023 | Lied 027 | |
| Lied 004 | Lied 008 | Lied 012 | Lied 016 | Lied 020 | Lied 024 | Lied 028 | |



PRODUCT MAINTENANCE

Careful maintenance and protection of the product, to extend the service life of the product, reduce the fault has a very important role.

1 AVOID HEATING, DAMPNES OR DIRECT SUNLIGHT

Do not over expose the product to direct sunlight, or place it near air conditioning or extremely hot place.

2 DO NOT USE NEAR THE TV OR RADIO

This product may cause video or audio interference to the reception of TV and radio. If this happens, the product should be removed from the TV or radio.

3 NO DILUENTS OR SIMILAR CHEMICALS SHOULD BE USED FOR CLEANING

Clean the product with a soft cloth wetted with weak water solution and neutral detergent. Soak the cloth in a solution and wring it dry until it approaches drying.

4 DO NOT SHAKE, AVOID COLLISION

When moving, the product should be handled carefully and lightly. Violent vibration and collision are strictly prohibited in order to avoid damage to the shell or internal electronic components.



SAFETY PRECAUTIONS

POWER SUPPLY

This product can be powered by standard indoor wall sockets. Please only use the power cord specified in this product. When not in use, please turn off the power supply. When not in use for a long time, pull out the power cord and keep it properly.

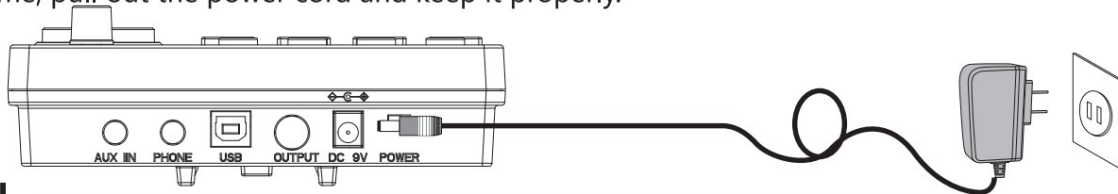

SIGN

To ensure that you use this product safely and correctly, to prevent harm to users and others and financial damage, this manual and products are marked with a series of safety signs. The various signs and their meanings are as follows:

WARNING

This sign indicates that there is a potential risk of death or serious injury if this mark is ignored and the product is mishandled.

BE CAREFUL

This sign indicates that there is a potential danger of injury to personnel or other financial damage if this sign is ignored and the product is operated incorrectly.

EXAMPLE OF LOGO



This triangle sign (Δ) indicates what users should pay attention to. (The left example is careful shocks)



A circular sign (\ominus) with an oblique line indicates prohibitions. The icons in or beside the logo indicate the contents specifically prohibited. (The example on the left is no disassembly)



The round black bottom sign (\odot) indicates what must be observed. The diagrams in this sign indicate the contents of the specific matters that must be observed. (The example on the left is that the power plug must be pulled out of the socket)



SAFETY PRECAUTIONS

WARNING

Smoke, odor, overheating

When the product smokes, smells or overheats, there is a danger of fire and electric shock when it is used continually. In case of the above situation, the following operations should be performed immediately:

1. Turn off the power supply.
2. Pull the plug out of the power outlet.
3. Contact your dealer.

Power cord

1. The improper use of power cord may cause fire and electric shock. The following precautions must be observed:

- The special power cord designated for this product must be used.
- The AC power supply with output voltage within the rated voltage range for household use must be used.
- Do not overload power sockets and extension lines.



2. The improper treatment of power line will lead to its damage or breakage, which will cause fire and electric shock hazards. The following precautions must be observed:

- Do not place or heat heavy objects on power lines.
- Do not attempt to alter or bend the power cord too much.
- Do not twist or pull the power cord.
- If the power cord or plug is damaged, please replace the same type of power cord.



3. Do not touch the power cord and plug with wet hands, otherwise there is a danger of electric shock.



4. Please use the power cord where the water will not splash. Water is in danger of causing fire and electric shock.



5. Never place vases or any other container containing water on this product. Water is dangerous of causing fire and electric shock.



6. Do not allow minors to unplug and touch power lines or connection boards. Minors have no common sense of electricity safety, which may cause electric shock.



BE CAREFUL

The improper use of power cord may cause fire and electric shock. The following precautions must be observed:

- Never put the power cord near the oven or other heat source.
- Do not pull the cable when pulling out of the power socket. The main body of the plug must be grasped.
- The power cord plug must be inserted in the socket to the end.
- Make sure the power supply is off before connecting or disconnecting it.
- When thunderstorms occur or before traveling or other long-term departure, disconnect the power cord from the wall outlet.
- At least once a year, remove the power cord from the wall outlet and clean the dust accumulated around the plug.



Do not burn this product

Do not put this product in the fire, otherwise it will lead to product combustion and explosion of internal electronic components, which will cause fire and personnel injury.



Water and foreign bodies

Water, other liquids and (metal sheets, etc.) entering this product are in danger of causing fire and electric shock. In case of the above situation, the following operations shall be performed immediately:



1. Turn off the power supply.
2. If you are using a power cord for power supply, unplug it from the wall outlet.
3. Contact your distributor.

Disassembly and transformation

Do not disassemble or transform the product in any way, otherwise there is a risk of electric shock, scald or other personal injury. All internal inspection, adjustment and maintenance operations should be entrusted to your distributor.





SAFETY PRECAUTIONS

Falling or colliding

If the product falls or is damaged by strong impact, it will be in danger of causing fire and electric shock. In case of the above situation, the following operations shall be performed immediately:

1. Turn off the power supply.
2. If you are using a power cord for power supply, you need to unplug it from the wall outlet.
3. Contact your distributor.



Plastic bag

Do not let anyone put plastic bags for this product on his head or in his mouth.

Otherwise, there is a risk of asphyxia.

Families with young children should pay special attention to it.



Keep a distance from the product and the bracket

Climbing the bracket is dangerous of overturning or damage. Families with young children should pay special attention to it.



Put

Avoid placing the product on an uneven surface or any other unstable place.

Otherwise, it will cause the product to fall down, which will lead to the risk of injury.



Product Mobility

Before moving this product, you must unplug the power cord plug from the wall outlet and pull out all other cables and connecting wires. Otherwise, it will lead to damage of power or connection wires, resulting in fire and electric shock.



clean

Before cleaning this product, you must unplug the power cord plug from the wall outlet, otherwise there is a risk of fire and electric shock.



Jack

The socket of this product can only be connected to the designated equipment and devices. Connecting non-designated equipment or devices is dangerous of causing fire and electric shock.



Location selection

It should be avoided to place the product in the following places, otherwise there is a risk of fire and electric shock.

- High temperature or dusty places.
- Kitchen or other places with lampblack.
- Where the product is exposed to direct sunlight, or any other place where the product will produce high temperature.



Volume

Don't play music long and loud. Pay special attention when using headphones.

Excessive volume can damage your hearing.



Heavy

Do not place heavy objects on this product. Otherwise, the top of the product will be overweight, causing the product to overturn or drop objects on it, which will lead to the risk of injury.





Correct assembly of scaffolds

The incorrect assembly of the bracket may overturn, causing the product to fall off and posing a risk of injury to personnel.

Therefore, it must be assembled according to the instructions in the attached installation guide to ensure that the product is properly mounted on its bracket.



| | |
|--|---|
|  | <p>Warnung: Um das Verletzungsrisiko zu verringern, muss der Benutzer die Bedienungsanleitung sorgfältig lesen.</p> |
|  | <p>Dieses Gerät entspricht Teil 15 der FCC-Bestimmungen. Der Betrieb unterliegt den folgenden beiden Bedingungen: (1) Dieses Gerät darf keine schädlichen Störungen verursachen und (2) dieses Gerät muss alle empfangenen Störungen akzeptieren, einschließlich Störungen, die einen unerwünschten Betrieb verursachen können.</p> |
|  | <p>Dieses Produkt unterliegt den Bestimmungen der europäischen Richtlinie 2012/19/EU. Das Symbol einer durchgestrichenen Mülltonne weist darauf hin, dass das Produkt in der Europäischen Union einer getrennten Müllentsorgung unterliegt. Dies gilt für das Produkt und alle mit diesem Symbol gekennzeichneten Zubehörteile. So gekennzeichnete Produkte dürfen nicht im normalen Hausmüll entsorgt werden, sondern müssen an einer Sammelstelle für das Recycling von elektrischen und elektronischen Geräten abgegeben werden.</p> |

Hersteller: Shanghaimuxinmuyeyouxiangongsi

Adresse: Shuangchenglu 803nong11hao1602A-1609shi, baoshanqu, Shanghai 200000 CN.

Nach AUS importiert: SIHAO PTY LTD, 1 ROKEVA STREETEASTWOOD NSW 2122 Australien

Importiert in die USA: Sanven Technology Ltd., Suite 250, 9166 Anaheim Place, Rancho Cucamonga, CA 91730

| | |
|--------------------------------|--|
| <p>Vertreter der EG</p> | |
|--------------------------------|--|

E-CrossStu GmbH
Mainzer Landstr.69, 60329 Frankfurt am Main.

| | |
|----------------------|--|
| <p>UK REP</p> | |
|----------------------|--|

YH CONSULTING LIMITED.
C/O YH Consulting Limited Office 147, Centurion House,
London Road, Staines-upon-Thames, Surrey, TW18 4AX

VEVOR®

TOUGH TOOLS, HALF PRICE

Technischer Support und E-Garantie-Zertifikat

www.vevor.com/support

VEVOR®

TOUGH TOOLS, HALF PRICE

Supporto tecnico e certificato di garanzia

elettronica www.vevor.com/support

BATTERIA ELETTRONICA

MANUALE D'USO

MODELLO: MD200C

Continuiamo a impegnarci per fornirvi strumenti a prezzi competitivi.

"Risparmia metà", "Metà prezzo" o qualsiasi altra espressione simile da noi utilizzata rappresenta solo una stima del risparmio che potresti trarre dall'acquistare determinati strumenti con noi rispetto ai principali marchi più importanti e non significa necessariamente coprire tutte le categorie di strumenti offerto da noi. Ti ricordiamo gentilmente di verificare attentamente quando effettui un ordine con noi se stai effettivamente risparmiando la metà rispetto ai migliori marchi principali.

VEVOR[®]
TOUGH TOOLS, HALF PRICE

BATTERIA ELETTRONICA

MODELLO: MD200C

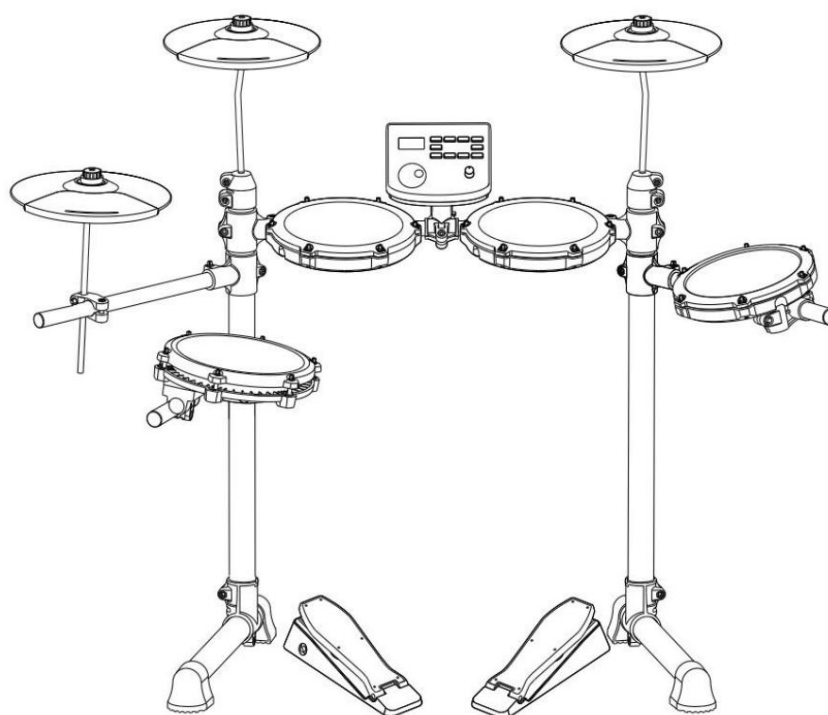

(L'immagine è solo di riferimento, fare riferimento all'oggetto reale)

HO BISOGNO DI AIUTO? CONTATTACI!

Hai domande sul prodotto? Hai bisogno di supporto tecnico? Sentiti libero di contattaci:

Supporto tecnico e certificato di garanzia elettronica

www.vevor.com/support

Queste sono le istruzioni originali, leggere attentamente tutte le istruzioni del manuale prima dell'uso. VEVOR si riserva una chiara interpretazione del nostro manuale d'uso. L'aspetto del prodotto sarà soggetto al prodotto ricevuto. Ti preghiamo di perdonarci se non ti informeremo più se sono presenti aggiornamenti tecnologici o software sul nostro prodotto.



INTRODUZIONE ALLA FUNZIONE

Grazie per aver scelto la nostra batteria elettronica. Il tamburo elettronico elegante e delicato è la combinazione perfetta della nuova tecnologia elettronica moderna. •Prima di utilizzare questo prodotto, è necessario leggere le istruzioni in dettaglio.

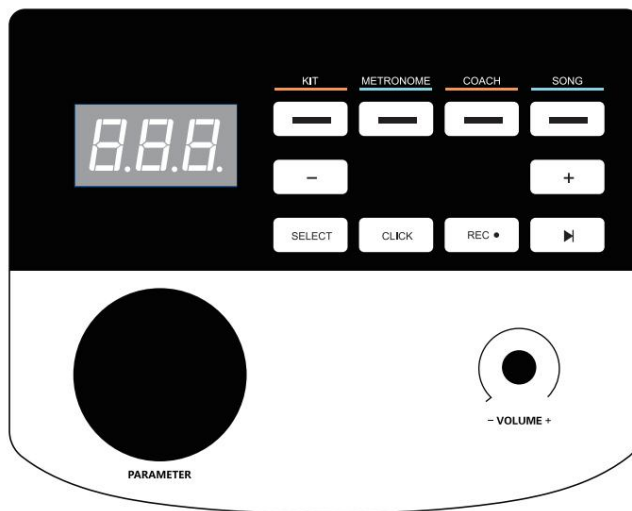

- 15 drum kit, 180 timbri

- 30 brani •

- supportano la regolazione dei parametri di sensibilità di ciascun tamburo •

- tre modalità di insegnamento

- controllo della velocità: 30 ~ 250 battiti/min

- metronomo: 1-9 tipi •

- altre funzioni: memorizzazione, ripristino e registrazione dei

- parametri; • display LED a

- tre cifre; • interfaccia: alimentatore DC, USBmidi, auricolare, ingresso audio, piatto aumento uscita audio

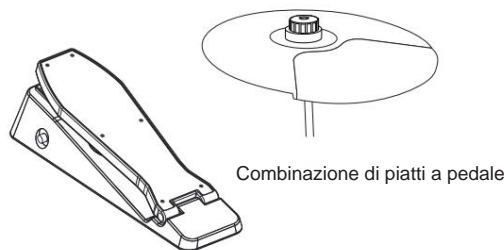

NOTA!

- Questo prodotto è uno strumento elettroacustico. È normale che ci sia un po' di corrente suono nell'altoparlante o nelle cuffie dopo l'accensione.

Tenere lontano da "radio, TV, ricevitori d'antenna, router, frigorifero, TV, motore e altre fonti di interferenza elettrica RF" durante l'uso.



CONTENUTI

| | |
|---|-----------|
| INTRODUZIONE FUNZIONI | 1 |
| CONTENUTO | 2 |
| GUIDA D'INSTALLAZIONE | 3 |
| VERIFICA GLI ARTICOLI ALLEGATI | 3 |
| RACCORDO TUBO SUPPORTO | 4 |
| SUPPORTO DI MONTAGGIO | 4 |
| INSTALLAZIONE DEL TAMBURO | 5 |
| INSTALLAZIONE MODULO SONORO | 5 |
| INSTALLARE I PIATTI, IL MODULO AUDIO E POSIZIONARE I PEDALI | 6 |
| INSERIRE IL CAVO DI COLLEGAMENTO DELLA PARTE BATTENTE | 7 |
| ILLUSTRAZIONE DELLA PORTA DEL MODULO AUDIO | 8 |
| COLLEGAMENTO DEL CAVO DI ALIMENTAZIONE | 8 |
| PORTA MIDI USB | 8 |
| PORTA DI USCITA AUDIO | 8 |
| PORTA DI INGRESSO AUDIO | 8 |
| PORTA PER AURICOLARI | 8 |
| GUIDA OPERATIVA | 9 |
| ENERGIA | 9 |
| SELEZIONE DEL DRUM KIT | 9 |
| METRONOMO | 9 |
| FUNZIONE PRATICA | 9 |
| MODALITÀ ALLENATORE | 9 |
| CANZONE DEMO | 10 |
| PARAMETRI TAMBURO | 10 |
| FUNZIONE DI REGISTRAZIONE | 10 |
| SALVA/AZZERA | 10 |
| USB MIDI | 10 |
| APPENDICE | 11 |
| TIMBRO DEL TAMBURO | 11 |
| KIT TAMBURO PRESET | 11 |
| DRUM KIT DEFINITI DALL'UTENTE | 11 |
| CANTO DIMOSTRATIVO | 11 |
| MANUTENZIONE DEL PRODOTTO | 12 |
| MISURE DI SICUREZZA | 13 |



GUIDA D'INSTALLAZIONE

NOTA!

- Seguire le istruzioni e leggere attentamente le "precauzioni di sicurezza" nel Manuale dell'utente prima di usare .
- Questo prodotto deve essere installato da un adulto, non lasciare che il minore lo installi in modo indipendente.

01

Controlla gli articoli allegati

- Dopo aver aperto la confezione, verificare immediatamente se contiene tutti gli articoli. Se ne mancano, contattare il rivenditore.



Modulo sonoro



Staffa del modulo



Piatto*3



Tom (3 pezzi)



Rullante



Bacchetta per tamburo



Pedale*2



Cavo di collegamento del segnale



Adattatore di alimentazione

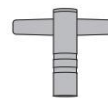

Chiave del tamburo



Braccio da corsa/incidente



Braccio del charleston



GUIDA D'INSTALLAZIONE

02

Raccordo per tubo verticale

• Il supporto si trova in un piccolo pacchetto individuale all'interno della scatola.

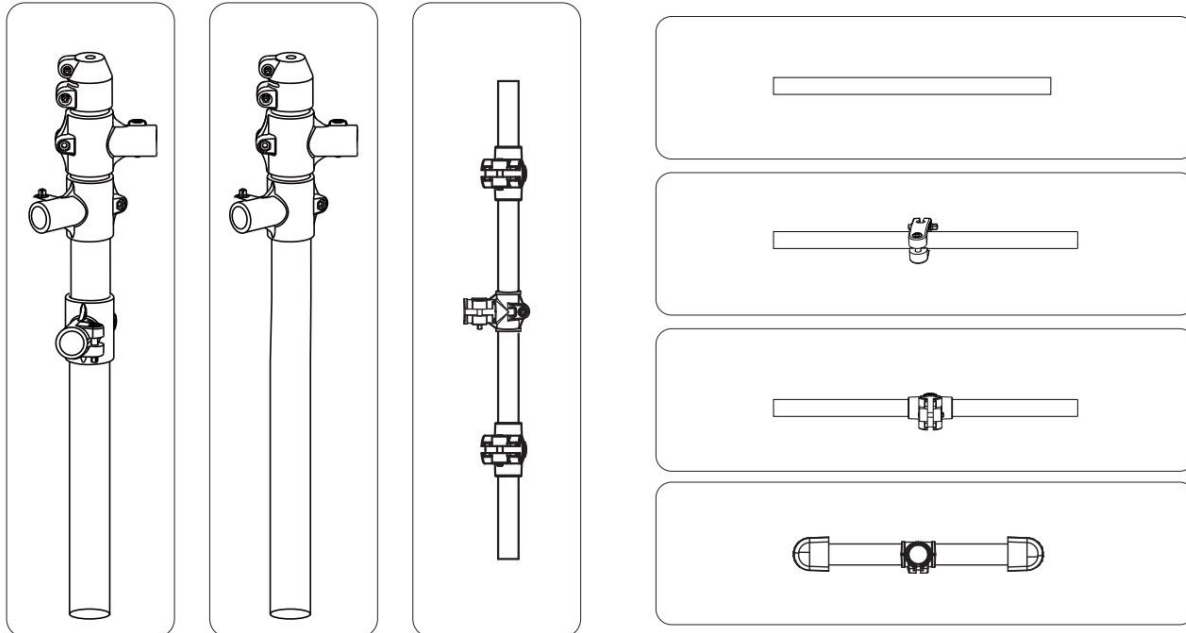

Supporto di montaggio

03 • Il supporto deve essere installato in posizione e avvitare le viti con la chiave del tamburo.

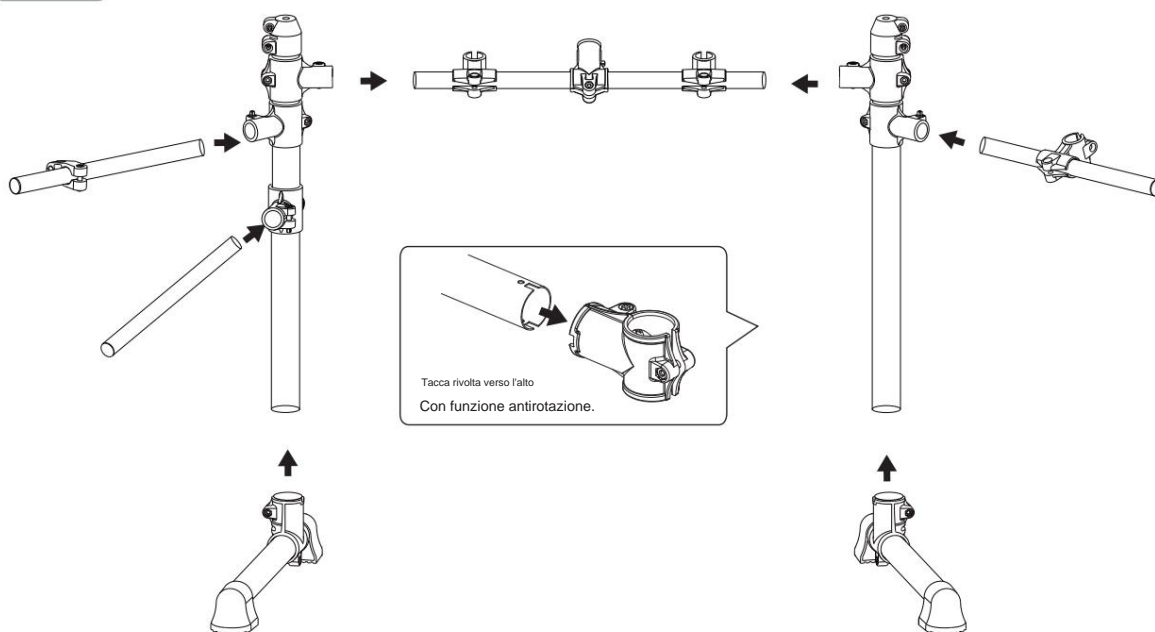



GUIDA D'INSTALLAZIONE

04

Installazione della vasca per fusti

• Fare attenzione a non pizzicarsi le dita durante l'installazione.

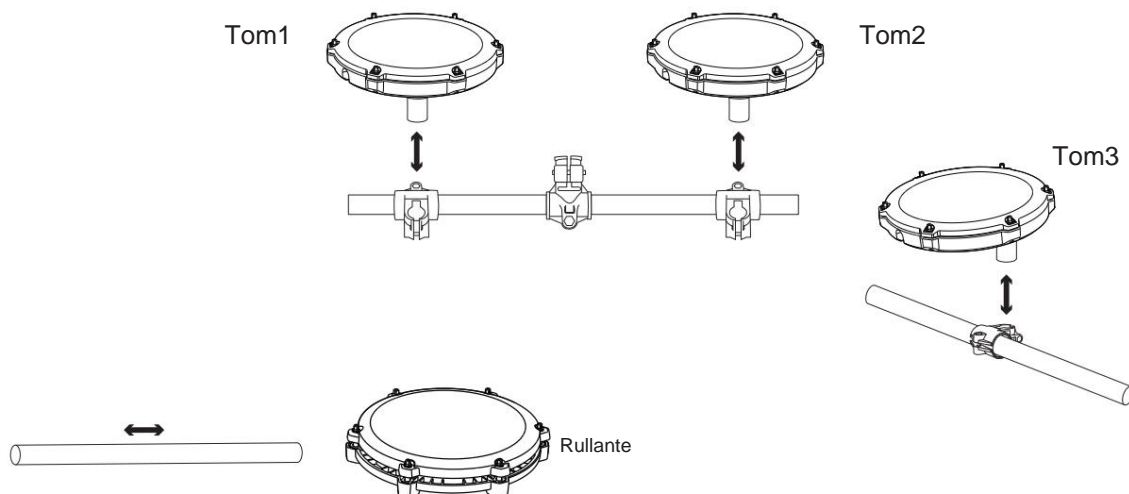

05

Installazione del modulo sonoro •

Assemblare il modulo sonoro con il supporto prima di collegarlo al kit per batteria.

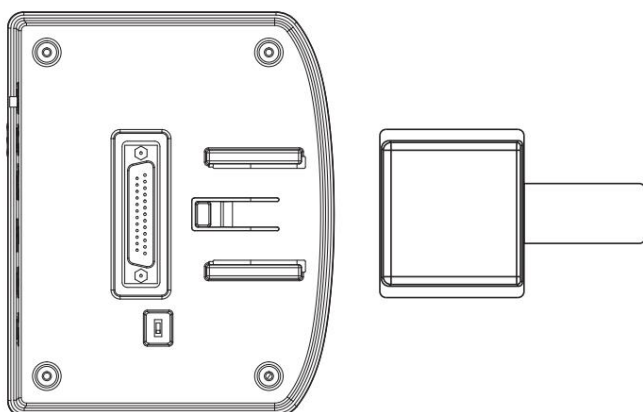

Inserisci la staffa della scatola principale contro la traccia del modulo sonoro e sentirai il clic apparire quando lo inserisci fino in fondo.



GUIDA D'INSTALLAZIONE

06

Installa i piatti, il modulo sonoro, posiziona i pedali

- Assicurarsi di non stringere troppo i piatti, lasciare un po' di spazio affinché possano muoversi su e giù.

Installa il piatto e il modulo sonoro sul supporto come mostrato nell'immagine

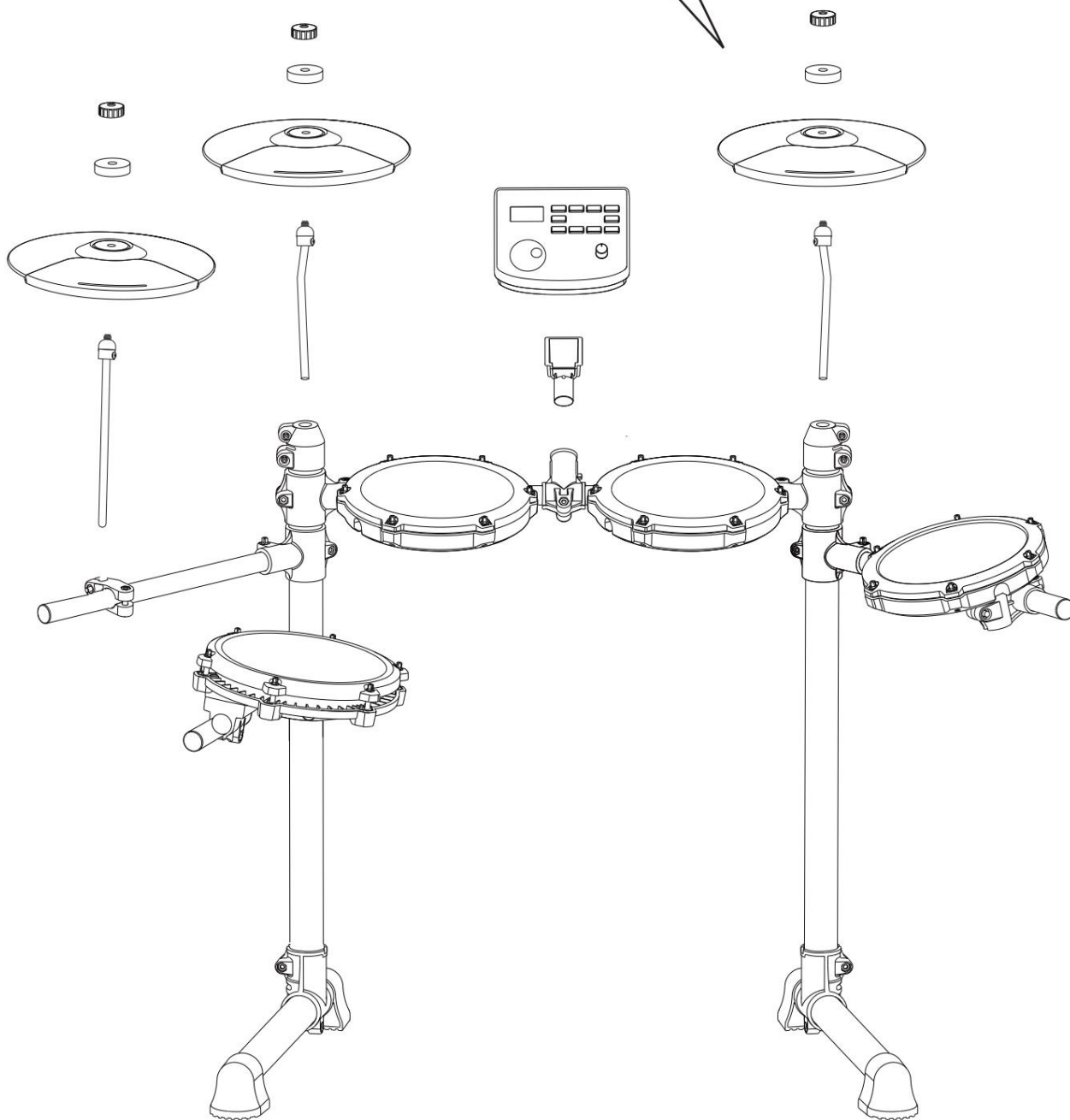



GUIDA D'INSTALLAZIONE

07

Inserire il cavo di collegamento della parte colpita

•Si prega di inserire il cavo di collegamento in posizione per evitare un cattivo contatto e inserirlo correttamente come mostrato nel diagramma.





ILLUSTRAZIONE DELLA PORTA DEL MODULO AUDIO

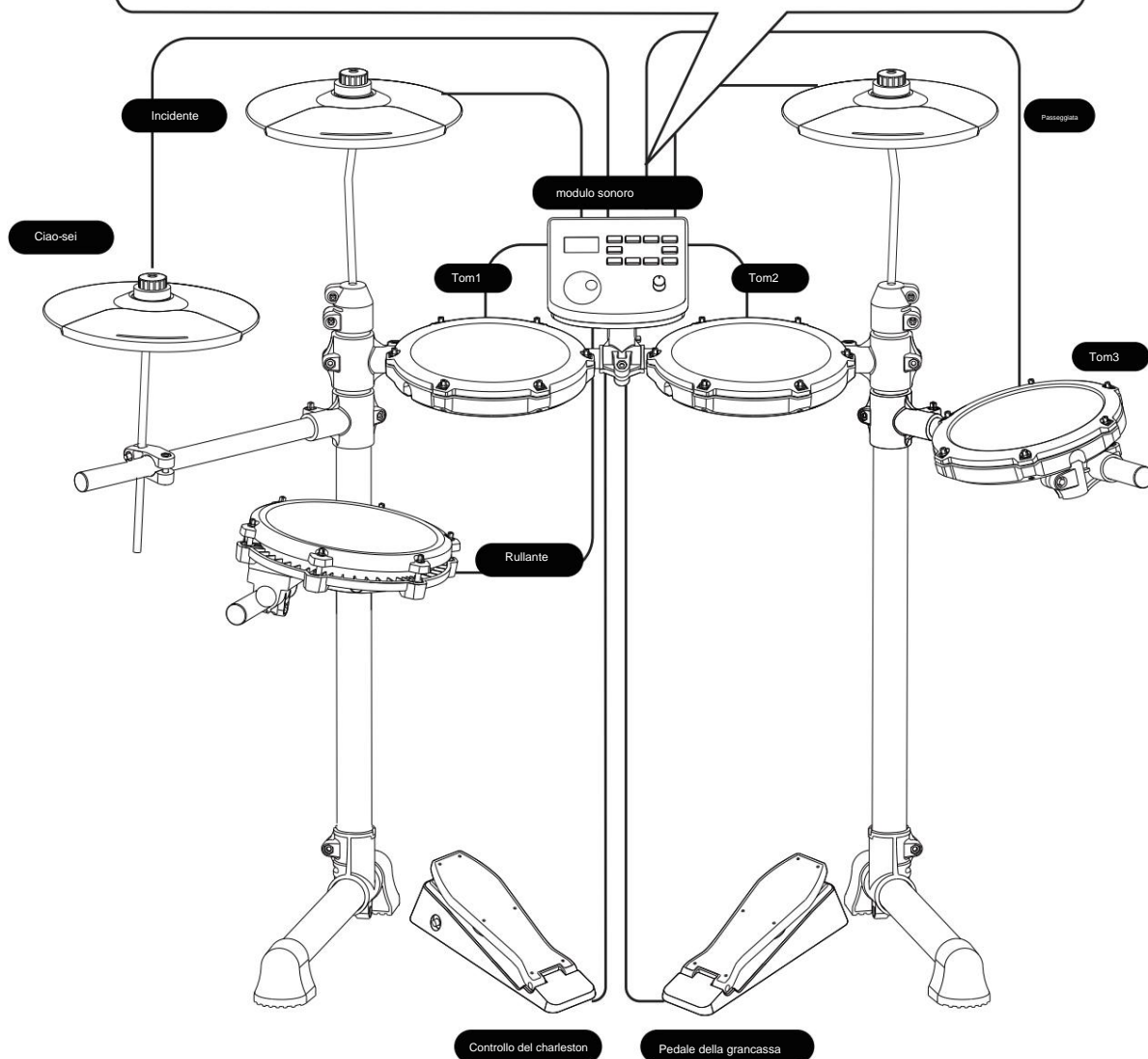
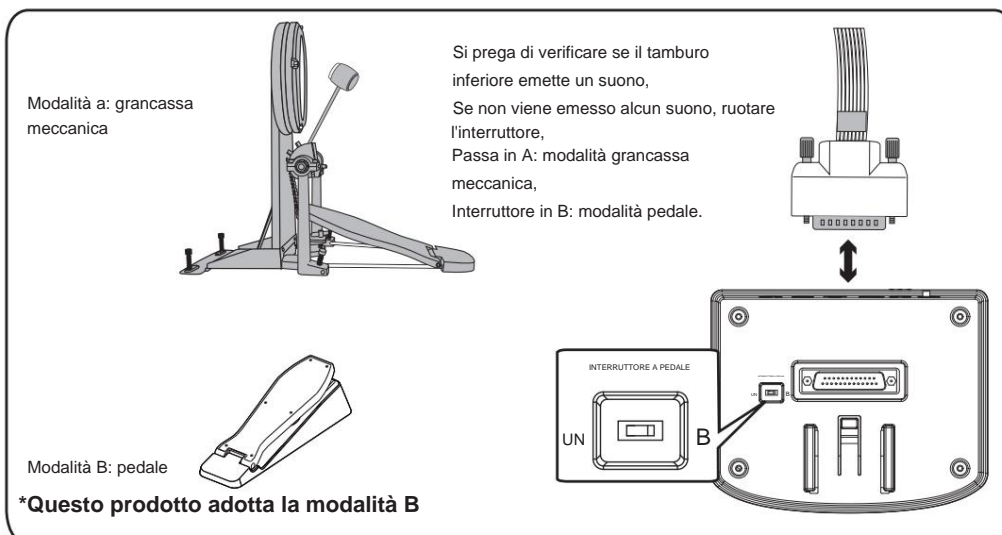
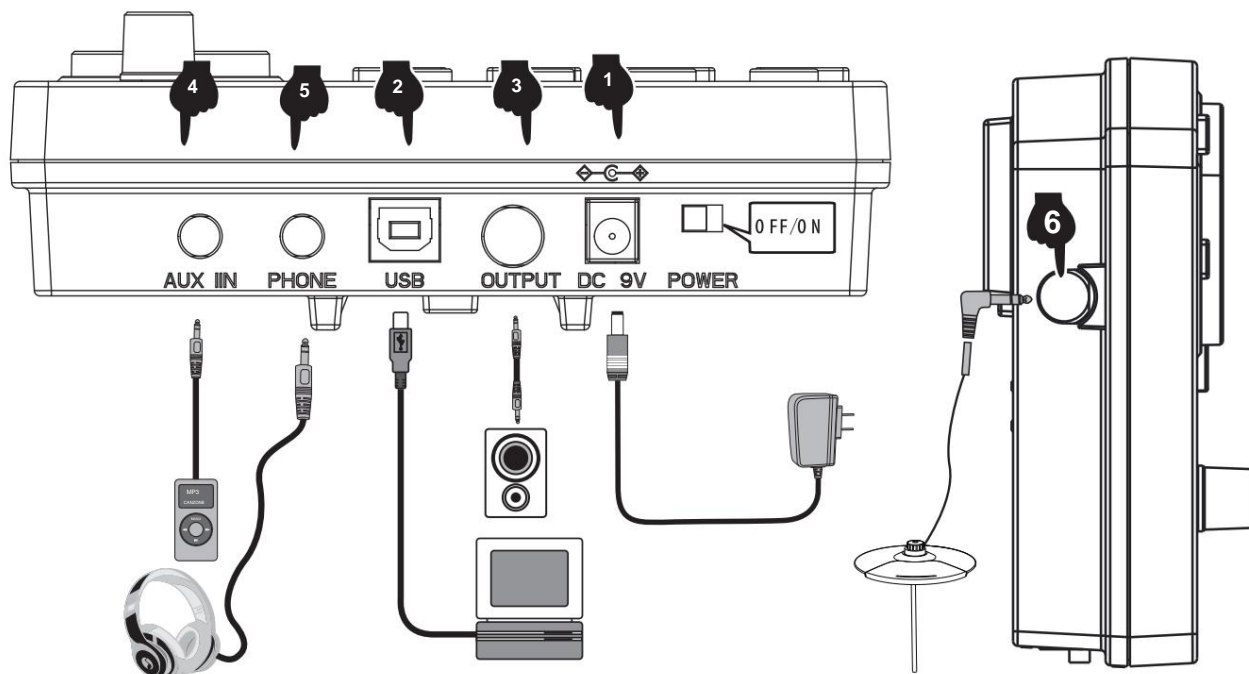

1 COLLEGAMENTO DEL CAVO DI ALIMENTAZIONE

1. Quando è in uso, collegare il terminale di alimentazione secondo lo schema, inserire la presa di corrente della scatola del modulo in un'estremità e una presa di corrente domestica da 100-240 V all'altra estremità. (Fig. 1)
2. Se non si utilizza questo prodotto per un lungo periodo, staccare la spina di alimentazione e conservarla correttamente.

2 PORTA MIDI USB

L'uso dell'interfaccia USB MIDI MIDI per batteria elettronica può interagire con dispositivi musicali con MIDI.

1. Attraverso il software Musica preinstallato su computer e telefoni cellulari, possiamo imparare a suonare, comporre musica, negozio e altre funzioni. (Fig. 2)
2. Quando è collegato a un computer o telefono cellulare, l'uscita audio del dispositivo deve essere collegata all'audio presa di ingresso del modulo audio per sincronizzare gli effetti sonori sul dispositivo. (figura 5)

3 PORTA DI USCITA AUDIO

La porta di uscita audio può essere collegata ad un altoparlante attivo (altoparlante speciale per batteria elettronica) e ad apparecchiature audio di grandi dimensioni. (figura 3)

4 PORTA DI INGRESSO AUDIO

La porta di ingresso audio può collegare il dispositivo di riproduzione della sorgente audio al box del modulo per la riproduzione (come MP3, telefono cellulare e altro ingresso di segnale audio). (Fig. 4)

5 PORTA PER AURICOLARI

Il collegamento delle cuffie monitora i dettagli delle percussioni e non disturba gli altri quando si suona senza collegare gli altoparlanti. (figura 5)

6 AUMENTA PORTA

Questa porta consente di aggiungere un piatto per una facile espansione. (Figura 6)



GUIDA OPERATIVA

1 POTENZA

Inserire la spina CC nella porta CC 9 V sulla parte superiore del modulo audio. Far scorrere l'interruttore POWER verso destra (visto dalla parte anteriore) per accendere il drum kit. Per spegnere il drum kit, far scorrere l'interruttore verso sinistra.

2 SELEZIONE DEL KIT TAMBURO

Premere il pulsante KIT per mostrare il drum kit corrente. Girare la rotella dei parametri o utilizzare i pulsanti <- /> per selezionare kit di batteria desiderato. Sono disponibili 15 kit di batteria tra cui scegliere: vedere l'elenco dei kit di batteria a pagina 11.

3 METRONOMO

1. Premere il pulsante METRONOME per accedere alla modalità metronomo.
2. Lo schermo visualizzerà il valore della velocità (velocità predefinita 120 BPM). Gira la rotella dei parametri o usa i tasti +/- pulsanti per modificare la velocità del metronomo. Premere il pulsante CLICK per avviare il metronomo.
3. Premere il pulsante SELECT in modalità metronomo e lo schermo passerà al parametro del metronomo interfaccia di regolazione. È possibile premere i pulsanti +/- per selezionare il parametro che si desidera regolare:
 - A. rȳtipo di battuta: 2, 4, 8, 16ȳ
 - B. b (numero di battute: 01-09)
 - C. L (volume metronomo: 00 (off) -31), quindi girare la rotella dei parametri per regolare le impostazioni dei parametri.
4. Una volta regolati i parametri, premere il pulsante SELEZIONE per confermare e uscire dal parametro interfaccia. Quindi
5. Utilizzare il pulsante clic per avviare e arrestare il metronomo come desiderato.

4 FUNZIONE PRATICA

La modalità "allenatore" di questo prodotto può aiutare a stabilire velocità, precisione e resistenza e aiutare a coltivare la pratica funzione di un migliore senso del ritmo. Fai progressi sotto la supervisione della modalità allenatore "allenatore"! Premere il pulsante "coach" per accedere alla modalità allenatore. In questa modalità, ci sono tre modalità di pratica. Seleziona la pratica modalità tramite la ruota dati o il pulsante < + > < - >.

1. Modalità di esercizio 1: Esercizio di rilevamento del battito C-1: batti il tamburo a una velocità fissa per allenare la precisione del colpo.
2. Modalità pratica 2: modalità colpo silenzioso C-2: il metronomo suonerà una sezione e silenzierà una sezione per addestrare il precisione del colpo senza il prompt del metronomo. È una versione avanzata della modalità pratica 1.
3. Modalità pratica 3: pratica del colpo di velocità C-3, il metronomo cambierà automaticamente la velocità, aumenterà da dall'espresso più lento al più veloce, quindi ridurre dall'espresso più lento alla velocità più lenta, in modo da esercitarsi resistenza allo sciopero.

5 MODALITÀ ALLENATORE

1. La modalità di allenamento "coach" di questo prodotto può aiutare a stabilire velocità, precisione e resistenza. Premere COACH pulsante per accedere alla modalità allenatore. In questa modalità, ci sono tre modalità di pratica. Usa la ruota dei parametri per selezionare quale modalità pratica.
 - A. Modalità di esercizio 1: Esercizio di rilevamento del battito C-1: batti il tamburo a una velocità fissa per allenare la precisione del colpo.
 - B. Modalità pratica 2: modalità C-2 colpo silenzioso: il metronomo suonerà una sezione e disattiverà una sezione per allenarsi quando non c'è battito.
 - C. Modalità pratica 3: pratica del colpo di velocità C-3: il metronomo cambierà automaticamente la velocità dalla più lenta al più veloce e poi dal più veloce al più lento.
2. Una volta scelta la modalità coaching, premere il pulsante CLIC. I battiti del metronomo inizieranno e tu potrai farlo suonare il tamburo per esercitarsi.
3. Dopo quattro battute preliminari, il display mostrerà:



GUIDA OPERATIVA

(troppo lento)



(Bene)



(troppo veloce)



4. Una volta completata la modalità coaching verrà visualizzato un punteggio da 0 a 100 valutandone la precisione l'esercizio.

Modalità C-1: premere il pulsante SELEZIONA per accedere all'interfaccia di impostazione dei parametri. Puoi regolare il numero di esercizi sessioni come richiesto (01-32). Il numero di sessioni per esercitarsi determina la durata di questo esercizio.

Modalità C-2: premere il pulsante SELEZIONA per accedere all'interfaccia di impostazione dei parametri. È possibile regolare il numero di esercizi sessioni come richiesto (04-32). Il numero di sessioni di pratica determina la durata di questo esercizio.

Modalità C-3: premere il pulsante SELEZIONA per accedere all'interfaccia di impostazione dei parametri. È possibile regolare la velocità con cui il BPM modifiche (01-09 BPM).

5. Premere nuovamente il pulsante CLIC per terminare la modalità coach.

6 BRANI DIMOSTRATIVI

1. Premere il pulsante SONG per accedere alla modalità demo, ci sono 30 demo tra cui scegliere. Lo schermo visualizzerà il numero del brano demo corrente (01 -30).
2. Premere il pulsante per avviare la riproduzione dei brani dimostrativi. Per interrompere la riproduzione, premere nuovamente il pulsante > .
3. Girare la rotella dei parametri o premere i pulsanti +/- per selezionare una demo song.
4. Premere il pulsante sELECT in modalità canzone per passare all'interfaccia di impostazione dei parametri della canzone. È possibile attivare il suono della batteria attivare o disattivare ruotando la rotella dei parametri (il suono della batteria è attivo per impostazione predefinita).
5. Premere il pulsante SELEZIONE per confermare e uscire dall'interfaccia dei parametri.

7 PARAMETRI DEL TAMBURO

1. Premere il pulsante KIT e lo schermo visualizzerà 01 (numero del kit di batteria). Premere SELECT per accedere al parametro della batteria modalità di regolazione.
 2. Tocca il tamburo che desideri regolare, quindi premi i pulsanti +/- per selezionare il parametro da regolare. Sensibilità S (01-06). Soglia di attivazione t(01 - 32). Soglia di diafonia c (01 -32) Trigger ripetuto r(01-32) Forza tamburo V(01-03). Volume del tamburo L (00 - 31).
 3. Modificare i parametri ruotando la rotella dei parametri e premere a lungo il pulsante - per salvare. Lo schermo con display SAV per indicare che la regolazione del parametro è stata salvata con successo.
 4. Per ripristinare i parametri del tamburo alle impostazioni di fabbrica, premere a lungo il pulsante + finché sullo schermo non viene visualizzato RES.PLEASE
- NOTA: i parametri per i 3 tom non possono essere impostati individualmente.

8 FUNZIONE DI REGISTRAZIONE

1. Premere il pulsante < REC > quando l'indicatore luminoso è negli stati "KIT" e "CLICK" e lo schermo visualizza il parole "REC" nello stato lampeggiante di respirazione, entrando nello stato di preparazione della registrazione.
2. Tocca un tamburo qualsiasi e il metronomo suona. A questo punto, lo schermo visualizza "---" nello stato di respirazione lampeggiante e inizia a registrare.
3. Premere nuovamente il tasto < REC > o < PLAY >, la registrazione si interrompe e sullo schermo viene visualizzato "A-1".
4. Premere < > per avviare la riproduzione della registrazione corrente e premere nuovamente per interrompere la riproduzione.
5. Se si entra nuovamente nello stato di preparazione della registrazione senza bussare, viene riprodotto il brano "A-1" registrato l'ultima volta.

9 SALVA/RESET

1. Per salvare i parametri premere a lungo il pulsante <-> e lo schermo visualizzerà SAV.
2. Per ripristinare i parametri, premere a lungo il pulsante <+> e lo schermo visualizzerà RES res.

10 USBMIDI

Per utilizzare la funzione MID del drum kit, collegare un cavo dati USB-B (non incluso con questo drum kit) all'unità di controllo e connettersi al PC/Smartphone.

**APPENDIX****Timbre****Calcio**

- 1 . Funk Calcio
 - 2 . Calcio originale
 - 3 . Calcio poprock
 - 4 . Calcio di roccia
 - 5 . Calcio di visione
 - 6 . Calcio SpeedMetal
 - 7 . Calcio secco classico
 - 8° . Calcio moderno
 - 9 . Calcio jazz
 - 10 . Calcio dei Blues
 - 11 . Calcio popolare
 - 12 . Calcio con fusibile
 - 13 . Calcio da sala da ballo
 - 14 . Calcio Synthgaze
 - 15 . Calcio standard
- Rullante**
- 16 . Rullante Funk
 - 17 . Rullante originale
 - 18 . Rullante pop-rock
 - 19 . Rullante da roccia
 - 20 . Rullante Seesion
 - 21 . Rullante SpeedMetal
 - 22 . Rullante classico a secco
 - 23 . Rullante moderno
 - 24 . Rullante jazz
 - 25 . Rullante Blues
 - 26 . Rullante popolare
 - 27 . Rullante con fusibile
 - 28 . Rullante Dancehall
 - 29 . Rullante Synthgaze
 - 30 . Rullante standard
 - 31 . Cerchio del rullante Funk
 - 32 . Cerchio del rullante originale
 - 33 . Rima di rullante pop rock
 - 34 . Cerchio del rullante Rock
 - 35 . Cerchio del rullante Seesion
 - 36 . Cerchio del rullante SpeedMetal
 - 37 . Cerchio del rullante ClassicDry
 - 38 . Cerchio del rullante moderno

- 39 . Cerchio del rullante jazz
- 40 . Cerchio del rullante Blues
- 41 . Popolare bordo del rullante
- 42 . Bordo del rullante con fusibile
- 43 . Cerchio del rullante Dancehall
- 44 . Bordo del rullante Synthgaze
- 45 . Cerchio del rullante standard

Tom

- 46 . Funk Tom1
- 47 . Tom originale1
- 48 . Pop-Rock Tom1
- 49 . Rock Tom1
- 50 . Consultazione Tom1
- 51 . SpeedMetal Tom1
- 52 . ClassicDry Tom1
- 53 . Tom moderno1
- 54 . Jazz Tom1
- 55 . Blues Tom1
- 56 . Tom popolare1
- 57 . Fusibile Tom1
- 58 . Dancehall Tom1
- 59 . Synthgaze Tom1
- 60 . Tom standard1
- 61 . Funk Tom2
- 62 . Tom2 originale
- 63 . Pop-Rock Tom2
- 64 . Roccia Tom2
- 65 . Consultazione Tom2
- 66 . SpeedMetal Tom2
- 67 . ClassicDry Tom2
- 68 . Tom moderno2
- 69 . Jazz Tom2
- 70 . Blues Tom2
- 71 . Tom2 popolare
- 72 . Fusibile Tom2
- 73 . Dancehall Tom2
- 74 . Synthgaze Tom2
- 75 . Tom standard2
- 76 . Funk Tom3
- 77 . Tom3 originale

- 78 . Pop-Rock Tom3
- 79 . Rock Tom3
- 80 . Consultazione Tom3
- 81 . SpeedMetal Tom3
- 82 . ClassicDry Tom3
- 83 . Tom moderno3
- 84 . Jazz Tom3
- 85 . Blues Tom3
- 86 . Popolare Tom3
- 87 . Fusibile Tom3
- 88 . Dancehall Tom3
- 89 . Synthgaze Tom3
- 90 . Tom standard3

Incidente

- 91 . Funk Crash1
- 92 . Crash originale1
- 93 . Pop Rock Crash1
- 94 . Schianto di rocce1
- 95 . Seesion Crash1
- 96 . SpeedMetal Crash1
- 97 . ClassicDry Crash1
- 98 . Crash moderno1
- 99 . Jazz Crash1
- 100 . Blues Crash1
- 101 . Crash popolare1
- 102 . Crash del fusibile1
- 103 . Crash nella sala da ballo1
- 104 . Synthgaze Crash1
- 105 . Crash standard1
- 106 . Funk Crash2
- 107 . Crash originale2
- 108 . Poprock Crash2
- 109 . Schianto di rocce2
- 110 . Seesion Crash2
- 111 . SpeedMetal Crash2
- 112 . ClassicDry Crash2
- 113 . Crash moderno2
- 114 . Jazz Crash2
- 115 . Blues Crash2

- 116 . Crash popolare2
- 117 . Fusibile Crash2
- 118 . Crash nella sala da ballo2
- 119 . Synthgaze Crash2
- 120 . Crash standard2

Passeggiata

- 121 . Giro Funk
- 122 . Giro originale
- 123 . Giro pop-rock
- 124 . Giro sulla roccia
- 125 . Giro della visita
- 126 . Giro in SpeedMetal
- 127 . Giro a secco classico
- 128 . Giro moderno
- 129 . Giro del jazz

- 130 . Giro del Blues
- 131 . Giro popolare
- 132 . Giro del fusibile
- 133 . Giro nella sala da ballo
- 134 . Giro Synthgaze
- 135 . Giro standard

Ciao-Hat

- 136 . Funk Hi-Hat aperto
- 137 . Hi-Hat originale aperto
- 138 . Hi-Hat pop rock aperto
- 139 . Rock Hi-Hat aperto
- 140 . Sessione Hi-Hat aperta
- 141 . Hi-Hat SpeedMetal aperto
- 142 . Hi-Hat ClassicDry aperto
- 143 . Hi-Hat moderno aperto
- 144 . Jazz Hi-Hat aperto
- 145 . Blues Hi-Hat aperto
- 146 . Popolare charleston aperto
- 147 . Fusibile del charleston aperto
- 148 . Dancehall Hi-Hat aperto
- 149 . Synthgaze Hi-Hat aperto
- 150 . Hi-Hat standard aperto
- 151 . Funk Hi-Hat Chiudi
- 152 . Chiusura del charleston originale



APPENDIX

| | | |
|--|--|---------------------------------------|
| 153 . Chiudi il charleston Poprock | 163 . Chiudi il charleston Dancehall | 173. Moderno pedale del charleston |
| 154 . Rock Hi-Hat Chiudi | 164 . Chiudi il charleston Synthgaze | 174 . Pedale del charleston jazz |
| 155 . Chiusura della sessione Hi-Hat | 165 . Chiusura del charleston standard | 175 . Pedale del charleston blues |
| 156 . Chiudi il charleston SpeedMetal | 166 . Pedale del charleston Funk | 176 . Popolare pedale charleston |
| 157 . Chiusura del charleston ClassicDry | 167 . Pedale charleston originale | 177 . Pedale charleston Fuse |
| 158 . Chiusura moderna del charleston | 168 . Pedale del charleston pop rock | 178 . Pedale del charleston Dancehall |
| 159 . Chiusura del charleston jazz | 169 . Pedale rock del charleston | 179 . Pedale charleston Synthgaze |
| 160 . Chiusura del charleston blues | 170 . Pedale Hi-Hat Seesion | 180 . Pedale charleston standard |
| 161 . Popolare Hi-Hat Chiudi | 171 . Pedale charleston SpeedMetal | |
| 162 . Chiudi il fusibile del charleston | 172 . Pedale charleston ClassicDry | |

Drum combination timbre

Kit batteria utente

| | | | | |
|-------------|---------------|---------------|------------|--------------|
| 01 Funk | 04 Rock | 07 ClassicDry | 10 Blues | 13 Dancehall |
| 02 Original | 05 Seesion | 08 Modern | 11 Popular | 14 Synthgaze |
| 03 Poprock | 06 SpeedMetal | 09 Jazz | 12 Fuse | 15 Standard |

Canzone dimostrativa

| | | | | | | | |
|-------------|-------------|-------------|-------------|-------------|-------------|-------------|-------------|
| Canzone 001 | Canzone 005 | Canzone 009 | Canzone 013 | Canzone 017 | Canzone 021 | Canzone 025 | Canzone 029 |
| Canzone 002 | Canzone 006 | Canzone 010 | Canzone 014 | Canzone 018 | Canzone 022 | Canzone 026 | Canzone 030 |
| Canzone 003 | Canzone 007 | Canzone 011 | Canzone 015 | Canzone 019 | Canzone 023 | Canzone 027 | |
| Canzone 004 | Canzone 008 | Canzone 012 | Canzone 016 | Canzone 020 | Canzone 024 | Canzone 028 | |



PRODUCT MAINTENANCE

Careful maintenance and protection of the product, to extend the service life of the product, reduce the fault has a very important role.

1 AVOID HEATING, DAMPNES OR DIRECT SUNLIGHT

Do not over expose the product to direct sunlight, or place it near air conditioning or extremely hot place.

2 DO NOT USE NEAR THE TV OR RADIO

This product may cause video or audio interference to the reception of TV and radio. If this happens, the product should be removed from the TV or radio.

3 NO DILUENTS OR SIMILAR CHEMICALS SHOULD BE USED FOR CLEANING

Clean the product with a soft cloth wetted with weak water solution and neutral detergent. Soak the cloth in a solution and wring it dry until it approaches drying.

4 DO NOT SHAKE, AVOID COLLISION

When moving, the product should be handled carefully and lightly. Violent vibration and collision are strictly prohibited in order to avoid damage to the shell or internal electronic components.



SAFETY PRECAUTIONS

POWER SUPPLY

This product can be powered by standard indoor wall sockets. Please only use the power cord specified in this product. When not in use, please turn off the power supply. When not in use for a long time, pull out the power cord and keep it properly.

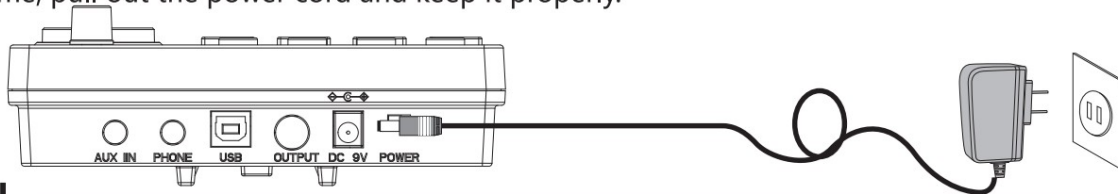

SIGN

To ensure that you use this product safely and correctly, to prevent harm to users and others and financial damage, this manual and products are marked with a series of safety signs. The various signs and their meanings are as follows:

WARNING

This sign indicates that there is a potential risk of death or serious injury if this mark is ignored and the product is mishandled.

BE CAREFUL

This sign indicates that there is a potential danger of injury to personnel or other financial damage if this sign is ignored and the product is operated incorrectly.

EXAMPLE OF LOGO



This triangle sign (Δ) indicates what users should pay attention to. (The left example is careful shocks)



A circular sign (\ominus) with an oblique line indicates prohibitions. The icons in or beside the logo indicate the contents specifically prohibited. (The example on the left is no disassembly)



The round black bottom sign (\odot) indicates what must be observed. The diagrams in this sign indicate the contents of the specific matters that must be observed. (The example on the left is that the power plug must be pulled out of the socket)



SAFETY PRECAUTIONS

WARNING

Smoke, odor, overheating

When the product smokes, smells or overheats, there is a danger of fire and electric shock when it is used continually. In case of the above situation, the following operations should be performed immediately:

1. Turn off the power supply.
2. Pull the plug out of the power outlet.
3. Contact your dealer.

Power cord

1. The improper use of power cord may cause fire and electric shock. The following precautions must be observed:

- The special power cord designated for this product must be used.
- The AC power supply with output voltage within the rated voltage range for household use must be used.
- Do not overload power sockets and extension lines.



2. The improper treatment of power line will lead to its damage or breakage, which will cause fire and electric shock hazards. The following precautions must be observed:

- Do not place or heat heavy objects on power lines.
- Do not attempt to alter or bend the power cord too much.
- Do not twist or pull the power cord.
- If the power cord or plug is damaged, please replace the same type of power cord.



3. Do not touch the power cord and plug with wet hands, otherwise there is a danger of electric shock.



4. Please use the power cord where the water will not splash. Water is in danger of causing fire and electric shock.



5. Never place vases or any other container containing water on this product. Water is dangerous of causing fire and electric shock.



6. Do not allow minors to unplug and touch power lines or connection boards. Minors have no common sense of electricity safety, which may cause electric shock.



BE CAREFUL

The improper use of power cord may cause fire and electric shock. The following precautions must be observed:

- Never put the power cord near the oven or other heat source.
- Do not pull the cable when pulling out of the power socket. The main body of the plug must be grasped.
- The power cord plug must be inserted in the socket to the end.
- Make sure the power supply is off before connecting or disconnecting it.
- When thunderstorms occur or before traveling or other long-term departure, disconnect the power cord from the wall outlet.
- At least once a year, remove the power cord from the wall outlet and clean the dust accumulated around the plug.



Do not burn this product

Do not put this product in the fire, otherwise it will lead to product combustion and explosion of internal electronic components, which will cause fire and personnel injury.



Water and foreign bodies

Water, other liquids and (metal sheets, etc.) entering this product are in danger of causing fire and electric shock. In case of the above situation, the following operations shall be performed immediately:

1. Turn off the power supply.
2. If you are using a power cord for power supply, unplug it from the wall outlet.
3. Contact your distributor.



Disassembly and transformation

Do not disassemble or transform the product in any way, otherwise there is a risk of electric shock, scald or other personal injury. All internal inspection, adjustment and maintenance operations should be entrusted to your distributor.





SAFETY PRECAUTIONS

Falling or colliding

If the product falls or is damaged by strong impact, it will be in danger of causing fire and electric shock. In case of the above situation, the following operations shall be performed immediately:

1. Turn off the power supply.
2. If you are using a power cord for power supply, you need to unplug it from the wall outlet.
3. Contact your distributor.



Plastic bag

Do not let anyone put plastic bags for this product on his head or in his mouth. Otherwise, there is a risk of asphyxia. Families with young children should pay special attention to it.



Keep a distance from the product and the bracket

Climbing the bracket is dangerous of overturning or damage. Families with young children should pay special attention to it.



Put

Avoid placing the product on an uneven surface or any other unstable place. Otherwise, it will cause the product to fall down, which will lead to the risk of injury.



Product Mobility

Before moving this product, you must unplug the power cord plug from the wall outlet and pull out all other cables and connecting wires. Otherwise, it will lead to damage of power or connection wires, resulting in fire and electric shock.



clean

Before cleaning this product, you must unplug the power cord plug from the wall outlet, otherwise there is a risk of fire and electric shock.



Jack

The socket of this product can only be connected to the designated equipment and devices. Connecting non-designated equipment or devices is dangerous of causing fire and electric shock.



Location selection

It should be avoided to place the product in the following places, otherwise there is a risk of fire and electric shock.

- High temperature or dusty places.
- Kitchen or other places with lampblack.
- Where the product is exposed to direct sunlight, or any other place where the product will produce high temperature.



Volume

Don't play music long and loud. Pay special attention when using headphones. Excessive volume can damage your hearing.



Heavy



Do not place heavy objects on this product. Otherwise, the top of the product will be overweight, causing the product to overturn or drop objects on it, which will lead to the risk of injury.



Correct assembly of scaffolds

The incorrect assembly of the bracket may overturn, causing the product to fall off and posing a risk of injury to personnel. Therefore, it must be assembled according to the instructions in the attached installation guide to ensure that the product is properly mounted on its bracket.



| | |
|--|---|
|  | <p>Avvertenza: per ridurre il rischio di lesioni, l'utente deve leggere attentamente il manuale di istruzioni.</p> |
|  | <p>Questo dispositivo è conforme alla Parte 15 delle norme FCC. Il funzionamento è soggetto alle seguenti due condizioni: (1) Questo dispositivo non può causare interferenze dannose e (2) questo dispositivo deve accettare qualsiasi interferenza ricevuta, comprese le interferenze che potrebbero causare un funzionamento indesiderato.</p> |
|  | <p>Questo prodotto è soggetto alle disposizioni della Direttiva Europea 2012/19/CE. Il simbolo del bidone della spazzatura barrato indica che nell'Unione Europea il prodotto richiede la raccolta differenziata dei rifiuti. Ciò vale per il prodotto e tutti gli accessori contrassegnati da questo simbolo. I prodotti contrassegnati come tali non possono essere smaltiti con i normali rifiuti domestici, ma devono essere portati in un punto di raccolta per il riciclaggio di dispositivi elettrici ed elettronici</p> |

Produttore: Shanghaimuxinmuyeyouxiangongsi

Indirizzo: Shuangchenglu 803nong11hao1602A-1609shi, baoshanqu, shanghai 200000 CN.

Importato in AUS: SIHAO PTY LTD, 1 ROKEVA STREETEASTWOOD NSW 2122Australia

Importato negli Stati Uniti: Sanven Technology Ltd., Suite 250, 9166 Anaheim Place, Rancho Cucamonga, CA 91730



E-CrossStu GmbH
Mainzer Landstr.69, 60329 Francoforte sul Meno.

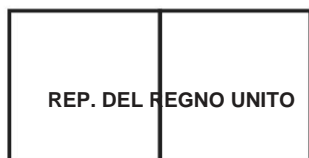

YH CONSULENZA LIMITATA.
C/O YH Consulting Limited Ufficio 147, Centurion House,
London Road, Staines-upon-Thames, Surrey, TW18 4AX

VEVOR®

TOUGH TOOLS, HALF PRICE

**Supporto tecnico e certificato di garanzia
elettronica www.vevor.com/support**

VEVOR[®]

TOUGH TOOLS, HALF PRICE

Soporte técnico y certificado de garantía

electrónica www.vevor.com/support

BATERÍA ELECTRÓNICA

MANUAL DE USUARIO

MODELO: MD200C

Seguimos comprometidos a proporcionarle herramientas a precios competitivos.

"Ahorre a mitad de precio", "A mitad de precio" o cualquier otra expresión similar utilizada por nosotros solo representa una estimación de los ahorros que podría beneficiarse al comprar ciertas herramientas con nosotros en comparación con las principales marcas principales y no significa necesariamente que cubra todas las categorías de herramientas. ofrecido por nosotros. Le recordamos que, cuando realice un pedido con nosotros, verifique cuidadosamente si realmente está ahorrando la mitad en comparación con las principales marcas.

VEVOR[®]
TOUGH TOOLS, HALF PRICE

BATERÍA ELECTRÓNICA

MODELO: MD200C

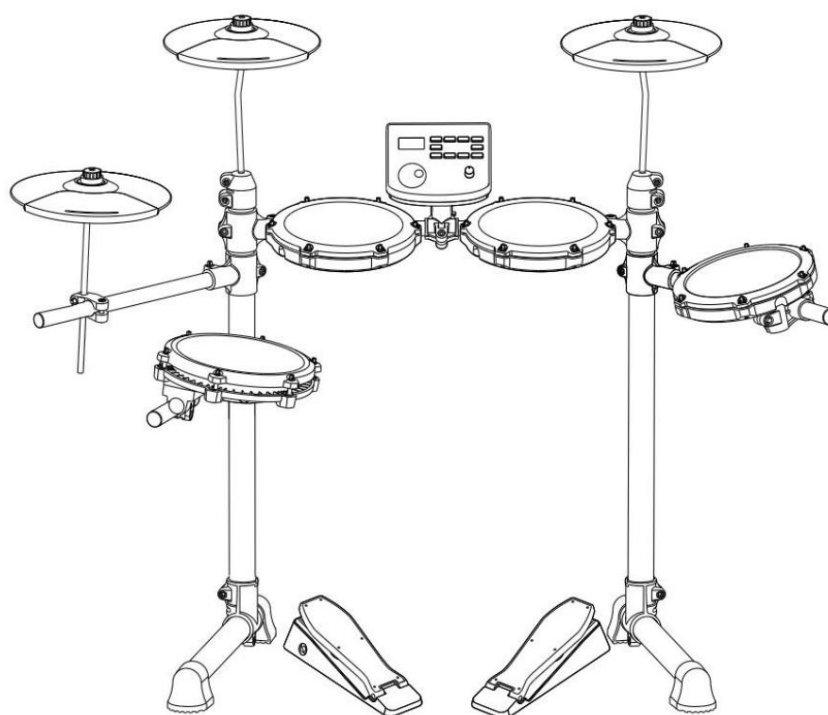

(La imagen es solo de referencia, consulte el objeto real)

¿NECESITAS AYUDA? ¡CONTÁCTENOS!

¿Tiene preguntas sobre el producto? ¿Necesita soporte técnico? Por favor, siéntase libre de contáctenos:

Soporte Técnico y Certificado de Garantía Electrónica

www.vevor.com/support

Estas son las instrucciones originales; lea atentamente todas las instrucciones del manual antes de operar. VEVOR se reserva una interpretación clara de nuestro manual de usuario. La apariencia del producto estará sujeta al producto que recibió. Perdón que no le informaremos nuevamente si hay actualizaciones de tecnología o software en nuestro producto.



INTRODUCCIÓN A LA FUNCIÓN

Gracias por elegir nuestra batería electrónica. El tambor electrónico elegante y delicado es la combinación perfecta de nueva tecnología electrónica moderna. •Antes de utilizar este producto, debe leer detalladamente las instrucciones.

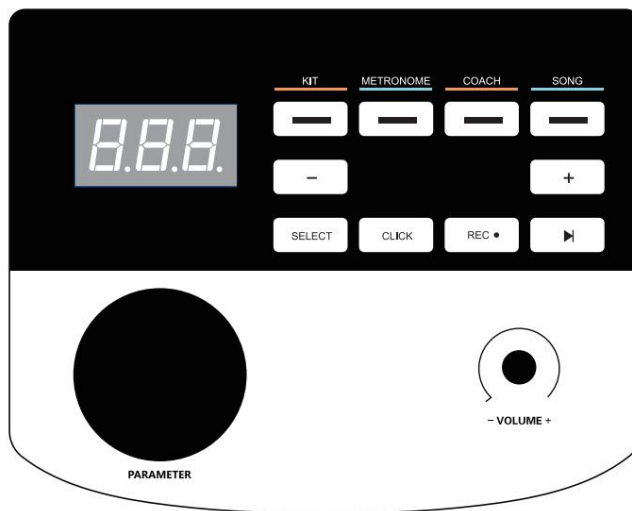

- 15 kits de batería, 180 timbres

- 30

canciones • admite el ajuste de los parámetros de sensibilidad de cada tambor

- tres modos de enseñanza

- control de velocidad: 30 ~ 250 latidos / min

- metrónomo: 1-9 tipos • otras

funciones: almacenamiento de parámetros, reinicio y grabación; •

pantalla LED de tres dígitos; •

interfaz: fuente de alimentación CC, usbmidi, auriculares, entrada de audio, salida de audio

para aumentar el platillo

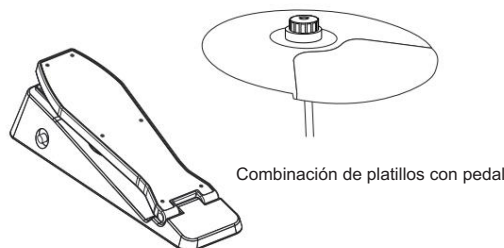

¡OBSERVACIÓN!

- Este producto es un instrumento electroacústico. Es normal que haya un poco de corriente.

sonido en el altavoz o auricular después del encendido.

Manténgalo alejado de "radio, TV, receptor de antena, enrutador, refrigerador, TV, motor y otras fuentes de interferencia eléctrica de RF" durante el uso.



CONTENIDO

| | |
|---|----|
| INTRODUCCIÓN A LA FUNCIÓN | 1 |
| CONTENIDO | 2 |
| GUÍA DE INSTALACIÓN | 3 |
| COMPRUEBE LOS ARTÍCULOS ADJUNTOS | 3 |
| MONTAJE DE TUBERÍA DE SOPORTE | 4 |
| SOPORTE DE MONTAJE | 4 |
| INSTALACIÓN DEL BANDEJA DE TAMBOR | 5 |
| INSTALACIÓN DEL MÓDULO DE SONIDO | 5 |
| INSTALAR PLATILLOS, MÓDULO DE SONIDO, COLOCAR PEDALES | 6 |
| INSERTAR EL CABLE DE CONEXIÓN DE LA PARTE DE GOLPEO | 7 |
| ILUSTRACIÓN DEL PUERTO DEL MÓDULO DE SONIDO | 8 |
| CONEXIÓN DEL CABLE DE ALIMENTACIÓN | 8 |
| PUERTO USB MIDI | 8 |
| PUERTO DE SALIDA DE AUDIO | 8 |
| PUERTO DE ENTRADA DE AUDIO | 8 |
| PUERTO PARA AURICULARES | 8 |
| MANUAL DE OPERACIONES | 9 |
| FUERZA | 9 |
| SELECCIÓN DEL KIT DE BATERÍA | 9 |
| METRÓNOMO | 9 |
| FUNCIÓN DE PRÁCTICA | 9 |
| MODO ENTRENADOR | 9 |
| CANCIÓN DE DEMOSTRACIÓN | 10 |
| PARÁMETROS DEL TAMBOR | 10 |
| FUNCIÓN DE GRABACIÓN | 10 |
| GUARDAR/RESETABLECER | 10 |
| USBMIDI | 10 |
| APÉNDICE | 11 |
| TIMBRE DE TAMBOR | 11 |
| KITS DE BATERÍA PREAJUSTADOS | 11 |
| KITS DE BATERÍA DEFINIDOS POR EL USUARIO | 11 |
| CANCIÓN DE DEMOSTRACIÓN | 11 |
| MANTENIMIENTO DEL PRODUCTO | 12 |
| PRECAUCIONES DE SEGURIDAD | 13 |



GUÍA DE INSTALACIÓN

¡OBSERVACIÓN!

- Siga las instrucciones y lea atentamente las "precauciones de seguridad" del Manual del usuario. antes de usar.
- Este producto debe ser instalado por un adulto, no permita que un menor lo instale de forma independiente.

01

Consulta los elementos adjuntos

- Después de abrir el paquete, verifique inmediatamente si contiene todos los artículos. Si falta alguno, póngase en contacto con su distribuidor.

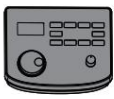

módulo de sonido



Soporte del módulo



Platillo*3



Tom (3 piezas)



Trampa



baqueta

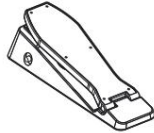

Pedales*2



Cable de conexión de señal



Adaptador de corriente

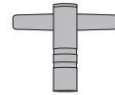

tecla de tambor



Brazo de suspensión/accidente



Brazo de charles



GUÍA DE INSTALACIÓN

02

Montaje de tubería de soporte

• El soporte se encuentra en un pequeño paquete individual dentro de la caja.

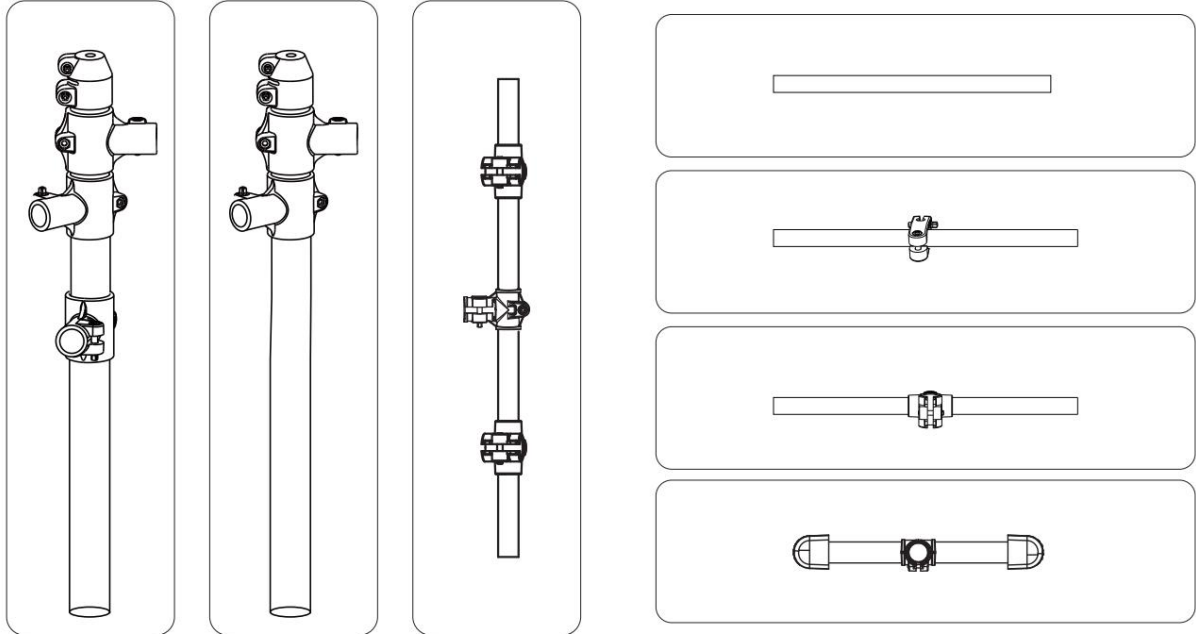

Soporte de montaje

03 • El soporte debe instalarse en su lugar y apretar los tornillos con la llave del tambor.

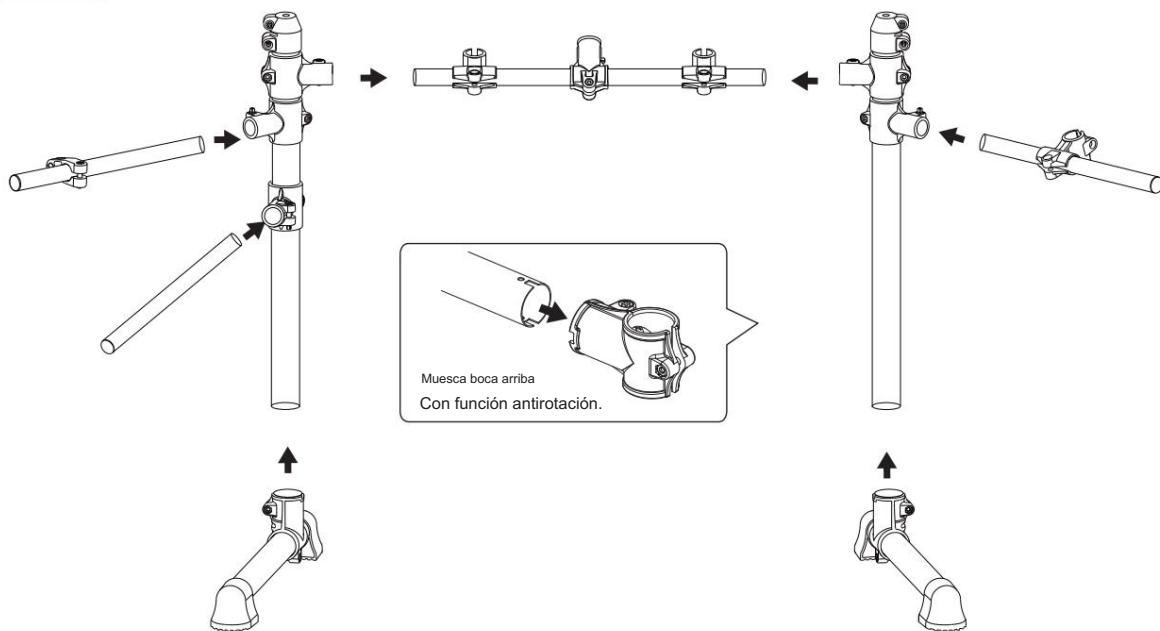



GUÍA DE INSTALACIÓN

04

Instalación del tambor

•Tenga cuidado y no se pellizque los dedos durante la instalación.

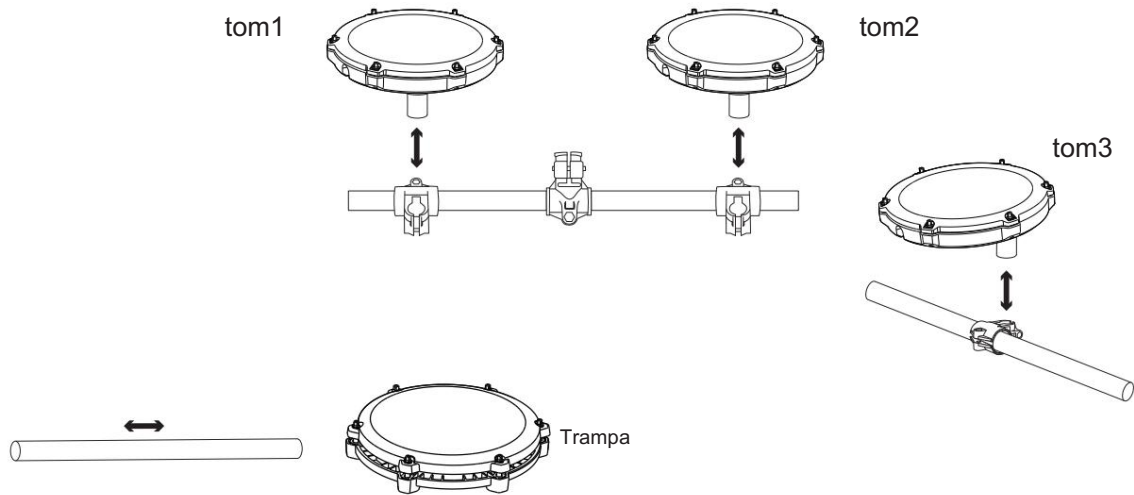

05

Instalación del módulo de sonido •

Ensamble el módulo de sonido con el soporte antes de colocarlo en la batería.

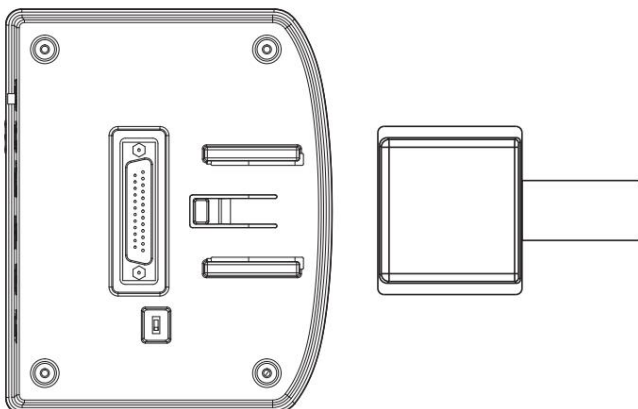

Inserte el soporte de la caja principal contra la pista del módulo de sonido y escuchará que aparece la pieza de clic cuando la inserte en la parte inferior.



06

Instalar platillos, módulo de sonido, colocar pedales.

- Asegúrese de no apretar demasiado el platillo, deje algo de espacio para que se muevan hacia arriba y hacia abajo.

Instale el platillo y el módulo de sonido en el soporte como se muestra en la imagen.

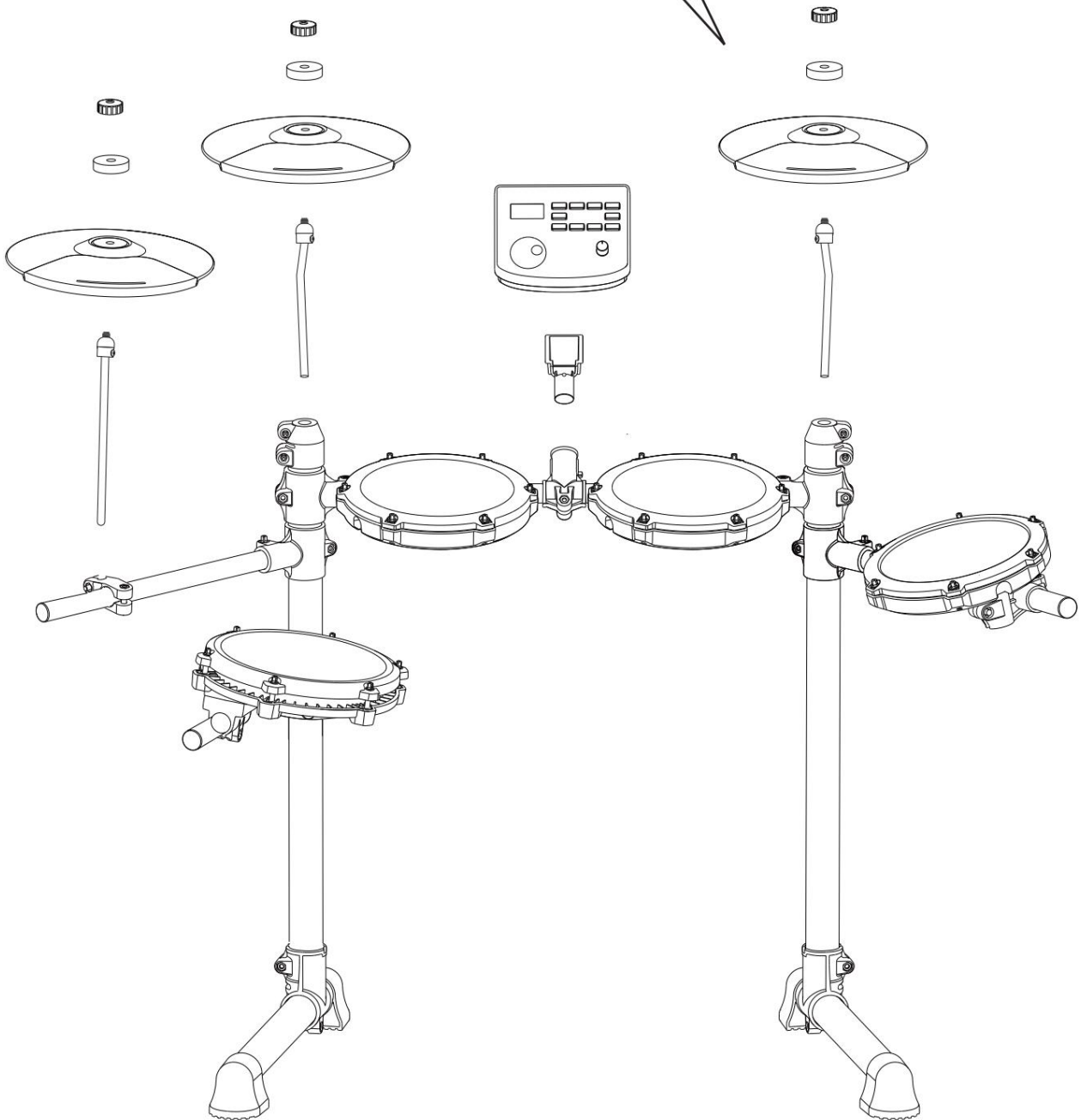
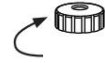



GUÍA DE INSTALACIÓN

07

Insertar el cable de conexión de la pieza de impacto.

•Inserte el cable de conexión en su lugar para evitar un mal contacto e insértelo correctamente como se muestra en el diagrama.





ILUSTRACIÓN DEL PUERTO DEL MÓDULO DE SONIDO

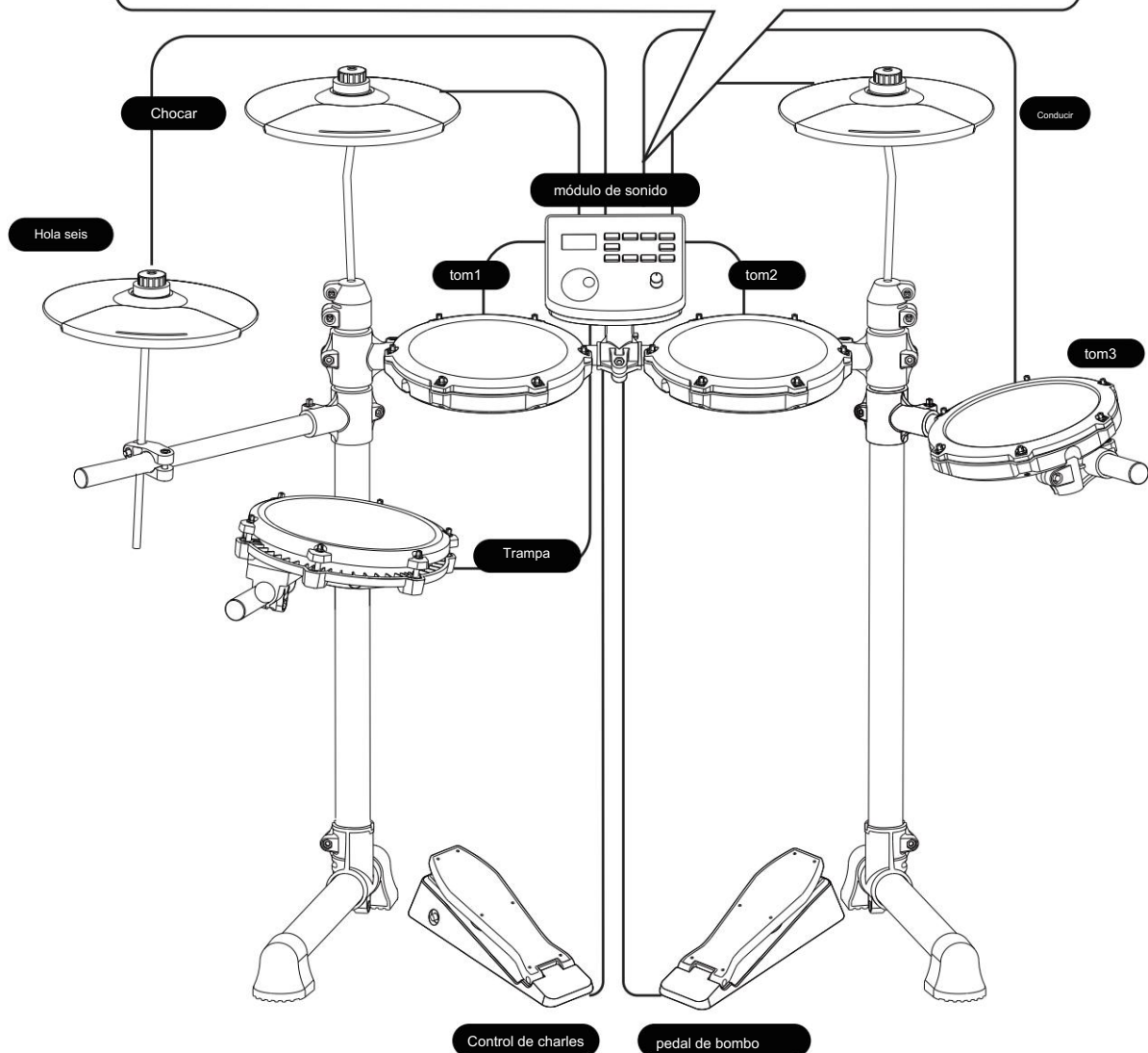
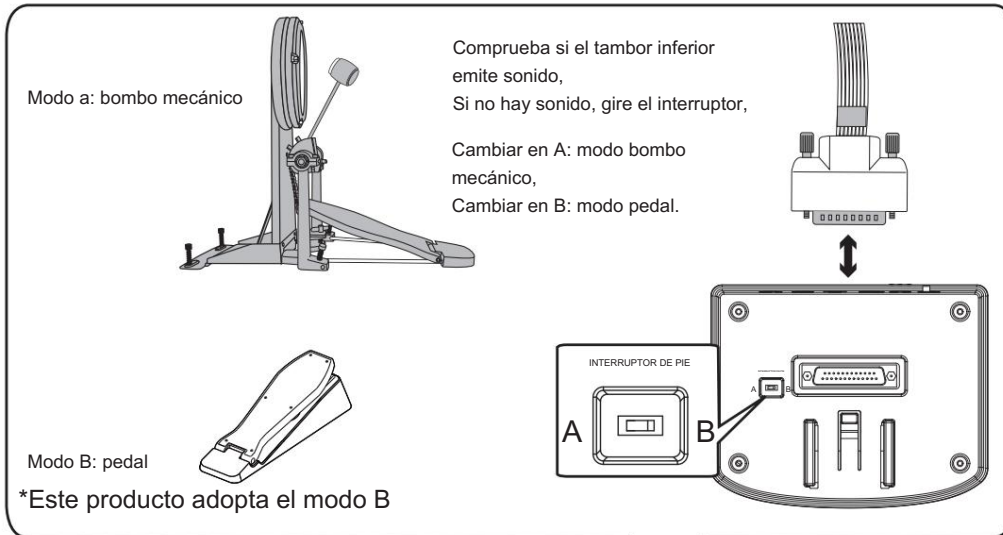
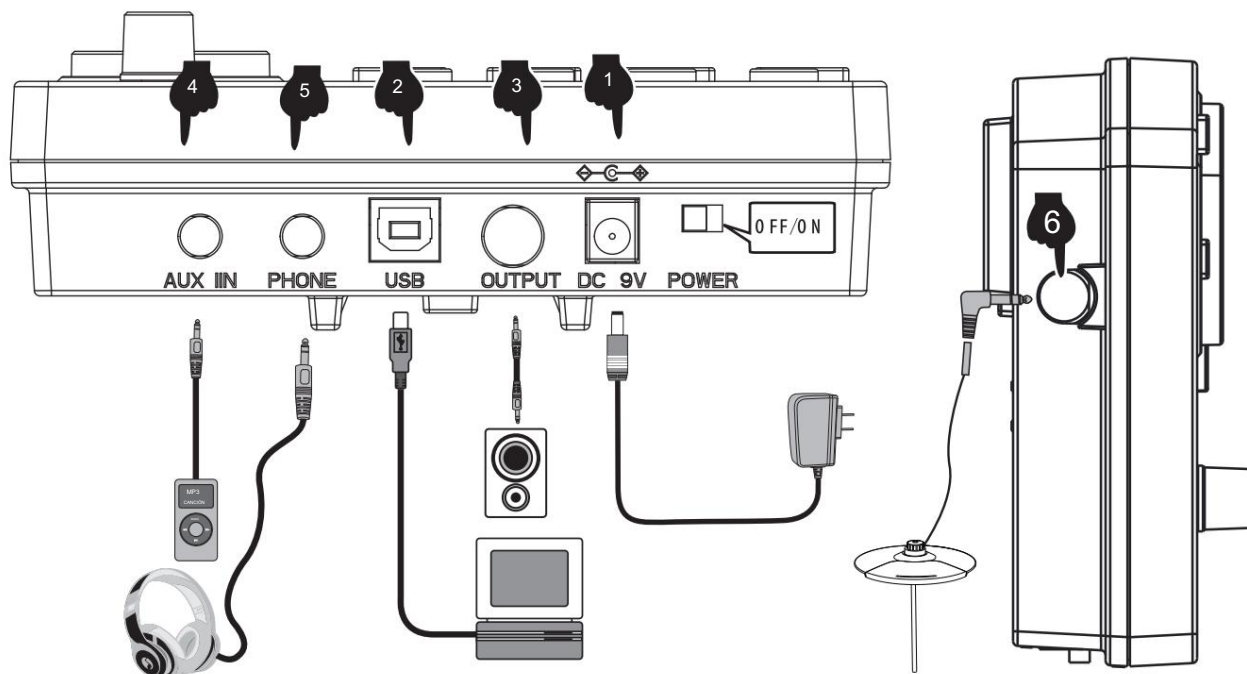

1 CONEXIÓN DEL CABLE DE ALIMENTACIÓN

1. Cuando esté en uso, conecte el terminal de alimentación de acuerdo con el diagrama, inserte la toma de corriente de la caja del módulo en un extremo y una toma de corriente doméstica de 100-240 V en el otro extremo. (Figura 1)
2. Si no utiliza este producto durante un período prolongado, desconecte el enchufe y manténgalo correctamente.

2 PUERTOS USB-MIDI

El uso de la interfaz USB MIDI de batería electrónica puede interactuar con dispositivos de música con MIDI.

1. A través del software de Música preinstalado en computadoras y teléfonos móviles, podemos aprender a tocar, componer música, tienda y otras funciones. (Figura 2)
2. Cuando se conecta a una computadora o teléfono móvil, la salida de audio del dispositivo debe estar conectada al audio toma de entrada del módulo de sonido para sincronizar los efectos de sonido en el dispositivo. (Figura 5)

3 PUERTOS DE SALIDA DE AUDIO

El puerto de salida de audio se puede conectar con un altavoz activo (altavoz de batería electrónica especial) y un equipo de audio grande. (Fig. 3)

4 PUERTOS DE ENTRADA DE AUDIO

El puerto de entrada de audio puede conectar el dispositivo de reproducción de fuente de sonido a la caja del módulo para su reproducción (como MP3, teléfono móvil y otras entradas de señal de audio). (Figura 4)

5 PUERTO PARA AURICULARES

La conexión de auriculares monitorea los detalles de la percusión y no molesta a los demás cuando tocas sin conectar altavoces. (Figura 5)

6 AUMENTAR PUERTO

Este puerto le permite agregar un platillo para una fácil expansión. (Figura 6)



MANUAL DE OPERACIONES

1 POTENCIA

Inserte el enchufe de CC en el puerto CC de 9 V en la parte superior del módulo de sonido. Deslice el interruptor POWER hacia la derecha (visto desde el frente) para encender la batería. Para apagar la batería, deslice el interruptor hacia la izquierda.

SELECCIÓN DE 2 BATERÍAS

Presione el botón KIT para mostrar el kit de batería actual. Gire la rueda de parámetros o utilice los botones <- /+> para seleccionar el kit de batería deseado. Hay 15 kits de batería para elegir; consulte la lista de kits de batería en la página 11.

3 METRÓNOMO

1. Presione el botón METRONOME para ingresar al modo metrónomo.
2. La pantalla mostrará el valor de velocidad (velocidad predeterminada de 120 BPM). Gire la rueda de parámetros o utilice el botón +/- botones para cambiar la velocidad del metrónomo. Presione el botón CLICK para iniciar el metrónomo.
3. Presione el botón SELECT en el modo metrónomo y la pantalla saltará al parámetro del metrónomo.
Interfaz de ajuste. Puede presionar los botones +/- para seleccionar el parámetro que desea ajustar:
 - A. r (tipo de ritmo: 2,4,8,16)
 - B. b (número de tiempo: 01-09)
 - C. L (volumen del metrónomo: 00 (apagado) -31) y luego gire la rueda de parámetros para ajustar la configuración de los parámetros.
4. Una vez ajustados los parámetros, presione el botón SELECT para confirmar y salir del parámetro.
interfaz. Luego
5. Utilice el botón de clic para iniciar y detener el metrónomo como desee.

4 FUNCIÓN DE PRÁCTICA

El modo entrenador "entrenador" de este producto puede ayudar a establecer velocidad, precisión y resistencia, y ayudar a cultivar el Practicar la función de un mejor sentido del ritmo. ¡Avanza bajo la supervisión del modo entrenador "entrenador"!

Presione el botón "entrenador" para ingresar al modo entrenador. En este modo, hay tres modos de práctica. Selecciona la practica modo a través de la rueda de datos o el botón <+ > <- >.

1. Modo de ejercicio 1: Ejercicio de detección de ritmo C-1: golpea el tambor a una velocidad fija para entrenar la precisión del golpe.
2. Modo de práctica 2: Modo de golpe silencioso C-2: el metrónomo hará sonar una sección y silenciará una sección para entrenar el Precisión del golpe sin aviso de metrónomo. Es una versión avanzada del modo de práctica 1.
3. Modo de práctica 3: práctica de golpe de velocidad C-3, el metrónomo cambiará automáticamente la velocidad, aumentará desde el expreso más lento al más rápido, y luego reduzca del expreso más lento a la velocidad más lenta, para practicar el resistencia al golpe.

5 MODO ENTRENADOR

1. El modo de entrenamiento "entrenador" de este producto puede ayudar a establecer velocidad, precisión y resistencia. Presione el botón COACH para ingresar al modo entrenador. En este modo, hay tres modos de práctica. Utilice la rueda de parámetros para seleccionar qué modo de práctica.
 - A. Modo de ejercicio 1: Ejercicio de detección de ritmo C-1: golpee el tambor a una velocidad fija para entrenar la precisión del golpe.
 - B. Modo de práctica 2: modo de golpe silencioso C-2: el metrónomo sonará en una sección y silenciará una sección para entrenar.
cuando no hay ritmo.
 - C. Modo de práctica 3: Práctica de golpe de velocidad C-3: el metrónomo cambiará automáticamente la velocidad desde la más lenta al más rápido y luego del más rápido al más lento.
2. Una vez elegido el modo de entrenamiento, presione el botón CLIC. Los ritmos del metrónomo comenzarán y podrás
Toque el tambor para practicar.
3. Después de cuatro latidos preliminares, la pantalla mostrará:



MANUAL DE OPERACIONES

(demasiado lento)



(bien)



(demasiado rapido)



4. Una vez que haya completado el modo de entrenamiento, se mostrará una puntuación de 0 a 100 que evalúa la precisión de el ejercicio.

Modo C-1: Presione el botón SELECT para ingresar a la interfaz de configuración de parámetros. Puedes ajustar el número de prácticas. sesiones según sea necesario (01-32). El número de sesiones a practicar determina la duración de este ejercicio.

Modo C-2: Presione el botón SELECT para ingresar a la interfaz de configuración de parámetros. Puedes ajustar el número de prácticas. sesiones según sea necesario (04-32). El número de sesiones a practicar determina la duración de este ejercicio.

Modo C-3: Presione el botón SELECT para ingresar a la interfaz de configuración de parámetros. Puede ajustar la velocidad a la que se reproducen los BPM. cambios (01-09 BPM).

5. Presione el botón CLICK nuevamente para finalizar el modo entrenador.

6 CANCIONES DE DEMOSTRACIÓN

1. Presione el botón SONG para ingresar al modo de demostración, hay 30 demostraciones para elegir. La pantalla mostrará el número de canción de demostración actual (01 -30).
2. Presione el botón >▶ para comenzar a reproducir las canciones de demostración. Para detener la reproducción presione el botón << nuevamente.
3. Gire la rueda de parámetros o presione los botones +/- para seleccionar una canción de demostración.
4. Presione el botón SELECT en el modo de canción para saltar a la interfaz de configuración de parámetros de la canción. Puede activar el sonido del tambor. activar o desactivar girando la rueda de parámetros (el sonido de batería está activado de forma predeterminada).
5. Presione el botón SELECCIONAR para confirmar y salir de la interfaz de parámetros.

7 PARÁMETROS DEL TAMBOR

1. Presione el botón KIT y la pantalla mostrará 01 (número del kit de batería). Presione SELECT para ingresar el parámetro de batería. modo de ajuste.
2. Toque el tambor que desea ajustar y luego presione los botones +/- para seleccionar el parámetro a ajustar. Sensibilidad S (01-06). Umbral de disparo t (01 - 32). Umbral de diafonía c (01 -32) Disparador repetido r (01-32) Drum Force V (01-03). Volumen del tambor L (00 - 31).
3. Cambie los parámetros girando la rueda de parámetros y mantenga presionado el botón - para guardar. La pantalla con display. SAV para indicar que el ajuste del parámetro se ha guardado correctamente.
4. Para restaurar los parámetros del tambor a la configuración de fábrica, mantenga presionado el botón + hasta que la pantalla muestre RES.POR FAVOR.

NOTA: Los parámetros para los 3 toms no se pueden configurar individualmente.

8 FUNCIÓN DE GRABACIÓN

1. Presione el botón <REC> cuando la luz indicadora esté en los estados "KIT" y "CLICK" y la pantalla muestre el palabras "REC" en el estado de respiración intermitente, ingresando al estado de preparación de grabación.
2. Toca cualquier tambor y suena el metrónomo. En este momento, la pantalla muestra "---" en el estado de respiración parpadeante. y comienza a grabar.
3. Presione la tecla < REC > o < PLAY > nuevamente, la grabación se detiene y se muestra "A-1" en la pantalla.
4. Presione < ▶ | > para comenzar a reproducir la grabación actual y presione nuevamente para detener la reproducción.
5. Si ingresa nuevamente al estado de preparación de grabación sin tocar, se reproducirá el "A-1" grabado la última vez.

9 GUARDAR / RESTABLECER

1. Para guardar los parámetros, mantenga presionado el botón <-> y la pantalla mostrará SAV.
2. Para restablecer los parámetros, mantenga presionado el botón <+> y la pantalla mostrará RES res.

10 USBMIDI

Para utilizar la función MID de los kits de batería, conecte un cable de datos USB-B (no incluido con este kit de batería) a la unidad de control y conectarse a la PC/teléfono inteligente.



APPENDIX

Timbre

| | | | |
|---------------------------------|-------------------------------|------------------------------|---------------------------------------|
| Patada | 39 . Borde de caja de jazz | 78 . pop rock tom3 | 116 . Choque popular2 |
| 1 . patada funk | 40 . Borde de caja de blues | 79 . Roca Tom3 | 117 . Accidente de fusible2 |
| 2 . Patada original | 41 . Borde de caja popular | 80 . Sesión Tom3 | 118 . Choque de dancehall2 |
| 3 . Patada de poprock | 42 . Borde de caja fusible | 81 . SpeedMetal Tom3 | 119 . Crash2 de mirada sintetizada |
| 4 . Patada de roca | 43 . Borde de caja dancehall | 82 . ClásicoDry Tom3 | 120 . Choque estándar2 |
| 5 . Patada de sesión | 44 . Borde de caja Synthgaze | 83 . Tom3 moderno | Conducir |
| 6 . Patada de metal rápido | 45 . Borde de caja estándar | 84 . jazz tom3 | 121 . Paseo funk |
| 7 . Patada seca clásica | Tomás | 85 . blues tom3 | 122 . Paseo original |
| 8vo. patada moderna | 46 . funk tom1 | 86 . Tom3 popular | 123 . Paseo pop-rock |
| 9 . Patada de jazz | 47 . Tom1 original | 87 . Fusible Tom3 | 124 . Paseo en roca |
| 10 . Patada de blues | 48 . pop-rock-tom1 | 88 . Dancehall Tom3 | 125 . Paseo de la sesión |
| 11 . Patada Popular | 49 . Roca Tom1 | 89 . Synthgaze Tom3 | 126 . Paseo SpeedMetal |
| 12 . Patada de fusible | 50 . Sesión Tom1 | 90 . Tom3 estándar | 127 . Paseo en seco clásico |
| 13 . Patada de baile | 51 . SpeedMetal Tom1 | Chocar | 128 . Paseo moderno |
| 14 . Patada de mirada sintética | 52 . ClásicoDry Tom1 | 91 . Choque funk1 | 129 . Paseo de jazz |
| 15 . Patada estándar | 53 . Tom1 moderno | 92 . Accidente original1 | 130 . Paseo de blues |
| Trampa | 54 . jazz tom1 | 93 . Choque de pop rock1 | 131 . Paseo popular |
| dieciséis . Caja funk | 55 . blues tom1 | 94 . Choque de roca1 | 132 . Paseo en fusible |
| 17 . Caja original | 56 . Popular Tom1 | 95 . Accidente de sesión1 | 133 . Paseo en salón de baile |
| 18 . Caja pop rock | 57 . Fusible Tom1 | 96 . Choque de SpeedMetal1 | 134 . Paseo Synthgaze |
| 19 . trampa de roca | 58 . Dancehall Tom1 | 97 . ClásicoDry Crash1 | 135 . Paseo estándar |
| 20 . Trampa de sesion | 59 . Sintetizada Tom1 | 98 . Accidente moderno1 | Hola sombrero |
| 21 . Caja SpeedMetal | 60 . Tom1 estándar | 99 . Choque de jazz1 | 136 . Funk charles abierto |
| 22 . Trampa seca clásica | 61 . funk tom2 | 100 . Choque de blues1 | 137 . Charles original abierto |
| 23 . trampa moderna | 62 . tom2 originales | 101 . Accidente popular1 | 138 . Pop Rock Charles Abierto |
| 24 . Caja de jazz | 63 . pop rock tom2 | 102 . Accidente de fusible1 | 139 . Abierto de charles de rock |
| 25 . Caja de blues | 64 . Roca Tom2 | 103 . Choque de dancehall1 | 140 . Seesion charles abierto |
| 26 . Trampa popular | sesenta y cinco . Sesión Tom2 | 104 . Accidente de síntesis1 | 141 . Charles SpeedMetal abierto |
| 27 . Trampa de fusibles | 66 . SpeedMetal Tom2 | 105 . Accidente estándar1 | 142 . ClassicDry Hi-Hat abierto |
| 28 . Caja de baile | 67 . ClásicoDry Tom2 | 106 . Choque funk2 | 143 . Charles moderno abierto |
| 29 . Trampa de mirada sintética | 68 . Tom2 moderno | 107 . Choque original2 | 144 . Abierto de charles de jazz |
| 30 . Caja estándar | 69 . jazz tom2 | 108 . Choque de poprock2 | 145 . Charles de blues abierto |
| 31 . Borde de caja Funk | 70 . blues tom2 | 109 . Choque de roca2 | 146 . Abierto de charles popular |
| 32 . Borde de caja original | 71 . Tom2 popular | 110 . Accidente de sesión2 | 147 . Fusible charles abierto |
| 33 . Rima de trampa pop rock | 72 . Fusible Tom2 | 111 . SpeedMetal Crash2 | 148 . Abierto de charles de dancehall |
| 34 . Borde de caja de roca | 73 . Dancehall Tom2 | 112 . ClásicoDry Crash2 | 149 . Charles Synthgaze abierto |
| 35 . Borde de caja Seesion | 74 . Synthgaze Tom2 | 113 . Choque moderno2 | 150 . Charles estándar abierto |
| 36 . Borde de caja SpeedMetal | 75 . Tom2 estándar | 114 . Choque de jazz2 | 151 . Funk Hi-Hat Cerrar |
| 37 . Borde de caja seco clásico | 76 . funk tom3 | 115 . Choque de blues2 | 152 . Cerrar charles original |
| 38 . Borde de caja moderno | 77 . Tom3 originales | | |



APPENDIX

| | | |
|---------------------------------|-----------------------------------|----------------------------------|
| 153 . Charles Poprock Cerrar | 163 . Charles Dancehall Cerrar | 173. Pedal de charles moderno |
| 154 . Charles de rock Cerrar | 164 . Cerrar charles Synthgaze | 174 . Pedal de charles de jazz |
| 155 . Seesion Hi-Hat Cerrar | 165 . Cierre de charles estándar | 175 . Pedal de charles de blues |
| 156 . Charles SpeedMetal Cerrar | 166 . Pedal de charles Funk | 176 . Pedal de charles popular |
| 157 . ClassicDry Hi-Hat Cerrar | 167 . Pedal de charles original | 177 . Pedal de charles fusible |
| 158 . Hi-Hat moderno Cerrar | 168 . Pedal de charles pop rock | 178 . Pedal de charles Dancehall |
| 159 . Charles de Jazz Cerrar | 169 . Pedal de charles de rock | 179 . Pedal de charles Synthgaze |
| 160 . Charles de blues Cerrar | 170 . Pedal de charles Seesion | 180. Pedal de charles estándar |
| 161 . Cierre de charles popular | 171 . Pedal de charles SpeedMetal | |
| 162 . Fusible Hi-Hat Cerrar | 172 . Pedal de charles ClassicDry | |

Drum combination timbre

Batería de usuario

| | | | | |
|-------------|---------------|---------------|------------|--------------|
| 01 Funk | 04 Rock | 07 ClassicDry | 10 Blues | 13 Dancehall |
| 02 Original | 05 Seesion | 08 Modern | 11 Popular | 14 Synthgaze |
| 03 Poprock | 06 SpeedMetal | 09 Jazz | 12 Fuse | 15 Standard |

Canción de demostración

| | | | | | | | |
|-------------|-------------|-------------|-------------|-------------|-------------|-------------|-------------|
| Canción 001 | Canción 005 | Canción 009 | Canción 013 | Canción 017 | Canción 021 | Canción 025 | Canción 029 |
| Canción 002 | Canción 006 | Canción 010 | Canción 014 | Canción 018 | Canción 022 | Canción 026 | Canción 030 |
| Canción 003 | Canción 007 | Canción 011 | Canción 015 | Canción 019 | Canción 023 | Canción 027 | |
| Canción 004 | Canción 008 | Canción 012 | Canción 016 | Canción 020 | Canción 024 | Canción 028 | |



PRODUCT MAINTENANCE

Careful maintenance and protection of the product, to extend the service life of the product, reduce the fault has a very important role.

1 AVOID HEATING, DAMPNESS OR DIRECT SUNLIGHT

Do not over expose the product to direct sunlight, or place it near air conditioning or extremely hot place.

2 DO NOT USE NEAR THE TV OR RADIO

This product may cause video or audio interference to the reception of TV and radio. If this happens, the product should be removed from the TV or radio.

3 NO DILUENTS OR SIMILAR CHEMICALS SHOULD BE USED FOR CLEANING

Clean the product with a soft cloth wetted with weak water solution and neutral detergent. Soak the cloth in a solution and wring it dry until it approaches drying.

4 DO NOT SHAKE, AVOID COLLISION

When moving, the product should be handled carefully and lightly. Violent vibration and collision are strictly prohibited in order to avoid damage to the shell or internal electronic components.



SAFETY PRECAUTIONS

POWER SUPPLY

This product can be powered by standard indoor wall sockets. Please only use the power cord specified in this product. When not in use, please turn off the power supply. When not in use for a long time, pull out the power cord and keep it properly.

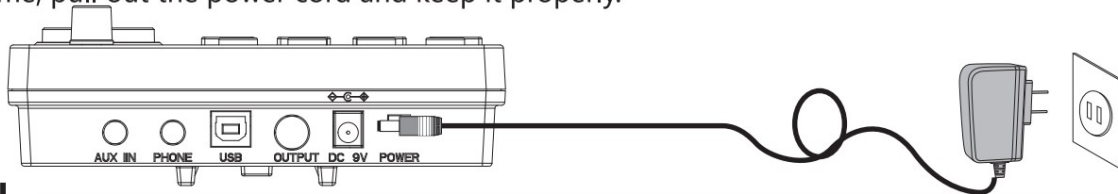

SIGN

To ensure that you use this product safely and correctly, to prevent harm to users and others and financial damage, this manual and products are marked with a series of safety signs. The various signs and their meanings are as follows:

WARNING

This sign indicates that there is a potential risk of death or serious injury if this mark is ignored and the product is mishandled.

BE CAREFUL

This sign indicates that there is a potential danger of injury to personnel or other financial damage if this sign is ignored and the product is operated incorrectly.

EXAMPLE OF LOGO



This triangle sign (Δ) indicates what users should pay attention to. (The left example is careful shocks)



A circular sign (\ominus) with an oblique line indicates prohibitions. The icons in or beside the logo indicate the contents specifically prohibited. (The example on the left is no disassembly)



The round black bottom sign (\odot) indicates what must be observed. The diagrams in this sign indicate the contents of the specific matters that must be observed. (The example on the left is that the power plug must be pulled out of the socket)



SAFETY PRECAUTIONS

WARNING

Smoke, odor, overheating

When the product smokes, smells or overheats, there is a danger of fire and electric shock when it is used continually. In case of the above situation, the following operations should be performed immediately:

1. Turn off the power supply.
2. Pull the plug out of the power outlet.
3. Contact your dealer.

Power cord

1. The improper use of power cord may cause fire and electric shock. The following precautions must be observed:

- The special power cord designated for this product must be used.
- The AC power supply with output voltage within the rated voltage range for household use must be used.
- Do not overload power sockets and extension lines.



2. The improper treatment of power line will lead to its damage or breakage, which will cause fire and electric shock hazards. The following precautions must be observed:

- Do not place or heat heavy objects on power lines.
- Do not attempt to alter or bend the power cord too much.
- Do not twist or pull the power cord.
- If the power cord or plug is damaged, please replace the same type of power cord.



3. Do not touch the power cord and plug with wet hands, otherwise there is a danger of electric shock.



4. Please use the power cord where the water will not splash. Water is in danger of causing fire and electric shock.



5. Never place vases or any other container containing water on this product. Water is dangerous of causing fire and electric shock.



6. Do not allow minors to unplug and touch power lines or connection boards. Minors have no common sense of electricity safety, which may cause electric shock.



BE CAREFUL

The improper use of power cord may cause fire and electric shock. The following precautions must be observed:

- Never put the power cord near the oven or other heat source.
- Do not pull the cable when pulling out of the power socket. The main body of the plug must be grasped.
- The power cord plug must be inserted in the socket to the end.
- Make sure the power supply is off before connecting or disconnecting it.
- When thunderstorms occur or before traveling or other long-term departure, disconnect the power cord from the wall outlet.
- At least once a year, remove the power cord from the wall outlet and clean the dust accumulated around the plug.



Do not burn this product

Do not put this product in the fire, otherwise it will lead to product combustion and explosion of internal electronic components, which will cause fire and personnel injury.



Water and foreign bodies

Water, other liquids and (metal sheets, etc.) entering this product are in danger of causing fire and electric shock. In case of the above situation, the following operations shall be performed immediately:



1. Turn off the power supply.
2. If you are using a power cord for power supply, unplug it from the wall outlet.
3. Contact your distributor.

Disassembly and transformation

Do not disassemble or transform the product in any way, otherwise there is a risk of electric shock, scald or other personal injury. All internal inspection, adjustment and maintenance operations should be entrusted to your distributor.





SAFETY PRECAUTIONS

Falling or colliding

If the product falls or is damaged by strong impact, it will be in danger of causing fire and electric shock. In case of the above situation, the following operations shall be performed immediately:

1. Turn off the power supply.
2. If you are using a power cord for power supply, you need to unplug it from the wall outlet.
3. Contact your distributor.



Plastic bag

Do not let anyone put plastic bags for this product on his head or in his mouth. Otherwise, there is a risk of asphyxia. Families with young children should pay special attention to it.



Keep a distance from the product and the bracket

Climbing the bracket is dangerous of overturning or damage. Families with young children should pay special attention to it.



Put

Avoid placing the product on an uneven surface or any other unstable place. Otherwise, it will cause the product to fall down, which will lead to the risk of injury.



Product Mobility

Before moving this product, you must unplug the power cord plug from the wall outlet and pull out all other cables and connecting wires. Otherwise, it will lead to damage of power or connection wires, resulting in fire and electric shock.



clean

Before cleaning this product, you must unplug the power cord plug from the wall outlet, otherwise there is a risk of fire and electric shock.



Jack

The socket of this product can only be connected to the designated equipment and devices. Connecting non-designated equipment or devices is dangerous of causing fire and electric shock.



Location selection

It should be avoided to place the product in the following places, otherwise there is a risk of fire and electric shock.

- High temperature or dusty places.
- Kitchen or other places with lampblack.
- Where the product is exposed to direct sunlight, or any other place where the product will produce high temperature.



Volume

Don't play music long and loud. Pay special attention when using headphones. Excessive volume can damage your hearing.



Heavy



Do not place heavy objects on this product. Otherwise, the top of the product will be overweight, causing the product to overturn or drop objects on it, which will lead to the risk of injury.



Correct assembly of scaffolds

The incorrect assembly of the bracket may overturn, causing the product to fall off and posing a risk of injury to personnel. Therefore, it must be assembled according to the instructions in the attached installation guide to ensure that the product is properly mounted on its bracket.



| | |
|--|--|
|  | <p>Advertencia: para reducir el riesgo de lesiones, el usuario debe leer atentamente el manual de instrucciones.</p> |
|  | <p>Este dispositivo cumple con la Parte 15 de las normas de la FCC. El funcionamiento está sujeto a las dos condiciones siguientes: (1) Este dispositivo no puede causar interferencias dañinas y (2) este dispositivo debe aceptar cualquier interferencia recibida, incluidas las interferencias que puedan causar un funcionamiento no deseado.</p> |
|  | <p>Este producto está sujeto a las disposiciones de la Directiva Europea 2012/19/CE. El símbolo que muestra un contenedor con ruedas tachado indica que el producto requiere recogida selectiva de basura en la Unión Europea. Esto se aplica al producto y a todos los accesorios marcados con este símbolo. Los productos marcados como tales no podrán desecharse con la basura doméstica normal, sino que deberán llevarse a un punto de recogida para el reciclaje de aparatos eléctricos y electrónicos.</p> |

Fabricante: Shanghaimuxinmuyeyouxiangongsi

Dirección: Shuangchenglu 803nong11hao1602A-1609shi, baoshanqu, shanghai 200000 CN.

Importado a AUS: SIHAO PTY LTD, 1 ROKEVA STREETEASTWOOD NSW 2122 Australia

Importado a EE. UU.: Sanven Technology Ltd., Suite 250, 9166 Anaheim Place, Rancho Cucamonga, CA 91730

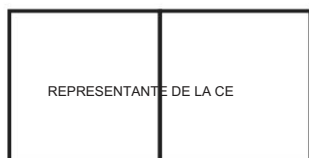

E-CrossStu GmbH
Mainzer Landstr.69, 60329 Fráncfort del Meno.

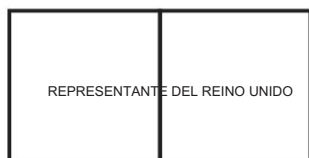

YH CONSULTING LIMITADO.
C/O YH Consulting Limited Oficina 147, Centurion House,
London Road, Staines upon Thames, Surrey, TW18 4AX

VEVOR[®]

TOUGH TOOLS, HALF PRICE

Soporte técnico y certificado de garantía
electrónica www.vevor.com/support

VEVOR[®]

TOUGH TOOLS, HALF PRICE

Wsparcie techniczne i certyfikat e-gwarancji
www.vevor.com/support

ELEKTRONICZNY ZESTAW PERKUSYJNY

INSTRUKCJA OBSŁUGI

MODEL: MD200C

Nadal dokładamy wszelkich starań, aby zapewnić Państwu narzędzia w konkurencyjnej cenie. „Zaoszczędź o połowę”, „o połowę ceny” lub inne podobne wyrażenia używane przez nas stanowią jedynie szacunkową kwotę oszczędności, jaką możesz zyskać kupując u nas określone narzędzia w porównaniu z głównymi, najlepszymi markami i niekoniecznie oznaczają objęcie wszystkich kategorii narzędzi oferowane przez nas. Przypominamy, abyś podczas składania zamówienia u nas dokładnie sprawdził, czy faktycznie oszczędzasz połowę w porównaniu z czołowymi markami.

VEVOR[®]
TOUGH TOOLS, HALF PRICE

ELEKTRONICZNY ZESTAW PERKUSYJNY

MODEL: MD200C 2

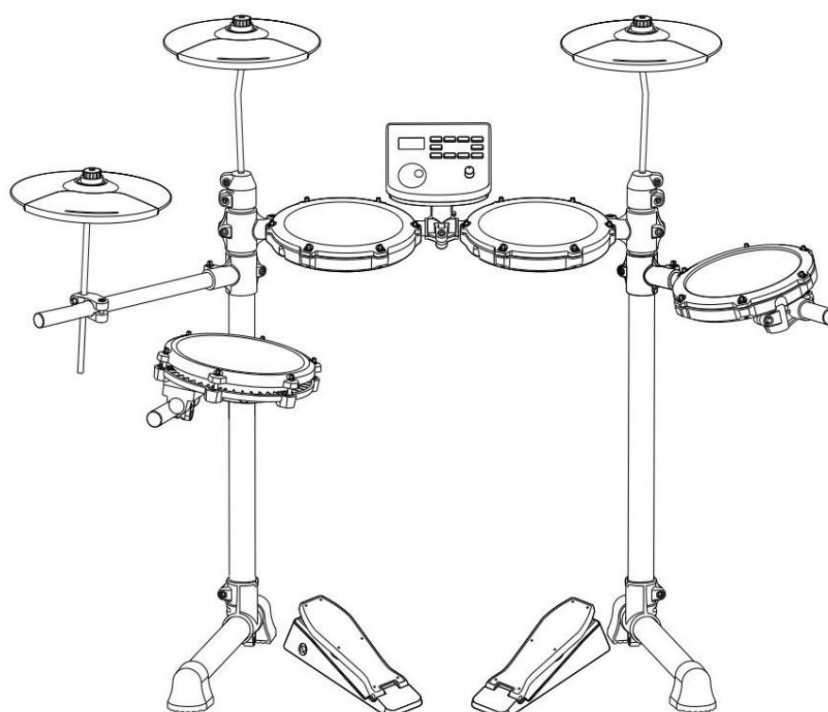

(Zdjęcie ma charakter wyłącznie poglądowy, proszę zapoznać się z rzeczywistym obiektem)

POTRZEBUJĘ POMOCY? SKONTAKTUJ SIĘ Z NAMII!

Masz pytania dotyczące produktu? Potrzebujesz wsparcia technicznego? Proszę, czuj się swobodnie by skontaktuj się

z nami: Wsparcie techniczne i certyfikat e-gwarancji [www.vevor.com/
support](http://www.vevor.com/support)

To jest oryginalna instrukcja. Przed przystąpieniem do obsługi prosimy o dokładne zapoznanie się ze wszystkimi instrukcjami. VEVOR zastrzega sobie jasną interpretację naszej instrukcji obsługi. Wygląd produktu zależy od produktu, który otrzymałeś. Proszę wybaczyć nam, że nie będziemy ponownie informować Państwa, jeśli pojawią się jakieś aktualizacje technologii lub oprogramowania naszego produktu.



WSTĘP FUNKCJI

Dziękujemy za wybranie naszego bębna elektronicznego. Elegancki i delikatny bęben elektroniczny to idealne połączenie nowoczesnej technologii elektronicznej. •Przed użyciem tego produktu należy szczegółowo przeczytać instrukcję.

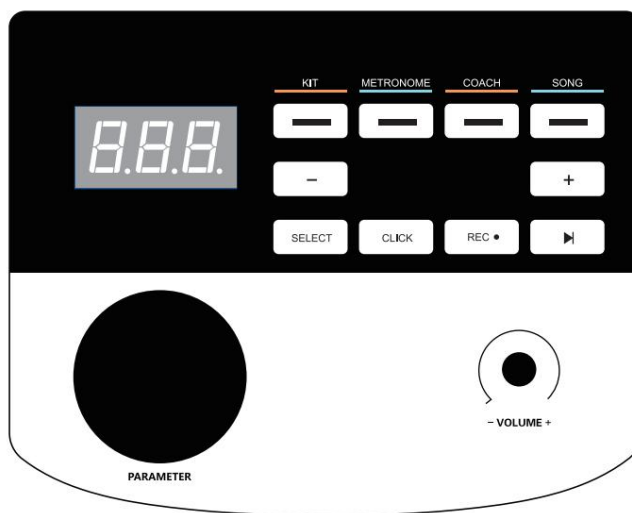

- 15 zestawów perkusyjnych, 180 barw

- 30

- utworów • możliwość regulacji parametrów czułości każdego bębna •

- trzy tryby uczenia •

- kontrola prędkości: 30 ~ 250 uderzeń/min

- metronom: 1-9 typów •

- inne funkcje: przechowywanie parametrów, resetowanie i

- nagrywanie; • trzycyfrowy

- wyświetlacz LED; • interfejs: zasilacz DC, usbmidi, słuchawki, wejście audio, wyjście

- audio zwiększające talerz

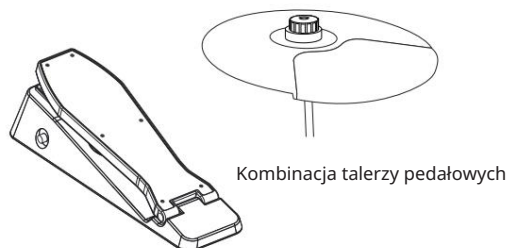

UWAGA!

- Ten produkt jest instrumentem elektroakustycznym. To normalne, że jest niewielki prąd dźwięk w głośniku lub słuchawkach po włączeniu zasilania.

Podczas użytkowania należy trzymać z dala od „radia, telewizora, odbiornika antenowego, routera, lodówki, telewizora, silnika i innych źródeł zakłóceń elektrycznych RF”.



ZAWARTOŚĆ

| | |
|--|----|
| WSTĘP FUNKCJI | 1 |
| SPIS TREŚCI | 2 |
| INSTRUKCJA INSTALACJI | 3 |
| SPRAWDŹ ZAŁĄCZONE ELEMENTY | 3 |
| ŁĄCZNIK RUR STOJAKOWYCH | 4 |
| STOJAK MONTAŻOWY | 4 |
| MONTAŻ MISKI BĘBNA | 5 |
| INSTALACJA MODUŁU DŹWIĘKOWEGO | 5 |
| ZAMONTUJ TALERZA, MODUŁ DŹWIĘKOWY, UMIEŚĆ PEDAŁY | 6 |
| WPROWADŹ KABEL ŁĄCZĄCY CZĘŚCI UDERZAJĄCEJ | 7 |
| ILUSTRACJA PORTU MODUŁU DŹWIĘKOWEGO | 8 |
| PODŁĄCZENIE PRZEWODU ZASILAJĄCEGO | 8 |
| PORT MIDI USB | 8 |
| PORT WYJŚCIA AUDIO | 8 |
| PORT WEJŚCIOWY AUDIO | 8 |
| PORT SŁUCHAWKOWY | 8 |
| PRZEWODNIK PO OPERACJACH | 9 |
| MOC | 9 |
| WYBÓR ZESTAWU PERKUSYJNEGO | 9 |
| METRONOM | 9 |
| FUNKCJA PRAKTYCZNA | 9 |
| TRYB AUTOKARA | 9 |
| PIOSENKA DEMO | 10 |
| PARAMETRY BĘBNA | 10 |
| FUNKCJA NAGRYWANIA | 10 |
| ZAPISZ / RESETUJ | 10 |
| USBMIDI | 10 |
| ZAŁĄCZNIK | 11 |
| TAMBRA BĘBNA | 11 |
| PRESET ZESTAWÓW PERKUSYJNYCH | 11 |
| ZESTAWY PERKUSYJNE DEFINIOWANE PRZEZ UŻYTKOWNIKA | 11 |
| PIOSENKA DEMONSTRACYJNA | 11 |
| KONSERWACJA PRODUKTU | 12 |
| ŚRODKI OSTROŻNOŚCI | 13 |



INSTRUKCJA INSTALACJI

UWAGA!

- Postępuj zgodnie z instrukcjami i uważnie przeczytaj „Środki ostrożności” zawarte w Instrukcji obsługi przed użyciem .
- Ten produkt musi zainstalować osoba dorosła. Nie pozwól, aby osoba niepełnoletnia zainstalowała go samodzielnie.

01

Sprawdź załączone elementy

- Po otwarciu opakowania należy natychmiast sprawdzić, czy zawiera wszystkie elementy. Jeśli czegoś brakuje, skontaktuj się ze sprzedawcą.



Moduł dźwiękowy



Wspornik modułu



Talerz*3



Tomek (3 szt.)



Sidla



Pałka perkusyjna



Pedał*2



Kabel do podłączenia sygnału



Zasilacz

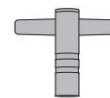

Klucz do bębna



Ramię do jazdy/zderzania



Ramię hi-hatu



INSTRUKCJA INSTALACJI

02

Stojak do montażu rur

• Stojak znajduje się w małym, indywidualnym opakowaniu wewnątrz pudełka.

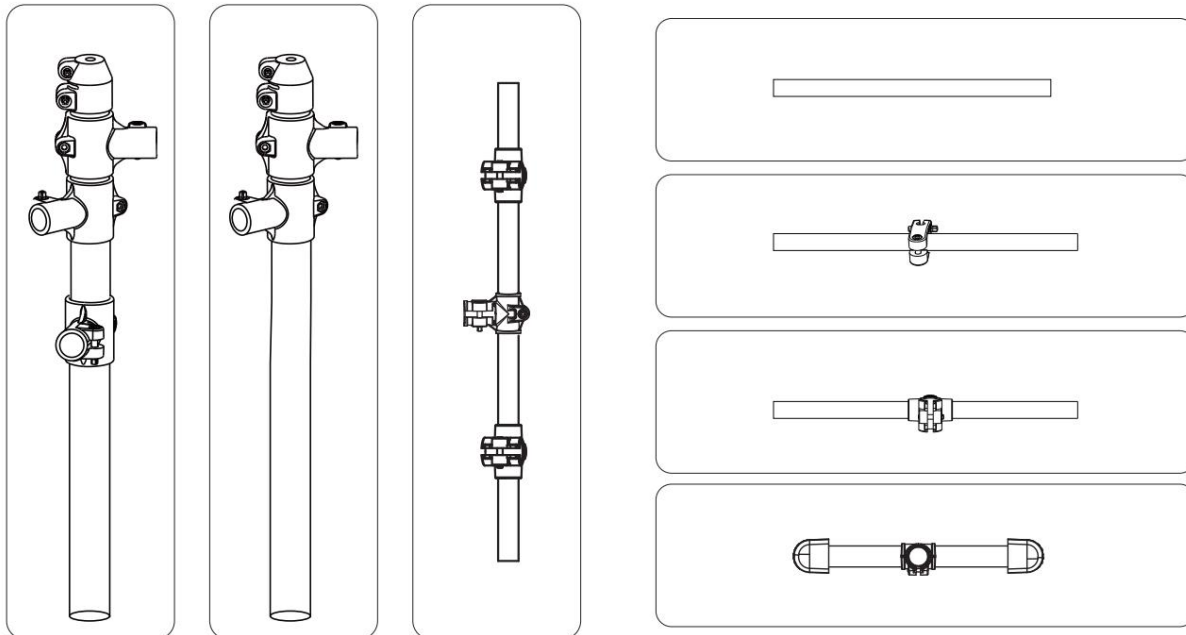

Stojak montażowy

03 • Stojak należy zamontować na miejscu i przykręcić śruby przy pomocy klucza do bębna.

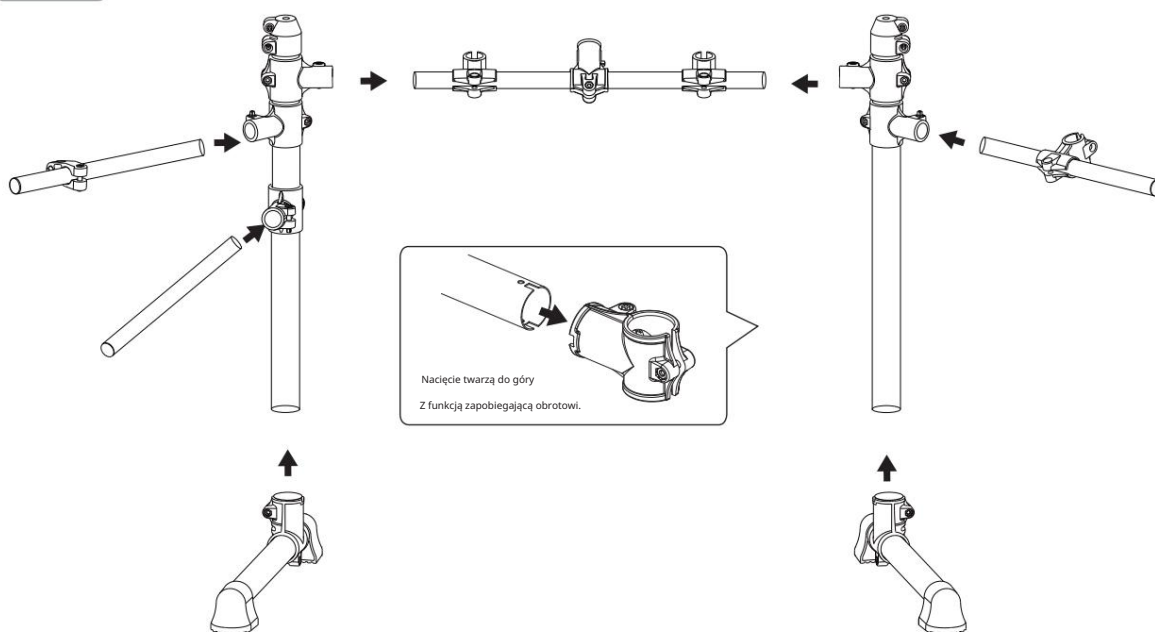



INSTRUKCJA INSTALACJI

04

Montaż miski bębna

• Proszę zachować ostrożność i nie przytrzasnąć sobie palców podczas instalacji.

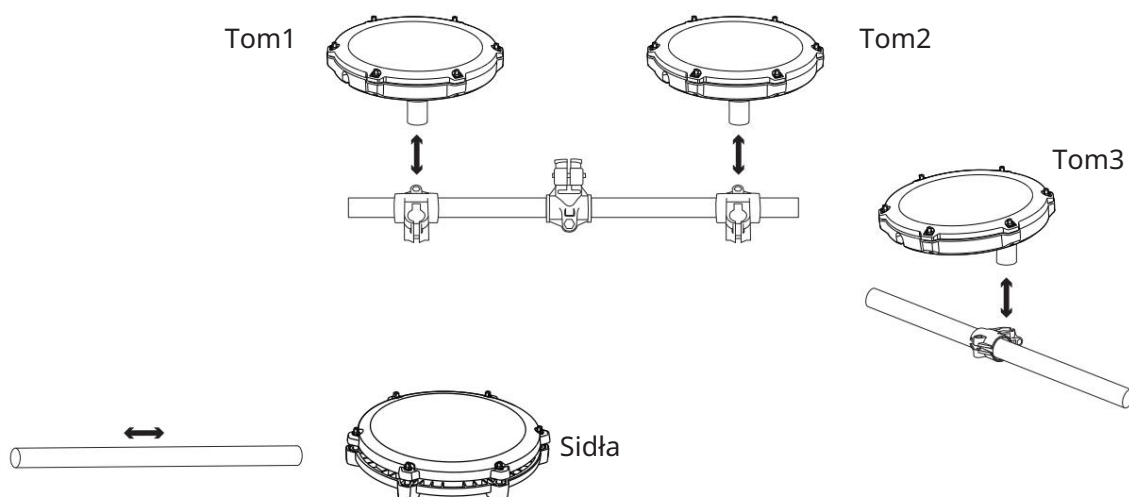

05

Instalacja modułu dźwiękowego • Zamontuj moduł dźwiękowy na stojaku przed przymocowaniem go do zestawu perkusyjnego.

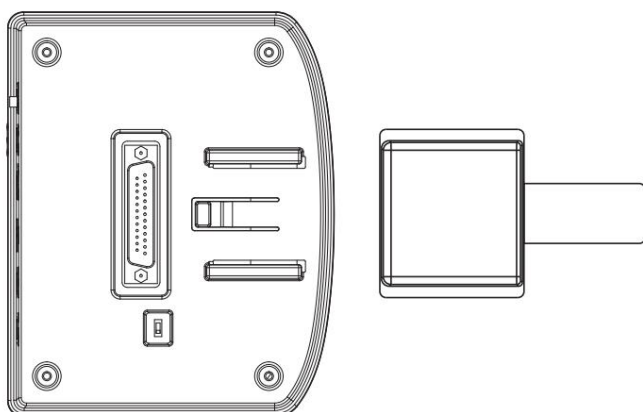

Włóż wspornik skrzynki głównej do ścieżki modułu dźwiękowego, a po włożeniu go na spód usłyszysz wyskakujące kliknięcie.



INSTRUKCJA INSTALACJI

06

Zainstaluj talerze, moduł dźwiękowy, umieść pedały

- Pamiętaj, aby nie dokręcać talerza zbyt mocno, zostaw trochę miejsca, aby talerz mógł poruszać się w górę i w dół.

Zainstaluj talerz i moduł dźwiękowy na stojaku, jak pokazano na rysunku

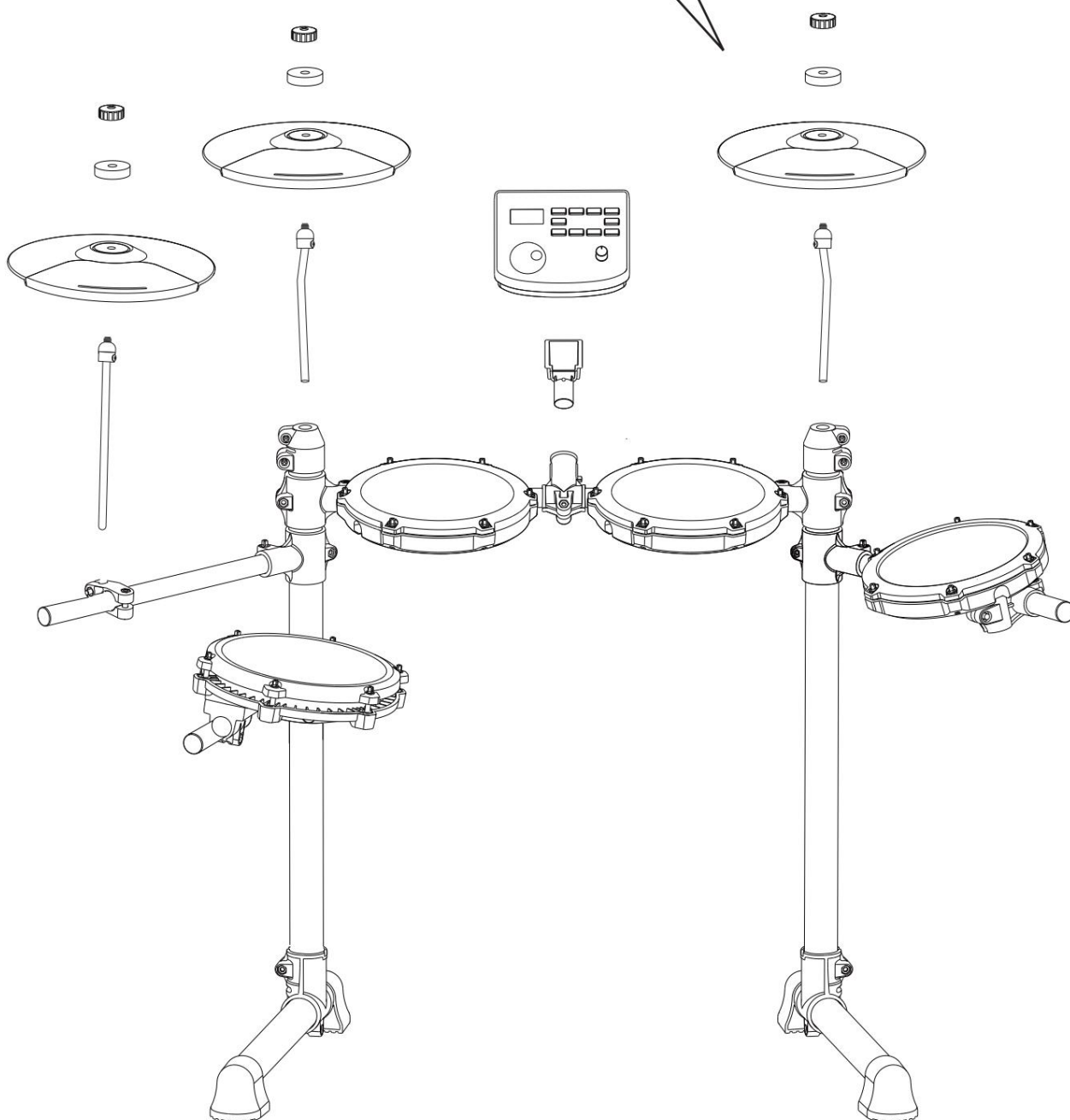



INSTRUKCJA INSTALACJI

07

Włóż kabel łączący część uderzającą

•Włóż kabel połączeniowy na miejsce, aby uniknąć słabego styku, i włóż go prawidłowo, jak pokazano na schemacie.

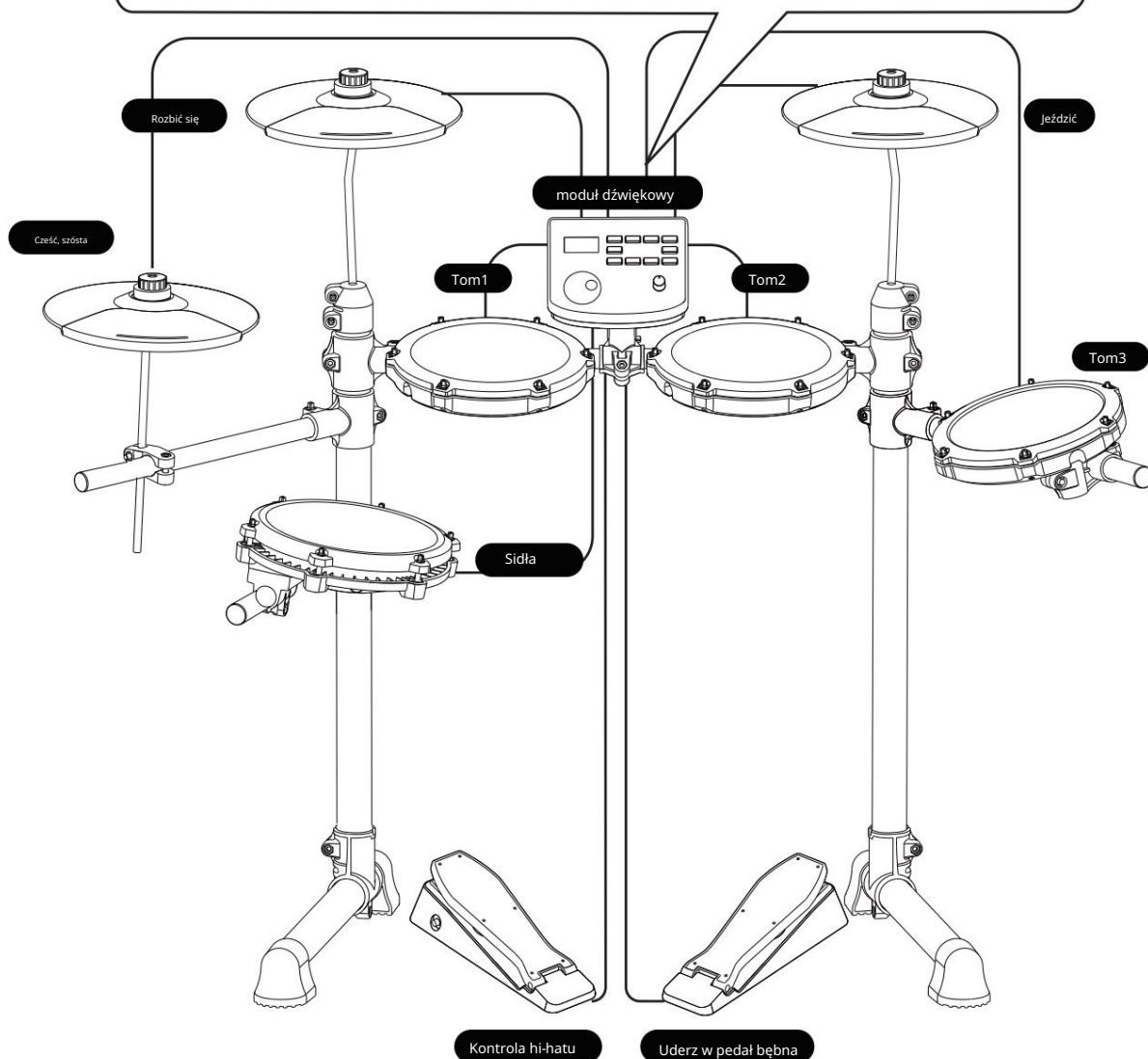
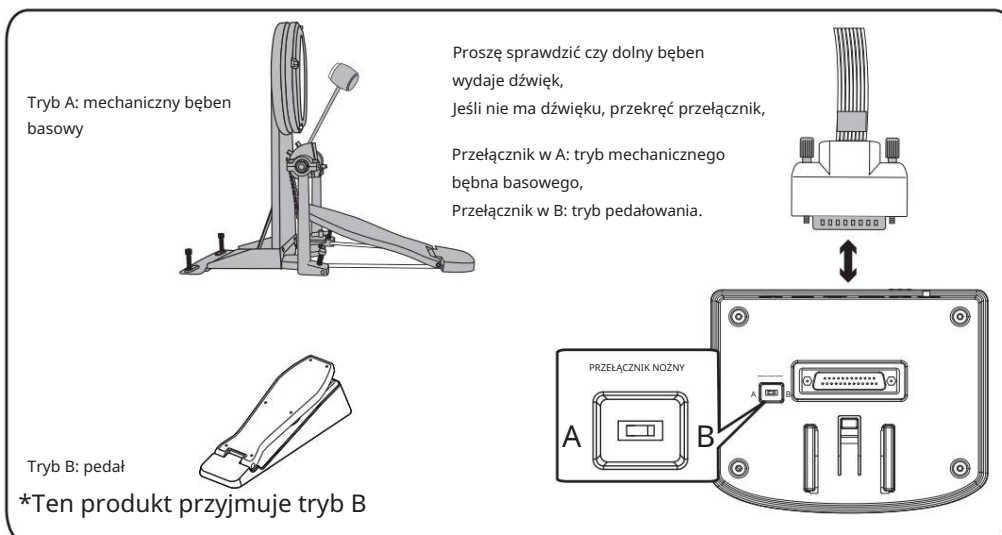



ILUSTRACJA PORTU MODUŁU DŹWIĘKOWEGO

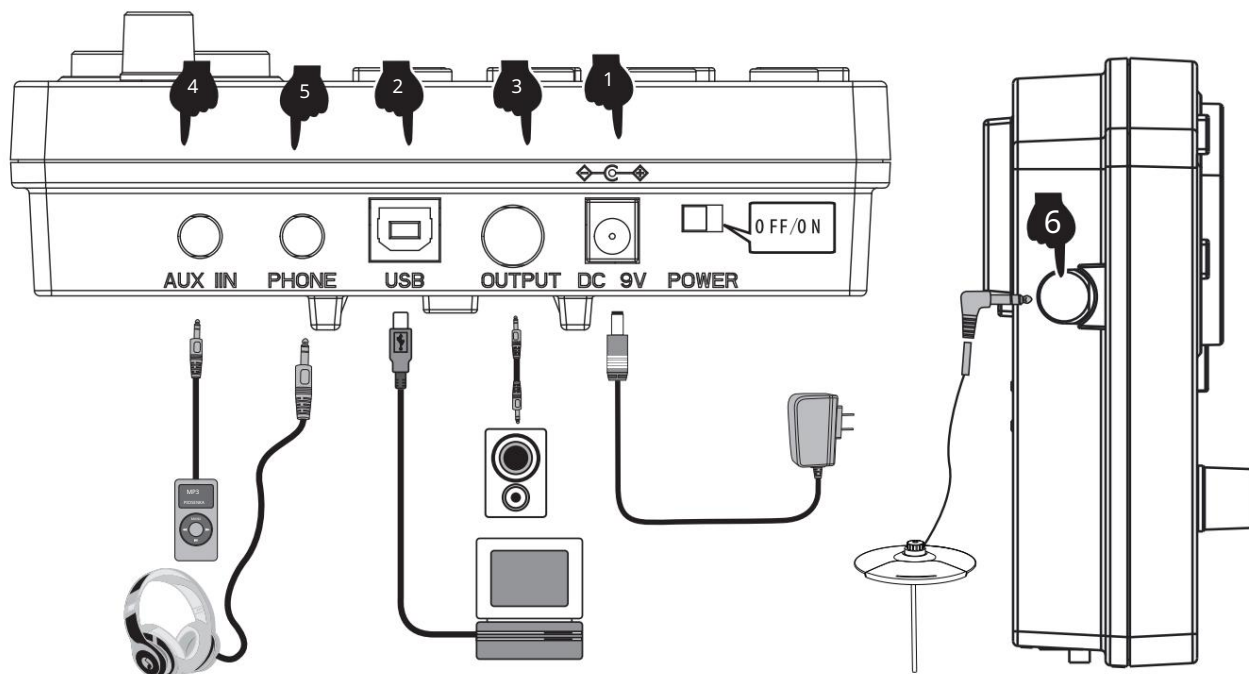

1 POŁĄCZENIE KABLA ZASILAJĄCEGO

1. W trakcie użytkowania podłączyć zacisk zasilania zgodnie ze schematem, włożyć gniazdo zasilania puszkę modułu o godz jednym końcu i gniazdka elektrycznym 100–240 V na drugim końcu. (ryc. 1)
2. Jeśli nie używasz tego produktu przez dłuższy czas, wyjmij wtyczkę z gniazdka i trzymaj ją prawidłowo.

2 PORT MIDI USB

Dzięki zastosowaniu perkusji elektronicznej interfejs MIDI USB umożliwia interakcję z urządzeniami muzycznymi wyposażonymi w interfejs MIDI.

1. Dzięki preinstalowanemu oprogramowaniu muzycznemu na komputerach i telefonach komórkowych możemy nauczyć się grać, komponować muzykę, sklep i inne funkcje. (ryc. 2)
2. Po podłączeniu do komputera lub telefonu komórkowego wyjście audio urządzenia musi być podłączone do audio gniazdo wejściowe modułu dźwiękowego w celu synchronizacji efektów dźwiękowych w urządzeniu. (ryc. 5)

3 PORT WYJŚCIA AUDIO

Port wyjściowy audio można podłączyć do aktywnego głośnika (specjalnego elektronicznego głośnika perkusyjnego) i dużego sprzętu audio. (ryc. 3)

4 PORT WEJŚCIA AUDIO

Port wejściowy audio może podłączyć urządzenie odtwarzające źródło dźwięku do modułu modułu w celu odtwarzania (np. MP3, telefon komórkowy i inne wejście sygnału audio). (ryc. 4)

5 PORT SŁUCHAWKOWY

Podłączenie słuchawek monitoruje szczegóły perkusji i nie przeszkadza innym podczas grania bez podłączenia głośników. (ryc. 5)

6 ZWIĘKSZ PORT

Ten port umożliwia dodanie talerza w celu łatwej rozbudowy. (Rysunek 6)



PRZEWODNIK PO OPERACJACH

1 MOC

Włóż wtyczkę DC do portu DC 9 V na górze modułu dźwiękowego. Przesuń przełącznik POWER w prawo (patrząc od przodu), aby włączyć zestaw perkusyjny. Aby wyłączyć zestaw perkusyjny, przesuń przełącznik w lewo.

WYBÓR 2 ZESTAWÓW PERKUSYJNYCH

Naciśnij przycisk KIT, aby wyświetlić bieżący zestaw perkusyjny. Obróć pokrętko parametrów lub użyj przycisków <- /+>, aby wybrać żądany zestaw perkusyjny. Do wyboru jest 15 zestawów perkusyjnych – patrz lista zestawów perkusyjnych na stronie 11.

3 METRONOM

- Naciśnij przycisk METRONOME, aby przejść do trybu metronomu.
- Na ekranie wyświetli się wartość prędkości (domyślna prędkość 120 BPM). Obróć pokrętko parametrów lub użyj przycisków +/- przyciski służące do zmiany szybkości metronomu. Naciśnij przycisk CLICK, aby uruchomić metronom.
- Naciśnij przycisk SELECT w trybie metronomu, a ekran przeskoczy do parametru metronomu interfejs regulacji. Za pomocą przycisków +/- możesz wybrać parametr, który chcesz wyregulować:
 - r (typ rytmu: 2,4,8,16)
 - b (numer rytmu: 01-09)
 - L(głośność metronomu: 00 (wyłączony) -31), a następnie obróć pokrętko parametrów, aby dostosować ustawienia parametrów.
- Po ustawieniu parametrów naciśnij przycisk SELECT, aby potwierdzić i wyjść z parametru interfejs. Następnie
- Użyj przycisku kliknięcia, aby uruchomić i zatrzymać metronom zgodnie z potrzebami.

4 FUNKCJA PRAKTYCZNA

Tryb trenera „trenera” tego produktu może pomóc w ustaleniu szybkości, dokładności i wytrzymałości, a także pomóc w kultywowaniu ćwiczyć funkcję lepszego poczucia rytmu. Rób postępy pod okiem trybu trenera „coach”!

Naciśnij przycisk „trener”, aby przejść do trybu trenera. W tym trybie dostępne są trzy tryby ćwiczeń. Wybierz praktykę tryb za pomocą koła danych lub przycisku < + > < - >.

- Tryb ćwiczeń 1: Ćwiczenie z wykrywaniem uderzeń C-1: uderzaj w bęben ze stałą prędkością, aby ćwiczyć dokładność uderzenia.
- Tryb ćwiczeń 2: Tryb cichego uderzenia C-2: metronom zabrzmi w jednej sekcji i wyciszy jedną sekcję, aby ćwiczyć dokładność uderzenia bez podpowiedzi metronomu. Jest to zaawansowana wersja trybu ćwiczeń 1.
- Tryb ćwiczeń 3: Ćwiczenie uderzeń z szybkością C-3, metronom automatycznie zmieni prędkość, zwiększy się od najwolniejszego ekspresu do najszybszego, a następnie zmniejsz prędkość z najwolniejszego ekspresu do najwolniejszej, aby ćwiczyć wytrzymałość na uderzenie.

5 TRYB TRENERA

- Tryb treningu „trenera” tego produktu może pomóc w ustaleniu szybkości, dokładności i wytrzymałości. Naciśnij COACH przycisk, aby przejść do trybu autokaru. W tym trybie dostępne są trzy tryby ćwiczeń. Do wyboru użyj koła parametrów jaki tryb ćwiczeń.
 - Tryb ćwiczeń 1: Ćwiczenie z wykrywaniem uderzeń C-1 – uderzaj w bęben ze stałą prędkością, aby ćwiczyć dokładność uderzenia.
 - Tryb ćwiczeń 2: Tryb cichego uderzenia C-2 – metronom włączy dźwięk w jednej sekcji i wyciszy jedną sekcję, aby ćwiczyć kiedy nie ma rytmu.
 - Tryb ćwiczeń 3: Ćwiczenie szybkości C-3 – metronom automatycznie zmieni prędkość od najwolniejszej do najszybszego, a następnie najszybszego do najwolniejszego.
- Po wybraniu trybu coachingu naciśnij przycisk KLIKNIJ. Rozpoczną się uderzenia metronomu i będziesz mógł grać na bębnie w ramach ćwiczeń.
3. Po czterech uderzeniach wstępnych na wyświetlaczu pojawi się:



PRZEWODNIK PO OPERACJACH

(za wolno)



(Dobry)



(za szybko)



4. Po zakończeniu trybu coachingu zostanie wyświetlona punktacja od 0 do 100, oceniająca dokładność ćwiczenie.

Tryb C-1: Naciśnij przycisk SELECT, aby wejść do interfejsu ustawień parametrów. Możesz dostosować liczbę ćwiczeń sesje według potrzeb (01-32). Liczba sesji do ćwiczenia określa długość tego ćwiczenia.

Tryb C-2: Naciśnij przycisk SELECT, aby wejść do interfejsu ustawień parametrów. Możesz dostosować liczbę ćwiczeń sesje w razie potrzeby (04-32). Liczba sesji do ćwiczenia określa długość tego ćwiczenia.

Tryb C-3: Naciśnij przycisk SELECT, aby wejść do interfejsu ustawień parametrów. Można dostosować tempo, w jakim BPM zmiany (01-09 BPM).

5. Naciśnij ponownie przycisk KLIKNIJ, aby zakończyć tryb autokaru.

6 utworów demonstracyjnych

1. Naciśnij przycisk SONG, aby przejść do trybu demonstracyjnego. Do wyboru jest 30 wersji demonstracyjnych. Na ekranie wyświetli się numer bieżącego utworu demonstracyjnego (01-30).
2. Naciśnij przycisk <▶> aby rozpocząć odtwarzanie utworów demonstracyjnych. Aby zatrzymać odtwarzanie, naciśnij ponownie przycisk <>.
3. Obróć pokrętko parametrów lub naciśnij przyciski +/-, aby wybrać utwór demonstracyjny.
4. Naciśnij przycisk SELECT w trybie utworu, aby przejść do interfejsu ustawień parametrów utworu. Możesz włączyć dźwięk perkusji włączać i wyłączać, obracając pokrętko parametrów (dźwięk perkusji jest domyślnie włączony).
5. Naciśnij przycisk SELECT, aby potwierdzić i wyjść z interfejsu parametrów.

7 PARAMETRY BĘBNA

1. Naciśnij przycisk KIT, a na ekranie wyświetli się 01 (numer zestawu perkusyjnego). Naciśnij SELECT, aby wprowadzić parametr bębna tryb regulacji.
 2. Stuknij bęben, który chcesz wyregulować, a następnie naciskaj przyciski +/-, aby wybrać parametr do regulacji. Czułość S (01-06). Próg wyzwolenia t (01 - 32). Próg przesłuchu c (01 - 32) Powtarzające się wyzwolenie r (01-32) Siła bębna V (01-03). Objętość bębna L (00 - 31).
 3. Zmień parametry, obracając pokrętko parametrów i naciśnij długo przycisk -, aby zapisać. Ekran z wyświetlaczem SAV, aby wskazać, że regulacja parametrów została pomyślnie zapisana.
 4. Aby przywrócić parametry bębna do ustawień fabrycznych, naciskaj i przytrzymaj przycisk +, aż na ekranie pojawi się komunikat PROSZĘ O RES
- UWAGA: Parametry dla bębnów 3-tomowych nie mogą być ustawiane indywidualnie.

8 FUNKCJA NAGRYWANIA

1. Naciśnij przycisk <REC>, gdy kontrolka znajduje się w stanie „KIT” i „CLICK”, a na ekranie pojawi się słowo „REC” w stanie migania oddechu, wejście w stan przygotowania do nagrywania.
2. Stuknij w dowolny bęben, a metronom zabrzmi. W tym momencie na ekranie pojawi się „---” w migającym stanie oddychania i rozpoczyna nagrywanie.
3. Naciśnij ponownie klawisz <REC> lub <PLAY>, nagrywanie zostanie zatrzymane, a na ekranie wyświetli się „A-1”.
4. Naciśnij <▶>, aby rozpocząć odtwarzanie bieżącego nagrania, i naciśnij ponownie, aby zatrzymać odtwarzanie.
5. Jeżeli bez pukania wejdziemy ponownie w stan przygotowania do nagrywania, odtworzone zostanie ostatnio nagrane „A-1”.

9 ZAPISZ/RESETUJ

1. Aby zapisać parametry naciśnij i przytrzymaj przycisk <->, na ekranie wyświetli się SAV.
2. Aby zresetować parametry naciśnij i przytrzymaj przycisk <+>, a na ekranie wyświetli się RES res.

10 USBMIDI

Aby korzystać z funkcji MID zestawu perkusyjnego, podłącz kabel danych USB-B (nie dołączony do tego zestawu perkusyjnego) do jednostki sterującej i podłącz do komputera/smartfona.



APPENDIX

Timbre

| | | | |
|------------------------------------|--------------------------------|----------------------------------|-----------------------------------|
| kopnięcie | 39 . Obręcz werbla jazzowego | 78 . Pop-rockowy Tom3 | 116 . Popularny Crash2 |
| 1 . Funkowe kopnięcie | 40 . Bluesowa obręcz werbla | 79 . Rock Tom3 | 117 . Awaria bezpiecznika 2 |
| 2 . Oryginalne kopnięcie | 41 . Popularny werbel | 80 . Zobacz Tom3 | 118 . Wypadek w Dancehallu 2 |
| 3 . Poprockowe uderzenie | 42 . Bezpiecznik Snare Rim | 81 . SpeedMetal Tom3 | 119 . Awaria Synthgaze2 |
| 4 . Rockowe kopnięcie | 43 . Dancehall Snare Rim | 82 . KlasycznyDry Tom3 | 120 . Standardowa awaria 2 |
| 5 . Sesionowe kopnięcie | 44 . Synthgaze Snare Rim | 83 . Nowoczesny Tom3 | Jeździć |
| 6 . SpeedMetalowe kopnięcie | 45 . Standardowa obręcz werbla | 84 . Jazz Tom3 | 121 . Funkowa jazda |
| 7 . Klasyczne kopnięcie na sucho | Tomek | 85 . Blues Tom3 | 122 . Oryginalna jazda |
| 8 . Nowoczesne kopnięcie | 46 . Funk Tom1 | 86 . Popularny Tom3 | 123 . Poprockowa przejażdżka |
| 9 . Jazzowy kop | 47 . Oryginalny Tom1 | 87 . Bezpiecznik Tom3 | 124 . Rockowa przejażdżka |
| 10 . Bluesowy kop | 48 . Pop-rockowy Tom1 | 88 . Dancehall Tom3 | 125 . Jazda sesyjna |
| 11 . Popularne kopnięcie | 49 . Rock Tom1 | 89 . Synthgaze Tom3 | 126 . Przejażdżka SpeedMetalem |
| 12 . Kopnięcie bezpiecznika | 50 . Sesja Tom1 | 90 . Standardowy Tom3 | 127 . Klasyczna jazda na sucho |
| 13 . Dancehallowe kopnięcie | 51 . SpeedMetal Tom1 | Rozbić się | 128 . Nowoczesna jazda |
| 14 . Synthgaze Kick | 52 . KlasycznyDry Tom1 | 91 . Funk Crash 1 | 129 . Jazda Jazzowa |
| 15 . Standardowe kopnięcie | 53 . Nowoczesny Tom1 | 92 . Oryginalna awaria 1 | 130 . Bluesowa przejażdżka |
| Sidla | 54 . Jazz Tom 1 | 93 . Pop-rockowy krach 1 | 131 . Popularna przejażdżka |
| 16 . Funkowy werbel | 55 . Blues Tom 1 | 94 . Uderzenie skały 1 | 132 . Jazda bezpiecznikiem |
| 17 . Oryginalny Snarek | 56 . Popularny Tom1 | 95 . Awaria Sesji 1 | 133 . Przejażdżka Dancehallem |
| 18 . Pop-rockowy werbel | 57 . Bezpiecznik Tom1 | 96 . Awaria SpeedMetal1 | 134 . Przejażdżka Synthgazem |
| 19 . Rockowy werbel | 58 . Dancehall Tom 1 | 97 . Klasyczna awaria na sucho 1 | 135 . Standardowa jazda |
| 20 . Seesion Snare | 59 . Synthgaze Tom1 | 98 . Współczesny wypadek 1 | HiHat |
| 21 . SpeedMetalowa pułapka | 60 . Standardowy Tom1 | 99 . Jazzowy krach 1 | 136 . Funk Hi-Hat otwarty |
| 22 . Klasyczny suchy werbel | 61 . Funk Tom2 | 100 . Bluesowy krach 1 | 137 . Oryginalny Hi-Hat otwarty |
| 23 . Nowoczesny werbel | 62 . Oryginalny Tom2 | 101 . Popularny Crash1 | 138 . Pop-rockowy hi-hat otwarty |
| 24 . Werbel jazzowy | 63 . Pop-rockowy Tom2 | 102 . Awaria bezpiecznika 1 | 139 . Rockowy hi-hat otwarty |
| 25 . Bluesowa pułapka | 64 . Rock Tom2 | 103 . Wypadek w Dancehallu 1 | 140 . Seesion Hi-Hat otwarty |
| 26 . Popularny werbel | 65 . Zobacz Tom2 | 104 . Awaria Synthgaze1 | 141 . Otwarty hi-hat SpeedMetal |
| 27 . Bezpiecznik Snare | 66 . SpeedMetal Tom2 | 105 . Standardowa awaria 1 | 142 . Hi-Hat ClassicDry otwarty |
| 28 . Dancehallowe werble | 67 . KlasycznyDry Tom2 | 106 . Funk Crash2 | 143 . Nowoczesny Hi-Hat otwarty |
| 29 . Synthgaze Snare | 68 . Nowoczesny Tom2 | 107 . Oryginalny Crash2 | 144 . Jazzowy Hi-Hat Otwarty |
| 30 . Standardowy werbel | 69 . Jazz Tom2 | 108 . Poprockowy wypadek 2 | 145 . Otwarty hi-hat bluesowy |
| 31 . Funk Snare Rim | 70 . Blues Tom2 | 109 . Uderzenie skały 2 | 146 . Popularny Hi-Hat otwarty |
| 32 . Oryginalna obręcz werbla | 71 . Popularny Tom2 | 110 . Awaria Sesji 2 | 147 . Bezpiecznik Hi-Hat otwarty |
| 33 . Pop-rockowy rym werblowy | 72 . Bezpiecznik Tom2 | 111 . Awaria SpeedMetal2 | 148 . Otwarty Hi-Hat Dancehall |
| 34 . Rockowa obręcz werbla | 73 . Dancehall Tom2 | 112 . Klasyczna awaria na sucho2 | 149 . Synthgaze Hi-Hat otwarty |
| 35 . Seesion Snare Rim | 74 . Synthgaze Tom2 | 113 . Nowoczesny Crash2 | 150 . Standardowy Hi-Hat otwarty |
| 36 . Obręcz werbla SpeedMetal | 75 . Standardowy Tom2 | 114 . Jazzowy krach 2 | 151 . Funkowy hi-hat blisko |
| 37 . Klasyczna sucha obręcz werbla | 76 . Funk Tom3 | 115 . Bluesowy krach 2 | 152 . Oryginalny hi-hat zamknięty |
| 38 . Nowoczesna obręcz werbla | 77 . Oryginalny Tom3 | | |



APPENDIX

| | | |
|--|------------------------------------|----------------------------------|
| 153 . Poprockowy hi-hat blisko | 163 . Hi-Hat Dancehall blisko | 173 . Nowoczesny pedał hi-hat |
| 154 . Rockowy hi-hat blisko | 164 . Synthgaze Hi-Hat Zamknij | 174 . Pedał jazzowego hi-hatu |
| 155 . Seesion Hi-Hat blisko | 165 . Standardowy hi-hat zamknięty | 175 . Pedał bluesowego hi-hatu |
| 156 . Zamknięcie hi-hatu SpeedMetal | 166 . Funkowy pedał hi-hat | 176 . Popularny pedał Hi-Hat |
| 157 . Klasyczny suchy hi-hat zamknięty | 167 . Oryginalny pedał hi-hat | 177 . Pedał Fuse Hi-Hat |
| 158 . Nowoczesny hi-hat zamknięty | 168 . Pop-rockowy pedał hi-hatu | 178 . Pedał do hi-hatu Dancehall |
| 159 . Jazzowy hi-hat blisko | 169 . Pedał rockowego hi-hatu | 179 . Pedał Hi-Hat Synthgaze |
| 160 . Bluesowy hi-hat blisko | 170 . Pedał Hi-Hat firmy Seesion | 180 . Standardowy pedał hi-hatu |
| 161 . Popularny Hi-Hat Close | 171 . Pedał SpeedMetal Hi-Hat | |
| 162 . Bezpiecznik Hi-Hat zamknięty | 172 . Pedał Hi-Hat ClassicDry | |

Drum combination timbre

Zestaw perkusyjny użytkownika

| | | | | |
|-------------|---------------|---------------|------------|--------------|
| 01 Funk | 04 Rock | 07 ClassicDry | 10 Blues | 13 Dancehall |
| 02 Original | 05 Seesion | 08 Modern | 11 Popular | 14 Synthgaze |
| 03 Poprock | 06 SpeedMetal | 09 Jazz | 12 Fuse | 15 Standard |

Piosenka demonstracyjna

| | | | | | | | |
|--------------|--------------|--------------|--------------|--------------|--------------|--------------|--------------|
| Piosenka 001 | Piosenka 005 | Piosenka 009 | Piosenka 013 | Piosenka 017 | Piosenka 021 | Piosenka 025 | Piosenka 029 |
| Piosenka 002 | Piosenka 006 | Piosenka 010 | Piosenka 014 | Piosenka 018 | Piosenka 022 | Piosenka 026 | Piosenka 030 |
| Piosenka 003 | Piosenka 007 | Piosenka 011 | Piosenka 015 | Piosenka 019 | Piosenka 023 | Piosenka 027 | |
| Piosenka 004 | Piosenka 008 | Piosenka 012 | Piosenka 016 | Piosenka 020 | Piosenka 024 | Piosenka 028 | |



PRODUCT MAINTENANCE

Careful maintenance and protection of the product, to extend the service life of the product, reduce the fault has a very important role.

1 AVOID HEATING, DAMPNES OR DIRECT SUNLIGHT

Do not over expose the product to direct sunlight, or place it near air conditioning or extremely hot place.

2 DO NOT USE NEAR THE TV OR RADIO

This product may cause video or audio interference to the reception of TV and radio. If this happens, the product should be removed from the TV or radio.

3 NO DILUENTS OR SIMILAR CHEMICALS SHOULD BE USED FOR CLEANING

Clean the product with a soft cloth wetted with weak water solution and neutral detergent. Soak the cloth in a solution and wring it dry until it approaches drying.

4 DO NOT SHAKE, AVOID COLLISION

When moving, the product should be handled carefully and lightly. Violent vibration and collision are strictly prohibited in order to avoid damage to the shell or internal electronic components.



SAFETY PRECAUTIONS

POWER SUPPLY

This product can be powered by standard indoor wall sockets. Please only use the power cord specified in this product. When not in use, please turn off the power supply. When not in use for a long time, pull out the power cord and keep it properly.

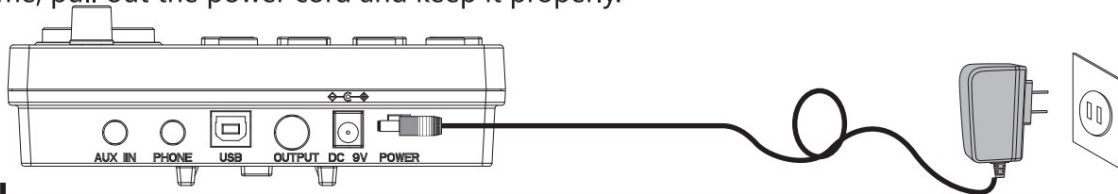

SIGN

To ensure that you use this product safely and correctly, to prevent harm to users and others and financial damage, this manual and products are marked with a series of safety signs. The various signs and their meanings are as follows:

WARNING

This sign indicates that there is a potential risk of death or serious injury if this mark is ignored and the product is mishandled.

BE CAREFUL

This sign indicates that there is a potential danger of injury to personnel or other financial damage if this sign is ignored and the product is operated incorrectly.

EXAMPLE OF LOGO



This triangle sign (Δ) indicates what users should pay attention to. (The left example is careful shocks)



A circular sign (\ominus) with an oblique line indicates prohibitions. The icons in or beside the logo indicate the contents specifically prohibited. (The example on the left is no disassembly)



The round black bottom sign (\odot) indicates what must be observed. The diagrams in this sign indicate the contents of the specific matters that must be observed. (The example on the left is that the power plug must be pulled out of the socket)



SAFETY PRECAUTIONS

WARNING

Smoke, odor, overheating

When the product smokes, smells or overheats, there is a danger of fire and electric shock when it is used continually. In case of the above situation, the following operations should be performed immediately:

1. Turn off the power supply.
2. Pull the plug out of the power outlet.
3. Contact your dealer.

Power cord

1. The improper use of power cord may cause fire and electric shock. The following precautions must be observed:

- The special power cord designated for this product must be used.
- The AC power supply with output voltage within the rated voltage range for household use must be used.
- Do not overload power sockets and extension lines.



2. The improper treatment of power line will lead to its damage or breakage, which will cause fire and electric shock hazards. The following precautions must be observed:

- Do not place or heat heavy objects on power lines.
- Do not attempt to alter or bend the power cord too much.
- Do not twist or pull the power cord.
- If the power cord or plug is damaged, please replace the same type of power cord.



3. Do not touch the power cord and plug with wet hands, otherwise there is a danger of electric shock.



4. Please use the power cord where the water will not splash. Water is in danger of causing fire and electric shock.



5. Never place vases or any other container containing water on this product. Water is dangerous of causing fire and electric shock.



6. Do not allow minors to unplug and touch power lines or connection boards. Minors have no common sense of electricity safety, which may cause electric shock.



BE CAREFUL

The improper use of power cord may cause fire and electric shock. The following precautions must be observed:

- Never put the power cord near the oven or other heat source.
- Do not pull the cable when pulling out of the power socket. The main body of the plug must be grasped.
- The power cord plug must be inserted in the socket to the end.
- Make sure the power supply is off before connecting or disconnecting it.
- When thunderstorms occur or before traveling or other long-term departure, disconnect the power cord from the wall outlet.
- At least once a year, remove the power cord from the wall outlet and clean the dust accumulated around the plug.



Do not burn this product

Do not put this product in the fire, otherwise it will lead to product combustion and explosion of internal electronic components, which will cause fire and personnel injury.



Water and foreign bodies

Water, other liquids and (metal sheets, etc.) entering this product are in danger of causing fire and electric shock. In case of the above situation, the following operations shall be performed immediately:



1. Turn off the power supply.
2. If you are using a power cord for power supply, unplug it from the wall outlet.
3. Contact your distributor.

Disassembly and transformation

Do not disassemble or transform the product in any way, otherwise there is a risk of electric shock, scald or other personal injury. All internal inspection, adjustment and maintenance operations should be entrusted to your distributor.





SAFETY PRECAUTIONS

Falling or colliding

If the product falls or is damaged by strong impact, it will be in danger of causing fire and electric shock. In case of the above situation, the following operations shall be performed immediately:

1. Turn off the power supply.
2. If you are using a power cord for power supply, you need to unplug it from the wall outlet.
3. Contact your distributor.



Plastic bag

Do not let anyone put plastic bags for this product on his head or in his mouth. Otherwise, there is a risk of asphyxia. Families with young children should pay special attention to it.



Keep a distance from the product and the bracket

Climbing the bracket is dangerous of overturning or damage. Families with young children should pay special attention to it.



Put

Avoid placing the product on an uneven surface or any other unstable place. Otherwise, it will cause the product to fall down, which will lead to the risk of injury.



Product Mobility

Before moving this product, you must unplug the power cord plug from the wall outlet and pull out all other cables and connecting wires. Otherwise, it will lead to damage of power or connection wires, resulting in fire and electric shock.



clean

Before cleaning this product, you must unplug the power cord plug from the wall outlet, otherwise there is a risk of fire and electric shock.



Jack

The socket of this product can only be connected to the designated equipment and devices. Connecting non-designated equipment or devices is dangerous of causing fire and electric shock.



Location selection

It should be avoided to place the product in the following places, otherwise there is a risk of fire and electric shock.

- High temperature or dusty places.
- Kitchen or other places with lampblack.
- Where the product is exposed to direct sunlight, or any other place where the product will produce high temperature.



Volume

Don't play music long and loud. Pay special attention when using headphones. Excessive volume can damage your hearing.



Heavy



Do not place heavy objects on this product. Otherwise, the top of the product will be overweight, causing the product to overturn or drop objects on it, which will lead to the risk of injury.



Correct assembly of scaffolds

The incorrect assembly of the bracket may overturn, causing the product to fall off and posing a risk of injury to personnel. Therefore, it must be assembled according to the instructions in the attached installation guide to ensure that the product is properly mounted on its bracket.



| | |
|--|--|
|  | <p>Ostrzeżenie — aby zmniejszyć ryzyko obrażeń, użytkownik musi uważnie przeczytać instrukcję obsługi.</p> |
|  | <p>To urządzenie jest zgodne z częścią 15 przepisów FCC. Działanie podlega następującym dwóm warunkom: (1) to urządzenie nie może powodować szkodliwych zakłóceń oraz (2) to urządzenie musi akceptować wszelkie odbierane zakłócenia, w tym zakłócenia, które mogą powodować niepożądane działanie.</p> |
|  | <p>Ten produkt podlega przepisom Dyrektywy Europejskiej 2012/19/WE. Symbol przekreślonego kosza na śmieci oznacza, że produkt wymaga selektywnej zbiórki śmieci na terenie Unii Europejskiej. Dotyczy to produktu i wszystkich akcesoriów oznaczonych tym symbolem. Produktów oznaczonych jako takie nie można wyrzucać razem ze zwykłymi odpadami domowymi, lecz należy je oddać do punktu zbiórki w celu recyklingu urządzeń elektrycznych i elektronicznych</p> |

Producent: Shanghaimuxinmuyeyouxiangongsi Adres:

Shuangchenglu 803nong11hao1602A-1609shi, baoshanqu, szanghaj
200000 CN.

Import do AUS: SIHAO PTY LTD, 1 ROKEVA STREETEASTWOOD NSW
2122 Australii

Import do USA: Sanven Technology Ltd., Suite 250, 9166 Anaheim Place, Rancho
Cucamonga, CA 91730

| | |
|--------------|--|
| REPREZENT KE | |
|--------------|--|

E-CrossStu GmbH

Mainzer Landstr.69, 60329 Frankfurt nad Menem.

| | |
|-----------------------------|--|
| REPUBLIKA Wielkiej Brytanii | |
|-----------------------------|--|

YH CONSULTING SPÓŁKA Z OGRANICZONĄ ODPOWIEDZIALNOŚCIĄ.

C/O YH Consulting Limited Office 147, Centurion House,
London Road, Staines-upon-Thames, Surrey, TW18 4AX

VEVOR[®]

TOUGH TOOLS, HALF PRICE

Wsparcie techniczne i certyfikat e-gwarancji

www.vevor.com/support

VEVOR[®]

TOUGH TOOLS, HALF PRICE

Technische ondersteuning en e-garantiecertificaat

www.vevor.com/support

ELEKTRONISCH DRUMSET HANDLEIDING

MODEL: MD200C

Wij blijven ons inzetten om u gereedschap te bieden tegen een concurrerende prijs.

"Bespaar de helft", "Halve prijs" of andere soortgelijke uitdrukkingen die door ons worden gebruikt vertegenwoordigt slechts een schatting van de besparingen die u zou kunnen profiteren door bepaalde gereedschappen bij ons te kopen in vergelijking met de grote topmerken en betekent niet noodzakelijkerwijs dat deze alle categorieën gereedschappen dekken door ons aangeboden. U wordt er vriendelijk aan herinnerd om, wanneer u een bestelling bij ons plaatst, zorgvuldig te verifiëren of u daadwerkelijk de helft bespaart in vergelijking met de grote topmerken.

VEVOR[®]

TOUGH TOOLS, HALF PRICE

ELEKTRONISCH DRUMSET

MODEL: MD200C

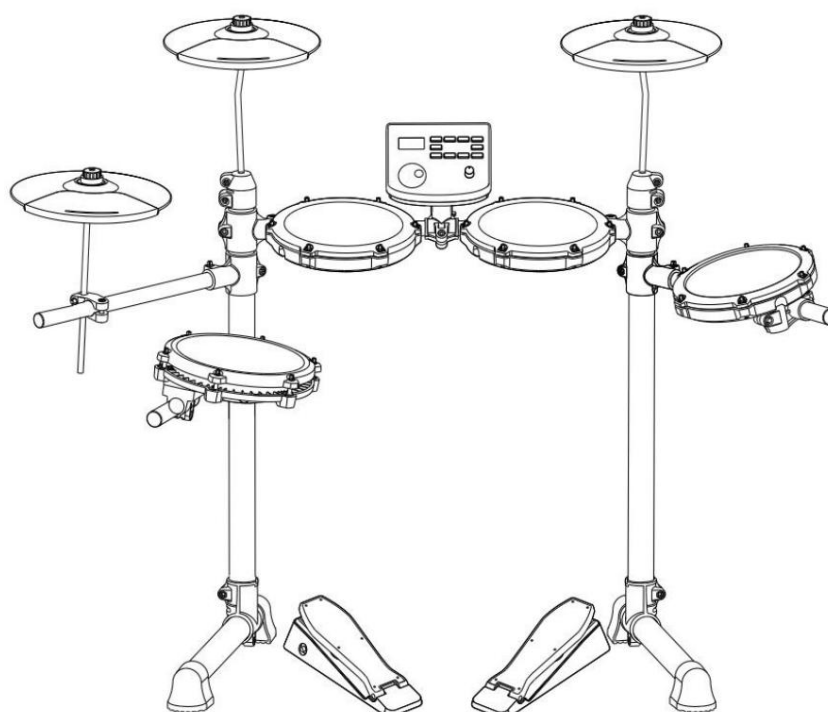

(De afbeelding is alleen ter referentie, raadpleeg het werkelijke object)

HULP NODIG? NEEM CONTACT MET ONS OP!

Heeft u productvragen? Technische ondersteuning nodig? Voel je vrij om neem contact

met ons op: **Technische ondersteuning en e-garantiecertificaat**
www.vevor.com/support

Dit is de originele instructie. Lees alle instructies in de handleiding zorgvuldig door voordat u ermee aan de slag gaat. VEVOR behoudt zich een duidelijke interpretatie van onze gebruikershandleiding voor. Het uiterlijk van het product is afhankelijk van het product dat u heeft ontvangen. Vergeef ons alstublieft dat we u niet opnieuw informeren als er technologie- of software-updates zijn voor ons product.



FUNCTIE INLEIDING

Bedankt dat u voor onze elektronische drum hebt gekozen. Elegante en delicate elektronische drum is de perfecte combinatie van moderne nieuwe elektronische technologie. •Voordat u dit product gebruikt, moet u de instructies in detail lezen.

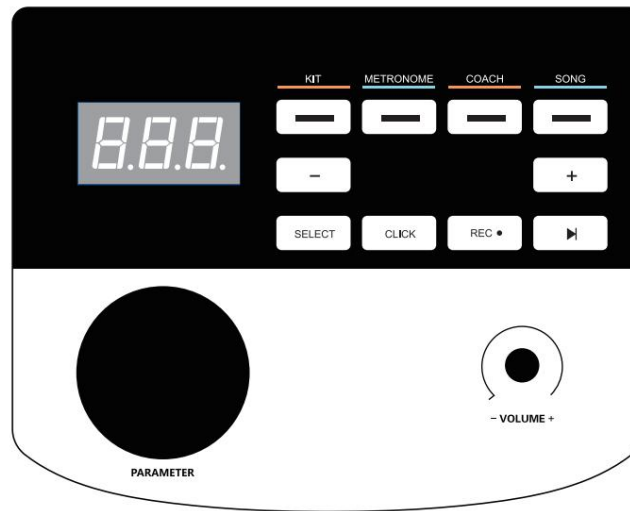

- 15 drumkits, 180 timbres

- 30

nummers • ondersteunen de aanpassing van de gevoeligheidsparameters van elke drum • drie

leermodi • snelheidsregeling: 30 ~ 250 slagen / min

- metronoom: 1-9 typen •

andere functies: parameteropslag, reset en opname; • driecijferig

LED-display; • interface:

voeding DC, usbmidi, oortelefoon, audio-ingang, audio-uitgang verhogen cimbaal

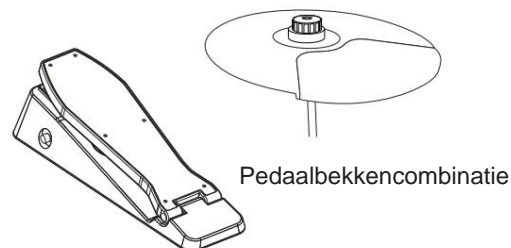

OPMERKING!

- Dit product is een elektro-akoestisch instrumentproduct. Het is normaal dat er een beetje stroming staat geluid uit de luidspreker of oortelefoon na het inschakelen.

Houd tijdens gebruik de buurt van "radio, TV, antenne-ontvanger, router, koelkast, TV, motor en andere RF-elektrische interferentiebronnen".



INHOUD

| | |
|---|-----------|
| FUNCTIE INLEIDING | 1 |
| INHOUD | 2 |
| INSTALLATIE GIDS | 3 |
| CONTROLEER DE BIJGEVOEGDE ITEMS | 3 |
| STANDPIJPFITTING | 4 |
| MONTAGESTANDAARD | 4 |
| INSTALLATIE VAN DE DRUMPAN | 5 |
| INSTALLATIE VAN GELUIDSMODULE | 5 |
| CYMBALEN INSTALLEREN, GELUIDSMODULE, PEDALEN PLAATSEN | 6 |
| PLAATS DE VERBINDINGSKABEL VAN HET SLAGONDERDEEL | 7 |
| ILLUSTRATIE VAN GELUIDSMODULEPOORT | 8 |
| AANSLUITING VAN HET STROOMKABEL | 8 |
| USB MIDI-POORT | 8 |
| AUDIO-UITVOERPOORT | 8 |
| AUDIO-INVUERPOORT | 8 |
| OORTELEFOONPOORT | 8 |
| BEDIENINGSHANDLEIDING | 9 |
| STROOM | 9 |
| DRUMKIT SELECTIE | 9 |
| METRONOOM | 9 |
| PRAKTIJKFUNCTIE | 9 |
| COACHMODUS | 9 |
| DEMO-SONG | 10 |
| TROMMELPARAMETERS | 10 |
| OPNAMEFUNCTIE | 10 |
| OPSLAAN / RESETTEN | 10 |
| USBMIDI | 10 |
| BIJLAGE | 11 |
| TROMMEL TIMBRE | 11 |
| VOORAF INGESTELDE DRUMKITS | 11 |
| DOOR GEBRUIKER GEDEFINIEERDE DRUMKITS | 11 |
| DEMONSTRATIELIED | 11 |
| PRODUCTONDERHOUD | 12 |
| VEILIGHEIDSMATREGELEN | 13 |



INSTALLATIE GIDS

OPMERKING!

- Volg de instructies en lees de "veiligheidsmaatregelen" in de gebruikershandleiding aandachtig voor gebruik .
- Dit product moet door een volwassene worden geïnstalleerd. Laat de minderjarige het niet zelfstandig installeren.

01

Controleer de bijgevoegde items

- Controleer na het openen van de verpakking onmiddellijk of alle artikelen erin zitten. Als er iets ontbreekt, neem dan contact op met uw dealer.



Geluidsmodule



Modulebeugel



Cimbaal*3



Tom (3 stuks)



Strik



Drumstok



Pedaal*2



Signaalaansluitkabel



Oplader

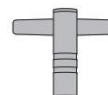

Drum sleutel



Rijd/crash-arm



Hi-hat-arm



INSTALLATIE GIDS

02

Montage van staande pijp

• De standaard bevindt zich in een klein individueel pakketje in de doos.

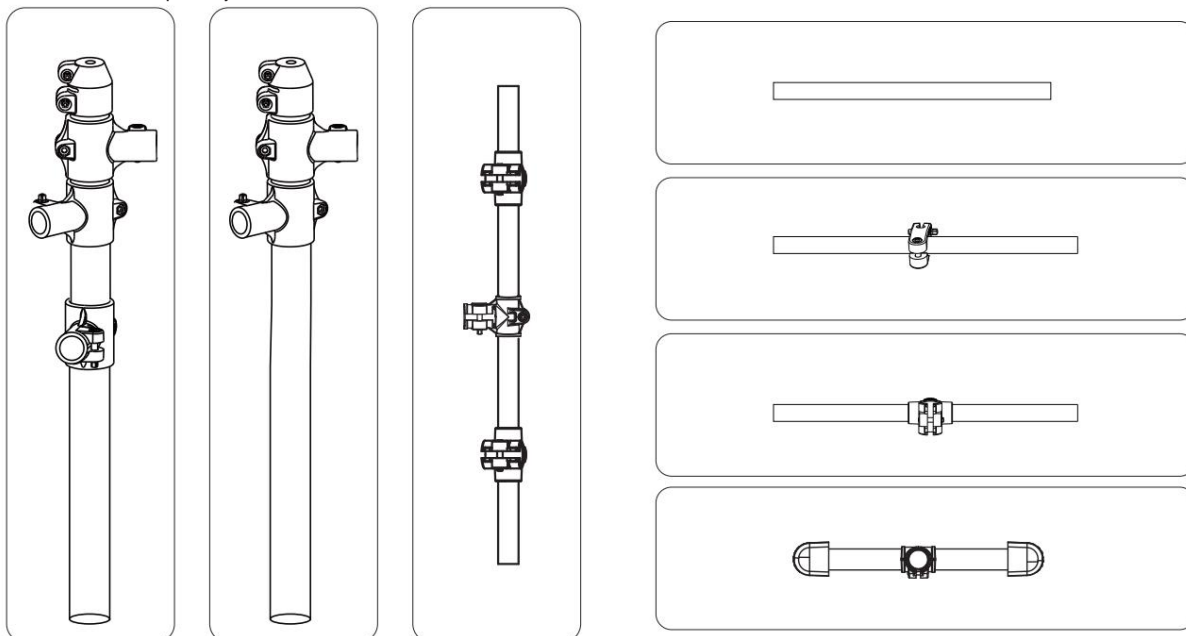

Montagestandaard

03 • De standaard moet op zijn plaats worden geïnstalleerd en de schroeven met de drumsleutel worden vastgedraaid.

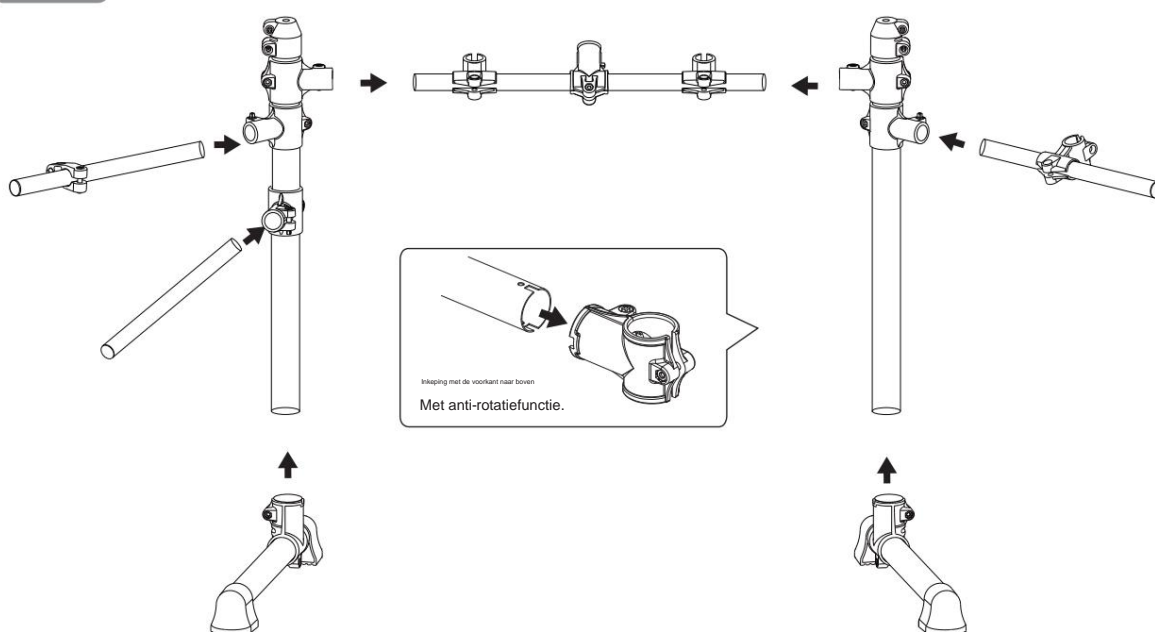



INSTALLATIE GIDS

04

Drumpan installatie

•Wees voorzichtig en zorg ervoor dat uw vingers niet bekneld raken tijdens de installatie.

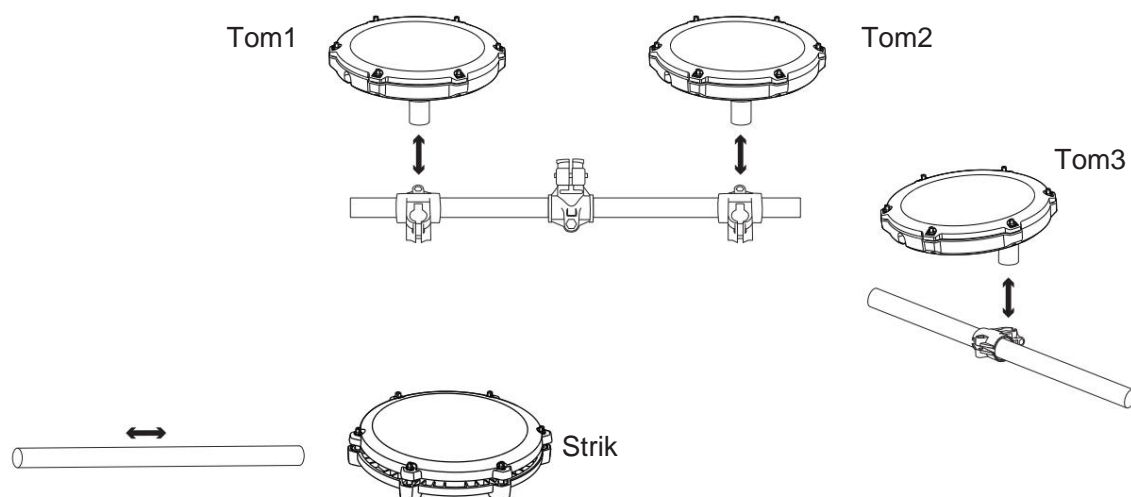

05

Installatie van de geluidsmodule •

Monteer de geluidsmodule met de standaard voordat u deze op het drumstel bevestigt.

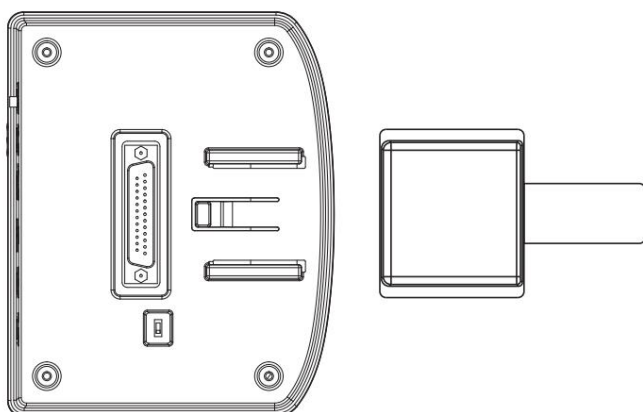

Plaats de beugel van de hoofdbox tegen het spoor van de geluidsmodule en u hoort het klikstuk omhoog komen wanneer u het op de bodem plaatst.



INSTALLATIE GIDS

06

Bekkens plaatsen, geluidsmodule, pedalen plaatsen

- Zorg ervoor dat u het bekken niet te strak vastdraait, maar zorg ervoor dat er wat ruimte overblijft zodat ze op en neer kunnen slingeren.

Installeer het bekken en de geluidsmodule op de standaard zoals weergegeven in de afbeelding

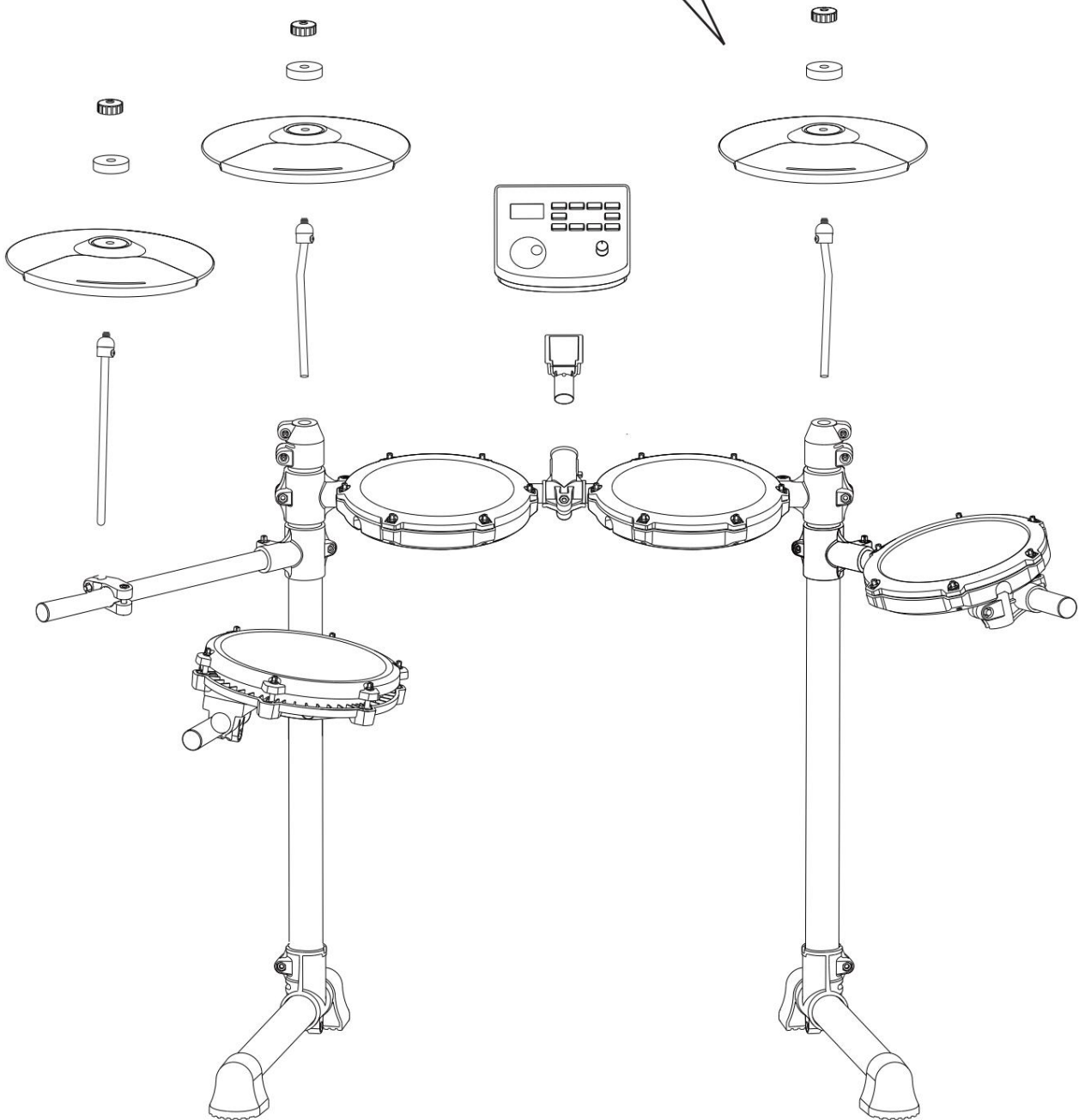
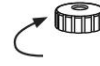



INSTALLATIE GIDS

07

Steek de verbindingkabel van het rakende deel erin

•Steek de verbindingkabel op zijn plaats om slecht contact te voorkomen en sluit deze op de juiste manier aan, zoals weergegeven in het diagram.

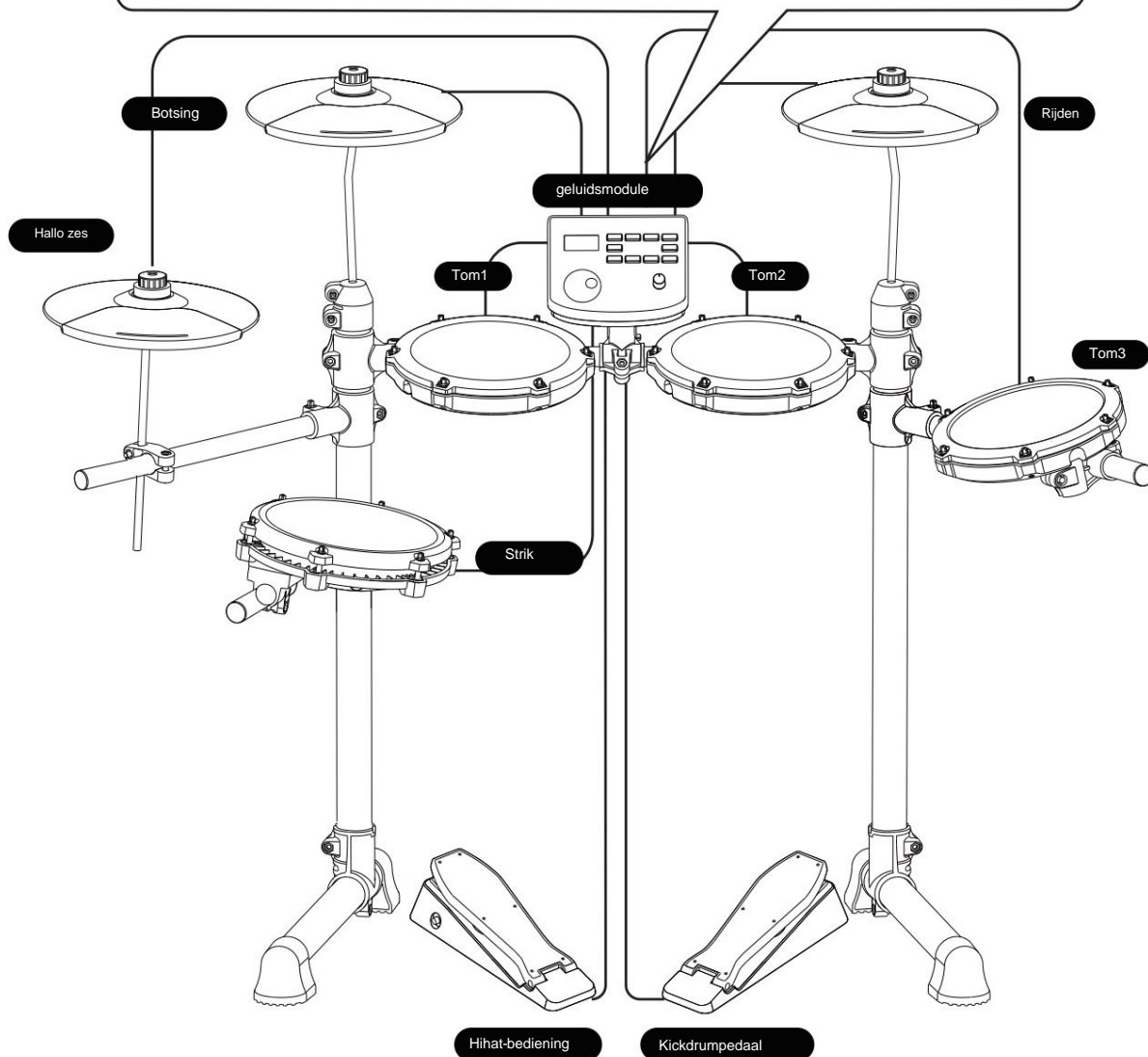
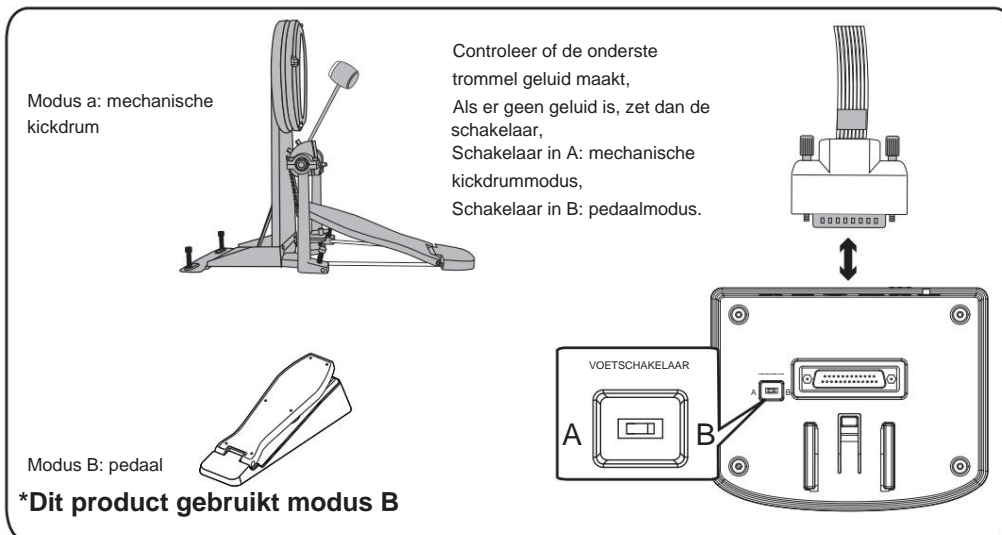



ILLUSTRATIE VAN GELUIDSMODULEPOORT

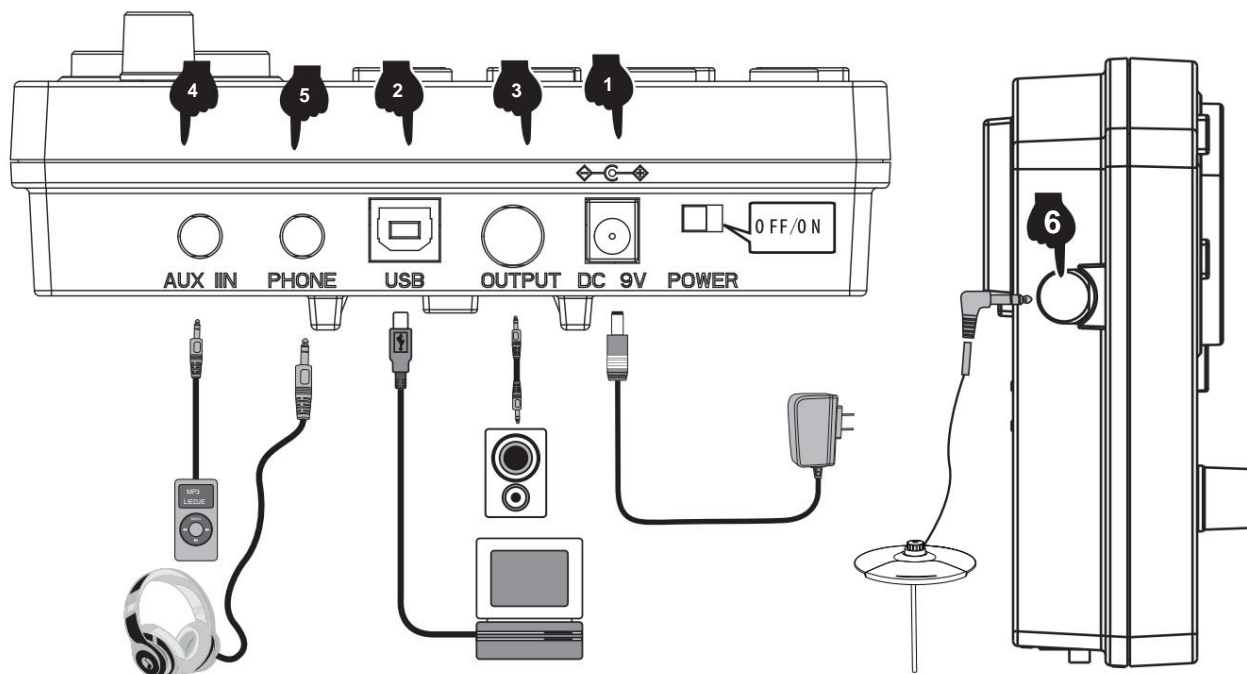

1 STROOMKABELAANSLUITING

1. Sluit tijdens gebruik de voedingsterminal aan volgens het diagram en steek het stopcontact van de modulekast in het ene uiteinde en een stopcontact van 100-240 V aan het andere uiteinde. (Figuur 1)
2. Als u dit product langere tijd niet gebruikt, trek dan de stekker uit het stopcontact en bewaar deze op de juiste manier.

2 USB MIDI-POORT

Het gebruik van een elektronische drum MIDI USB-interface kan communiceren met muziekapparaten met MIDI.

1. Via de vooraf geïnstalleerde muzieksoftware op computers en mobiele telefoons kunnen we leren spelen, muziek componeren, winkel en andere functies. (Fig. 2)
2. Bij aansluiting op een computer of mobiele telefoon moet de audio-uitgang van het apparaat op de audio worden aangesloten ingangsbuis van de geluidsmodule om de geluidseffecten op het apparaat te synchroniseren. (Afb. 5)

3 AUDIO-UITVOERPOORT

De audio-uitgang kan worden aangesloten op een actieve luidspreker (speciale elektronische drumluidspreker) en grote audioapparatuur. (Afb. 3)

4 AUDIO-INGANGSPOORT

De audio-invoerpoort kan het afspelapparaat van de geluidsbron aansluiten op de modulebox voor weergave (zoals MP3, mobiele telefoon en andere audiosignaalvoer). (Afb. 4)

5 OORTELEFOONPOORT

Door een hoofdtelefoon aan te sluiten, worden de details van de percussie gecontroleerd en worden anderen niet gestoord tijdens het spelen zonder luidsprekers aan te sluiten. (Afb. 5)

6 VERHOOG HAVEN

Via deze poort kunt u een bekken toevoegen voor eenvoudige uitbreiding. (Figuur 6)



BEDIENINGSGIDS

1 VERMOGEN

Steek de DC-stekker in de DC 9V-poort aan de bovenkant van de geluidsmodule. Schuif de POWER-schakelaar naar rechts (vanaf de voorkant gezien) om de drumkit aan te zetten. Om de drumkit uit te schakelen, schuift u de schakelaar naar links.

2 DRUMKIT-SELECTIE

Druk op de KIT-knop om de huidige drumkit weer te geven. Draai aan het parameterwiel of gebruik de knoppen <- /+> om te selecteren welke drumkit. Er zijn 15 drumkits om uit te kiezen - zie de drumkitlijst op pagina 11.

3 METRONOOM

1. Druk op de METRONOME-knop om naar de metronoommodus te gaan.
2. Het scherm geeft de snelheidswaarde weer (standaardsnelheid 120 BPM). Draai aan het parameterwiel of gebruik de +/- knoppen om de metronoomsnelheid te wijzigen. Druk op de CLICK-knop om de metronoom te starten.
3. Druk in de metronoommodus op de SELECT-knop. Het scherm springt naar de metronoomparameter aanpassingsinterface. U kunt op de +/- knoppen drukken om de parameter te selecteren die u wilt aanpassen:
 - A. r (beattype: 2,4,8,16)
 - B. b (telnummer: 01-09)
 - C. L (metronoomvolume: 00 (uit) -31), en draai vervolgens aan het parameterwiel om de parameterinstellingen aan te passen.
4. Nadat de parameters zijn aangepast, drukt u op de SELECT-knop om te bevestigen en de parameter te verlaten interface. Vervolgens
5. Gebruik de klikknop om de metronoom naar wens te starten en stoppen.

4 OEFENFUNCTIE

De 'coach'-coachmodus van dit product kan helpen bij het vaststellen van snelheid, nauwkeurigheid en uithoudingsvermogen, en helpen bij het cultiveren van de oefenfunctie voor een beter ritmegevoel. Boek vooruitgang onder toezicht van de coachmodus!

Druk op de knop "coach" om naar de coachmodus te gaan. In deze modus zijn er drie oefenmodi. Selecteer de praktijk via het datawiel of de knop < + > < - >.

1. Oefenmodus 1: C-1 slagdetectieoefening: sla op de trommel met een vaste snelheid om de nauwkeurigheid van de slag te trainen.
2. Oefenmodus 2: C-2 stille slagmodus: de metronoom laat één sectie klinken en dempt één sectie om de slag nauwkeurigheid zonder metronoomprompt. Het is een geavanceerde versie van oefenmodus 1.
3. Oefenmodus 3: C-3 snelheidsoefening, de metronoom verandert automatisch de snelheid, verhoogd vanaf de langzaamste express naar de snelste, en verminderd dan van de langzaamste express naar de langzaamste snelheid, om zo te oefenen het uithoudingsvermogen van de staking.

5 COACHMODUS

1. De trainingsmodus "coach" van dit product kan helpen bij het vaststellen van snelheid, nauwkeurigheid en uithoudingsvermogen. Druk op COACH om naar de coachmodus te gaan. In deze modus zijn er drie oefenmodi. Gebruik het parameterwiel om te selecteren welke oefenmodus.
 - A. Oefenmodus 1: C-1 oefening voor slagdetectie - sla op de trommel met een vaste snelheid om de nauwkeurigheid van de slag te trainen.
 - B. Oefenmodus 2: C-2 stille slagmodus - de metronoom laat één sectie klinken en dempt één sectie om te trainen als er geen beat is.
 - C. Oefenmodus 3: C-3 speed strike oefenen - de metronoom verandert automatisch de snelheid van de langzaamste naar de snelste en dan van de snelste naar de langzaamste.
2. Zodra de coachingmodus is gekozen, drukt u op de KLIK-knop. De metronoombeats beginnen en dat kun je doen speel mee op de drum om te oefenen.
3. Na vier voorbereidende tellen toont het display:



BEDIENINGSGIDS

(te traag)



(Goed)



(te snel)



4. Zodra u de coachingmodus heeft voltooid, wordt er een score weergegeven van 0-100, waarbij de nauwkeurigheid van de oefening.

C-1-modus: Druk op de SELECT-knop om de parameterinstellingsinterface te openen. U kunt het aantal oefeningen aanpassen sessies naar behoefte (01-32). Het aantal te oefenen sessies bepaalt de lengte van deze oefening.

C-2-modus: Druk op de SELECT-knop om de parameterinstellingsinterface te openen. U kunt het aantal oefeningen aanpassen sessies naar behoefte(04-32). Het aantal te oefenen sessies bepaalt de lengte van deze oefening.

C-3-modus: Druk op de SELECT-knop om de parameterinstellingsinterface te openen. U kunt de snelheid waarmee de BPM wordt aangepast aanpassen wijzigingen (01-09 BPM).

5. Druk nogmaals op de CLICK-knop om de coachmodus te beëindigen.

6 DEMO-SONGS

1. Druk op de SONG-knop om naar de demomodus te gaan. Er zijn 30 demo's om uit te kiezen. Op het scherm wordt het weergegeven huidige demosongnummer (01 -30).

2. Druk op de < > knop om het afspelen van de demosongs te starten. Om het afspelen te stoppen, drukt u nogmaals op de knop < >.

3. Draai aan het parameterwiel of druk op de +/- knoppen om een demosong te selecteren.

4. Druk in de songmodus op de SELECT-knop om naar de interface voor het instellen van de songparameters te gaan. U kunt het drumgeluid aan of uit door aan het parameterwiel te draaien (het drumgeluid staat standaard aan).

5. Druk op de SELECT-knop om te bevestigen en de parameterinterface te verlaten.

7 TROMMELPARAMETERS

1. Druk op de KIT-knop en het scherm geeft 01 (drumkitnummer) weer. Druk op SELECT om de drumparameter in te voeren aanpassingsmodus.

2. Tik op de drum die u wilt aanpassen en druk vervolgens op de +/- knoppen om de parameter voor aanpassing te selecteren. Gevoeligheid S (01-06). Triggerdrempel t (01 - 32). Overspraakdrempel c (01 -32) Herhaalde trigger r (01-32) Drumkracht V (01-03). Drumvolume L (00 - 31).

3. Wijzig de parameters door aan het parameterwiel te draaien en druk lang op de knop - om op te slaan. Het scherm met display SAV om aan te geven dat de parameteraanpassing succesvol is opgeslagen.

4. Om de drumparameters terug te zetten naar de fabriekinstellingen, drukt u lang op de knop + totdat het scherm RES.PLEASE weergeeft
OPMERKING: De parameters voor de 3 tomdrums kunnen niet afzonderlijk worden ingesteld.

8 OPNAMEFUNCTIE

1. Druk op de knop < REC > wanneer het indicatielampje in de statussen "KIT" en "CLICK" staat, en het scherm toont de woorden "REC" in de ademende knipperende staat en gaan naar de opnamevoorbereidingsstatus.

2. Tik op een willekeurige drum en de metronoom klinkt. Op dit moment wordt op het scherm "---" weergegeven terwijl de ademhaling knippert en begint met opnemen.

3. Druk nogmaals op de < REC > toets of < PLAY > toets, de opname stopt en "A-1" wordt op het scherm weergegeven.

4. Druk op < ▶ > om de huidige opname af te spelen, en druk nogmaals om het afspelen te stoppen.

5. Als u zonder kloppen weer in de opnamevoorbereidingsstatus komt, wordt de laatst opgenomen "A-1" afgespeeld.

9 OPSLAAN / RESETTEN

1. Om de parameters op te slaan, drukt u lang op de <-> knop. Het scherm geeft SAV weer.

2. Om de parameters te resetten, drukt u lang op de knop <+>. Het scherm geeft RES res weer.

10 USB-MIDI

Om de MID-functie van de drumkits te gebruiken, sluit u een USB-B-datakabel (niet meegeleverd bij deze drumkit) aan op de bedieningseenheid en verbinding maken met pc/smartphone.



APPENDIX

Timbre

| | | | |
|--------------------------------|--------------------------|---------------------------|------------------------------|
| Trap | 39. Jazz snare-rand | 78. Poprock Tom3 | 116 . Populaire Crash2 |
| 1. Funk-kick | 40 . Blues snare-rand | 79. Rots Tom3 | 117 . Zekering crash2 |
| 2. Originele kick | 41. Populaire snarerand | 80 . Zie Tom3 | 118 . Dancehall-crash 2 |
| 3. Poprock-kick | 42. Zekering snare rand | 81. SnelheidMetal Tom3 | 119. Synthgaze-crash 2 |
| 4. Rots kick | 43. Dancehall snare-rand | 82 . KlassiekeDroge Tom3 | 120 . Standaard crash2 |
| 5. Seesion-kick | 44. Synthgaze snare-rand | 83. Moderne Tom3 | Rijden |
| 6. SpeedMetal-kick | 45 . Standaard snarerand | 84 . Jazztom3 | 121 . Funk rit |
| 7. KlassiekeDry Kick | Tom | 85 . BluesTom3 | 122 . Originele rit |
| 8e. Moderne kick | 46. FunkTom1 | 86 . Populaire Tom3 | 123 . Poprockrit |
| 9. Jazz-kick | 47. Originele Tom1 | 87 . Zekering Tom3 | 124 . Rots rit |
| 10. Blues-kick | 48. Poprocktom1 | 88. Dancehall Tom3 | 125 . Seesion-rit |
| 11. Populaire kick | 49. Rots Tom1 | 89. Synthgaze Tom3 | 126 . SpeedMetal-rit |
| 12. Zekering kick | 50 . Zie Tom1 | 90 . Standaard Tom3 | 127 . Klassieke droge rit |
| 13. Dancehall-kick | 51 . SpeedMetal Tom1 | Botsing | 128 . Moderne rit |
| 14. Synthgaze-kick | 52 . KlassiekeDroge Tom1 | 91. Funk-crash1 | 129 . Jazzrit |
| 15. Standaard trap | 53. Moderne Tom1 | 92 . Originele Crash1 | 130 . Bluesrit |
| Strik | 54. Jazztom1 | 93. Poprockcrash1 | 131 . Populaire rit |
| 16. Funk snare | 55 . BluesTom1 | 94 . Rotscrash1 | 132 . Zekering rit |
| 17. Originele snare | 56. Populaire Tom1 | 95 . Ziesiecrash1 | 133 . Dancehall-rit |
| 18 . Pop-rock snare | 57. Zekering Tom1 | 96. SpeedMetal-crash1 | 134 . Synthgaze-rit |
| 19. Rock snare | 58. Dancehall Tom1 | 97. KlassiekeDry Crash1 | 135 . Standaard rit |
| 20 . Ziesie strik | 59. Synthgaze Tom1 | 98. Moderne crash1 | Hallo |
| 21. SpeedMetal snare | 60 . Standaard Tom1 | 99. Jazzcrash1 | 136 . Funk hihat open |
| 22. Klassieke droge snare | 61. FunkTom2 | 100 . Bluescrash1 | 137 . Originele hihat open |
| 23. Moderne snare | 62 . Originele Tom2 | 101 . Populaire crash1 | 138 . Poprock hihat open |
| 24. Jazz snare | 63. Poprock Tom2 | 102 . Zekering crash1 | 139 . Rock hihat open |
| 25. Blues-snaredrum | 64. Rots Tom2 | 103. Dancehall-crash1 | 140 . Seesion hihat open |
| 26. Populaire snare | 65 . Zie Tom2 | 104 . Synthgaze-crash1 | 141 . SpeedMetal hihat open |
| 27. Zekering Snaar | 66. SnelheidMetal Tom2 | 105 . Standaardcrash1 | 142 . ClassicDry Hi-Hat Open |
| 28. Dancehall-snare | 67. KlassiekeDroge Tom2 | 106. Funk-crash2 | 143 . Moderne hihat open |
| 29. Synthgaze snare | 68. Moderne Tom2 | 107 . Originele Crash2 | 144 . Jazz hihat open |
| 30 . Standaard snare | 69. Jazztom2 | 108. Poprockcrash2 | 145 . Blues hihat open |
| 31. Funk snare-rand | 70 . BluesTom2 | 109. Rotscrash2 | 146 . Populaire hihat open |
| 32. Originele snarerand | 71. Populaire Tom2 | 110 . Ziesiecrash 2 | 147 . Zekering Hi-Hat open |
| 33. Pop-rock snare-rijm | 72. Zekering Tom2 | 111 . SpeedMetal Crash2 | 148 . Dancehall HiHat Open |
| 34. Rock snare-rand | 73. Dancehall Tom2 | 112 . KlassiekeDry Crash2 | 149 . Synthgaze hihat open |
| 35. Seesion Snaredrum | 74 . Synthgaze Tom2 | 113 . Moderne crash2 | 150 . Standaard hihat open |
| 36. SpeedMetal snare-rand | 75 . Standaard Tom2 | 114 . Jazzcrash2 | 151 . Funk HiHat Close |
| 37. Klassieke droge snare-rand | 76 . FunkTom3 | 115 . Bluescrash2 | 152 . Originele Hi-Hat Close |
| 38. Moderne snarerand | 77. Originele Tom3 | | |



APPENDIX

| | | |
|---------------------------------|---------------------------------|-----------------------------|
| 153 . Poprock Hi-Hat Close | 163 . Dancehall HiHat Sluiten | 173. Modern hihatpedaal |
| 154 . Rock hi-hat dichtbij | 164 . Synthgaze Hi-Hat Sluiten | 174 . Jazz hihatpedaal |
| 155 . Seesion Hi-Hat Sluiten | 165 . Standaard hi-hat gesloten | 175 . Blues hihatpedaal |
| 156 . SpeedMetal Hi-Hat Sluiten | 166 . Funk hihatpedaal | 176 . Populair hihatpedaal |
| 157 . ClassicDry Hi-Hat Sluiten | 167 . Origineel hihatpedaal | 177 . Zekering hi-hatpedaal |
| 158 . Moderne hi-hat close | 168 . Poprock hihatpedaal | 178 . Dancehall hihatpedaal |
| 159 . Jazz HiHat Sluiten | 169 . Rock hi-hatpedaal | 179 . Synthgaze hihatpedaal |
| 160 . Blues Hi-Hat Sluiten | 170 . Seesion hihatpedaal | 180 . Standaard hihatpedaal |
| 161 . Populaire Hi-Hat Close | 171 . SpeedMetal hihatpedaal | |
| 162 . Zekering Hi-Hat gesloten | 172 . KlassiekDry hihatpedaal | |

Drum combination timbre

Drumstel van gebruiker

| | | | | |
|-------------|---------------|---------------|------------|--------------|
| 01 Funk | 04 Rock | 07 ClassicDry | 10 Blues | 13 Dancehall |
| 02 Original | 05 Seesion | 08 Modern | 11 Popular | 14 Synthgaze |
| 03 Poprock | 06 SpeedMetal | 09 Jazz | 12 Fuse | 15 Standard |

Demonstratielied

| | | | | | | | |
|----------|----------|----------|----------|----------|----------|----------|----------|
| Lied 001 | Lied 005 | Lied 009 | Lied 013 | Lied 017 | Lied 021 | Lied 025 | Lied 029 |
| Lied 002 | Lied 006 | Lied 010 | Lied 014 | Lied 018 | Lied 022 | Lied 026 | Lied 030 |
| Lied 003 | Lied 007 | Lied 011 | Lied 015 | Lied 019 | Lied 023 | Lied 027 | |
| Lied 004 | Lied 008 | Lied 012 | Lied 016 | Lied 020 | Lied 024 | Lied 028 | |



PRODUCT MAINTENANCE

Careful maintenance and protection of the product, to extend the service life of the product, reduce the fault has a very important role.

1 AVOID HEATING, DAMPNES OR DIRECT SUNLIGHT

Do not over expose the product to direct sunlight, or place it near air conditioning or extremely hot place.

2 DO NOT USE NEAR THE TV OR RADIO

This product may cause video or audio interference to the reception of TV and radio. If this happens, the product should be removed from the TV or radio.

3 NO DILUENTS OR SIMILAR CHEMICALS SHOULD BE USED FOR CLEANING

Clean the product with a soft cloth wetted with weak water solution and neutral detergent. Soak the cloth in a solution and wring it dry until it approaches drying.

4 DO NOT SHAKE, AVOID COLLISION

When moving, the product should be handled carefully and lightly. Violent vibration and collision are strictly prohibited in order to avoid damage to the shell or internal electronic components.



SAFETY PRECAUTIONS

POWER SUPPLY

This product can be powered by standard indoor wall sockets. Please only use the power cord specified in this product. When not in use, please turn off the power supply. When not in use for a long time, pull out the power cord and keep it properly.

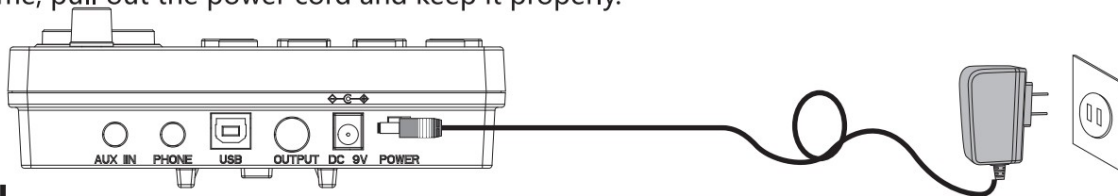

SIGN

To ensure that you use this product safely and correctly, to prevent harm to users and others and financial damage, this manual and products are marked with a series of safety signs. The various signs and their meanings are as follows:

WARNING

This sign indicates that there is a potential risk of death or serious injury if this mark is ignored and the product is mishandled.

BE CAREFUL

This sign indicates that there is a potential danger of injury to personnel or other financial damage if this sign is ignored and the product is operated incorrectly.

EXAMPLE OF LOGO



This triangle sign (Δ) indicates what users should pay attention to. (The left example is careful shocks)



A circular sign (\ominus) with an oblique line indicates prohibitions. The icons in or beside the logo indicate the contents specifically prohibited. (The example on the left is no disassembly)



The round black bottom sign (\odot) indicates what must be observed. The diagrams in this sign indicate the contents of the specific matters that must be observed. (The example on the left is that the power plug must be pulled out of the socket)



SAFETY PRECAUTIONS

WARNING

Smoke, odor, overheating

When the product smokes, smells or overheats, there is a danger of fire and electric shock when it is used continually. In case of the above situation, the following operations should be performed immediately:

1. Turn off the power supply.
2. Pull the plug out of the power outlet.
3. Contact your dealer.

Power cord

1. The improper use of power cord may cause fire and electric shock. The following precautions must be observed:

- The special power cord designated for this product must be used.
- The AC power supply with output voltage within the rated voltage range for household use must be used.
- Do not overload power sockets and extension lines.



2. The improper treatment of power line will lead to its damage or breakage, which will cause fire and electric shock hazards. The following precautions must be observed:

- Do not place or heat heavy objects on power lines.
- Do not attempt to alter or bend the power cord too much.
- Do not twist or pull the power cord.
- If the power cord or plug is damaged, please replace the same type of power cord.



3. Do not touch the power cord and plug with wet hands, otherwise there is a danger of electric shock.



4. Please use the power cord where the water will not splash. Water is in danger of causing fire and electric shock.



5. Never place vases or any other container containing water on this product. Water is dangerous of causing fire and electric shock.



6. Do not allow minors to unplug and touch power lines or connection boards. Minors have no common sense of electricity safety, which may cause electric shock.



BE CAREFUL

The improper use of power cord may cause fire and electric shock. The following precautions must be observed:

- Never put the power cord near the oven or other heat source.
- Do not pull the cable when pulling out of the power socket. The main body of the plug must be grasped.
- The power cord plug must be inserted in the socket to the end.
- Make sure the power supply is off before connecting or disconnecting it.
- When thunderstorms occur or before traveling or other long-term departure, disconnect the power cord from the wall outlet.
- At least once a year, remove the power cord from the wall outlet and clean the dust accumulated around the plug.



Do not burn this product

Do not put this product in the fire, otherwise it will lead to product combustion and explosion of internal electronic components, which will cause fire and personnel injury.



Water and foreign bodies

Water, other liquids and (metal sheets, etc.) entering this product are in danger of causing fire and electric shock. In case of the above situation, the following operations shall be performed immediately:



1. Turn off the power supply.
2. If you are using a power cord for power supply, unplug it from the wall outlet.
3. Contact your distributor.

Disassembly and transformation

Do not disassemble or transform the product in any way, otherwise there is a risk of electric shock, scald or other personal injury. All internal inspection, adjustment and maintenance operations should be entrusted to your distributor.





SAFETY PRECAUTIONS

Falling or colliding

If the product falls or is damaged by strong impact, it will be in danger of causing fire and electric shock. In case of the above situation, the following operations shall be performed immediately:

1. Turn off the power supply.
2. If you are using a power cord for power supply, you need to unplug it from the wall outlet.
3. Contact your distributor.



Plastic bag

Do not let anyone put plastic bags for this product on his head or in his mouth. Otherwise, there is a risk of asphyxia. Families with young children should pay special attention to it.



Keep a distance from the product and the bracket

Climbing the bracket is dangerous of overturning or damage. Families with young children should pay special attention to it.



Put

Avoid placing the product on an uneven surface or any other unstable place. Otherwise, it will cause the product to fall down, which will lead to the risk of injury.



Product Mobility

Before moving this product, you must unplug the power cord plug from the wall outlet and pull out all other cables and connecting wires. Otherwise, it will lead to damage of power or connection wires, resulting in fire and electric shock.



clean

Before cleaning this product, you must unplug the power cord plug from the wall outlet, otherwise there is a risk of fire and electric shock.



Jack

The socket of this product can only be connected to the designated equipment and devices. Connecting non-designated equipment or devices is dangerous of causing fire and electric shock.



Location selection

It should be avoided to place the product in the following places, otherwise there is a risk of fire and electric shock.

- High temperature or dusty places.
- Kitchen or other places with lampblack.
- Where the product is exposed to direct sunlight, or any other place where the product will produce high temperature.



Volume

Don't play music long and loud. Pay special attention when using headphones. Excessive volume can damage your hearing.



Heavy

Do not place heavy objects on this product. Otherwise, the top of the product will be overweight, causing the product to overturn or drop objects on it, which will lead to the risk of injury.



Correct assembly of scaffolds

The incorrect assembly of the bracket may overturn, causing the product to fall off and posing a risk of injury to personnel. Therefore, it must be assembled according to the instructions in the attached installation guide to ensure that the product is properly mounted on its bracket.



| | |
|--|--|
|  | <p>Waarschuwing-Om het risico op letsel te verminderen, moet de gebruiker de handleiding zorgvuldig lezen.</p> |
|  | <p>Dit apparaat voldoet aan Deel 15 van de FCC-regels. Het gebruik is onderworpen aan de volgende twee voorwaarden: (1) Dit apparaat mag geen schadelijke interferentie veroorzaken, en (2) dit apparaat moet alle ontvangen interferentie accepteren, inclusief interferentie die een ongewenste werking kan veroorzaken.</p> |
|  | <p>Dit product valt onder de bepalingen van de Europese richtlijn 2012/19/EG. Het symbool met een doorgestreepte afvalcontainer geeft aan dat het product in de Europese Unie een aparte afvalinzameling vereist. Dit geldt voor het product en alle accessoires die met dit symbool zijn gemarkeerd. Producten die als zodanig gemarkeerd zijn, mogen niet met het normale huisvuil worden weggegooid, maar moeten naar een inzamelpunt voor recycling van elektrische en elektronische apparaten worden gebracht</p> |

Fabrikant: Shanghaimuxinmuyeyouxiangongsi **Adres:**

Shuangchenglu 803nong11hao1602A-1609shi, baoshanqu, shanghai
200000 CN.

Geïmporteerd naar AUS: SIHAO PTY LTD, 1 ROKEVA STREETEASTWOOD NSW
2122 Australië

Geïmporteerd naar de VS: Sanven Technology Ltd., Suite 250, 9166 Anaheim
Place, Rancho Cucamonga, CA 91730



E-CrossStu GmbH
Mainzer Landstr.69, 60329 Frankfurt am Main.



YH CONSULTING LIMITED.
C/O YH Consulting Limited Kantoor 147, Centurion House,
London Road, Staines-upon-Thames, Surrey, TW18 4AX

VEVOR[®]

TOUGH TOOLS, HALF PRICE

**Technische ondersteuning en e-
garantiecertificaat www.vevor.com/support**

VEVOR®

TOUGH TOOLS, HALF PRICE

Teknisk support och e-garanticertifikat

www.vevor.com/support

ELEKTRONISKT TRUMSET

ANVÄNDARMANUAL

MODELL: MD200C

Vi fortsätter att vara engagerade i att ge dig verktyg till konkurrenskraftiga priser.

"Spara halva", "halva priset" eller andra liknande uttryck som används av oss endast representerar en uppskattning av besparingar du kan dra nytta av att köpa vissa verktyg hos oss jämfört med de stora toppmärkena och betyder inte nödvändigtvis att täcka alla kategorier av verktyg erbjuds av oss. Du påminns om att noggrant kontrollera när du gör en beställning hos oss om du verkligen sparar hälften i jämförelse med de främsta varumärkena.

VEVOR[®]
TOUGH TOOLS, HALF PRICE

ELEKTRONISKT TRUMSET

MODELL: MD200C

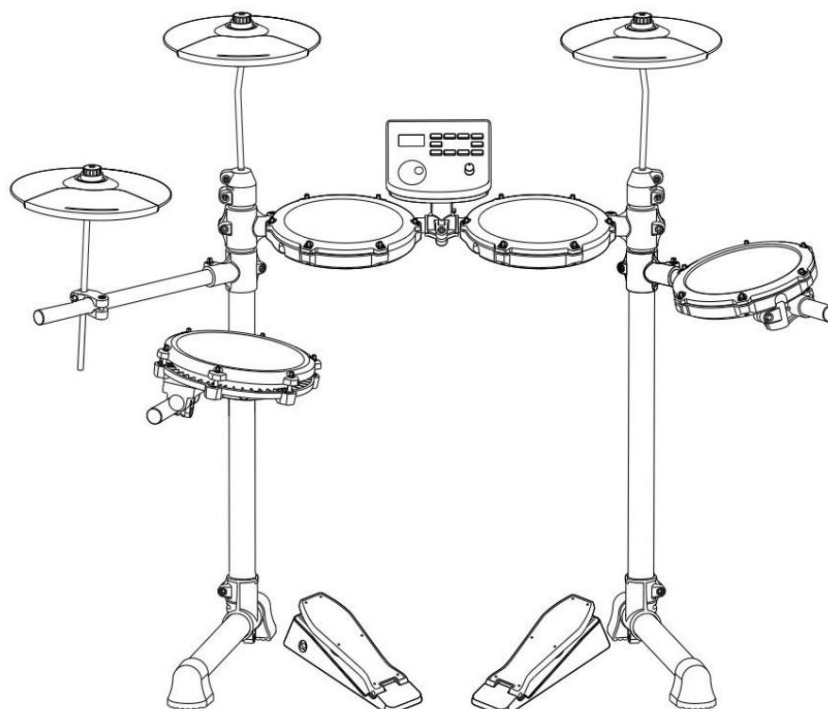

(Bilden är endast för referens, se det faktiska objektet)

BEHÖVS HJÄLP? KONTAKTA OSS!

Har du produktfrågor? Behöver du teknisk support? Du får gärna kontakta oss:

**Teknisk support och e-garanticertifikat [www.vevor.com/
support](http://www.vevor.com/support)**

Detta är den ursprungliga instruktionen, läs alla instruktioner noggrant innan du använder den. VEVOR reserverar sig för en tydlig tolkning av vår användarmanual. Utseendet på produkten är beroende av den produkt du fått. Ursäkta oss att vi inte kommer att informera dig igen om det finns någon teknik eller mjukvaruuppdateringar på vår produkt.



FUNKTION INTRODUKTION

Tack för att du valde vår elektroniska trumma. Elegant och delikat elektronisk trumma är den perfekta kombinationen av modern ny elektronisk teknik. • Innan du använder denna produkt måste du läsa instruktionerna i detalj.

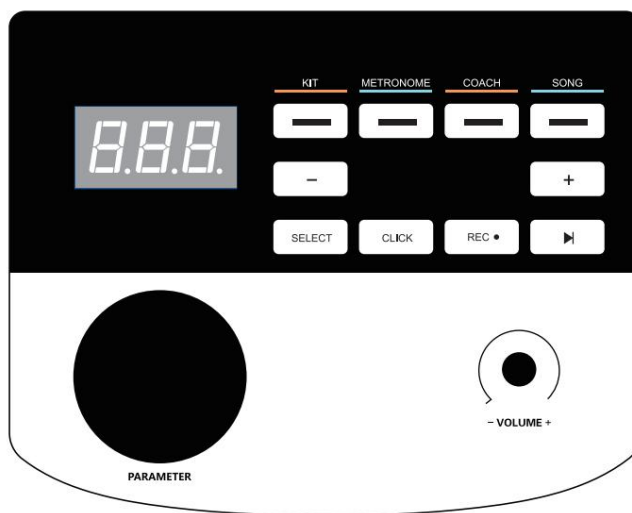

- 15 trumset, 180 klangfärger

- 30 låtar •

stöder justering av känslighetsparametrar för varje trumma • tre inlärningslägen •

hastighetskontroll: 30 ~ 250 slag/min

- metronom: 1-9 typer •

andra funktioner: parameterlagring, återställning och inspelning;

- tresiffrig LED-display; •

gränssnitt: strömförsörjning DC, usbmidi, hörlurar, ljudingång, ljudutgång öka cymbal

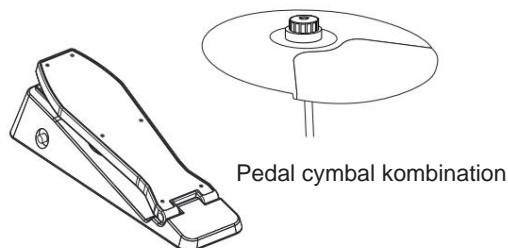

Pedal cymbal kombination

ANMÄRKNING!

- Denna produkt är en elektroakustisk instrumentprodukt. Det är normalt att det är lite ström ljud i högtalaren eller hörlurarna efter påslag.

Håll dig borta från "radio, TV, antennmottagare, router, kylskåp, TV, motor och andra elektriska RF-störningskällor" under användning.

**INNEHÅLL**

| | |
|--|-----------|
| FUNKTIONS INTRODUKTION | 1 |
| INNEHÅLL | 2 |
| INSTALLATIONSGUIDE | 3 |
| KONTROLLERA BILAGADE ARTIKLAR | 3 |
| STÅR RÖRBESLAG | 4 |
| MONTERINGSSTÄLL | 4 |
| INSTALLATION AV DRUM PAN | 5 |
| INSTALLATION AV LJUDMODUL | 5 |
| INSTALLERA CYMBALER, LJUDMODUL, PLATSPEDALER | 6 |
| SÄTTA ANSLUTNINGSKABEL FÖR SLAGDELEN | 7 |
| ILLUSTRATION AV LJUDMODULPORT | 8 |
| ANSLUTNING AV nätsladd | 8 |
| USB MIDI-PORT | 8 |
| LJUDUTGÅNGSPORT | 8 |
| LJUDINGÅNGSPORT | 8 |
| HÖRTELEFONPORT | 8 |
| ANVÄNDARGUIDE | 9 |
| KRAFT | 9 |
| VAL av trumset | 9 |
| METRONOM | 9 |
| ÖVNINGSFUNKTION | 9 |
| TRÄNSLÄGE | 9 |
| DEMO-LÅT | 10 |
| TRUMPARAMETRAR | 10 |
| INSPELNINGSFUNKTION | 10 |
| SPARA / ÅTERSTÄLL | 10 |
| USBMIDI | 10 |
| BILAGA | 11 |
| TRUMTIMBRE | 11 |
| FÖRINSTÄLLDA trumset | 11 |
| ANVÄNDARDEFINIERADE trumset | 11 |
| DEMONSTRATIONSÅNG | 11 |
| PRODUKTUNDERHÅLL | 12 |
| SÄKERHETSÅTGÄRDER | 13 |



INSTALLATIONSGUIDE

ANMÄRKNING!

- Följ instruktionerna och läs noggrant igenom "säkerhetsföreskrifterna" i användarmanualen innan användning .
- Denna produkt måste installeras av en vuxen, låt inte den minderåriga installera den självständigt.

01

Kontrollera de bifogade föremålen

- Efter att ha öppnat förpackningen, kontrollera omedelbart om den innehåller alla föremål. Om några saknas, kontakta din återförsäljare.



Ljudmodul



Modulfäste



Cymbal*3



Tom (3st)



Snara



Trumpinne



Pedal*2



Signalanslutningskabel



Strömadapter

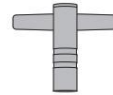

Trumnyckel



Ride/Crash arm



Hi-hat arm



INSTALLATIONSGUIDE

02

Stativ rörkoppling

•Stället ligger i en liten individuell förpackning inuti kartongen.

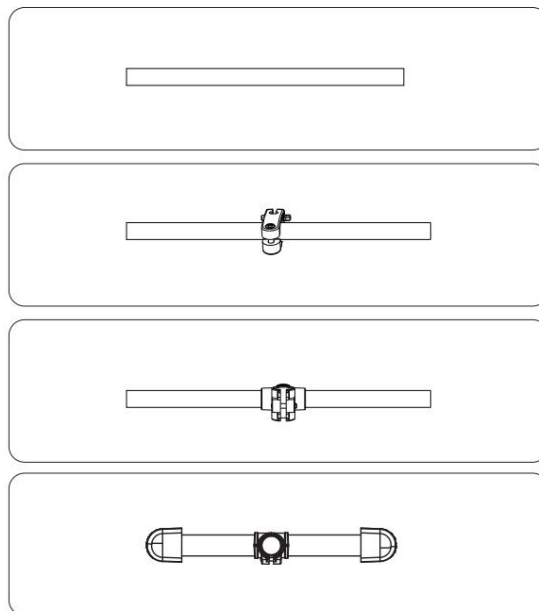
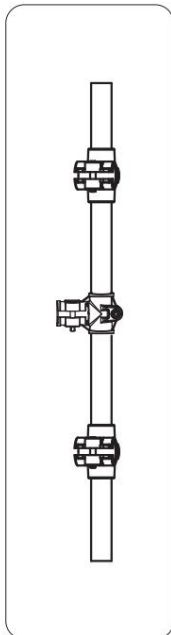
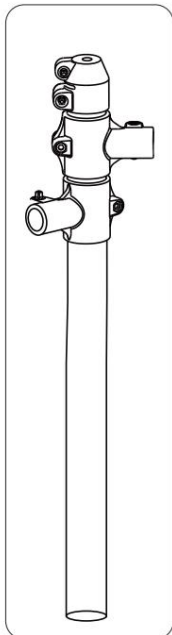
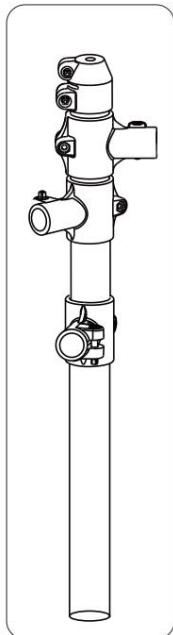

Monteringsstativ

03 • Stativet måste monteras på plats och skruva fast skruvarna med trumnyckeln.

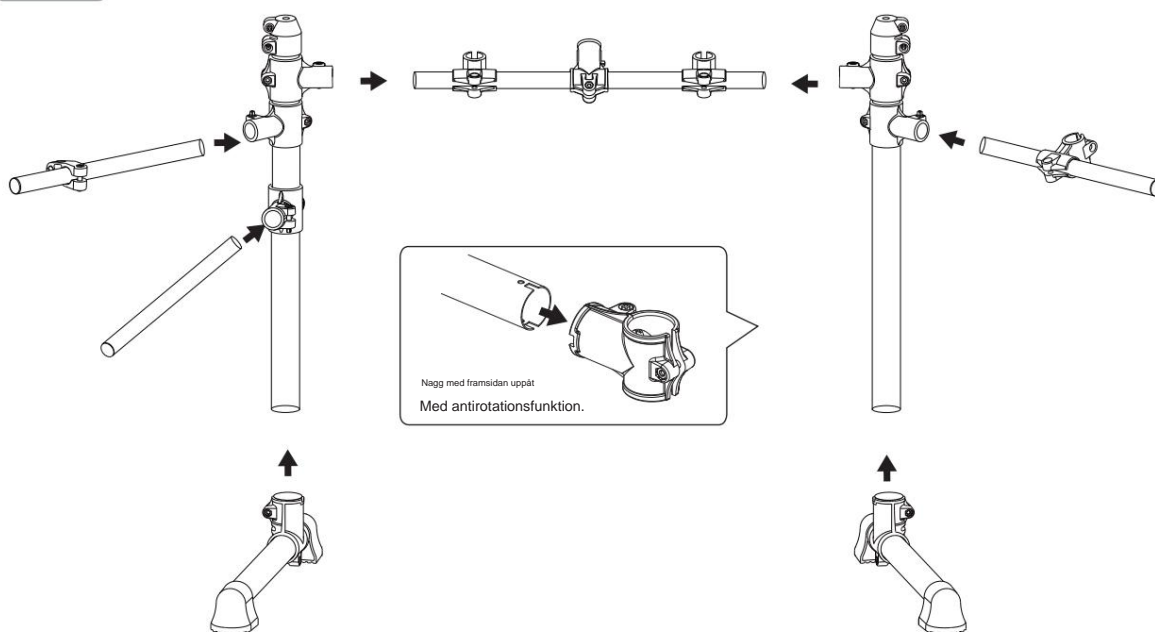



INSTALLATIONSGUIDE

04

Installation av trumma

•Var försiktig och kläm inte fingrarna när du installerar.

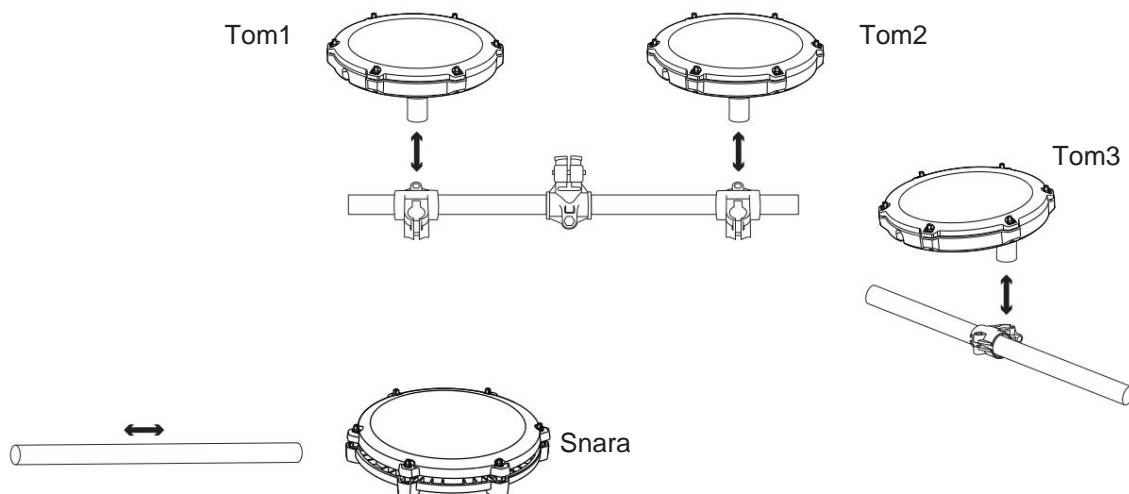

05

Installation av ljudmodul • Montera ihop ljudmodulen med stativet innan du fäster den på trumset.

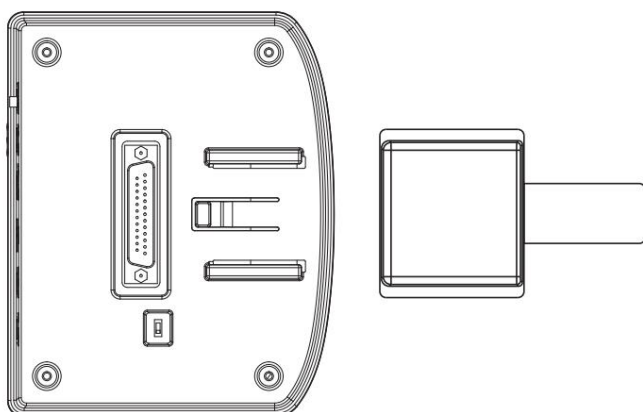

Sätt in huvudboxfästet mot ljudmodulspåret, och du kommer att höra klickbiten dyka upp när du sätter in den i botten.



INSTALLATIONSGUIDE

06

Installera cymbaler, ljudmodul, placera pedaler

- Se till att inte dra åt cymbalen för hårt, lämna lite utrymme så att de kan slingra sig upp och ner.

Installera cymbalen och ljudmodulen på stativet som visas på bilden

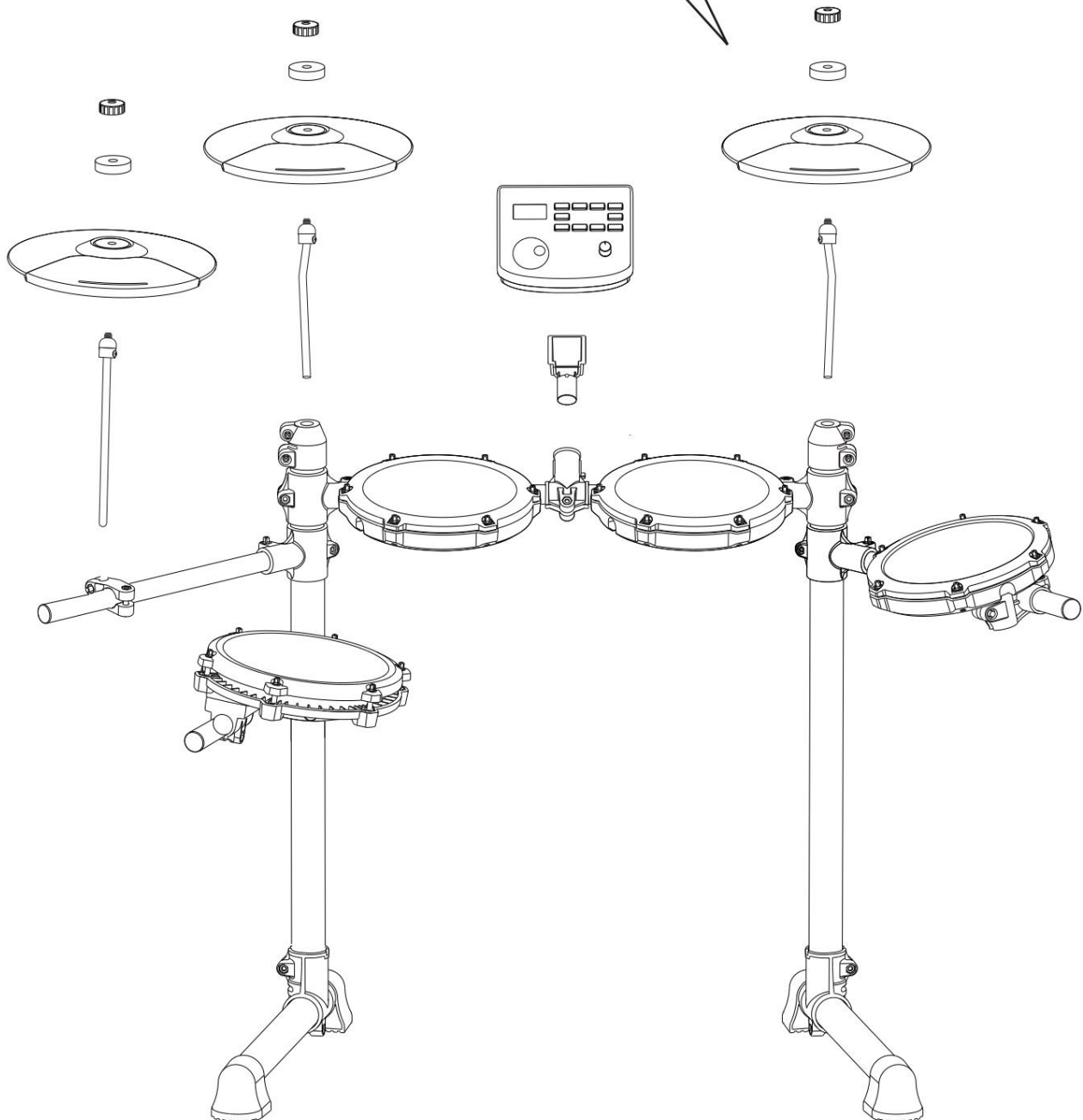
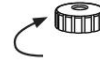



INSTALLATIONSGUIDE

07

Sätt i anslutningskabeln till den träffande delen

- Sätt in anslutningskabeln på plats för att undvika dålig kontakt och sätt in den korrekt enligt bilden i diagrammet.

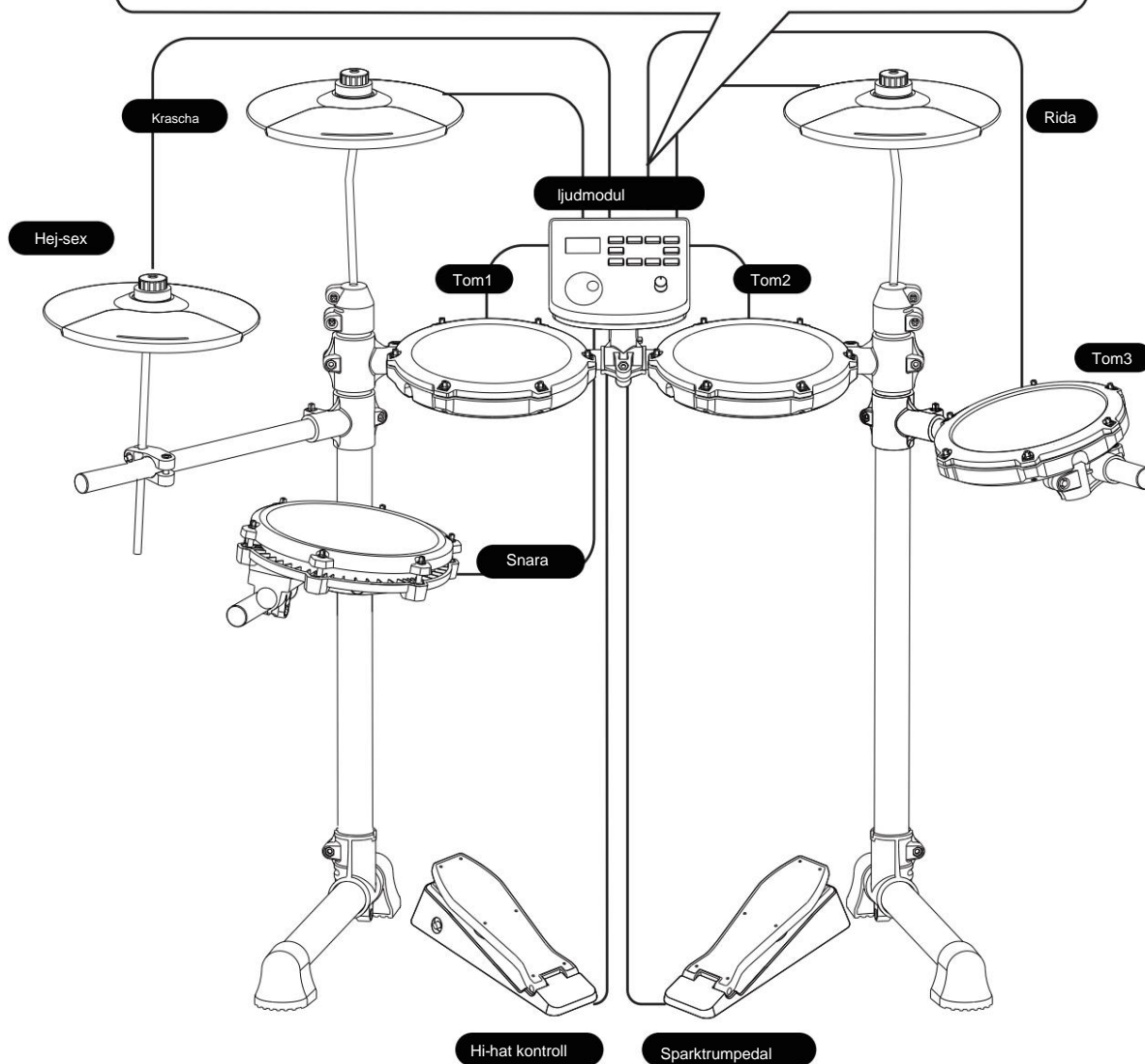
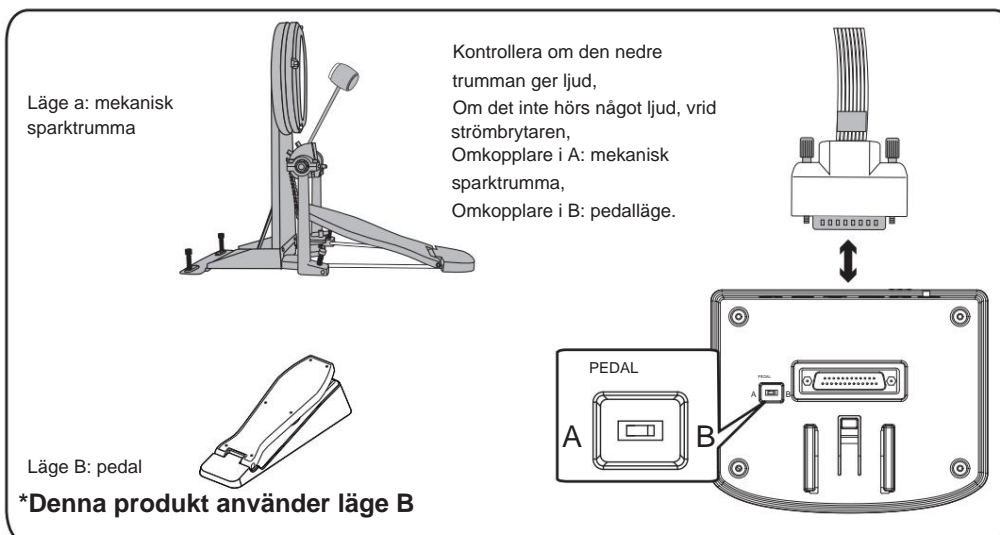
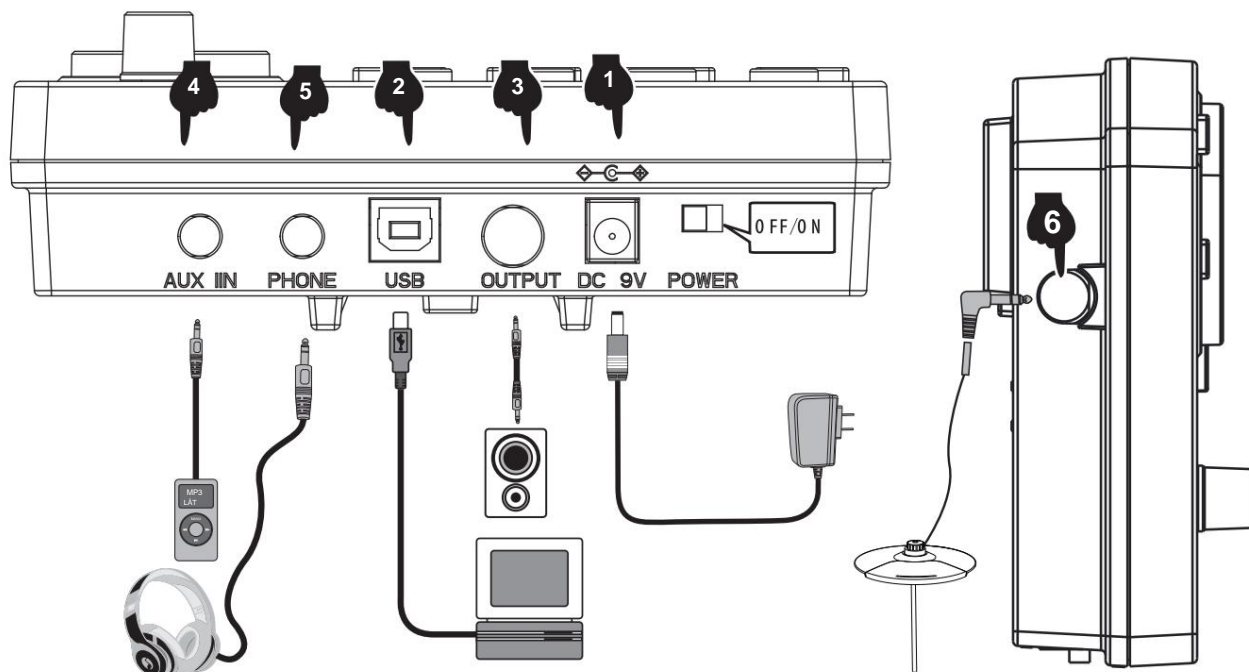



ILLUSTRATION AV LJUDMODULPORT



1 ANSLUTNING AV NÄTSLAD

1. När den används, anslut strömterminalen enligt diagrammet, sätt in strömuttaget på modulboxen vid ena änden och 100-240V hushållsuttag i andra änden. (Figur 1)
2. Om du inte använder den här produkten under en längre tid, vänligen dra ut strömkontakten och förvara den på rätt sätt.

2 USB MIDI-PORTAR

Användningen av elektronisk trumma MIDI USB-gränssnitt kan interagera med musikenheter med MIDI.

1. Genom den förinstallerade musikmjukvaran på datorer och mobiltelefoner kan vi lära oss att spela, komponera musik, butik och andra funktioner. (Fig. 2)
2. När enheten är ansluten till en dator eller mobiltelefon måste enhetens ljudutgång vara ansluten till ljudet ljudmodulens ingångsuttag för att synkronisera ljudeffekterna på enheten. (Fig. 5)

3 LJUDUTGÅNGSPORT

Ljudutgång kan anslutas till aktiv högtalare (särskild elektronisk trumhögtalare) och stor ljudutrustning. (Fig. 3)

4 AUDIO INPUT PORT

Ljudingångsport kan ansluta ljudkällans uppspelningsenhet till modulboxen för uppspelning (som MP3, mobiltelefon och annan ljudsignalingång). (Fig. 4)

5 HÖRTELEFONPORT

Anslutande hörlurar övervakar detaljerna i slagverk och stör inte andra när man spelar utan att ansluta högtalare. (Fig. 5)

6 ÖKA PORT

Denna port låter dig lägga till en cymbal för enkel expansion. (Figur 6)



ANVÄNDARGUIDE

1 STRÖM

Sätt i DC-kontakten i DC 9V-porten på toppen av ljudmodulen. Skjut POWER-omkopplaren åt höger (sett framifrån) för att starta trumset. För att stänga av trumset, skjut omkopplaren åt vänster.

2 VAL AV trumset

Tryck på KIT-knappen för att visa det aktuella trumsetet. Vrid på parameterhjulet eller använd <- /+>-knapparna för att välja önskat trumset. Det finns 15 trumset att välja mellan - se trumsetlistan på sidan 11.

3 METRONOM

1. Tryck på METRONOME-knappen för att gå in i metronomläget.
2. Skärmen visar hastighetsvärdet (120 BPM standardhastighet). Vrid på parameterhjulet eller använd +/- knappar för att ändra metronomhastigheten. Tryck på CLICK-knappen för att starta metronomen.
3. Tryck på SELECT-knappen i metronomläge, så hoppar skärmen till metronomparametern justeringsgränssnitt. Du kan trycka på +/- knapparna för att välja den parameter du vill justera:
 - A. ryslagtyp: 2,4,8,16y
 - B. b (slagnummer: 01-09)
 - C. L(metronomvolym: 00 (av) -31), och vrid sedan på parameterhjulet för att justera parameterinställningarna.
4. När parametrarna har justerats, tryck på SELECT-knappen för att bekräfta och avsluta parametern gränssnitt. Sedan
5. Använd klickknappen för att starta och stoppa metronomen enligt önskemål.

4 ÖVNINGSFUNKTION

Coach-tränarläget för denna produkt kan hjälpa till att etablera snabbhet, noggrannhet och uthållighet, och hjälpa till att odla öva funktion av en bättre känsla för rytm. Gör framsteg under överinseende av tränarläget "coach"!

Tryck på "coach"-knappen för att gå in i coachläget. I detta läge finns det tre övningslägen. Välj praktiken läge via datahjulet eller knappen < + > < - >.

1. Träningsläge 1: C-1 taktdekteteringsövning: slå på trumman med en fast hastighet för att träna slagets noggrannhet.
2. Övningsläge 2: C-2 tyst slagläge: metronomen låter en sektion och tystar en sektion för att träna slagnoggrannhet utan metronomprompt. Det är en avancerad version av övningsläge 1.
3. Övningsläge 3: C-3 speed strike övning, metronomen kommer automatiskt att ändra hastigheten, öka från långsammaste till snabbaste, och sedan minska från långsammaste till långsammaste hastighet, för att öva på slå uthållighet.

5 COACH-LÄGE

1. Träningsläget "coach" för denna produkt kan hjälpa till att fastställa hastighet, noggrannhet och uthållighet. Tryck på COACH knappen för att gå in i tränarläget. I detta läge finns det tre övningslägen. Använd parameterhjulet för att välja vilket övningsläge.
 - A. Träningsläge 1:C-1 taktdekteteringsövning - slå på trumman med en fast hastighet för att träna slagets noggrannhet.
 - B. Övningsläge 2:C-2 tyst slagläge - metronomen låter en sektion och tystar en sektion för att träna när det inte finns något slag.
 - C. Övningsläge 3:C-3 speed strike övning - metronomen ändrar automatiskt hastigheten från den långsammaste till den snabbaste och sedan den snabbaste till den långsammaste.
2. När coachningsläget har valts, tryck på KLICK-knappen. Metronomslagen börjar och du kan spela med på trumman för att träna.
3. Efter fyra preliminära slag visar displayen:



ANVÄNDARGUIDE

(för långsam)



(Bra)



(för snabbt)



4. När du har slutfört coachningsläget kommer ett resultat att visas från 0-100 som utvärderar noggrannheten av övningen.

C-1-läge: Tryck på SELECT-knappen för att gå in i parameterinställningsgränssnittet. Du kan anpassa antalet övningar sessioner efter behov (01-32). Antalet träningspass avgör längden på denna övning.

C-2-läge: Tryck på SELECT-knappen för att gå in i parameterinställningsgränssnittet. Du kan justera antalet övningar sessioner efter behov (04-32). Antalet träningspass avgör längden på denna övning.

C-3-läge: Tryck på SELECT-knappen för att gå in i parameterinställningsgränssnittet. Du kan justera hastigheten med vilken BPM ändringar (01-09 BPM).

5. Tryck på KLICK-knappen igen för att avsluta coachläget.

6 DEMO-LÅTAR

1. Tryck på SONG-knappen för att gå in i demoläget, det finns 30 demos att välja mellan. Skärmen kommer att visa aktuellt demolåtnummer (01 -30).
2. Tryck på <>-knappen för att börja spela demolåtarna. För att stoppa uppspelningen, tryck på <>-knappen igen.
3. Vrid på parameterhjulet eller tryck på +/- knapparna för att välja en demosong.
4. Tryck på SELECT-knappen i sångläge för att hoppa till sångparameterinställningsgränssnittet. Du kan vrida på trumljudet på eller av genom att vrida på parameterhjulet (trumljudet är på som standard).
5. Tryck på SELECT-knappen för att bekräfta och avsluta parametergränssnittet.

7 TRUMPARAMETRAR

1. Tryck på KIT-knappen och skärmen visar 01 (trumsetnummer). Tryck på SELECT för att ange trumparametern justeringsläge.
2. Tryck på trumman du vill justera och tryck sedan på +/- knapparna för att välja parametern för justering. Känslighet S (01-06). Triggertröskel t(01 - 32). Överhörningströskel c (01 -32) Upprepad trigger r(01-32) Trumkraft V(01-03). Trumvolym L (00 - 31).
3. Ändra parametrarna genom att vrida på parameterhjulet och trycka länge på --knappen för att spara. Skärmen med display SAV för att indikera att parameterjusteringen har sparats.
4. För att återställa trumparametrarna till fabriksinställningarna, tryck länge på ++knappen tills skärmen visar RES.PLEASE
OBS: Parametrarna för 3 tom-trummorna kan inte ställas in individuellt.

8 INSPELNINGSFUNKTION

1. Tryck på knappen < REC > när indikatorlampan är i lägena "KIT" och "CLICK", och skärmen visar orden "REC" i andningsblinkande tillstånd, går in i inspelningsförberedelseläge.
2. Tryck på valfri trumma och metronomen låter. Vid denna tidpunkt visar skärmen "---" i det blinkande andningsläget och börjar spela in.
3. Tryck på knappen < REC > eller < PLAY > igen, inspelningen stoppas och "A-1" visas på skärmen.
4. Tryck på < ▶ > för att börja spela den aktuella inspelningen och tryck igen för att stoppa uppspelningen.
5. Om du går in i inspelningsförberedelseläget igen utan att knacka, spelas "A-1" som spelades in senast.

9 SPARA / ÅTERSTÄLL

1. För att spara parametrar, tryck länge på <->-knappen och skärmen kommer att visa SAV.
2. För att återställa parametrar, tryck länge på <+>-knappen och skärmen visar RES res.

10 USBMIDI

För att använda trumseten MID-funktion ansluter du aUSB-B-datakabeln (medföljer inte detta trumset) i kontrollenheten och ansluta till PC/Smartphone.

**APPENDIX****Timbre**

| | | | |
|---------------------------|--------------------------|-------------------------|------------------------------|
| Sparka | 39 . Jazz Snare Rim | 78 . Poprock Tom3 | 116 . Populär Crash2 |
| 1 . Funk Kick | 40 . Blues Snare Rim | 79 . Rock Tom3 | 117 . Fuse Crash2 |
| 2 . Original Kick | 41 . Populära Snare Rim | 80 . Sesion Tom3 | 118 . Dancehall Crash2 |
| 3 . Poprock Kick | 42 . Fuse Snare Rim | 81 . SpeedMetal Tom3 | 119 . Synthgaze Crash2 |
| 4 . Rock Kick | 43 . Dancehall Snare Rim | 82 . ClassicDry Tom3 | 120 . Standard Crash2 |
| 5 . Sesion Kick | 44 . Synthgaze Snare Rim | 83 . Modern Tom3 | Rida |
| 6 . SpeedMetal Kick | 45 . Standard Snare Rim | 84 . Jazz Tom3 | 121 . Funk Ride |
| 7 . ClassicDry Kick | Tom | 85 . Blues Tom3 | 122 . Originaltritt |
| 8:a. Modern kick | 46 . Funk Tom1 | 86 . Populära Tom3 | 123 . Pop Rock Ride |
| 9 . Jazz Kick | 47 . Original Tom1 | 87 . Fuse Tom3 | 124 . Rock Ride |
| 10 . Blues Kick | 48 . Poprock Tom1 | 88 . Dancehall Tom3 | 125 . Seesion Ride |
| 11 . Populär Kick | 49 . Rock Tom1 | 89 . Synthgaze Tom3 | 126 . SpeedMetal Ride |
| 12 . Fuse Kick | 50 . Sesion Tom1 | 90 . Standard Tom3 | 127 . ClassicDry Ride |
| 13 . Dancehall Kick | 51 . SpeedMetal Tom1 | Krascha | 128 . Modern Ride |
| 14 . Synthgaze Kick | 52 . ClassicDry Tom1 | 91 . Funk Crash1 | 129 . Jazztritt |
| 15 . Standard Kick | 53 . Modern Tom1 | 92 . Original Crash1 | 130 . Blues Ride |
| Snara | 54 . Jazz Tom1 | 93 . Pop Rock Crash1 | 131 . Populär åktur |
| 16 . Funk Snare | 55 . Blues Tom1 | 94 . Rock Crash1 | 132 . Fuse Ride |
| 17 . Original Snare | 56 . Populära Tom1 | 95 . Sesion Crash1 | 133 . Dancehall Ride |
| 18 . Pop Rock Snare | 57 . Säkring Tom1 | 96 . SpeedMetal Crash1 | 134 . Synthgaze Ride |
| 19 . Rock Snare | 58 . Dancehall Tom1 | 97 . ClassicDry Crash1 | 135 . Standardritt |
| 20 . Seesion Snare | 59 . Synthgaze Tom1 | 98 . Modern Crash1 | HiHat |
| 21 . SpeedMetal Snare | 60 . Standard Tom1 | 99 . Jazzkrasch1 | 136 . Funk Hi-Hat Open |
| 22 . ClassicDry Snare | 61 . Funk Tom2 | 100 . Blues Crash1 | 137 . Original Hi-Hat Open |
| 23 . Modern Snare | 62 . Original Tom2 | 101 . Populär Crash1 | 138 . Pop Rock Hi-Hat Open |
| 24 . Jazz Snare | 63 . Poprock Tom2 | 102 . Fuse Crash1 | 139 . Rock Hi-Hat Open |
| 25 . Blues snara | 64 . Rock Tom2 | 103 . Dancehall Crash1 | 140 . Seesion Hi-Hat Open |
| 26 . Populär snara | 65 . Sesion Tom2 | 104 . Synthgaze Crash1 | 141 . SpeedMetal Hi-Hat Open |
| 27 . Fuse Snare | 66 . SpeedMetal Tom2 | 105 . Standardkrasch1 | 142 . ClassicDry Hi-Hat Open |
| 28 . Dancehall Snare | 67 . ClassicDry Tom2 | 106 . Funk Crash2 | 143 . Modern Hi-Hat Open |
| 29 . Synthgaze Snare | 68 . Modern Tom2 | 107 . Original Crash2 | 144 . Jazz Hi-Hat Open |
| 30 . Standard Snare | 69 . Jazz Tom2 | 108 . Poprock Crash2 | 145 . Blues Hi-Hat Open |
| 31 . Funk Snare Rim | 70 . Blues Tom2 | 109 . Rock Crash2 | 146 . Populära Hi-Hat Open |
| 32 . Original Snare Rim | 71 . Populära Tom2 | 110 . Sesion Crash2 | 147 . Fuse Hi-Hat Open |
| 33 . Pop Rock Snare Rhyme | 72 . Fuse Tom2 | 111 . SpeedMetal Crash2 | 148 . Dancehall Hi-Hat Open |
| 34 . Rock Snare Rim | 73 . Dancehall Tom2 | 112 . ClassicDry Crash2 | 149 . Synthgaze Hi-Hat Open |
| 35 . Seesion Snare Rim | 74 . Synthgaze Tom2 | 113 . Modern Crash2 | 150 . Standard Hi-Hat Open |
| 36 . SpeedMetal Snare Rim | 75 . Standard Tom2 | 114 . Jazzkrasch 2 | 151 . Funk Hi-Hat Close |
| 37 . ClassicDry Snare Rim | 76 . Funk Tom3 | 115 . Blues Crash2 | 152 . Original Hi-Hat Close |
| 38 . Modern Snare Rim | 77 . Original Tom3 | | |



APPENDIX

| | | |
|-------------------------------|-------------------------------|------------------------------|
| 153 . Poprock Hi-Hat Stäng | 163 . Dancehall Hi-Hat Close | 173 . Modern hi-hatpedal |
| 154 . Rock Hi-Hat Close | 164 . Synthgaze Hi-Hat Close | 174 . Jazz Hi-Hat Pedal |
| 155 . Seesion Hi-Hat Stäng | 165 . Standard Hi-Hat Stäng | 175 . Blues Hi-Hat Pedal |
| 156 . SpeedMetal Hi-Hat Stäng | 166 . Funk Hi-Hat Pedal | 176 . Populär Hi-Hat Pedal |
| 157 . ClassicDry Hi-Hat Close | 167 . Original Hi-Hat Pedal | 177 . Fuse Hi-Hat Pedal |
| 158 . Modern Hi-Hat Close | 168 . Pop Rock Hi-Hat Pedal | 178 . Dancehall Hi-Hat Pedal |
| 159 . Jazz Hi-Hat Close | 169 . Rock Hi-Hat Pedal | 179 . Synthgaze Hi-Hat Pedal |
| 160 . Blues Hi-Hat Stäng | 170 . Seesion Hi-Hat Pedal | 180 . Standard Hi-Hat Pedal |
| 161 . Populära Hi-Hat Close | 171 . SpeedMetal Hi-Hat Pedal | |
| 162 . Säkring Hi-Hat Stäng | 172 . ClassicDry Hi-Hat Pedal | |

Drum combination timbre

Användar trumset

| | | | | |
|-------------|---------------|---------------|------------|--------------|
| 01 Funk | 04 Rock | 07 ClassicDry | 10 Blues | 13 Dancehall |
| 02 Original | 05 Seesion | 08 Modern | 11 Popular | 14 Synthgaze |
| 03 Poprock | 06 SpeedMetal | 09 Jazz | 12 Fuse | 15 Standard |

Demonstration låt

| | | | | | | | |
|-----------|---------|-----------|---------|---------|----------|----------|----------|
| Låten 001 | Låt 005 | Låt 009 | Låt 013 | Låt 017 | Sång 021 | Sång 025 | Sång 029 |
| Låten 002 | Låt 006 | Låten 010 | Låt 014 | Låt 018 | Sång 022 | Sång 026 | Sång 030 |
| Låten 003 | Låt 007 | Låten 011 | Låt 015 | Låt 019 | Sång 023 | Sång 027 | |
| Låt 004 | Låt 008 | Låten 012 | Låt 016 | Låt 020 | Sång 024 | Sång 028 | |



PRODUCT MAINTENANCE

Careful maintenance and protection of the product, to extend the service life of the product, reduce the fault has a very important role.

1 AVOID HEATING, DAMPNESS OR DIRECT SUNLIGHT

Do not over expose the product to direct sunlight, or place it near air conditioning or extremely hot place.

2 DO NOT USE NEAR THE TV OR RADIO

This product may cause video or audio interference to the reception of TV and radio. If this happens, the product should be removed from the TV or radio.

3 NO DILUENTS OR SIMILAR CHEMICALS SHOULD BE USED FOR CLEANING

Clean the product with a soft cloth wetted with weak water solution and neutral detergent. Soak the cloth in a solution and wring it dry until it approaches drying.

4 DO NOT SHAKE, AVOID COLLISION

When moving, the product should be handled carefully and lightly. Violent vibration and collision are strictly prohibited in order to avoid damage to the shell or internal electronic components.



SAFETY PRECAUTIONS

POWER SUPPLY

This product can be powered by standard indoor wall sockets. Please only use the power cord specified in this product. When not in use, please turn off the power supply. When not in use for a long time, pull out the power cord and keep it properly.

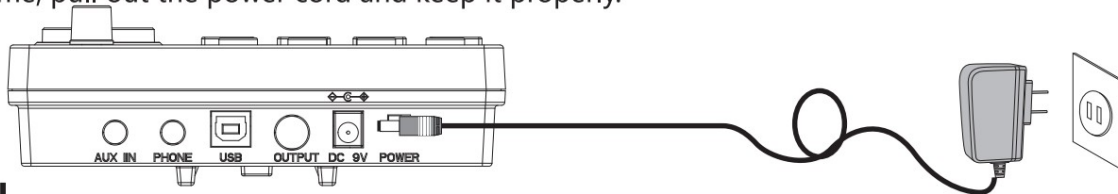

SIGN

To ensure that you use this product safely and correctly, to prevent harm to users and others and financial damage, this manual and products are marked with a series of safety signs. The various signs and their meanings are as follows:

WARNING

This sign indicates that there is a potential risk of death or serious injury if this mark is ignored and the product is mishandled.

BE CAREFUL

This sign indicates that there is a potential danger of injury to personnel or other financial damage if this sign is ignored and the product is operated incorrectly.

EXAMPLE OF LOGO



This triangle sign (Δ) indicates what users should pay attention to. (The left example is careful shocks)



A circular sign (\ominus) with an oblique line indicates prohibitions. The icons in or beside the logo indicate the contents specifically prohibited. (The example on the left is no disassembly)



The round black bottom sign (\odot) indicates what must be observed. The diagrams in this sign indicate the contents of the specific matters that must be observed. (The example on the left is that the power plug must be pulled out of the socket)



SAFETY PRECAUTIONS

WARNING

Smoke, odor, overheating

When the product smokes, smells or overheats, there is a danger of fire and electric shock when it is used continually. In case of the above situation, the following operations should be performed immediately:

1. Turn off the power supply.
2. Pull the plug out of the power outlet.
3. Contact your dealer.

Power cord

1. The improper use of power cord may cause fire and electric shock. The following precautions must be observed:

- The special power cord designated for this product must be used.
- The AC power supply with output voltage within the rated voltage range for household use must be used.
- Do not overload power sockets and extension lines.



2. The improper treatment of power line will lead to its damage or breakage, which will cause fire and electric shock hazards. The following precautions must be observed:

- Do not place or heat heavy objects on power lines.
- Do not attempt to alter or bend the power cord too much.
- Do not twist or pull the power cord.
- If the power cord or plug is damaged, please replace the same type of power cord.



3. Do not touch the power cord and plug with wet hands, otherwise there is a danger of electric shock.



4. Please use the power cord where the water will not splash. Water is in danger of causing fire and electric shock.



5. Never place vases or any other container containing water on this product. Water is dangerous of causing fire and electric shock.



6. Do not allow minors to unplug and touch power lines or connection boards. Minors have no common sense of electricity safety, which may cause electric shock.



BE CAREFUL

The improper use of power cord may cause fire and electric shock. The following precautions must be observed:

- Never put the power cord near the oven or other heat source.
- Do not pull the cable when pulling out of the power socket. The main body of the plug must be grasped.
- The power cord plug must be inserted in the socket to the end.
- Make sure the power supply is off before connecting or disconnecting it.
- When thunderstorms occur or before traveling or other long-term departure, disconnect the power cord from the wall outlet.
- At least once a year, remove the power cord from the wall outlet and clean the dust accumulated around the plug.



Do not burn this product

Do not put this product in the fire, otherwise it will lead to product combustion and explosion of internal electronic components, which will cause fire and personnel injury.



Water and foreign bodies

Water, other liquids and (metal sheets, etc.) entering this product are in danger of causing fire and electric shock. In case of the above situation, the following operations shall be performed immediately:



1. Turn off the power supply.
2. If you are using a power cord for power supply, unplug it from the wall outlet.
3. Contact your distributor.

Disassembly and transformation

Do not disassemble or transform the product in any way, otherwise there is a risk of electric shock, scald or other personal injury. All internal inspection, adjustment and maintenance operations should be entrusted to your distributor.





SAFETY PRECAUTIONS

Falling or colliding

If the product falls or is damaged by strong impact, it will be in danger of causing fire and electric shock. In case of the above situation, the following operations shall be performed immediately:

1. Turn off the power supply.
2. If you are using a power cord for power supply, you need to unplug it from the wall outlet.
3. Contact your distributor.



Plastic bag

Do not let anyone put plastic bags for this product on his head or in his mouth. Otherwise, there is a risk of asphyxia. Families with young children should pay special attention to it.



Keep a distance from the product and the bracket

Climbing the bracket is dangerous of overturning or damage. Families with young children should pay special attention to it.



Put

Avoid placing the product on an uneven surface or any other unstable place. Otherwise, it will cause the product to fall down, which will lead to the risk of injury.



Product Mobility

Before moving this product, you must unplug the power cord plug from the wall outlet and pull out all other cables and connecting wires. Otherwise, it will lead to damage of power or connection wires, resulting in fire and electric shock.



clean

Before cleaning this product, you must unplug the power cord plug from the wall outlet, otherwise there is a risk of fire and electric shock.



Jack

The socket of this product can only be connected to the designated equipment and devices. Connecting non-designated equipment or devices is dangerous of causing fire and electric shock.



Location selection

It should be avoided to place the product in the following places, otherwise there is a risk of fire and electric shock.

- High temperature or dusty places.
- Kitchen or other places with lampblack.
- Where the product is exposed to direct sunlight, or any other place where the product will produce high temperature.



Volume

Don't play music long and loud. Pay special attention when using headphones. Excessive volume can damage your hearing.



Heavy



Do not place heavy objects on this product. Otherwise, the top of the product will be overweight, causing the product to overturn or drop objects on it, which will lead to the risk of injury.



Correct assembly of scaffolds

The incorrect assembly of the bracket may overturn, causing the product to fall off and posing a risk of injury to personnel. Therefore, it must be assembled according to the instructions in the attached installation guide to ensure that the product is properly mounted on its bracket.



| | |
|--|---|
|  | <p>Varning - För att minska risken för skada måste användaren läsa instruktionerna noggrant.</p> |
|  | <p>Denna enhet uppfyller del 15 av FCC-reglerna. Driften är föremål för följande två villkor: (1) Den här enheten får inte orsaka skadliga störningar och (2) den här enheten måste acceptera alla mottagna störningar, inklusive störningar som kan orsaka oönskad funktion.</p> |
|  | <p>Denna produkt omfattas av bestämmelserna i det europeiska direktivet 2012/19/EC. Symbolen som visar en soptunna korsad anger att produkten kräver separat sophämtning i EU. Detta gäller för produkten och alla tillbehör märkta med denna symbol. Produkter märkta som sådana får inte slängas tillsammans med vanligt hushållsavfall, utan måste lämnas till en insamlingsplats för återvinning av elektriska och elektroniska apparater</p> |

Tillverkare: Shanghaimuxinmuyeyouxiangongsi

Adress: Shuangchenglu 803nong11hao1602A-1609shi, baoshanqu, shanghai 200000 CN.

Importerad till AUS: SIHAO PTY LTD, 1 ROKEVA STREETEASTWOOD NSW 2122 Australien

Importerad till USA: Sanven Technology Ltd., Suite 250, 9166 Anaheim Place, Rancho Cucamonga, CA 91730



E-CrossStu GmbH
Mainzer Landstr.69, 60329 Frankfurt am Main.



YH CONSULTING LIMITED.
C/O YH Consulting Limited Office 147, Centurion House,
London Road, Staines-upon-Thames, Surrey, TW18 4AX

VEVOR[®]

TOUGH TOOLS, HALF PRICE

Teknisk support och e-garanticertifikat

www.vevor.com/support