



Russell Hobbs



DESIRE MATTE BLACK HAND MIXER

2 YEAR WARRANTY

RHMX5BLK

RHMX5BLK_IB_RB_FA_030820
Part No. T22-9001946

INSTRUCTIONS & WARRANTY



IMPORTANT SAFEGUARDS

When using this appliance, basic safety precautions should always be followed, including the following:

When using this appliance, basic safety precautions should always be followed, including the following:

Read all instructions before, and follow whilst using this appliance.

1. To protect against electrical hazards, do not immerse the power cord, plug or appliance in water or other liquid.
2. Do not use this appliance near bathtubs, showers, basins or other vessels containing water.
3. Do not use outdoors.
4. Do not let cord hang over edge of table surfaces or counter.
5. Do not let cord contact hot surface, including the stove.
6. This appliance is not intended for use by persons (including children) with reduced physical, sensory or mental capabilities, or lack of experience and knowledge, unless they have been given supervision or instruction concerning use of the appliance by a person responsible for their safety.
7. Misuse of the appliance may cause injury.
8. Do not reach into the mixing bowl or place fingers or utensils in the vicinity of the beaters/dough hooks whilst the mixer is in operation.
9. Remove the beaters/dough hooks from the Hand Mixer before cleaning.
10. After switching off the mixer, always wait until the motor has come to a full stop before handling the attachments.
11. Do not operate the appliance for more than 3 minutes at a time. Allow 5 minutes rest before next use to allow the motor to cool.
12. Do not use attachments or accessories other than those supplied with this appliance.
13. Do not place the Hand Mixer on or near hot surfaces.
14. Ensure the switch is in the "OFF" position after each use of the Hand Mixer. Make sure the motor stops completely before disassembling.
15. Always turn off and unplug the appliance from the power outlet when not in use, before fitting or removing attachments and before cleaning the appliance.
16. This appliance is NOT a toy. Children should be supervised to ensure they do NOT play with this appliance.
17. Always follow the instructions when using this appliance.
18. Always clean the appliance after use.
19. Please ensure all detachable parts are completely dry after cleaning before re-assembling the appliance for next use.
20. If the power cord is damaged, it must be replaced by the manufacturer or similarly qualified person in order to avoid hazard.
21. Do not operate this appliance with a damaged cord/plug or after the appliance has malfunctioned, or been dropped or damaged in any manner. Contact Customer Service for examination, adjustment, repair or replacement.
22. To disconnect, ensure the appliance switch is set to Off, turn off wall power outlet, then grasp and pull the plug from the wall outlet. Never pull by the cord.
23. Misuse may cause injury.
24. Do not attempt to defeat any safety interlock mechanisms.
25. Do not leave the appliance unattended when in use.
26. Do not use the appliance for other than its intended purpose.



27. Do not use on an inclined plane or unstable surface.
28. For added safety, electrical appliances should be connected to a power outlet that is protected by a residual current device (RCD), also often referred to as a 'Safety Switch'. Your switchboard may already incorporate an RCD. If unsure, call an electrician for verification and fitting if necessary.

This appliance is intended to be used in household and similar applications such as:

- Staff kitchen areas in shops, offices and other working environments;
- Farm houses;
- By clients in hotels, motels, and other residential type environments;
- Bed & breakfast type environments.

SAVE THESE INSTRUCTIONS

Congratulations on the purchase of your new Russell Hobbs Desire Matte Black Hand Mixer. Each unit is manufactured to ensure safety and reliability. **Before using the Hand Mixer for the first time, please read this instruction booklet carefully and keep it for future reference.** Pass it on if you pass on the appliance.

When using this appliance, basic safety precautions should always be followed.

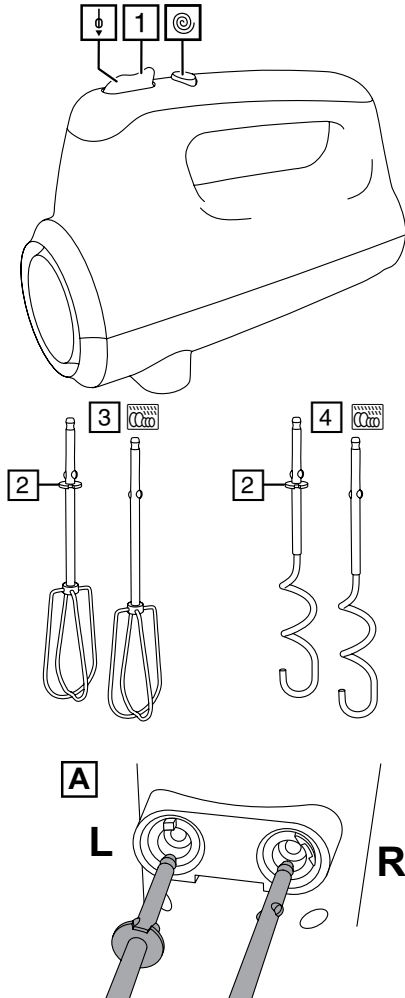

FEATURES

1. Speed control
2. Flange
3. Beaters
4. Hooks

 Dishwasher safe

FITTING THE BEATERS/HOOKS

1. Switch off (0) and unplug the mixer before fitting or removing the beaters/hooks.
2. Turn each whisk or hook to align the pips on the shaft with the slots in the drive head, then push it into the drive head till it clicks into place.
3. Each whisk/hook must be fitted into a specific drive head.
4. Insert the one with the flange into the left-hand drive head (looking up from under the mixer fig. A).
5. Use both beaters or both hooks, don't mix them.

REMOVING THE BEATERS/HOOKS

1. Switch off (0) and unplug the mixer, then shake any excess mixture into the mixing bowl.
2. Hold both beaters/hooks, to prevent them jumping out, and press . This will eject them from the drive heads.

USING THE MIXER

1. Move the speed control to 0.
2. Put the plug into the power socket.
3. Move the speed control to the speed you require (1 to 5).
4. Pressing the turbo button  will over-ride the speed set by the speed control, and give you a burst of high speed. It only works when the motor is already running (1 to 5).
5. Move the speed control to 0 to switch off.
 - Generally, large quantities, thick mixes, and a high ratio of solids to liquids suggest longer timings and slower speeds.
 - Smaller quantities, thinner mixes, and more liquids than solids suggest shorter timings and higher speeds.
 - Use the beaters for beating/aerating light dough and batter.
 - Use the hooks for mixing heavier dough (e.g. bread, fruit-cake).
 - When making dough, use the mixer only for mixing the ingredients. Don't use it for kneading. You'll overload it and damage the motor.
 - Don't run the motor continuously for more than 5 minutes, it may overheat. After 5 minutes switch off for at least 5 minutes, to recover.
 - If the motor starts to labour, add more liquid to the mix, if possible, or switch off and carry on by hand.

CARE AND MAINTENANCE

1. Switch the appliance off (0) and unplug it.
2. Clean the outside surfaces of the appliance with a damp cloth.

 Wash the beaters and hooks in hot soapy water, or in the cutlery basket of your dishwasher.

DISPOSAL/RECYCLING

Legislation in some localities mandates that e-waste (anything with a plug, battery or cord) is disposed of through controlled recycling facilities and must not be disposed of in general household waste. For more information about recycling of electrical and battery operated appliances, please contact your local council or your local household waste disposal service.

Spectrum Brands Australia Pty Ltd

Locked Bag 3004 Braeside
Victoria 3195 Australia

Customer Service in Australia

TollFree: 1800 623 118
Email: info@spectrumbrands.com.au
Website: www.spectrumbrands.com.au

Spectrum Brands New Zealand Ltd

PO Box 9817 Newmarket
Auckland 1149 New Zealand

Customer Service in New Zealand

TollFree: 0800 736 776
Email: service@spectrumbrands.co.nz
Website: www.spectrumbrands.co.nz

Spectrum Brands Australia Pty Ltd and Spectrum Brands New Zealand Ltd Warranty Against Defects

In this warranty:

Australian Consumer Law means the Australian consumer law set out in Schedule 2 to the Competition and Consumer Act 2010;

CGA means the New Zealand Consumer Guarantees Act 1993;

Goods means the product or equipment which was accompanied by this warranty and purchased in Australia or New Zealand, as the case may be;

Manufacturer, We or **us** means:

1. for Goods purchased in Australia, Spectrum Brands Australia Pty Ltd ABN, 78 007 070 573;
or
2. for Goods purchased in New Zealand, Spectrum Brands New Zealand Ltd, as the case may be, contact details as set out at the end of this warranty;

Supplier means the authorised distributor or retailer of the Goods that sold you the Goods in Australia or in New Zealand; and

You means you, the original end-user purchaser of the Goods.

1. Our goods come with guarantees that cannot be excluded under the Australian Consumer Law, or the CGA. You are entitled to a replacement or refund for a major failure and compensation for any other reasonably foreseeable loss or damage. You are also entitled to have the goods repaired or replaced if the goods fail to be of acceptable quality and the failure does not amount to a major failure.
2. The benefits provided by this Warranty are in addition to all other rights and remedies in respect of the Goods which the consumer has under either the Australian Consumer Law or the CGA. The original purchaser of the Goods is provided with the following Warranty subject to the Warranty Conditions:
3. We warrant the Goods for all parts defective in workmanship or materials for a (**Warranty Period**) period of 2 years from the date of purchase.

If the Goods prove defective within the Warranty Period by reason of improper workmanship or material, we may, at our own discretion, repair or replace the Goods without charge.

Warranty Conditions

4. The Goods must be used in accordance with the manufacturer's instructions. This Warranty does not apply should the defect in or failure of the Goods be attributable to misuse, abuse, accident or non-observance of manufacturer's instructions on the part of the user. As far as the law permits, the manufacturer does not accept liability for any direct or consequential loss, damage or other expense caused by or arising out of any failure to use the Goods in accordance with the manufacturer's instructions.
 5. Exhaustible components (such as batteries, filters and brushes) of the Goods are included under this Warranty only where there is a defect in workmanship or materials used.
 6. The warranty granted under clause 3 is limited to repair or replacement only.
 7. Any parts of the Goods replaced during repairs or any product replaced remain the property of the manufacturer. In the event of the Goods being replaced during the Warranty Period, the warranty on the replacement Goods will expire on the same date as for the Warranty Period on the original Goods which are replaced.
 8. In order to claim under the warranty granted under clause 3 you must:
 - (a) Retain this warranty with your receipt/proof of purchase; and
 - (b) Return the Goods to us at the relevant address or to the Supplier by prepaid freight within the Warranty Period accompanied with (i) the legible and unmodified original proof of purchase, which clearly indicates the name and address of the Supplier, the date and place of purchase, the product name or other product serial number and (ii) this warranty.
 9. This warranty is immediately void if:
 - (a) Any serial number or appliance plate is removed or defaced;
 - (b) The Goods have been serviced or otherwise repaired by a person not authorised to do so by us or where non approved replaced parts are used.
 10. The Goods are designed for domestic use only. The Goods must be connected to the electrical voltage requirements as specified in the ratings label located on the Goods.
 11. This warranty does not cover the cost of claiming under the warranty or transport of the Goods to and from the Supplier or us.
 12. This warranty is only valid and enforceable in Australia against Spectrum Brands Australia Pty Ltd and in New Zealand against Spectrum Brands New Zealand Ltd.
- Contact us or the Supplier for further details.

Register your product online

If you live in Australia please visit: www.spectrumbrands.com.au/warranty

If you live in New Zealand Please visit: www.spectrumbrands.co.nz/warranty

Registration of your warranty is not compulsory, it gives us a record of your purchase AND entitles you to receive these benefits: Product information; Hints and tips; Recipes and news; Information on special price offers and promotions.

Any questions? Please contact Customer Service for advice.

NOTES:

A series of horizontal dotted lines for writing notes.

NOTES:

A series of horizontal dotted lines for writing notes.



Russell Hobbs



DESIRE MATTE BLACK HAND MIXER

2 YEAR WARRANTY

RHMX5BLK

RHMX5BLK_IB_RB_FA_030820
Part No. T22-9001946

RECIPE BOOK



WALNUT BREAD STICK

Ingredients:

500g flour
1 sachet dried yeast
1 tbsp walnut oil
1 tsp salt
1¼ cups lukewarm water
90g walnuts, chopped

Method:

1. Preheat oven to 240°C.
2. Sift flour into a bowl with the yeast, make a well in the centre and add walnut oil, salt and water.
3. Using the dough hooks on the Hand Mixer, mix on a low speed until a ball forms, cover lightly with a tea towel and leave to double in size.
4. Knock down dough, knead lightly and work in the nuts. Shape into a baton, place onto an oiled tray and allow to rise for 1 hour.
5. Slash the top of the loaf in a couple of places, dust with flour and bake for approximately 40 minutes.
6. Remove from oven and cool on a wire rack.

www.russellhobbs.com.au

www.russellhobbs.co.nz

RUSSELL HOBBS and logo are Trade Marks of Spectrum Brands, Inc., or one of its subsidiaries.
©2020 Spectrum Brands, Inc.

Recipes are to be used in conjunction with the RHM5BLK Desire Matte Black Hand Mixer by Russell Hobbs. All rights reserved. No part of this publication may be reproduced, stored in a retrieval system or transmitted in any form or by any means, electronic, mechanical, photocopying, recording or otherwise, without prior permission of the copyright owner.

QUICHE LORRAINE

Serves: 4-6

Ingredients:

1 sheet shortcrust pastry
4 thick slices ham, finely diced
1 tbsp butter
1 white onion, finely chopped
3 eggs, well beaten
1½ cup full cream milk
Salt & pepper, to taste
1 tbsp chopped mixed herbs
1½ cups grated cheddar cheese
1 tbsp plain flour

Method:

1. Preheat oven to 160°C. Line a lightly buttered flan or pie dish with the pastry, trim to size.
2. Melt the butter in a small pan, sauté the onion until softened, adding the ham for a minute or two.
3. In a large bowl, beat together the milk and eggs using the beaters on the Hand Mixer at a medium speed. Stir in the salt, pepper, herbs, ham and onion.
4. Toss together the cheese and flour (this helps incorporate the cheese into the milk and egg mixture), then stir into egg mixture, mixing thoroughly.
5. Spoon into the prepared pastry case, ensuring cheese and ham are evenly distributed.
6. Bake for 35 - 45 minutes or until filling has firmed and a knife inserted into the mixture comes out clean. If crust is browning too quickly, cover the edges with some foil.
7. Leave for 10 minutes before serving. Serve at room temperature or allow to cool.

CHOCOLATE AND BANANA PECAN CRUMBLE CAKE

Serves: 8-10

Ingredients:

CRUMBLE MIX

75g light brown sugar

75g pecan halves

100g dark chocolate buttons

CAKE MIX

180g soft light brown sugar

180g low-salt butter

180g small dark chocolate buttons

2 large very ripe bananas, mashed

2 large eggs, beaten

250g self-raising flour, sifted

Method:

1. Preheat oven to 170°C. Combine all the crumble mix ingredients in a food processor and pulse until coarse crumbs are formed.
2. Melt together butter, sugar and chocolate over simmering water. Set aside to cool.
3. In a small bowl, beat eggs with the Hand Mixer and beaters on a high speed. Add mashed bananas and beat together.
4. Stir the eggs and bananas in the cool melted ingredients, mixing thoroughly.
5. Sift in the flour, mixing in lightly but thoroughly.
6. Spoon half the cake mixture into a buttered, loose based 24cm spring form tin. Sprinkle half the crumble mixture evenly over the surface, spoon on the remaining cake mixture and spread gently and evenly. Sprinkle on the rest of the crumble mix.
7. Bake for 40 minutes or until just firm to the touch and place on a wire rack.
8. Leave until cool, and then loosen the tin.
9. Serve cold for afternoon tea or warm as a dessert.

NUT CHOC CHIP BISCUITS

Makes: 24

Ingredients:

- 125g butter, softened
- 1 cup brown sugar
- 1 egg, lightly beaten
- 1½ cup self-raising flour
- ½ cup choc chips
- 1 cup mixed nuts, chopped

Method:

1. Preheat oven to 170°C. Lightly grease a baking tray.
2. Chop the butter and place into a bowl with the sugar.
3. Starting at a slow speed, use Hand Mixer with beaters to beat together the butter and sugar until mixture is soft and creamy.
4. Stir in the beaten egg, and then gradually add the flour, choc chips and nuts. Mix thoroughly with a wooden spoon until combined.
5. Place 1 tablespoon-sized balls of mixture on the baking tray (allow some space for spreading) and bake in the oven for 15-20 minutes or until nicely browned.
6. Allow to cool for 5 minutes on the tray. Transfer onto wire racks to cool completely before storing in an airtight container.

CUPCAKES

Makes: 12

Ingredients:

125g butter, softened

1 cup castor sugar

3 eggs

1½ cups plain flour

1 tsp baking powder

¾ cup milk

1 tsp vanilla essence

Method:

1. Preheat oven to 180°C. Place cupcake papers into a muffin tin.
2. In a bowl, combine butter and half the sugar. Using Hand Mixer with beaters, beat until mixture becomes creamy. Add remainder of sugar and continue beating. Add eggs one at a time, beating well after each addition.
3. Sift together flour and baking powder. Add to the creamed mixture with the milk and vanilla, stirring well until combined.
4. Spoon mixture into paper cups approx ¾ full. Bake for 20-25 minutes or until the top springs back when lightly touched.
5. Allow to cool, then top with your favourite frosting and decorations.

BRAZILIAN SPICED HOT CHOCOLATE

Serves: 6

Ingredients:

- 1½ litres full cream milk
- 5 cinnamon sticks
- 8 cloves
- 1/3 cup castor sugar
- 125g dark chocolate, broken into pieces
- 1 tsp vanilla essence

MERINGUE TOPPING:

- 2 egg whites
- ½ cup sugar

Method:

1. Pour the milk into a saucepan. Add the cinnamon and cloves and simmer gently for 8 minutes without allowing the milk to come to a full boil.
2. Strain about 500mL of the hot milk into a blender and add the broken chocolate. Start on low speed and then increase to high speed as the chocolate melts.
3. Blend thoroughly and return to the saucepan with the remaining milk and sugar.
4. Simmer whilst stirring constantly until chocolate has completely dissolved and mixture has thickened slightly. Add vanilla and stir thoroughly.
5. To make the meringue, using the Hand Mixer with beaters, beat the egg whites to a stiff consistency and gradually beat in the sugar. The meringue should be very stiff.
6. To serve, pour the chocolate milk into small cups, place a scoop of meringue on top and sprinkle with dark chocolate.