

SENCOR®

SRV 8250BK



EN ■ Robotic Vacuum Cleaner

Translation of the original manual

READ CAREFULLY AND STORE FOR FUTURE USE.**General warnings**

- This appliance may be used by children 8 years of age and older and by persons with physical or mental impairments or by inexperienced persons, if they are properly supervised or have been informed about how to use the product in a safe manner and understand the potential dangers.
- Children must not play with the appliance. Cleaning and maintenance performed by the user must not be performed by unsupervised children.
- In the event that the power cord is damaged, have it repaired at a professional service centre to prevent causing a dangerous situation. It is forbidden to use the appliance if it has a damaged power cord.
- The robotic vacuum cleaner must only be used with the original power adapter that came with it. In order to avoid a dangerous situation from arising, never use a different type of power adapter.
- Prior to cleaning or maintenance, always disconnect the robotic vacuum cleaner from the power socket and turn it off using the power button.
- Adhere to the instructions contained in this user's manual when performing cleaning and maintenance tasks.
- For charging the robotic vacuum cleaner, only use the original charging station that was supplied with it.
- The appliance must only be powered using a small safe voltage corresponding to the markings on the appliance.

Electrical safety

- Before connecting the adapter to a power socket check that the technical details on the rating label match the electrical voltage in the socket.
- Connect the power adapter only to a properly grounded power socket. Do not use an extension cord.
- Do not disconnect the power adapter from the power socket by pulling on the power cord. This could damage the power adapter or the power socket. Disconnect the power adapter from the power socket by pulling on the plug.
- Do not place the power cord of the power adapter over sharp objects. Make sure that the power cord does not hang over the edge of a table and that it is not touching a heated or hot surface.
- It is forbidden to use a power adapter with a damaged plug or power cord.
For a replacement power adapter, please contact an authorised service centre.
- Never use the power adapter supplied with this appliance for any other purposes.
- Keep the power adapter and its power cord dry.
- If the power cord of the power adapter is damaged, it must be replaced by the manufacturer, its service technician or by a similarly qualified person, as this will prevent a dangerous situation from arising.
- Do not connect and disconnect the power adapter cord to and from the power socket with wet hands.
- Do not uncover the electronic parts of the robotic vacuum cleaner or its battery. They do not contain any components repairable by the user. Have the appliance serviced by qualified persons.
- To charge the battery, only use the power adapter supplied with this robotic vacuum cleaner.
- To avoid any injury by electrical shock, do not spray the robotic vacuum cleaner with water and do not submerge it in water or any other liquid.
- If you will not be using the robotic vacuum cleaner for an extended period of time, take out the battery. Prior to taking out the battery, ensure that the robotic vacuum cleaner is disconnected from the power socket and that it is turned off using the main switch.
- Do not use the robotic vacuum cleaner when it is not working correctly, if it has been damaged or has been submerged in water.
- To avoid the danger of injury by electrical shock, do not repair the robotic vacuum cleaner yourself or make any adjustments to it. Have all repairs performed at an authorised service centre. Tampering with the robotic vacuum cleaner during the warranty period may void the warranty.
- Prior to cleaning or maintenance, always disconnect the robotic vacuum cleaner from the power socket and turn it off using the main switch.

Safety during use

- This robotic vacuum cleaner is designed for use in households, offices and similar types of areas. Do not use it in industrial surroundings or outdoors.
- The robotic vacuum cleaner is not intended for vacuuming water and therefore must not be used in damp or wet areas, for example in laundries, bathrooms or around swimming pools. If it were to come into contact with water, the internal electronics of the vacuum cleaner would be destroyed.
- Do not use the robotic vacuum cleaner to vacuum the following items:
 - smouldering cigarettes, burning or flammable items, matches or ash;
 - water and other liquids;
 - sharp items, e.g. splinters, needles, pins, etc.;
 - flour, wall plaster and other building materials;
 - larger pieces of paper or plastic bags, which can easily block the suction hole.
- Do not expose the robotic vacuum cleaner to direct sunlight and do not place it near an open fire or appliances that are a source of heat.
- Do not use the robotic vacuum cleaner on narrow raised surfaces such as tables, wardrobes, etc. If the vacuum cleaner does not have sufficient space for manoeuvring, it may fall and be damaged.
- Only use the robotic vacuum cleaner with the original accessories from the manufacturer.
- Ensure that the robotic vacuum cleaner has a dust filter correctly installed in the dust container before use.
- Before putting the robotic vacuum cleaner into operation, check that the entry door into your apartment or house is closed. From the floor surfaces, remove clothing, paper, toys, power or extension cords and other items that the vacuum cleaner could suck in or catch. Lift curtains and drapes that reach to the floor so that they do not get caught in the vacuum cleaner.
- Do not place any items on to the robotic vacuum cleaner and do not step or sit on it.
- If the robotic vacuum cleaner is running, watch out for children and household pets.
- When the robotic vacuum cleaner is running, ensure that the air vents are not covered and that the suction hole is not blocked. Otherwise, the robotic vacuum cleaner may be damaged.

A

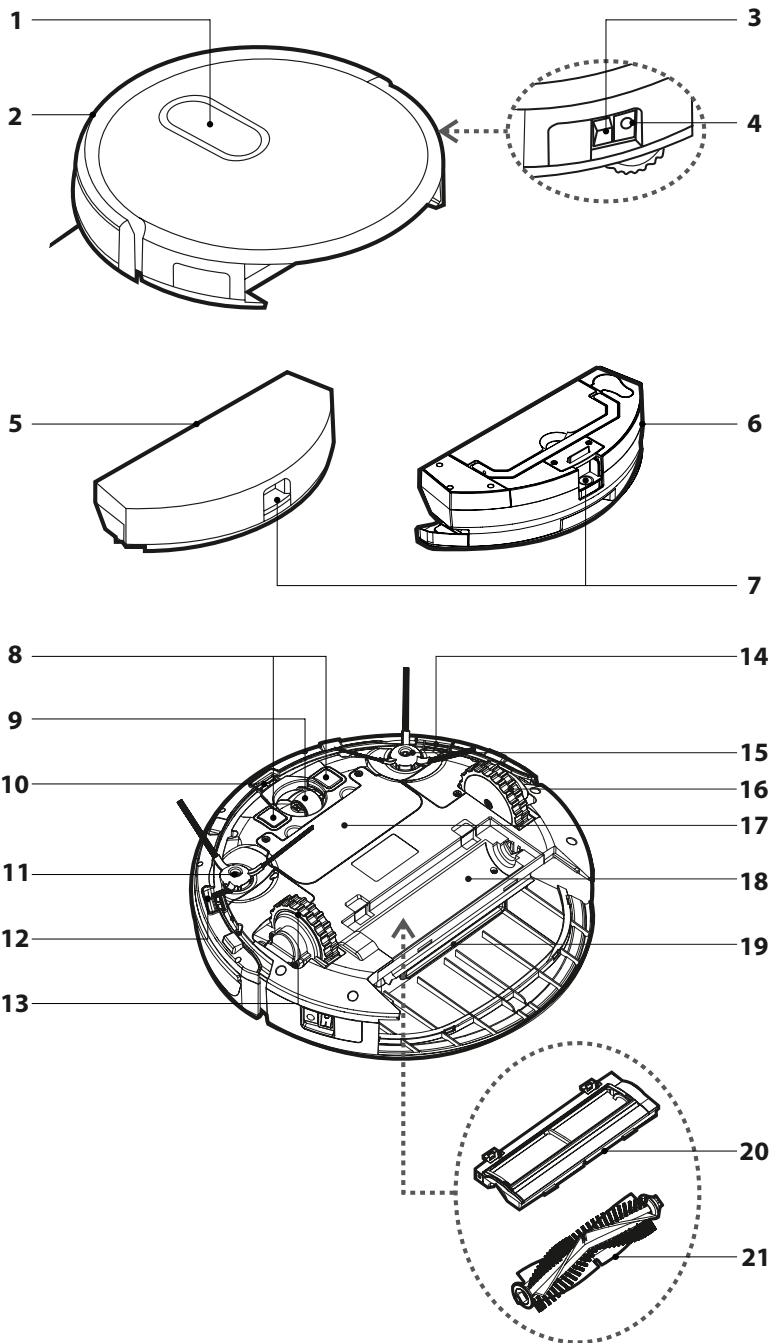

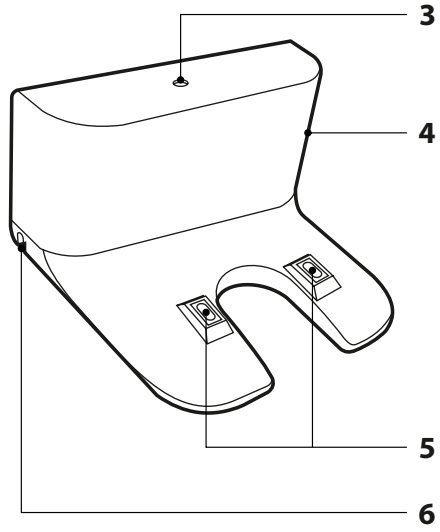
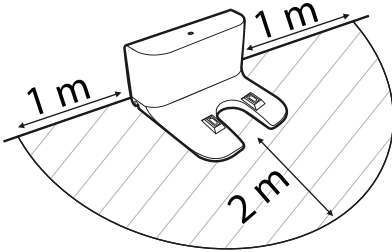
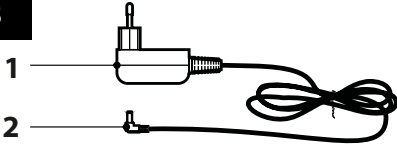
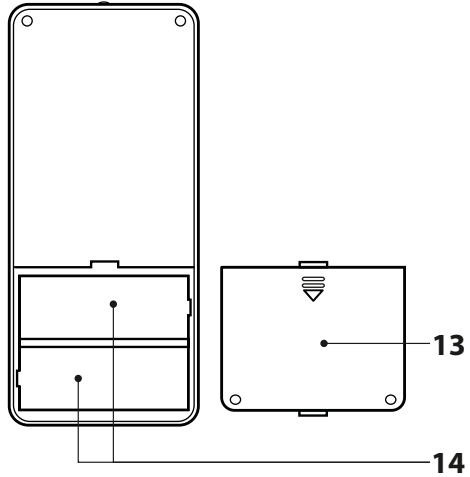
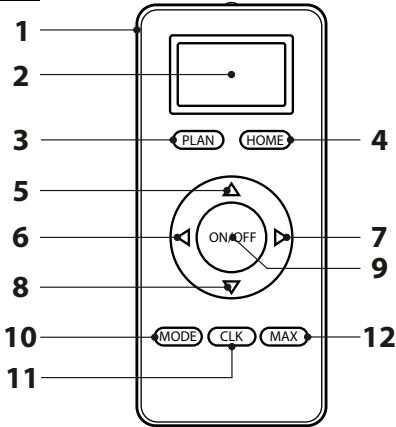
B**C**

D

1

2

3

4

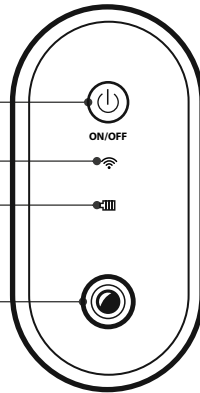

E

1

2

3

4

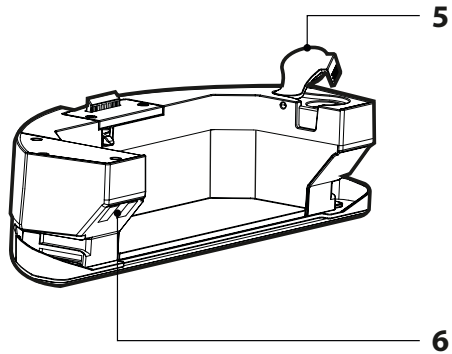
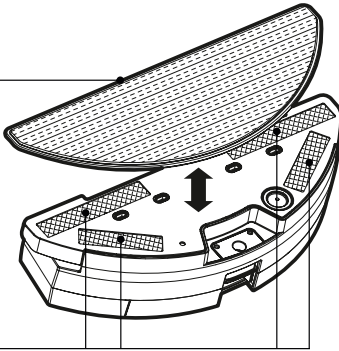
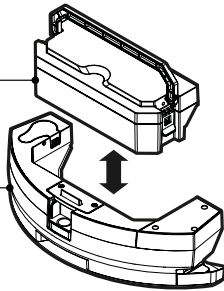

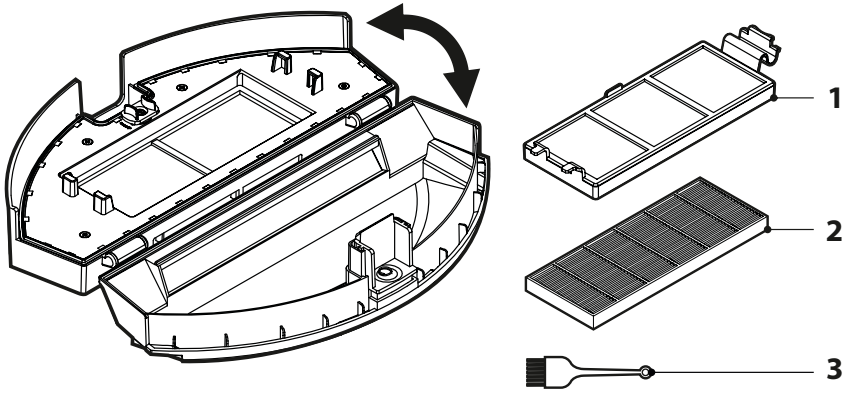
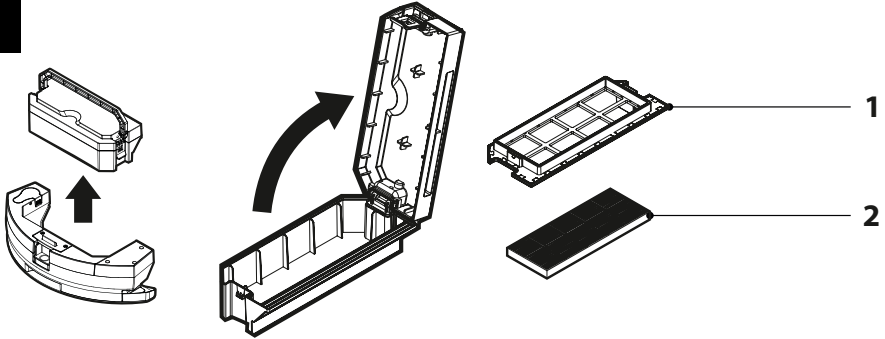
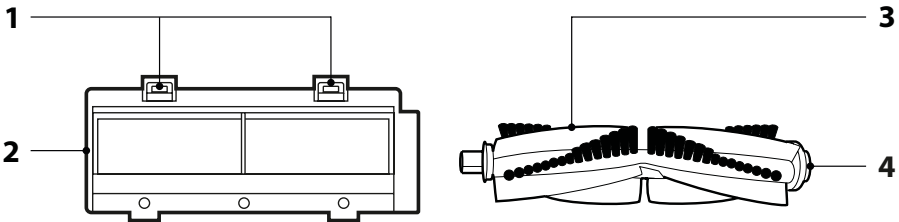
F**G****H**

1

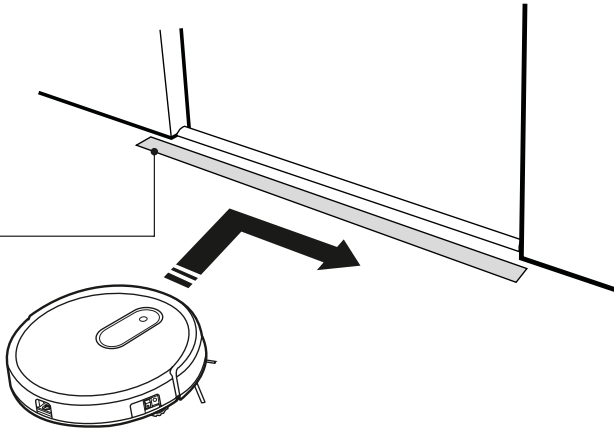

EN: Link to the application for controlling the vacuum cleaner

APP Store



Google Play



BEFORE FIRST USE

- Prior to using this appliance, please read the user's manual thoroughly, even in cases, when one has already familiarised themselves with previous use of similar types of appliances. Only use the appliance in the manner described in this user's manual. Keep this user's manual in a safe place where it can be easily retrieved for future use. In the event that you hand this appliance over to somebody else, make sure to also include this user's manual.
- We recommend saving the original cardboard box, packaging material, purchase receipt and responsibility statement of the vendor or warranty card for at least the duration of the legal liability for unsatisfactory performance or quality. In the event of transportation, we recommend that you pack the appliance in the original box from the manufacturer.
- Carefully unpack the appliance and take care not to throw away any part of the packaging before you find all the parts of the appliance.

DESCRIPTION OF THE APPLIANCE AND ACCESSORIES

A1 Control panel	A10 Bottom anti-fall sensor, central
A2 Bumper bar with an anti-collision sensor	A11 Left rotary brush (L)
A3 Main switch	A12 Bottom anti-fall sensor, left
A4 Power adapter connector socket	A13 Left motorised rubber wheel
A5 Dust container	A14 Bottom anti-fall sensor, right
A6 2-in-1 mop unit	A15 Right rotary brush (R)
Consists of a water tank, dust container and a mop fabric	A16 Right motorised rubber wheel
A7 Container release latch	A17 Battery compartment cover
A8 Charging contacts	A18 Central rotary brush compartment
A9 Front swivel wheel	A19 Suction hole
A20 Central rotary brush cover	A21 Central rotary brush
B1 Power adapter	B4 Charging station
B2 Power adapter plug	B5 Charging contacts
B3 Power indicator	B6 Power adapter plug socket
C1 Remote control	C9 Vacuum cleaner start / off button
C2 Display	C10 Cleaning mode selection button
C3 Scheduled cleaning setting mode	C11 Time setting button
C4 Return to the charging station button	C12 Maximum cleaning mode in which the vacuum cleaner cleans until the battery is almost flat.
C5 Forward button	C13 Battery compartment cover
C6 Left button	C14 Battery compartment (2pcs AAA x 1.5V)
C7 Right button	D3 Battery power indicator
C8 Reverse button	D4 360° panoramic camera
D1 Power button	E4 Duster fastening velcro strips
D2 Wi-Fi indicator	E5 Filling opening cap
E1 Dust container	E6 Container contacts
E2 Water tank	
E3 Mop fabric	
F1 HEPA filter holder	filter able to capture even the finest dust particles.
F2 HEPA filter	
Highly effective air-borne particle	F3 Cleaning brush
G1 HEPA filter holder	filter able to capture even the finest dust particles.
G2 HEPA filter	
Highly effective air-borne particle	
H1 Latches	H3 Rotary brush
H2 Rotary brush cover	H4 Brush bearings
I1 Magnetic tape	

PURPOSE OF USE AND FEATURES OF THE ROBOTIC VACUUM CLEANER

- The robotic vacuum cleaner is intended for cleaning various types of hard floors such as wooden or laminate floating floors, tiles, vinyl, etc. and carpets with a low pile height. While vacuuming, it effectively combines various routes to optimally clean the entire floor area.
- The suction hole effectively removes hair, animal fur, etc. The two side rotary brushes brush dirt out of hard-to-reach places along walls and furniture and out of corners. The motorised rubber wheels protect sensitive floors against scratching and can travel over threshold strips up to a height of 1 cm and ride on to a 2 cm high carpet.
- The suspended bumper enables the vacuum cleaner to dampen the approach to an obstacle and to efficiently clean around it. The infrared sensors in the front bumper prevent the robotic vacuum cleaner from colliding with obstacles. Safe operation in rooms with stairs is made possible by the bottom anti-stair-fall sensors.
- Another advantage of a robotic vacuum cleaner is the mop function, which enables dry and wet wiping of smooth hard floor surfaces. While wiping, the vacuum cleaner vacuums small bits of dirt and dust from the floor to prevent the mop fabric from being excessively soiled during the cleaning cycle. When the vacuum cleaner finishes cleaning, it will automatically shut off the supply of water and thereby limit

it leaking on to the floor.

- For easy identification of the operating state, the button on the cover has an indicator light the colour of which indicates low battery voltage (lit red), battery charging (flashing alternately red and blue), full charge and operation (lit blue). Apart from the indicator lights, the vacuum cleaner also has audio signals and voice messages that accompany certain functions or error states of the vacuum cleaner, see chapter VOICE MESSAGES.
- The remote control facilitates convenient control, enabling the vacuum cleaner to be turned on and off, to be set to the automatic cleaning mode, to select an operating mode, to send the robotic vacuum cleaner to the charging station or to set scheduled cleaning.
- The vacuum cleaner is equipped with a GYRO MAPPING function (orientation in space) and a 360° panoramic camera with the help of which it is able to identify the spatial geometry the room that it is cleaning. The vacuum cleaner thereby misses no spots and cleans the floor more effectively. This is a built-in function and cannot be affected in any way.

PREPARING THE ROBOTIC VACUUM CLEANER FOR OPERATION INSTALLING AND USING THE ROTARY BRUSHES

- The rotary brushes **A11** and **A15** are intended for smooth floor surfaces and ensure effective cleaning in corners, along walls and furniture.
- Turn the vacuum cleaner upside down. Gradually push the rotary brushes precisely and with force on to the pins that are intended for them. While doing this, make sure that the marks **L** and **R** both on the brushes and on the vacuum cleaner match. Turn the vacuum cleaner back over to the operating position.
- When using the vacuum cleaner to clean rooms with carpets, remove the rotary brushes. When removing them, proceed in the reverse sequence to their installation.

INSERTING AND REMOVING THE BATTERY

- The robotic vacuum cleaner is equipped with a Li-ion battery. If the battery is packed separately, it is necessary insert it into the vacuum cleaner before first use. Use only the original battery type.
- Make sure that the vacuum cleaner is turned off with the main switch **A3**. Turn the vacuum cleaner upside down and screw off the cover **A17**.
- Remove the vacuum cleaner connector from the battery compartment. Connect the battery connector to it. The battery can only be connected in one direction.
- Screw the cover **A17** back on and turn the vacuum cleaner back over to the operating position.
- Remove the battery in reverse sequence. Prior to removing it, always check that the vacuum cleaner is turned off using the main switch. The fabric strips on the body of the battery make battery removal easier.
- When the vacuum cleaner will not be used for an extended period of time, take out the battery and store it in a dry, clean and cool place out of children's reach.

LOCATION OF THE CHARGING STATION

- The charging station **B4** serves to automatically recharge the battery and the vacuum cleaner must have good access to it.
- Locate the charging station against a wall on a hard, even and dry surface within reach of a power socket. Make sure that there are no stairs or obstacles within a distance of 1 m on the left and right of the charging station and within a distance of 2 m in front of the charging station, that would prevent the vacuum cleaner from finding the charging station and docking successfully.
- Insert the power adapter plug **B2** into socket **B6** of the charging station, and insert the power cord plug into a power socket. Place the power cord in such a way that it does not tangle into the cleaning brushes of the vacuum cleaner.
- In the event that the vacuum cleaner is not used for an extended period of time, disconnect the charging station from the power socket and store it in a dry, clean and cool place.

CHARGING THE BATTERY FOR THE FIRST TIME



Note:

Prior to charging the battery, the vacuum cleaner must be turned on using the main switch **A3**.

- Before using the vacuum cleaner for the first time, it is necessary to fully charge the battery for at least 5 hours.
- Check that the charging station is correctly positioned and connected to a power socket according to chapter Location of the charging station. Turn on the main switch **A3** of the vacuum cleaner, grasp the robotic vacuum cleaner and manually place it into the charging station so that the charging contacts **A16** on the underside of the vacuum cleaner and the charging contacts **B5** on the charging station are connected. When the contacts are connected, the charging process will start.
- The vacuum cleaner can also be charged without using the charging station. Insert the plug **B2** of the power adapter **B1** into socket **A4** of the vacuum cleaner, and insert the power cord plug into a power socket.
- During the charging process, the indicator light on button **D1** will alternately flash blue and red.
- When the battery is fully charged, the indicator light of button **D1** will remain permanently lit blue and the process will end automatically. The vacuum cleaner is now ready for use.

INSERTING AND REPLACING BATTERIES IN THE REMOTE CONTROL

- Push down the latch of cover **C13** on the rear side of the remote control **C1** to release it and remove the cover.
- Insert two type AAA (1.5 V) batteries into the remote control. When inserting the batteries, ensure the correct polarity as shown inside the battery compartment **C14**. Put the cover **C13** back on and click it into place.
- In the event that the batteries are flat, replace them with new ones. Do not combine various types of batteries or new and old batteries.
- The signal range of the remote control is approximately 6 m.

SETTING SYSTEM TIME ON THE REMOTE CONTROL

- The system time of the vacuum cleaner is the actual time according to your time zone. It must be correctly set if you wish to use the scheduled cleaning function.
- In the stand-by mode or in the charging in the charging station mode, hold down button **C11** (CLK) until the time setting value (hours and minutes) starts flashing on the display **C2**.
- Using buttons **C5** (Δ) or **C8** (∇) set the time values. Toggle between the hour and minute numbers using buttons **E6** (\triangleleft) or **C7** (\triangleright).
- Confirm the set time by pressing button **C11** (CLK). The appliance will beep 1x and the set time will be saved to the memory of the remote control as the system time.
- If you do not perform any changes within 10 seconds, the system time setting mode will automatically be cancelled and the time will not be saved to memory.

DEFINING THE VACUUMING AREA USING MAGNETIC TAPE

- The magnetic tape **I1** serves to define the vacuuming area without you having to close doors or place artificial obstacles in the path of the vacuum cleaner. The vacuum cleaner will recognise the magnetic tape and will not travel over it. It will start cleaning in another direction.
- Place the magnetic tape before the place that the robotic vacuum cleaner should not clean, for example room doorway, carpet, cables on the floor or a staircase with rounded corners, etc.
- To help the magnetic tape adhere better, you can attach it to the perimeter using standard double-sided tape. It can also be cut into smaller pieces as required. Additional tape can be purchased to extend the defined area.



Note:

The magnetic tape must be put down prior to every cleaning session because the robotic vacuum cleaner does not store the boundaries in memory.

OPERATING THE ROBOTIC VACUUM CLEANER



Note:

Before starting the vacuum cleaner, always make sure that either the dust container **A5** or the complete mop unit **A6** including the respective HEPA dust filters is inserted inside.

TURNING ON THE ROBOTIC VACUUM CLEANER

- Turn on the power supply to the vacuum cleaner using the main switch **A3**.
- Press button **D1**. The button's indicator will start flashing blue. When the indicator is permanently lit blue, the vacuum cleaner is in stand-by mode and ready for operation.

STAND-BY MODE

- The stand-by mode means that the vacuum cleaner is ready for operation. Button **D1** is backlit in blue colour.
- Set the vacuum cleaner to the stand-by mode by pressing button **D1** on the vacuum cleaner or buttons **C9** (ON/OFF) on the remote control either by turning on the power supply using main switch or whenever while the vacuum cleaner is running.

SLEEP MODE

- The sleep mode serves to save the battery's capacity. The vacuum cleaner enters sleep mode either automatically after ten minutes of inactivity or when it is unable to dock in the charging station. The backlight on button **D1** will turn off and the vacuum cleaner will automatically switch to the sleep mode.
- To wake the vacuum cleaner from the sleep mode to the stand-by mode, press button **D1** on the vacuum cleaner or the control button **C9** (ON/OFF) on the remote control.



Note:

When the vacuum cleaner is in sleep mode, it is not possible to wake it up using the mobile phone application. In sleep mode, it reacts only to buttons **D1** or **C9** (ON/OFF) on the remote control.

TURNING VOICE MESSAGES ON/OFF

- If you prefer not to have the vacuum cleaner make system voice messages, deactivate this function by simultaneously pressing buttons **C3** (PLAN) and **C4** (HOME) on the remote control. The vacuum cleaner will only make beeps.
- If you wish to reactivate the voice messages, again simultaneously press the buttons **C3** (PLAN) and **C4** (HOME).

TURNING OFF THE ROBOTIC VACUUM CLEANER

- If you wish to completely turn off the vacuum cleaner, set the main switch **A3** to position **0** (off). The backlight on button **D1** will turn off and the power supply will be shut off. When the vacuum cleaner is turned off, it will not respond to any button.

SELECTING THE ROBOTIC VACUUM CLEANER CLEANING MODE

- Before starting the cleaning process, check that the entry door into your apartment or house is closed. From the floor surfaces, remove clothing, paper, toys, power or extension cords and other items that the vacuum cleaner could suck in or catch. Lift curtains and drapes that reach to the floor so that the vacuum cleaner does not catch them.



Tip:

When vacuuming in a new environment for the first time, carefully observe the movement of the vacuum cleaner. You can thereby recognise problematic obstacles and remove them for the next cleaning session.

AUTOMATIC CLEANING MODE

- Press button **D1** or button **C9** (ON/OFF) on the remote control. The vacuum cleaner will enter the automatic cleaning mode, in which it effectively combines various routes to achieve an optimal clean of the entire floor area. As soon as the vacuum cleaner finishes cleaning, it will seek out the charging station and dock there to recharge.

MAXIMUM POWER MODE

- Press button **C12** (MAX) on the remote control. The vacuum cleaner will enter the cleaning mode, in which it effectively combines various routes to achieve an optimal clean of the entire floor area. This mode is characterised by increased motor and central rotary brush power for the purpose of achieving the most effective cleaning process.

ALONG-THE-WALLS CLEANING MODE

- Repeatedly press button **C10** (MODE) on the remote control so that display **C2** shows **MODE1**. The vacuum cleaner will enter the along-the-walls cleaning mode, in which it moves along the perimeter of the room and the motorised side rotary brushes sweep out the dirt along the walls, furniture corners to achieve a perfect clean. As soon as the vacuum cleaner finishes cleaning, it will seek out the charging station and dock there to recharge.

2x2 METRE AREA (SPOT) CLEANING MODE

- Place the vacuum cleaner approximately in the middle of the area that you wish to clean.
- Repeatedly press button **C10** (MODE) on the remote control so that display **C2** shows **MODE2**. The vacuum cleaner will enter the cleaning mode in which it will move in straight parallel lines and vacuum an area of approximately 2 x 2 metres. As soon as the vacuum cleaner finishes cleaning this area, it will seek out the charging station and dock there to recharge.

RANDOM DIRECTION MOVEMENT MODE

- Repeatedly press button **C10** (MODE) on the remote control so that display **E2** shows **MODE3**. The vacuum cleaner will enter the random direction movement mode and will continue cleaning in this mode until the battery is almost flat. It will then end the cleaning process and seek out the charging station in order to recharge itself.

INTENSIVE CLEANING MODE

- Repeatedly press button **C10** (MODE) on the remote control so that display **E2** shows **MODE4**. The vacuum cleaner will enter the intensive cleaning mode, where it will clean the same location twice. It will then end the cleaning process and seek out the charging station in order to recharge itself.

PAUSING THE CLEANING PROCESS

- Press button **D1** or **C9** (ON/OFF) on the remote control at any time during the cleaning process to stop the vacuum cleaner in the place where it is cleaning.

USING THE MOP UNIT

- The mop unit is used for simultaneous vacuuming and dry or wet wiping of smooth floor surfaces. It consists of the removable dust container **E1**, water tank **E2** and the mop fabric **E3**. The water tank is equipped with an electronically-controlled water pump that automatically doses the water on to the fabric and also stops dosing water at the end of the cleaning process to prevent water from leaking on to the floor or the charging station.



Attention:

Only use the mop unit intended for this type of robotic vacuum cleaner.

Do not use the water tank **E2** without the mop fabric attached. The mop unit is not intended for cleaning carpets.

Dry wiping of floors

- Dry wiping is used for removing fine dust and floor polishing.
- If the mop unit is inserted inside the vacuum cleaner, press latch **A7** and slide the unit out of the vacuum cleaner.
- Attach the mop fabric to the underside of the water tank using the velcro zip **E4** on the water tank and insert the unit back into the vacuum cleaner.
- Start the vacuum cleaner.

Wet wiping of floors

- Wet wiping is used for cleaning away minor dirt and floor polishing
- If the mop unit is inserted inside the vacuum cleaner, press latch **A7** and slide the unit out of the vacuum cleaner.

- Slide the dust container out of the water tank.
- Attach the mop fabric to the underside of the water tank using the velcro zip **E4** on the water tank.
- Open the cap **E5** and fill the tank with water. Properly insert the cap back in. Wipe any excess water off the water tank. Take special care to ensure that the contacts **E6** are dry.



Note:

For wiping, we recommend using clean water. If you use a cleaning agent, it may foam up and thereby worsen the dripping of the water on to the fabric, or potentially cause smudges on the floor after it dries.

- Insert the dust container back into the water tank and insert this assembly back into the vacuum cleaner.
- Start the vacuum cleaner.

SCHEDULED CLEANING



Note:

The scheduled cleaning time setting is based on the system time set on the remote control. Therefore, before setting the scheduled cleaning time, it is necessary to correctly set the system time as described in chapter SETTING SYSTEM TIME ON THE REMOTE CONTROL.

- This function enables scheduling the vacuum cleaner to automatically start cleaning at a certain time once per day. If you use the application, it is possible to schedule a cleaning time for every day at a different time. Please follow the instructions in the application.
- This function behaves as a delayed start, so you are actually setting a delayed cleaning time. Example: If the current time on the vacuum cleaner is 5:00 p.m. then by setting the scheduled cleaning time to 2:30 the vacuum cleaner will automatically start cleaning only at 7:30 p.m. If you leave the main switch of the vacuum cleaner turned on, then the same cleaning process will be repeated at 7:30 p.m. every day thereafter.



Attention:

Never use the delayed cleaning function for wet wiping when the water tank is filled with water. This could result in excessive wetting of the floor in the vicinity of the charging station.

Setting scheduled cleaning:

- In the stand-by mode or in the charging in the charging station mode, hold down button **C3** (PLAN) until the time setting value starts flashing on the display **C2**.
- Using buttons **C5** (▲) or **C8** (▼) set the time values. Toggle between the values using buttons **C6** (◀) or **C7** (▶).
- Confirm the set time by pressing button **C9** (ON/OFF). When confirming, the remote control must be pointed at the vacuum cleaner. The vacuum cleaner will confirm the scheduling via a voice message SCHEDULING CONFIRMED.

Cancelling scheduled cleaning using the remote control:

- Following the procedure described in the paragraph above, set the time value on the display to 00:00 and confirm the value by pressing button **C9** (ON/OFF). When confirming, the remote control must be pointed at the vacuum cleaner. The vacuum cleaner will confirm the scheduling via a voice message NO SCHEDULING.
- The scheduled cleaning can also be cancelled via the smartphone application.

CONTROLLING THE ROBOTIC VACUUM CLEANER USING THE MOBILE APPLICATION

- The vacuum cleaner can also be controlled using a smartphone or tablet. The application enables the one to select the cleaning mode, pause cleaning as well as return to the charging station, schedule cleaning for a selected time that may differ for the individual days of the week, furthermore, cancel scheduled cleaning and also provides an overview of the cleaning time and the status of the robotic vacuum cleaner.
- The application is freely available in the **Apple App Store** or **Google Play Store**. This link for this application is found in the picture part of this user's manual.



Note:

The robotic vacuum cleaner supports Wi-Fi in the 2.4 and 5 GHz frequency band. If unsure about which standards are used by your Wi-Fi network and your router, please contact your internet service provider or the manufacturer of the router.

- After downloading and installing it, the application will guide you through the process for connecting the robotic vacuum cleaner to your Wi-Fi network. Turn off mobile data on your smartphone before connecting to the Wi-Fi network.

CHARGING THE ROBOTIC VACUUM CLEANER AUTOMATIC CHARGING

- As soon as the vacuum cleaner detects low voltage of the battery during operation, it will automatically start to seek out the charging station. In order for it to find it and dock, it needs to find the infrared signal transmitted by the charging station. For this reason, we recommend leaving the charging station constantly connected to the power source and located in accordance with the instructions provided in chapter LOCATION OF THE CHARGING STATION.

- After docking in the charging station, the charging cycle will commence. A complete charge takes approximately 4 to 7 hours. The actual charging time depends on the power level of the battery. A fully charged battery will provide up to 120 minutes of operation.
- During the charging process, the indicator light on button **D1** will alternately flash red and blue.
- When the battery is fully charged, the indicator light of button **D1** will remain permanently lit blue and the process will end automatically.
- In the event that the charging contacts are disconnected during the charging cycle, the vacuum cleaner will move away from the charging station and then re-dock itself to resume the charging process, unless it is prevented from doing so by an obstacle. In the event of a power outage, the charging cycle will be interrupted and will continue after the power supply is renewed. In the event that the maximum charging current is exceeded, the charging station will automatically interrupt the charging cycle.

MANUAL CHARGING

- If the vacuum cleaner is located away from the charging station and detects a low battery voltage then button **D1** will be lit red. Press button **C4** (HOME) on the remote control. The vacuum cleaner will automatically seek out the charging station and start automatic charging as described in the previous chapter.
- If the battery is so flat that the vacuum cleaner is unable to seek out the charging station then it is necessary to dock the vacuum cleaner into the charging station by hand. Grasp the vacuum cleaner and manually place it into the charging station so that the charging contacts on the underside of the vacuum cleaner and the charging contacts on the charging station are connected. When the contacts are connected, charging will start.
- The vacuum cleaner can also be charged without using the charging station. Insert the power adapter connector into socket **A4** on the side of the vacuum cleaner and insert the power adapter plug into a mains socket.

CARING FOR THE BATTERY

- We recommend that you do not interrupt the charging cycle and maintain the battery in a charged state.
- Do not leave the vacuum cleaner standing fully charged or completely flat for an unnecessarily long period of time.
- A battery that is allowed to remain flat for a long time may self-discharge below a permissible level and thereby cause irreparable damage to itself.

TROUBLESHOOTING

PROBLEM	POSSIBLE CAUSE	SOLUTION
The vacuum cleaner cannot be turned on.	The battery is not inserted correctly in the robotic vacuum cleaner.	Insert the battery according to the instructions in this user's manual.
	The battery is flat.	Charge the battery.
The vacuum cleaner is on, but it is not vacuuming dust and dirt.	The dust container is full.	Empty the dust container.
	The dust filter is not properly installed in the dust container.	Properly install the dust filter into the dust container.
The vacuum cleaner travels only backwards when it is turned on.	The vacuum cleaner was placed on a floor that is too dark.	Move the vacuum cleaner to a lighter-coloured floor and start it again.
	An anti-fall sensor is dirty.	Clean the anti-fall sensors.
The rotary brushes are deformed and do not sweep up dust and dirt.	The brushes are worn out.	Dip them in warm water to renew their original shape.
		Contact the vendor or service centre and order new brushes.

VOICE MESSAGES

MESSAGE	SOLUTION
Please turn on the power switch	Turn on the vacuum cleaner
Please charge	Dock the robot into the charging station.
Please put the machine in a safe place	If the vacuum cleaner was lifted, put it down on the floor
	Anti-fall sensors are dirty. Clean them.
	Sensor sent a false error. Turn the vacuum cleaner off and on.
Left front bumper fault	Check that the bumper bar returns correctly after being pushed in. If not, contact the service department.
Wheel overload	Overload of one of the rubber wheels, probably due to dirty material or jamming on an obstacle. Check that the wheels are clean and remove any dirty material or obstacles.

Side brush overload	Overload of one of the side rotary brushes, probably due to dirty material or jamming on an obstacle. Clean the rotary brush according to the instructions in this user's manual. Remove any obstacles.
Rolling brush overload	Overload of the central rotary brush, probably due to dirty material. Clean the rotary brush according to the instructions in this user's manual.

CLEANING AND MAINTENANCE

- Prior to cleaning it, always turn off the vacuum cleaner using the main switch **A3**.
- For cleaning, never use abrasive cleaning products, solvents, etc.
- Neglecting cleaning and maintenance may negatively affect the working order of the vacuum cleaner and lead to its reduced performance.

DUST CONTAINER AND DUST FILTER

- Empty out the dust container **A5** after every use and clean it regularly. Press latch **A7** to slide the dust container out of the vacuum cleaner, open it and tip out the dirty material. For hygiene reasons, we recommend doing this away from living areas.
- Release the filter holder **F1** and the dust filter **F2** and take them out of the water tank.
- Wash both parts of the dust container under running water and dry it well.



Note:

The inside of the dust container does not need to be washed after every use, it is sufficient to wipe it out with a wet wiping cloth.

- Tap out the dust filter and its holder or clean these parts using the brush **F3**. Check the condition of the filter and if damaged, replace it with a new one. Insert the filter back into the holder and into the dust container. Secure it in place by turning the grip.
- Insert the dust container back into the vacuum cleaner.



Attention:

Do not wash the dust container or the dust filter in a dishwasher. The dust filter must not be washed using water. Before putting the vacuum cleaner back into operation, check that the dust filter is in its location. Otherwise the vacuum cleaner may be damaged.

MOP UNIT

- After every dry or wet wiping, remove the mop fabric, wash it by hand in lukewarm water with the addition of a small amount of gentle washing powder and allow it to dry naturally.
- Slide the dust container **E1** out of the water tank **E2**, open it and tip out any dirty material. For hygiene reasons, we recommend doing this away from living areas. Empty out the dust container after every use and clean it regularly.
- Take the filter holder **G1** and the dust filter **G2** out of the dust container. Tap out the dust filter and its holder or clean these parts using the brush. Check the condition of the filter and if damaged, replace it with a new one. Insert the filter back into the holder and into the dust container.
- Wash the dust container under running water and dry it well.
- Wipe the water tank using a lightly dampened cloth and then wipe it dry. Take special care to ensure that the contacts **E6** are dry.
- Return the closed dust container back into the water tank.

CENTRAL ROTARY BRUSH

- Push on the latches **H1** of the central rotary brush cover **H2** and take the cover out together with the brush.
- Use a dry wiping cloth to clean out the area in which the rotary brush is housed. Clean out the suction hole as described in the previous paragraph.
- Remove any dirt and material (dust, wound on hair, animal fur, etc.) from the rotary brush and the bearings **H4**.
- Reinsert the rotary brush and its cover.

SUCTION HOLE

- The suction hole **A19** is located underneath the central rotary brush **A21**, therefore, take it out before cleaning the suction hole. With repeat use, dust and dirt may accumulate around the suction hole, which may manifest itself through suction decreased efficiency. Remove the dirt and dust from the suction hole using a soft brush. Regularly clean the suction hole to ensure maximum suction power.

ROTARY BRUSHES

- Take out the rotary brushes **A11** and **A15** by pulling them upwards. Remove any dust and dirt from the location where the brushes were mounted.
- Remove all dust and dirt from the brushes. If necessary you may wash the brushes under running water. If the bristles were deformed while the vacuum cleaner was running, dip them in warm water to allow them to return to their original shape. Allow the brushes to dry before reattaching to the vacuum cleaner.
- After cleaning them, reattach them.



Note:

The rotary brushes become worn out when used. After a certain time it is necessary to replace the used brushes with new ones. To order new brushes, please contact your vendor or an authorised service centre.

COMPLETE ROBOTIC VACUUM CLEANER

- Regularly wipe the surface of the vacuum cleaner including the control panel and the panoramic camera using a soft dry wiping cloth.
- At least once per week or more frequently, clean the front swivel wheel **A9**, the motorized wheels **A13** and **A16**, the suction hole **A19**, rotary brushes **A11** and **A15** and the bottom sensors **A10**, **A12** and **A14**.
- First remove any coarser dirt from the front swivel wheel and the motorised wheels. Then clean them around their entire perimeter using a lightly dampened cloth and wipe them dry. Do not forget to also clean the area around the wheels.
- Wipe the sensors on the underside of the vacuum cleaner using a soft dry wiping cloth or cotton bud.

CHARGING STATION

- At least once per week, clean the surface of the charging bast **B4** including the charging contacts **B5** using a soft dry wiping cloth.

STORAGE

- When not using the vacuum cleaner for an extended period of time, do the following:
 - Clean the vacuum cleaner as described in chapter CLEANING AND MAINTENANCE.
 - Remove the battery from the vacuum cleaner as described in chapter INSERTING AND REMOVING THE BATTERY.
 - Disconnect the charging station from the power socket.
 - Store the vacuum cleaner with all its accessories in a dry, clean and cool place.
 - To prevent the panoramic camera from being damaged, do not place any other items on the vacuum cleaner when it is stored.

TECHNICAL SPECIFICATIONS

Robotic vacuum cleaner

Dimensions (diameter × height).....	335 × 79 mm
Weight.....	2.5 kg
Operating time per single charge.....	up to 120 min
Operating time per single charge when mop is used.....	90-110 min
Dust container capacity.....	475 ml
Water tank capacity.....	0.2 l

Power adapter

Rated voltage range.....	100–240 V AC
Rated frequency.....	50/60 Hz
Output.....	5 V, 1000 mA

Battery

Type.....	2,600 mAh Li-Ion
Charging time.....	4-6 h
Input.....	5 V, 1 A

The declared noise emission level is lower than 65 dB(A), which represents a level A of sound power with respect to a reference sound power of 1 pW.

DISPOSAL OF USED BATTERIES

Prior to handing over the product at a specialised collection facility, it is necessary to ensure that the battery is removed. Prior to removing the battery, turn off the vacuum cleaner using the main switch. Disconnect the battery using the reverse sequence to that described in chapter INSERTING AND REMOVING THE BATTERY.



This symbol indicates that used batteries do not belong in ordinary municipal waste. Hand over used batteries to designated collection points for proper disposal. Correct disposal of batteries will help prevent negative impacts on the environment and human health.

Disposal in other countries outside the European Union.

This symbol is valid in the European Union. If you wish to dispose of used batteries, request the necessary information about the correct disposal method from the local authorities or from your vendor.

INSTRUCTIONS AND INFORMATION REGARDING THE DISPOSAL OF USED PACKAGING MATERIALS

Dispose of used packaging material at a site designated for waste in your municipality.

DISPOSAL OF USED ELECTRICAL AND ELECTRONIC EQUIPMENT



This symbol on products or original documents means that used electric or electronic products must not be added to ordinary municipal waste. For proper disposal, renewal and recycling hand over these appliances to determined collection points. Alternatively, in some European Union states or other European countries you may return your appliances to the local retailer when buying an equivalent new appliance. Correct disposal of this product helps save valuable natural resources and prevents potential negative effects on the environment and human health, which could result from improper waste disposal. Ask your local authorities or collection facility for more details. In accordance with national regulations penalties may be imposed for the incorrect disposal of this type of waste.

For business entities in European Union states

If you want to dispose of electric or electronic appliances, ask your retailer or supplier for the necessary information.

Disposal in other countries outside the European Union.

This symbol is valid in the European Union. If you wish to dispose of this product, request the necessary information about the correct disposal method from the local council or from your retailer.



This product meets all the basic requirements of EU directives related to it.

SENCOR hereby declares that radio device model number SRV 4250SL is in compliance with directive 2014/53/EU. The full wording of the EU Declaration of Conformity is available at the website: www.sencor.eu.