

672080879-00-1V

Room sealed gas continuous flow water heaters

# OptiFlow Professional

GWH12/16/20 1 CTD E23/31 F5 L



**BOSCH**

## Operating Manual



Read installation manual prior to installation of this appliance!  
Read user manual before putting this unit in operation!



Observe the warnings in the manuals!  
The installation location must meet the requirements for sufficient ventilation!



Installation by an authorised person only!

## Index

<b>1</b>	<b>Key to symbols and safety instructions</b>	<b>3</b>
1.1	Key to symbols	3
1.2	Safety Information	3
<b>2</b>	<b>Product details</b>	<b>4</b>
2.1	EC Declaration of Conformity	4
2.2	Type overview	4
2.3	Included Items	5
2.4	Rating plate	5
2.5	Description of appliance	5
2.6	Accessory	5
2.7	Appliance layout	6
<b>3</b>	<b>Operation instructions</b>	<b>7</b>
3.1	Digital display - description	7
3.2	Before first use of the appliance	7
3.3	Switching the appliance on/off	7
3.4	Temperature control	7
3.5	Programming button	8
3.6	Draining the appliance	8
3.7	Error codes	8
3.8	Cleaning the front of the appliance	8
<b>4</b>	<b>Maintenance (only by authorised service technicians)</b>	<b>8</b>
<b>5</b>	<b>Troubleshooting</b>	<b>9</b>
<b>6</b>	<b>Environmental considerations</b>	<b>11</b>
<b>7</b>	<b>Water quality</b>	<b>12</b>
<b>8</b>	<b>Warranty details</b>	<b>13</b>

## 1 Key to symbols and safety instructions

### 1.1 Key to symbols

#### Warnings



Warnings in this document are identified by a warning triangle printed against a grey background.

Keywords at the start of a warning indicate the type and seriousness of the ensuing risk if measures to prevent the risk are not taken.

The following keywords are defined and used in this document:

- **NOTICE** indicates a situation that could result in damage to property or equipment.
- **CAUTION** indicates a situation that could result in minor to medium injury.
- **WARNING** indicates a situation that could result in severe injury or death.
- **DANGER** indicates a situation that will result in severe injury or death.

#### Important information



This symbol indicates important information where there is no risk to people or property.

#### Additional symbols

Symbol	Explanation
▶	Step in an action sequence
→	Cross-reference to another part of the document
•	List entry
–	List entry (second level)

Table 1

### 1.2 Safety Information

#### If you smell gas

A gas leak could potentially cause an explosion. If you smell gas, observe the following rules.

- ▶ Avoid producing flames or sparks:
  - Do not smoke, do not use a lighter or strike matches.
  - Do not operate any electrical switches or unplug any equipment.

- Do not use the telephone or ring doorbells.
- ▶ Turn off the gas supply at the main shut-off valve or at the gas meter.
- ▶ Open windows and doors.
- ▶ Warn your neighbours and leave the building.
- ▶ Prevent anyone from entering the building.
- ▶ Stay well away from the building: call the emergency services and the gas supplier.

#### If you notice dark combustion gases or sooting:

- ▶ Isolate the gas supply to the heater.
- ▶ Notify an authorised technician.

#### Installation, assembly, and modifications

Installation, assembly, and modifications to the heater must only be performed by an authorised technician.

#### Maintenance

- ▶ The water heater is required to have a service and safety inspection every two years.
- ▶ The installer is responsible for the safety and environmental compatibility of the installation.
- ▶ The owner/user is responsible for keeping the area around the water heater free from debris.
- ▶ Safe access to inspect and service the water heater is the responsibility of the property owner.
- ▶ Use only genuine Bosch spare parts.

#### Explosive and flammable material

- ▶ Do not store or use flammable material (paper, spray cans, solvents, paints, etc) near the heater.

#### Combustion air and surrounding air

- ▶ The combustion air and surrounding air must be free from corrosive substances.
- ▶ Do not spray aerosols or use chemicals around the heater unless heater is disconnected from the power supply.

#### Risk of damage due to user error

User errors can result in injury and damage to property.

- ▶ Ensure that children never play with or operate this appliance.
- ▶ Ensure that only personnel who can operate this appliance correctly have access to it.
- ▶ Refer to the operating and user instructions before adjusting the water heater.

#### To be installed and serviced only by an authorised person

The authorised installer is responsible for:

- Correct installation and commissioning of this appliance.
- Ensuring the appliance performs to the specifications stated on the rating label.

- Demonstrating the operation of the appliance to the customer before leaving.
- Handing these instructions to customer.

THIS APPLIANCE IS NOT SUITABLE FOR POOL OR SPA POOL APPLICATIONS.

HANDING THE OPERATING INSTRUCTIONS TO THE CUSTOMER.

NOT SUITABLE FOR COMMERCIAL BOOSTING OF A WARM WATER RECIRCULATION SYSTEM

### Regulations

All local by-laws and regulations pertaining to installation and use of gas appliances must be observed.

This appliance must be installed in accordance with the manufacturers installation instructions, AS/NZS5601, AS/NZS3500, and all Local Building & Gas fitting regulations.

The appliance must not be installed outdoors. The appliance is approved for indoor installation only. Do not install this appliance with any modification or alteration.

Failure to install this appliance in accordance with these installation instructions will void the warranty and may create an unsafe situation.

### Safety of electrical appliances for domestic use and similar purposes

The following requirements apply in accordance with EN 60335-1 in order to prevent hazards from occurring when using electrical appliances:

“This appliance can be used by children of 8 years and older, as well as by people with reduced physical, sensory or mental capabilities or lacking in experience and knowledge, if they are supervised and have been given instruction in the safe use of the appliance and understand the resulting dangers. Children must not play with the appliance. Cleaning and user maintenance must not be performed by children without supervision.”

“If the power cable is damaged, it must be replaced by the manufacturer, its customer service department or a similarly qualified person, so that risks are avoided.”

## 2 Product details

### 2.1 EC Declaration of Conformity

The appliance has been tested and certified to Australian Standards.

<b>Model</b>	GWH12/16/20 1 CTD E23/31 F5 L...
--------------	----------------------------------

Table 2

### 2.2 Type overview

<b>GWH</b>	12	1	CT	D	E	23	F5	L
<b>GWH</b>	12	1	CT	D	E	31	F5	L
<b>GWH</b>	16	1	CT	D	E	23	F5	L
<b>GWH</b>	16	1	CT	D	E	31	F5	L
<b>GWH</b>	20	1	CT	D	E	23	F5	L
<b>GWH</b>	20	1	CT	D	E	31	F5	L

Table 3

[GWH] Gas continuous flow water heater

[12] Capacity (l/min)

[1] Generation

[CT] Thermostatic

[D] Digital user interface

[E] Electric ignition

[23] Appliance set for natural gas

[31] Appliance set for Universal LP gas

[F5] Tight chamber

[L] Locked water temperature adjustment

### 2.3 Included Items

- Gas continuous flow water heater
- Fixing bracket
- Appliance documentation

### 2.4 Rating plate

The rating plate is located on the outside of the appliance, on the bottom.

The rating plate specifies the performance of the appliance, approval and serial numbers.

### 2.5 Description of appliance

- Room sealed wall-mounted appliance for internal installation.
- Multifunctional display panel
- Suitable for Natural Gas or Universal LPG
- Electronic ignition
- Water flow sensor
- Water valve
- Temperature sensors for monitoring the temperature of the incoming and outgoing water of the appliance.
- Safety devices:
  - Flame sensor rod
  - Thermal fuse
  - Hot water temperature sensor
  - Electronic control unit
  - Air temperature sensor
- Electrical connection: 230 V, 50 Hz
- Frost protection device.

### 2.6 Accessory

- Flue accessories
- Remote control (optional).

## 2.7 Appliance layout

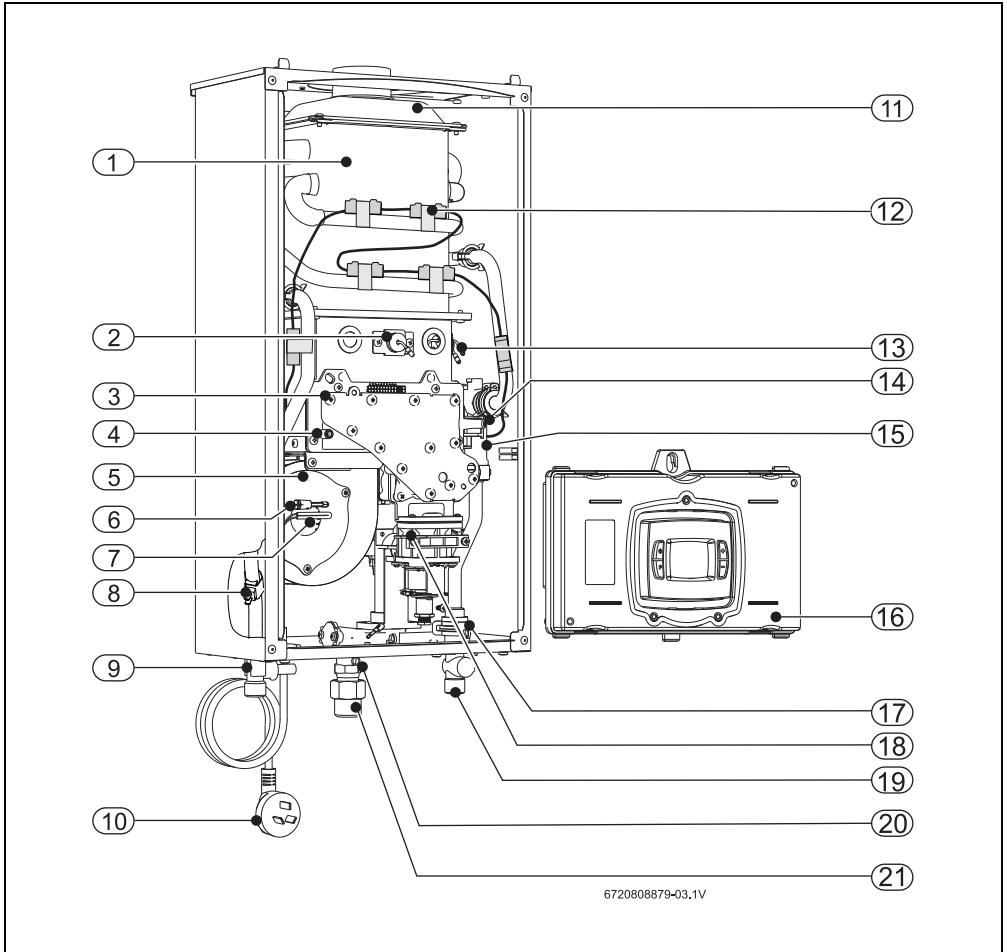

Fig. 1

- |                                  |  |
|----------------------------------|--|
| [1] Heat exchanger               | [13] Ignition electrode                |
| [2] Flame sensor rod             | [14] Burner pressure test point        |
| [3] Burner                       | [15] Water flow sensor and Water valve |
| [4] Air pressure test point      | [16] Electronic control unit           |
| [5] Fan                          | [17] Cold water temperature sensor     |
| [6] Air temperature sensor       | [18] Gas valve                         |
| [7] Thermal fuse                 | [19] Cold water inlet                  |
| [8] Hot water temperature sensor | [20] Gas pressure test point           |
| [9] Hot water outlet             | [21] Gas inlet                         |
| [10] Power cord and plug         |  |
| [11] Combustion gas collector    |  |
| [12] Frost protection device     |  |

### 3 Operation instructions



Open all the water and gas valves.



**CAUTION:** Hot surface!  
The front of the appliance may reach high temperatures.

#### 3.1 Digital display - description

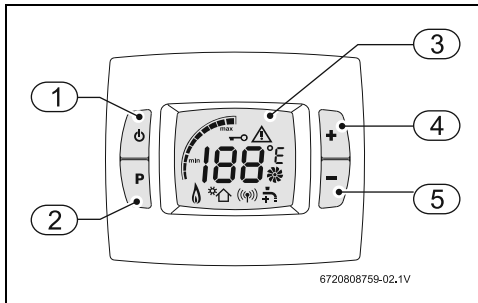

Fig. 2 Digital display

- [1] ON/OFF button
- [2] Programming button
- [3] LCD panel
- [4] Temperature increase button
- [5] Temperature decrease button

#### 3.2 Before first use of the appliance



**CAUTION:**

- ▶ The initial start-up of the water heater must be done by an authorised installer who will hand the customer the operating instructions.

- ▶ Check that the type of gas indicated on the rating plate is the same as the gas to which the appliance is connected.
- ▶ Plug in the appliance to the electrical socket and switch on.
- ▶ Open the gas isolation valve of the installation.
- ▶ Open the water isolation valve of the installation.

#### 3.3 Switching the appliance on/off

##### Switching on the appliance



By default, the heating temperature of the water is:  
55°C preset appliances: 55°C  
50°C compliant appliances: 50°C

- ▶ Press the button .  
The screen cover shows the selected water temperature.

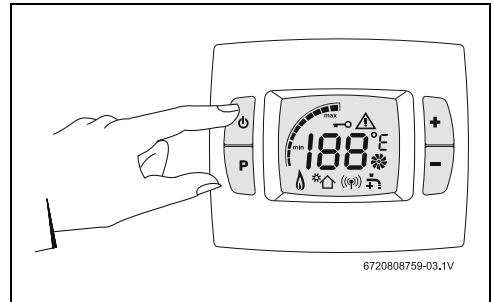

Fig. 3

##### Switching the appliance off

- ▶ Press the button .

#### 3.4 Temperature control



The temperature indicated on the LCD display matches the pre-selected temperature.

- ▶ Press the buttons or until you reach the desired temperature.

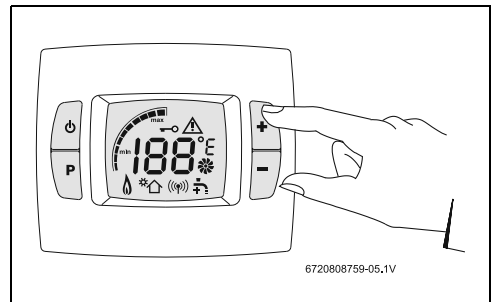

Fig. 4

By selecting the temperature and only turning on the hot tap, energy and water consumption can be reduced.



### CAUTION:

The temperature indication on the display is approximate, always confirm with your hand before bathing children or old people.

## 3.5 Programming button

### Setting the water temperature

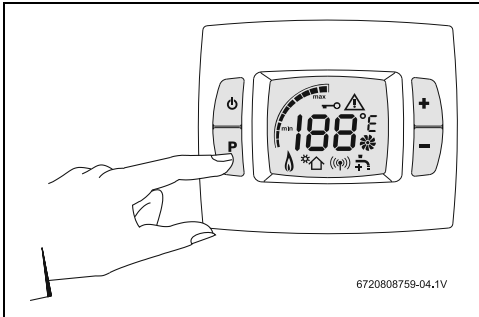

Fig. 5

- ▶ Press the buttons **+** or **-** to select the desired temperature.
- ▶ Press the **P** button for 3 seconds to set the temperature.

When the display stops flashing, the temperature is set in the memory.

### Selecting the preset temperature

To select the preset temperature.

- ▶ Press the **P** button for 1 second.

The display will show the preset temperature and will supply water at that temperature.

## 3.6 Draining the appliance



### NOTICE:

Not draining the appliance when a freezing risk exists may damage components of the appliance.



Beforehand place a container below the appliance to collect all the water that comes out of the appliance.

If draining the appliance is required, the following process should be followed:

- ▶ Shut off the cold water isolation valve on the cold water inlet off the appliance.
- ▶ Open a hot water tap.
- ▶ Remove the connection to the cold water pipe.
- ▶ Empty all the water contained inside the appliance.



Turning off the power to the appliance will disable the frost protection circuit. If switching of power is required, the appliance **MUST** be drained.

## 3.7 Error codes

See table 4 on page 9.

### Resetting the appliance

Some error codes may be solved by resetting the appliance:

- ▶ Press the button  for 3 seconds.

## 3.8 Cleaning the front of the appliance

- ▶ Only clean the front of the appliance with a cloth and detergent with water.



Do not use corrosive and/or abrasive detergents.

## 4 Maintenance (only by authorised service technicians)

To guarantee that the consumption of gas and the emission of exhaust gas are maintained at the best values, we recommend that the appliance be inspected every two years and if necessary, maintenance works be carried out.



Maintenance must only be performed by an authorised service technician.

- ▶ Your appliance should only be attended to by a Bosch service agent. Call for service contract details: AU 1300 30 70 37, NZ 0800 54 33 52.

## 5 Troubleshooting

Fitting, maintenance and repair must only be carried out by authorised technicians. The following table describes the possible solutions.

Display	Description	Possible solution
A0	Cold and hot water temperature sensor damaged.	<ul style="list-style-type: none"> <li>▶ Check temperature sensor and associated connections.</li> <li>▶ If the problem persists, call an authorised service technician.</li> </ul>
A1	Temperature inside the water heater housing is high (heat exchanger calcified or sooted).	<ul style="list-style-type: none"> <li>▶ The appliance automatically regulates its performance to avoid overheating.</li> <li>▶ If the problem persists, call an authorised service technician.</li> </ul>
A4	Faulty air temperature sensor.	<ul style="list-style-type: none"> <li>▶ Call an authorised service technician.</li> </ul>
A7	Faulty hot water outlet temperature sensor.	<ul style="list-style-type: none"> <li>▶ Check temperature sensor and associated connections.</li> <li>▶ If the problem persists, call an authorised service technician.</li> </ul>
A9	Hot water outlet temperature sensor is not fitted properly. Low incoming gas pressure.	<ul style="list-style-type: none"> <li>▶ Check temperature sensor and associated connections.</li> <li>▶ If the problem persists, call an authorised service technician.</li> </ul>
C7	Faulty fan.	<ul style="list-style-type: none"> <li>▶ Check if the fan is properly connected to ECU.</li> <li>▶ If the problem persists, call an authorised service technician.</li> </ul>
CA	Water flow above maximum specified value.	<ul style="list-style-type: none"> <li>▶ Check incoming water pressure.</li> <li>▶ Install a pressure limiting valve if necessary.</li> </ul>
CF	Blocked flue gas outlet.	<ul style="list-style-type: none"> <li>▶ Remove dirt or any other impediment from the flue terminal and/or pipe.</li> </ul>
C1	Air flow insufficient for start-up.	<ul style="list-style-type: none"> <li>▶ Close and open a hot water tap.</li> <li>▶ If the problem persists, call an authorised service technician.</li> </ul>
E0	Failure of control module	<ul style="list-style-type: none"> <li>▶ Unplug the electrical connection for 10 seconds.</li> <li>▶ Reconnect and restart the appliance.</li> <li>▶ If the problem persists, call an authorised service technician.</li> </ul>
E1	Hot water temperature sensor detects overheating.	<ul style="list-style-type: none"> <li>▶ Let the appliance cool and try again.</li> <li>▶ If the problem persists, call an authorised service technician.</li> </ul>

Table 4

Display	Description	Possible solution
E2	Faulty inlet water temperature sensor.	<ul style="list-style-type: none"> <li>▶ Check temperature sensor and associated connections.</li> <li>▶ If the problem persists, call an authorised service technician.</li> </ul>
E4	Air temperature sensor detects overheating (leaking combustion products inside the combustion chamber).	<ul style="list-style-type: none"> <li>▶ Switch off at the power point and remove the plug from the electrical socket.</li> <li>▶ Do not try to Restart the appliance.</li> <li>▶ Call a service agent immediately.</li> </ul>
E9	Activated thermal fuse.	<ul style="list-style-type: none"> <li>▶ Call an authorised service technician.</li> </ul>
EA	Flame not detected.	<ul style="list-style-type: none"> <li>▶ Check that the gas to the appliance has not been turned off.</li> <li>▶ Unplug the electrical connection for 10 seconds.</li> <li>▶ Reconnect and restart the appliance.</li> <li>▶ If the problem persists, call an authorised service technician.</li> </ul>
EE	Modulating solenoid valve disconnected.	<ul style="list-style-type: none"> <li>▶ Check solenoid connections.</li> <li>▶ If the problem persists, call an authorised service technician.</li> </ul>
EF	Wrong gas connected.	<ul style="list-style-type: none"> <li>▶ Call an authorised service technician.</li> </ul>
F7	A flame is detected although the appliance is switched off.	<ul style="list-style-type: none"> <li>▶ Unplug the electrical connection for 10 seconds.</li> <li>▶ Reconnect and restart the appliance.</li> <li>▶ If the problem persists, call an authorised service technician.</li> </ul>
F9	Safety solenoid valve disconnected.	<ul style="list-style-type: none"> <li>▶ Call an authorised service technician.</li> </ul>
FA	Fault in the gas control valve.	<ul style="list-style-type: none"> <li>▶ Call an authorised service technician.</li> </ul>
FC	Buttons stuck in a “pressed” position for more than 30 seconds.	<ul style="list-style-type: none"> <li>▶ Release the button.</li> <li>▶ If the problem persists, call an authorised service technician.</li> </ul>
With indication,  	The temperature selected is lower than the minimum power that the appliance supplies.	<ul style="list-style-type: none"> <li>▶ Increase the hot water flow.</li> </ul>
With indication   and water temperature low.	High incoming water temperatures, or low flow rate can create this occurrence.	<ul style="list-style-type: none"> <li>-or-</li> <li>▶ Select a higher temperature.</li> <li>▶ If the problem persists:</li> <li>▶ Call an authorised service technician.</li> </ul>
	Appliance is making a resonance noise (vibration).	<ul style="list-style-type: none"> <li>▶ Call an authorised service technician.</li> </ul>

Table 4

Note: breakdowns diagnosed by the water heater through an indication in the LCD panel result in the blocking of the appliance for safety reasons. Once the problem is solved, you have to press the on/off button for > 3 seconds to restart the appliance.

To locate your nearest service agent, call: AU 1300 30 70 37, NZ 0800 54 33 52.

---

## 6 Environmental considerations

Environmental protection is a fundamental corporate strategy of the Bosch Group.

The quality of our products, their efficiency and environmental safety are all of equal importance to us and all environmental protection legislation and regulations are strictly observed.

We use the best possible technology and materials for protecting the environment taking into account of economic considerations.

### Packaging

We participate in the recycling programmes of the countries in which our products are sold to ensure optimum recycling.

All of our packaging materials are environmentally friendly and can be recycled.

### Used appliances

Used appliances contain valuable materials that should be recycled.

The various assemblies can be easily dismantled and synthetic materials are marked accordingly. Assemblies can therefore be sorted by composition and passed on for recycling or disposal.

## 7 Water quality

All Bosch water heating appliances are constructed from high quality materials and components and all are certified for compliance with relevant parts of Australian and New Zealand gas, electrical and water standards.

Whilst Bosch water heaters are warranted against defects, the warranty is conditional upon correct installation and use, in accordance with detailed instructions provided with the heater. In the case of the water supplied to the heater, it is important that the water quality be of an acceptable standard.

The water quality limits/parameters listed in water quality table are considered acceptable and generally, Australian and New Zealand suburban water supplies fall within these limits/parameters.

In areas of Australia and New Zealand where water may be supplied, either fully or partly, from bores, artesian wells or similar, one or more of the important limits may well be exceeded and the heater could, therefore, be at risk of failure.

Where uncertainty exists concerning water quality, intending appliance users should seek a water analysis from the water supplying authority and in cases where it is established that the water supply does not meet the quality requirements of the water quality table, the Bosch warranty would not apply.

### Water quality table

Maximum levels

pH	Saturation Index (LSI) (Langgeller)	Total Hardness	Chlorides	Sodium	Iron
6.5-9.0	+0.4 to -1.0 at 65 °C	200 mg/l	250 mg/l	180 mg/l	1 mg/l

Table 5

## 8 Warranty details

### Robert Bosch (Australia) Pty Ltd (Bosch) Manufacturer's Warranty (Applicable for purchases from 1 January 2012)

All Bosch hot water units are carefully checked, tested and subject to stringent quality controls.

#### 1. Warranty

Bosch offers, at its option, to repair or exchange this Bosch hot water unit or the relevant part listed in clause 2 below at no charge, if it becomes faulty or defective in manufacture or materials during the warranty period also stated in clause 2. This warranty is offered in addition to any other rights or remedies held by a consumer at law.

#### 2. Warranty periods & coverage

- (a) Domestic applications: 3 years (parts and labour)
- (b) Heat exchangers used in domestic applications: 12 years (parts only)
- (c) Commercial applications: 12 months (parts and labour)
- (d) Heat exchangers used in commercial applications: 12 months (part and labour)

All warranty periods commence on the date of purchase of the hot water unit by the end-user. However, where the date of purchase by the end-user is more than 24 months after the date of manufacture, all warranty periods will automatically commence 24 months after the date of manufacture.

#### 3. Warranty exclusions

This warranty is VOID if any damage to or failure of the hot water unit is caused wholly or partly by:

- (a) faulty installation
- (b) neglect, misuse, accidental or non-accidental damage, failure to follow instructions
- (c) use of the unit for purposes other than which it was designed or approved
- (d) unauthorised repairs or alterations to the unit without Bosch's consent
- (e) use of unauthorised parts and accessories without Bosch's consent
- (f) use of non-potable water or bore water in the hot water unit (see product instructions for further details)
- (g) continued use after a fault becomes known or apparent.

This warranty DOES NOT include:

- (a) costs of consumables or accessories
- (b) wear and tear, normal or scheduled maintenance
- (c) to the extent permitted by law, any damage to property, personal injury, direct or indirect loss, consequential losses or other expenses
- (d) changes in the condition or operational qualities of the hot

water unit due to incorrect storage or mounting or due to climatic, environmental or other influences.

NOTE: Any service call costs incurred by the owner or user of the hot water unit for any matter not covered by the terms of this warranty will not be reimbursed by Bosch, even if those costs are incurred during the warranty period. If the hot water unit is located outside the usual operating area of a Bosch service agent, the agent's travel, freight or similar costs are not covered by this warranty and must be paid by the owner or user of the hot water unit.

#### 4. Warranty conditions

- (a) Proof of purchase may be required.
- (b) The hot water unit must be installed by an authorised and licensed installer.
- (c) Proof may be required of the date of installation and correct commissioning of the hot water unit has been carried out to Bosch's satisfaction (such as a certificate of compliance).
- (d) Repair or replacement of the hot water unit or any parts under this warranty does not lengthen or renew the warranty period.
- (e) This warranty is not transferable and is only offered to the original purchaser of the hot water unit.
- (f) No employee or agent of Bosch is authorised to amend the terms of this warranty.
- (g) This warranty only applies to Bosch hot water units purchased from an authorised reseller and installed in Australia or New Zealand.
- (g) To the extent that any condition or warranty implied by law is excludable, such condition or warranty is excluded.

#### 5. How to lodge a warranty claim and warranty procedure

- (a) Warranty claims must be made with the Bosch Customer Contact Centre (Australia: ph 1300 307 037; New Zealand: ph 0800 543 352). Please be ready to provide the model and serial numbers, date of installation, purchase details and a full description of the problem. Warranty claims must be made before the end of the warranty period.
- (b) All warranty service calls must be conducted by an authorised Bosch service agent.
- (c) Invoices for attendance and repair of a hot water unit by third parties not authorised by Bosch will not be accepted for payment by Bosch.

#### 6. Privacy Act 1988 (Cth)

A customer's personal information collected during warranty claims may be used for the provision of customer support, for the provision of information about products and services and for other marketing activities undertaken by Bosch and its Bosch Service Agents who are authorised to carry out warranty repairs on behalf of Bosch (Purpose). Bosch is committed to protecting the privacy of its customers' personal information. It will act in compliance with the National Privacy Principles and

Privacy Act 1988 (Cth). Bosch will not forward customers' personal information to third parties other than for the Purpose. A customer can object at any time to the use of their personal information for the Purpose. Bosch will cease to use a customer's personal information accordingly if an objection is made.

### **7. Bosch contact details**

If you have any questions about this warranty or to lodge a warranty claim, please contact:

Robert Bosch (Australia) Pty Ltd  
1555 Centre Road, Clayton, Victoria 3168  
Tel: Australia: 1300 307 037  
Tel: New Zealand: 0800 543 352

### **IMPORTANT NOTE FOR AUSTRALIAN CONSUMERS**

Our goods come with guarantees that cannot be excluded under the Australian Consumer Law. You are entitled to a replacement or refund for a major failure and for compensation for any other reasonably foreseeable loss or damage. You are also entitled to have the goods repaired or replaced if the goods fail to be of acceptable quality and the failure does not amount to a major failure.

## Notes



6720813939

Robert Bosch (Australia) Pty Ltd  
Thermotechnology Division  
1555 Centre Road  
Clayton Victoria 3168

Australia  
Phone: 1300 30 70 37  
Fax: 1300 30 70 38  
[www.bosch-climate.com.au](http://www.bosch-climate.com.au)

New Zealand  
Phone: 0800 54 33 52  
Fax: 0800 54 33 55  
[www.bosch-climate.co.nz](http://www.bosch-climate.co.nz)