

Progressive Industries

Instruction Manual

Smart Surge Protector (SSP) SSP-30XL & SSP-50XL



SSP-30XL



SSP-50XL

Instructions

SPECIFICATIONS:

Model	SSP-30XL	SSP-50XL
Rated:	120V	120/240V
Joule Rating:	825J	1,650J
Surge Amps:	22,500	45,000
Response Time:	<1 Nano Seconds	<1 Nano Seconds

FEATURES INCLUDE:

- (3) Color LED indicator lights
- Weather resistant
- Dual line polarity tester (SSP-50XL only)
- Pull handle on plug
- Limited lifetime warranty
- It's portable, just plug it in

INSTALL STEPS:

STEP 1: Plug Smart Surge Protector into AC power. DO NOT plug in your RV at this time. Verify GREEN surge indicator LED(s) is on.

STEP 2: Verify which LED's come on.

The **Correct Wiring** condition occurs when both the GREEN and BLUE LED's are on. If this does not occur you may be experiencing one of the other three (3) wiring conditions as noted in the diagrams:

- A** Reverse Polarity
Open Neutral
- B** Open Ground
- C** Your Smart Surge Protector will continue to work during any of the wiring conditions; however, only the Correct Wiring condition (both GREEN & BLUE LED's on) is optimal and any other wiring condition should be corrected by Campground Maintenance before use.
- D**

STEP 3: Plug in your RV power to the Smart Surge Protector Refer to STEP 2 above for surge protection wiring conditions.

LED INDICATORS:

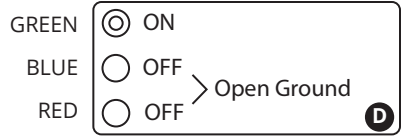
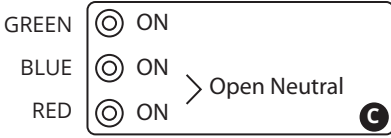
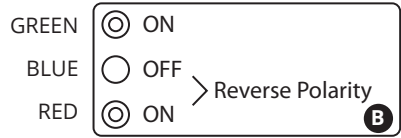
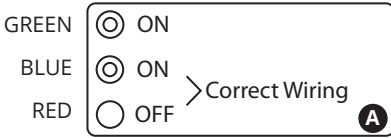

Note: Green light off indicates a surge occurrence.

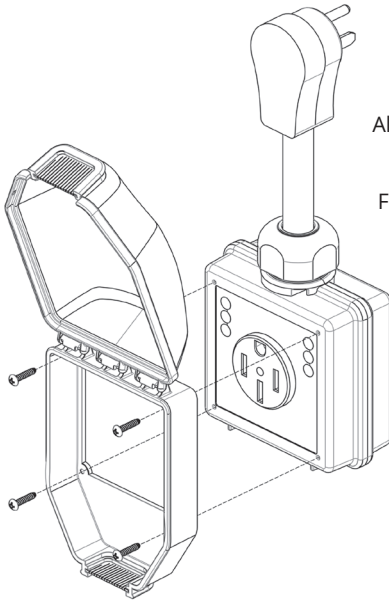

SSP-50XL & SSP30XL

All weather shield assembly
 installation diagram

Four (4) screws included in
 the hardward kit

Progressive Industries, Inc.

For more information regarding the Limited Lifetime Warranty, Troubleshooting and the Warranty Claim Form visit:

www.progressiveindustries.net

Note: Lifetime warranty excludes All Weather Shield assembly.

Technical Support

- **919.267.6964**
- Tech@progressiveindustries.net