



9-IN-1 AIRPRO XL GRILL

Instruction Manual



Thank You for your purchase

Register & sign up for special
announcements and trendy recipes!

Tell us what you think!
Rate, review or ask us a question.

@bellahousewares.com
#getinspired



BellaLife



BellaLifestyle

TABLE OF CONTENTS

Important Safeguards.....	4-6
Additional Important Safeguards.....	7-8
Notes on the Plug.....	8
Notes on the Cord.....	8
Plasticizer Warning.....	9
Electric Power.....	9
Getting To Know Your 9-in-1 AirPro XL Grill	10
Control Panel.....	11-12
Before Using for the First Time	13
Operating Instructions.....	13
Preheating.....	13
Air Fry.....	14-15
Grill	16
Roast.....	17
Bake	18-19
Broil	20
Sauté	21
Sear.....	22
Pizza.....	23-24
Dehydrate	25
User Maintenance Instructions.....	26
Care & Cleaning Instructions	26
Storing Instructions.....	27
Trouble Shooting	27
Cooking Charts.....	28-33
Grill.....	28
Roast	29
Bake.....	29
Air Fry	30-32
Dehydrate	32-33
Warranty	34-35

IMPORTANT SAFEGUARDS

When using electrical appliances, basic safety precautions should always be followed, including the following:

1. **READ ALL INSTRUCTIONS.**
2. Remove and discard the protective cover fitted on the power plug of this appliance.
3. This appliance can be used by persons with reduced physical, sensory or mental capabilities or lack of experience and knowledge if they have been given supervision or instruction concerning use of the appliance in a safe way and understand the hazards involved.
4. Keep the appliance and its cord out of reach of children. **DO NOT** allow the appliance to be used by children. Close supervision is necessary when used near children.
5. This appliance is for household use only. **DO NOT** use this appliance for anything other than its intended use. **DO NOT** use in moving vehicles or boats. **DO NOT** use outdoors. Misuse may cause injury.
6. Ensure the surface is level, clean and dry. **DO NOT** place the appliance near the edge of a countertop during operation.
7. **ALWAYS** ensure the appliance is properly assembled before use.
8. When using this appliance, provide at least 6 inches (15.25 cm) of space above and on all sides for air circulation.
9. **DO NOT** use an extension cord. A short power-supply cord is used to reduce the risk of children grabbing the cord or becoming entangled and to reduce the risk of people tripping over a longer cord.
10. To protect against electrical shock **DO NOT** immerse cord, plugs, or main unit housing in water or other liquid.

11. DO NOT use the appliance if there is damage to the power cord or plug. Regularly inspect the appliance and power cord. If the appliance malfunctions or has been damaged in any way, immediately stop use and call Customer Service.
12. NEVER use outlet below countertop surface.
13. DO NOT place appliance and let cord hang over edges of tables, counters or touch hot surfaces.
14. Only use recommended accessories included with this appliance or authorized by 9-in-1 AirPro XL Grill. The use of accessories or attachments not recommended by 9-in-1 AirPro XL Grill may cause a risk of fire or injury.
16. Before placing any accessory into the cooker, ensure they are clean and dry.
17. DO NOT use the appliance without the removable cooking pot and splatter shield installed.
18. ALWAYS ensure hood is fully closed before operating.
19. DO NOT move the appliance when in use.
20. DO NOT cover the air intake vent or air outlet vent while unit is operating. Doing so will prevent even cooking and may damage the unit or cause it to overheat.
21. DO NOT touch hot surfaces. Appliance surfaces are hot during and after operation. To prevent burns or personal injury, ALWAYS use protective hot pads or insulated oven mitts and use available handles and knobs.

22. DO NOT touch accessories during or immediately after cooking. The grilling plate and basket becomes extremely hot during the cooking process. Avoid physical contact while removing the accessory from the appliance. To prevent burns or personal injury ALWAYS use care when interfacing with product. Recommend use of long handed utensil and protective hot pads or insulated oven mitts.
23. DO NOT use this appliance for deep-frying.
24. To prevent possible illness, ALWAYS use a thermometer to check that your food is cooked to the recommended temperatures.
25. should a grease fire occur or the unit emits black smoke, unplug immediately. Wait for smoking to stop before removing any cooking accessories.
26. Please refer to the Cleaning & Maintenance section for regular maintenance of the appliance.
27. Unplug from outlet when not in use and before cleaning. Allow to cool before cleaning, disassembly, putting in or taking off parts and storage.
28. DO NOT clean with abrasive cleaners, steel wool, or scouring pads.
29. Cleaning and user maintenance shall not be made by children.

FOR HOUSEHOLD USE ONLY
SAVE THESE INSTRUCTIONS

ADDITIONAL IMPORTANT SAFEGUARDS

CAUTION, HOT SURFACES: This appliance generates heat and escaping steam during use. Proper precautions must be taken to prevent the risk of burns, fires or other injury to persons or damage to property.

1. A person who has not read and understood all operating and safety instructions is not qualified to operate this appliance. All users of this appliance must read and understand this instruction manual before operating or cleaning this appliance.
2. If this appliance falls or accidentally becomes immersed in water, unplug it from the wall outlet immediately. **Do not reach into the water!**
3. To reduce the risk of fire, do not leave this appliance unattended during use.
4. If this appliance begins to malfunction during use, immediately press the POWER button and unplug the cord. Do not use or attempt to repair a malfunctioning appliance!
5. When using this appliance, provide adequate air space above and on all sides for air circulation. Do not operate this appliance while it is touching or near curtains, wall coverings, clothing, dishtowels or other flammable materials.
6. Do not use this appliance in an unstable position.
CAUTION: To protect against damage or electric shock, do not cook in the base.

7. The cord of this appliance should only be plugged into a 120V AC electrical wall outlet
8. To reduce the risk of burns or other injuries, do not touch hot surfaces. Use a protective oven mitts or gloves as well as long-handled utensils is recommended.

NOTES ON THE PLUG

This appliance has a polarized plug (one blade is wider than the other). To reduce the risk of electric shock, this plug will fit in a polarized outlet only one way. If the plug does not fit fully into the outlet, reverse the plug. If it still does not fit, contact a qualified electrician. Do not modify the plug in any way.

NOTES ON THE CORD

- A. A short power-supply cord (or detachable power-supply cord) is to be provided to reduce risks resulting from becoming entangled in or tripping over a longer cord.
- B. Longer detachable power-supply cords or extension cords are available and may be used if care is exercised in their use.
- C. If a long detachable power-supply cord or extension cord is used:
 - 1) The marked electrical rating of the detachable power-supply cord or extension cord should be at least as great as the electrical rating of the appliance;
 - 2) If the appliance is of the grounded type, the extension cord should be a grounding- type 3-wire cord; and
 - 3) The longer cord should be arranged so that it will not drape over the counter top or table top where it can be pulled on by children or tripped over.

PLASTICIZER WARNING

CAUTION: To prevent Plasticizers from migrating from the finish of the counter top or table top or other furniture, place NON-PLASTIC coasters or place mats between the appliance and the finish of the counter top or table top. Failure to do so may cause the finish to darken; permanent blemishes may occur or stains can appear.

ELECTRIC POWER

If the electrical circuit is overloaded with other appliances, your appliance may not operate properly. It should be operated on a separate electrical circuit from other appliances.

Getting To Know Your 9-in-1 AirPro XL Grill

Product may vary slightly from illustration

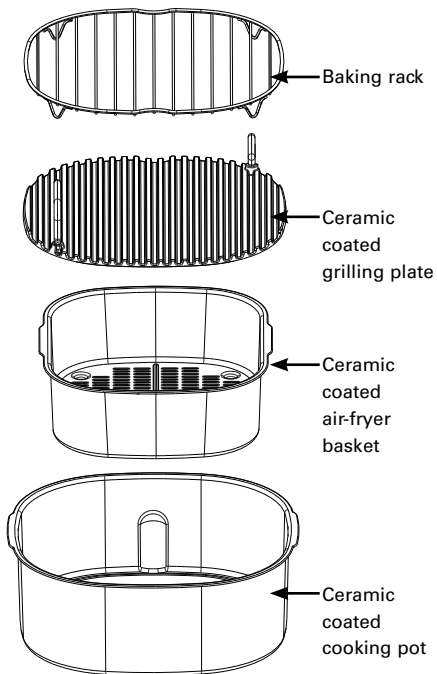
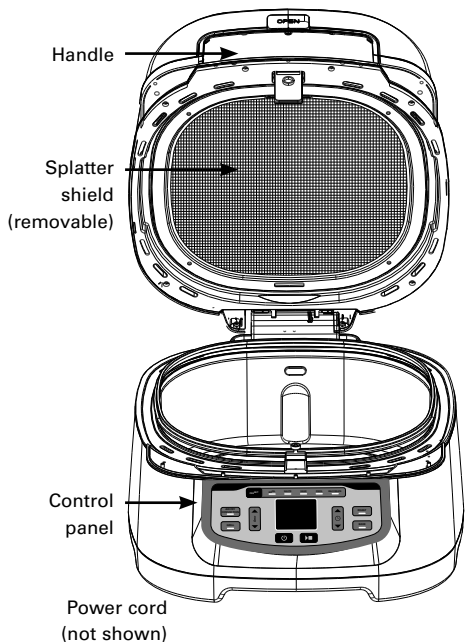









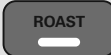

Control Panel



GETTING TO KNOW YOUR 9-in-1 AirPro XL Grill

Part of the panel function status diagram and key instructions

	Air Fry Convection button with indicator light		Roast button with indicator light
	Grill button with indicator		Bake button with indicator light
	Temperature setting button (up and down) Press this key to set the temperature in any function or modify the time during cooking.		Time setting button (up and down) Press this key to set the time in any function or modify the time during cooking.
	Power on/off button Start up/shut down the unit		Start/Cancel Function. After selecting the function, press Start/Cancel to begin cooking
	Function settings button		Display showing remaining time on top and Temperature in °F on bottom.
	Menu selection button		Press PRESET button to choose the cooking function. Indicator lights for selectable functions: Broil, Sauté, Sear, Pizza and Dehydrate.

Before Using for the First Time

1. Remove all packing material and labels from the inside and outside of the 9-in-1 AirPro XL Grill. Check that there is no packaging underneath and around the frying basket.
2. Place the unit on a flat, clean work area.
3. Wash frying basket, grill plate and cooking pot in hot, soapy water.
4. DO NOT IMMERSE THE AIR FRYER BODY IN WATER. Wipe the air fryer body with a damp cloth. Dry all parts thoroughly.

Operating Instructions

WARNING! This 9-in-1 AirPro XL Grill should not be used to boil water.

NOTE: During first use, the appliance may emit a slight odor. This is normal.

1. Place the 9-in-1 AirPro XL Grill on a flat, heat-resistant work area, close to an electrical outlet.
2. Keep the cooking pot into the base of the unit and insert the air frying basket or grill plate depending on the cooking mode to be used.
3. Arrange food on tray. Do not overfill frying basket with food. To ensure proper cooking and air circulation, NEVER fill any frying basket more than 2/3 full.
4. Plug cord in the wall outlet
5. To begin press power button and the Display will illuminate.

Preheating

Preheating the unit is strongly recommended for best results. This process will start automatically after selecting some cooking function and it can take several minutes depending on the cooking mode and temperature selected.

Air Fry

1. Place the cooking pot in the unit and then place the Air Fryer basket inside the pot.

NOTE: The main unit has a rear bump that must be aligned with the indent on the pot. Ensure the splatter shield is in place and close the lid. (See Figure 1)

2. Press the **AIR FRY CONVECTION** button. The Display will show the default time (20 min) and temperature (400 °F).

3. Use the up and down **TEMP** arrows to adjust the temperature and the up and down **TIME** arrows to set the cooking time.

Temperature adjustment range:

from 300 °F to 450 °F.

Time adjustment range:

from 1 min to 60 mins.

4. Press the **START/STOP** button to begin preheating. Progress bar will appear on the display screen. It can take several minutes to preheat, depending on the selected temperature setting.
5. When preheating is complete, the unit will beep and **"Add Food"** will flash across on the display screen.
6. Open the lid and place food in the basket. Once the lid is closed, cooking will begin and the timer will start counting down.

Figure 1

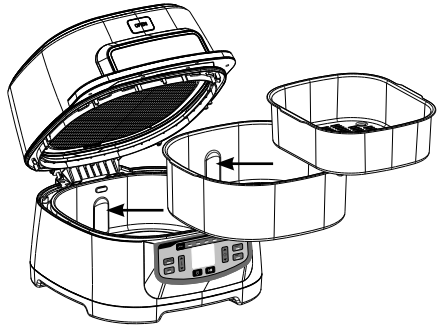

7. For best results, shaking ingredients frequently is recommended. When you open the lid, the unit will pause. Use silicone tipped tongs when tossing your food or oven mitts to shake the basket. (See Figure 2)

After shaking the food, place the basket in the unit and close the lid. Cooking will automatically resume after hood is closed.

8. When cooking time is complete, the unit will beep and **END** will appear on the display screen. Keep the lid open after removing your food so the unit will cool down faster.

NOTE: If you need to cook your food longer, simply press the **TIME** up arrow to add more time, then press the **START/STOP** button.

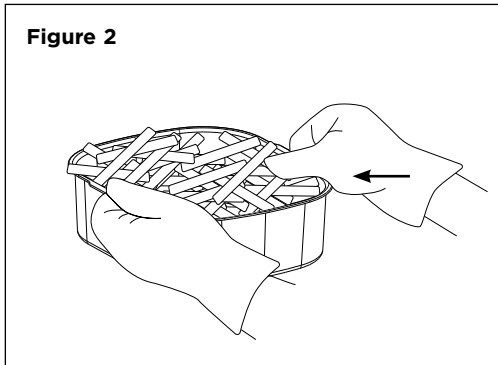

Grill

1. Place the cooking pot in the unit and then place the grilling plate inside the pot.
NOTE: The main unit has a rear bump that must be aligned with the indent on the pot and also with the curve on the grilling plate. Ensure the splatter shield is in place and close the lid. (See Figure 3)

2. Press the **GRILL** button. The display will show the default time (10 min) and temperature (500 °F).

3. Press up and down **TEMP** arrows to adjust the temperature setting and press **TIME** arrows to adjust the cooking time.
Temperature adjustment range: from 400 °F to 510 °F.
Time adjustment range: from 1 min to 30 mins.

4. Press the **START/STOP** button to start the preheating process. The display will show a progress bar.

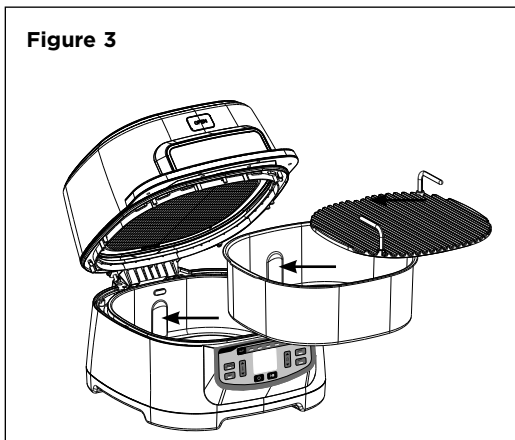

5. Once the preheating is complete, the unit will beep and **"Add Food"** will flash across on the display screen.
6. Open the lid and add your food on the grilling plate. After closing the lid, the timer will automatically begin and display will show the countdown.
NOTE: During the cooking process, you can open the lid to check on or flip your food. The timer will pause when the lid is open and then automatically resume after it is closed.
7. Once the cooking has finished, the unit will beep, and the display will show **"END"**
8. After removing your food, keep the unit open to allow it to cool down faster.
NOTE: If batch cooking, empty the oil from the removable cooking pot before cooking the next batch. This will help prevent grease from burning and causing smoke.

Roast

1. Place the cooking pot in the unit aligning the bump with the indent on the pot. Ensure the splatter shield is in place and close the lid. (See Figure 4)
2. Press the **ROAST** button. The display will show the default time (15 min) and temperature (375 °F).
3. Use the up and down **TEMP** arrows to adjust the temperature and the up and down **TIME** arrows to set the cooking time.
Temperature adjustment range: from 250 °F to 500 °F.
Time adjustment range: from 1 min to 4 hours.
4. Press the **START/STOP** button to begin preheating. Progress bar will appear on the display screen. It can take several minutes to preheat, depending on the selected temperature setting.
5. When preheating is complete, the unit will beep and **"Add Food"** will flash across on the display screen.
6. Open the lid and place food in the pot. Once the lid is closed, cooking will begin and the timer will start counting down.
NOTE: During the cooking process, you can open the lid to check on or flip your food. The timer will pause when the lid is open and then automatically resume after it is closed.
7. When cooking time is complete, the unit will beep and **END** will appear on the display screen. Keep the lid open after removing your food so the unit will cool down faster.
NOTE: If you need to cook your food longer, simply press the **TIME** up arrow to add more time, then press the **START/STOP** button.

Figure 4

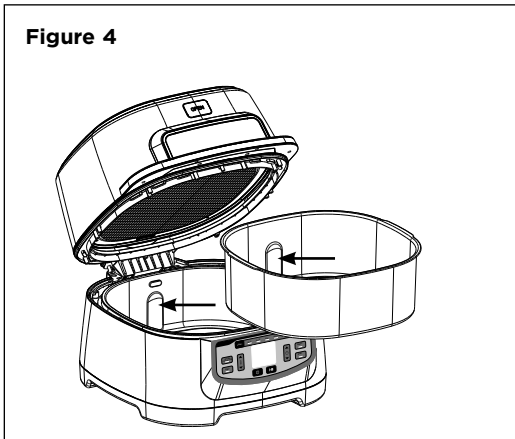

Bake

1. Place the cooking pot in the unit aligning the bump with the indent on the pot. Ensure the splatter shield is in place and close the lid. (See Figure 5)
2. Press the **BAKE** button. The Display will show the default time (15 min) and temperature (300 °F).
3. Use the up and down **TEMP** arrows to adjust the temperature and the up and down **TIME** arrows to set the cooking time.
Temperature adjustment range: from 250 °F to 400 °F.
Time adjustment range: from 1 hour to 2 hours.
4. Press the **START/STOP** button to begin preheating. Progress bar will appear on the display screen. It can take several minutes to preheat, depending on the selected temperature setting.
5. When preheating is complete, the unit will beep and **"Add Food"** will flash across on the display screen.

Figure 5

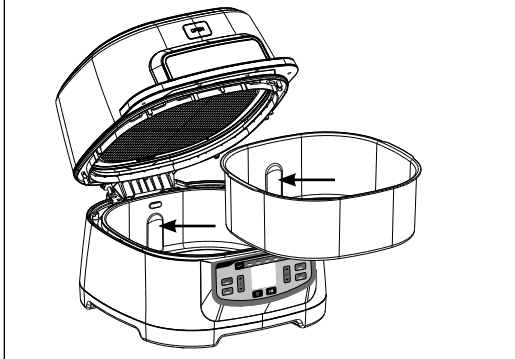

6. Open the lid and set your bake pan on the baking rack. Once the lid is closed, cooking will begin and the timer will start counting down. (See Figure 6)

NOTE: During the cooking process, you can open the lid to check on. The timer will pause when the lid is open and then automatically resume after it is closed.

7. When cooking time is complete, the unit will beep and **END** will appear on the display screen. Keep the lid open after removing your food so the unit will cool down faster.

NOTE: If you need to cook your food longer, simply press the **TIME** up arrow to add more time, then press the **START/STOP** button.

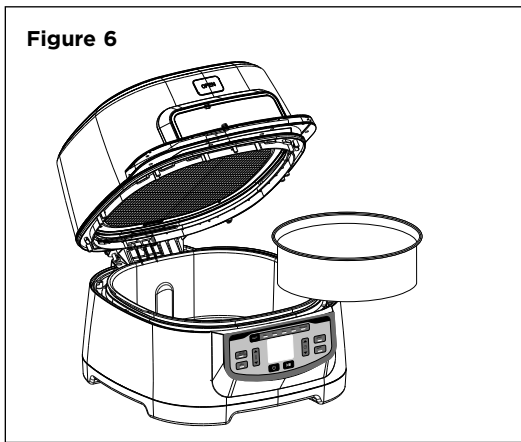

Broil

1. Place the cooking pot in the unit aligning the rear bump on the unit with the indent on the pot. Ensure the splatter shield is in place and close the lid. (See Figure 7)
2. Press the **PRESET** button once. The **BROIL** indicator light illuminates. The display will show the default time (10 mins) and temperature (450 °F).
3. Use the up and down **TIME** arrows to set the cooking time. **Time adjustment range: from 1 min to 30 mins.**
4. Press the **START/STOP** button to begin preheating. Progress bar will appear on the display screen. It can take several minutes to preheat, depending on the selected temperature setting.
5. When preheating is complete, the unit will beep and **"Add Food"** will flash across on the display screen.
6. Open the lid and place food in a oven safe dish directly in the cooking pot. Once the lid is closed, cooking will begin and the timer will start counting down.
NOTE: During the broiling process, you can open the lid to check on or flip your food. The timer will pause when the lid is open and then automatically resume after it is closed.
7. When broiling time is complete, the unit will beep and **END** will appear on the display screen. Keep the lid open after removing your food so the unit will cool down faster.
NOTE: If you need to cook your food longer, simply press the **TIME** up arrow to add more time, then press the **START/STOP** button.

Figure 7

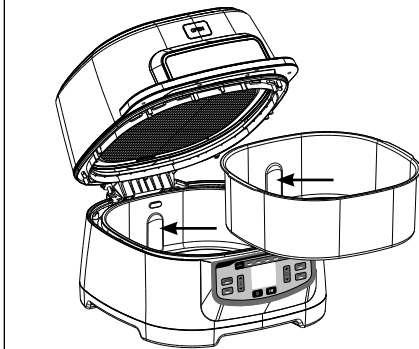

Sauté

1. Place the cooking pot in the unit aligning the rear bump on the unit with the indent on the pot. Ensure the splatter shield is in place and close the lid. (See Figure 8)
2. Press the **PRESET** button twice. The **SAUTE** indicator light illuminates. The display will show the default time (20 min) and temperature (400 °F) and
3. Use the up and down **TIME** arrows to set the cooking time and the Up and down **TEMP** arrows to adjust the temperature.
Time adjustment range: from 1 min to 60 min.
Temperature adjustment range: from 180 °F to 400 °F.
4. Press the **START/STOP** button to begin preheating. Progress bar will appear on the display screen. It can take several minutes to preheat, depending on the selected temperature setting.
5. When preheating is complete, the unit will beep and **"Add Food"** will flash across on the display screen.
6. Open the lid and place food in a oven safe dish directly in the cooking pot. Once the lid is closed, cooking will begin and the timer will start counting down.
NOTE: During the cooking process, you can open the lid to check on or flip your food. The timer will pause when the lid is open and then automatically resume after it is closed.
7. When cooking time is complete, the unit will beep and **END** will appear on the display screen. Keep the lid open after removing your food so the unit will cool down faster.
NOTE: If you need to cook your food longer, simply press the **TIME** up arrow to add more time, then press the **START/STOP** button.

Figure 8

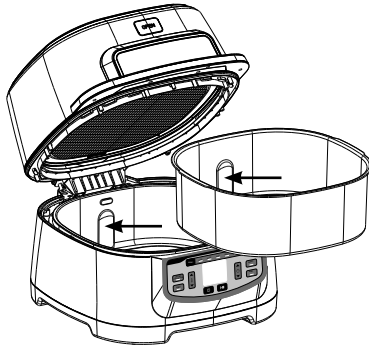

Sear

1. Place the cooking pot in the unit aligning the rear bump on the unit with the indent on the pot. Ensure the splatter shield is in place and close the lid. (See Figure 9)
2. Press the **PRESET** button three times. The **SAUTE** indicator light illuminates. The display will show the default time (10 mins) and temperature (450 °F)
3. Use the Up and down **TIME** arrows to set the cooking time and the up and down **TEMP** arrows to adjust the temperature.
Time adjustment range: from 1 min to 60 min.
Temperature adjustment range: from 180 °F to 450 °F.
4. Press the **START/STOP** button to begin preheating. Progress bar will appear on the display screen. It can take several minutes to preheat, depending on the selected temperature setting.
5. When preheating is complete, the unit will beep and **"Add Food"** will flash across on the display screen.
6. Open the lid and place food in a oven safe dish directly in the cooking pot. Once the lid is closed, cooking will begin and the timer will start counting down.
NOTE: During the cooking process, you can open the lid to check on or flip your food. The timer will pause when the lid is open and then automatically resume after it is closed.
7. When cooking time is complete, the unit will beep and **END** will appear on the display screen. Keep the lid open after removing your food so the unit will cool down faster.
NOTE: If you need to cook your food longer, simply press the **TIME** up arrow to add more time, then press the **START/STOP** button.

Figure 9

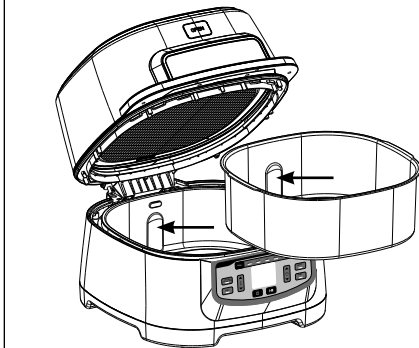

Pizza

1. The 9-in-1 AirPro XL Grill allows you to cook fresh or frozen pizza. For frozen pizza, place the cooking pot in the unit and then place the grilling plate inside the pot. For fresh pizza, insert only the cooking pot and prepare the dough on parchment paper. (See Figure 10). Pick up the fresh prepared pizza with the parchment paper and place them both in the cooking pot.
NOTE: The main unit has a rear bump that must be aligned with the indent on the pot and also with the curve on the grilling plate. Ensure the splatter shield is in place and close the lid. (See Figure 10)
2. Press the **PRESET** button four times. The **PIZZA** indicator light illuminates. The Display will show the default time (10 mins) and temperature (360 °F).
3. Use the up and down **TIME** arrows to set the cooking time and the Up and down **TEMP** arrows to adjust the temperature.
Time adjustment range: from 1 min to 60 mins.
Temperature adjustment range: from 180 °F to 450 °F.
4. Press the **START/STOP** button to begin preheating. Progress bar will appear on the display screen. It can take several minutes to preheat, depending on the selected temperature setting.

Figure 10

Frozen Pizza

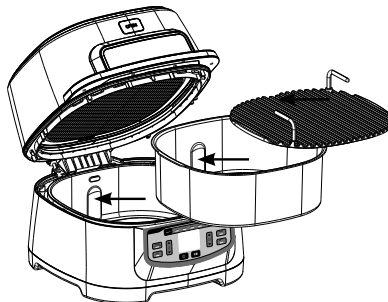

Fresh Pizza

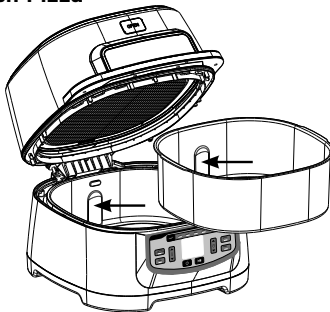

5. When preheating is complete, the unit will beep and **“Add Food”** will flash across on the display screen.
6. Open the lid. If making frozen pizza place it directly on the grilling plate. If you are making fresh pizza, prepare the dough on parchment paper. Pick up the fresh prepared pizza with the parchment paper and place them both in the cooking pot. Once the lid is closed, cooking will begin and the timer will start counting down.
NOTE: During the cooking process, you can open the lid to check on your food. The timer will pause when the lid is open and then automatically resume after it is closed.
7. When cooking time is complete, the unit will beep and **END** will appear on the display screen. Keep the lid open after removing your food so the unit will cool down faster.
NOTE: If you need to cook your food longer, simply press the **TIME** up arrow to add more time, then press the **START/STOP** button.

Dehydrate

1. Place the Cooking Pot in the unit.

NOTE: The main unit has a rear bump that must be aligned with the indent on the pot. Ensure the splatter shield is in place and close the lid. (See Figure 11)

2. Press the **PRESET** button five times until **DEHYDRATE** light illuminates. The Display will show the default time (8 hours) and temperature (130 °F).

3. Use the up and down **TEMP** arrows to adjust the temperature and the up and down **TIME** arrows to set the cooking time.

Temperature adjustment range:
from 90 °F to 180 °F.

Time adjustment range:
from 1 hour to 24 hours.

4. Press the **START/STOP** button to begin dehydration process.
5. Open the lid and place food in the cooking pot. Place the baking rack on top (to

avoid ingredients flying around the inside of the unit; due to the powerful circular heat technology). Once the lid is closed, press **START/STOP** button to start the dehydration process and timer will start counting down.

NOTE: During the dehydration process, you can open the lid to check on or flip your food. The timer will pause when the lid is open and then automatically resume after it is closed.

6. When dehydration time is complete, the unit will beep and **END** will appear on the display screen. Keep the lid open after removing your food so the unit will cool down faster.
NOTE: If you need to dehydrate longer, simply press the **TIME** up arrow to add more time, then press the **START/STOP** button.

Figure 11

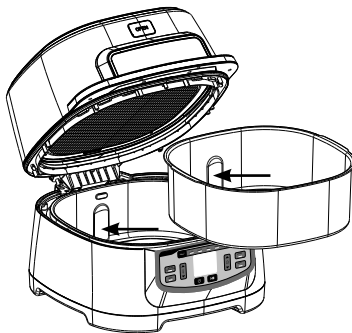

User Maintenance Instructions

This appliance requires little maintenance. It contains no user-serviceable parts. Any servicing requiring disassembly other than cleaning must be performed by a qualified appliance repair technician.

Care & Cleaning Instructions

WARNING! Allow the unit to cool fully before cleaning. The 9-in-1 AirPro XL Grill should be cleaned thoroughly after every use

1. Unplug the 9-in-1 AirPro XL Grill. Remove frying basket or grill plate and cooking pot. Make sure the accessories have cooled completely before cleaning.
2. Wash the accessories (frying basket, grill plate, cooking pot and splatter shield) in hot soapy water. Do not use metal kitchen utensils or abrasive cleansers or cleaning products as this may damage the coating.
3. The frying basket, grill plate and cooking pot are dishwasher-safe. For best results, place in the top rack of your dishwasher to clean.
4. Wipe the unit body with a soft, non-abrasive damp cloth to clean.

Storing Instructions

1. Make sure the 9-in-1 AirPro XL Grill is unplugged and all parts are clean and dry before storing.
2. Never store the unit while it is hot or wet.
3. Store the unit in its box or in a clean, dry place.

Troubleshooting charts

1. **“Add Food” appears on the control panel display.**
The unit has completed its **Grill** preheating and it is now time to add your ingredients.
2. **“Shut Lid” appears on the control panel display.**
The hood is open and needs to be closed for the selected function to start.
3. **“Add Pot” appears on the control panel display.**
The pot is not installed in the unit.

Cooking charts

GRILL

- Verify that the internal temperature follows USDA guidelines using an internal probe.

GRILL	TEMP	TIME (DEPENDING ON THICKNESS)	INT. TEMP.	ADDITIONAL INFO
Chicken Breasts boneless, skinless	500 °F	5 – 6 min per side	165 °F*	Rest, covered, 5 min
Chicken Thighs boneless, skinless	500 °F	5 – 7 min per side	165 °F*	Rest, covered, 5 min
Chicken/Turkey Burger	500 °F	3 – 5 min per side	165 °F*	Rest, covered, 5 min
Steak Sirloin 1 1/2" thick	500 °F	Rare - 7 min, flip halfway	125 °F*	Rest, covered, 5 min
		Med rare - 8 1/2 min, flip halfway	135 °F*	Rest, covered, 5 min
		Med - 10 min, flip halfway	145 °F*	Rest, covered, 5 min
		Med well - 11 min, flip halfway	150 °F*	Rest, covered, 5 min
Well - 11 1/2 min, flip halfway	160 °F*	Rest, covered, 5 min		
Beef Burger	500 °F	3 – 5 min per side	160 °F*	Rest, covered, 5 min
Pork Chops boneless 8oz	500 °F	7 – 8 min per side	145 °F*	
Sausage	500 °F	6 – 10 min, rotating often	160 °F*	Rest, covered, 5 min
Bacon	500 °F	2 – 4 min per side	-	Until desired crispness
Salmon	400 °F	3 – 4 min per side	145 °F	Serve immediately
Shrimp	500 °F	1 – 2 min per side	-	Serve immediately

* Remove the meat when 5 °F away from final cooking temperature (because of carryover cooking), allowing it to rest, covered, for 5 minutes for juicier results.

ROAST

- Verify that the internal temperature follows USDA guidelines using an internal probe.

ROAST	TEMP	TIME (DEPENDING ON THICKNESS)	INT. TEMP.	ADDITIONAL INFO
Chicken Breast bone in	400 °F	20 – 25 min	165 °F*	Rest, covered, 5 min
Chicken Thigh bone in	400 °F	20 – 25 min	165 °F*	Rest, covered, 5 min
Chicken whole	375 °F	14 min / lb (cover for half the time)	165 °F*	Rest, uncovered, 10 min
Pork Loin Roast	375 °F	16 min / lb	145 °F*	Rest, covered, 10 min
Beef Roast	350 °F	20 – 25 / lb	140 °F*	Rest, covered, 10 min

* Remove the meat when 5 °F away from final cooking temperature (because of carryover cooking), allowing it to rest for 5 or 10 minutes for juicier results.

BAKE

- **Great for ready-to-use, ready-made store bought items!**
- Always preheat the AirPro XL Grill
- TIP: reduce the temperature indicated on a packaging or a recipe by 25 °F and the time by 20%

BAKE	TEMP	TIME	ADDITIONAL INFO
Baked Potatoes	325 °F	50 min – 1 hr 15	Poke potatoes all over with a fork before wrapping in foil
Cinnamon Rolls	375 °F	11 – 14 min	Cover with foil halfway through for less brown tops if preferred
Cookies	350 °F	6 – 9 min	Less time for chewy cookies, more time for crisp cookies
Brownies	325 °F	20 – 25 min	Do not overbake - check doneness with a toothpick

AIR FRY

- For crispier results, stir ingredients often.

VEGETABLES	TEMP	TIME	VEGETABLES	TEMP	TIME
Asparagus 1 bunch, thin spears	400 °F	4 – 6 min	Broccoli Florets 3 – 4 cups	400 °F	12 – 16 min
Asparagus 1 bunch, thick spears	400 °F	6 – 7 min	Brussels Sprouts 1 lb	375 °F	9 – 12 min
Cauliflower Florets 3 – 4 cups	400 °F	11 – 14 min	Corn on the Cob 4 ears	400 °F	4 – 6 min
Eggplant 1 1/2 inch cubes (roasted)	400 °F	12 min	Carrots 2 1/2 cups, 1/2 inch pieces	400 °F	12 – 16 min
Kale (place directly in cooking pot, cover with baking rack) 3 cups, stems removed	375 °F	7 min	Mushrooms 3 cups, sliced	400 °F	8 – 10 min
Peppers, bell 1 inch chunks	375 °F	8 min	Peppers, jalapeno, pobiano (roasted)	375 °F	8 min
Pickles breaded	400 °F	4 – 7 min	Zucchini 1/4 inch discs	400 °F	10 – 14 min
Potatoes, White French Fries, (fresh, soaked, 1/4 to 1/3 inch thick)	400 °F	13 – 16 min	Root Vegetables 1/2 inch chunks (roasted)	400 °F	12 – 16 min
Potatoes, White 1 inch cubes	400 °F	10 – 12 min	Potatoes, White whole, 6 – 8 oz, pierced with a fork	400 °F	32 min
Potatoes, White wedges	400 °F	16 – 20 min	Potatoes, Sweet whole, 6 – 8 oz, pierced with a fork	375 °F	24 – 28 min

BEEF	TEMP	TIME	BEEF	TEMP	TIME
Hamburgers 1/4 lb (up to 4)	360 °F	12 – 16 min	Steaks 2 (8 oz) steaks	360 °F	8 – 12 min
Hot Dogs / Sausages	360 °F	10 – 15 min	Beef Tenderloin 1 lb, rare	360 °F	16 min
Meatloaf 1 lb	360 °F	35 – 40 min	Beef Tenderloin 1 lb, medium	360 °F	18 min

CHICKEN	TEMP	TIME	CHICKEN	TEMP	TIME
Chicken Breast boneless, skinless	360 °F	15 – 16 min	Chicken Tenders/Fingers battered	360 °F	11 – 13 min
Chicken Thighs 6 – 8 oz ea., boneless	360 °F	16 – 18 min	Chicken Wings 2 lbs	400 °F	17 – 22 min

PORK AND LAMB	TEMP	TIME	PORK AND LAMB	TEMP	TIME
Bacon thick cut, up to 1 lb	400 °F	6 – 8 min	Pork Chops 1 inch thick	375 °F	8 – 11 min
Ham precooked, boneless, 3 lbs	300 °F	50 min	Pork Chops 2 inch thick (10 – 12 oz)	375 °F	12 – 15 min
Lamb Loin Chops 1 inch thick	400 °F	6 – 10 min			

FISH AND SEAFOOD	TEMP	TIME	FISH AND SEAFOOD	TEMP	TIME
Shrimp thawed, battered	325 °F	9 min	Shrimp thawed, sauced	325 °F	4 – 6 min
Catfish Fingers thawed, battered	400 °F	8 – 12 min	Salmon filets thawed, 2	400 °F	7 – 10 min

FROZEN FOODS*	TEMP	TIME	FROZEN FOODS*	TEMP	TIME
Cheese Sticks	350 °F	5 – 7 min	Fish Sticks	400 °F	10 – 14 min
Chicken Nuggets 12 oz box	360 °F	8 – 12 min	Meatballs 1 inch, pre-cooked	375 °F	6 – 7 min
French Fries thick 2 cups	400 °F	14 – 17 min	Onion Rings	360 °F	10 – 13 min
French Fries thin 2 cups	400 °F	12 – 14 min	Pizza 7 inch x 8 inch	360 °F	10 – 12 min

* All items are to be air fried from frozen (do not thaw).

DESSERTS	TEMP	TIME	DESSERTS	TEMP	TIME
Apple Turnovers	400 °F	8 min	Donuts	350 °F	6 – 7 min
Cake	350 °F	20 – 28 min			

DEHYDRATE

- Position the herbs whole, on their stems, into the cooking pot
- Cover with the baking rack.
- Turn several times during DEHYDRATE for even drying.

HERB	TEMP	TIME	HERB	TEMP	TIME
Kale Chips , stems removed	135 °F	1 1/2 – 3 hrs	Rosemary	135 °F	1 1/2 – 3 hrs
			Sage	135 °F	1 1/2 – 3 hrs
Oregano	135 °F	1 1/2 – 3 hrs	Tarragon	135 °F	2 1/2 – 3 hrs
Parsley	135 °F	1 1/2 – 3 hrs	Thyme	135 °F	2 1/2 – 3 hrs

FRUIT / VEGETABLES

- Wash all fruit skins well.
- Slice fruit into 1/4 inch thick slices
- Arrange directly into the cooking pot with space between each slice to ensure even drying.
- Cover with the baking rack.
- Rotate foods halfway through DEHYDRATE time for even drying.

DEHYDRATE	TEMP	TIME	
Apples rounds	135 °F	6 – 7 hrs	Core/slice into 1/4 inch slices
Kiwi	135 °F	5 hrs	1/4 inch rounds
Mango/Papaya pieces	135 °F	6 – 8 hrs	Peel/slice into 1/4 inch slices
Orange Slices fully dried	135 °F	8 hrs	Citrus is crisp when fully dried
Tomatoes, Roma	150 °F	6 – 7 hrs	Skin side down
Tomatoes, Cherry/Grape	150 °F	4 – 7 hrs	Skin side down

DEHYDRATE	TEMP	TIME	
Beef Jerky	150 °F	4 – 5 hrs	1/2 lb London Broil or Flank
Chickpeas seasoned	160 °F	8 – 10 hrs	Canned, rinsed

Limited Two-Year Warranty

SENSIO Inc. hereby warrants that for a period of **TWO YEARS** from the date of purchase, this product will be free from mechanical defects in material and workmanship, and for 90 days in respect to non-mechanical parts. At its sole discretion, SENSIO Inc. will either repair or replace the product found to be defective, or issue a refund on the product during the warranty period.

Exclusions:

The warranty does not cover normal wear of parts or damage resulting from any of the following: negligent use of the product, use of improper voltage or current, improper routine maintenance, use contrary to the operating instructions, disassembly, repair, or alteration by anyone other than qualified SENSIO Inc. personnel. Also, the warranty does not cover Acts of God such as fire, floods, hurricanes, or tornadoes.

SENSIO Inc. shall not be liable for any incidental or consequential damages caused by the breach of any express or implied warranty. Apart from the extent prohibited by applicable law, any implied warranty of merchantability or

The warranty is only valid for the original retail purchaser from the date of initial retail purchase and is not transferable. Keep the original sales receipt, as proof of purchase is required to obtain warranty validation. Retail stores selling this product do not have the right to alter, modify, or in any way revise the terms and conditions of the warranty.

fitness for a particular purpose is limited in time to the duration of the warranty. Some states, provinces or jurisdictions do not allow the exclusion or limitation of incidental or consequential damages, or limitations on how long an implied warranty lasts, and therefore, the above exclusions or limitations may not apply to you. The warranty covers specific legal rights which may vary by state, province and/or jurisdiction.

How To Obtain Warranty Service:

You must contact Customer Service at our toll-free number: 1-866-832-4843. A Customer Service Representative will attempt to resolve warranty issues over the phone. If the Customer Service Representative is unable to resolve the problem, you will be provided with a case number and asked to return the product to SENSIO Inc. Attach a tag to the product that includes: your name, address, daytime contact telephone number, case number, and description of the problem.

Also, include a copy of the original sales receipt. Carefully package the tagged product with the sales receipt, and send it (with shipping and insurance prepaid) to SENSIO Inc.'s address. SENSIO Inc. shall bear no responsibility or liability for the returned product while in transit to SENSIO Inc.'s Customer Service Center.



For customer service questions or comments
1-866-832-4843
bellahousewares.com

Sensio Inc.
New York, NY 10016/USA

90100 R9