

DT1103-SN/DT1103-BLK

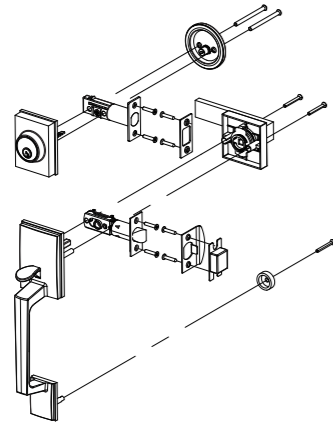

NEED HELP? CONTACT US!

Have product questions? Need technical support?
Please feel free to contact us:
Technical Support and E-Warranty Certificate
www.vevor.com/support

This is the original instruction, please read all manual instructions carefully before operating. VEVOR reserves clear interpretation of our user manual. The appearance of the product shall be subject to the product you received. Please forgive us that we won't inform you again if there is any technology or software updates on our product.

01

INSTALLATION INSTRUCTIONS FOR GRIP SET

IMPORTANT

1. Use the components from this package. Make no substitutions.
2. Consult local building codes for requirements in your area.
3. Before starting, read all instructions and lay out all parts as shown.

PASSAGE LATCH BACKSET

2 Latches provided: 1 x 2-3/8" (60 mm) and 1 x 2-3/4" (70 mm)

Select the appropriate latch according to the distance from the door hole to the edge of the door.

DEADBOLT LATCH ADJUSTMENT



2-3/8" Position:
Rotate counter clock-wise and push to 2-3/8" (60 mm) position.

2-3/4" Position:
Rotate clockwise and pull to 2-3/4" (70 mm) position.

02

1. DOOR PREP.

FOR REPLACEMENT INSTALLATION:

Remove all old lock components. Use the template verify door preparation and make any necessary modifications.

FOR NEW INSTALLATION:

Follow the instructions on the template.

2. LATCH INSTALLATION

FACE PLATE

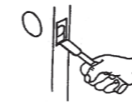

DEADBOLT IS PLACED IN UPPER HOLE; THE LATCH IS PLACED IN THE LOWER HOLE.

Keeping edges parallel to the face of the door, outline both face plates & remove deadbolt & latch from the door edge.

Chisel the outline of each face plate until it is flush with the door edge, 5/32" (4 mm) deep.

Insert deadbolt in upper edge hole. The hub must be down, and the bolt must be extended. Secure with two wood screws.

Insert latch in the lower hole with the bevel facing jamb and secure with two wood screws.

NOTE:



HUB FOUILLOT
Install faceplate deadbolt with hub down and bolt extended. Lower latch bolt bevel must face the door jamb.

03

3. TRIM INSTALLATION

UPPER TRIM:

Place the outer trim against the outside of the door. Tailpiece(s) must fit through the hub of the deadbolt in vertical position.

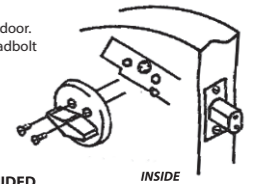

Attach the inner trim with a 25"(64mm) machine and tighten it securely.

NOTE: IF TAMPER PROOF SCREW IS INCLUDED, VERIFY THE PROPER FUNCTION OF THE LOCK BEFORE INSTALLING TAMPER PROOF SCREW.

LOWER TRIM:

Place the handle set against the outside of the door. The spindle should be inserted through the hub of the latch. Attach the inner knob to handle set posts with either the 1"(25 mm) or 1.5"(39 mm) trim screws depending on the width of your door.

Attach the bottom of the exterior handle to the door with a wood screw or captive screw for a metal door at the same backset as a latch.

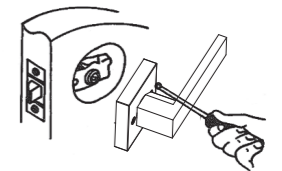

Attach the inner knob with 1" (25 mm) or 1.5" (39 mm) screws at 12:00 and 6:00 o'clock.

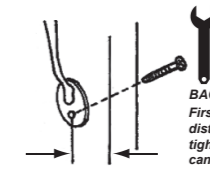

BACKSET

First, loosen the screw tube and adjust the distance accordingly. Then, use a wrench to tighten the screw tube. After this process can be continued for installation.

04

4. STRIKE INSTALLATION

UPPER STRIKE:

- 1 Smear coloring on the dimple of the bolt. Retract the bolt and close the door. Extend the bolt, leaving a mark on the door jamb.
- 2 Drill a 1"(25.4mm) diameter hole, 1-1/4" (29 mm) deep, in the door frame centered on the mark made from 1.
- 3 Center strike over hole & trace around strike. Chisel out the door frame until the strike is flush.
- 4 FOR SECURITY STRIKE: Position strike with large holes toward the door stop. Pre-drill large holes 3" (76 mm) deep. Attach wood screws in smaller holes.

SECURITY STRIKE

OTHER STRIKES

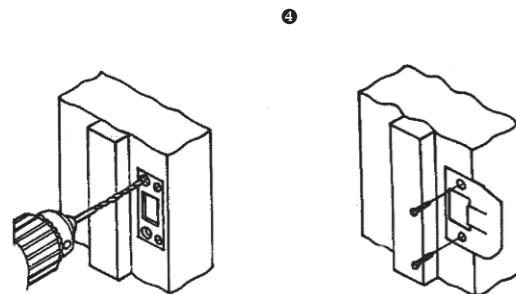

05

LOWER STRIKE:

- 1 Partially close the door. Mark a horizontal line on the door frame at the height of the center of the latch bolt.
- 2 Measure from the door face (jamb side) to the center of a latch.
- 3 Mark a vertical line on the frame at dimension from 2.
- 4 Where the lines meet, bore a 1" (25.4 mm) diameter hole 5/8" (16 mm) deep.
- 5 Center strike screw holes on the vertical center line and outline strike.
- 6 Chisel out the wood so the strike is flush with the frame.
- 7 Install with two wood screws.

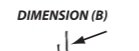

VERTICAL LINE

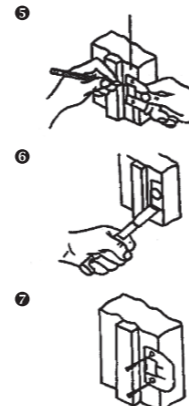

06



TEMPLATE FOR GRIPSET INSTALLATION

