

# NETGEAR®

## User Manual

---

### Nighthawk Tri-band Mesh WiFi 6 System

#### Models:

Tri-band Mesh WiFi 6 Router Model MR80

Tri-band Mesh WiFi 6 Satellite Model MS80

May 2022  
202-12138-02

#### **NETGEAR, Inc.**

350 E. Plumeria Drive  
San Jose, CA 95134, USA

### **Support and Community**

Visit [netgear.com/support](https://www.netgear.com/support) to get your questions answered and access the latest downloads.

You can also check out our NETGEAR Community for helpful advice at [community.netgear.com](https://community.netgear.com).

### **Regulatory and Legal**

Si ce produit est vendu au Canada, vous pouvez accéder à ce document en français canadien à <https://www.netgear.com/support/download/>.

(If this product is sold in Canada, you can access this document in Canadian French at <https://www.netgear.com/support/download/>.)

For regulatory compliance information including the EU Declaration of Conformity, visit <https://www.netgear.com/about/regulatory/>.

See the regulatory compliance document before connecting the power supply.

For NETGEAR's Privacy Policy, visit <https://www.netgear.com/about/privacy-policy>.

By using this device, you are agreeing to NETGEAR's Terms and Conditions at <https://www.netgear.com/about/terms-and-conditions>. If you do not agree, return the device to your place of purchase within your return period.

Do not use this device outdoors.

Applicable to 6 GHz devices only: Only use the device indoors. The operation of 6 GHz devices is prohibited on oil platforms, cars, trains, boats, and aircraft, except that operation of this device is permitted in large aircraft while flying above 10,000 feet. Operation of transmitters in the 5.925-7.125 GHz band is prohibited for control of or communications with unmanned aircraft systems.

### **Trademarks**

Trademarks© NETGEAR, Inc., NETGEAR, and the NETGEAR Logo are trademarks of NETGEAR, Inc. Any non-NETGEAR trademarks are used for reference purposes only.

# Contents

## Chapter 1 Overview

- Router hardware and LED overview.....9
  - Router hardware features.....9
  - Router LED behavior.....10
- Satellite hardware and LED overview.....11
  - Satellite hardware features.....11
  - Satellite LED behavior.....12
- Router and satellite labels.....12
- Connect your router.....13
- Place your satellite.....14
- Sync your satellite with your router.....14

## Chapter 2 Connect to the Network and Access the Router

- Connect to the network.....17
  - Connect to the network using a wired connection.....17
  - Find and connect to the WiFi network.....17
  - WiFi connection using WPS.....17
- Types of logins.....18
- Use a web browser to access the router.....18
  - Automatic Internet Setup.....18
  - Log in to the router.....20
- Install and manage your mesh system with the Nighthawk app...20
- Change the language.....21

## Chapter 3 Specify Your Internet Settings

- Use the Internet Setup Wizard.....23
- Manually set up the Internet connection.....23
  - Specify an Internet connection without a login.....23
  - Specify an Internet connection that uses a login.....25
- Specify IPv6 Internet connections.....26
  - Requirements for entering IPv6 addresses.....27
  - Use auto detect for an IPv6 Internet connection.....27
  - Set up an IPv6 6to4 tunnel Internet connection.....28
  - Set up an IPv6 pass-through Internet connection.....30
  - Set up an IPv6 fixed Internet connection.....30
  - Set up an IPv6 DHCP Internet connection.....31



- Set up an IPv6 PPPoE Internet connection.....33
- Use auto config for an IPv6 Internet connection.....35
- Set up an IPv6 6rd Internet connection.....36
- Manage the MTU size.....38
  - MTU concepts.....38
  - Change the MTU size.....39

**Chapter 4 Control Access to the Internet**

- Activate and manage NETGEAR Armor using the Nighthawk app.....42
- Network access control list.....42
  - Enable the network access control list, set the access rule, and allow or block connected devices.....43
  - Manage allowed devices currently not on the network.....45
  - Manage blocked devices currently not on the network.....46
- Use keywords to block Internet sites.....48
- Block services from the Internet.....49
- Delete keywords from the blocked list.....51
- Prevent blocking on a trusted computer.....51
- Schedule when to block Internet sites and services.....52
- Set up security event email notifications.....53

**Chapter 5 Optimize Performance**

- Use Dynamic QoS to optimize Internet traffic management.....56
  - Enable Dynamic QoS.....56
  - Enable or disable the automatic QoS database update.....57
  - Manually update the dynamic QoS database.....57
- Improve network connections with Universal Plug and Play.....58

**Chapter 6 Manage WiFi Settings**

- Change the WiFi password or the WiFi security.....61
- Add a WiFi network.....62
- Set up a guest WiFi network.....63
- Use the WPS wizard for WiFi connections.....65
- Enable or disable 20/40 MHz coexistence for the 2.4 GHz radio.....66
- Hide your mesh network’s SSID.....67
- Generate a new backhaul password.....68
- Enable or disable implicit beamforming.....68
- Enable or disable AX WiFi.....69
- Change the region of operation.....70
- Change the CTS/RTS threshold or preamble mode for a radio....71

**Chapter 7 Manage Network Settings**

- View or change the WAN settings.....74



## Nighthawk Tri-band Mesh WiFi 6

Set up a default DMZ server.....	75
Change the router's device name.....	76
Change the LAN IP address settings.....	76
Specify the IP addresses that the router assigns.....	78
Disable the DHCP server feature in the router.....	79
Manage reserved LAN IP addresses.....	80
Reserve an IP address.....	80
Edit a reserved IP address.....	81
Delete a reserved IP address entry.....	81
Set the time zone manually.....	82
Change the NTP server.....	82
Set up the router as a WiFi access point.....	83
Set up a bridge for a port group or VLAN tag group.....	84
Set up a bridge for a port group.....	84
Set up a bridge for a VLAN tag group.....	85
Set up an IPTV port.....	86
Manage custom static routes.....	87
Set up a static route.....	88
Edit a static route.....	89
Delete a static route.....	90

### Chapter 8 Manage your Router and Satellite

Update the router and satellite firmware.....	92
Check for new firmware and update the router and satellite...92	
Manually update the firmware.....	93
Manually update satellite firmware.....	93
Manually update router firmware.....	94
Manage the firmware update settings.....	95
Change the admin password.....	95
Enable admin password reset.....	96
Reset the admin password.....	97
Always use HTTPS to access the router.....	98
View information about the router, the Internet port, and WiFi settings.....	99
Display the statistics of the Internet port.....	99
Check the Internet connection status.....	101
View and manage logs of router activity.....	102
View devices currently on the mesh network.....	103
View the satellite status in the satellite web interface.....	104
Monitor Internet traffic.....	105
Set up and manage Dynamic DNS.....	106
Set up a new Dynamic DNS account.....	107
Use a DNS account that you already created.....	107
Change the Dynamic DNS settings.....	108

- Manage the router configuration file.....109
  - Back up the settings.....109
  - Erase the settings on the router.....110
  - Restore the settings.....110
- Return the router or satellite to its factory default settings.....111
  - Use the Reset button.....111
  - Erase the settings on the router.....112
- Connect to your router with Anywhere Access.....112

**Chapter 9 Use OpenVPN to Access Your Network**

- About VPN connections.....115
- Enable OpenVPN service in the router.....116
- Install OpenVPN software on a VPN client.....117
  - Install OpenVPN software on a Windows-based computer...117
  - Install OpenVPN software on a Mac computer.....119
  - Install OpenVPN software on an iOS device.....120
  - Install OpenVPN software on an Android device.....121
- LAN IP addressing in VPN networks.....122
- Use VPN to access your Internet service at home.....122
  - Allow VPN client Internet access in the router.....122
  - Block VPN client Internet access in the router.....123

**Chapter 10 Manage Port Forwarding and Port Triggering**

- Manage port forwarding to a local server.....126
  - Set up port forwarding to a local server.....126
  - Add a custom port forwarding service.....127
  - Change a port forwarding service.....128
  - Delete a port forwarding entry.....129
  - Application example: Make a local web server public.....129
  - How the router implements the port forwarding rule.....130
- Port triggering.....130
  - Add a port triggering service.....131
  - Enable port triggering.....132
  - Application example: Port triggering for Internet Relay Chat.132

**Chapter 11 Troubleshooting**

- Quick tips.....135
  - Sequence to restart your network.....135
  - WiFi settings.....135
  - Network settings.....135
- The router and satellite do not sync.....135
- Cannot log in to the router.....136
- Cannot access the Internet.....137
- Troubleshoot Internet browsing.....138



Troubleshoot PPPoE.....139  
Troubleshoot WiFi connectivity.....139  
Troubleshoot your network using the ping utility.....140  
    Test the LAN path from a Windows-based computer to your  
    router.....140  
    Test the path from a Windows-based computer to a remote  
    device.....141

**Chapter 12 Supplemental Information**

Factory settings.....144  
    Factory settings for router model MR80.....144  
    Factory settings for satellite model MS80.....145  
Technical specifications.....147  
    Technical specifications for router model MR80.....147  
    Technical specifications for satellite model MS80.....148



# 1

## Overview

---

The Tri-band Mesh WiFi 6 Router (model MR80) connects to your modem or gateway. The Tri-band Mesh WiFi 6 Satellite (model MS80) connects to the Tri-band Mesh WiFi 6 Router and extends the WiFi signal throughout your home.

This manual describes how to manage your Tri-band Mesh WiFi 6 router and satellite from your router web interface.

**Note:** You can manage your satellite from the router web interface.

This chapter contains the following sections:

- [Router hardware and LED overview](#)
- [Satellite hardware and LED overview](#)
- [Router and satellite labels](#)
- [Connect your router](#)
- [Place your satellite](#)
- [Sync your satellite with your router](#)

For more information about the topics covered in this manual, visit the support website at <https://www.netgear.com/support/>.

**Note:** This manual refers to the Tri-band Mesh WiFi 6 Router (model MR80) as the *router*, and Tri-band Mesh WiFi 6 Satellite (model MS80) as the *satellite*.

# Router hardware and LED overview

The following sections are an overview of the router hardware features and LED behavior.

## Router hardware features

The following figure shows the router hardware features.

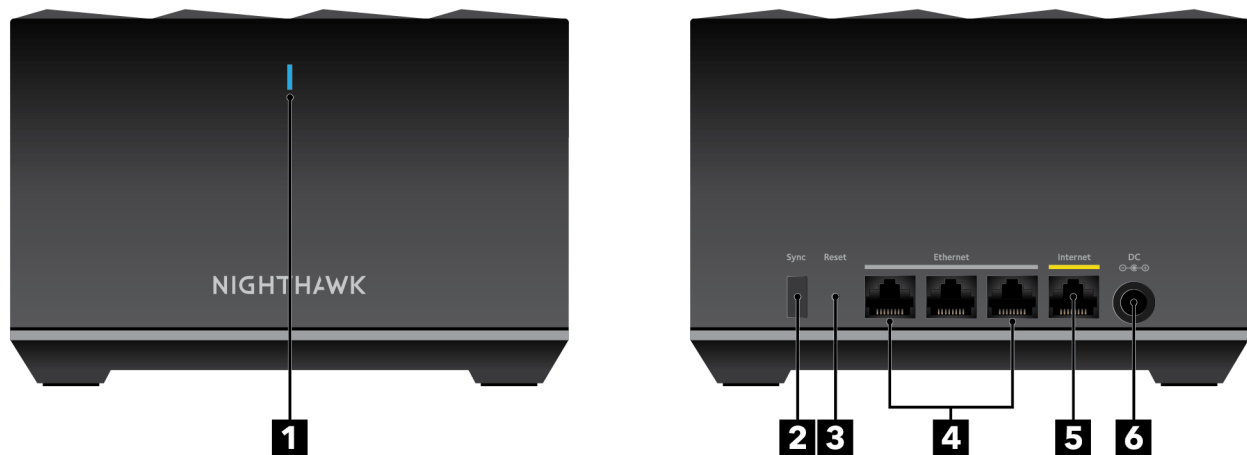

Figure 1. Router front and back views

1. Router LED
2. Sync button
3. Reset button
4. Ethernet ports
5. Internet port
6. Power connector

## Router LED behavior

The following table describes the LED behavior for the LED that is on the front of the router.

Table 1. Router LED behavior

LED color	Description
Blinking white	The router LED blinks white for one of the following reasons: <ul style="list-style-type: none"><li>• You connected the power adapter to the router. Now the router is booting and attempting to sync with the satellite.</li><li>• You pressed the <b>Sync</b> button and the router is attempting to sync with the satellite.</li><li>• You pressed the <b>Reset</b> button and the router is resetting to its factory default settings.</li></ul>
Solid blue	The router finished booting, is connected to the Internet, and is working normally. The LED stays lit solid blue when the satellite is working normally.
Solid amber	The router is unable to connect to the Internet.
Blinking amber	The router's firmware is corrupted.

# Satellite hardware and LED overview

The following sections are an overview of the satellite hardware features and LED behavior.

## Satellite hardware features

The following figures shows the satellite hardware features.

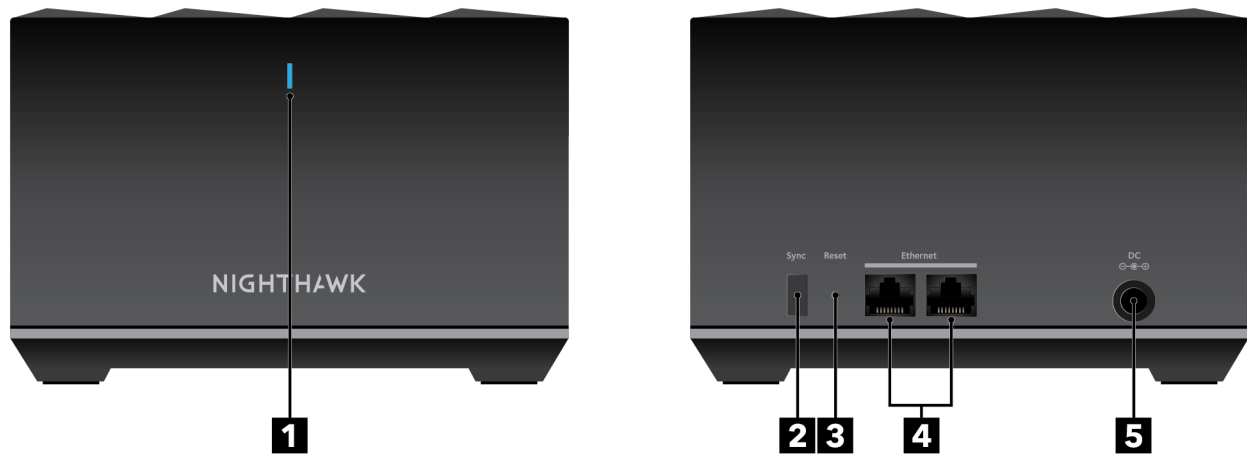

Figure 2. Satellite front and back views

1. Satellite LED
2. Sync button
3. Reset button
4. Ethernet ports
5. Power connector

## Satellite LED behavior

The following table describes the LED behavior for the LED that is on the front of the satellite.

Table 2. Satellite LED behavior

LED color	Description
Blinking white	The satellite LED blinks white for one of the following reasons: <ul style="list-style-type: none"> <li>You connected the power adapter to the satellite. Now the satellite is booting and attempting to sync with the router.</li> <li>You pressed the <b>Sync</b> button and the satellite is attempting to sync with the router.</li> <li>You pressed the <b>Reset</b> button and the satellite is resetting to its factory default settings.</li> </ul>
Solid blue	The satellite finished booting, is synced with the router, and is working normally. The LED stays lit solid blue when the satellite is working normally.
Solid amber	The satellite failed to sync with the router. Move your satellite closer to the router (or closer to your other satellite if you have more than one satellite).
Blinking red	The satellite's firmware is corrupted.

## Router and satellite labels

The router label shows the login information, the router WiFi network name and password, the router's MAC address, and the router's serial number. The following is an example of what the router label might look like:

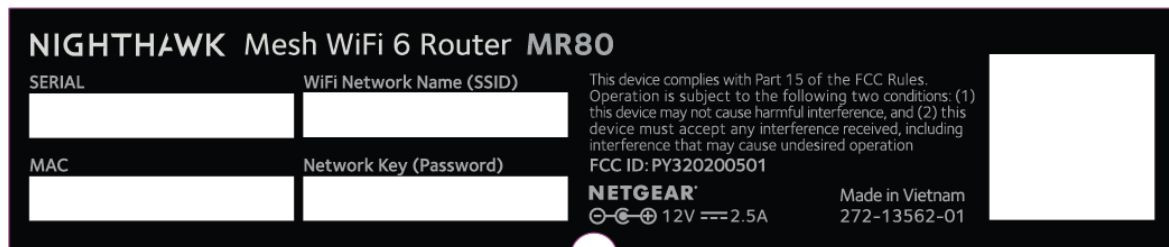

Figure 3. Router label

The satellite label also displays the WiFi network name and password, the satellite's MAC address, and the satellite's serial number. The following is an example of what the satellite label might look like:

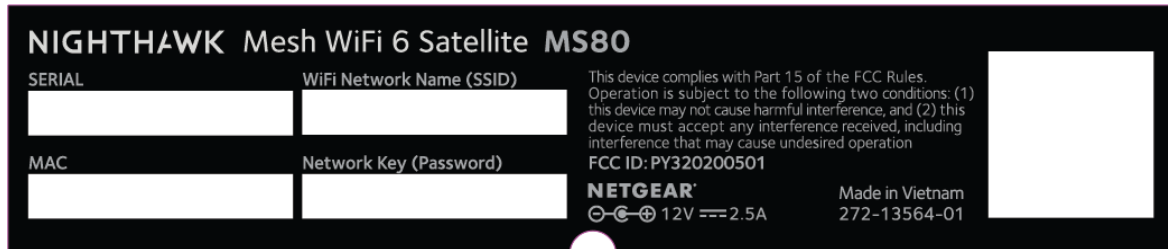

Figure 4. Satellite label

## Connect your router

Power on your router and connect it to a modem.



Figure 5. Connect your router

### To connect your router:

1. Unplug your modem's power, leaving the modem connected to the wall jack for your Internet service.  
If your modem uses a battery backup, remove the battery.
2. Plug in and turn on your modem.  
If your modem uses a battery backup, put the battery back in.
3. Connect your modem to the Internet port of your router with the Ethernet cable that came with your router.
4. Connect the power adapter to your router and plug the power adapter into an outlet.

5. If the Router LED does not light, make sure that the power adapter is properly connected to your router and power outlet.

# Place your satellite

Your satellite must be within range of your router's WiFi signal in order for it to sync with your router. Use your satellite's LED to help you determine where to place your satellite.

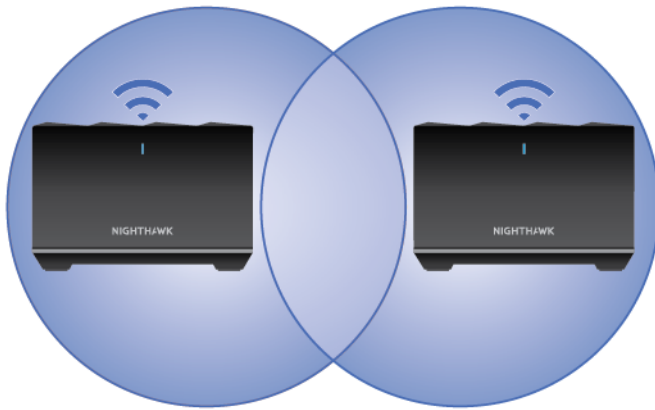

Figure 6. Place your satellite

If you own more than one satellite, your satellites can sync with each other or with your router. Place your satellites so that they are within range of each other or the router. However, at least one satellite must be within range of your router.

# Sync your satellite with your router

The satellite that comes with your router is preset to automatically find and sync to your router's WiFi signal.

### To sync your satellite:

1. Place your satellite.  
For more information, see [Place your satellite](#) on page 14.
2. Connect the satellite to a power source.  
The satellite LED blinks white. The satellite automatically finds the router's WiFi signal and attempts to sync to the router.

The satellite LED then lights one of the following colors:

- **Blue.** The router and satellite successfully synced, and the connection between the router and satellite is good.
  - **Amber.** The router and satellite failed to sync. Move the satellite closer to the router and try again.
3. If the satellite LED is amber, do the following:
    - a. Unplug your satellite, move the satellite closer to the router, and plug it back in.
    - b. Press the **Sync** button on the back of the router.
    - c. Within two minutes, press the **Sync** button on the back of the satellite.  
The satellite attempts to sync to the router. The satellite LED lights blue or amber as described in Step 2 of this procedure.
  4. If you own more than one satellite, repeat these steps to sync your other satellite.

# 2

## Connect to the Network and Access the Router

---

You can connect to the router's WiFi networks or use a wired Ethernet connection. This chapter explains the ways you can connect and how to access the router and log in.

The chapter contains the following sections:

- [Connect to the network](#)
- [Types of logins](#)
- [Use a web browser to access the router](#)
- [Install and manage your mesh system with the Nighthawk app](#)
- [Change the language](#)

# Connect to the network

You can connect to the router's network through a wired or WiFi connection. If you set up your computer to use a static IP address, change the settings so that it uses Dynamic Host Configuration Protocol (DHCP).

## Connect to the network using a wired connection

You can connect your computer to the router using an Ethernet cable and join the router's local area network (LAN).

### **To connect your computer to the router with an Ethernet cable:**

1. Make sure that the router is receiving power (its Router LED is lit).
2. Connect an Ethernet cable to an Ethernet port on your computer.
3. Connect the other end of the Ethernet cable to the Ethernet port on the router.  
Your computer connects to the local area network (LAN).

## Find and connect to the WiFi network

### **To find and select the WiFi network:**

1. Make sure that the router is receiving power (its Router LED is lit).
2. On your computer or WiFi device, find and select the WiFi network.  
The WiFi network name is on the router label.
3. Join the WiFi network and enter the WiFi password.  
The password is on the router label.  
Your device connects to the WiFi network.

## WiFi connection using WPS

You can connect your WPS-enabled device to the router's WiFi network with Wi-Fi Protected Setup (WPS) or you can find and select the WiFi network.

### **To use WPS to connect to the WiFi network:**

1. Make sure that the router is receiving power (its Router LED is lit).
2. Check the WPS instructions for your WPS-enabled device.
3. Press the **Sync** button on the router.

4. Within two minutes, on your WPS-enabled device, press its **WPS** button or follow its instructions for WPS connections.

Your WPS-enabled device connects to the WiFi network.

## Types of logins

Separate types of logins serve different purposes. It is important that you understand the differences so that you know which login to use when.

Several types of logins are associated with the router:

- **ISP login.** The login that your Internet service provider (ISP) gave you logs you in to your Internet service. Your ISP gave you this login information in a letter or some other way. If you cannot find this login information, contact your ISP.
- **WiFi network key, WiFi passphrase, or WiFi password.** Your router is preset with a unique WiFi network name (SSID) and password for WiFi access. This information is on the router label.
- **NETGEAR account login.** The free NETGEAR account that you need to register your router and manage your subscriptions. If you do not own a NETGEAR account, you can create one.
- **Router login.** The router login password that you need to log in to the router with the admin user name when you use a web browser to access the router.

## Use a web browser to access the router

When you connect to the network (either with WiFi or with an Ethernet cable), you can use a web browser to access the router to view or change its settings. When you access the router, the software automatically checks to see if your router can connect to your Internet service.

### Automatic Internet Setup

You can set up your router automatically, or you can use a web browser to access the router and set up your router manually. Before you start the setup process, get your ISP information and make sure that the computers and devices in the network are using the settings described here.

When your Internet service starts, your Internet service provider (ISP) typically gives you all the information needed to connect to the Internet. For DSL service, you might need the following information to set up your router:

- The ISP configuration information for your DSL account
- ISP login name and password
- Fixed or static IP address setting (special deployment by ISP; this setting is rare)

If you cannot locate this information, ask your ISP to provide it. When your Internet connection is working, you no longer need to launch the ISP login program on your computer to access the Internet. When you start an Internet application, your router automatically logs you in.

The NETGEAR installation assistant runs on any device with a web browser. Installation and basic setup takes about 15 minutes to complete.

### To automatically set up your router:

1. Make sure that the router is powered on.
2. Make sure that your computer or mobile device is connected to the router with an Ethernet cable (wired) or over WiFi with the preset security settings listed on the label.

**Note:** If you want to change the router's WiFi settings, use a wired connection to avoid being disconnected when the new WiFi settings take effect.

3. Launch a web browser.

The page that displays depends on whether you accessed the router before:

- The first time you set up the Internet connection for your router, the browser goes to **<http://www.routerlogin.net>** and the Configuring the Internet Connection page displays.
- If you already set up the Internet connection, enter **<http://www.routerlogin.net>** in the address field for your browser to start the installation process.

4. Follow the onscreen instructions.

The router connects to the Internet.

5. If the browser does not display the NETGEAR installation assistant, do the following:

- Make sure that the computer is connected to an Ethernet port on the router or satellite or to the mesh WiFi network.
- Make sure that the router is receiving power and that its Router LED is lit.
- Close and reopen the browser or clear the browser cache.
- Browse to **<http://www.routerlogin.net>**.

- If the computer is set to a static or fixed IP address (this setting is uncommon), change it to obtain an IP address automatically from the router.
6. If the router does not connect to the Internet, do the following:
    - a. Review your settings. Make sure that you selected the correct options and typed everything correctly.
    - b. Contact your ISP to verify that you are using the correct configuration information.
    - c. Read [Troubleshooting](#) on page 134.  
If problems persist, register your NETGEAR product and contact NETGEAR Technical Support.

## Log in to the router

When you first connect to your router and launch a web browser, the browser automatically displays the router web interface. If you want to view or change settings for the router later, you can use a browser to log in to the router web interface.

### To log in to the router:

1. Launch a web browser from a computer or mobile device that is connected to the router network.
2. Enter **<http://www.routerlogin.net>**.

**Note:** You can also enter **<http://www.routerlogin.com>** or **<http://192.168.1.1>**. The procedures in this manual use **<http://www.routerlogin.net>**.

A login window opens.

3. Enter the router admin user name and password.  
The user name is **admin**. The password is the one that you specified the first time that you logged in. The user name and password are case-sensitive.  
The BASIC Home page displays.

## Install and manage your mesh system with the Nighthawk app

With the Nighthawk app, you can easily install and manage your mesh system. The app automatically syncs any satellites that are nearby, updates your mesh system to the latest

firmware, allows you to personalize your WiFi network, and even helps register your mesh system with NETGEAR.

The Nighthawk app is available for iOS and Android mobile devices.

**Note:** If you own any satellites, make sure they are powered on before installing your mesh system with the Nighthawk app.

### To install your mesh system using the Nighthawk app:

1. To download the app, visit [Nighthawk-app.com](http://Nighthawk-app.com).
2. On your mobile device, tap **Settings > Wi-Fi** and find and connect to your router's WiFi network.  
Your router's WiFi network name (SSID) and network key (WiFi password) are on the router label.  
If the label includes a QR code, you can scan the QR code to join the router's WiFi network.
3. Launch the Nighthawk app on your mobile device.
4. Follow the prompts on the app to install your mesh system and connect to the Internet.

## Change the language

By default, the language that displays when you log in to the router web interface is set to Auto.

### To change the language:

1. Launch a web browser from a computer or mobile device that is connected to the router network.
2. Enter **http://www.routerlogin.net**.  
A login window opens.
3. Enter the router admin user name and password.  
The user name is **admin**. The password is the one that you specified the first time that you logged in. The user name and password are case-sensitive.  
The BASIC Home page displays.
4. In the upper right corner, select a language from the menu.
5. When prompted, click the **OK** button to confirm this change.  
The page refreshes with the language that you selected.

# 3

## Specify Your Internet Settings

---

Usually, the quickest way to set up the router to use your Internet connection is to allow your router to detect the Internet connection automatically when you first access the router web interface. You can also customize and manually specify your Internet settings.

This chapter contains the following sections:

- [Use the Internet Setup Wizard](#)
- [Manually set up the Internet connection](#)
- [Specify IPv6 Internet connections](#)
- [Manage the MTU size](#)

# Use the Internet Setup Wizard

You can use the Setup Wizard to detect your Internet settings and automatically set up your router. The Setup Wizard is not the same as the pages that display the first time you connect to your router to set it up.

## To use the Setup Wizard:

1. Launch a web browser from a computer or mobile device that is connected to your mesh network.
2. Enter **http://www.routerlogin.net**.  
A login window opens.
3. Enter the router admin user name and password.  
The user name is **admin**. The password is the one that you specified the first time that you logged in. The user name and password are case-sensitive.  
The BASIC Home page displays.
4. Select **ADVANCED > Setup Wizard**.  
The Setup Wizard page displays.
5. Select the **Yes** radio button.  
If you select the **No** radio button, you are taken to the Internet Setup page (see [Manually set up the Internet connection](#) on page 23).
6. Click the **Next** button.  
The Setup Wizard searches your Internet connection for servers and protocols to determine your Internet configuration.

# Manually set up the Internet connection

You can view or change the router's Internet connection settings.

## Specify an Internet connection without a login

### To specify the Internet connection settings:

1. Launch a web browser from a computer or mobile device that is connected to your mesh network.
2. Enter **http://www.routerlogin.net**.  
A login window opens.

3. Enter the router admin user name and password.  
The user name is **admin**. The password is the one that you specified the first time that you logged in. The user name and password are case-sensitive.  
The BASIC Home page displays.
4. Select **Internet**.  
The Internet Setup page displays.
5. In the Does your Internet connection require a login? section, leave the **No** radio button selected.
6. If your Internet connection requires an account name or host name, click the **Edit** button in the Account Name section and enter the account name.
7. If your Internet connection requires a domain name, type it in the **Domain Name (If Required)** field.  
For the other sections on this page, the default settings usually work, but you can change them.
8. Select an Internet IP Address radio button:
  - **Get Dynamically from ISP**. Your ISP uses DHCP to assign your IP address. Your ISP automatically assigns these addresses.
  - **Use Static IP Address**. Enter the IP address, IP subnet mask, and the gateway IP address that your ISP assigned. The gateway is the ISP router to which your router connects.
9. Select a Domain Name Server (DNS) Address radio button:
  - **Get Automatically from ISP**. Your ISP uses DHCP to assign your DNS servers. Your ISP automatically assigns this address.
  - **Use These DNS Servers**. If you know that your ISP requires specific servers, select this option. Enter the IP address of your ISP's primary DNS server. If a secondary DNS server address is available, enter it also.
10. Select a Router MAC Address radio button:
  - **Use Default Address**. Use the default MAC address.
  - **Use Computer MAC Address**. The router captures and uses the MAC address of the computer that you are now using. You must use the one computer that the ISP allows.
  - **Use This MAC Address**. Enter the MAC address that you want to use.
11. Click the **Apply** button.  
Your settings are saved.

12. Click the **Test** button to test your Internet connection.

If the NETGEAR website does not display within one minute, see [Troubleshooting](#) on page 134.

## Specify an Internet connection that uses a login

### To view or change the basic Internet setup:

1. Launch a web browser from a computer or mobile device that is connected to your mesh network.
2. Enter **http://www.routerlogin.net**.  
A login window opens.
3. Enter the router admin user name and password.  
The user name is **admin**. The password is the one that you specified the first time that you logged in. The user name and password are case-sensitive.  
The BASIC Home page displays.
4. Select **Internet**.  
The Internet Setup page displays.
5. In the Does your Internet connection require a login? section, select the **Yes** radio button.
6. From the **Internet Service Provider** menu, select the encapsulation method: **PPPoE**, **L2TP**, or **PPTP**.
7. In the **Login** field, enter the login name that your ISP gave you.  
This login name is often an email address.
8. In the **Password** field, type the password that you use to log in to your Internet service.
9. If your ISP requires a service name, type it in the **Service Name (if Required)** field.
10. From the **Connection Mode** menu, select **Always On**, **Dial on Demand**, or **Manually Connect**.
11. To change the number of minutes until the Internet login times out, in the **Idle Timeout (In minutes)** field, type the number of minutes.  
This is how long the router keeps the Internet connection active when no one on the network is using the Internet connection. A value of 0 (zero) means never log out.
12. Select an Internet IP Address radio button:
  - **Get Dynamically from ISP**. Your ISP uses DHCP to assign your IP address. Your ISP automatically assigns these addresses.

- **Use Static IP Address.** Enter the IP address, IP subnet mask, and the gateway IP address that your ISP assigned. The gateway is the ISP router to which your router connects.

13. Select a Domain Name Server (DNS) Address radio button:

- **Get Automatically from ISP.** Your ISP uses DHCP to assign your DNS servers. Your ISP automatically assigns this address.
- **Use These DNS Servers.** If you know that your ISP requires specific servers, select this option. Enter the IP address of your ISP's primary DNS server. If a secondary DNS server address is available, enter it also.

14. Select a Router MAC Address radio button:

- **Use Default Address.** Use the default MAC address.
- **Use Computer MAC Address.** The router captures and uses the MAC address of the computer that you are now using. You must use the one computer that the ISP allows.
- **Use This MAC Address.** Enter the MAC address that you want to use.

15. Click the **Apply** button.

Your settings are saved.

16. Click the **Test** button to test your Internet connection.

If the NETGEAR website does not display within one minute, see [Troubleshooting](#) on page 134.

## Specify IPv6 Internet connections

You can set up an IPv6 Internet connection if the router does not detect it automatically.

### To set up an IPv6 Internet connection:

1. Launch a web browser from a computer or mobile device that is connected to the router network.
2. Enter **http://www.routerlogin.net**.  
A login window opens.
3. Enter the router admin user name and password.  
The user name is **admin**. The password is the one that you specified the first time that you logged in. The user name and password are case-sensitive.  
The BASIC Home page displays.
4. Select **ADVANCED > Advanced Setup > IPv6**.  
The IPv6 page displays.

- From the **Internet Connection Type** menu, select the IPv6 connection type:
  - If you are not sure, select **Auto Detect** so that the router detects the IPv6 type that is in use.
  - If your Internet connection does not use PPPoe or DHCP, or is not fixed, but is IPv6, select **Auto Config**.

Your Internet service provider (ISP) can provide this information.

- Click the **Apply** button.  
Your settings are saved.

## Requirements for entering IPv6 addresses

IPv6 addresses are denoted by eight groups of hexadecimal quartets that are separated by colons. You can reduce any four-digit group of zeros within an IPv6 address to a single zero or omit it. The following errors invalidate an IPv6 address:

- More than eight groups of hexadecimal quartets
- More than four hexadecimal characters in a quartet
- More than two colons in a row

## Use auto detect for an IPv6 Internet connection

### To set up an IPv6 Internet connection through autodetection:

- Launch a web browser from a computer or mobile device that is connected to the router network.
- Enter **http://www.routerlogin.net**.  
A login window opens.
- Enter the router admin user name and password.  
The user name is **admin**. The password is the one that you specified the first time that you logged in. The user name and password are case-sensitive.  
The BASIC Home page displays.
- Select **ADVANCED > Advanced Setup > IPv6**.  
The IPv6 page displays.
- From the **Internet Connection Type** menu, select **Auto Detect**.  
The page adjusts.

The router automatically detects the information in the following fields:

- **Connection Type.** This field indicates the connection type that is detected.
- **Router's IPv6 Address on WAN.** This field shows the IPv6 address that is acquired for the router's WAN (or Internet) interface. The number after the slash (/) is the length of the prefix, which is also indicated by the underline ( ) under the IPv6 address. If no address is acquired, the field displays Not Available.
- **Router's IPv6 Address on LAN.** This field shows the IPv6 address that is acquired for the router's LAN interface. The number after the slash (/) is the length of the prefix, which is also indicated by the underline ( ) under the IPv6 address. If no address is acquired, the field displays Not Available.

6. Select an IP Address Assignment radio button:

- **Use DHCP Server.** This method passes more information to LAN devices but some IPv6 systems might not support the DHCv6 client function.
- **Auto Config.** This is the default setting.

This setting specifies how the router assigns IPv6 addresses to the devices on your home network (the LAN).

7. (Optional) Select the **Use This Interface ID** check box and specify the interface ID to be used for the IPv6 address of the router's LAN interface.

If you do not specify an ID here, the router generates one automatically from its MAC address.

8. Click the **Apply** button.

Your settings are saved.

## Set up an IPv6 6to4 tunnel Internet connection

The remote relay router is the router to which your router creates a 6to4 tunnel. Make sure that the IPv4 Internet connection is working before you apply the 6to4 tunnel settings for the IPv6 connection.

### To set up an IPv6 Internet connection by using a 6to4 tunnel:

1. Launch a web browser from a computer or mobile device that is connected to the router network.
2. Enter **http://www.routerlogin.net**.  
A login window opens.
3. Enter the router admin user name and password.

The user name is **admin**. The password is the one that you specified the first time that you logged in. The user name and password are case-sensitive.

The BASIC Home page displays.

4. Select **ADVANCED > Advanced Setup > IPv6**.

The IPv6 page displays.

5. From the **Internet Connection Type** menu, select **6to4 Tunnel**.

The page adjusts.

The router automatically detects the information in the Router's IPv6 Address on LAN field. This field shows the IPv6 address that is acquired for the router's LAN interface. The number after the slash (/) is the length of the prefix, which is also indicated by the underline ( ) under the IPv6 address. If no address is acquired, the field displays Not Available.

6. Select a Remote 6to4 Relay Router radio button:

- **Auto**. Your router uses any remote relay router that is available on the Internet. This is the default setting.
- **Static IP Address**. Enter the static IPv4 address of the remote relay router. Your IPv6 ISP usually provides this address.

7. Select an IPv6 Domain Name Server (DNS) Address radio button:

- **Get Automatically from ISP**. Your ISP uses DHCP to assign your DNS servers. Your ISP automatically assigns this address.
- **Use These DNS Servers**. If you know that your ISP requires specific servers, select this option. Enter the IP address of your ISP's primary DNS server. If a secondary DNS server address is available, enter it also.

8. Select an IP Address Assignment radio button:

- **Use DHCP Server**. This method passes more information to LAN devices but some IPv6 systems might not support the DHCPv6 client function.
- **Auto Config**. This is the default setting.

This setting specifies how the router assigns IPv6 addresses to the devices on your home network (the LAN).

9. (Optional) Select the **Use This Interface ID** check box and specify the interface ID to be used for the IPv6 address of the router's LAN interface.

If you do not specify an ID here, the router generates one automatically from its MAC address.

10. Click the **Apply** button.

Your settings are saved.

## Set up an IPv6 pass-through Internet connection

### To set up a pass-through IPv6 Internet connection:

1. Launch a web browser from a computer or mobile device that is connected to the router network.
2. Enter **http://www.routerlogin.net**.  
A login window opens.
3. Enter the router admin user name and password.  
The user name is **admin**. The password is the one that you specified the first time that you logged in. The user name and password are case-sensitive.  
The BASIC Home page displays.
4. Select **ADVANCED > Advanced Setup > IPv6**.  
The IPv6 page displays.
5. From the **Internet Connection Type** menu, select **Pass Through**.  
The page adjusts, but no additional fields display.
6. Click the **Apply** button.  
Your settings are saved.

## Set up an IPv6 fixed Internet connection

### To set up a fixed IPv6 Internet connection:

1. Launch a web browser from a computer or mobile device that is connected to the router network.
2. Enter **http://www.routerlogin.net**.  
A login window opens.
3. Enter the router admin user name and password.  
The user name is **admin**. The password is the one that you specified the first time that you logged in. The user name and password are case-sensitive.  
The BASIC Home page displays.
4. Select **ADVANCED > Advanced Setup > IPv6**.  
The IPv6 page displays.

- From the **Internet Connection Type** menu, select **Fixed**.  
The page adjusts.
- Configure the fixed IPv6 addresses for the WAN connection:
  - IPv6 Address/Prefix Length.** The IPv6 address and prefix length of the router WAN interface.
  - Default IPv6 Gateway.** The IPv6 address of the default IPv6 gateway for the router's WAN interface.
  - Primary DNS Server.** The primary DNS server that resolves IPv6 domain name records for the router.
  - Secondary DNS Server.** The secondary DNS server that resolves IPv6 domain name records for the router.

**Note:** If you do not specify the DNS servers, the router uses the DNS servers that are configured for the IPv4 Internet connection on the Internet Setup page. (See [Manually set up the Internet connection](#) on page 23.)

- Select an IP Address Assignment radio button:
  - Use DHCP Server.** This method passes more information to LAN devices but some IPv6 systems might not support the DHCPv6 client function.
  - Auto Config.** This is the default setting.

This setting specifies how the router assigns IPv6 addresses to the devices on your home network (the LAN).

- In the **IPv6 Address/Prefix Length** fields, specify the static IPv6 address and prefix length of the router's LAN interface.  
If you do not specify an ID here, the router generates one automatically from its MAC address.

- Click the **Apply** button.  
Your settings are saved.

## Set up an IPv6 DHCP Internet connection

### To set up an IPv6 Internet connection with a DHCP server:

- Launch a web browser from a computer or mobile device that is connected to the router network.
- Enter **http://www.routerlogin.net**.  
A login window opens.

3. Enter the router admin user name and password.

The user name is **admin**. The password is the one that you specified the first time that you logged in. The user name and password are case-sensitive.

The BASIC Home page displays.

4. Select **ADVANCED > Advanced Setup > IPv6**.

The IPv6 page displays.

5. From the **Internet Connection Type** menu, select **DHCP**.

The page adjusts.

The router automatically detects the information in the following fields:

- **Router's IPv6 Address on WAN.** This field shows the IPv6 address that is acquired for the router's WAN (or Internet) interface. The number after the slash (/) is the length of the prefix, which is also indicated by the underline ( ) under the IPv6 address. If no address is acquired, the field displays Not Available.
- **Router's IPv6 Address on LAN.** This field shows the IPv6 address that is acquired for the router's LAN interface. The number after the slash (/) is the length of the prefix, which is also indicated by the underline ( ) under the IPv6 address. If no address is acquired, the field displays Not Available.

6. (Optional) In the **User Class (If Required)** field, enter a host name.

Most people can leave this field blank, but if your ISP gave you a specific host name, enter it here.

7. (Optional) In the **Domain Name (If Required)** field, enter a domain name.

You can type the domain name of your IPv6 ISP. Do not enter the domain name for the IPv4 ISP here. For example, if your ISP's mail server is mail.xxx.yyy.zzz, type xxx.yyy.zzz as the domain name. If your ISP provided a domain name, type it in this field. For example, Earthlink Cable might require a host name of home, and Comcast sometimes supplies a domain name.

8. Select an IPv6 Domain Name Server (DNS) Address radio button:

- **Get Automatically from ISP.** Your ISP uses DHCP to assign your DNS servers. Your ISP automatically assigns this address.
- **Use These DNS Servers.** If you know that your ISP requires specific servers, select this option. Enter the IP address of your ISP's primary DNS server. If a secondary DNS server address is available, enter it also.

9. Select an IP Address Assignment radio button:

- **Use DHCP Server.** This method passes more information to LAN devices but some IPv6 systems might not support the DHCv6 client function.
- **Auto Config.** This is the default setting.

This setting specifies how the router assigns IPv6 addresses to the devices on your home network (the LAN).

10. (Optional) Select the **Use This Interface ID** check box and specify the interface ID to be used for the IPv6 address of the router's LAN interface.

If you do not specify an ID here, the router generates one automatically from its MAC address.

11. Click the **Apply** button.  
Your settings are saved.

## Set up an IPv6 PPPoE Internet connection

### To set up a PPPoE IPv6 Internet connection:

1. Launch a web browser from a computer or mobile device that is connected to the router network.

2. Enter **http://www.routerlogin.net**.

A login window opens.

3. Enter the router admin user name and password.

The user name is **admin**. The password is the one that you specified the first time that you logged in. The user name and password are case-sensitive.

The BASIC Home page displays.

4. Select **ADVANCED > Advanced Setup > IPv6**.

The IPv6 page displays.

5. From the **Internet Connection Type** menu, select **PPPoE**.

The page adjusts.

The router automatically detects the information in the following fields:

- **Router's IPv6 Address on WAN.** This field shows the IPv6 address that is acquired for the router's WAN (or Internet) interface. The number after the slash (/) is the length of the prefix, which is also indicated by the underline (\_\_) under the IPv6 address. If no address is acquired, the field displays Not Available.
- **Router's IPv6 Address on LAN.** This field shows the IPv6 address that is acquired for the router's LAN interface. The number after the slash (/) is the length of the

prefix, which is also indicated by the underline (   ) under the IPv6 address. If no address is acquired, the field displays Not Available.

6. In the **Login** field, enter the login information for the ISP connection.  
This is usually the name that you use in your email address. For example, if your main mail account is JerAB@ISP.com, you would type JerAB in this field. Some ISPs (like Mindspring, Earthlink, and T-DSL) require that you use your full email address when you log in. If your ISP requires your full email address, type it in this field.
7. In the **Password** field, enter the password for the ISP connection.
8. In the **Service Name** field, enter a service name.  
If your ISP did not provide a service name, leave this field blank.

**Note:** The default setting of the **Connection Mode** menu is Always On to provide a steady IPv6 connection. The router never terminates the connection. If the connection is terminated, for example, when the modem is turned off, the router attempts to reestablish the connection immediately after the PPPoE connection becomes available again.

9. Select an IPv6 Domain Name Server (DNS) Address radio button:
  - **Get Automatically from ISP.** Your ISP uses DHCP to assign your DNS servers. Your ISP automatically assigns this address.
  - **Use These DNS Servers.** If you know that your ISP requires specific servers, select this option. Enter the IP address of your ISP's primary DNS server. If a secondary DNS server address is available, enter it also.
10. Select an IP Address Assignment radio button:
  - **Use DHCP Server.** This method passes more information to LAN devices but some IPv6 systems might not support the DHCPv6 client function.
  - **Auto Config.** This is the default setting.

This setting specifies how the router assigns IPv6 addresses to the devices on your home network (the LAN).

11. (Optional) Select the **Enable RIPng** check box.  
This enables RIP Next Generation on IPv6 PPPoE Internet connections. RIPng is an extension of RIP that supports IPv6.
12. (Optional) Select the **Use This Interface ID** check box and specify the interface ID to be used for the IPv6 address of the router's LAN interface.  
If you do not specify an ID here, the router generates one automatically from its MAC address.

13. Click the **Apply** button.  
Your settings are saved.

## Use auto config for an IPv6 Internet connection

### To set up an IPv6 Internet connection through auto configuration:

1. Launch a web browser from a computer or mobile device that is connected to the network.
2. Enter **http://www.routerlogin.net**.  
A login window opens.
3. Enter the admin user name and password.  
The user name is **admin**. The password is the one that you specified the first time that you logged in. The user name and password are case-sensitive.  
The BASIC Home page displays.
4. Select **ADVANCED > Advanced Setup > IPv6**.  
The IPv6 page displays.
5. From the **Internet Connection Type** menu, select **Auto Config**.  
The page adjusts.  
The automatically detects the information in the following fields:
  - **Router's IPv6 Address on WAN**. This field shows the IPv6 address that is acquired for the 's WAN (or Internet) interface. The number after the slash (/) is the length of the prefix, which is also indicated by the underline ( ) under the IPv6 address. If no address is acquired, the field displays Not Available.
  - **Router's IPv6 Address on LAN**. This field shows the IPv6 address that is acquired for the 's LAN interface. The number after the slash (/) is the length of the prefix, which is also indicated by the underline ( ) under the IPv6 address. If no address is acquired, the field displays Not Available.
6. (Optional) In the **DHCP User Class (If Required)** field, enter a host name.  
Most people can leave this field blank, but if your ISP gave you a specific host name, enter it here.
7. (Optional) In the **DHCP Domain Name (If Required)** field, enter a domain name.  
You can type the domain name of your IPv6 ISP. Do not enter the domain name for the IPv4 ISP here. For example, if your ISP's mail server is mail.xxx.yyy.zzz, type xxx.yyy.zzz as the domain name. If your ISP provided a domain name, type it in this

field. For example, Earthlink Cable might require a host name of home, and Comcast sometimes supplies a domain name.

8. Select an IPv6 Domain Name Server (DNS) Address radio button:
  - **Get Automatically from ISP.** Your ISP uses DHCP to assign your DNS servers. Your ISP automatically assigns this address.
  - **Use These DNS Servers.** If you know that your ISP requires specific servers, select this option. Enter the IP address of your ISP's primary DNS server. If a secondary DNS server address is available, enter it also.

9. Select an IP Address Assignment radio button:
  - **Use DHCP Server.** This method passes more information to LAN devices but some IPv6 systems might not support the DHCv6 client function.
  - **Auto Config.** This is the default setting.

This setting specifies how the assigns IPv6 addresses to the devices on your home network (the LAN).

10. (Optional) Select the **Use This Interface ID** check box and specify the interface ID to be used for the IPv6 address of the 's LAN interface.

If you do not specify an ID here, the generates one automatically from its MAC address.

11. Click the **Apply** button.  
Your settings are saved.

## Set up an IPv6 6rd Internet connection

The 6rd protocol makes it possible to deploy IPv6 to sites using a service provider's IPv4 network. 6rd uses the service provider's own IPv6 address prefix. This limits the operational domain of 6rd to the service provider's network and is under direct control of the service provider. The IPv6 service provided is equivalent to native IPv6. The 6rd mechanism relies on an algorithmic mapping between the IPv6 and IPv4 addresses that are assigned for use within the service provider's network. This mapping allows for automatic determination of IPv4 tunnel endpoints from IPv6 prefixes, allowing stateless operation of 6rd.

With a 6rd tunnel configuration, the router follows the RFC5969 standard, supporting two ways to establish a 6rd tunnel IPv6 WAN connection:

- **Auto Detect mode.** In IPv6 Auto Detect mode, when the router receives option 212 from the DHCPv4 option, autodetect selects the IPv6 as 6rd tunnel setting. The router uses the 6rd option information to establish the 6rd connection.
- **Manual mode.** Select **6rd Tunnel**. If the router receives option 212, the fields are automatically completed. Otherwise, you must enter the 6rd settings.

### To set up an IPv6 6rd Internet connection:

1. Launch a web browser from a computer or mobile device that is connected to the router network.
2. Enter **http://www.routerlogin.net**.  
A login window opens.
3. Enter the router admin user name and password.  
The user name is **admin**. The password is the one that you specified the first time that you logged in. The user name and password are case-sensitive.

The BASIC Home page displays.

4. Select **ADVANCED > Advanced Setup > IPv6**.  
The IPv6 page displays.
5. From the **Internet Connection Type** menu, select **6rd**.  
The page adjusts.

The router automatically detects the information in the following sections:

- **6rd (IPv6 Rapid Development) Configuration.** The router detects the service provider's IPv4 network and attempts to establish an IPv6 6rd tunnel connection. If the IPv4 network returns 6rd parameters to the router, the page adjusts to display the correct settings in this section.
  - **Router's IPv6 Address on LAN.** This field shows the IPv6 address that is acquired for the router's LAN interface. The number after the slash (/) is the length of the prefix, which is also indicated by the underline ( ) under the IPv6 address. If no address is acquired, the field displays Not Available.
6. Select an IPv6 Domain Name Server (DNS) Address radio button:
    - **Get Automatically from ISP.** Your ISP uses DHCP to assign your DNS servers. Your ISP automatically assigns this address.
    - **Use These DNS Servers.** If you know that your ISP requires specific servers, select this option. Enter the IP address of your ISP's primary DNS server. If a secondary DNS server address is available, enter it also.

7. Select an IP Address Assignment radio button:

- **Use DHCP Server.** This method passes more information to LAN devices but some IPv6 systems might not support the DHCPv6 client function.
- **Auto Config.** This is the default setting.

This setting specifies how the router assigns IPv6 addresses to the devices on your home network (the LAN).

8. (Optional) Select the **Use This Interface ID** check box and specify the interface ID that you want to be used for the IPv6 address of the router's LAN interface.

If you do not specify an ID here, the router generates one automatically from its MAC address.

9. (Optional) In the **MTU Size (in bytes)** field, set an MTU size that is specific to an IPv6 6rd Internet connection.

The default size is 1480 bytes.

10. Click the **Apply** button.

Your settings are saved.

## Manage the MTU size

The maximum transmission unit (MTU) is the largest data packet a network device transmits.

### MTU concepts

When one network device communicates across the Internet with another, the data packets travel through many devices along the way. If a device in the data path uses a lower maximum transmission unit (MTU) setting than the other devices, the data packets must be split or "fragmented" to accommodate the device with the smallest MTU.

The best MTU setting for NETGEAR equipment is often the default value. In some situations, changing the value fixes one problem but causes another. Leave the MTU unchanged unless one of these situations occurs:

- You experience problems connecting to your Internet service, and the technical support of either the Internet service provider (ISP) or NETGEAR recommends changing the MTU setting.  
For example, if a secure website does not open, or displays only part of a web page, you might need to change the MTU.
- You use VPN and experience severe performance problems.

- You used a program to optimize MTU for performance reasons and now you are experiencing connectivity or performance problems.

If you suspect an MTU problem, a common solution is to change the MTU to 1400. If you are willing to experiment, you can gradually reduce the MTU from the maximum value of 1500 until the problem goes away. The following table describes common MTU sizes and applications.

Table 3. Common MTU sizes

MTU	Application
1500	The largest Ethernet packet size. This setting is typical for connections that do not use PPPoE or VPN and is the default value for NETGEAR routers, adapters, and switches.
1492	Used in PPPoE environments.
1472	Maximum size to use for pinging. (Larger packets are fragmented.)
1468	Used in some DHCP environments.
1458	Used in PPPoA environments.
1436	Used in PPTP environments or with VPN.

## Change the MTU size

**CAUTION:** An incorrect MTU setting can cause Internet communication problems. For example, you might not be able to access certain websites, frames within websites, secure login pages, or FTP or POP servers.

### To change the MTU size:

- Launch a web browser from a computer or mobile device that is connected to your mesh network.
- Enter **http://www.routerlogin.net**.  
A login window opens.
- Enter the router admin user name and password.  
The user name is **admin**. The password is the one that you specified the first time that you logged in. The user name and password are case-sensitive.  
The BASIC Home page displays.
- Select **ADVANCED > Setup > WAN Setup**.  
The WAN Setup page displays.

5. In the **MTU Size** field, enter a value from 616 to 1500.
6. Click the **Apply** button.  
Your settings are saved.

# 4

## Control Access to the Internet

---

The router comes with a built-in firewall that helps protect your home network from unwanted intrusions from the Internet.

This chapter contains the following sections:

- [Activate and manage NETGEAR Armor using the Nighthawk app](#)
- [Network access control list](#)
- [Use keywords to block Internet sites](#)
- [Block services from the Internet](#)
- [Delete keywords from the blocked list](#)
- [Prevent blocking on a trusted computer](#)
- [Schedule when to block Internet sites and services](#)
- [Set up security event email notifications](#)

# Activate and manage NETGEAR Armor using the Nighthawk app

NETGEAR Armor™ is an advanced multi-layer cyber security solution that protects not only your network but individual devices as well. NETGEAR Armor protects your devices from viruses, spyware, hackers, spam, and phishing.

For more information about NETGEAR Armor, visit [netgear.com/landings/armor/default.aspx](http://netgear.com/landings/armor/default.aspx).

Use the NETGEAR Nighthawk app to activate and manage NETGEAR Armor. The Nighthawk app is available on the Google Play™ store and the Apple App Store®.

## To activate Armor using the Nighthawk app:

1. Launch the Nighthawk app.  
The dashboard displays.
2. Tap **Security**.  
The Armor page displays.
3. Follow the onscreen instructions to set up Armor.

## Network access control list

You can use the network access control list (ACL) on the router to block or allow access to your network and the Internet. The ACL identifies a WiFi or wired device by its MAC address. The router detects the MAC addresses of the devices on the network and either allows or denies access.

The router detects and stores the MAC addresses of devices that connect to the network, so it lists the MAC addresses both of devices that are currently connected and any that were previously connected.

If you set up a network ACL that *allows* all new devices to connect, the following applies:

- You can either select or manually enter devices that you want to *block* from connecting to the network.
- All other devices are allowed access to the network.

If you set up a network ACL that *blocks* all new devices from connecting, the following applies:

- You can either select or manually enter devices that you want to *allow* access to the network.

- Devices that are currently connected to the network or that were allowed to connect in the past are automatically placed on the network ACL as allowed devices.
- All other devices are denied access to the network.

**Note:** Each network device has a MAC address that serves as a unique identifier. The MAC address is a 12-character physical address, containing the hexadecimal characters 0-9, a-f, or A-F (uppercase or lowercase) only, and separated by colons (for example, 00:09:AB:CD:EF:01). Typically, the MAC address is on the label of a device. If you cannot see the label, you can display the MAC address using the network configuration utilities on your computer or mobile device.

## Enable the network access control list, set the access rule, and allow or block connected devices

When you enable network access control, you must select whether new devices are automatically allowed to access the network or are blocked from accessing the network. By default, devices that are already connected to the network are added to the ACL as allowed, but you can choose to block one or more of these devices from accessing the network.

### To enable and manage the network access control list for the entire network and allow or block connected devices:

1. Launch a web browser from a computer or mobile device that is connected to your mesh network.
2. Enter **http://www.routerlogin.net**.  
A login window opens.
3. Enter the router admin user name and password.  
The user name is **admin**. The password is the one that you specified the first time that you logged in. The user name and password are case-sensitive.  
The BASIC Home page displays.
4. Select **ADVANCED > Security > Access Control**.  
The Access Control page displays.
5. Select the **Turn on Access Control** check box.  
You must select this check box before you can select an access rule and use the Allow and Block buttons. When the Turn on Access Control check box is cleared, all devices are allowed to connect, even if a device is on the list of blocked devices.
6. Click the **Apply** button.  
Your settings are saved. Network access control is enabled.

7. Select an access rule to apply to new devices:

- **Allow all new devices to connect:** With this setting, if you connect a new device to the network, it can access the network. You do not need to enter its MAC address on this page. This option works for most home networks. You can also block one or more devices from accessing the network. For more information, see the following step.
- **Block all new devices from connecting:** With this setting, if you want to allow a new device to connect, you must enter its MAC address on this page. (In this situation, a new device is a device that was not previously connected to the network.) For more information about allowing one or more devices, see the following step.

If you block all *new* devices from connecting, the device that you are currently using to connect to the router web interface, any other devices that are currently connected to the network, and all devices that were allowed to connect to the network in the past *are* still allowed access. That means that these devices are automatically added to the network ACL as allowed devices. If you want to block any of these devices, see the following step.

**Note:** Selecting an access rule does not affect previously blocked or allowed devices. It applies only to *new* devices trying to access the network after you apply this setting.

8. To change access for devices that are connected or were connected to the network, do the following:

- **Currently connected devices:**  
In the table that contains the ACL, the Status column shows either Allowed or Blocked for a device. To change the status, select the check box for the device, and click either the **Allow** button or the **Block** button.

**Note:** If you blocked all new devices from connecting, make sure that the computer or mobile device that you are currently using to access the router web interface shows as Allowed in the Status column.

- **Devices that were connected in the past:**
  - To manage allowed devices that are currently not connected to the network, see [Manage allowed devices currently not on the network](#) on page 45.
  - To manage blocked devices that are currently not connected to the network, see [Manage blocked devices currently not on the network](#) on page 46.

9. Click the **Apply** button.

Your settings are saved.

## Manage allowed devices currently not on the network

If you set up an access control list (ACL) that blocks all new devices from accessing the network, you can add new devices that must be allowed access to the network, remove old devices, or change whether devices that were allowed must now be blocked when they try to connect to the network.

For example, you could add a second computer or mobile device for access to the router web management interface in case the device that you are currently using needs to be removed from the network for repairs.

### To manage allowed devices currently not on the network:

1. Launch a web browser from a computer or mobile device that is connected to your mesh network.
2. Enter **http://www.routerlogin.net**.  
A login window opens.
3. Enter the router admin user name and password.  
The user name is **admin**. The password is the one that you specified the first time that you logged in. The user name and password are case-sensitive.  
The BASIC Home page displays.
4. Select **ADVANCED > Security > Access Control**.  
The Access Control page displays.
5. Click the **View list of allowed devices not currently connected to the network** link.  
A table displays the detected device name, MAC address, and connection type of the devices that are not connected but allowed to access the network.  
In the following steps, we refer to the list of allowed devices not currently connected to the network as *the list of allowed devices*.
6. To add a device to the list of allowed devices, do the following:
  - a. Click the **Add** button.  
The Add Allowed Device page displays.
  - b. Enter the MAC address and device name for the device that you want to allow.
  - c. On the Add Allowed Device page, click the **Apply** button.  
The device is added to the list of allowed devices.

7. To remove a device from the list of allowed devices, do the following:
  - a. Select the check box for the device.
  - b. Click the **Remove from the list** button.  
The device is removed from the list of allowed devices.
  
8. To change the device status by blocking access for a device on the list of allowed devices, do the following:
  - a. Select the check box for the device.
  - b. Click the **Edit** button.  
The Edit Device Name page displays.
  - c. From the **Access Control** menu, selected **Block**.
  - d. On the Edit Device Name page, click the **Apply** button.  
The device is moved to the list of blocked devices not currently connected to the network.
  
9. To change the device name for a device on the list of allowed devices, do the following:
  - a. Select the check box for the device.
  - b. Click the **Edit** button.  
The Edit Device Name page displays.
  - c. In the **Device Name** field, enter a name.
  - d. On the Edit Device Name page, click the **Apply** button.  
The device name is changed on the list of allowed devices.
  
10. Click the **Apply** button.  
Your settings are saved.

## Manage blocked devices currently not on the network

If you set up an access control list (ACL) that allows all new devices to access the network, you can add new devices that must be blocked from accessing the network, remove

old devices, or change whether devices that were blocked must now be allowed when they try to connect to the network.

### To manage blocked devices currently not on the network:

1. Launch a web browser from a computer or mobile device that is connected to your mesh network.
2. Enter **http://www.routerlogin.net**.  
A login window opens.
3. Enter the router admin user name and password.  
The user name is **admin**. The password is the one that you specified the first time that you logged in. The user name and password are case-sensitive.  
The BASIC Home page displays.
4. Select **ADVANCED > Security > Access Control**.  
The Access Control page displays.
5. Click the **View list of blocked devices not currently connected to the network** link.  
The Access Control page displays.  
A table displays the detected device name, MAC address, and connection type of the devices that are not connected and are blocked from accessing the network.  
In the following steps, we refer to the list of blocked devices not currently connected to the network as *the list of blocked devices*.
6. To add a device to the list of blocked devices, do the following:
  - a. Click the **Add** button.  
The Add Blocked Device page displays.
  - b. Enter the MAC address and device name for the device that you want to block.
  - c. On the Add Blocked Device page, click the **Apply** button.  
The device is added to the list of blocked devices.
7. To remove a device from the list of blocked devices, do the following:
  - a. Select the check box for the device.
  - b. Click the **Remove from the list** button.  
The device is removed from the list of blocked devices.

8. To change the device status by allowing access for a device on the list of blocked devices, do the following:
  - a. Select the check box for the device.
  - b. Click the **Edit** button.  
The Edit Device Name page displays.
  - c. From the **Access Control** menu, selected **Allow**.
  - d. On the Edit Device Name page, click the **Apply** button.  
The device is moved to the list of allowed devices not currently connected to the network.
  
9. To change the device name for a device on the list of blocked devices, do the following:
  - a. Select the check box for the device.
  - b. Click the **Edit** button.  
The Edit Device Name page displays.
  - c. In the **Device Name** field, enter a name.
  - d. On the Edit Device Name page, click the **Apply** button.  
The device name is changed on the list of blocked devices.
  
10. Click the **Apply** button.  
Your settings are saved.

## Use keywords to block Internet sites

You can use keywords to block certain Internet sites from your network. You can use blocking all the time or based on a schedule.

### To block Internet sites:

1. Launch a web browser from a computer or mobile device that is connected to the router network.
2. Enter **http://www.routerlogin.net**.  
A login window opens.
3. Enter the router admin user name and password.  
The user name is **admin**. The password is the one that you specified the first time that you logged in. The user name and password are case-sensitive.

The BASIC Home page displays.

4. Select **ADVANCED > Security > Block Sites**.

The Block Sites page displays.

5. Select a keyword blocking option:

- **Per Schedule.** Turn on keyword blocking according to a schedule that you set. For more information, see [Schedule when to block Internet sites and services](#) on page 52.
- **Always.** Turn on keyword blocking all the time, independent of the Schedule page.

6. In the **Type keyword or domain name here** field, enter a keyword or domain that you want to block.

For example:

- Specify XXX to block <http://www.badstuff.com/xxx.html>.
- Specify .com if you want to allow only sites with domain suffixes such as .edu or .gov.
- Enter a period (.) to block all Internet browsing access.

7. Click the **Add Keyword** button.

The keyword is added to the keyword list. The keyword list supports up to 32 entries.

8. Click the **Apply** button.

Keyword blocking takes effect.

## Block services from the Internet

You can block Internet services on your network based on the type of service. You can block the services all the time or based on a schedule.

### To block services:

1. Launch a web browser from a computer or mobile device that is connected to the router network.
2. Enter **<http://www.routerlogin.net>**.  
A login window opens.
3. Enter the router admin user name and password.

The user name is **admin**. The password is the one that you specified the first time that you logged in. The user name and password are case-sensitive.

---

The BASIC Home page displays.

4. Select **ADVANCED > Security > Block Services**.

The Block Services page displays.

5. Specify when to block the services:

- To block the services all the time, select the **Always** radio button.
- To block the services based on a schedule, select the **Per Schedule** radio button.

For information about how to specify the schedule, see [Schedule when to block Internet sites and services](#) on page 52.

6. Click the **Add** button.

The Block Services Setup page displays.

7. To add a service that is in the **Service Type** menu, select the application or service. The settings for this service automatically display in the fields.

8. To add a service or application that is not in the menu, select **User Defined**, and do the following:

- a. If you know that the application uses either TCP or UDP, select the appropriate protocol. Otherwise, select **TCP/UDP** (both).
- b. Enter the starting port and ending port numbers.  
If the service uses a single port number, enter that number in both fields. To find out which port numbers the service or application uses, you can contact the publisher of the application, ask user groups or newsgroups, or search on the Internet.

9. Select a filtering option:

- **Only This IP Address**. Block services for a single computer.
- **IP Address Range**. Block services for a range of computers with consecutive IP addresses on your network.
- **All IP Addresses**. Block services for all computers on your network.

10. Click the **Add** button.

Your settings are saved.

# Delete keywords from the blocked list

## To delete keywords from the list:

1. Launch a web browser from a computer or mobile device that is connected to the router network.
2. Enter **http://www.routerlogin.net**.  
A login window opens.
3. Enter the router admin user name and password.  
The user name is **admin**. The password is the one that you specified the first time that you logged in. The user name and password are case-sensitive.  
The BASIC Home page displays.
4. Select **ADVANCED > Security > Block Sites**.  
The Block Sites page displays.
5. Do one of the following:
  - To delete a single word, select it and click the **Delete Keyword** button.  
The keyword is removed from the list.
  - To delete all keywords on the list, click the **Clear List** button.  
All keywords are removed from the list.
6. Click the **Apply** button.  
Your settings are saved.

# Prevent blocking on a trusted computer

You can exempt one trusted computer from blocking. The computer that you exempt must be assigned a fixed IP address. You can use the reserved IP address feature to specify the IP address. See [Manage reserved LAN IP addresses](#) on page 80.

## To specify a trusted computer:

1. Launch a web browser from a computer or mobile device that is connected to the router network.
2. Enter **http://www.routerlogin.net**.  
A login window opens.
3. Enter the router admin user name and password.

The user name is **admin**. The password is the one that you specified the first time that you logged in. The user name and password are case-sensitive.

The BASIC Home page displays.

4. Select **ADVANCED > Security > Block Sites**.

The Block Sites page displays.

5. Scroll down and select the **Allow trusted IP address to visit blocked sites** check box.
6. In the **Trusted IP Address** field, enter the IP address of the trusted computer.
7. Click the **Apply** button.  
Your settings are saved.

## Schedule when to block Internet sites and services

When you schedule blocking, the same schedule is used to block sites and to block services.

### To schedule blocking:

1. Launch a web browser from a computer or mobile device that is connected to your mesh network.
2. Enter **http://www.routerlogin.net**.  
A login window opens.
3. Enter the router admin user name and password.  
The user name is **admin**. The password is the one that you specified the first time that you logged in. The user name and password are case-sensitive.  
The BASIC Home page displays.
4. Select **ADVANCED > Security > Schedule**.  
The Schedule page displays.
5. Specify when to block keywords and services:
  - **Days to Block**. Select the check box for each day that you want to block the keywords, or select the **Every Day** check box, which automatically selects the check boxes for all days.
  - **Time of Day to Block**. Select a start and end time in 24-hour format, or select the **All Day** check box for 24-hour blocking.

6. Click the **Apply** button.  
Your settings are saved.

## Set up security event email notifications

The router can email you its logs of router activity. The log records router activity and security events such as attempts to access blocked sites or services.

### To set up email notifications:

1. Launch a web browser from a computer or mobile device that is connected to your mesh network.
2. Enter **http://www.routerlogin.net**.  
A login window opens.
3. Enter the router admin user name and password.  
The user name is **admin**. The password is the one that you specified the first time that you logged in. The user name and password are case-sensitive.  
The BASIC Home page displays.
4. Select **ADVANCED > Security > E-mail**.  
The E-mail page displays.
5. Select the **Turn E-mail Notification On** check box.
6. In the **Send to This E-mail Address** field, type the email address to which logs and alerts are to be sent.  
This email address is also used for the From address. If this field is blank, log and alert messages are not sent.
7. In the **Sender** field, enter the email sender's name.
8. In the **Your Outgoing Mail Server** field, enter the name of your ISP outgoing (SMTP) mail server (such as mail.myISP.com).  
You might be able to find this information in the configuration window of your email program. If you leave this field blank, log and alert messages are not sent.
9. In the **Outgoing Mail Server Port Number** field, enter a port number in the field.  
If you do not know the port number, leave the default port number.

10. If your outgoing email server requires authentication, select the **My Mail Server requires authentication** check box, and do the following:
  - a. In the **User Name** field, type the user name for the outgoing email server.
  - b. In the **Password** field, type the password for the outgoing email server.
11. To send alerts when someone attempts to visit a blocked site, select the **Send Alerts Immediately** check box.

Email alerts are sent immediately when someone attempts to visit a blocked site.
12. To send logs based on a schedule, specify these settings:
  - a. From **Send logs according to this schedule** menu, select the schedule type.
  - b. From the **Day** menu, select the day.
  - c. From the **Time** menu, select the time, and select the **am** or **pm** radio button.
13. Click the **Apply** button.

Your settings are saved.

Logs are sent automatically according to the schedule that you set. If the log fills before the specified time, it is sent. After the log is sent, it is cleared from the router memory. If the router cannot email the log and the log buffer fills, the router overwrites the log.

# 5

## Optimize Performance

---

You can set up the router to optimize performance for applications such as Internet gaming, high-definition video streaming, and VoIP communication. By default, the router uses Wi-Fi Multimedia Quality of Service (WMM QoS).

This chapter contains the following sections:

- [Use Dynamic QoS to optimize Internet traffic management](#)
- [Improve network connections with Universal Plug and Play](#)

# Use Dynamic QoS to optimize Internet traffic management

Dynamic Quality of Service (QoS) helps improve your router's Internet traffic management capabilities through better application and device identification, bandwidth allocation, and traffic prioritization techniques. Dynamic QoS resolves traffic congestion when the Internet bandwidth is limited and different demands compete for bandwidth.

## Enable Dynamic QoS

Because not everyone uses Dynamic QoS, it is disabled by default.

### To enable Dynamic QoS:

1. Launch a web browser from a computer or mobile device that is connected to your mesh network.
2. Enter **http://www.routerlogin.net**.  
A login window opens.
3. Enter the router admin user name and password.  
The user name is **admin**. The password is the one that you specified the first time that you logged in. The user name and password are case-sensitive.  
The BASIC Home page displays.
4. Select **QoS**.  
The QoS page displays.
5. Select the **Enable QoS** check box.
6. Specify your Internet bandwidth:
  - **Let Speedtest detect my Internet bandwidth.** We recommend that you use Speedtest to detect your Internet bandwidth.  
To use Speedtest, do the following:
    - a. For more accurate Speedtest results, make sure that no other devices are accessing the Internet.
    - b. Select the **Let Speedtest detect my Internet bandwidth** radio button.
    - c. Click the **Take a Speedtest** button.  
Speedtest determines your Internet bandwidth.

- **I want to define my Internet Bandwidth.** If you know what your download and upload speed are, select this radio button and enter your download and upload speeds in the fields.

7. Click the **Apply** button.  
Your settings are saved.

## Enable or disable the automatic QoS database update

The router uses a QoS database of the most popular applications and services to implement Dynamic QoS. By default, the router automatically updates this database. You can turn off this feature and manually update the database.

### To enable or disable the automatic Dynamic QoS database update:

1. Launch a web browser from a computer or mobile device that is connected to your mesh network.
2. Enter **http://www.routerlogin.net**.  
A login window opens.
3. Enter the router admin user name and password.  
The user name is **admin**. The password is the one that you specified the first time that you logged in. The user name and password are case-sensitive.  
The BASIC Home page displays.
4. Select **QoS**.  
The QoS page displays. If you already enabled Dynamic QoS, the **Enable QoS** check box is selected.
5. Select or clear the **Automatically update performance optimization database** check box.
6. Click the **Apply** button.  
Your settings are saved.

## Manually update the dynamic QoS database

The router uses a QoS database of the most popular applications and services to implement Dynamic QoS. By default, the router automatically updates this database when you enable Dynamic QoS, but if you turned off the automatic update feature, you can manually update the database.

**To manually update the Dynamic QoS database:**

1. Launch a web browser from a computer or mobile device that is connected to your mesh network.
2. Enter **http://www.routerlogin.net**.  
A login window opens.
3. Enter the router admin user name and password.  
The user name is **admin**. The password is the one that you specified the first time that you logged in. The user name and password are case-sensitive.  
The BASIC Home page displays.
4. Select **QoS**.  
The QoS page displays. If you already enabled Dynamic QoS, the **Enable QoS** check box is selected.
5. Click the **Update Now** button.  
The router checks for the newest version of the database and downloads it.
6. Click the **Apply** button.  
Your settings are saved.

## Improve network connections with Universal Plug and Play

Universal Plug and Play (UPnP) helps devices such as Internet appliances and computers access the network and connect to other devices as needed. UPnP devices can automatically discover the services from other registered UPnP devices on the network.

If you use applications such as multiplayer gaming, peer-to-peer connections, or real-time communications such as instant messaging or remote assistance (a feature in Windows XP), enable UPnP.

**To enable Universal Plug and Play:**

1. Launch a web browser from a computer or mobile device that is connected to your mesh network.
2. Enter **http://www.routerlogin.net**.  
A login window opens.
3. Enter the router admin user name and password.



The user name is **admin**. The password is the one that you specified the first time that you logged in. The user name and password are case-sensitive.

The BASIC Home page displays.

4. Select **ADVANCED > Advanced Setup > UPnP**.

The UPnP page displays.

5. Select the **Turn UPnP On** check box.

By default, this check box is selected. UPnP for automatic device configuration can be enabled or disabled. If the **Turn UPnP On** check box is cleared, the router does not allow any device to automatically control router resources, such as port forwarding.

6. Type the advertisement period in minutes.

The advertisement period specifies how often the router broadcasts its UPnP information. This value can range from 1 to 1440 minutes. The default period is 30 minutes. Shorter durations ensure that control points receive current device status at the expense of more network traffic. Longer durations can compromise the freshness of the device status but can significantly reduce network traffic.

7. Type the advertisement time to live in hops.

The time to live for the advertisement is measured in hops (steps) for each UPnP packet sent. Hops are the steps a packet takes between routers. The number of hops can range from 1 to 255. The default value for the advertisement time to live is 4 hops, which should be fine for most home networks. If you notice that some devices are not being updated or reached correctly, it might be necessary to increase this value.

8. Click the **Apply** button.

The UPnP Portmap Table displays the IP address of each UPnP device that is accessing the router and which ports (internal and external) that device opened. The UPnP Portmap Table also displays what type of port is open and whether that port is still active for each IP address.

9. To refresh the information in the UPnP Portmap Table, click the **Refresh** button.

# 6

## Manage WiFi Settings

---

You can customize the mesh network WiFi settings.

This chapter contains the following sections:

- [Change the WiFi password or the WiFi security](#)
- [Add a WiFi network](#)
- [Set up a guest WiFi network](#)
- [Use the WPS wizard for WiFi connections](#)
- [Enable or disable 20/40 MHz coexistence for the 2.4 GHz radio](#)
- [Hide your mesh network's SSID](#)
- [Generate a new backhaul password](#)
- [Enable or disable implicit beamforming](#)
- [Enable or disable AX WiFi](#)
- [Change the region of operation](#)
- [Change the CTS/RTS threshold or preamble mode for a radio](#)

# Change the WiFi password or the WiFi security

The router and satellite come preset with the same WiFi network name (SSID) and the same WiFi security. You can find the SSID and password on the router label and on the satellite label.

If you log in to the router and change the WiFi settings, the router automatically sends the new settings to the satellite. We recommend that you do not disable security.

## To change the WiFi password or the WiFi security:

1. Launch a web browser from a computer or mobile device that is connected your mesh network.
2. Enter **http://www.routerlogin.net**.  
A login window opens.
3. Enter the router admin user name and password.  
The user name is **admin**. The password is the one that you specified the first time that you logged in. The user name and password are case-sensitive.  
The BASIC Home page displays.
4. Select **Wireless**.  
The Wireless Settings page displays.
5. To change the WiFi password, enter a new password in the **Password (Network Key)** field.  
You must enter a phrase of 8 to 63 characters. The **Password (Network Key)** field displays if the **WPA2-PSK [AES]**, **WPA-PSK [TKIP] + WPA2-PSK [AES]**, or **WPA3-Personal** security radio button is selected.
6. To change the WiFi security, select a **Security Options** radio button.
  - **None**. An open WiFi network that does not provide any security. Any WiFi device can join the WiFi network. We recommend that you do not use an open WiFi network.
  - **WPA2-PSK [AES]**. This type of security is Wi-Fi Protected Access (WPA) version 2 with a pre-shared key. It uses WPA2-Personal standard encryption with the AES encryption type.
  - **WPA-PSK [TKIP] + WPA2-PSK [AES]**. This type of security allows clients to use either WPA-Personal [TKIP] or WPA2-Personal [AES].

- **WPA3-Personal.** This type of security enables WiFi devices that support WPA3 to join the router's WiFi network. WPA3 is the latest security standard and is more secure than WPA2.

7. Click the **Apply** button.  
Your settings are saved.

## Add a WiFi network

The router and satellite have one default WiFi network, for which the WiFi network name (SSID) and network key (password) are on the router label and on the satellite label. In addition, the router can support two additional and separate WiFi networks: One 2.4 GHz WiFi network and one 5 GHz WiFi network.

If you add a WiFi network, the router automatically sends the new settings to the satellite so that both the router and satellite broadcast the new WiFi network.

### To add a WiFi network:

1. Launch a web browser from a computer or mobile device that is connected to your mesh network.
2. Enter **http://www.routerlogin.net**.  
A login window opens.
3. Enter the router admin user name and password.  
The user name is **admin**. The password is the one that you specified the first time that you logged in. The user name and password are case-sensitive.  
The BASIC Home page displays.
4. Select **ADVANCED > Advanced Setup > Customize WiFi Network**.  
The Customize WiFi Network page displays.
5. Select the **Customize 2.4 GHz WiFi Network** or **Customize 5 GHz WiFi Network** check box.  
You can add a WiFi network in the 2.4 GHz band and the 5 GHz band.
6. To control the SSID broadcast, select or clear the **Enable SSID Broadcast** check box.  
When this check box is selected, the router broadcasts the SSID so that it displays when you scan for local WiFi networks on your computer or mobile device.
7. To add an SSID, type a name in the **Customized 2.4 GHz WiFi Network Name (SSID)** or **Customized 5 GHz WiFi Network Name (SSID)** field.

The name can be up to 32 characters long and it is case-sensitive. The default SSIDs are NETGEAR\_2G and NETGEAR\_5G.

8. Set the WiFi security by selecting one of the following **Security Options** radio buttons:
  - **None.** An open WiFi network that does not provide any security. Any WiFi device can join the WiFi network. We recommend that you do not use an open WiFi network.
  - **WPA2-PSK [AES].** This type of security is Wi-Fi Protected Access (WPA) version 2 with a pre-shared key. It uses WPA2-Personal standard encryption with the AES encryption type.
  - **WPA-PSK [TKIP] + WPA2-PSK [AES].** This type of security allows clients to use either WPA-Personal [TKIP] or WPA2-Personal [AES].
  - **WPA3-Personal.** This type of security enables WiFi devices that support WPA3 to join the router's WiFi network. WPA3 is the latest security standard and is more secure than WPA2.
9. Set a WiFi password in the **Password (Network Key)** field.

You must enter a phrase of 8 to 63 characters or 64 hexadecimal digits. The **Password (Network Key)** field displays if you select the **WPA2-PSK [AES]**, **WPA-PSK [TKIP] + WPA2-PSK [AES]**, or **WPA3-Personal** security radio button.
10. Click the **Apply** button.

Your settings are saved.
11. Make sure that you can connect wirelessly to the network with its new settings.

If you cannot connect wirelessly, check the following:

  - Is your computer or mobile device connected to another WiFi network in your area? Some WiFi devices automatically connect to the first open network without WiFi security that they discover.
  - Is your computer or mobile device trying to connect to your network with its old settings (before you changed the settings)? If so, update the WiFi network selection in your computer or mobile device to match the current settings for your network.

## Set up a guest WiFi network

A guest network allows visitors to use the Internet without using your WiFi security password or with a different WiFi password. The guest WiFi network can broadcast simultaneously in both the 2.4 GHz and the 5 GHz band. Although the guest network is disabled by default, it is configured as an open network without security.

If you enable the guest WiFi network, the router automatically sends the new settings to the satellite so that both the router and satellite broadcast the guest WiFi network.

### To enable and set up a guest network:

1. Launch a web browser from a computer or mobile device that is connected to your mesh network.
2. Enter **http://www.routerlogin.net**.  
A login window opens.
3. Enter the router admin user name and password.  
The user name is **admin**. The password is the one that you specified the first time that you logged in. The user name and password are case-sensitive.  
The BASIC Home page displays.
4. Select **Guest Network**.  
The Guest Network Settings page displays.
5. Select the **Enable Guest Network** check box.  
By default, the guest WiFi network is disabled.
6. To control the SSID broadcast, select or clear the **Enable SSID Broadcast** check box.  
When this check box is selected, the router broadcasts the SSID so that it displays when you scan for local WiFi networks on your computer or mobile device.
7. Either use the default WiFi network name (SSID) or type a name in the **Guest Wireless Network Name (SSID)** field.  
The default SSID is NETGEAR\_GUEST. If you type another name, it can be up to 32 characters long and it is case-sensitive.
8. Set the WiFi security by selecting one of the following **Security Options** radio buttons:
  - **None**. An open WiFi network that does not provide any security. Any WiFi device can join the WiFi network. We recommend that you do not use an open WiFi network. This is the default setting.
  - **WPA2-PSK [AES]**. This type of security is Wi-Fi Protected Access (WPA) version 2 with a pre-shared key. It uses WPA2-Personal standard encryption with the AES encryption type.
  - **WPA-PSK [TKIP] + WPA2-PSK [AES]**. This type of security allows clients to use either WPA-Personal [TKIP] or WPA2-Personal [AES].
  - **WPA3-Personal**. This type of security enables WiFi devices that support WPA3 to join the router's WiFi network. WPA3 is the latest security standard and is more secure than WPA2.

9. Unless you select **None** in the previous step, set a WiFi password in the **Password (Network Key)** field.

You must enter a phrase of 8 to 63 characters or 64 hexadecimal digits. The **Password (Network Key)** field displays if you select the **WPA2-PSK [AES]**, **WPA-PSK [TKIP] + WPA2-PSK [AES]**, or **WPA3-Personal** security radio button.

10. Click the **Apply** button.

Your settings are saved.

11. Make sure that you can reconnect over WiFi to the guest network.

If you cannot connect over WiFi, check the following:

- If your computer or mobile device is already connected to another WiFi network in your area, disconnect it from that WiFi network and connect it to the WiFi network that the router provides.  
Some WiFi devices automatically connect to the first open network without WiFi security that they discover.
- Does your computer or mobile device display as an attached device?  
If it does, it is connected to the guest network.
- Are you using the correct network name (SSID) and password?

## Use the WPS wizard for WiFi connections

The WPS Wizard helps you add a WPS-enabled device to your WiFi network without typing the WiFi password.

### To use the WPS Wizard:

1. Launch a web browser from a computer or mobile device that is connected to your mesh network.
2. Enter **http://www.routerlogin.net**.  
A login window opens.
3. Enter the router admin user name and password.  
The user name is **admin**. The password is the one that you specified the first time that you logged in. The user name and password are case-sensitive.  
The BASIC Home page displays.
4. Select **ADVANCED > WPS Wizard**.  
A note explaining WPS displays.

5. Click the **Next** button.  
The WPS page displays.
6. Select a setup method:
  - **Push button.** Click the **WPS** button on this page.
  - **PIN Number.** The page adjusts. Enter the client security PIN and click the **Next** button.
7. Within two minutes, go to the WPS-enabled device and use its WPS software to connect to the WiFi network.  
The WPS process automatically sets up yourr WPS-enabled device with the network password when it connects. The router WPS page displays a confirmation message.

## Enable or disable 20/40 MHz coexistence for the 2.4 GHz radio

20/40 coexistence allows a 20 MHz and 40 MHz channel width to be supported simultaneously. By default, 20/40 MHz coexistence is enabled on the 2.4 GHz radio to prevent interference between WiFi networks in your environment at the expense of the WiFi speed. If no other WiFi networks are present in your environment, you can disable 20/40 MHz coexistence to increase the WiFi speed on the 2.4 GHz radio to the maximum supported speed for the WiFi mode.

20/40 MHz coexistence applies to the 2.4 GHz radio.

### To enable or disable 20/40 MHz coexistence for the 2.4 GHz radio:

1. Launch a web browser from a computer or mobile device that is connected to your mesh network.
2. Enter **http://www.routerlogin.net**.  
A login window opens.
3. Enter the router admin user name and password.  
The user name is **admin**. The password is the one that you specified the first time that you logged in. The user name and password are case-sensitive.  
The BASIC Home page displays.
4. Select **ADVANCED > Advanced Setup > Wireless Settings**.  
The Wireless Setup page displays.

5. In the Wireless Network (2.4Ghz b/g/n/ax section, select or clear the **Enable 20/40 MHz Coexistence** check box.

Selecting this check box enables 20/40 MHz coexistence and clearing this check box disables 20/40 MHz coexistence.

By default, 20/40 MHz coexistence is enabled and the check box is selected.

6. Click the **Apply** button.

Your settings are saved. The 2.4 GHz radio restarts and WiFi clients might need to reconnect.

## Hide your mesh network's SSID

By default, your mesh network's WiFi network name (SSID) is broadcasted and visible to other WiFi devices. If you disable SSID broadcasting on your mesh network, the SSID is no longer visible. However, other devices can still connect to the mesh network manually if the SSID, security type, and WiFi password is known.

### To hide your mesh network's SSID:

1. Launch a web browser from a computer or mobile device that is connected to your mesh network.
2. Enter **http://www.routerlogin.net**.  
A login window opens.
3. Enter the router admin user name and password.  
The user name is **admin**. The password is the one that you specified the first time that you logged in. The user name and password are case-sensitive.  
The BASIC Home page displays.
4. Select **ADVANCED > Advanced Setup > Wireless Settings**.  
The Wireless Setup page displays.
5. Clear the **Enable SSID Broadcast** check box.  
Clearing this check box hides the SSID.
6. Click the **Apply** button.  
Your settings are saved.

# Generate a new backhaul password

The backhaul password is a security key that is used in WiFi communication between the router and the satellite. You can generate a new backhaul password. After you generate a new backhaul password, you must use the **Sync** button to build a new backhaul connection so that the router and satellite can communicate with each other using WiFi.

## To generate a new backhaul password:

1. Launch a web browser from a computer or mobile device that is connected to your mesh network.
2. Enter **http://www.routerlogin.net**.  
A login window opens.
3. Enter the router admin user name and password.  
The user name is **admin**. The password is the one that you specified the first time that you logged in. The user name and password are case-sensitive.  
The BASIC Home page displays.
4. Select **ADVANCED > Advanced Setup > Wireless Settings**.  
The Advanced Wireless Settings page displays.
5. In the Backhaul Password section, click the **Generate** button.  
The router generates a new backhaul password.  
Generating a new password might cause the satellite to lose connection from the router. To reconnect, use the **Sync** button.

# Enable or disable implicit beamforming

Beamforming shapes a directional WiFi signal aimed at a WiFi client based on the client's location, as opposed to radiating the signal out in all directions. This feature improves WiFi range and performance. Clients do not need to support beamforming to benefit from implicit beamforming.

## To enable or disable implicit beamforming:

1. Launch a web browser from a computer or mobile device that is connected to your mesh network.
2. Enter **http://www.routerlogin.net**.  
A login window opens.

3. Enter the router admin user name and password.  
The user name is **admin**. The password is the one that you specified the first time that you logged in. The user name and password are case-sensitive.  
The BASIC Home page displays.
4. Select **ADVANCED > Advanced Setup > Wireless Settings**.  
The Wireless Settings page displays.
5. Scroll down below the WPS Settings section and select or clear the **Enable Implicit BEAMFORMING** check box.  
Selecting this check box enables implicit beamforming. Clearing this check box disables implicit beamforming.
6. Click the **Apply** button.  
Your settings are saved.  
If you connected over WiFi to the network, you are disconnected from the network and must reconnect.

## Enable or disable AX WiFi

AX WiFi improves your network's capacity, Internet upload and download speeds, and WiFi range by allowing WiFi traffic from different devices to be concurrently managed. To do this, AX WiFi uses Orthogonal Frequency-Division Multiple-Access (OFDMA), 2x2 multi-user MIMO, and intelligent scheduling.

AX WiFi is enabled by default.

### To enable or disable AX WiFi:

1. Launch a web browser from a computer or mobile device that is connected to your mesh network.
2. Enter **http://www.routerlogin.net**.  
A login window opens.
3. Enter the router admin user name and password.  
The user name is **admin**. The password is the one that you specified the first time that you logged in. The user name and password are case-sensitive.  
The BASIC Home page displays.
4. Select **ADVANCED > Advanced Setup > Wireless Settings**.  
The Wireless Setup page displays.

5. Select or clear the **Enable AX** check box.  
Selecting this check box turns on AX WiFi and clearing this check box turns off AX WiFi.
6. Click the **Apply** button.  
Your settings are saved.

## Change the region of operation

You can change the region of operation, which is region in which you operate the router. For some countries or regions, such as North America, you cannot change the region because it is preset.

**Note:** Make sure the country is set to the location where the device is operating. You are responsible for complying within the local, regional, and national regulations set for channels, power levels, and frequency ranges.

**WARNING:** It might not be legal to operate the router in a region other than the regions listed in the menu. If your country or region is not listed, check with your local government agency.

### To change the region of operation:

1. Launch a web browser from a computer or mobile device that is connected to your mesh network.
2. Enter **http://www.routerlogin.net**.  
A login window opens.
3. Enter the router admin user name and password.  
The user name is **admin**. The password is the one that you specified the first time that you logged in. The user name and password are case-sensitive.  
The BASIC Home page displays.
4. Select **ADVANCED > Advanced Setup > Wireless Settings**.  
The Advanced Wireless Settings page displays.
5. From the **Region** menu, select the region in which the router must operate.
6. Click the **Apply** button.  
Your settings are saved. The router restarts with the settings for the new region.

# Change the CTS/RTS threshold or preamble mode for a radio

For most WiFi networks, the clear to send/request to send (CTS/RTS) threshold and preamble mode work fine and we recommend that you do not change the settings. (In general, these settings are intended for WiFi testing.)

**CAUTION:** Do not change these settings unless directed by NETGEAR support or unless you are sure what the consequences are. Incorrect settings might disable the WiFi function of a radio unexpectedly.

## To change the CTS/RTS threshold or preamble mode for a radio:

1. Launch a web browser from a computer or mobile device that is connected to your mesh network.
2. Enter **http://www.routerlogin.net**.  
A login window opens.
3. Enter the router admin user name and password.  
The user name is **admin**. The password is the one that you specified the first time that you logged in. The user name and password are case-sensitive.  
The BASIC Home page displays.
4. Select **ADVANCED > Advanced Setup > Wireless Settings**.  
The Advanced Wireless Settings page displays.
5. For the 2.4 GHz radio or 5 GHz radio, in the **CTS/RTS Threshold (1-2347)** field, enter a value from 1 to 2437.  
The default value is 2347.

**CAUTION:** Incorrect settings might disable the WiFi function for the selected radio unexpectedly.

6. From the **Preamble Mode** menu for the 2.4 GHz radio (the setting does not apply to the 5 GHz radio), select **Long Preamble**, or **Short Preamble**.
  - **Long Preamble:** A long transmit preamble might provide a more reliable connection or a slightly longer range. This is the default setting.
  - **Short Preamble:** A short transmit preamble might give better performance.

## Nighthawk Tri-band Mesh WiFi 6

**CAUTION:** Incorrect settings might disable the WiFi function for the selected radio unexpectedly.

7. Click the **Apply** button.  
Your settings are saved.

# 7

## Manage Network Settings

---

You can customize the router's network settings. We recommend that you install the router and connect it to the Internet before you change its network settings.

This chapter contains the following sections:

- [View or change the WAN settings](#)
- [Set up a default DMZ server](#)
- [Change the router's device name](#)
- [Change the LAN IP address settings](#)
- [Specify the IP addresses that the router assigns](#)
- [Disable the DHCP server feature in the router](#)
- [Manage reserved LAN IP addresses](#)
- [Set the time zone manually](#)
- [Change the NTP server](#)
- [Set up the router as a WiFi access point](#)
- [Set up a bridge for a port group or VLAN tag group](#)
- [Manage custom static routes](#)

# View or change the WAN settings

You can view or configure wide area network (WAN) settings for the Internet port. You can set up a DMZ (demilitarized zone) server, change the maximum transmit unit (MTU) size, and enable the router to respond to a ping to its WAN (Internet) port.

## To view or change the WAN settings:

1. Launch a web browser from a computer or mobile device that is connected to your mesh network.
2. Enter **http://www.routerlogin.net**.  
A login window opens.
3. Enter the router admin user name and password.  
The user name is **admin**. The password is the one that you specified the first time that you logged in. The user name and password are case-sensitive.  
The BASIC Home page displays.
4. Select **ADVANCED > Setup > WAN Setup**.  
The WAN Setup page displays.

View or change the following settings:

- **Disable Port Scan and DoS Protection.** DoS protection protects your LAN against denial of service attacks such as Syn flood, Smurf Attack, Ping of Death, and many others. Select this check box only in special circumstances.
- **Respond to Ping on Internet Port.** This feature allows your router to be discovered. Use this feature only as a diagnostic tool or for a specific reason.
- **Default DMZ Server.** This feature is sometimes helpful when you are playing online games or videoconferencing, but it makes the firewall security less effective.
- **Disable IGMP Proxying.** IGMP proxying allows a computer on the local area network (LAN) to receive the multicast traffic it is interested in from the Internet. If you do not need this feature, you can select this check box to disable it.
- **MTU Size (in bytes).** The normal MTU (maximum transmit unit) value for most Ethernet networks is 1500 bytes, or 1492 bytes for PPPoE connections. Change the MTU only if you are sure that it is necessary for your ISP connection.
- **NAT Filtering.** Network Address Translation (NAT) determines how the router processes inbound traffic. Secured NAT protects computers on the LAN from attacks from the Internet but might prevent some Internet games, point-to-point applications, or multimedia applications from working. Open NAT provides a much less secured firewall but allows almost all Internet applications to work.

- **Disable SIP ALG.** Some voice and video communication applications do not work well with the SIP ALG. Disabling the SIP ALG might help your voice and video applications to create and accept a call through the router.

5. Click the **Apply** button.

Your settings are saved.

## Set up a default DMZ server

The default DMZ server feature is helpful when you are using some online games and videoconferencing applications that are incompatible with Network Address Translation (NAT). The router is programmed to recognize some of these applications and to work correctly with them, but other applications might not function well. In some cases, one local computer can run the application correctly if the IP address for that computer is entered as the default DMZ server.

**WARNING:** DMZ servers pose a security risk. A computer designated as the default DMZ server loses much of the protection of the firewall and is exposed to exploits from the Internet. If compromised, the DMZ server computer can be used to attack other computers on your network.

The router usually detects and discards incoming traffic from the Internet that is not a response to one of your local computers or a service that you configured on the Port Forwarding/Port Triggering page. Instead of discarding this traffic, you can specify that the router forwards the traffic to one computer on your network. This computer is called the default DMZ server.

### To set up a default DMZ server:

1. Launch a web browser from a computer or mobile device that is connected to your mesh network.
2. Enter **http://www.routerlogin.net**.  
A login window opens.
3. Enter the router admin user name and password.  
The user name is **admin**. The password is the one that you specified the first time that you logged in. The user name and password are case-sensitive.  
The BASIC Home page displays.
4. Select **ADVANCED > Setup > WAN Setup**.  
The WAN Setup page displays.

5. Select the **Default DMZ Server** check box.
6. Type the IP address.
7. Click the **Apply** button.  
Your settings are saved.

## Change the router's device name

The router's default device name is based on its model number. This device name displays in the file manager when you browse your network.

### To change the router's device name:

1. Launch a web browser from a computer or mobile device that is connected to your mesh network.
2. Enter **http://www.routerlogin.net**.  
A login window opens.
3. Enter the router admin user name and password.  
The user name is **admin**. The password is the one that you specified the first time that you logged in. The user name and password are case-sensitive.  
The BASIC Home page displays.
4. Select **ADVANCED > Setup > LAN Setup**.  
The LAN Setup page displays.
5. In the **Device Name** field, type a new name.
6. Click the **Apply** button.  
Your settings are saved.

## Change the LAN IP address settings

The router is preconfigured to use private IP addresses on the LAN side and to act as a DHCP server. The router's default LAN IP configuration is as follows:

- **LAN IP address.** 192.168.1.1
- **Subnet mask.** 255.255.255.0

These addresses are part of the designated private address range for use in private networks and are suitable for most applications. If your network requires a different IP addressing scheme, you can change these settings.

You might want to change these settings if you need a specific IP subnet that one or more devices on the network use, or if you use competing subnets with the same IP scheme.

Router Information Protocol (RIP) allows a router to exchange routing information with other routers. You change the direction and the protocol version.

### To change the LAN IP address or RIP settings:

1. Launch a web browser from a computer or mobile device that is connected to your mesh network.
2. Enter **http://www.routerlogin.net**.  
A login window opens.
3. Enter the router admin user name and password.  
The user name is **admin**. The password is the one that you specified the first time that you logged in. The user name and password are case-sensitive.  
The BASIC Home page displays.
4. Select **ADVANCED > Setup > LAN Setup**.  
The LAN Setup page displays.
5. In the **IP Address** field, type the IP address.
6. In the **IP Subnet Mask** field, type the subnet mask of the router.  
The IP address and subnet mask identify which addresses are local to a specific device and which must be reached through a gateway or router.
7. Change the RIP settings.
  - a. Select the RIP direction:
    - **Both**. The router broadcasts its routing table periodically and incorporates information that it receives.
    - **Out Only**. The router broadcasts its routing table periodically.
    - **In Only**. The router incorporates the RIP information that it receives.
  - b. Select the RIP version:
    - **Disabled**. This is the default setting.
    - **RIP-1**. This format is universally supported. It is adequate for most networks, unless you are using an unusual network setup.

- **RIP-2.** This format carries more information. Both RIP-2B and RIP-2M send the routing data in RIP-2 format. RIP-2B uses subnet broadcasting. RIP-2M uses multicasting.

8. Click the **Apply** button.

Your settings are saved.

If you changed the LAN IP address of the router, you are disconnected when this change takes effect.

9. To reconnect, close your browser, relaunch it, and log in to the router.

## Specify the IP addresses that the router assigns

By default, the router acts as a Dynamic Host Configuration Protocol (DHCP) server. The router assigns IP, DNS server, and default gateway addresses to all computers connected to the LAN. The assigned default gateway address is the LAN address of the router.

These addresses must be part of the same IP address subnet as the router's LAN IP address. Using the default addressing scheme, define a range between 192.168.1.2 and 192.168.1.254, although you can save part of the range for devices with fixed addresses.

### To specify the pool of IP addresses that the router assigns:

1. Launch a web browser from a computer or mobile device that is connected to your mesh network.
2. Enter **http://www.routerlogin.net**.  
A login window opens.
3. Enter the router admin user name and password.  
The user name is **admin**. The password is the one that you specified the first time that you logged in. The user name and password are case-sensitive.  
The BASIC Home page displays.
4. Select **ADVANCED > Setup > LAN Setup**.  
The LAN Setup page displays.
5. Make sure that the **Use Router as DHCP Server** check box is selected.

6. Specify the range of IP addresses that the router assigns:
  - a. In the **Starting IP Address** field, type the lowest number in the range.  
This IP address must be in the same subnet as the router.
  - b. In the **Ending IP Address** field, type the number at the end of the range of IP addresses.  
This IP address must be in the same subnet as the router.
7. Click the **Apply** button.  
Your settings are saved.

The router delivers the following address information to any LAN device that requests a DHCP address:

- An IP address from the range that you define
- Subnet mask
- Gateway IP address (the router's LAN IP address)
- DNS server IP address (the router's LAN IP address)

## Disable the DHCP server feature in the router

By default, the router acts as a DHCP server. The router assigns IP, DNS server, and default gateway addresses to all computers connected to the LAN. The assigned default gateway address is the LAN address of the router.

You can use another device on your network as the DHCP server or specify the network settings of all your computers.

### To disable the DHCP server feature in the router:

1. Launch a web browser from a computer or mobile device that is connected to your mesh network.
2. Enter **http://www.routerlogin.net**.  
A login window opens.
3. Enter the router admin user name and password.  
The user name is **admin**. The password is the one that you specified the first time that you logged in. The user name and password are case-sensitive.  
The BASIC Home page displays.
4. Select **ADVANCED > Setup > LAN Setup**.

The LAN Setup page displays.

5. Clear the **Use Router as DHCP Server** check box.
6. Click the **Apply** button.  
Your settings are saved.
7. (Optional) If this service is disabled and no other DHCP server is on your network, set your computer IP addresses manually so that the computers can access the router.

## Manage reserved LAN IP addresses

When you specify a reserved IP address for a computer on the LAN, that computer always receives the same IP address each time it accesses the router's DHCP server. Assign reserved IP addresses to computers or servers that require permanent IP settings.

### Reserve an IP address

#### To reserve an IP address:

1. Launch a web browser from a computer or mobile device that is connected to your mesh network.
2. Enter **http://www.routerlogin.net**.  
A login window opens.
3. Enter the router admin user name and password.  
The user name is **admin**. The password is the one that you specified the first time that you logged in. The user name and password are case-sensitive.  
The BASIC Home page displays.
4. Select **ADVANCED > Setup > LAN Setup**.  
The LAN Setup page displays.
5. In the Address Reservation section, click the **Add** button.
6. In the **IP Address** field, type the IP address to assign to the computer or server.  
Choose an IP address from the router's LAN subnet, such as 192.168.1.x.
7. Type the MAC address of the computer or server.

**Tip:** If the computer is already on your network, you can copy its MAC address from the Attached Devices page and paste it here.

8. Click the **Apply** button.

The reserved address is entered into the table.

The reserved address is not assigned until the next time the computer contacts the router's DHCP server. Reboot the computer, or access its IP configuration and force a DHCP release and renew.

## Edit a reserved IP address

### To edit a reserved address entry:

1. Launch a web browser from a computer or mobile device that is connected to your mesh network.
2. Enter **http://www.routerlogin.net**.  
A login window opens.
3. Enter the router admin user name and password.  
The user name is **admin**. The password is the one that you specified the first time that you logged in. The user name and password are case-sensitive.  
The BASIC Home page displays.
4. Select **ADVANCED > Setup > LAN Setup**.  
The LAN Setup page displays.
5. Select the radio button next to the reserved address that you want to edit.
6. Click the **Edit** button.  
The Address Reservation page displays.
7. Change the settings.
8. Click the **Apply** button.  
Your settings are saved.

## Delete a reserved IP address entry

### To delete a reserved address entry:

1. Launch a web browser from a computer or mobile device that is connected to your mesh network.
2. Enter **http://www.routerlogin.net**.  
A login window opens.
3. Enter the router admin user name and password.

The user name is **admin**. The password is the one that you specified the first time that you logged in. The user name and password are case-sensitive.

The BASIC Home page displays.

4. Select **ADVANCED > Setup > LAN Setup**.

The LAN Setup page displays.

5. Select the radio button next to the reserved address that you want to delete.
6. Click the **Delete** button.  
The address is removed.

## Set the time zone manually

### To set your time zone manually:

1. Launch a web browser from a computer or mobile device that is connected to your mesh network.
2. Enter **http://www.routerlogin.net**.  
A login window opens.
3. Enter the router admin user name and password.  
The user name is **admin**. The password is the one that you specified the first time that you logged in. The user name and password are case-sensitive.  
The BASIC Home page displays.
4. Select **ADVANCED > Administration > NTP Settings**.  
The NTP Settings page displays.
5. Select your time zone from the menu.
6. If you live in a region that observes daylight saving time, select the **Automatically adjust for daylight savings time** check box.
7. Click the **Apply** button.  
Your settings are saved.

## Change the NTP server

By default, the router uses the NETGEAR Network Time Protocol (NTP) server to sync the network time. You can change the NTP server to your preferred NTP server.

**To change the NTP server to your preferred NTP server:**

1. Launch a web browser from a computer or mobile device that is connected to your mesh network.
2. Enter **http://www.routerlogin.net**.  
A login window opens.
3. Enter the router admin user name and password.  
The user name is **admin**. The password is the one that you specified the first time that you logged in. The user name and password are case-sensitive.  
The BASIC Home page displays.
4. Select **ADVANCED > Administration > NTP Settings**.  
The NTP Settings page displays.
5. Select the **Set your preferred NTP server** radio button.
6. Enter the NTP server domain name or IP address in the **Primary NTP server** field.
7. Click the **Apply** button.  
Your settings are saved.

## Set up the router as a WiFi access point

You can set up the router to run as an access point (AP) on the same local network as another router.

**To set up the router as an AP:**

1. Use an Ethernet cable to connect the Internet port of this router to an Ethernet port on the other router.
2. Launch a web browser from a computer or mobile device that is connected to your mesh network.
3. Enter **http://www.routerlogin.net**.  
A login window opens.
4. Enter the router admin user name and password.  
The user name is **admin**. The password is the one that you specified the first time that you logged in. The user name and password are case-sensitive.  
The BASIC Home page displays.
5. Select **ADVANCED > Advanced Setup > Wireless AP**.  
The Wireless AP page displays.



6. Select the **Enable AP Mode** check box.  
The page adjusts.
7. Select an IP address setting:
  - **Get dynamically from existing router.** The other router on the network assigns an IP address to this router while it is in AP mode.
  - **Use fixed IP settings on this device (not recommended).** Use this setting if you want to manually assign a specific IP address to this router while it is in AP mode. Using this option effectively requires advanced network experience.

**Note:** To avoid interference with other routers or gateways in your network, we recommend that you use different WiFi settings on each router. You can also turn off the WiFi radio on the other router or gateway and use this router only for WiFi client access.
8. Click the **Apply** button.  
The IP address of the router changes, and you are disconnected.
9. To reconnect, close and restart your browser and type **http://www.routerlogin.net**.

## Set up a bridge for a port group or VLAN tag group

Some devices, such as an IPTV, cannot function behind the router's network address translation (NAT) service or firewall. Based on what your Internet service provider (ISP) requires, for the device to connect to the ISP's network directly, you can enable the bridge between the device and the router's Internet port or add new VLAN tag groups to the bridge.

**Note:** If your ISP provides instructions for how to set up a bridge for IPTV and Internet service, follow those instruction.

### Set up a bridge for a port group

If the device that is connected to the router's Ethernet LAN port includes an IPTV device, your ISP might require you to set up a bridge for a port group for the router's Internet interface.

A bridge with a port group prevents packets that are sent between the IPTV device and the router's Internet port from being processed through the router's network address translation (NAT) service.

### To configure a port group and enable the bridge:

1. Launch a web browser from a computer or mobile device that is connected to the router network.
2. Enter **http://www.routerlogin.net**.  
A login window opens.
3. Enter the router admin user name and password.  
The user name is **admin**. The password is the one that you specified the first time that you logged in. The user name and password are case-sensitive.  
The BASIC Home page displays.
4. Select **ADVANCED > Advanced Setup > VLAN/Bridge Settings**.  
The VLAN/Bridge Settings page displays.
5. Select the **Enable VLAN/Bridge Setup** check box.  
The page expands.
6. Select the **By bridge group** radio button.  
The page expands.
7. Select the **Port1** check box.
8. Click the **Apply** button.  
Your settings are saved.

## Set up a bridge for a VLAN tag group

If the device that is connected to the router's Ethernet LAN port includes an IPTV device, your ISP might require you to set up a bridge for a VLAN tag group for the router's Internet interface.

If you are subscribed to IPTV service, the router might require VLAN tags to distinguish between the Internet traffic and the IPTV traffic. A bridge with a VLAN tag group prevents packets that are sent between the IPTV device and the router's Internet port from being processed through the router's network address translation (NAT) service.

You can add VLAN tag groups to a bridge and assign VLAN IDs and priority values to each VLAN tag group.

### To add a VLAN tag group and enable the bridge:

1. Launch a web browser from a computer or mobile device that is connected to the router network.
2. Enter **http://www.routerlogin.net**.

A login window opens.

3. Enter the router admin user name and password.  
The user name is **admin**. The password is the one that you specified the first time that you logged in. The user name and password are case-sensitive.  
The BASIC Home page displays.
4. Select **ADVANCED > Advanced Setup > VLAN/Bridge Settings**.  
The VLAN/Bridge Settings page displays.
5. Select the **Enable VLAN/Bridge Setup** check box.  
The page expands.
6. Select the **Enable VLAN Tag** radio button.  
The page expands.
7. Click the **Add** button.  
The Add VLAN Rule page displays.
8. Specify the following settings for the VLAN tag group:
  - **Name**. Enter a name for the VLAN tag group.  
The name can be up to 10 characters.
  - **VLAN ID**. Enter a value from 1 to 4094.
  - **Priority**. Enter a value from 0 to 7.
9. Select the **Port1** check box.
10. Click the **Add** button.  
The VLAN tag group is added.
11. Click the **Apply** button.  
Your settings are saved.

## Set up an IPTV port

You can set up the router to create an Internet Protocol television (IPTV) port that can lease an IP address from your IPTV service provider. Use this feature only if you subscribe to an IPTV service and your IPTV service requires an intranet address.

Some IPTV ports cannot work behind NAT because the IPTV port requires an IP address within the Internet service provider's network (intranet address). You can set up a bridge connection from the WAN port to the LAN port. The LAN port becomes an IPTV port with direct access to the WAN without going through NAT.

### To configure an IPTV port:

1. Launch a web browser from a computer or mobile device that is connected to your mesh network.
2. Enter **http://www.routerlogin.net**.  
A login window opens.
3. Enter the router user name and password.  
The user name is **admin**. The password is the one that you specified the first time that you logged in. The user name and password are case-sensitive.  
The BASIC Home page displays.
4. Select **ADVANCED > Advanced Setup > VLAN/Bridge Settings**.  
The VLAN/Bridge Settings page displays.
5. Select the **Enable VLAN/Bridge Setup** check box.  
The page expands.
6. Select the **By bridge group** radio button.  
The page expands.
7. Select the **Port1** check box:
8. Click the **Apply** button.  
Your settings are saved.

## Manage custom static routes

For almost all Internet traffic, routes are automatically and dynamically selected. You can also set up a fixed, static route. Typically, you only need to add static routes when you have more than one router or multiple IP subnets on your network.

As an example of when a static route is needed, consider the following case:

- Your main Internet access is through a cable modem to your ISP. The cable modem is connected to your router.
- Your network also includes an ADSL router that you use to access a remote office site. This ADSL router is connected to a DSL modem, which is used on-demand only.
- Your LAN subnet is 192.168.1.0, and the ADSL router's address on your LAN is 192.168.1.100.
- The public IP address range at the remote office site is 134.177.0.0.

When you set up your router, two implicit static routes were created:

1. A default route was created between your router and the cable modem that connects to your ISP.
2. A second static route was created between your router and your LAN for all 192.168.1.0 addresses.

With this configuration, if you try to access a device on the 134.177.0.0 network at the remote office site, your router forwards your request to your ISP. In turn, the ISP forwards your request to the remote office site, where the firewall will deny the request.

In this situation, you must define a static route, telling your router to access 134.177.0.0 addresses through your ADSL router at its LAN address of 192.168.1.100.

Here is an example static route setting for this configuration:

- **Destination IP address and subnet mask settings:** The route applies to all addresses at the remote site, so set the destination IP address to 134.177.0.0 and the subnet mask to 255.255.255.0.
- **Gateway IP address:** Traffic for addresses in the 134.177.0.0 network must be forwarded to the ADSL router, so set the gateway IP address to 192.168.1.100 (the ADSL router's address on your LAN).
- **Private route:** Make the static route private as a security precaution in case Routing Information Protocol (RIP) is activated. A private route is not reported in RIP messages.

## Set up a static route

### To set up a static route:

1. Launch a web browser from a computer or mobile device that is connected to your mesh network.
2. Enter **http://www.routerlogin.net**.  
A login window opens.
3. Enter the router admin user name and password.  
The user name is **admin**. The password is the one that you specified the first time that you logged in. The user name and password are case-sensitive.  
The BASIC Home page displays.
4. Select **ADVANCED > Advanced Setup > Static Routes**.  
The Static Routes page displays.
5. Click the **Add** button.  
The page adjusts.

6. In the **Route Name** field, type a name for this static route (for identification purposes only).
7. To limit access to the LAN only, select the **Private** check box.  
If the **Private** check box is selected, the static route is not reported in RIP.
8. To prevent the route from becoming active, clear the **Active** check box.  
In some situations, you might want to set up a static route but keep it disabled until a later time. By default, the **Active** check box is selected and a route becomes active after you click the **Apply** button.
9. Enter the following settings:
  - **Destination IP Address.** Enter the IP address for the final destination of the route.
  - **IP Subnet Mask.** Enter the IP subnet mask for the final destination of the route. If the destination is a single host, enter **255.255.255.255**.
  - **Gateway IP Address.** Enter the IP address of the gateway.  
The IP address of the gateway must be on the same LAN segment as the router.
  - **Metric.** Enter a number from 2 through 15.  
This value represents the number of routers between your network and the destination. Usually, a setting of 2 or 3 works, but if this is a direct connection, set it to **2**.
10. Click the **Apply** button.  
Your settings are saved. The static route is added to the table on the Static Routes page.

## Edit a static route

### To edit a static route:

1. Launch a web browser from a computer or mobile device that is connected to your mesh network.
2. Enter **http://www.routerlogin.net**.  
A login window opens.
3. Enter the router admin user name and password.  
The user name is **admin**. The password is the one that you specified the first time that you logged in. The user name and password are case-sensitive.  
The BASIC Home page displays.
4. Select **ADVANCED > Advanced Setup > Static Routes**.

The Static Routes page displays.

5. In the table, select the radio button for the route.
6. Click the **Edit** button.  
The Static Routes page adjusts.
7. Edit the route information.
8. Click the **Apply** button.  
Your settings are saved.

## Delete a static route

### To delete a static route:

1. Launch a web browser from a computer or mobile device that is connected to your mesh network.
2. Enter **http://www.routerlogin.net**.  
A login window opens.
3. Enter the router admin user name and password.  
The user name is **admin**. The password is the one that you specified the first time that you logged in. The user name and password are case-sensitive.  
The BASIC Home page displays.
4. Select **ADVANCED > Advanced Setup > Static Routes**.  
The Static Routes page displays.
5. In the table, select the radio button for the route.
6. Click the **Delete** button.  
The route is removed from the table.

# 8

## Manage your Router and Satellite

---

This chapter describes the settings for administering and maintaining your router, satellite, and mesh network.

The chapter contains the following sections:

- [Update the router and satellite firmware](#)
- [Change the admin password](#)
- [Enable admin password reset](#)
- [Reset the admin password](#)
- [Always use HTTPS to access the router](#)
- [View information about the router, the Internet port, and WiFi settings](#)
- [Display the statistics of the Internet port](#)
- [Check the Internet connection status](#)
- [View and manage logs of router activity](#)
- [View devices currently on the mesh network](#)
- [View the satellite status in the satellite web interface](#)
- [Monitor Internet traffic](#)
- [Set up and manage Dynamic DNS](#)
- [Manage the router configuration file](#)
- [Return the router or satellite to its factory default settings](#)
- [Connect to your router with Anywhere Access](#)

# Update the router and satellite firmware

You can use the router web interface to check if new firmware is available and update your router and satellite, or you can manually update the firmware for your router and satellite.

## Check for new firmware and update the router and satellite

The firmware (routing software) is stored in flash memory. You might see a message at the top of the pages when new firmware is available. You can respond to that message to update the firmware or you can check to see if new firmware is available and update your router and satellite.

**Note:** We recommend that you connect a computer to the router using an Ethernet connection to update the firmware.

### To check for new firmware and update your router and satellite:

1. Launch a web browser from a computer or mobile device that is connected to your mesh network.
2. Enter **http://www.routerlogin.com**.  
A login window opens.
3. Enter the router admin user name and password.  
The user name is **admin**. The password is the one that you specified the first time that you logged in. The user name and password are case-sensitive.  
The BASIC Home page displays.
4. Select **ADVANCED > Administration > Router Update > Online Update**.  
The Router Update page displays.
5. Click the **Check** button.  
The router finds new firmware information if any is available and displays a message asking if you want to download and install it.
6. If new firmware is available, click the **Yes** button.  
The router locates and downloads the firmware and begins the update.

**WARNING:** To avoid the risk of corrupting the firmware, do not interrupt the update. For example, do not close the browser, click a link, or load a new page. Do not turn off the router or satellite.

When the download is complete, your router and satellite restart. The update process typically takes about one minute. Read the new firmware release notes to find out if you must reconfigure the router after updating.

## Manually update the firmware

If a satellite is connected to your router, you can log in to the router to manually upload the firmware on your satellite.

**WARNING:** We recommend that you always update the firmware on your satellite first, and then update your router. Also, do not update the firmware on your router and satellite at the same time, and do not update more than one mesh device (router or satellite) at a time. If you need to update more than one mesh device, wait for the first mesh device to finish updating before updating your next mesh device.

### **To manually update the firmware on your router and satellite, follow these high level steps:**

1. Visit [netgear.com/support](http://netgear.com/support) and download the firmware for both your router and satellite.
2. Update the firmware on your satellite.  
For more information, see [Manually update satellite firmware](#) on page 93.
3. Update the firmware on your router.  
For more information, see [Manually update router firmware](#) on page 94.

**Manually update satellite firmware** We recommend that you update your satellite's firmware *before* you update the router's firmware.

### **To manually update your satellite's firmware:**

1. Launch a web browser from a computer or mobile device that is connected to your mesh network.
2. Enter **http://www.routerlogin.com**.  
A login window opens.
3. Enter the router admin user name and password.  
The user name is **admin**. The password is the one that you specified the first time that you logged in. The user name and password are case-sensitive.  
The BASIC Home page displays.
4. Select **ADVANCED > Administration > Router Update > Manual Update**.  
The Router Update page displays.

5. In the satellite section, and select your satellite.  
The satellite's Router Update page opens.

**Note:** If you have more than one satellite, only update one satellite at a time. You must wait for the first satellite to finish updating before updating the next satellite.

6. Click the **Browse** button.
7. Locate and select the satellite firmware file that you downloaded.  
The firmware file name ends in `.img` or `.chk`.
8. Click the **Upload** button.  
The firmware on your satellite is updated.  
It takes a few minutes to complete the process.
9. After satellite finishes updating, on the satellite web interface, select **Status** and double-check the firmware version on the Status page.

**Manually update router firmware** We recommend that you update your satellite's firmware *before* you update the router's firmware.

**WARNING:** Make sure that your satellite is ready updating its firmware before updating your router's firmware.

### To manually update your router's firmware:

1. Launch a web browser from a computer or mobile device that is connected to your mesh network.
2. Enter **`http://www.routerlogin.com`**.  
A login window opens.
3. Enter the admin user name and password.  
The user name is **admin**. The password is the one that you specified the first time that you logged in. The user name and password are case-sensitive.  
The BASIC Home page displays.
4. Select **ADVANCED > Administration > Router Update > Manual Update**.  
The Router Update page displays.
5. Click the **Browse** button.
6. Locate and select the router firmware file you downloaded.  
The firmware file name ends in `.img`.

7. Click the **Upload** button.  
The firmware is updated.

**Manage the firmware update settings** You can set the router to automatically update to future firmware versions as they become available.

**To manage automatic updates for future firmware versions:**

1. Launch a web browser from a computer or mobile device that is connected to your mesh network.
2. Enter **http://www.routerlogin.net**.  
A login window opens.
3. Enter the router admin user name and password.  
The user name is **admin**. The password is the one that you specified the first time that you logged in. The user name and password are case-sensitive.  
The BASIC Home page displays.
4. Select **ADVANCED > Administration > Router Update > Manual Update**.  
The Router Update page displays.
5. In the Router Auto Firmware Update section, select one of the following radio buttons.
  - **Enable**. The router automatically updates to future firmware versions as they become available. This is the default setting. We recommend that you keep this setting.
  - **Disable**. The router does not automatically update to future firmware versions. You must manually update to future firmware versions.
6. Click the **Apply** button.  
Your settings are saved.

## Change the admin password

The admin password is the one you specified the first time you logged in. You can change this password.

**Note:** The ideal password contains no dictionary words from any language and contains uppercase and lowercase letters, numbers, and symbols. It can be up to 30 characters.

**To change the password for the admin user name:**

1. Launch a web browser from a computer or mobile device that is connected to your mesh network.
2. Enter **http://www.routerlogin.net**.  
A login window opens.
3. Enter the router admin user name and password.  
The user name is **admin**. The password is the one that you specified the first time that you logged in. The user name and password are case-sensitive.  
The BASIC Home page displays.
4. Select **ADVANCED > Administration > Set Password**.  
The Set Password page displays.
5. Type the old password in the **Old Password** field.
6. Type the new password in the **Set Password** and **Repeat New Password** fields.
7. Click the **Apply** button.  
Your settings are saved.

## Enable admin password reset

The router admin password is used to log in to your router web interface. We recommend that you enable password reset so that you can reset the password if it is forgotten. This reset process is supported in Internet Explorer, Firefox, and Chrome browsers but not in the Safari browser.

**To enable password reset:**

1. Launch a web browser from a computer or mobile device that is connected to the router network.
2. Enter **http://www.routerlogin.net**.  
A login window opens.
3. Enter the router admin user name and password.  
The user name is **admin**. The password is the one that you specified the first time that you logged in. The user name and password are case-sensitive.  
The BASIC Home page displays.
4. Select **ADVANCED > Administration > Set Password**.  
The Set Password page displays.



5. Select the **Enable Password Reset** check box.
6. Select two security questions and provide answers to them.
7. Click the **Apply** button.  
Your settings are saved.

## Reset the admin password

If you set up the password reset feature, you can reset your router admin password if you forgot it.

### To reset your admin password:

1. Launch a web browser from a computer or mobile device that is connected to your mesh network.
2. Enter **http://www.routerlogin.net**.  
A login window opens.
3. Click the **Cancel** button.  
If password reset is enabled, you are prompted to enter the serial number of the router.  
The serial number is on the router label.
4. Enter the serial number of the router.
5. Click the **Continue** button.  
The Router Password Reset page displays.
6. Enter your router's serial number in the field.  
Your router's serial number can be found on the router label.
7. Click the **Continue** button.  
You are requested to enter a new admin password and to set new security questions.
8. Enter your new admin password, set new security questions, and click the **Next** button.  
Your settings are saved.
9. Click the **Login** button.  
A login window opens.
10. With your new admin password, log in to the router.

# Always use HTTPS to access the router

You can configure the router to require HTTPS connections between your web browser and the router web interface, for example, "https://www.routerlogin.net". When you enable the HTTPS requirement, connection requests to the router web interface that specify HTTP are automatically converted to HTTPS.

**Note:** After you enable the HTTPS requirement, when you enter **http://www.routerlogin.net**, your browser might display a security warning because of the self-signed certificate on the router. This is expected behavior. You can proceed, or add an exception for the security warning. For more information, visit <https://kb.netgear.com/000062980/what-to-do-in-case-of-security-message>.

To require HTTPS connections:

1. Launch a web browser from a computer or mobile device that is connected to your mesh network.
2. Enter **http://www.routerlogin.net**.  
A login window opens.
3. Enter the router admin user name and password.  
The user name is **admin**. The password is the one that you specified the first time that you logged in. The user name and password are case-sensitive.  
The BASIC Home page displays.
4. Select **ADVANCED > Advanced Setup > Web Services Management**.  
The Web Services Management page displays.
5. Select the **Always Use HTTPS to Access Router** check box.
6. Click the **Apply** button.  
Your settings are saved.

# View information about the router, the Internet port, and WiFi settings

You can view router information, the Internet port status, WiFi settings, and information about specific WiFi networks.

## **To view information about the router, Internet port, WiFi settings, and WiFi networks:**

1. Launch a web browser from a computer or mobile device that is connected to your mesh network.
2. Enter **http://www.routerlogin.net**.  
A login window opens.
3. Enter the router admin user name and password.  
The user name is **admin**. The password is the one that you specified the first time that you logged in. The user name and password are case-sensitive.  
The BASIC Home page displays.
4. Click the **ADVANCED** tab.  
The ADVANCED Home page displays.  
The information on this page uses the following color coding:
  - A green icon indicates that the Internet connection is fine and no problems exist. For a WiFi network, the network is enabled and secured.
  - A red icon indicates that configuration problems exist for the Internet connection or the connection is down. For a WiFi network, the network is disabled or down.
  - An amber icon indicates that the Internet port is configured but cannot get an Internet connection (for example, because the cable is disconnected), that a WiFi network is enabled but unprotected, or that another situation that requires your attention occurred.

# Display the statistics of the Internet port

## **To display the statistics of the Internet port:**

1. Launch a web browser from a computer or mobile device that is connected to your mesh network.
2. Enter **http://www.routerlogin.net**.

A login window opens.

3. Enter the router admin user name and password.

The user name is **admin**. The password is the one that you specified the first time that you logged in. The user name and password are case-sensitive.

The BASIC Home page displays.

4. Click the **ADVANCED** tab.

The ADVANCED Home page displays.

5. In the Internet Port pane, click the **Show Statistics** button.

The Show Statistics window opens and displays following information:

- **System Up Time.** The time elapsed since the router was last restarted.
- **Port.** The statistics for the WAN (Internet) port, LAN (Ethernet) port, and WLANs displays. For each port, the following information displays:
  - **Status.** The link status of the port.
  - **TxPkts.** The number of packets transmitted on this port since the router was last started.
  - **RxPkts.** The number of packets received on this port since the router was last started.
  - **Collisions.** The number of collisions on this port since the router was last started.
  - **Tx B/s.** The current transmission (outbound) bandwidth used on the WAN port and LAN port.
  - **Rx B/s.** The current reception (inbound) bandwidth used on the WAN port and LAN port.
  - **Up Time.** The time elapsed since this port acquired the link.
- **Poll Interval.** The interval at which the statistics are updated on this page.

6. To change the polling frequency, enter a time in seconds in the **Poll Interval** field and click the **Set Interval** button.

To stop the polling entirely, click the **Stop** button.

# Check the Internet connection status

## To check the Internet connection status:

1. Launch a web browser from a computer or mobile device that is connected to the router network.
2. Enter **http://www.routerlogin.net**.  
A login window opens.
3. Enter the router admin user name and password.  
The user name is **admin**. The password is the one that you specified the first time that you logged in. The user name and password are case-sensitive.  
The BASIC Home page displays.
4. Click the **ADVANCED** tab.  
The ADVANCED Home page displays.
5. In the Internet Port pane, click the **Connection Status** button.  
The Connection Status window opens. The information that displays depends on the type of Internet connection.  
For example, if your Internet connection does not require a login and the router receives an IP address automatically, the window displays the following information:
  - **IP Address.** The IP address that is assigned to the .
  - **Subnet Mask.** The subnet mask that is assigned to the .
  - **Default Gateway.** The IP address for the default gateway that the communicates with.
  - **DHCP Server.** The IP address for the Dynamic Host Configuration Protocol server that provides the TCP/IP configuration for all the computers that are connected to the .
  - **DNS Server.** The IP address of the Domain Name Service server that provides translation of network names to IP addresses.
  - **Lease Obtained.** The date and time when the lease was obtained.
  - **Lease Expires.** The date and time that the lease expires.
6. To release (stop) the Internet connection, click the **Release** button.
7. To renew (restart) the Internet connection, click the **Renew** button.
8. To exit the screen, click the **Close Window** button.

# View and manage logs of router activity

The logs are a detailed record of the websites you accessed or attempted to access and many other router actions. Up to 256 entries are stored in the log.

## To view and manage logs:

1. Launch a web browser from a computer or mobile device that is connected to your mesh network.
2. Enter **http://www.routerlogin.net**.  
A login window opens.
3. Enter the router admin user name and password.  
The user name is **admin**. The password is the one that you specified the first time that you logged in. The user name and password are case-sensitive.  
The BASIC Home page displays.
4. Select **ADVANCED > Administration > Logs**.  
The Logs page displays and shows information such as the following:
  - **Action**. The action that occurred, such as whether Internet access was blocked or allowed.
  - **Source IP**. The IP address of the initiating device for the log entry.
  - **Target address**. The MAC or IP address of the device visited or to which access was attempted.
  - **Date and time**. The date and time the log entry was recorded.Other information might be displayed.
5. To customize the logs, scroll down and clear or select the check boxes in the Include in Log section.
6. To refresh the log screen, click the **Refresh** button.
7. To clear the log entries, click the **Clear Log** button.
8. To email the log immediately, click the **Send Log** button.  
You must set up email notifications in order to receive the logs. The router to emails the logs to the address that you specified when you set up email notifications. For more information, see [Set up security event email notifications](#) on page 53.
9. Click the **Apply** button.  
Your settings are saved.

# View devices currently on the mesh network

You can view all satellites and devices that are currently connected to your mesh network.

## To view devices on the mesh network:

1. Launch a web browser from a computer or mobile device that is connected to your mesh network.
2. Enter **http://www.routerlogin.net**.  
A login window opens.
3. Enter the router admin user name and password.  
The user name is **admin**. The password is the one that you specified the first time that you logged in. The user name and password are case-sensitive.  
The BASIC Home page displays.

4. Select **Attached Devices**.  
The Attached Devices page displays.

The Connected Satellite table displays the following information:

- **Device Name:** The satellite model, device name, and IP address.
- **IP Address:** The satellite IP address. This IP address can change because the router assigns an IP address to each satellite when it joins the network.
- **Connection Type:** The satellite is connected to the mesh network through a WiFi or wired Ethernet connection.
- **Connected Mesh Device:** The router or (other) satellite that the satellite is connected to. The Orbi router's or satellite's MAC address also displays.
- **Backhaul Status:** The quality of the backhaul status between the satellite and the router or (other) satellite.

The Connected Devices table displays the following information:

- **Status:** Displays only if network access control (see [Network access control list](#) on page 42) is enabled. The field displays if a device is allowed or blocked.
- **Connection Type:** The device is connected to the mesh network through a WiFi or wired Ethernet connection.
- **Device Name:** The device model, device name, and IP address.

- **IP Address:** The device IP address. This IP address can change because the router assigns an IP address to each device when it joins the network.
- **MAC Address:** The device MAC address. The unique MAC address for each device does not change.

# View the satellite status in the satellite web interface

The satellite web interface lets you view satellite status information that you cannot view from the router web interface. You can find the IP address of the satellite in the router web interface. You can then launch a new web browser window, enter the satellite IP address, and access the satellite web interface.

To view your satellite's status, it must be connected to your mesh network.

### To view your satellite's status:

1. Launch a web browser from a computer or mobile device that is connected to your mesh network.
2. Enter **http://www.routerlogin.net**.  
A login window opens.
3. Enter the router admin user name and password.  
The user name is **admin**. The password is the one that you specified the first time that you logged in. The user name and password are case-sensitive.  
The BASIC Home page displays.
4. Select **Attached Devices**.  
The Attached Devices page displays.
5. In the Connected Satellite table, find your satellite's IP address.
6. Launch a new web browser window and enter your satellite's IP address in the web browser's address bar.  
A login window opens.
7. Enter the same admin user name and password that you entered for the router.  
The satellite status displays. The page displays information about the satellite connections, hardware and firmware versions, and the WiFi networks in the 2.4 GHz and 5 GHz bands.

8. To view detailed information about devices that are connected to the satellite networks, select **Attached Devices**.

The Attached Devices page displays. For each device, the page displays the connection type, IP address, device name, and MAC address.

## Monitor Internet traffic

Traffic metering allows you to monitor the volume of Internet traffic that passes through the router Internet port. You can set limits for traffic volume.

### To monitor Internet traffic:

1. Launch a web browser from a computer or mobile device that is connected to your mesh network.
2. Enter **http://www.routerlogin.net**.  
A login window opens.
3. Enter the router admin user name and password.  
The user name is **admin**. The password is the one that you specified the first time that you logged in. The user name and password are case-sensitive.  
The BASIC Home page displays.
4. Select **ADVANCED > Advanced Setup > Traffic Meter**.  
The Traffic Meter page displays.
5. Select the **Enable Traffic Meter** check box.
6. To control the volume of Internet traffic, use either the traffic volume control feature or the connection time control feature:
  - Select the **Traffic volume control by** radio button and then select one of the following options:
    - **No Limit**. No restriction is applied when the traffic limit is reached.
    - **Download only**. The restriction is applied to incoming traffic only.
    - **Both Directions**. The restriction is applied to both incoming and outgoing traffic.
  - Select the **Connection time control** radio button and enter the allowed hours in the **Monthly limit** field.
7. If your ISP charges for extra data volume when you make a new connection, enter the extra data volume in MB in the **Round up data volume for each connection by** field.

8. In the Traffic Counter section, set the traffic counter to begin at a specific time and date.

To start the traffic counter immediately, click the **Restart Counter Now** button.

9. In the Traffic Control section, specify whether the router should issue a warning message before the monthly limit of Mbytes or hours is reached.

By default, the value is 0 and no warning message is issued. You can select one of the following to occur when the limit is attained:

- The Internet LED blinks white or amber.
- The Internet connection is disconnected and disabled.

10. Click the **Apply** button.

The Internet Traffic Statistics section helps you to monitor the data traffic.

11. To update the Traffic Statistics section, click the **Refresh** button.

12. To display more information about the data traffic on your router and to change the poll interval, click the **Traffic Status** button.

## Set up and manage Dynamic DNS

Internet service providers (ISPs) assign numbers called IP addresses to identify each Internet account. Most ISPs use dynamically assigned IP addresses. This means that the IP address can change at any time. You can use the IP address to access your network remotely, but most people don't know what their IP addresses are or when this number changes.

To make it easier to connect, you can get a free account with a Dynamic DNS service that lets you use a domain name to access your home network. To use this account, you must set up the router to use Dynamic DNS. Then the router notifies the Dynamic DNS service provider whenever its IP address changes. When you access your Dynamic DNS account, the service finds the current IP address of your home network and automatically connects you.

If your ISP assigns a private WAN IP address (such as 192.168.x.x or 10.x.x.x), the Dynamic DNS service does not work because private addresses are not routed on the Internet.

## Set up a new Dynamic DNS account

### To set up Dynamic DNS and register for a free NETGEAR account:

1. Launch a web browser from a computer or mobile device that is connected to your mesh network.
2. Enter **http://www.routerlogin.net**.  
A login window opens.
3. Enter the router admin user name and password.  
The user name is **admin**. The password is the one that you specified the first time that you logged in. The user name and password are case-sensitive.  
The BASIC Home page displays.
4. Select **ADVANCED > Advanced Setup > Dynamic DNS**.  
The Dynamic DNS page displays.
5. Select the **Use a Dynamic DNS Service** check box.
6. From the **Service Provider** menu, select **NETGEAR**.  
You can select another service provider.
7. Select the **No** radio button.
8. In the **Host Name** field, type the name that you want to use for your URL.  
The host name is sometimes called the domain name. Your free URL includes the host name that you specify and ends with mynetgear.com. For example, specify *MyName.mynetgear.com*.
9. In the **Email** field, type the email address for your account.
10. In the **Password (6-32 characters)** field, type the password for your account.
11. Click the **Register** button.
12. Follow the onscreen instructions to register for your NETGEAR Dynamic DNS service.

## Use a DNS account that you already created

If you already created a Dynamic DNS account with NETGEAR or No-IP, you can set up the router to use your account.

### To set up Dynamic DNS if you already created an account:

1. Launch a web browser from a computer or mobile device that is connected to your mesh network.
2. Enter **http://www.routerlogin.net**.

A login window opens.

3. Enter the router admin user name and password.  
The user name is **admin**. The password is the one that you specified the first time that you logged in. The user name and password are case-sensitive.  
The BASIC Home page displays.
4. Select **ADVANCED > Advanced Setup > Dynamic DNS**.  
The Dynamic DNS page displays.
5. Select the **Use a Dynamic DNS Service** check box.
6. From the **Service Provider** menu, select your provider.
7. Select the **Yes** radio button.  
The page adjusts and displays the **Show Status**, **Cancel**, and **Apply** buttons.
8. In the **Host Name** field, type the host name (sometimes called the domain name) for your DDNS account.
9. In the **Email** field, type the email address for your DDNS account.
10. In the **Password (6-32 characters)** field, type the password for your DDNS account.
11. Click the **Apply** button.  
Your settings are saved.
12. To verify that your Dynamic DNS service is enabled in the router, click the **Show Status** button.  
A message displays the Dynamic DNS status.

## Change the Dynamic DNS settings

You can change the settings for your Dynamic DNS account.

### To change your settings:

1. Launch a web browser from a computer or mobile device that is connected to your mesh network.
2. Enter **http://www.routerlogin.net**.  
A login window opens.
3. Enter the router admin user name and password.  
The user name is **admin**. The password is the one that you specified the first time that you logged in. The user name and password are case-sensitive.  
The BASIC Home page displays.

4. Select **ADVANCED > Advanced Setup > Dynamic DNS**.

The Dynamic DNS page displays.

5. Change your DDNS account settings as necessary.

6. Click the **Apply** button.

Your settings are saved.

## Manage the router configuration file

The configuration settings of the router are stored within the router in a configuration file. You can back up (save) this file to your computer, restore it, or reset it to the factory default settings.

### Back up the settings

#### To back up the 's configuration settings:

1. Launch a web browser from a computer or mobile device that is connected to your mesh network.

2. Enter **http://www.routerlogin.net**.

A login window opens.

3. Enter the router admin user name and password.

The user name is **admin**. The password is the one that you specified the first time that you logged in. The user name and password are case-sensitive.

The BASIC Home page displays.

4. Select **ADVANCED > Administration > Backup Settings**.

The Backup Settings page displays.

5. Click the **Back Up** button.

6. Follow the direction of your browser to save the file.

A copy of the current settings is saved in the location that you specified.

## Erase the settings on the router

**CAUTION:** This process erases all settings that you configured in the router.

### To erase the settings on the router

1. Launch a web browser from a computer or mobile device that is connected to your mesh network.
2. Enter **http://www.routerlogin.net**.  
A login window opens.
3. Enter the router admin user name and password.  
The user name is **admin**. The password is the one that you specified the first time that you logged in. The user name and password are case-sensitive.  
The BASIC Home page displays.
4. Select **ADVANCED > Administration > Backup Settings**.  
The Backup Settings page displays.
5. Click the **Erase** button.  
The configuration is reset to factory default settings. When the reset is complete, the router restarts. This process takes about two minutes.

**WARNING:** To avoid the risk of corrupting the firmware, do not interrupt the reset. For example, do not close the browser, click a link, or load a new page. Do not turn off the router. Wait until the router finishes restarting.

## Restore the settings

### To restore configuration settings that you backed up:

1. Launch a web browser from a computer or mobile device that is connected to your mesh network.
  2. Enter **http://www.routerlogin.net**.  
A login window opens.
  3. Enter the router admin user name and password.  
The user name is **admin**. The password is the one that you specified the first time that you logged in. The user name and password are case-sensitive.  
The BASIC Home page displays.
  4. Select **ADVANCED > Administration > Backup Settings**.
-

The Backup Settings page displays.

5. Click the **Browse** button to find and select the `.cfg` file.
6. Click the **Restore** button.

The file is uploaded to the router and the router restarts.

**WARNING:** Do not interrupt the restoration process.

## Return the router or satellite to its factory default settings

Under some circumstances (for example, if you lost track of the changes that you made to the router or satellite settings or you move the router to a different network), you might want to erase the configuration and reset the router or satellite to its factory default settings.

To reset the router or satellite to its factory default settings, you can use either the **Reset** button on the back of the router or satellite or the Erase function.

After you reset the router to factory default settings, the user name is admin, the password is password, the LAN IP address is 192.168.1.1 (which is the same as [www.routerlogin.net](http://www.routerlogin.net)), and the DHCP server is enabled.

**Note:** If the router is in access point mode or bridge mode and you do not know the IP address that is assigned to it, first try to use an IP scanner application to detect the IP address. (IP scanner applications are available online free of charge.) If you can detect the IP address, you don't need to reset the router to factory default settings.

### Use the Reset button

**CAUTION:** If you use the **Reset** button on the router, the process erases all settings that you configured on the router

#### To reset the router or satellite to factory default settings:

1. On the back of the router or satellite, locate the **Reset** button.
2. Using a straightened paper clip, press and hold the **Reset** button for at least five seconds.
3. Release the **Reset** button.

When the reset is complete, the router or satellite restarts. This process takes about two minutes.

**WARNING:** To avoid the risk of corrupting the firmware, do not interrupt the reset. Do not turn off the router or satellite. Wait until the router or satellite finishes restarting.

## Erase the settings on the router

**CAUTION:** This process erases all settings that you configured in the router.

### To erase the settings on the router

1. Launch a web browser from a computer or mobile device that is connected to your mesh network.
2. Enter **http://www.routerlogin.net**.  
A login window opens.
3. Enter the router admin user name and password.  
The user name is **admin**. The password is the one that you specified the first time that you logged in. The user name and password are case-sensitive.  
The BASIC Home page displays.
4. Select **ADVANCED > Administration > Backup Settings**.  
The Backup Settings page displays.
5. Click the **Erase** button.  
The configuration is reset to factory default settings. When the reset is complete, the router restarts. This process takes about two minutes.

**WARNING:** To avoid the risk of corrupting the firmware, do not interrupt the reset. For example, do not close the browser, click a link, or load a new page. Do not turn off the router. Wait until the router finishes restarting.

## Connect to your router with Anywhere Access

The Anywhere Access feature on the Nighthawk app allows you to connect to your router when you're away from home and change its settings. Before you can use the

---

## Nighthawk Tri-band Mesh WiFi 6

Anywhere Access feature on the Nighthawk app, you must update your router's firmware and download the latest Nighthawk app for your mobile device.

For more information about how to update your router's firmware, see [Update the router and satellite firmware](#) on page 92.

To download the latest Nighthawk app for your mobile device, visit <https://www.netgear.com/home/apps-services/nighthawk-app/>.

# 9

## Use OpenVPN to Access Your Network

---

You can use OpenVPN software to remotely access your router with virtual private networking (VPN). This chapter explains how to install and use OpenVPN software to set up a VPN tunnel.

The chapter contains the following sections:

- [About VPN connections](#)
- [Enable OpenVPN service in the router](#)
- [Install OpenVPN software on a VPN client](#)
- [LAN IP addressing in VPN networks](#)
- [Use VPN to access your Internet service at home](#)

# About VPN connections

A virtual private network (VPN) lets you use the Internet to securely access your network when you aren't home.

This type of VPN access is called a client-to-gateway tunnel. The computer is the client, and the router is the gateway. To use the VPN feature, you must do the following:

- Log in to the router to enable and configure OpenVPN (see [Enable OpenVPN service in the router](#) on page 116).
- Install OpenVPN client software and configuration files on your device from which you want to use VPN (see [Install OpenVPN software on a VPN client](#) on page 117).
- Run the OpenVPN client software on your device when you want to use a VPN connection.

Enabling OpenVPN on your router allows VPN connections between the router and a client, for example your laptop when you are away from home. The router provides the VPN service and the laptop is the VPN client. Traffic between the router and the laptop is encrypted.

**Note:** The router itself does not function as a VPN client to an external VPN service provider, so it does not encrypt traffic passing between your home network and the Internet.

VPN can use either Dynamic DNS (DDNS) or a static IP address to connect with your router:

- To use a DDNS service, register for a DDNS account with a host name. You use the host name to access your network. The router supports these DDNS accounts: NETGEAR, No-IP, and Dyn. For more information, see [Set up and manage Dynamic DNS](#) on page 106.
- If your Internet service provider (ISP) assigned a static WAN IP address that never changes, the VPN can use that IP address to connect to your home network.

# Enable OpenVPN service in the router

You must enable the OpenVPN service settings in the router before you can use a VPN connection.

## To enable OpenVPN service:

1. Launch a web browser from a computer or mobile device that is connected to your mesh network.
2. Enter **http://www.routerlogin.net**.  
A login window opens.
3. Enter the router user name and password.  
The user name is **admin**. The password is the one that you specified the first time that you logged in. The user name and password are case-sensitive.  
The BASIC Home page displays.
4. Select **ADVANCED > Advanced Setup > VPN Service**.  
The VPN page displays.

**Note:** The OpenVPN configuration software packages that you can download on the page are for the VPN client devices (see [Install OpenVPN software on a VPN client](#) on page 117).

5. Select the **Enable VPN Service** check box.  
We recommend that you use the default TUN mode and TAP mode settings. (These settings determine how VPN information is transferred.) If you know that you need other settings, you can change the TUN mode and TAP mode settings, but you must do so *before* you download and install the OpenVPN configuration software packages on client devices (see [Install OpenVPN software on a VPN client](#) on page 117).
6. To change the TUN mode settings, do the following:
  - To change the TUN mode service type, select the **UDP** or **TCP** radio button.  
The default protocol for TUN mode is UDP.
  - To change the TUN mode service port, type the port number that you want to use in the field.  
The default port number for TUN mode is 12973. The TUN port number is used in the `.ovpn` file of the OpenVPN configuration software package for Mac and non-Windows clients.

7. To change the TAP mode settings, do the following:
  - To change the TAP mode service type, select the **UDP** or **TCP** radio button. The default protocol for TAP mode is UDP.
  - To change the TAP mode service port, type the port number that you want to use in the field. The default port number for TAP mode is 12974. The TAP port number is used in the `.ovpn` file of the OpenVPN configuration software package for Windows clients.
8. Click the **Apply** button. Your changes are saved. VPN is enabled in the router, but you must install and set up OpenVPN software on your device before you can use a VPN connection.

## Install OpenVPN software on a VPN client

You must install OpenVPN software on each Windows-based computer, Mac computer, iOS device, and Android device that you plan to use for VPN connections to your router. Each computer or device is called a VPN client.

The software consists of the application software and the configuration files:

- Download and install the application software from the link that is provided in each client-specific section.
- Download and install the configuration files from the router as described in each client-specific section. The configuration files provide the correct router configuration information for the client utility. You must download the configuration files *after* you enable and configure OpenVPN service in the router (see [Enable OpenVPN service in the router](#) on page 116).

**Note:** If you later change the OpenVPN configuration in the router (for example, you change the TUN or TAP port number), you must download and install the `.ovpn` configuration file again on each client, depending on its operating system. If you change the TUN port number in the router, the `.ovpn` configuration file for Mac and non-Windows clients changes. If you change the TAP port number in the router, the `.ovpn` configuration file for Windows clients changes.

## Install OpenVPN software on a Windows-based computer

You must install both the OpenVPN client utility and OpenVPN configuration files on each Windows-based computer where you want to use a VPN connection to your router.

### To download and install the OpenVPN client utility and OpenVPN configuration files on a Windows-based computer:

1. To download the OpenVPN client utility on your Windows-based computer, visit [openvpn.net/community-downloads/](https://openvpn.net/community-downloads/).
2. Select the Windows package with the installer files.  
In most situations, you can download the Windows 32-bit or Windows 64-bit installer files, depending on your Windows operating system.
3. Download and install the OpenVPN client utility on your computer.  
You need to have administrative privileges.
4. Launch a web browser from a Windows-based computer that is connected to your mesh network.
5. Enter **http://www.routerlogin.net**.  
A login window opens.
6. Enter the router user name and password.  
The user name is **admin**. The password is the one that you specified the first time that you logged in. The user name and password are case-sensitive.  
The BASIC Home page displays.
7. Select **ADVANCED > Advanced Setup > VPN Service**.  
The VPN Service page displays.
8. Make sure that the **Enable VPN Service** check box is selected.  
For more information about the VPN configuration for the router, see [Enable OpenVPN service in the router](#) on page 116.
9. Click the **For Windows** button to download the router's OpenVPN configuration files to your Windows-based computer.
10. Unzip the OpenVPN configuration files and copy them to the folder in which you installed the OpenVPN client utility.
11. Modify the VPN interface name to **NETGEAR-VPN**:
  - a. If your computer is running Windows 10, select **Control Panel > Network and Sharing Center > Change adapter settings**.  
If your computer is running another Windows version, find the page that lets you change the adapter settings.
  - b. In the local area connection list, find the local area connection with the device name **TAP-Windows Adapter**.

- c. Select the local area connection and change its name (*not* its device name) to **NETGEAR-VPN**.

If you do not change the VPN interface name, the VPN tunnel connection will fail.

You can now open a VPN tunnel to the router.

For more information about installing and using OpenVPN on your Windows-based computer, visit <https://openvpn.net/community-resources/how-to/#quick>.

## Install OpenVPN software on a Mac computer

You must install both the Tunnelblick OpenVPN client utility and OpenVPN configuration files on each Mac computer where you want to use a VPN connection to your router.

### **To download and install the Tunnelblick OpenVPN client utility and OpenVPN configuration files on a Mac computer:**

1. To download the Tunnelblick OpenVPN client utility on your Mac computer, visit <https://tunnelblick.net/downloads.html>.
2. Download and install the Tunnelblick OpenVPN client utility on your Mac computer. You need to have administrative privileges.
3. Launch a web browser from the Mac computer, which must be connected to your mesh network.
4. Enter **http://www.routerlogin.net**.  
A login window opens.
5. Enter the router user name and password.  
The user name is **admin**. The password is the one that you specified the first time that you logged in. The user name and password are case-sensitive.  
The BASIC Home page displays.
6. Select **ADVANCED > Advanced Setup > VPN Service**.  
The VPN Service page displays.
7. Make sure that the **Enable VPN Service** check box is selected.  
For more information about the VPN configuration for the router, see [Enable OpenVPN service in the router](#) on page 116.
8. Click the **For non-Windows** button to download the router's OpenVPN configuration files to your Mac computer.
9. Unzip the OpenVPN configuration files and copy them to the folder in which you installed the Tunnelblick OpenVPN client utility.

You can now open a VPN tunnel to the router.

For more information about installing and using OpenVPN on your Mac computer, visit <https://openvpn.net/vpn-server-resources/installation-guide-for-openvpn-connect-client-on-macos/>.

## Install OpenVPN software on an iOS device

You must install both the OpenVPN Connect app and OpenVPN configuration files on each iOS device where you want to use a VPN connection to your router.

### To download and install the OpenVPN Connect app and OpenVPN configuration files on an iOS device:

1. On your iOS device, download and install the OpenVPN Connect app from the Apple app store.
2. Launch a web browser from a computer or your iOS device that is connected to your mesh network.
3. Enter **http://www.routerlogin.net**.  
A login window opens.
4. Enter the router user name and password.  
The user name is **admin**. The password is the one that you specified the first time that you logged in. The user name and password are case-sensitive.  
The BASIC Home page displays.
5. Select **ADVANCED > Advanced Setup > VPN Service**.  
The VPN Service page displays.
6. Make sure that the **Enable VPN Service** check box is selected.  
For more information about the VPN configuration for the router, see [Enable OpenVPN service in the router](#) on page 116.
7. Click the **For Smart Phone** button to download the router's OpenVPN configuration files to your computer or iOS device.  
If you download the configuration files to your computer, unzip the files, and send them your iOS device.
8. On your iOS device, do the following:
  - a. Open the `.ovpn` file.
  - b. If the OpenVPN Connect app does not start automatically, a list of apps might display: Select the OpenVPN Connect app.
  - c. Install the `.ovpn` file.

You can now open a VPN tunnel to the router.

For more information about installing and using OpenVPN on your iOS device, visit [https://www.vpngate.net/en/howto\\_openvpn.aspx#ios](https://www.vpngate.net/en/howto_openvpn.aspx#ios).

## Install OpenVPN software on an Android device

You must install both the OpenVPN Connect app and OpenVPN configuration files on each Android device where you want to use a VPN connection to your router.

### To download and install the OpenVPN Connect app and OpenVPN configuration files on an Android device:

1. On your Android device, download and install the OpenVPN Connect app from the Google Play Store.
2. Launch a web browser from a computer or your Android device that is connected to your mesh network.
3. Enter **<http://www.routerlogin.net>**.  
A login window opens.
4. Enter the router user name and password.  
The user name is **admin**. The password is the one that you specified the first time that you logged in. The user name and password are case-sensitive.  
The BASIC Home page displays.
5. Select **ADVANCED > Advanced Setup > VPN Service**.  
The VPN Service page displays.
6. Make sure that the **Enable VPN Service** check box is selected.  
For more information about the VPN configuration for the router, see [Enable OpenVPN service in the router](#) on page 116.
7. Click the **For Smart Phone** button to download the router's OpenVPN configuration files to your computer or Android device.  
If you download the configuration files to your computer, unzip the files, and send them your Android device.
8. On your Android device, open the .ovpn file and import it into the OpenVPN Connect app.

You can now open a VPN tunnel to the router.

For more information about using OpenVPN on your Android device, visit [https://www.vpngate.net/en/howto\\_openvpn.aspx#android](https://www.vpngate.net/en/howto_openvpn.aspx#android).

# LAN IP addressing in VPN networks

For the VPN connection to work, your computer or device (the VPN client) must be connected to a network that uses a different LAN IP address scheme than your router.

The default LAN IP address scheme for the router is 192.168.1.x. (The most common IP schemes are 192.168.x.x, 172.x.x.x, and 10.x.x.x.) If you experience a conflict, change the IP scheme either for your home network or for the network where your VPN client device is connected.

If both networks use the same LAN IP scheme, when the VPN tunnel is established, you cannot access your home router or your home network with the OpenVPN software.

For information about changing the LAN settings on the router, see [Change the LAN IP address settings](#) on page 76.

## Use VPN to access your Internet service at home

When you're away from home and you access the Internet, you usually use a local Internet service provider. For example, at a coffee shop you might be given a code that lets you use the coffee shop's Internet service account to surf the web.

Your router lets you use a VPN connection to access your own Internet service when you're away from home. You might want to do this if you travel to a geographic location that doesn't support all the Internet services that you use at home. For example, your Netflix account might work at home but not in a different country.

### Allow VPN client Internet access in the router

By default, the router is set up to allow VPN connections only to your home network, but you can change the settings to allow Internet access. Accessing the Internet remotely through a VPN might be slower than accessing the Internet directly.

#### **To allow VPN clients to use your home Internet service:**

1. Launch a web browser from a computer or mobile device that is connected to your mesh network.
2. Enter **http://www.routerlogin.net**.  
A login window opens.
3. Enter the router user name and password.

The user name is **admin**. The password is the one that you specified the first time that you logged in. The user name and password are case-sensitive.

The BASIC Home page displays.

4. Select **ADVANCED > Advanced Setup > VPN Service**.

The VPN Service page displays.

5. Make sure that the **Enable VPN Service** check box is selected.

For more information about the VPN configuration for the router, see [Enable OpenVPN service in the router](#) on page 116.

6. Scroll down to the Clients will use this VPN connection to access section, and select the **All sites on the Internet & Home Network** radio button.

When you access the Internet with the VPN connection, instead of using a local Internet service, you use the Internet service from your home network.

7. Click the **Apply** button.

Your settings are saved.

## Block VPN client Internet access in the router

By default, the router is set up to allow VPN connections only to your home network, not to the Internet service for your home network. If you changed this setting to allow Internet access, you can change it back.

### **To allow VPN clients to access only your home network and block them from using the Internet service for your home network:**

1. Launch a web browser from a computer or mobile device that is connected to your mesh network.

2. Enter **http://www.routerlogin.net**.

A login window opens.

3. Enter the router user name and password.

The user name is **admin**. The password is the one that you specified the first time that you logged in. The user name and password are case-sensitive.

The BASIC Home page displays.

4. Select **ADVANCED > Advanced Setup > VPN Service**.

The VPN Service page displays.

5. Make sure that the **Enable VPN Service** check box is selected.

For more information about the VPN configuration for the router, see [Enable OpenVPN service in the router](#) on page 116.

6. Scroll down to the Clients will use this VPN connection to access section, and select the **Home Network only** radio button.

This is the default setting. The VPN connection is only to your home network, not to the Internet service for your home network.

7. Click the **Apply** button.  
Your settings are saved.

# 10

## Manage Port Forwarding and Port Triggering

---

You can use port forwarding and port triggering to set up rules for Internet traffic. You need networking knowledge to set up these features.

This chapter contains the following sections:

- [Manage port forwarding to a local server](#)
- [Port triggering](#)

# Manage port forwarding to a local server

If your home network includes a server, you can allow certain types of incoming traffic to reach the server. For example, you might want to make a local web server, FTP server, or game server visible and available to the Internet.

The router can forward incoming traffic with specific protocols to computers on your local network. You can specify the servers for applications and you can also specify a default DMZ server to which the router forwards all other incoming protocols.

## Set up port forwarding to a local server

### To forward specific incoming protocols:

1. Decide which type of service, application, or game you want to provide.
2. Find the local IP address of the computer on your network that will provide the service.  
The server computer must always use the same IP address.
3. Assign the server computer a reserved IP address.  
See [Manage reserved LAN IP addresses](#) on page 80.
4. Launch a web browser from a computer or mobile device that is connected to your mesh network.
5. Enter **http://www.routerlogin.net**.  
A login window opens.
6. Enter the router user name and password.  
The user name is **admin**. The password is the one that you specified the first time that you logged in. The user name and password are case-sensitive.  
The BASIC Home page displays.
7. Select **ADVANCED > Advanced Setup > Port Forwarding/Port Triggering**.  
The Port Forwarding / Port Triggering page displays.
8. Leave the **Port Forwarding** radio button selected as the service type.
9. From the **Service Name** menu, select the service name.  
If the service that you want to add is not in the menu, create a custom service. See [Add a custom port forwarding service](#) on page 127.
10. In the **Server IP Address** field, enter the IP address of the computer that will provide the service.

11. Click the **Add** button.

The service displays in the menu.

## Add a custom port forwarding service

The router lists default services and applications that you can use in port forwarding rules. If the service or application is not predefined, you can add a port forwarding rule with a custom service or application.

### To add a custom service:

1. Find out which port number or range of numbers the application uses.  
You can usually find this information by contacting the publisher of the application or user groups or news groups.
2. Launch a web browser from a computer or mobile device that is connected to your mesh network.
3. Enter **http://www.routerlogin.net**.  
A login window opens.
4. Enter the router user name and password.  
The user name is **admin**. The password is the one that you specified the first time that you logged in. The user name and password are case-sensitive.  
The BASIC Home page displays.
5. Select **ADVANCED > Advanced Setup > Port Forwarding/Port Triggering**.  
The Port Forwarding / Port Triggering page displays.
6. Leave the **Port Forwarding** radio button selected as the service type.
7. Click the **Add Custom Service** button.  
The Ports - Custom Service page displays.
8. In the **Service Name** field, enter a descriptive name.
9. From the **Protocol** menu, select the protocol.  
If you are unsure, select **TCP/UDP**.
10. In the **External port range** field enter the port range.
11. Specify the internal ports by one of these methods:
  - Leave the **Use the same port range for Internal port** check box selected.
  - Type the port numbers in the **Internal Starting Port** field and the **Internal Ending Port** field.

You can enter a port range and fixed ports in one rule, for example, external (30-50, 78, 100-102), internal (40-60, 99, 200-202). With this rule, external ports 30-50 are forwarded to internal ports 40-60.

12. In the **Internal IP address** field, type the IP address or select the radio button for an attached device listed in the table.
13. Click the **Apply** button.  
The service is now in the list on the Port Forwarding/Port Triggering page.

## Change a port forwarding service

### To edit a port forwarding entry:

1. Launch a web browser from a computer or mobile device that is connected to your mesh network.
2. Enter **http://www.routerlogin.net**.  
A login window opens.
3. Enter the router user name and password.  
The user name is **admin**. The password is the one that you specified the first time that you logged in. The user name and password are case-sensitive.  
The BASIC Home page displays.
4. Select **ADVANCED > Advanced Setup > Port Forwarding/Port Triggering**.  
The Port Forwarding / Port Triggering page displays.
5. Leave the **Port Forwarding** radio button selected as the service type.
6. In the table, select the radio button next to the service name.
7. Click the **Edit Service** button.  
The Ports - Custom Services page displays.
8. Change the settings as needed.
9. Click the **Apply** button.  
Your settings are saved.

## Delete a port forwarding entry

### To delete a port forwarding entry:

1. Launch a web browser from a computer or mobile device that is connected to your mesh network.
2. Enter **http://www.routerlogin.net**.  
A login window opens.
3. Enter the router admin user name and password.  
The user name is **admin**. The password is the one that you specified the first time that you logged in. The user name and password are case-sensitive.  
The BASIC Home page displays.
4. Select **ADVANCED > Advanced Setup > Port Forwarding/Port Triggering**.  
The Port Forwarding / Port Triggering page displays.
5. Leave the **Port Forwarding** radio button selected.
6. In the table, select the radio button next to the service name.
7. Click the **Delete Service** button.  
The service is deleted.

## Application example: Make a local web server public

If you host a web server on your local network, you can use port forwarding to allow web requests from anyone on the Internet to reach your web server.

### To make a local web server public:

1. Assign your web server either a fixed IP address or a dynamic IP address using DHCP address reservation.  
In this example, your router always gives your web server an IP address of 192.168.1.33.
2. On the Port Forwarding/Port Triggering page, configure the router to forward the HTTP service to the local address of your web server at **192.168.1.33**.  
HTTP (port 80) is the standard protocol for web servers.
3. (Optional) Register a host name with a Dynamic DNS service and specify that name on the Dynamic DNS page of the router.  
Dynamic DNS makes it much easier to access a server from the Internet because you can type the name in the Internet browser. Otherwise, you must know the IP address that the ISP assigned, which typically changes.

## How the router implements the port forwarding rule

The following sequence shows the effects of a port forwarding rule:

1. When you type the URL `www.example.com` in your browser, the browser sends a web page request message with the following destination information:
  - **Destination address.** The IP address of `www.example.com`, which is the address of your router.
  - **Destination port number.** 80, which is the standard port number for a web server process.
2. Your router receives the message and finds your port forwarding rule for incoming port 80 traffic.
3. The router changes the destination in the message to IP address 192.168.1.33 and sends the message to that computer.
4. Your web server at IP address 192.168.1.33 receives the request and sends a reply message to your router.
5. Your router performs Network Address Translation (NAT) on the source IP address and sends the reply through the Internet to the computer or WiFi device that sent the web page request.

## Port triggering

Port triggering is a dynamic extension of port forwarding that is useful in these cases:

- An application must use port forwarding to more than one local computer (but not simultaneously).
- An application must open incoming ports that are different from the outgoing port.

With port triggering, the router monitors traffic to the Internet from an outbound “trigger” port that you specify. For outbound traffic from that port, the router saves the IP address of the computer that sent the traffic. The router temporarily opens the incoming port or ports that you specify in your rule and forwards that incoming traffic to that destination.

Port forwarding creates a static mapping of a port number or range of ports to a single local computer. Port triggering can dynamically open ports to any computer when needed and close the ports when they are no longer needed.

**Note:** If you use applications such as multiplayer gaming, peer-to-peer connections, real-time communications such as instant messaging, or remote assistance (a feature in Windows XP), enable Universal Plug and Play (UPnP).

## Add a port triggering service

### To add a port triggering service:

1. Launch a web browser from a computer or mobile device that is connected to your mesh network.
2. Enter **http://www.routerlogin.net**.  
A login window opens.
3. Enter the router admin user name and password.  
The user name is **admin**. The password is the one that you specified the first time that you logged in. The user name and password are case-sensitive.  
The BASIC Home page displays.
4. Select **ADVANCED > Advanced Setup > Port Forwarding/Port Triggering**.  
The Port Forwarding / Port Triggering page displays.
5. Select the **Port Triggering** radio button.  
The page adjusts.
6. Click the **Add Service** button.  
The Port Triggering - Services page displays.
7. In the **Service Name** field, type a descriptive service name.
8. From the **Service User** menu, select a user option:
  - **Any**: This is the default setting and allows any computer on the Internet to use this service.
  - **Single address**: Restricts the service to a particular computer. Enter the IP address in the fields, which become available with this selection from the menu.
9. From the **Service Type** menu, select the protocol (**TCP** or **UDP**) that is associated with the service or application.
10. In the **Triggering Port** field, enter the number of the outbound traffic port that must open the inbound ports.
11. From the **Connection Type** menu, select the protocol (**TCP** or **UDP**) that is associated with the inbound connection.  
If you are unsure, select **TCP/UDP**.
12. In the **Starting Port** and **Ending Port** fields, enter the enter the numbers of the inbound traffic ports.
13. Click the **Apply** button.

The service is now in the Portmap Table. You must enable port triggering before the router uses port triggering. See [Enable port triggering](#) on page 132.

## Enable port triggering

### To enable port triggering:

1. Launch a web browser from a computer or mobile device that is connected to your mesh network.
2. Enter **http://www.routerlogin.net**.  
A login window opens.
3. Enter the router admin user name and password.  
The user name is **admin**. The password is the one that you specified the first time that you logged in. The user name and password are case-sensitive.  
The BASIC Home page displays.
4. Select **ADVANCED > Advanced Setup > Port Forwarding/Port Triggering**.  
The Port Forwarding/Port Triggering page displays.
5. Select the **Port Triggering** radio button.
6. Clear the **Disable Port Triggering** check box.  
If this check box is selected, the router does not use port triggering even if you specified port triggering settings.
7. In the **Port Triggering Timeout** field, enter a value up to 9999 minutes.  
This value controls how long the inbound ports stay open when the router detects no activity. This value is required because the router cannot detect when the application terminates.
8. Click the **Apply** button.  
Your settings are saved.

## Application example: Port triggering for Internet Relay Chat

Some application servers, such as FTP and IRC servers, send replies to multiple port numbers. Using port triggering, you can tell the router to open more incoming ports when a particular outgoing port starts a session.

An example is Internet Relay Chat (IRC). Your computer connects to an IRC server at destination port 6667. The IRC server not only responds to your originating source port but also sends an "identify" message to your computer on port 113. Using port triggering,

you can tell the router, “When you initiate a session with destination port 6667, you must also allow incoming traffic on port 113 to reach the originating computer.” The following sequence shows the effects of this port triggering rule:

1. You open an IRC client program to start a chat session on your computer.
2. Your IRC client composes a request message to an IRC server using a destination port number of 6667, the standard port number for an IRC server process. Your computer then sends this request message to your router.
3. Your router creates an entry in its internal session table describing this communication session between your computer and the IRC server. Your router stores the original information, performs Network Address Translation (NAT) on the source address and port, and sends this request message through the Internet to the IRC server.
4. Noting your port triggering rule and observing the destination port number of 6667, your router creates another session entry to send any incoming port 113 traffic to your computer.
5. The IRC server sends a return message to your router using the NAT-assigned source port (for example, port 33333) as the destination port and sends an “identify” message to your router with destination port 113.
6. When your router receives the incoming message to destination port 33333, it checks its session table to see if a session is active for port number 33333. Finding an active session, the router restores the original address information replaced by NAT and sends this reply message to your computer.
7. When your router receives the incoming message to destination port 113, it checks its session table and finds an active session for port 113 associated with your computer. The router replaces the message’s destination IP address with your computer’s IP address and forwards the message to your computer.
8. When you finish your chat session, your router eventually senses a period of inactivity in the communications. The router then removes the session information from its session table and incoming traffic is no longer accepted on port numbers 33333 or 113.

# 11

## Troubleshooting

---

This chapter provides information to help you diagnose and solve problems you might experience with your router or satellite. If you do not find the solution here, check the NETGEAR support site at [netgear.com/support](https://netgear.com/support) for product and contact information.

This chapter includes the following sections:

- [Quick tips](#)
- [The router and satellite do not sync](#)
- [Cannot log in to the router](#)
- [Cannot access the Internet](#)
- [Troubleshoot Internet browsing](#)
- [Troubleshoot PPPoE](#)
- [Troubleshoot WiFi connectivity](#)
- [Troubleshoot your network using the ping utility](#)

## Quick tips

This section describes tips for troubleshooting some common problems.

### Sequence to restart your network

When you restart your network, follow this sequence:

1. Turn off *and* unplug the modem.
2. Turn off the router.
3. Plug in the modem and turn it on. Wait two minutes.
4. Turn on the router and wait two minutes.

### WiFi settings

Make sure that the WiFi settings in the WiFi-enabled computer or mobile device and the router match.

The WiFi network name (SSID) and WiFi security settings must match exactly.

If you set up an access list, you must add each WiFi-enabled computer or mobile device's MAC address to the router's access list.

### Network settings

Make sure that the network settings of the computer are correct. Wired and wirelessly connected computers must use network (IP) addresses on the same network as the router. The simplest way to do this is to configure each computer to obtain an IP address automatically using DHCP.

Some cable modem service providers require you to use the MAC address of the computer initially registered on the account. You can view the MAC address on the Attached Devices page.

## The router and satellite do not sync

If you are experiencing difficulty syncing the router and the satellite, we recommend that you move the satellite into the same room as the router during the sync. Then move the satellite to a different location.

### To sync the router and the satellite:

1. Place the satellite in the same room as the router.  
Use this satellite location only during the sync process.
2. Connect the satellite to a power source.
3. Press the **Sync** button on the router and then within two minutes, press the **Sync** button on the satellite.
4. Wait for the satellite LED to light.  
The satellite LED blinks white while it attempts to sync with the router. After the LED blinks white, it lights one of the following colors:
  - **Blue.** The router and satellite successfully synced, and the connection between the router and satellite is good.
  - **Amber.** The router and satellite failed to sync. Try repeating Step 3 again. If the sync keeps failing, try moving the satellite to a different location that's closer to the router.
5. Move the satellite to a new location and connect the satellite to a power source.
6. At the new location, check the satellite LED and make sure it lights blue.  
If the satellite LED lights blue, the satellite synced successfully. If the satellite LED lights amber, move the satellite closer to the router and try again. The satellite must be within range of the router's WiFi cover area for a good connection to the router.

## Cannot log in to the router

Make sure that your computer or mobile device is connected to your mesh WiFi network. If you do not want to use a WiFi connection, you can connect your computer to the router with an Ethernet cable.

If you changed the admin password and you forgot what it is, see [Reset the admin password](#) on page 97.

# Cannot access the Internet

Check your network and Internet connections:

1. Make sure that your WiFi-enabled computer or mobile device is connected to your mesh network.
2. If you are connected to your mesh network but you cannot access the Internet, check to see if your Internet connection is working.
3. Launch a web browser from a computer or WiFi device that is connected to the network.
4. Enter **http://www.routerlogin.net**.  
A login window opens.
5. Enter the router admin user name and password.  
The user name is **admin**. The password is the one that you specified the first time that you logged in. The user name and password are case-sensitive.  
The BASIC Home page displays.
6. Click the **ADVANCED** tab.  
The ADVANCED Home page displays.
7. Check that an IP address is shown for the Internet port.

If 0.0.0.0 is shown, your router did not obtain an IP address from your Internet service provider (ISP).

If your router cannot obtain an IP address from the ISP, you can force your cable or DSL modem to recognize your new router by restarting your network. For more information, see [Sequence to restart your network](#) on page 135.

If your router is still unable to obtain an IP address from the ISP, the problem might be one of the following:

- Your Internet service provider (ISP) might require a login program. Ask your ISP whether they require PPP over Ethernet (PPPoE) or some other type of login.
- If your ISP requires a login, the login name and password might be set incorrectly.

- Your ISP might check for your computer's host name. Assign the computer host name of your ISP account as the account name on the Internet Setup page.
- If your ISP allows only one Ethernet MAC address to connect to Internet and checks for your computer's MAC address, do one of the following:
  - Inform your ISP that you bought a new network device and ask them to use the router's MAC address.
  - Configure your router to clone your computer's MAC address.

## Troubleshoot Internet browsing

If your router can obtain an IP address but your computer is unable to load any web pages from the Internet, it might be for one of the following reasons:

- The traffic meter is enabled, and the limit was reached.  
By configuring the traffic meter not to block Internet access when the traffic limit is reached, you can resume Internet access. If your ISP sets a usage limit, they might charge you for the overage.
- Your computer might not recognize any DNS server addresses. A DNS server is a host on the Internet that translates Internet names (such as www addresses) to numeric IP addresses.  
Typically, your ISP provides the addresses of one or two DNS servers for your use. If you entered a DNS address during the router's configuration, restart your computer. Alternatively, you can configure your computer manually with a DNS address, as explained in the documentation for your computer.
- The router might not be configured as the default gateway on your computer. Reboot the computer and verify that the router address ([www.routerlogin.net](http://www.routerlogin.net)) is listed by your computer as the default gateway address.
- You might be running login software that is no longer needed. If your ISP provided a program to log you in to the Internet, you no longer need to run that software after installing your router.

# Troubleshoot PPPoE

If you are using PPPoE, try troubleshooting your Internet connection.

## To troubleshoot a PPPoE connection:

1. Launch a web browser from a computer or WiFi device that is connected to the network.
2. Enter **http://www.routerlogin.net**.  
A login window opens.
3. Enter the router admin user name and password.  
The user name is **admin**. The password is the one that you specified the first time that you logged in. The user name and password are case-sensitive.  
The BASIC Home page displays.
4. Click the **ADVANCED** tab.  
The ADVANCED Home page displays.
5. In the Internet Port pane, click the **Connection Status** button.  
The Connection Status window opens.
6. Check the Connection Status window to see if your PPPoE connection is active and working.  
If the router is not connected, click the **Connect** button.  
The router continues to attempt to connect indefinitely.
7. If you cannot connect after several minutes, the router might be set up with an incorrect service name, user name, or password, or your ISP might be experiencing a provisioning problem.  
Unless you connect manually, the router does not authenticate using PPPoE until data is transmitted to the network.

# Troubleshoot WiFi connectivity

If you are experiencing trouble connecting to your mesh WiFi network, try to isolate the problem:

- Does the WiFi-enabled computer or mobile device that you are using find your WiFi network?

If you disabled the router's SSID broadcast, then your WiFi network is hidden and does not display in the list of networks that your computer or WiFi device finds. (By default, SSID broadcast is enabled.)

- Does your WiFi-capable device support the security that you are using for your WiFi network (WPA2 or WPA3)?
- To view the WiFi settings for the router, use an Ethernet cable to connect a computer to the Ethernet port on the router. Then log in to the router, and select **BASIC > Wireless**.

**Note:** Be sure to click the **Apply** button if you change settings.

- If you are trying to connect to the 5 GHz WiFi band, does your WiFi-enabled computer or mobile device support this standard?
- Did your computer or WiFi device automatically connect to a different WiFi network in your area, such as a WiFi hotspot?

## Troubleshoot your network using the ping utility

Most network devices and routers contain a ping utility that sends an echo request packet to the designated device. The device then responds with an echo reply. You can easily troubleshoot a network using the ping utility in your computer or workstation.

### Test the LAN path from a Windows-based computer to your router

You can ping the router from your Windows-based computer to verify that the LAN path to your router is set up correctly.

#### To ping the router from your Windows-based computer:

1. From the Windows toolbar, click the **Start** button and select **Run**.
2. In the field provided, type **ping** followed by the IP address of the router, as in this example:  
**ping www.routerlogin.net**
3. Click the **OK** button.

You should see a message like this one:

*Pinging <IP address > with 32 bytes of data*

---

If the path is working, you see this message:

```
Reply from <IP address >: bytes=32 time=NN ms TTL=xxx
```

If the path is not working, you see this message:

```
Request timed out
```

If the path is not functioning correctly, you might be experiencing one of the following problems:

- Wrong physical connections  
Check that the appropriate LEDs are on for your network devices. If your router and computer are connected to a separate Ethernet switch, make sure that the link LEDs on the switch are lit for the switch ports that your computer and router are connected to.
- Wrong network configuration  
Verify that the IP address for your router and your computer are correct and that the addresses are on the same subnet.

## Test the path from a Windows-based computer to a remote device

After verifying that the LAN path works correctly, test the path from your Windows-based computer to a remote device.

### To test the path from your Windows-based computer to a remote device:

1. From the Windows toolbar, click the **Start** button and select **Run**.
2. In the Windows Run window, type:  
**ping -n 10 <IP address>**  
where <IP address> is the IP address of a remote device such as your ISP DNS server.

If the path is functioning correctly, messages display that are similar to those shown in [Test the LAN path from a Windows-based computer to your router](#) on page 140.

If you do not receive replies, check the following:

- Check to see that the IP address of your router is listed as the default gateway for your computer. If DHCP assigns the IP configuration of your computers, this information is not visible in your computer Network Control Panel. Verify that the IP address of the router is listed as the default gateway.
- Check to see that the network address of your computer (the portion of the IP address specified by the subnet mask) is different from the network address of the remote device.
- Check to see that your cable or DSL modem is connected and functioning.

## Nighthawk Tri-band Mesh WiFi 6

- If your ISP assigned a host name to your computer, enter that host name as the account name on the Internet Setup page.
- Your ISP might be rejecting the Ethernet MAC addresses of all but one of your computers.

Many broadband ISPs restrict access by allowing traffic only from the MAC address of your broadband modem. Some ISPs additionally restrict access to the MAC address of a single computer connected to that modem. If your ISP does this, configure your router to “clone” or “spoof” the MAC address from the authorized computer.

# 12

## Supplemental Information

---

This appendix covers the following topics:

- [Factory settings](#)
- [Technical specifications](#)

# Factory settings

You can return your router or satellite to its factory settings. Use the end of a paper clip or a similar object to press and hold the **Reset** button on the back of the router or satellite for at least seven seconds until the router or satellite LED blinks. The router or satellite resets, and returns to the factory settings.

## Factory settings for router model MR80

The following table shows the factory default settings for the router.

Table 4. Factory default settings for the router

Feature	Default Setting	
Router login	User login URL	http://www.routerlogin.net
	User name (case-sensitive)	admin
Internet connection	WAN MAC address	Use default hardware address
	WAN MTU size	1500
	Port speed	AutoSensing
Local network (LAN)	LAN IP	192.168.1.1
	Subnet mask	255.255.255.0
	DHCP server	Enabled
	DHCP range	192.168.1.2 to 192.168.1.254
	DHCP starting IP address	192.168.1.2
	DHCP ending IP address	192.168.1.254
	DMZ	Disabled
	Time zone	GMT for WW GMT -8 for NA and CN GMT +10 for AU GMT +9 for KO GMT +8 for PR GMT +5:30 for IN
Time zone adjusted for daylight saving time	Disabled	

Table 4. Factory default settings for the router (Continued)

Feature	Default Setting	
Firewall	Inbound (communications coming in from the Internet)	Disabled
	Outbound (communications going out to the Internet)	Enabled (all)
	Source MAC filtering	Disabled
WiFi	WiFi communication	Enabled
	SSID name	See router label
	Security	WPA2-PSK (AES)
	Broadcast SSID	Enabled
	Transmission speed	Auto <sup>1</sup>
	Country/region	United States of America; otherwise, varies by region
	RF channel 2.4 GHz	Auto
	RF channel 5 GHz	Fronthaul: Channel 44 Backhaul: <ul style="list-style-type: none"> <li>• Channel 153 for NA, PR, AU, CA, and TW</li> <li>• Channel 108 for EU, KO, and IN</li> </ul>

<sup>1</sup>Maximum wireless signal rate derived from IEEE Standard 802.11 specifications. Actual throughput can vary. Network conditions and environmental factors, including volume of network traffic, building materials and construction, and network overhead, lower actual data throughput rate.

## Factory settings for satellite model MS80

The following table shows the factory default settings for the satellite.

Table 5. Factory default settings for the satellite

Feature	Default Setting	
Router login	User login URL	<a href="http://www.routerlogin.net">http://www.routerlogin.net</a>
	User name (case-sensitive)	admin
	Login password (case-sensitive)	password



## Nighthawk Tri-band Mesh WiFi 6

Table 5. Factory default settings for the satellite (Continued)

Feature	Default Setting	
Internet connection	WAN MAC address	Use default hardware address
	WAN MTU size	1500
	Port speed	AutoSensing
Local network (LAN)	LAN IP	192.168.1.250
	Subnet mask	255.255.255.0
	DHCP server	Disabled
	DMZ	Disabled
	Time zone	GMT for WW GMT -8 for NA and CN GMT +10 for AU GMT +9 for KO GMT +8 for PR GMT +5:30 for IN
	Time zone adjusted for daylight saving time	Disabled
	SNMP	Disabled
WiFi	WiFi communication	Enabled
	SSID name	See satellite label
	Security	WPA2-PSK (AES)
	Broadcast SSID	Enabled
	Transmission speed	Auto <sup>2</sup>
	Country/region	United States of America; otherwise, varies by region
	RF channel 2.4 GHz	Auto
	RF channel 5 GHz	Fronthaul: Channel 44 Backhaul: <ul style="list-style-type: none"> <li>• Channel 153 for NA, PR, AU, CA, and TW</li> <li>• Channel 108 for EU, KO, and IN</li> </ul>

<sup>2</sup>Maximum wireless signal rate derived from IEEE Standard 802.11 specifications. Actual throughput can vary. Network conditions and environmental factors, including volume of network traffic, building materials and construction, and network overhead, lower actual data throughput rate.



# Technical specifications

The following are the technical specifications for your router and satellite

## Technical specifications for router model MR80

The following table shows the technical specifications for the router.

Table 6. Technical specifications for the router

Feature	Description
Data and routing protocols	TCP/IP, RIP-1, RIP-2, DHCP, PPPoE, PPTP, Bigpond, Dynamic DNS, UPnP, and SMB
Power adapter	North America: 120V, 60 Hz, input UK, Australia: 240V, 50 Hz, input Europe: 230V, 50 Hz, input All regions (output): 12V, 2.5A DC output
Dimensions	5.51 x 5.51 x 3.62 in (140 x 140 x 92 mm)
Weight	1.4 lb (639 g)
Operating temperature	0° to 35°C (32° to 95°F)
Operating humidity	90% maximum relative humidity, noncondensing
Electromagnetic emissions	FCC Part 15, Subpart B, Class B IECS-003, Class B EN 55032, EN 55035, Class B AS/NZS CISPR 32, Class B
LAN	RJ-45 port supporting 10BASE-T, 100BASE-TX, and 1000BASE-T
Internet (WAN)	RJ-45 port supporting 10BASE-T, 100BASE-TX, and 1000BASE-T
WiFi	Maximum wireless signal rate complies with the IEEE 802.11 standard. <sup>3</sup>
Radio data rates	2.4 GHz: Max 600 Mbps 5 GHz Front haul: Max 1200 Mbps 5 GHz Back haul: Max 1800 Mbps
Data encoding standards	IEEE 802.11b/g/n 2.4 GHz-1024 QAM support IEEE 802.11 a/n/ac 5 GHz-1024 QAM support



Table 6. Technical specifications for the router (Continued)

Feature	Description
Maximum number of computers per wireless network	Limited by the amount of WiFi network traffic generated by each node (typically 50-70 nodes) 2.4 GHz: 127 5 GHz (front haul): 127
Operating frequency range	2.4 GHz: <ul style="list-style-type: none"> <li>• 2.412-2.462 GHz (US)</li> <li>• 2.412-2.472 GHz (Europe ETSI)</li> </ul> 5 GHz: <ul style="list-style-type: none"> <li>• 5.18 GHz-5.24 GHz and 5.745 GHz-5.825 GHz (US)</li> <li>• 5.18 GHz-5.24 GHz and 5.5 GHz-5.7 GHz (Europe)</li> <li>• 5.26 GHz-5.32 GHz (Europe)</li> </ul>
802.11 security	WPA-PSK [TKIP], WPA2-PSK [AES], WPA3-Personal

<sup>3</sup> *Maximum wireless signal rate derived from IEEE Standard 802.11 specifications. Actual throughput can vary. Network conditions and environmental factors, including volume of network traffic, building materials and construction, and network overhead, lower actual data throughput rate.*

## Technical specifications for satellite model MS80

The following table shows the technical specifications for the satellite.

Table 7. Technical specifications for the satellite

Feature	Description
Data and routing protocols	TCP/IP
Power adapter	North America: 120V, 60 Hz, input UK, Australia: 240V, 50 Hz, input Europe: 230V, 50 Hz, input All regions (output): 12V, 1A DC output
Dimensions	5.51 x 5.51 x 3.62 in (140 x 140 x 92 mm)
Weight	1.38 lb (630 g)
Operating temperature	0° to 35°C (32° to 95°F)
Operating humidity	90% maximum relative humidity, noncondensing

## Nighthawk Tri-band Mesh WiFi 6

Table 7. Technical specifications for the satellite (Continued)

Feature	Description
Electromagnetic emissions	FCC Part 15, Subpart B, Class B IECS-003, Class B EN 55032, EN 55035, Class B AS/NZS CISPR 32, Class B
LAN	RJ-45 port supporting 10BASE-T, 100BASE-TX, and 1000BASE-T
WiFi	Maximum wireless signal rate complies with the IEEE 802.11 standard. <sup>4</sup>
Radio data rates	2.4 GHz: Max 600 Mbps 5 GHz Front haul: Max 1200 Mbps 5 GHz Back haul: Max 1800 Mbps
Data encoding standards	IEEE 802.11b/g/n 2.4 GHz-1024 QAM support IEEE 802.11 a/n/ac 5 GHz-1024 QAM support
Maximum number of computers per wireless network	Limited by the amount of WiFi network traffic generated by each node (typically 50-70 nodes). 2.4 GHz: 127 5 GHz (front haul): 127
Operating frequency range	2.4 GHz: <ul style="list-style-type: none"> <li>• 2.412-2.462 GHz (US)</li> <li>• 2.412-2.472 GHz (Europe ETSI)</li> </ul> 5 GHz: <ul style="list-style-type: none"> <li>• 5.18 GHz-5.24 GHz and 5.745 GHz-5.825 GHz (US)</li> <li>• 5.18 GHz-5.24 GHz and 5.5 GHz-5.7 GHz (Europe)</li> <li>• 5.26 GHz-5.32 GHz (Europe)</li> </ul>
802.11 security	WPA-PSK [TKIP], WPA2-PSK [AES], WPA3-Personal

<sup>4</sup>Maximum wireless signal rate derived from IEEE Standard 802.11 specifications. Actual throughput can vary. Network conditions and environmental factors, including volume of network traffic, building materials and construction, and network overhead, lower actual data throughput rate.