

OPERATOR'S MANUAL

CRAFTSMAN[®]

5-1/2 in., 19.2 VOLT CORDLESS LASER TRIM SAW

Model No.
315.115160

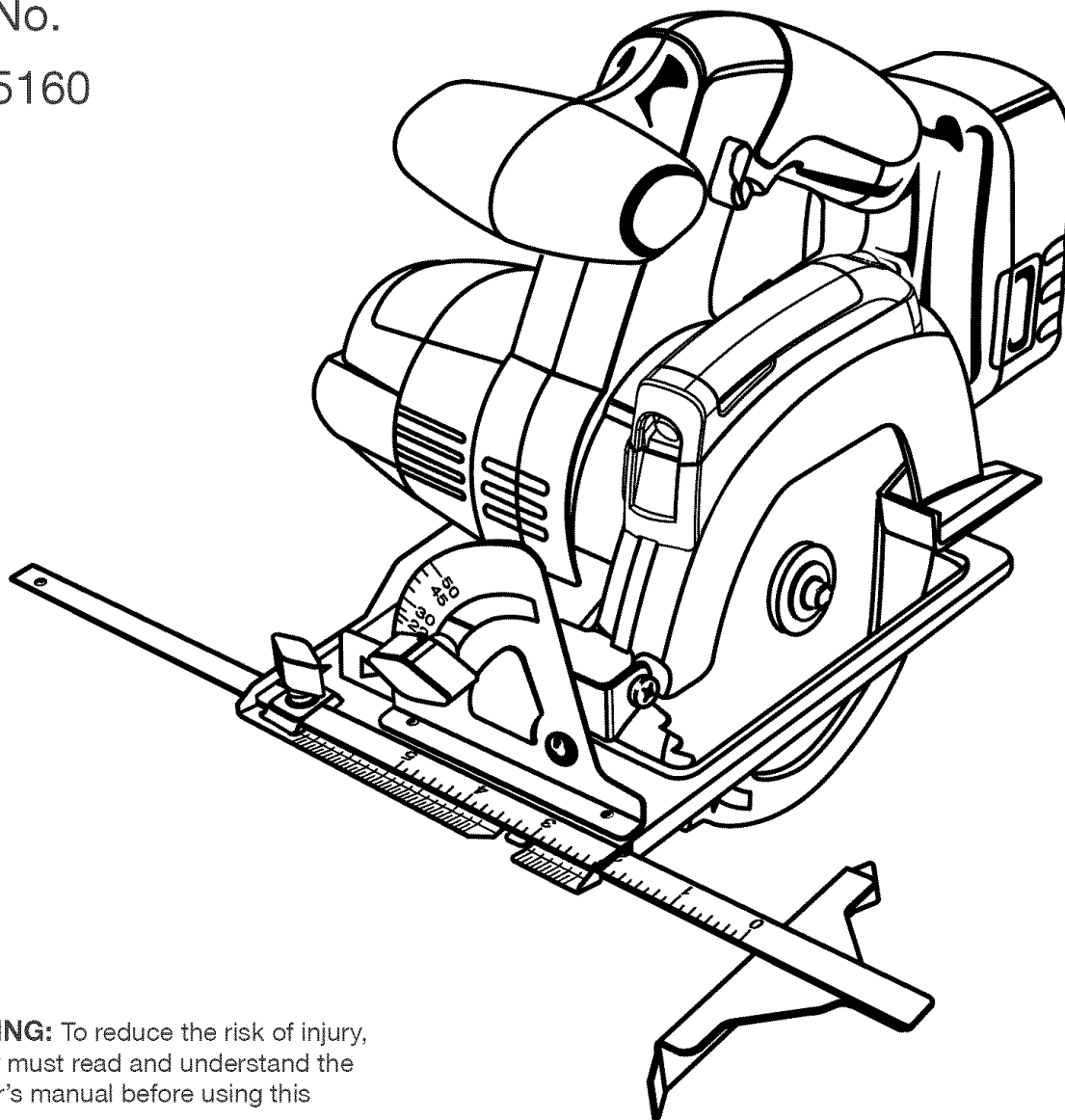

⚠ WARNING: To reduce the risk of injury, the user must read and understand the operator's manual before using this product.

Customer Help Line: 1-800-932-3188

Sears, Roebuck and Co., 3333 Beverly Rd., Hoffman Estates, IL 60179 USA
Visit the Craftsman web page: www.sears.com/craftsman

983000-490
9-04

Save this manual for future reference



TABLE OF CONTENTS

■ Warranty	2
■ Introduction	2
■ General Safety Rules	3-4
■ Specific Safety Rules	4-5
■ Safety Rules for Charger	6
■ Symbols	7-8
■ Features	9-10
■ Assembly	10-12
■ Operation	13-22
■ Adjustments	22
■ Maintenance	23-24
■ Accessories	24
■ Exploded View and Repair Parts List	25-26
■ Parts Ordering / Service	Back Page

WARRANTY

ONE YEAR FULL WARRANTY ON CRAFTSMAN TOOL

If this Craftsman tool fails to give complete satisfaction within one year from date of purchase, **RETURN IT TO THE NEAREST SEARS STORE OR SEARS PARTS & REPAIR CENTER IN THE UNITED STATES**, and Sears will repair it, free of charge.

If this Craftsman tool is used for commercial or rental purposes, this warranty applies for only 90 days from the date of purchase.

This warranty gives you specific legal rights, and you may also have other rights which vary from state to state.

Sears, Roebuck and Co., Dept. 817WA, Hoffman Estates, IL 60179

INTRODUCTION

This tool has many features for making its use more pleasant and enjoyable. Safety, performance, and dependability have been given top priority in the design of this product making it easy to maintain and operate.

GENERAL SAFETY RULES

▲ WARNING! READ AND UNDERSTAND ALL INSTRUCTIONS. Failure to follow all instructions listed below, may result in electric shock, fire and/or serious personal injury.

SAVE THESE INSTRUCTIONS

WORK AREA

- **Keep your work area clean and well lit.** Cluttered benches and dark areas invite accidents.
- **Do not operate power tools in explosive atmospheres, such as in the presence of flammable liquids, gases, or dust.** Power tools create sparks which may ignite the dust or fumes.
- **Keep bystanders, children, and visitors away while operating a power tool.** Distractions can cause you to lose control.

ELECTRICAL SAFETY

- **A battery operated tool with integral batteries or a separate battery pack must be recharged only with the specified charger for the battery.** A charger that may be suitable for one type of battery may create a risk of fire when used with another battery.
- **Use battery operated tool only with specifically designated battery pack.** Use of any other batteries may create a risk of fire.
- **Use battery only with charger listed.**

MODEL	BATTERY PACK	CHARGER
315.115160	Item No. <u>9</u> 11375 (1323517 or 1323903)	Item No. <u>9</u> 11041 (1425301)

- **Do not abuse the cord. Never use the cord to carry the charger. Keep cord away from heat, oil, sharp edges, or moving parts. Replace damaged cords immediately.** Damaged cords may create a fire.

PERSONAL SAFETY

- **Stay alert, watch what you are doing and use common sense when operating a power tool. Do not use tool while tired or under the influence of drugs, alcohol, or medication.** A moment of inattention while operating power tools may result in serious personal injury.
- **Dress properly. Do not wear loose clothing or jewelry. Contain long hair. Keep your hair, clothing, and gloves away from moving parts.** Loose clothes, jewelry, or long hair can be caught in moving parts.
- **Avoid accidental starting. Be sure switch is in the locked or off position before inserting battery pack.** Carrying tools with your finger on the switch or inserting the battery pack into a tool with the switch on invites accidents.
- **Remove adjusting keys or wrenches before turning the tool on.** A wrench or a key that is left attached to a rotating part of the tool may result in personal injury.

- **Do not overreach. Keep proper footing and balance at all times.** Proper footing and balance enable better control of the tool in unexpected situations.
- **Use safety equipment. Always wear eye protection.** Dust mask, non-skid safety shoes, hard hat, or hearing protection must be used for appropriate conditions.
- **Do not wear loose clothing or jewelry. Contain long hair.** Loose clothes, jewelry, or long hair can be drawn into air vents.
- **Do not use on a ladder or unstable support.** Stable footing on a solid surface enables better control of the tool in unexpected situations.

TOOL USE AND CARE

- **Use clamps or other practical way to secure and support the workpiece to a stable platform.** Holding the work by hand or against your body is unstable and may lead to loss of control.
- **Do not force tool. Use the correct tool for your application.** The correct tool will do the job better and safer at the rate for which it is designed.
- **Do not use tool if switch does not turn it on or off.** A tool that cannot be controlled with the switch is dangerous and must be repaired.
- **Disconnect battery pack from tool or place the switch in the locked or off position before making any adjustments, changing accessories, or storing the tool.** Such preventive safety measures reduce the risk of starting the tool accidentally.
- **Store idle tools out of reach of children and other untrained persons.** Tools are dangerous in the hands of untrained users.
- **When battery pack is not in use, keep it away from other metal objects like: paper clips, coins, keys, nails, screws, or other small metal objects that can make a connection from one terminal to another.** Shorting the battery terminals together may cause sparks, burns, or a fire.
- **Maintain tools with care. Keep cutting tools sharp and clean.** Properly maintained tools with sharp cutting edges are less likely to bind and are easier to control.
- **Check for misalignment or binding of moving parts, breakage of parts, and any other condition that may affect the tool's operation. If damaged, have the tool serviced before using.** Many accidents are caused by poorly maintained tools.
- **Use only accessories that are recommended by the manufacturer for your model.** Accessories that may be suitable for one tool may create a risk of injury when used on another tool.
- **Keep the tool and its handle dry, clean and free from oil and grease.** Always use a clean cloth when cleaning. Never use brake fluids, gasoline, petroleum-based products, or any strong solvents to clean your tool. Following this rule will reduce the risk of loss of control and deterioration of the enclosure plastic.

GENERAL SAFETY RULES

SERVICE

- **Tool service must be performed only by qualified repair personnel.** Service or maintenance performed by unqualified personnel may result in a risk of injury.
- **When servicing a tool, use only identical replacement parts. Follow instructions in the Maintenance section of this manual.** Use of unauthorized parts or failure to follow Maintenance Instructions may create a risk of shock or injury.

SPECIFIC SAFETY RULES

- **DANGER! Keep hands away from cutting area and blade. Keep your second hand on auxiliary handle or motor housing.** If both hands are holding the saw, they cannot be cut by the blade.
 - **Keep your body positioned to either side of the saw blade, but not in line with the saw blade.** KICKBACK could cause the saw to jump backwards. (see KICKBACK)
 - **Do not reach underneath the work.** The guard cannot protect you from the blade below the work.
 - **Check the lower guard for proper closing before each use. Do not operate saw if lower guard does not move freely and close instantly. Never clamp or tie the lower guard into the open position.** If saw is accidentally dropped, lower guard may be bent. Raise the lower guard with the retracting handle and make sure it moves freely and does not touch the blade or any other part, in all angles and depths of cut.
 - **Check the operation and condition of the lower guard spring. If the guard and the spring are not operating properly, they must be serviced before use.** Lower guard may operate sluggishly due to damaged parts, gummy deposits, or a buildup of debris.
 - **Lower guard should be retracted manually only for special cuts such as “Pocket Cuts” and “Compound Cuts”.** Raise lower guard by Retracting Handle. As soon as blade enters the material, lower guard must be released. For all other sawing, the lower guard should operate automatically.
 - **Always observe that the lower guard is covering the blade before placing saw down on bench or floor.** An unprotected, coasting blade will cause the saw to walk backwards, cutting whatever is in its path. Be aware of the time it takes for the blade to stop after switch is released.
 - **NEVER hold piece being cut in your hands or across your leg.** It is important to support the work properly to minimize body exposure, blade binding, or loss of control.
 - **Hold tool by insulated gripping surfaces when performing an operation where the cutting tool may contact hidden wiring.** Contact with a “live” wire will also make exposed metal parts of the tool “live” and shock the operator.
 - **When ripping always use a rip fence or straight edge guide.** This improves the accuracy of cut and reduces the chance of blade binding.
 - **Always use blades with correct size and shape (diamond vs. round) arbor holes.** Blades that do not match the mounting hardware of the saw will run eccentrically, causing loss of control.
 - **Never use damaged or incorrect blade washers or bolts.** The blade washers and bolt were specially designed for your saw, for optimum performance and safety of operation.
- Causes and Operator Prevention of Kickback:**
- Kickback is a sudden reaction to a pinched, bound, or misaligned saw blade, causing an uncontrolled saw to lift up and out of the workpiece toward the operator.*
- When the blade is pinched or bound tightly by the kerf closing down, the blade stalls and the motor reaction drives the unit rapidly back toward the operator.*
- If the blade becomes twisted or misaligned in the cut, the teeth at the back edge of the blade can dig into the top surface of the wood causing the blade to climb out of the kerf and jump back toward the operator.*
- Kickback is a result of tool misuse and/or incorrect operating procedures or conditions and can be avoided by taking proper precautions as given below:*
- **Maintain a firm grip on the saw and position your body and arm in a way that allows you to resist KICKBACK forces.** KICKBACK forces can be controlled by the operator, if proper precautions are taken.
 - **When blade is binding, or when interrupting a cut for any reason, release the trigger and hold the saw motionless in the material until the blade comes to a complete stop. Never attempt to remove the saw from the work or pull the saw backward while the blade is in motion or KICKBACK may occur.** Investigate and take corrective actions to eliminate the cause of blade binding.
 - **When restarting a saw in the workpiece, center the saw blade in the kerf and check that teeth are not engaged into the material.** If saw blade is binding, it may walk up or KICKBACK from the workpiece as the saw is restarted.
 - **Support large panels to minimize the risk of blade pinching and KICKBACK.** Large panels tend to sag under their own weight. Supports must be placed under the panel on both sides, near the line of cut and near the edge of the panel.

SPECIFIC SAFETY RULES

- **Do not use dull or damaged blade.** Unsharpened or improperly set blades produce narrow kerf causing excessive friction, blade binding, and KICKBACK.
- **Blade depth and bevel adjusting locking levers must be tight and secure before making cut.** If blade adjustment shifts while cutting, it will cause binding and KICKBACK.
- **Use extra caution when making a “Pocket Cut” into existing walls or other blind areas.** The protruding blade may cut objects that can cause KICKBACK.
- **Know your power tool. Read operator’s manual carefully. Learn its applications and limitations, as well as the specific potential hazards related to this tool.** Following this rule will reduce the risk of electric shock, fire, or serious injury.
- **Always wear safety glasses with side shields.** Everyday glasses have only impact resistant lenses. They are NOT safety glasses. Following this rule will reduce the risk of eye injury.
- **Battery tools do not have to be plugged into an electrical outlet; therefore, they are always in operating condition. Be aware of possible hazards when not using your battery tool or when changing accessories.** Following this rule will reduce the risk of electric shock, fire, or serious personal injury.
- **Do not place battery tools or their batteries near fire or heat.** This will reduce the risk of explosion and possibly injury.
- **Never use a battery that has been dropped or received a sharp blow.** A damaged battery is subject to explosion. Properly dispose of a dropped or damaged battery immediately.
- **Batteries vent hydrogen gas and can explode in the presence of a source of ignition, such as a pilot light.** To reduce the risk of serious personal injury, never use any cordless product in the presence of open flame. An exploded battery can propel debris and chemicals. If exposed, flush with water immediately.
- **Do not charge battery tool in a damp or wet location.** Following this rule will reduce the risk of electric shock.
- **For best results, your battery tool should be charged in a location where the temperature is more than 50°F but less than 100°F. Do not store outside or in vehicles.**
- **Under extreme usage or temperature conditions, battery leakage may occur. If liquid comes in contact with your skin, wash immediately with soap and water, then neutralize with lemon juice or vinegar. If liquid gets into your eyes, flush them with clean water for at least 10 minutes, then seek immediate medical attention.** Following this rule will reduce the risk of serious personal injury.

Laser Guide Warnings:

The laser guide radiation used in the Craftsman trim saw is Class II with maximum <1 mW and 650nm wavelengths. These lasers do not normally present an optical hazard although staring at the beam may cause flash blindness.

- **Avoid** direct eye exposure when using the laser guide.
- The laser shall be used and maintained in accordance with the manufacturer’s instructions.
- Never aim the beam at a person or object other than the workpiece.
- Always ensure the laser beam is aimed at a sturdy workpiece without reflective surfaces. Shiny reflective sheet metal or similar shiny materials are not suitable for laser use.
- All repairs should be made by an authorized service representative or the laser manufacturer.

SAFETY RULES FOR CHARGER

 **WARNING! READ AND UNDERSTAND ALL INSTRUCTIONS.** Failure to follow all instructions listed below, may result in electric shock, fire and/or serious personal injury.

■ **Before using battery charger,** read all instructions and cautionary markings in this manual, on battery charger, battery, and product using battery to prevent misuse of the products and possible injury or damage.

 **CAUTION:** To reduce the risk of electric shock or damage to the charger and battery, charge only nickel-cadmium rechargeable batteries as specifically designated on your charger. Other types of batteries may burst, causing personal injury or damage.

■ **Do not use charger outdoors or expose to wet or damp conditions.** Water entering charger will increase the risk of electric shock.

■ **Use of an attachment not recommended or sold by the battery charger manufacturer may result in a risk of fire, electric shock, or injury to persons.** Following this rule will reduce the risk of electric shock, fire, or serious personal injury.

■ **Do not abuse cord or charger.** Never use the cord to carry the charger. Do not pull the charger cord rather than the plug when disconnecting from receptacle. Damage to the cord or charger could occur and create an electric shock hazard. Replace damaged cords immediately.

■ **Make sure cord is located so that it will not be stepped on, tripped over, come in contact with sharp edges or moving parts or otherwise subjected to damage or stress.** This will reduce the risk of accidental falls, which could cause injury, and damage to the cord, which could result in electric shock.

■ **Keep cord and charger from heat to prevent damage to housing or internal parts.**

■ **Do not let gasoline, oils, petroleum-based products, etc. come in contact with plastic parts.** They contain chemicals that can damage, weaken, or destroy plastic.

■ **An extension cord should not be used unless absolutely necessary.** Use of improper extension cord could result in a risk of fire and electric shock. If extension cord must be used, make sure:

- That pins on plug of extension cord are the same number, size and shape as those of plug on charger.
- That extension cord is properly wired and in good electrical condition; and
- That wire size is large enough for AC ampere rating of charger as specified below:

Cord Length (Feet)	25'	50'	100'
Cord Size (AWG)	16	16	16

NOTE: AWG = American Wire Gauge

- **Do not operate charger with a damaged cord or plug,** which could cause shorting and electric shock. If damaged, have the charger replaced by an authorized serviceman.
- **Do not operate charger if it has received a sharp blow, been dropped, or otherwise damaged in any way.** Take it to an authorized serviceman for electrical check to determine if the charger is in good working order.
- **Do not disassemble charger.** Take it to an authorized serviceman when service or repair is required. Incorrect reassembly may result in a risk of electric shock or fire.
- **Unplug charger from outlet before attempting any maintenance or cleaning to reduce the risk of electric shock.**
- **Disconnect charger from the power supply when not in use.** This will reduce the risk of electric shock or damage to the charger if metal items should fall into the opening. It also will help prevent damage to the charger during a power surge.
- **Risk of electric shock.** Do not touch uninsulated portion of output connector or uninsulated battery terminal.
- **Save these instructions.** Refer to them frequently and use them to instruct others who may use this tool. If you loan someone this tool, loan them these instructions also to prevent misuse of the product and possible injury.











 **WARNING:** Some dust created by power sanding, sawing, grinding, drilling, and other construction activities contains chemicals known to cause cancer, birth defects or other reproductive harm. Some examples of these chemicals are:

- lead from lead-based paints,
- crystalline silica from bricks and cement and other masonry products, and
- arsenic and chromium from chemically-treated lumber.

Your risk from these exposures varies, depending on how often you do this type of work. To reduce your exposure to these chemicals: work in a well ventilated area, and work with approved safety equipment, such as those dust masks that are specially designed to filter out microscopic particles.



SYMBOLS

Some of the following symbols may be used on this tool. Please study them and learn their meaning. Proper interpretation of these symbols will allow you to operate the tool better and safer.

SYMBOL	NAME	DESIGNATION/EXPLANATION
V	Volts	Voltage
A	Amperes	Current
Hz	Hertz	Frequency (cycles per second)
W	Watt	Power
min	Minutes	Time
~	Alternating Current	Type of current
≡	Direct Current	Type or a characteristic of current
n_0	No Load Speed	Rotational speed, at no load
	Class II Construction	Double-insulated construction
.../min	Per Minute	Revolutions, strokes, surface speed, orbits etc., per minute
	Wet Conditions Alert	Do not expose to rain or use in damp locations.
	Read The Operator's Manual	To reduce the risk of injury, user must read and understand operator's manual before using this product.
	Eye Protection	Always wear safety goggles or safety glasses with side shields and a full face shield when operating this product.
	Safety Alert	Precautions that involve your safety.
	No Hands Symbol	Failure to keep your hands away from the blade will result in serious personal injury.
	No Hands Symbol	Failure to keep your hands away from the blade will result in serious personal injury.
	No Hands Symbol	Failure to keep your hands away from the blade will result in serious personal injury.
	No Hands Symbol	Failure to keep your hands away from the blade will result in serious personal injury.
	Hot Surface	To reduce the risk of injury or damage, avoid contact with any hot surface.

SYMBOLS

The following signal words and meanings are intended to explain the levels of risk associated with this product.

SYMBOL	SIGNAL	MEANING
	DANGER:	Indicates an imminently hazardous situation, which, if not avoided, will result in death or serious injury.
	WARNING:	Indicates a potentially hazardous situation, which, if not avoided, could result in death or serious injury.
	CAUTION:	Indicates a potentially hazardous situation, which, if not avoided, may result in minor or moderate injury.
	CAUTION:	(Without Safety Alert Symbol) Indicates a situation that may result in property damage.

SERVICE

Servicing requires extreme care and knowledge and should be performed only by a qualified service technician. For service we suggest you return the product to your nearest **AUTHORIZED SERVICE CENTER** for repair. When servicing, use only identical replacement parts.

 **WARNING:** To avoid serious personal injury, do not attempt to use this product until you read thoroughly and understand completely the operator's manual. Save this operator's manual and review frequently for continuing safe operation and instructing others who may use this product.

WARNING:



The operation of any power tool can result in foreign objects being thrown into your eyes, which can result in severe eye damage. Before beginning power tool operation, always wear safety goggles or safety glasses with side shields and a full face shield when needed. We recommend Wide Vision Safety Mask for use over eyeglasses or standard safety glasses with side shields. Always use eye protection which is marked to comply with ANSI Z87.1.

SAVE THESE INSTRUCTIONS

FEATURES

PRODUCT SPECIFICATIONS

Motor	19.2 Volt DC
Blade diameter	5-1/2 in. (140 mm)
Blade Arbor	3/8 in. (9.53 mm)
Cutting Depth at 0°	1-9/16 in. (39.69 mm)
Cutting Depth at 45°	1-1/8 in. (28.58 mm)
No Load Speed	4500/min.
Charger Input	120 V, 60 Hz, AC only
Charge Rate	1 Hr.
Laser Guide	Class II, <1 mW max, 650nm

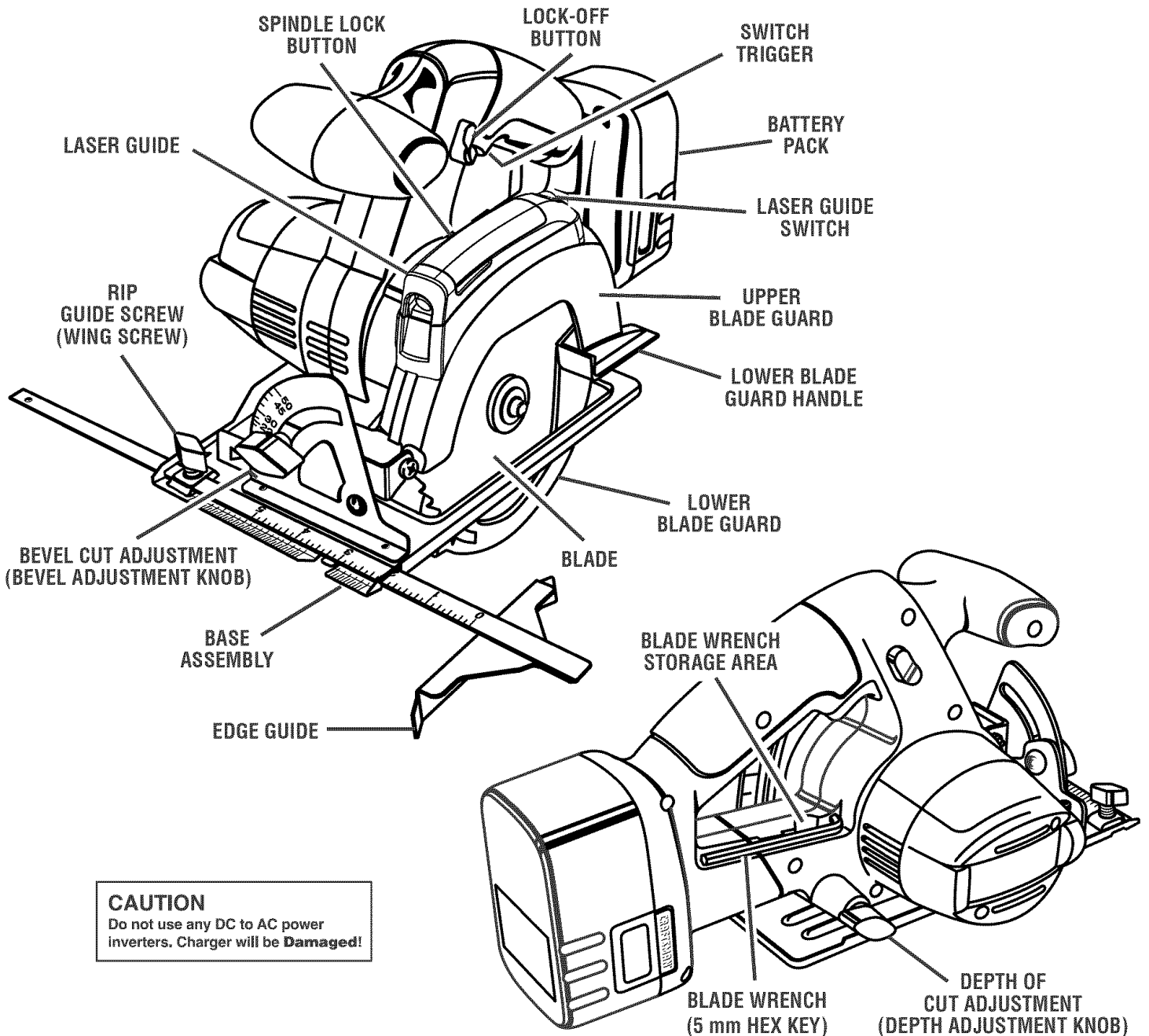

Fig.1

FEATURES

KNOW YOUR LASER TRIM SAW

See Figure 1.

Before attempting to use this product, familiarize yourself with all operating Features and Safety Rules

EDGE GUIDE

Edge guide is used when making long or wide rip cuts with the saw.

SWITCH TRIGGER

The trim saw is equipped with a pre-travel safety switch which reduces the possibility of accidental starting. When you depress the switch, the saw will not start until you reach the pre-travel position. You must depress the switch fully to activate the saw.

BLADE WRENCH STORAGE

Convenient wrench storage for quick blade changes.

DEPTH CUT

Adjusts the depth of cut from 0 in. to 1-9/16 in.

SPINDLE LOCK

The spindle lock allows you to secure the blade when turning the blade screw.

NOTE: Do not run trim saw with spindle lock engaged.

DUST CHUTE

To direct saw dust and chips away from the operator, a dust chute is located on the side of the upper blade guard.

ERGONOMIC DESIGN

The design of your trim saw provides for maintaining proper two hand control when cutting. It has been designed to be comfortable and easy to grasp.

LASER GUIDE

The laser guide will generate a red colored line on the work surface when turned on.

ASSEMBLY

UNPACKING

This product requires assembly.

- Carefully remove the tool and accessories from the box. Make sure that all items listed in the packing list are included.
- Inspect the tool carefully to make sure no breakage or damage occurred during shipping.
- Do not discard the packing material until you have carefully inspected and satisfactorily operated the tool.
- If any parts are damaged or missing, please call 1-800-932-3188 for assistance.

PACKING LIST

Cordless Trim Saw with Laser
5-1/2 in. (140 mm) Blade
Battery Pack
Laser Batteries
Charger
Edge Guide
Blade Wrench
Operator's Manual

WARNING: If any parts are missing do not operate the tool until the missing parts are replaced. Failure to do so could result in possible serious personal injury.

WARNING: Do not attempt to modify this tool or create accessories not recommended for use with this tool. Any such alteration or modification is misuse and could result in a hazardous condition leading to possible serious personal injury.

WARNING: To prevent accidental starting that could cause serious personal injury, always remove the battery pack from the tool when assembling parts.

REMOVING BATTERY PACK

See Figure 2.

- Locate latches on side of battery pack and depress to release battery pack from your saw.
- Remove battery pack from your saw.

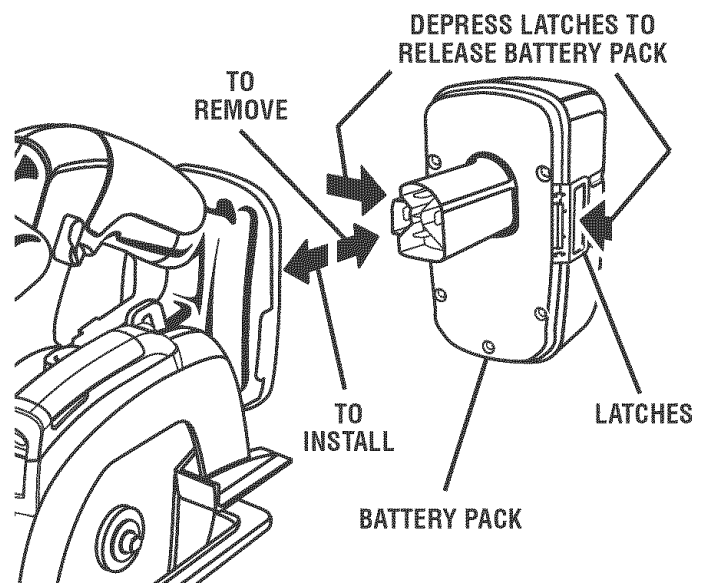

Fig. 2

ASSEMBLY

INSTALLING BATTERY PACK

See Figure 3.

NOTE: Battery pack is shipped in a low charge condition. Therefore, it must be charged prior to use. Refer to page 13, “**CHARGING BATTERY PACK**” for charging instructions.

- Place battery pack in your saw. Align raised rib on battery pack with groove inside saw, then slide battery pack in saw as shown in figure 5.
- Make sure the latches on each side of your battery pack snap into place and battery pack is secured in saw before beginning operation.

CAUTION: When placing battery pack in your saw, be sure raised rib on battery pack aligns with groove inside saw and latches snap into place properly. Improper assembly can cause damage to saw and battery pack.

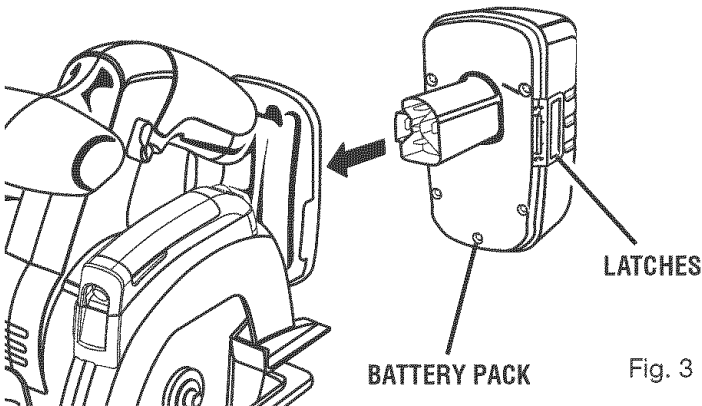

ATTACHING BLADE

See Figure 4.

WARNING: A 5-1/2 in. (140 mm) blade is the maximum blade capacity of your saw. Never use a blade that is too thick to allow outer blade washer to engage with the flats on the spindle. Larger blades will come in contact with the blade guard, while thicker blades will prevent blade screw from securing blade on spindle. Either of these situations could result in a serious accident.

- Remove battery pack from saw.
- Locate latches on side of battery pack and depress to release battery pack from your saw.
- Remove blade wrench (5 mm hex key) from storage area.

- Depress spindle lock button and remove blade screw and outer blade washer.

NOTE: Turn blade screw clockwise to remove.

- Wipe a drop of oil onto inner blade washer and outer blade washer where they contact blade.

WARNING: If inner blade washer has been removed, replace it before placing blade on spindle. Failure to do so could cause an accident since blade will not tighten properly.

- Fit saw blade inside lower blade guard and onto spindle.

NOTE: The saw teeth point upward at the front of saw as shown in figure 3.

- Replace outer blade washer.

- Depress spindle lock button, then replace blade screw. Tighten blade screw securely.

NOTE: Turn blade screw counterclockwise to tighten.

- Return blade wrench to storage area.

NOTE: Never use a blade that is too thick to allow the outer blade washer to engage with the flats on the spindle.

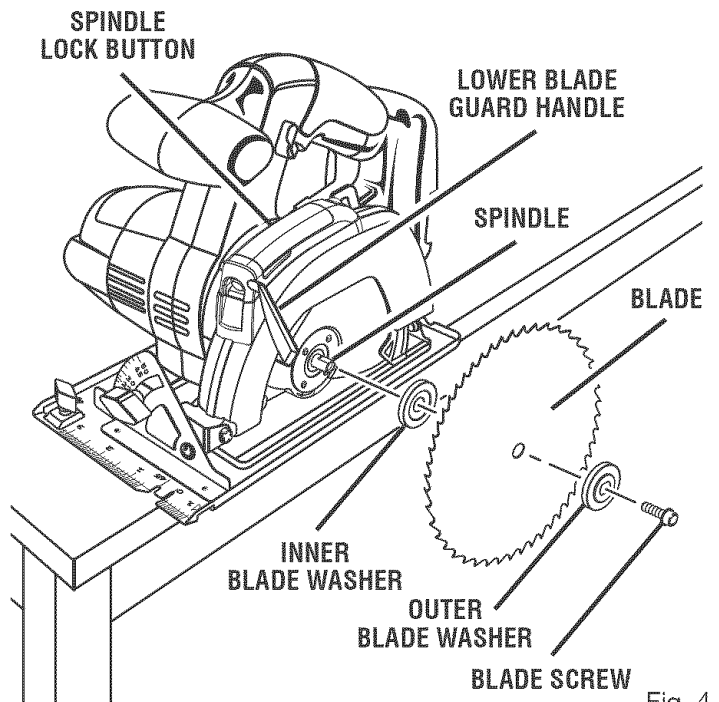

ASSEMBLY

REMOVING BLADE

See Figure 5.

- Remove battery pack from saw.
- Remove blade wrench from storage area.
- Position saw as shown in figure 5, depress spindle lock button, and remove blade screw.

NOTE: Turn blade screw clockwise to remove.

- Remove outer blade washer.

NOTE: Blade can be removed at this point.

- ▲ **WARNING:** Current attachments and accessories available for use with this tool are listed above. Do not use any attachments or accessories not recommended by the manufacturer of this tool. The use of attachments or accessories not recommended can result in serious personal injury.

EDGE GUIDE

Use the edge guide provided with your saw when making wide rip cuts. A five inch scale has been provided on the edge guide. When using the width of cut scale on the base in combination with the edge guide, cuts can be made up to 6 in. to the left of the edge guide or 8-7/8 in. to the right of the edge guide.

The edge guide helps prevent the blade from twisting in a cut. The blade twisting in a cut can cause kickback.

INSTALLING EDGE GUIDE

See Figure 6.

- Remove battery pack from saw.
- Place edge guide through holes in saw base.
- Adjust edge guide to the width needed.
- Tighten edge guide screw (wing screw) securely.

NOTE: When using a edge guide, position the face of the edge guide firmly against the edge of workpiece. This makes for a true cut without pinching the blade. The guiding edge of workpiece must be straight for your cut to be straight. Use caution to prevent the blade from binding in the cut.

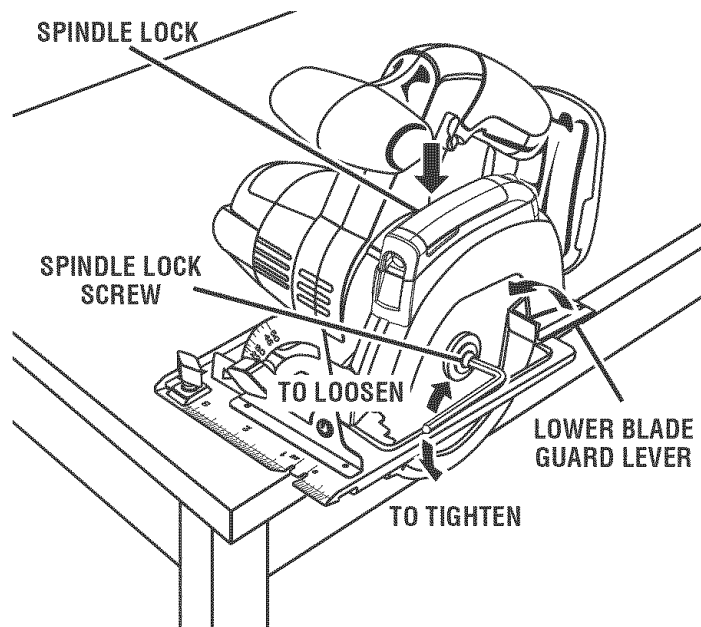

Fig. 5

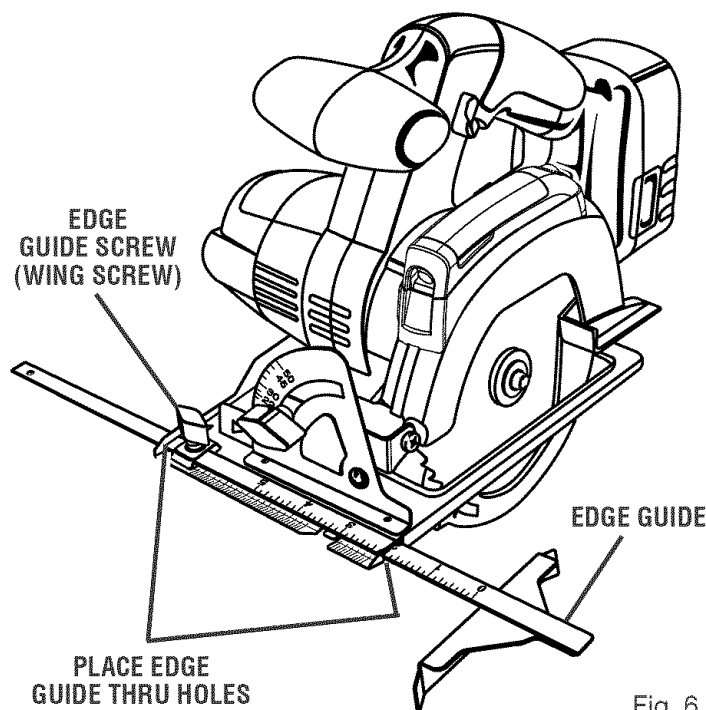

Fig. 6

OPERATION

WARNING: Do not allow familiarity with tools to make you careless. Remember that a careless fraction of a second is sufficient to inflict serious injury.

WARNING: Always wear safety goggles or safety glasses with side shields when operating tools. Failure to do so could result in objects being thrown into your eyes, resulting in possible serious injury.

APPLICATIONS

You may use this tool for the following purposes:

- Cutting all types of wood products (lumber, plywood, paneling).
- Cross Cutting/Rip Cutting
- Bevel Cutting
- Pocket Cutting

CAUTION: To prevent damage to the battery pack, remove the battery pack from the charger immediately if no LED comes on. Return the battery pack and charger to your nearest service center for checking or replacing. Also, if you are removing the battery pack from the charger and no LEDs are on, return both the battery pack and the charger to your nearest service center. Do not insert another battery pack into the charger. A damaged charger may damage a battery pack.

LED FUNCTIONS OF CHARGER

LED WILL BE ON TO INDICATE STATUS OF CHARGER AND BATTERY PACK:

- Red LED on = Fast charging mode.
- Green LED on = Fully charged and in trickle charge mode.
- Green LED on = When battery pack is inserted into charger, indicates hot battery pack or that battery pack is out of or below normal temperature range.
- Yellow and Green LEDs on = Deeply discharged or defective battery pack.
- No LED on = Defective charger or battery pack.

CHARGING THE BATTERY PACK

The battery pack for this tool has been shipped in a low charge condition to prevent possible problems. Therefore, you should charge it until the green LED on the front of the charger comes on.

NOTE: Batteries will not reach full charge the first time they are charged. Allow several cycles (operation followed by recharging) for them to become fully charged.

CHARGING A COOL BATTERY PACK

If battery pack is below normal temperature range, the green LED on charger will come on. Allow battery pack to reach normal temperature, then the red LED will come on.

NOTE: If the charger does not charge the battery pack under normal circumstances, return both the battery pack and charger to your nearest Sears Repair Center for electrical check.

- Charge the battery pack only with the charger provided.
 - Make sure the power supply is normal household voltage, **120 volts, 60 Hz, AC only**.
 - Connect the charger to the power supply.
 - Place the battery pack in the charger aligning raised rib on the battery pack with the groove in the charger. *See Figure 7.*
 - Press down on the battery pack to be sure contacts on the battery pack engage properly with contacts in the charger.
 - Normally the red LED on charger will come on. This indicates the charger is in fast charging mode.
 - Red LED should remain on for approximately 1 hour then the green LED will come on. Green LED on indicates battery pack is fully charged and charger is in maintenance charge mode.
- NOTE:** The green LED will remain on until the battery pack is removed from the charger or charger is disconnected from the power supply.
- If both yellow and green LEDs come on, this indicates a deeply discharged or defective battery pack. Allow the battery pack to remain in the charger for 15 to 30 minutes. When the battery pack reaches normal voltage range, the red LED should come on. If the red LED does not come on after 30 minutes, this may indicate a defective battery pack and should be replaced.
 - After normal usage, a minimum of 1 hour of charging time is required to fully recharge battery pack.
 - The battery pack will become slightly warm to the touch while charging. This is normal and does not indicate a problem.
 - Do not place the charger and battery pack in an area of extreme heat or cold. They will work best at normal room temperature.

NOTE: The charger and battery pack should be placed in a location where the temperature is more than 50°F but less than 100°F.

- When batteries become fully charged, unplug the charger from power supply and remove the battery pack.

CAUTION

Do not use any DC to AC power inverters. Charger will be **Damaged!**

OPERATION

CHARGING A HOT BATTERY PACK

When using the tool continuously, the batteries in the battery pack will become hot. You should let a hot battery pack cool down for approximately 30 minutes before attempting to recharge. When the battery pack becomes discharged and is hot, this will cause the green LED to come on instead of the red LED. After 30 minutes, reinsert the battery pack in the charger. If the green LED continues to remain on, return battery pack to your nearest Sears Repair Center for checking or replacing.

NOTE: This situation only occurs when continuous use of the tool causes the batteries to become hot. It does not occur under normal circumstances. Refer to **“CHARGING A COOL BATTERY PACK”** for normal recharging of batteries. If the charger does not charge your battery pack under normal circumstances, return both the battery pack and charger to your nearest Sears Repair Center for electrical check.

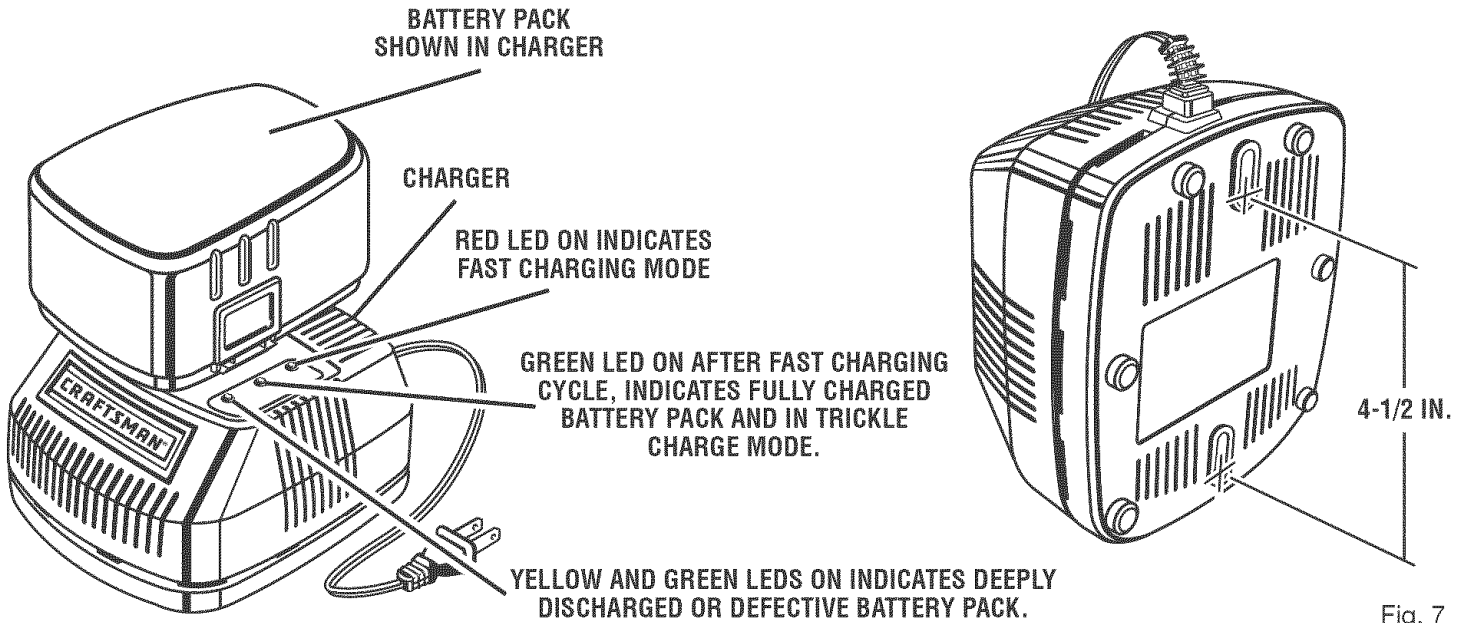

Fig. 7

OPERATION

KICKBACK

See Figures 8 - 11.

Kickback occurs when the blade stalls rapidly and the saw is driven back towards you. Blade stalling is caused by any action which pinches the blade in the wood.

⚠ DANGER: Release switch immediately if blade binds or saw stalls. Kickback could cause you to lose control of the saw. Loss of control can lead to serious injury.

To guard against kickback, avoid dangerous practices such as the following.

- Setting blade depth incorrectly.
- Sawing into knots or nails in workpiece.
- Twisting the blade while making a cut.
- Making a cut with a dull, gummed up, or improperly set blade.
- Supporting the workpiece incorrectly.
- Forcing a cut.
- Cutting warped or wet lumber.
- Operating the tool incorrectly or misusing the tool.

To lessen the chance of kickback, follow these safety practices.

- Keep the blade at the correct depth setting. The depth setting should not exceed 1/4 in. (6.35 mm) below the material being cut.
- Inspect the workpiece for knots or nails before cutting. Never saw into a knot or nail.
- Make straight cuts. Always use a straight edge guide when rip cutting. This helps prevent twisting the blade.
- Use clean, sharp, and properly set blades. Never make cuts with dull blades.
- Support the workpiece properly before beginning a cut.
- Use steady, even pressure when making a cut. Never force a cut.
- Do not cut warped or wet lumber.
- Hold the saw firmly with both hands and keep your body in a balanced position so as to resist the forces if kickback should occur.

⚠ WARNING: When using the saw, always stay alert and exercise control. Do not remove the saw from the workpiece while the blade is moving.

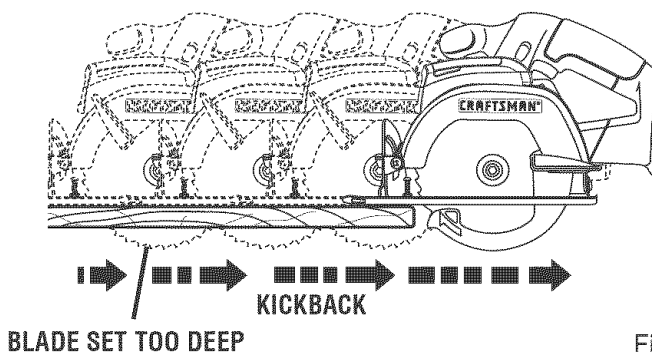

Fig. 8

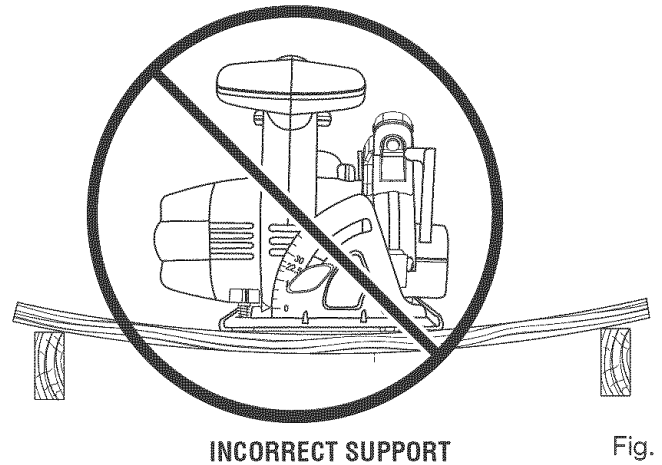

Fig. 9

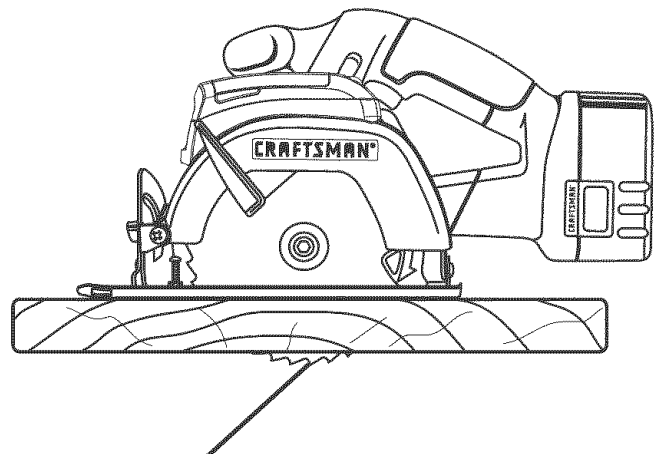

Fig. 10

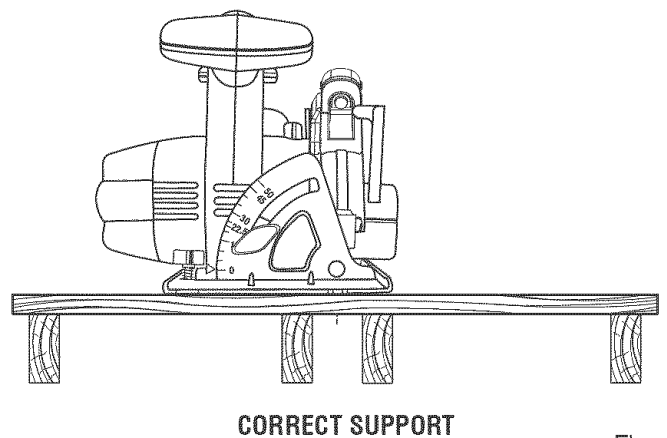

Fig. 11

OPERATION

SAW BLADES

The best of saw blades will not cut efficiently if they are not kept clean, sharp, and properly set. Using a dull blade will place a heavy load on the saw and increase the danger of kickback. Keep extra blades on hand, so that sharp blades are always available.

Gum and wood pitch hardened on blades will slow the saw down. Remove saw blade from the saw and use gum and pitch remover, hot water, or kerosene to remove these accumulations. **DO NOT USE GASOLINE.**

BLADE GUARD SYSTEM

See Figure 12.

The lower blade guard attached to your trim saw is there for your protection and safety. Do not alter it for any reason. If it becomes damaged, do not operate the saw until you have the guard repaired or replaced. Always leave guard in operating position when using the saw.

▲ DANGER: When sawing through work, lower blade guard does not cover blade on the underside of work. Since blade is exposed on underside of work, keep hands and fingers away from cutting area. Any part of your body coming in contact with moving blade will result in serious injury.

▲ CAUTION: Never use saw when guard is not operating correctly. Check the guard for correct operation before each use. The guard is operating correctly when it moves freely and readily returns to the closed position. If you drop the saw, check the lower blade guard and bumper for damage at all depth settings before reuse.

LOWER BLADE GUARD IS IN UP POSITION WHEN MAKING A CUT

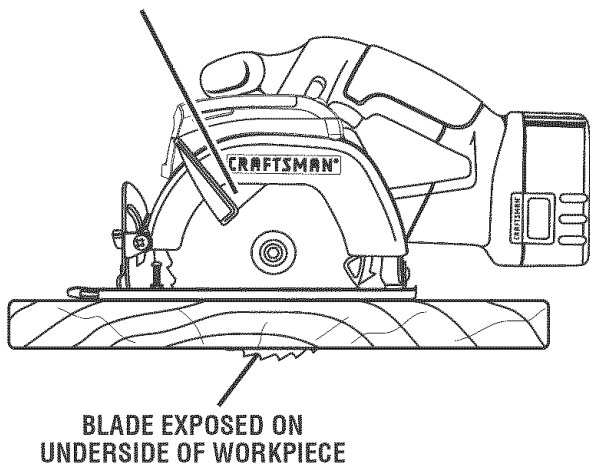

Fig. 12

STARTING/STOPPING THE SAW

See Figure 13.

To start the saw: Depress the switch trigger.

Always let the blade reach full speed, then guide the saw into the workpiece.

▲ WARNING: The blade coming in contact with the workpiece before it reaches full speed could cause the saw to “kickback” towards you resulting in serious injury.

To stop the saw: Release the switch trigger.

After you release the switch trigger, allow the blade to come to a complete stop. **Do not remove the saw from the workpiece while the blade is moving.**

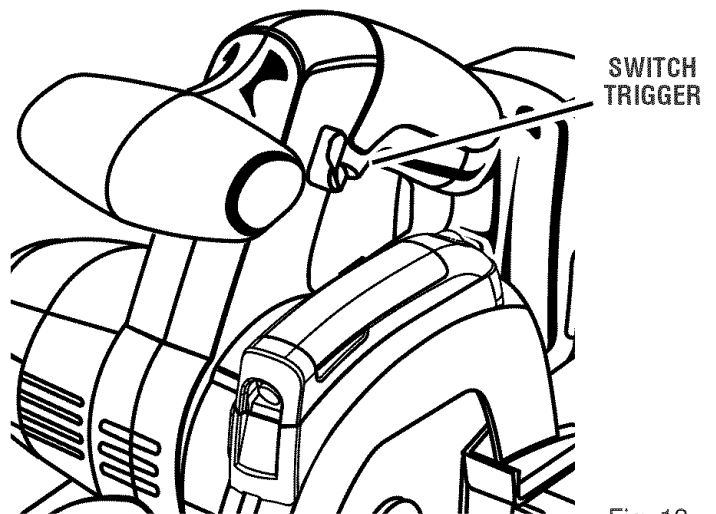

Fig. 13

OPERATION

ADJUSTING BLADE DEPTH

See Figure 14.

Always keep correct blade depth setting. The correct blade depth setting for all cuts should not exceed 1/4 in. (6.35 mm) below the material being cut. More blade depth will increase the chance of kickback and cause the cut to be rough. For more depth of cut accuracy, a scale is located on the upper blade guard.

Follow these directions to adjust the blade depth.

- Remove battery pack from saw.

⚠ WARNING: Failure to remove battery pack from the tool could result in accidental starting causing serious injury.

- Loosen depth adjustment knob.
- Determine the desired depth of cut.
- Locate depth of cut scale on back of upper blade guard.
- Hold base flat against the workpiece and raise or lower saw until the indicator mark on bracket aligns with notch on blade guard.
- Tighten depth adjustment knob securely.

USING THE LASER GUIDE

See Figure 15

⚠ WARNING: Do not stare into the laser beam or turn the laser on when the tool is not in use. Failure to do so could result in possible serious personal injury. The laser unit comes from the factory already installed and aligned. If the laser becomes misaligned after time refer to the "adjustments" section.

NOTE: Make a trial cut on a piece of scrap to ensure laser is aligned, adjusting the laser may be necessary.

- Mark the line to be cut on the workpiece.
- Adjust the depth and angle of the cut as needed.
- Switch on the laser beam.
- Install battery pack into the tool and start the motor.

NOTE: Do not touch the blade to the workpiece until the saw has reached maximum speed.

- Slowly push the saw forward into the workpiece.

NOTE: Keep the laser beam on the marked line on the workpiece for precision cutting.

- Once the cut is complete, allow the saw to come to a complete stop before turning off the laser.
- Remove battery pack from saw.

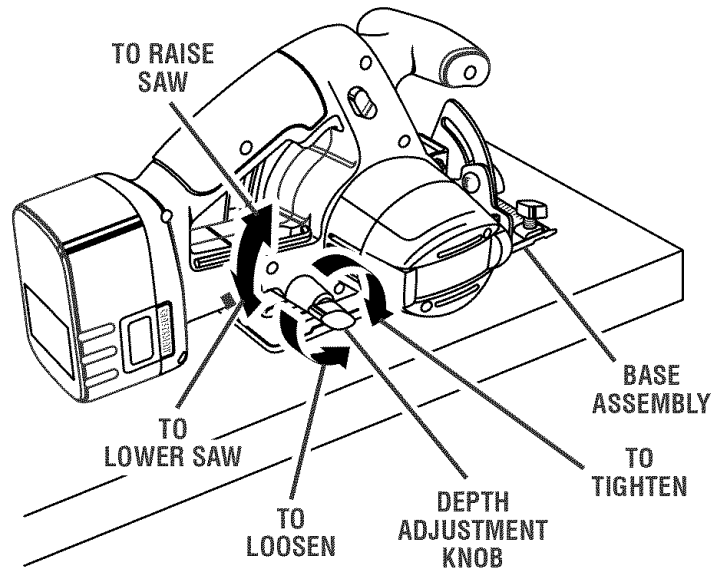

Fig. 14

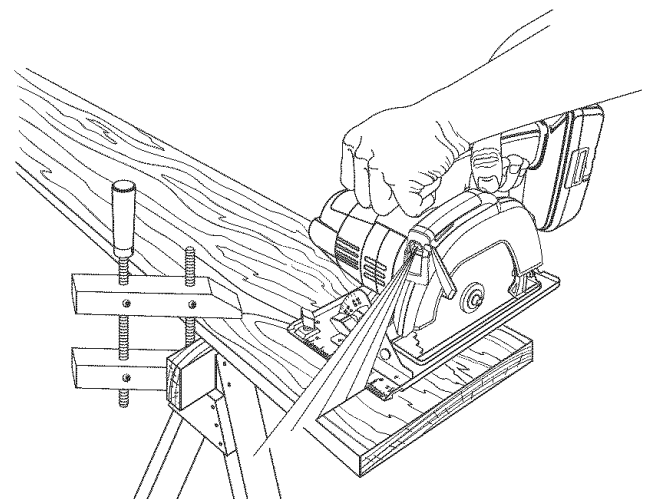
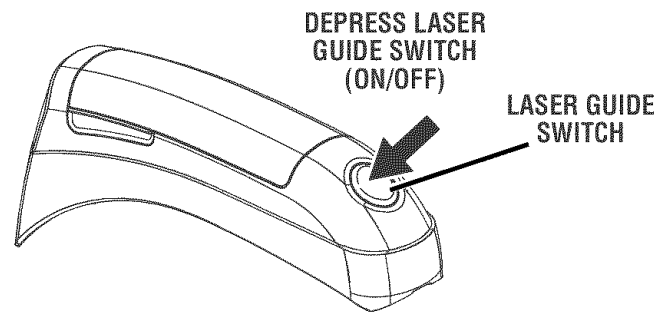

Fig. 15

OPERATION

OPERATING THE SAW

See Figures 16 - 18.

It is important to understand the correct method for operating the saw. Refer to the figures in this section to learn the correct and incorrect ways for handling the saw.

⚠ WARNING: To make sawing easier and safer, always maintain proper control of the saw. Loss of control could cause an accident resulting in possible serious injury.

⚠ DANGER: When lifting the saw from the workpiece, the blade is exposed on the underside of the saw until the lower blade guard closes. Make sure the lower blade guard is closed before setting the saw down.

To make the best possible cut, follow these helpful hints.

- Hold the saw firmly with both hands.
- Avoid placing your hand on the workpiece while making a cut.
- Support the workpiece so that the cut (kerf) is always to your side.
- Support the workpiece near the cut.
- Clamp the workpiece securely so that the workpiece will not move during the cut.
- Always place the saw on the workpiece that is supported, not the “cut off” piece.
- Place the workpiece with the “good” side down.
- Draw a guideline along the desired line of cut before beginning your cut.

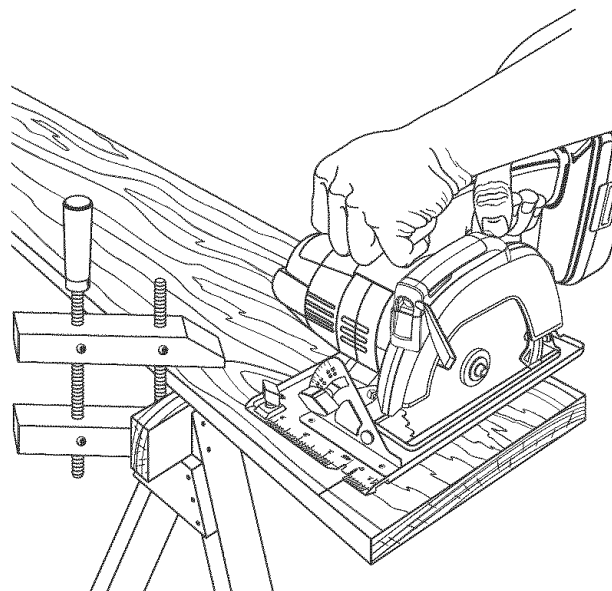

CORRECT

Fig. 17

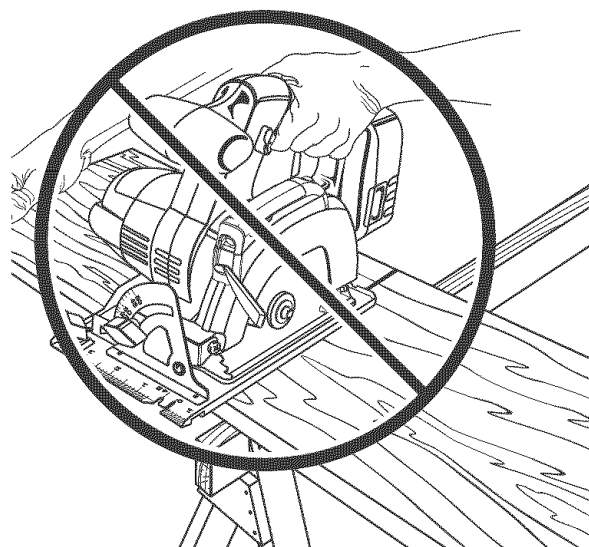

WRONG

Fig. 18

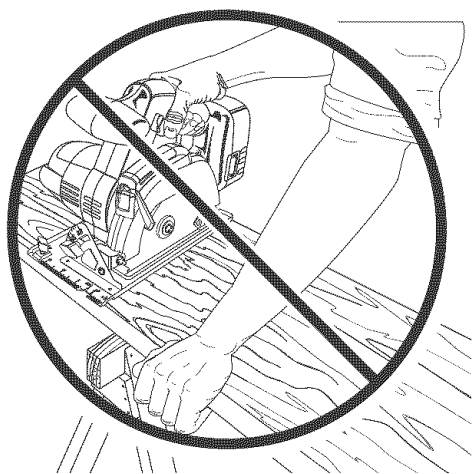

WRONG

Fig. 16

OPERATION

CROSS CUTTING/RIP CUTTING

See Figure 19.

When making a cross cut or rip cut, align the line of cut with the outer blade guide notch on the base as shown in the figure.

Since blade thicknesses vary, always make a trial cut in scrap material along a guideline to determine how much, if any, you must offset the guideline to produce an accurate cut.

NOTE: The distance from the line of cut to the guideline is the amount you should offset the guide.

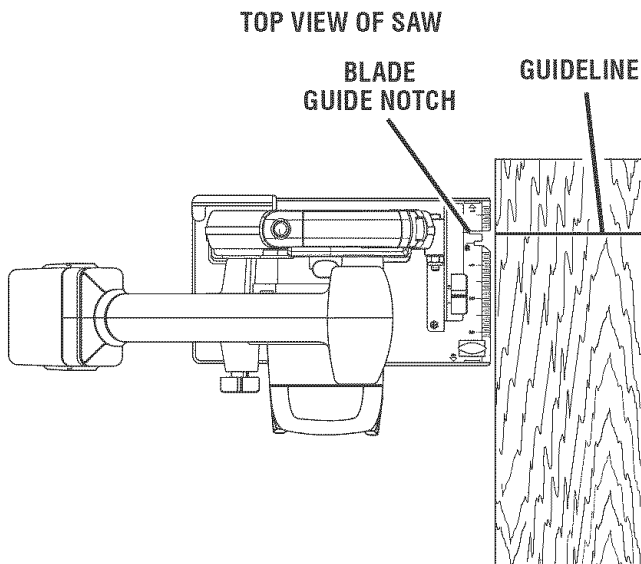

ALIGN OUTER BLADE GUIDE NOTCH ON SAW BASE WITH LINE OF CUT AS SHOWN WHEN MAKING CROSS CUTS OR RIP CUTS

Fig. 19

TO RIP CUT WITHOUT EDGE GUIDE

See Figure 20.

Use a guide when making long or wide rip cuts with the saw.

Follow these directions to rip cut:

- Secure the workpiece.
- Clamp a straight edge to the workpiece using C-clamps.
- Saw along the straight edge to achieve a straight rip cut.

NOTE: Do not bind the blade in the cut.

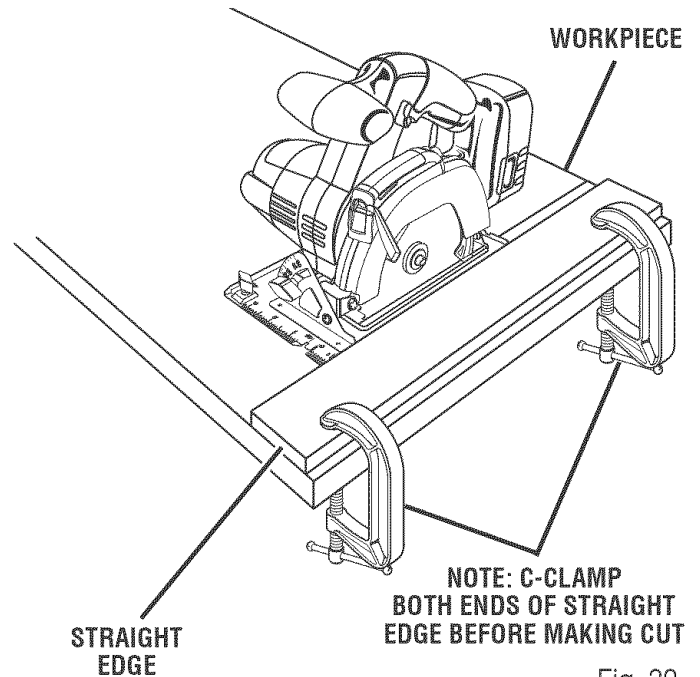

Fig. 20

TO RIP CUT WITH EDGE GUIDE

See Figure 21.

Follow these directions to use the edge guide:

- Secure the workpiece.
- Position the face of the edge guide firmly against the edge of workpiece.
- Guide the saw along the edge to achieve a straight rip cut.

NOTE: The guiding edge of the workpiece must be straight for your cut to be straight. Use caution to prevent the blade from binding in the cut.

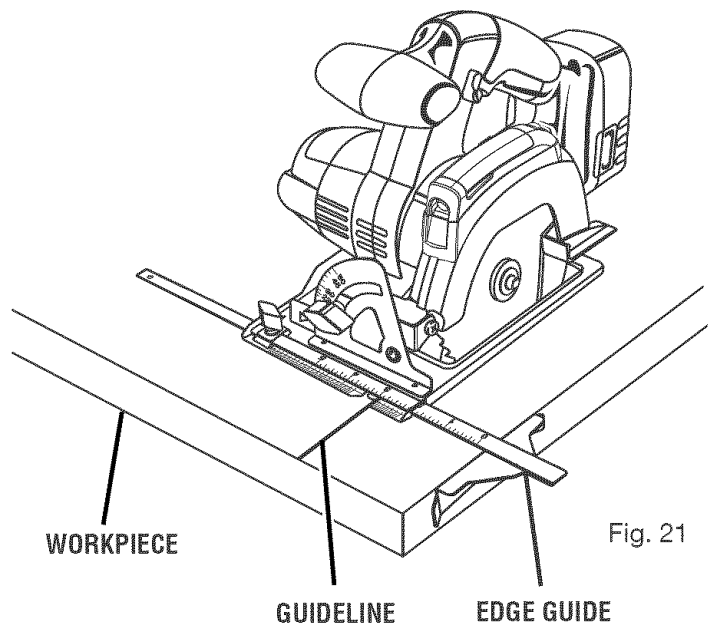

Fig. 21

OPERATION

BEVEL CUTTING

See Figures 22 - 24.

To make the best possible cut, follow these helpful hints:

- Align the line of cut with the inner blade guide notch on the base when making 45° bevel cuts.
- Make a trial cut in scrap material along a guideline to determine how much you should offset the guideline on the cutting material.
- Adjust the angle of the cut to any desired setting between zero and 51.5°. Refer to "To Adjust Bevel Setting" next.

NOTE: When making bevel cuts, you may need to re-adjust laser (See "Adjusting the Laser.")

TO ADJUST BEVEL SETTING

See Figure 23

Follow these directions to adjust the bevel setting:

- Remove battery pack from your trim saw.

⚠ WARNING: Failure to remove battery pack from the tool could result in accidental starting causing serious injury.

- Loosen bevel adjustment knob.
- Raise motor housing end of saw until you reach desired angle setting on bevel scale.
- Tighten bevel adjustment knob securely.

⚠ WARNING: Attempting a bevel cut without having the bevel adjustment knob securely tightened can result in serious injury.

TO BEVEL CUT

See Figure 24.

Follow these directions to bevel cut:

- Hold the saw firmly with both hands as shown.
- Rest the front edge of the base on the workpiece.
- Start the saw and let the blade reach full speed.
- Guide the saw into the workpiece and make the cut.
- Release the trigger and allow the blade to come to a complete stop.
- Lift the saw from the workpiece.

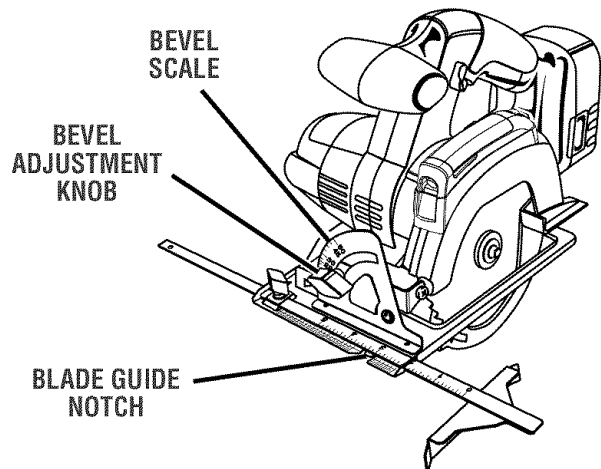
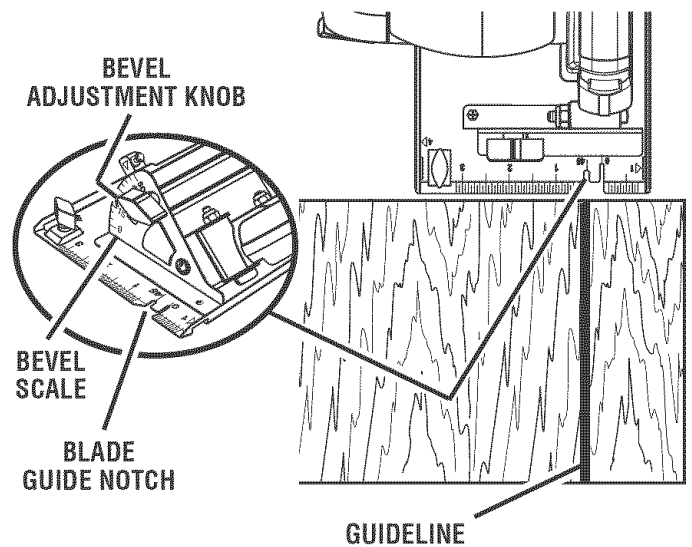

Fig. 22



ALIGN INNER BLADE GUIDE NOTCH ON SAW BASE WITH LINE OF CUT AS SHOWN WHEN MAKING 45° BEVEL CUTS

Fig. 23

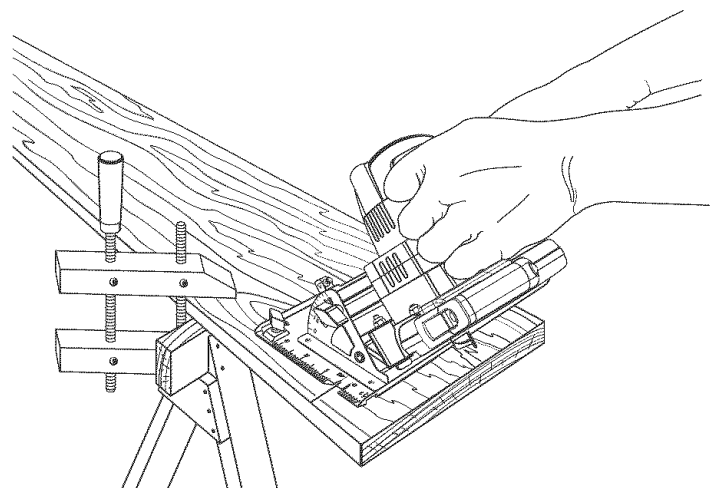

Fig. 24

OPERATION

POSITIVE 0° BEVEL STOP

See Figure 25.

The saw has a positive 0° bevel stop that has been factory adjusted to assure 0° angle of the saw blade when making 90° cuts.

TO CHECK POSITIVE 0° BEVEL STOP

Follow these directions to check the positive 0° bevel stop:

- Remove battery pack from your trim saw.

⚠ WARNING: Failure to remove battery pack from the tool could result in accidental starting causing serious injury.

- Place the saw in an upside down position on a workbench.
- Check the squareness of the saw blade to the base of the saw using a carpenter's square.

TO ADJUST POSITIVE 0° BEVEL STOP

Follow these directions to adjust the positive 0° bevel stop:

- Remove battery pack from your trim saw.

⚠ WARNING: Failure to remove battery pack from the tool could result in accidental starting causing serious injury.

- Loosen bevel adjustment knob.
- Turn setscrew with hex key and adjust base until it is square with the saw blade.
- Tighten bevel adjustment knob securely.

⚠ WARNING: Attempting a bevel cut without having the bevel adjustment knob securely tightened can result in serious injury.

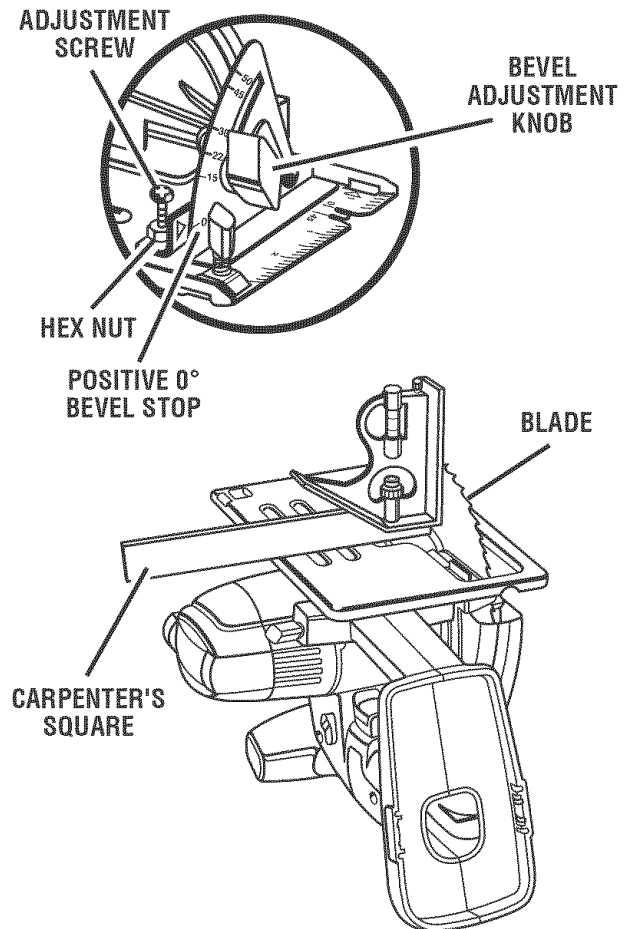

Fig. 25

OPERATION

POCKET CUTTING

See Figure 26.

WARNING: Always adjust bevel setting to zero before making a pocket cut. Attempting a pocket cut at any other setting can result in loss of control of the saw possibly causing serious injury.

Follow these directions to pocket cut:

- Adjust the bevel setting to zero.
- Set the blade to the correct blade depth setting.
- Swing the lower blade guard up using the lower blade guard handle.

NOTE: Always raise the lower blade guard with the handle to avoid serious injury.

- Hold the lower blade guard by the handle.
- Rest the front of the base flat against the workpiece with the rear of the handle raised so the blade does not touch the workpiece.
- Start the saw and let the blade reach full speed.
- Guide the saw into the workpiece and make the cut.

WARNING: Always cut in a forward direction when pocket cutting. Cutting in the reverse direction could cause the saw to climb up on the workpiece and back toward you.

- Release the trigger and allow the blade to come to a complete stop.
- Lift the saw from the workpiece.
- Clear corners out with a hand saw or sabre saw.

WARNING: Never tie the lower blade guard in a raised position. Leaving the blade exposed could lead to serious injury.

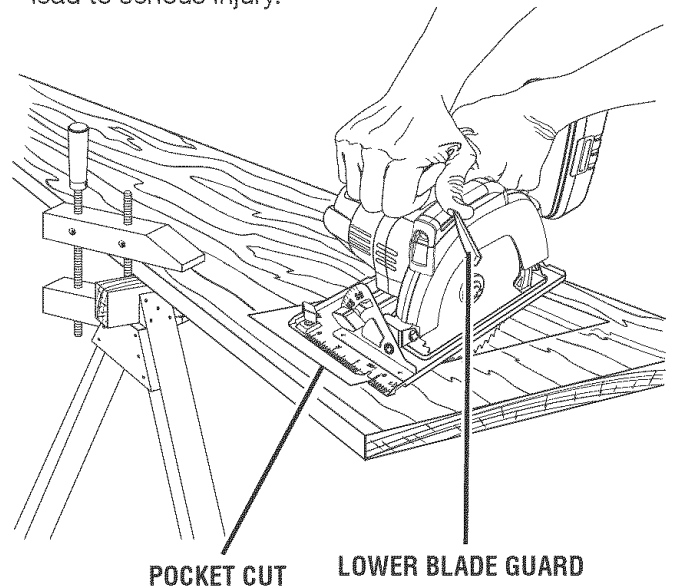

Fig. 26

ADJUSTMENTS

WARNING: Before performing any adjustment, make sure the battery pack is removed from tool. Failure to heed this warning could result in serious personal injury.

ADJUSTING THE LASER

See Figure 27.

NOTE: Draw a pencil line on a scrap workpiece parallel to the long edge of the base as a straight line guide to aid in the adjusting process.

- Remove battery pack from your trim saw.
- Make sure laser is turned off.
- Remove the laser cover by lifting it off its base.
- Turn laser on.
- Loosen the screw inside laser.
- Rest the front of the base on scrap workpiece.
- Adjust the laser beam with the mark on the scrap workpiece by loosening the screw to the laser aperture and slowly moving laser guide left or right.
- Since blade thicknesses vary, always make a trial cut in scrap workpiece to ensure an accurate cut.
- Once alignment is achieved tighten the screw.
- Replace the laser cover.
- Check for proper alignment.
- Repeat as necessary until laser is aligned.

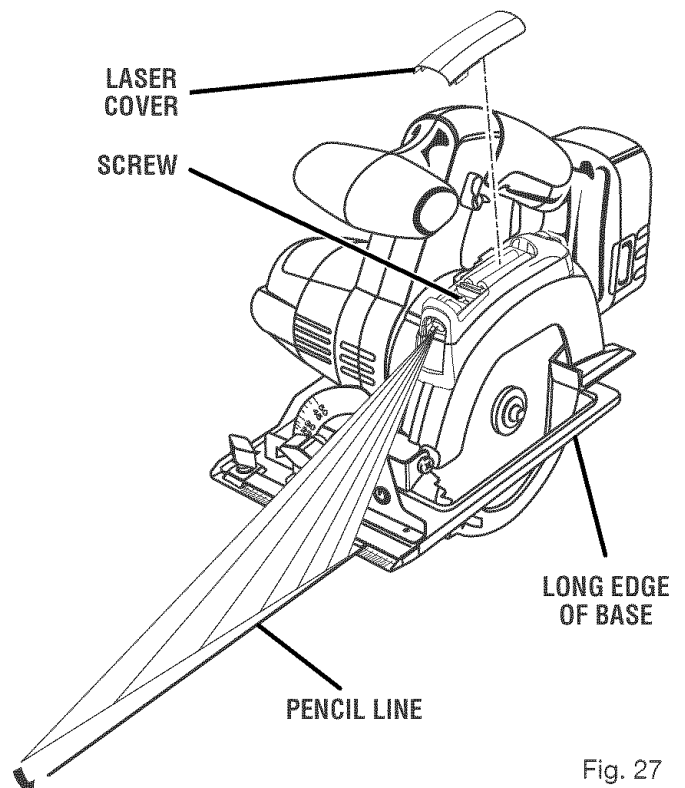

Fig. 27

MAINTENANCE

⚠ WARNING: When servicing use only identical Craftsman replacement parts. Use of any other parts may create a hazard or cause product damage.

⚠ WARNING: Always wear safety goggles or safety glasses with side shields during power tool operation or when blowing dust. If operation is dusty, also wear a dust mask.

GENERAL MAINTENANCE

Avoid using solvents when cleaning plastic parts. Most plastics are susceptible to damage from various types of commercial solvents and may be damaged by their use. Use clean cloths to remove dirt, dust, oil, grease, etc.

⚠ WARNING: Do not at any time let brake fluids, gasoline, petroleum-based products, penetrating oils, etc., come in contact with plastic parts. Chemicals can damage, weaken or destroy plastic which may result in serious personal injury.

Electric tools used on fiberglass material, wallboard, spackling compounds, or plaster are subject to accelerated wear and possible premature failure because the fiberglass chips and grindings are highly abrasive to bearings, brushes, commutators, etc. Consequently, we do not recommended using this tool for extended work on these types of materials. However, if you do work with any of these materials, it is extremely important to clean the tool using compressed air.

LUBRICATION

All of the bearings in this tool are lubricated with a sufficient amount of high grade lubricant for the life of the unit under normal operating conditions. Therefore, no further lubrication is required.

REPLACING LASER GUIDE BATTERIES

See Figure 28.

- Remove battery pack from saw.
- Make sure laser is turned off.
- Remove the laser cover by lifting it off its base.
- Remove both AAA batteries.
- Install the two AAA batteries aligning the positives (+) with positives (+) and the negatives (-) with negatives (-) as shown on the inside base of laser.
- Replace the laser cover.
- Turn on laser.

⚠ CAUTION: Use of controls or adjustments or performance other than those specified herein may result in hazardous radiation exposure.

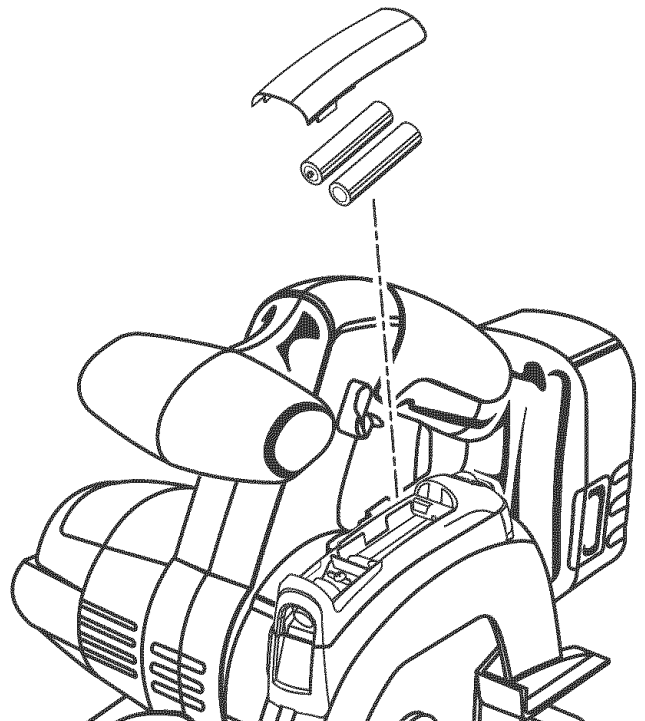
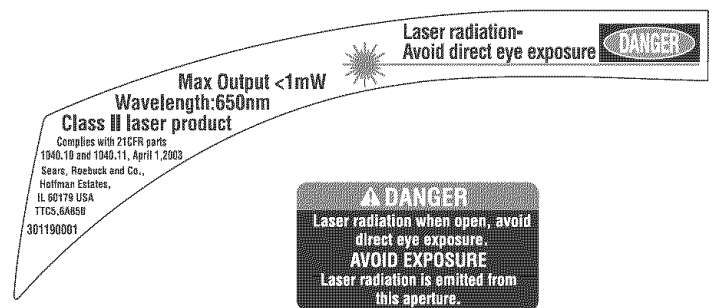

Fig. 28

MAINTENANCE

BATTERIES

The battery pack for this tool is equipped with nickel-cadmium rechargeable batteries. Length of service from each charging will depend on the type of work you are doing.

The batteries in this tool have been designed to provide maximum trouble-free life. However, like all batteries, they will eventually wear out. **Do not** disassemble battery pack and attempt to replace the batteries. Handling of these batteries, especially when wearing rings and jewelry, could result in a serious burn.

To obtain the longest possible battery life, we suggest the following:

- Remove the battery pack from the charger once it is fully charged and ready for use.

For battery pack storage longer than 30 days:

- Store the battery pack where the temperature is below 80°F.
- Store battery packs in a "discharged" condition.

BATTERY PACK REMOVAL AND PREPARATION FOR RECYCLING



To preserve natural resources, please recycle or dispose of batteries properly.

This product contains nickel-cadmium batteries. Local, state or federal laws may prohibit disposal of nickel-cadmium batteries in ordinary trash.

Consult your local waste authority for information regarding available recycling and/or disposal options.

- ▲ **WARNING:** Upon removal, cover the battery pack's terminals with heavy duty adhesive tape. Do not attempt to destroy or disassemble battery pack or remove any of its components. Nickel-cadmium batteries must be recycled or disposed of properly. Also, never touch both terminals with metal objects and/or body parts as short circuit may result. Keep away from children. Failure to comply with these warnings could result in fire and/or serious injury.

ACCESSORIES

The following recommended accessories are currently available at Sears retail stores:

- 5-1/2 in. Thin Kerf Blade

- ▲ **WARNING:** Current attachments and accessories available for use with this tool are listed above. Do not use any attachments or accessories not recommended by the manufacturer of this tool. The use of attachments or accessories not recommended can result in serious personal injury.

CRAFTSMAN 19.2 VOLT CORDLESS TRIM SAW – MODEL NUMBER 315.115160

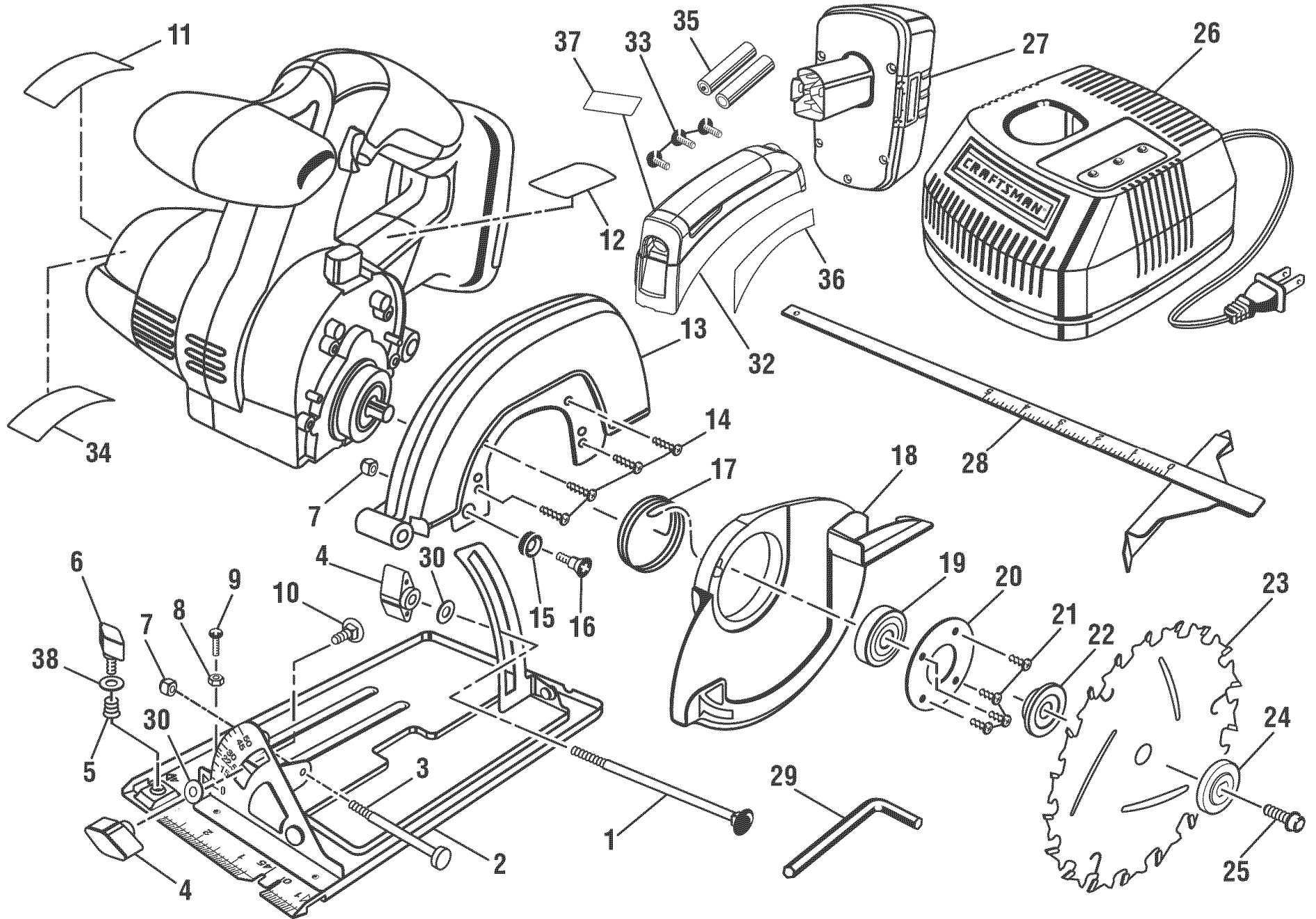

25

CRAFTSMAN 19.2 VOLT CORDLESS TRIM SAW – MODEL NUMBER 315.115160

The model number will be found on a plate attached to the motor housing. Always mention the model number in all correspondence regarding your **CORDLESS TRIM SAW** or when ordering repair parts.

SEE BACK PAGE FOR PARTS ORDERING INSTRUCTIONS

PARTS LIST

KEY NO.	PART NUMBER	DESCRIPTION	QTY.	KEY NO.	PART NUMBER	DESCRIPTION	QTY.
1	6614301	* Carriage bolt (M6 X 100 mm).....	1	21	6620104	* Screw (M2.6 X 10 mm Pan Hd.)	4
2	3025516	Base Assembly	1	22	6112004	Inner Blade Washer	1
3	6614501	* Screw (M6 X 16 mm Hex Hd.)	1	23	***	Saw Blade	1
4	5224502	Knob	2	24	6112101	Outer Blade Washer	1
5	680001001	Spring	1	25	6614401	Blade Screw	1
6	520177002	Wing Screw	1	26	1425301	Charger (**Item No. 911041).....	1
7	6797401	* Lock Nut (M5)	2	27	1323903	Battery Pack (**Item No. 911375)	1
8	6802201	Hex Nut.....	1		1323517	Battery Pack (**Item No. 911375)	1
9	6621204	* Screw (M4 X 16 mm Pan Hd.)	1	28	670957001	Edge guide	1
10	660142001	* Carriage Bolt (M6 X 12 mm)	1	29	6800201	Blade Wrench (5 mm Hex Key).....	1
11	9427205	Logo Plate	1	30	5228001	Washer.....	2
12	9429817	Warning Label.....	1	31	300912141	Carrying Case - Not Shown	1
13	640556011	Upper Blade Guard	1	32	301014002	Laser Guide Assembly.....	1
14	6620803	* Screw (M4 X 22 mm Pan Hd.)	4	33	660212031	* Screw (M4 X 8 mm Washer Hd).....	3
15	5217802	Bumper.....	1	34	940271022	Data Plate	1
16	6619302	* Screw (M5 X 15.5 mm)	1	35	750273001	* Battery	2
17	6867201	Torsion Spring.....	1	36	940214082	Laser Data Plate	1
18	550994005	Lower Blade Guard.....	1	37	940230081	Laser Warning.....	1
19	6807001	Ball Bearing (Ntn #6000zz)	1	38	680027001	Washer.....	1
20	6850303	Bearing Retainer.....	1		983000490	Operator's Manual	

- * Standard Hardware Item – May Be Purchased Locally
- ** Can Be Purchased Thru RSOS (Retail Special Order System)
- *** Complete Assortment Available At Your Nearest Sears Retail Store

