

# General Instructions

## Installation: (B-0805)

1. Turn off water supply and drain lines. Flush lines thoroughly of debris.
2. Drill a 7/8" diameter hole through sink or countertop in desired location.
3. Remove no.10, no.9 and no.8 from no.7. Place no.7 through opening in sink.
4. Replace no.8, no.9 and no.10 onto no.7 and tighten against bottom of sink. Hold no.2 flat against sink while tightening no.9.
5. Connect water supply to no.10 and check for leaks.

**Note: Flow is adjustable from instantaneous shut-off to extended flow by external adjustment:**

*Note: Each 238A is preset at the factory with 40psi inlet water pressure. They may be reset at installation. If water pressure varies, the cycle time will also vary. Recommended cycle time is 10-20 seconds.*

**Note: See separate installation instructions 098-009763-45 for models with spreader unit. (B-0806 and B-0808)**

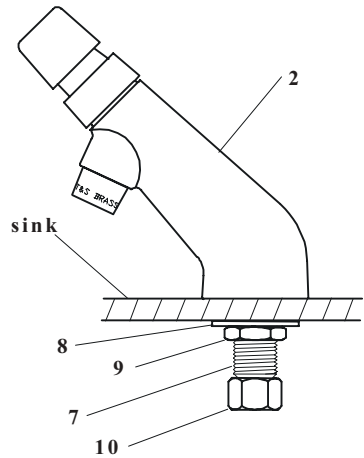

## Disassembly for cartridge adjustment:

1. Remove cap from cartridge by unscrewing set screw (with 5/64" hex key) from cap.

1/8 turn increments  
clockwise for longer  
flow time



1/8 turn increments  
counter-clockwise for  
shorter flow time

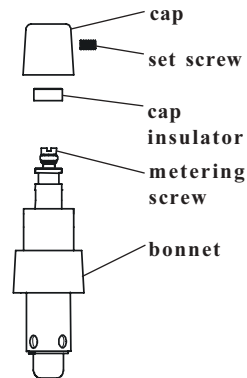

**Note: See installation instruction 098-003150-45 for cartridge adjustment.**