

Operator's Manual

CRAFTSMAN®

PRO SERIES

SNOW BLOWER

Model Nos. 247.88870*
247.88874*
247.88976*
247.88978*

*-- Last digit of model number varies

CRAFTSMAN®

SNOW BLOWER

Model Nos. 247.88394*
247.88396*
247.88640*
247.88781*
247.88789*
247.88794*

* -- Last digit of model number varies

CAUTION: Before using this product, read this manual and follow all safety rules and operating instructions.

NOTE: The terms "snow thrower" and "snow blower" may be used interchangeably for this product.

- SAFETY
- UNPACKING
- ASSEMBLY
- OPERATION
- MAINTENANCE
- ESPAÑOL

Sears Brands Management Corporation, Hoffman Estates, IL 60179, U.S.A.

Used under license

Visit our website: www.craftsman.com



Form No. 769-15950
(July 26, 2018)

TABLE OF CONTENTS

Safe Operation Practices	Page 3	Off-Season Storage.....	Page 36
Assembly	Page 7	Troubleshooting	Page 37
Operation	Page 21	Warranty Statement.....	See Separate Supplement
Service & Maintenance.....	Page 28	Español.....	Page 39

PRODUCT SPECIFICATIONS

Engine Oil:	5W-30
Fuel:	Unleaded Gasoline
Spark Plug:	F6RTC (Sears Part #951-10292)
Spark Plug Gap:	.020" to 0.030"

MODEL NUMBER

Model Number _____
Serial Number _____
Date of Purchase _____

Record the model number, serial number,
and date of purchase above.



SAFETY INSTRUCTIONS

WARNING

This symbol points out important safety instructions which, if not followed, could endanger the personal safety and/or property of yourself and others. Read and follow all instructions in this manual before attempting to operate this machine. Failure to comply with these instructions may result in personal injury. When you see this symbol, HEED ITS WARNING!

WARNING

CALIFORNIA PROPOSITION 65

Engine Exhaust, some of its constituents, and certain vehicle components contain or emit chemicals known to State of California to cause cancer and birth defects or other reproductive harm.

DANGER

This machine was built to be operated according to the safe operation practices in this manual. As with any type of power equipment, carelessness or error on the part of the operator can result in serious injury. This machine is capable of amputating fingers, hands, toes and feet and throwing debris. Failure to observe the following safety instructions could result in serious injury or death.

WARNING

Your Responsibility—Restrict the use of this power machine to persons who read, understand and follow the warnings and instructions in this manual and on the machine.

SAVE THESE INSTRUCTIONS!

NOTE: The terms “snow thrower” and “snow blower” may be used interchangeably for this product.

TRAINING

- Read, understand, and follow all instructions on the machine and in the manual(s) before attempting to assemble and operate. Failure to do so can result in serious injury to the operator and/or bystanders. Keep this manual in a safe place for future and regular reference and for ordering replacement parts.
- Be familiar with all controls and their proper operation. Know how to stop the machine and disengage them quickly.
- Never allow children under 14 years of age to operate this machine. Children 14 and over should read and understand the instructions and safe operation practices in this manual and on the machine and be trained and supervised by an adult.
- Never allow adults to operate this machine without proper instruction.
- Thrown objects can cause serious personal injury. Plan your snow-throwing pattern to avoid discharge of material toward roads, bystanders and the like.
- Keep bystanders, pets and children at least 75 feet from the machine while it is in operation. Stop machine if anyone enters the area.
- Exercise caution to avoid slipping or falling, especially when operating in reverse.

PREPARATION

- Thoroughly inspect the area where the equipment is to be used. Remove all doormats, newspapers, sleds, boards, wires and other foreign objects, which could be tripped over or thrown by the auger/impeller.
- Always wear safety glasses or eye shields during operation and while performing an adjustment or repair to protect your eyes. Thrown objects which ricochet can cause serious injury to the eyes.
- Do not operate without wearing adequate winter outer garments. Do not wear jewelry, long scarves or other loose clothing, which could become entangled in moving parts. Wear footwear which will improve footing on slippery surfaces.

- Use a grounded three-wire extension cord and receptacle for all machines with electric start engines.
- Disengage all control levers before starting the engine.
- Adjust collector housing height to clear gravel or crushed rock surfaces.
- Never attempt to make any adjustments while engine is running, except where specifically recommended in the operator’s manual.
- Let engine and machine adjust to outdoor temperature before starting to clear snow.

Safe Handling of Gasoline:

To avoid personal injury or property damage use extreme care in handling gasoline. Gasoline is extremely flammable and the vapors are explosive. Serious personal injury can occur when gasoline is spilled on yourself or your clothes which can ignite. Wash your skin and change clothes immediately.

- Use only an approved gasoline container.
- Never fill containers inside a vehicle or on a truck or trailer bed with a plastic liner. Always place containers on the ground away from your vehicle before filling.
- When practical, remove gas-powered equipment from the truck or trailer and refuel it on the ground. If this is not possible, then refuel such equipment on a trailer with a portable container, rather than from a gasoline dispenser nozzle.
- Keep the nozzle in contact with the rim of the fuel tank or container opening at all times until fueling is complete. Do not use a nozzle lock-open device.
- Extinguish all cigarettes, cigars, pipes and other sources of ignition.
- Never fuel machine indoors.
- Never remove gas cap or add fuel while the engine is hot or running. Allow engine to cool at least two minutes before refueling.
- Never over fill fuel tank. Fill tank to no more than ½ inch below bottom of filler neck to allow space for fuel expansion.
- Replace gasoline cap and tighten securely.

SAFETY INSTRUCTIONS

- If gasoline is spilled, wipe it off the engine and equipment. Move unit to another area. Wait 5 minutes before starting the engine. If fuel is spilled on clothing, change clothing immediately.
- To reduce fire hazards, keep machine free of grass, leaves, or other debris build-up. Clean up oil or fuel spillage and remove any fuel soaked debris.
- Never store the machine or fuel container inside where there is an open flame, spark or pilot light as on a water heater, space heater, furnace, clothes dryer or other gas appliances.

OPERATION

- Do not put hands or feet near rotating parts, in the auger/impeller housing or chute assembly. Contact with the rotating parts can amputate hands and feet.
- The auger/impeller control lever is a safety device. Never bypass its operation. Doing so makes the machine unsafe and may cause personal injury.
- The control levers must operate easily in both directions and automatically return to the disengaged position when released.
- Never operate with a missing or damaged chute assembly. Keep all safety devices in place and working.
- Never run an engine indoors or in a poorly ventilated area. Engine exhaust contains carbon monoxide, an odorless and deadly gas.
- Do not operate machine while under the influence of alcohol or drugs.
- Muffler and engine become hot and can cause a burn. Do not touch. Keep children away.
- Exercise extreme caution when operating on or crossing gravel surfaces. Stay alert for hidden hazards or traffic.
- Exercise caution when changing direction and while operating on slopes. Do not operate on steep slopes.
- Plan your snow-throwing pattern to avoid discharge towards windows, walls, cars etc. Thus, avoiding possible property damage or personal injury caused by a ricochet.
- Never direct discharge at children, bystanders and pets or allow anyone in front of the machine.
- Do not overload machine capacity by attempting to clear snow at too fast of a rate.
- Never operate this machine without good visibility or light. Always be sure of your footing and keep a firm hold on the handles. Walk, never run.
- Disengage power to the auger/impeller when transporting or not in use.
- Never operate machine at high transport speeds on slippery surfaces. Look down and behind and use care when backing up.
- After striking a foreign object or if the machine should start to vibrate abnormally, stop the engine, disconnect the spark plug wire and ground it against the engine. Inspect thoroughly for damage. Repair any damage before starting and operating.

- Disengage all control levers and stop engine before you leave the operating position (behind the handles). Wait until the auger/impeller comes to a complete stop before unclogging the chute assembly, making any adjustments, or inspections.
- Never put your hand in the discharge or collector openings. Do not unclog chute assembly while engine is running. Shut off engine and remain behind handles until all moving parts have stopped before unclogging.
- Use only attachments and accessories approved by the manufacturer (e.g. wheel weights, tire chains, cabs etc.).
- When starting engine, pull cord slowly until resistance is felt, then pull rapidly. Rapid retraction of starter cord (kickback) will pull hand and arm toward engine faster than you can let go. Broken bones, fractures, bruises or sprains could result.
- If situations occur which are not covered in this manual, use care and good judgment.

CLEARING A CLOGGED DISCHARGE CHUTE

Hand contact with the rotating impeller inside the discharge chute is the most common cause of injury associated with snow throwers. Never use your hand to clean out the discharge chute.

To clear the chute:

- a. SHUT THE ENGINE OFF!
- b. Wait 10 seconds to be sure the impeller blades have stopped rotating.
- c. Always use a clean-out tool, not your hands.

MAINTENANCE & STORAGE

- Never tamper with safety devices. Check their proper operation regularly. Refer to the maintenance and adjustment sections of this manual.
- Before cleaning, repairing, or inspecting machine disengage all control levers and stop the engine. Wait until the auger/impeller come to a complete stop. Disconnect the spark plug wire and ground against the engine to prevent unintended starting.
- Check bolts and screws for proper tightness at frequent intervals to keep the machine in safe working condition. Also, visually inspect machine for any damage.
- Do not change the engine governor setting or over-speed the engine. The governor controls the maximum safe operating speed of the engine.
- Snow thrower shave plates and skid shoes are subject to wear and damage. For your safety protection, frequently check all components and replace with original equipment manufacturer's (OEM) parts only as listed in the Parts pages of this operator's manual. Use of parts which do not meet the original equipment specifications may lead to improper performance and compromise safety!
- Check control levers periodically to verify they engage and disengage properly and adjust, if necessary. Refer to the adjustment section in this operator's manual for instructions.
- Maintain or replace safety and instruction labels, as necessary.

SAFETY INSTRUCTIONS

- Observe proper disposal laws and regulations for gas, oil, etc. to protect the environment.
- Prior to storing, run machine a few minutes to clear snow from machine and prevent freeze up of auger/impeller.
- Never store the machine or fuel container inside where there is an open flame, spark or pilot light such as a water heater, furnace, clothes dryer etc.
- Always refer to the operator's manual for proper instructions on off-season storage.
- Check fuel line, tank, cap, and fittings frequently for cracks or leaks. Replace if necessary.
- Do not crank engine with spark plug removed.
- According to the Consumer Products Safety Commission (CPSC) and the U.S. Environmental Protection Agency (EPA), this product has an *Average Useful Life* of seven (7) years, or 60 hours of operation. At the end of the *Average Useful Life* have the machine inspected annually by an authorized service dealer to ensure that all mechanical and safety systems are working properly and not worn excessively. Failure to do so can result in accidents, injuries or death.

DO NOT MODIFY ENGINE

To avoid serious injury or death, do not modify engine in any way. Tampering with the governor setting can lead to a runaway engine and cause it to operate at unsafe speeds. Never tamper with factory setting of engine governor.







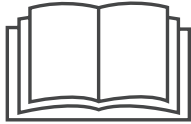

NOTICE REGARDING EMISSIONS

Engines which are certified to comply with California and federal EPA emission regulations for SORE (Small Off Road Equipment) are certified to operate on regular unleaded gasoline, and may include the following emission control systems: Engine Modification (EM), Oxidizing Catalyst (OC), Secondary Air Injection (SAI) and Three Way Catalyst (TWC) if so equipped.

SAFETY INSTRUCTIONS

SAFETY SYMBOLS

This page depicts and describes safety symbols that may appear on this product. Read, understand, and follow all instructions on the machine before attempting to assemble and operate.

Symbol	Description
	READ THE OPERATOR'S MANUAL(S) Read, understand, and follow all instructions in the manual(s) before attempting to assemble and operate.
	WARNING— ROTATING BLADES Keep hands out of inlet and discharge openings while machine is running. There are rotating blades inside.
	WARNING— ROTATING BLADES Keep hands out of inlet and discharge openings while machine is running. There are rotating blades inside.
	WARNING— ROTATING AUGER Do not put hands or feet near rotating parts, in the auger/impeller housing or chute assembly. Contact with the rotating parts can amputate hands and feet.
	WARNING—THROWN OBJECTS This machine may pick up and throw and objects which can cause serious personal injury.
	WARNING— GASOLINE IS FLAMMABLE Allow the engine to cool at least two minutes before refueling.
	WARNING— CARBON MONOXIDE Never run an engine indoors or in a poorly ventilated area. Engine exhaust contains carbon monoxide, an odorless and deadly gas.
	WARNING— ELECTRICAL SHOCK Do not use the engine's electric starter in the rain.
	WARNING— HOT SURFACE Engine parts, especially the muffler, become extremely hot during operation. Allow engine and muffler to cool before touching.



WARNING: Your Responsibility—Restrict the use of this power machine to persons who read, understand and follow the warnings and instructions in this manual and on the machine.

SAVE THESE INSTRUCTIONS!

ASSEMBLY

NOTE: This Operator's Manual covers several models. Features may vary by model. Not all features in this manual are applicable to all models and the model depicted may differ from yours. Refer to Figure 1 which shows the different versions and match the contents of carton (chute and directional control rod/flex shaft) to identify your specific unit.

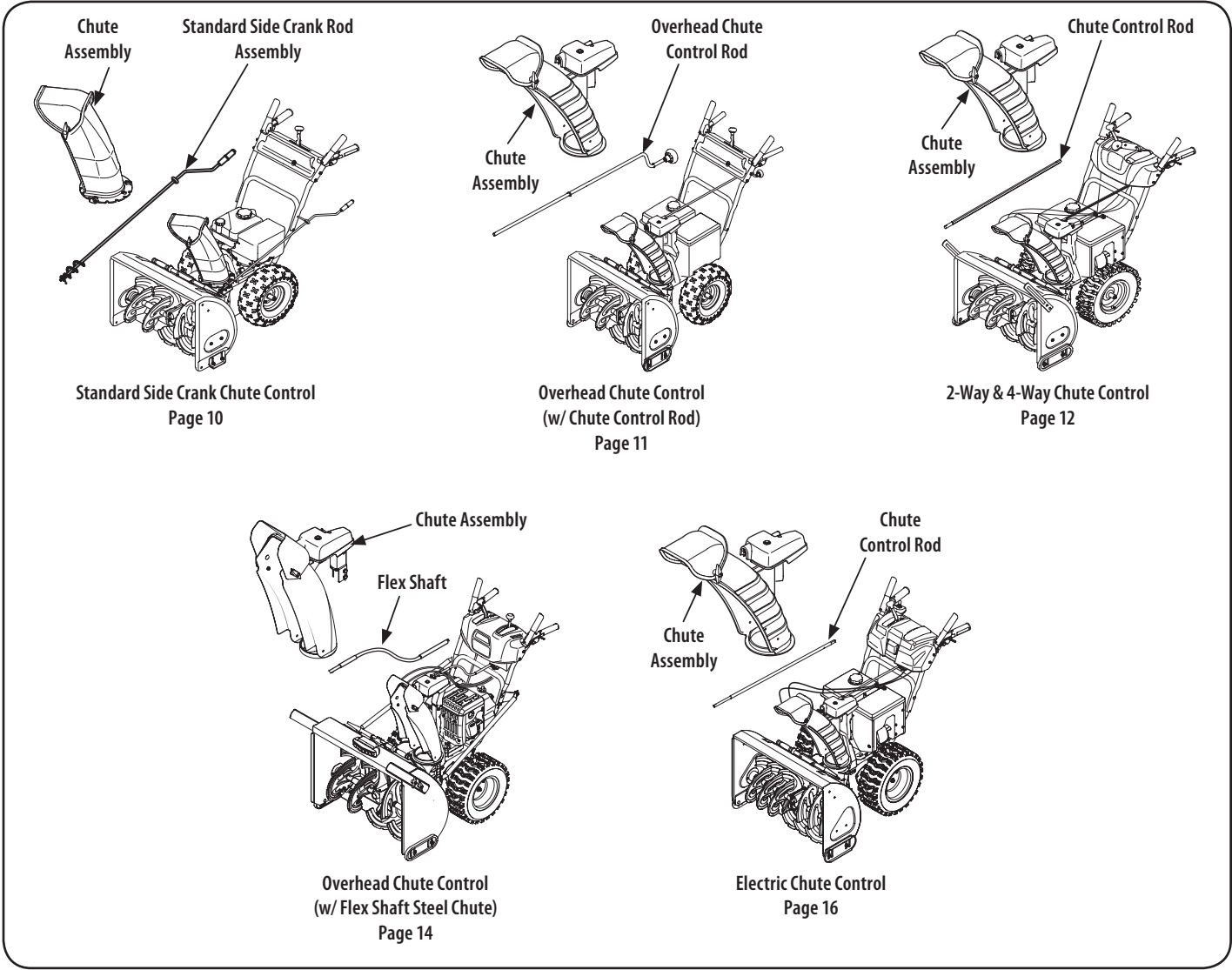

Figure 1



ASSEMBLY

NOTE: References to right or left side of the snow blower are determined from behind the unit in the operating position (standing directly behind the snow blower, facing the handle panel).

UNPACKING: Removing From Carton

1. Cut the corners of the carton and lay the sides flat on the ground. Remove and discard all packing inserts.
2. Move the snow blower out of the carton.
3. Make certain the carton has been completely emptied before discarding it.

Handle Assembly

Refer to Figure 1 and proceed to your applicable chute style.

1. Cut cable ties securing chute control rod or upper handle to the lower handle (if applicable), set aside the chute control rod (if applicable) and remove the wrap around the handles (if applicable).

NOTE: Do not cut the cable tie securing the cables to the engine for units equipped.

NOTE: On units with Overhead Chute Control, Four-Way Chute Control, and Electric Chute Control cut cable ties securing flex shaft to the lower handle and set the flex shaft aside. Remove rubber bands securing cables to carriage screws and cut cable tie securing shift rod to lower handle. Refer to Figure to help identify your unit.

2. Observe the lower rear area of the snow blower to be sure both cables are aligned with roller guides before pivoting the handle upward. See Figure 2.

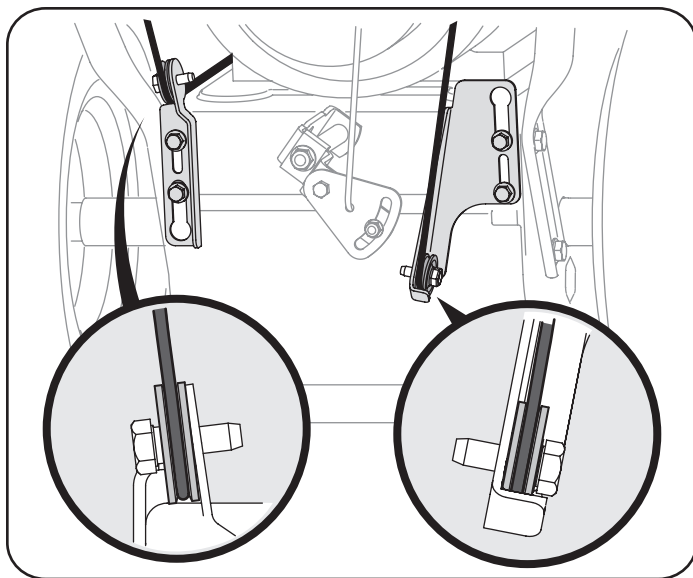

Figure 2

3. Loosen the top two lock nuts securing the upper and lower handle and remove the two carriage screws from the lower handle and set aside. See Figure 3 or Figure 4 for units with side supports.

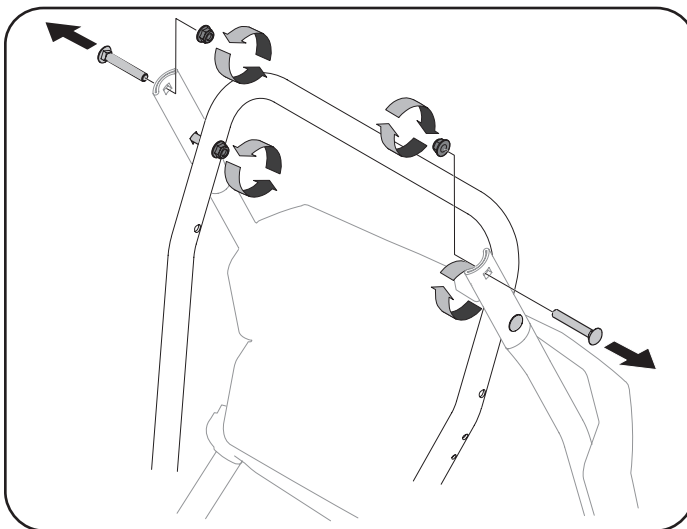

Figure 3

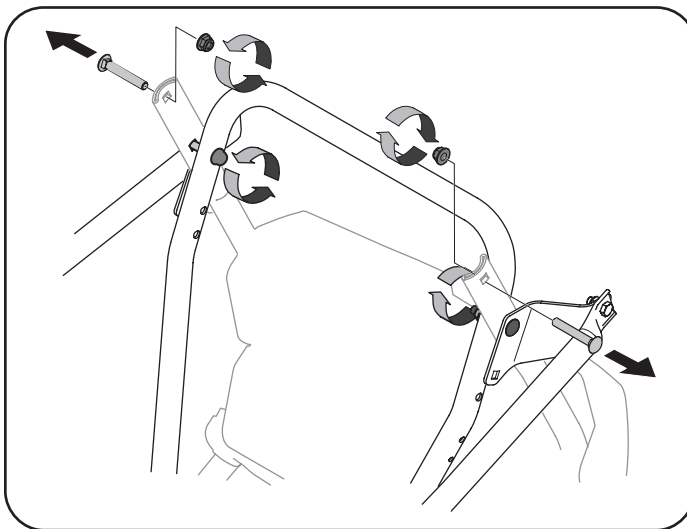

Figure 4

ASSEMBLY

- Place shift lever in Forward-6 position or fastest forward speed (if equipped).
- Pull up and back on upper handle as shown in Figure 5. As you are raising the handle upward, make sure that both ends of the center cable are positioned properly in the brackets. Align upper handle with the lower handle.

NOTE: On select units with steel rod speed selectors, you may need to lower shift rod to the side slightly to maneuver handle panel over it when pivoting handle upward.

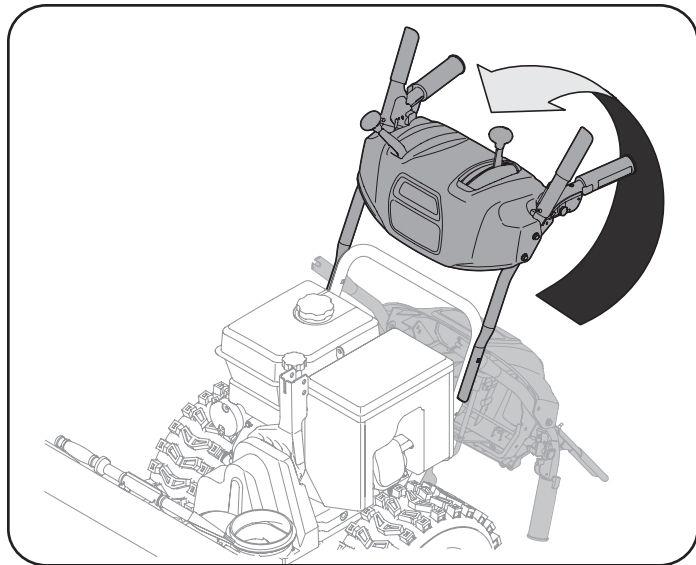

Figure 5

- Attach the two carriage screws and lock nuts removed in Step 2. Finish securing the handle by tightening the top two lock nuts loosened in Step 2. See Figure 6 or Figure 7 for units with side supports.

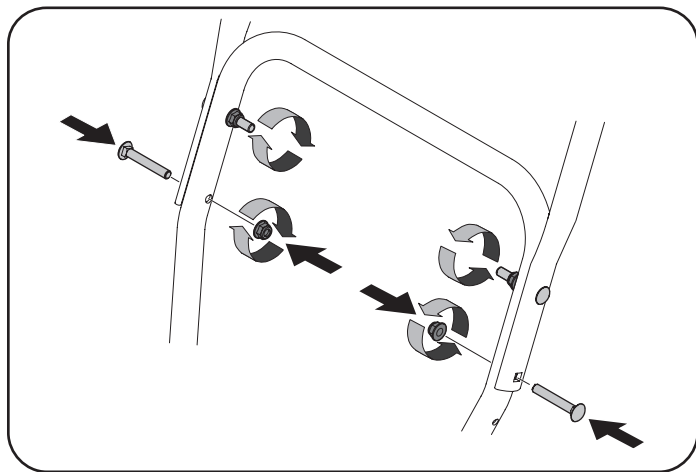

Figure 6

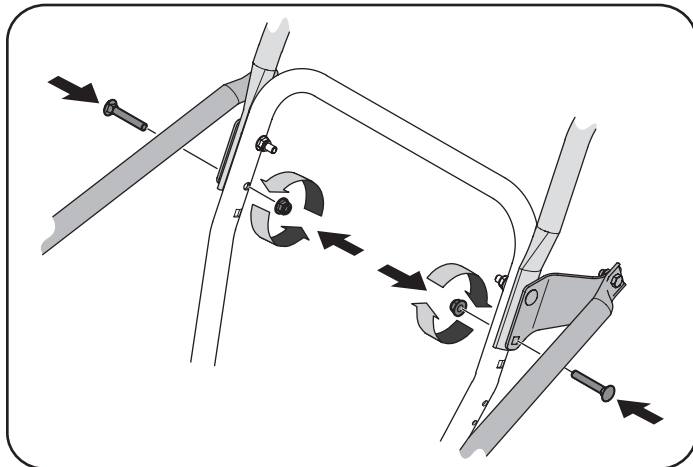

Figure 7

- Remove and discard any rubber bands, if present. They are for packaging purposes only.
- On units equipped with cable guides on top of the engine, check that all cables are properly routed through the cable guide. Then pull the cables towards the chute and pull the cable tie on the engine snug on the cables to secure in place.

NOTE: For smoothest operation, cables should all be to the left of the chute directional control rod.



STOP

Refer to Figure 1 to identify your applicable chute style and continue to Chute Assembly Options (page 9).

Chute Assembly Options

Refer to Figure 1 and proceed to your applicable Chute Control Style on pages 10-17.

ASSEMBLY

Standard Side Crank Chute Control

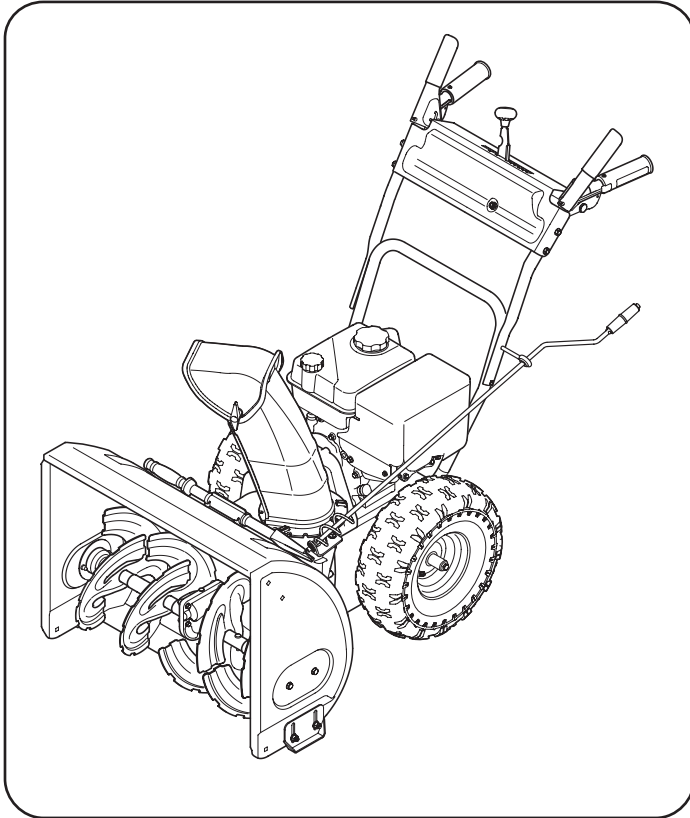

Figure 8

1. Position chute assembly over base. See Figure 9.

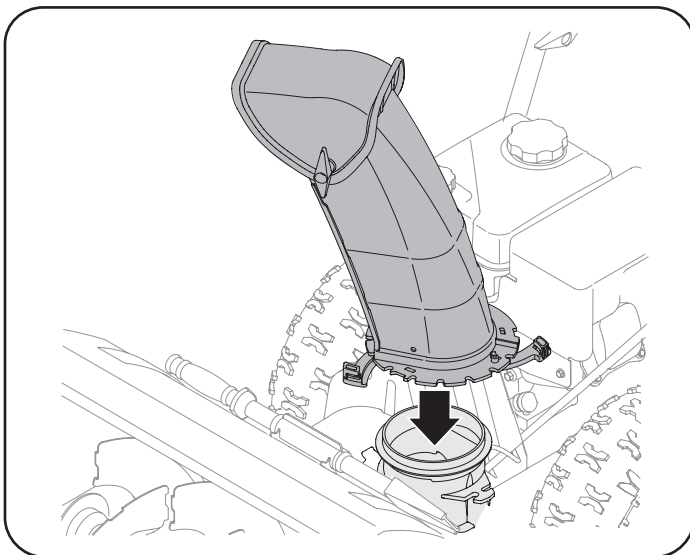

Figure 9

2. Close flange keepers to secure chute assembly to chute base. Flange keepers will click into place when properly secure. See Figure 10.

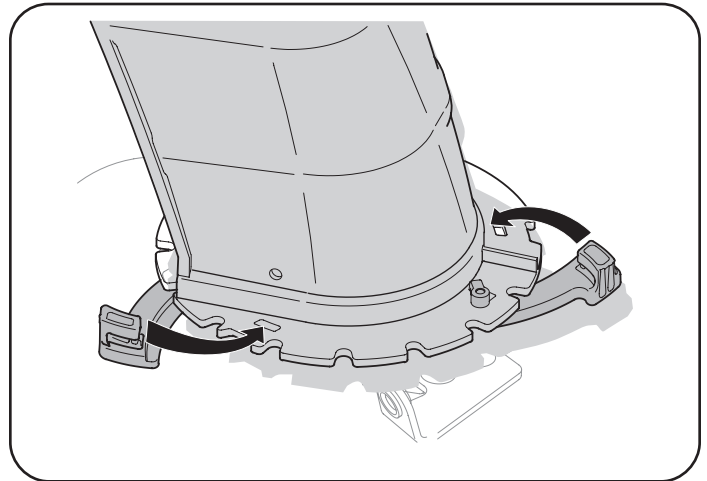

Figure 10

NOTE: Ensure the lower chute is secured to the flange on the chute base. The lower edge of the chute keeper should be positioned below the flange on the chute base after being clicked into place. If flange keepers will not easily click into place, use palm of your hand to apply swift, firm pressure to the back of each.

Chute Directional Control Assembly

1. Remove plastic cap (if present), flat washer and hairpin clip from end of chute directional control assembly. See Figure 11.

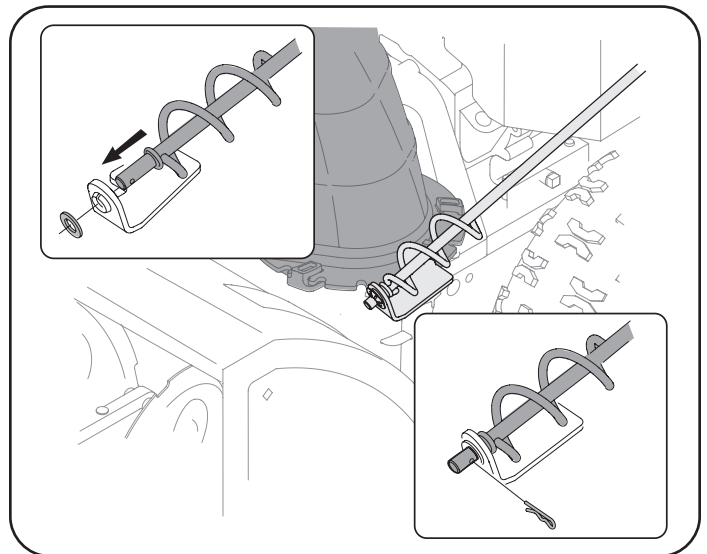

Figure 11

2. Insert end of chute directional control assembly into lower bracket and secure chute directional control assembly with flat washer and hairpin clip removed in Step 1. If necessary, lower bracket can be adjusted. Refer to Chute Bracket Adjustment in Service section on page 32.



Continue to Set-Up (page 18).

ASSEMBLY

Overhead Chute Control (w/ Chute Control Rod)

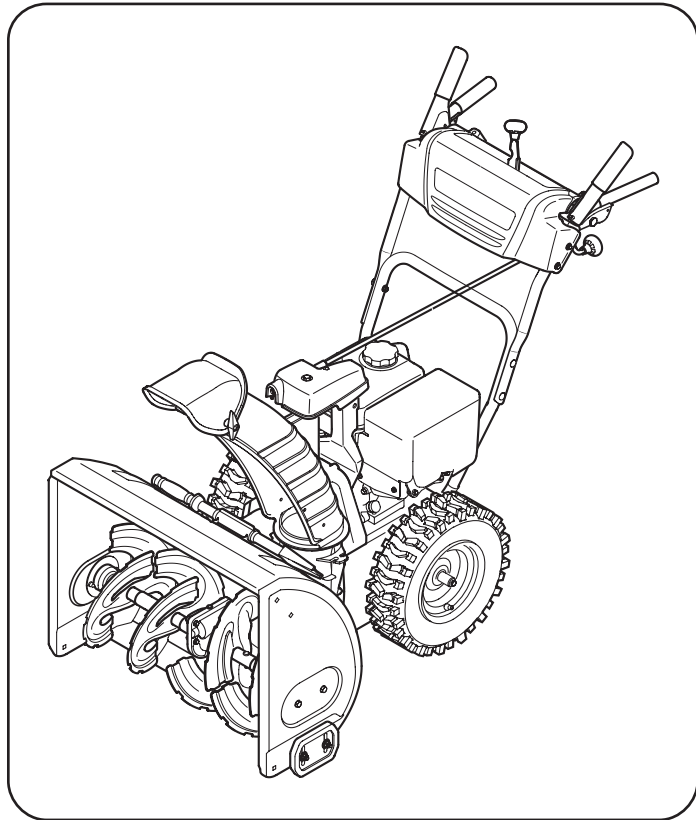

Figure 12

1. Remove wing nut and hex screw from chute control head and clevis pin and cotter pin from chute support bracket. Position chute assembly (forward-facing) over chute base. See Figure 13.

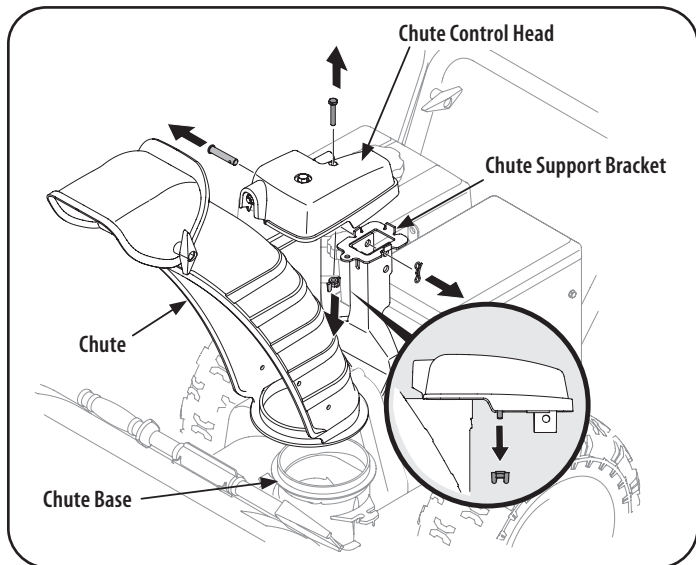

Figure 13

2. Place chute assembly onto chute base and secure chute control head to chute support bracket with clevis pin and cotter pin removed in Step 1. See Figure 14.

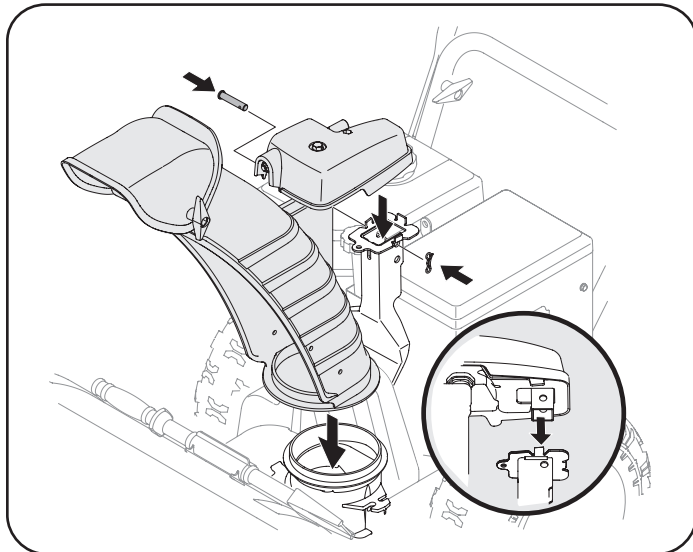

Figure 14

3. Finish securing chute control head to chute support bracket with wing nut (a) and hex screw (b) removed in Step 1. See Figure 15.

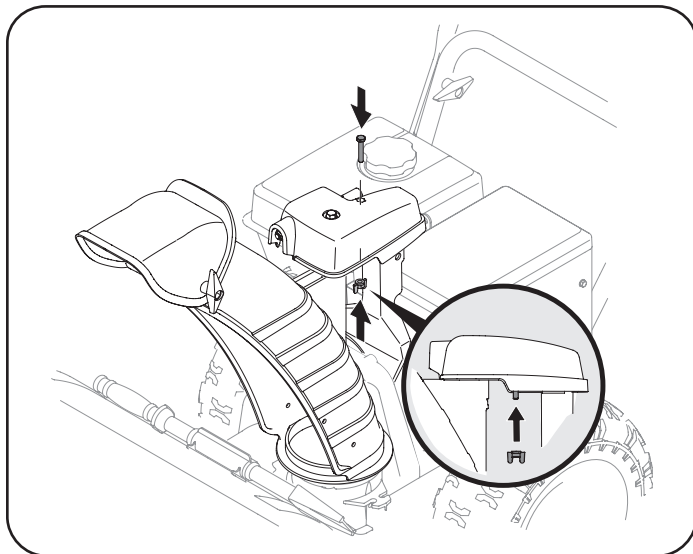

Figure 15

ASSEMBLY

4. Insert chute control rod into the support bracket on rear of the dash panel. See Figure 16.

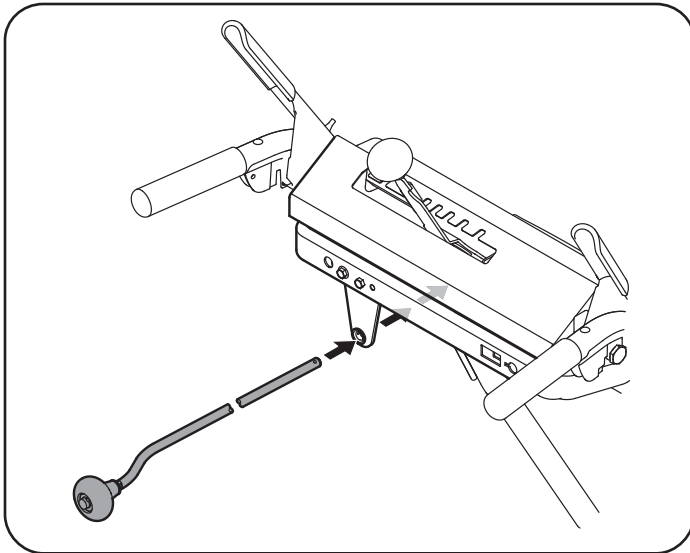

Figure 16

5. Remove hairpin clip (a) from rear of chute control head. See Figure 17.

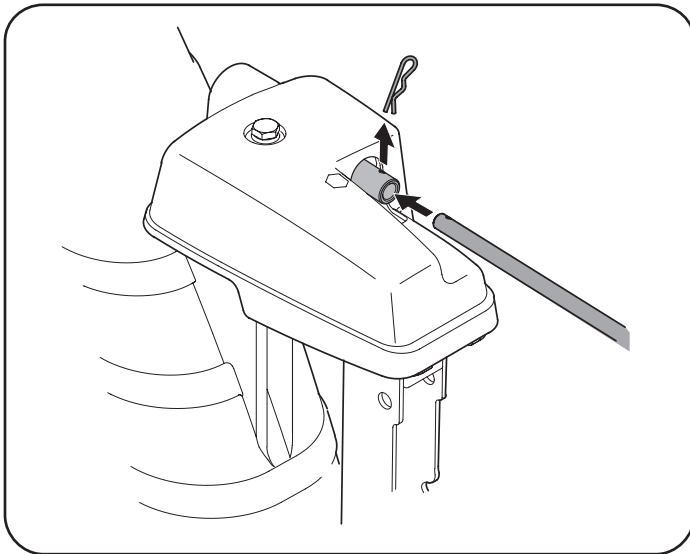

Figure 17

6. Insert chute control rod (b) into rear of chute control head. See Figure 17. Secure chute control rod to chute control assembly with hairpin clip removed in Step 5.

STOP

Continue to Set-Up (page 18).

2-Way & 4-Way Chute Control

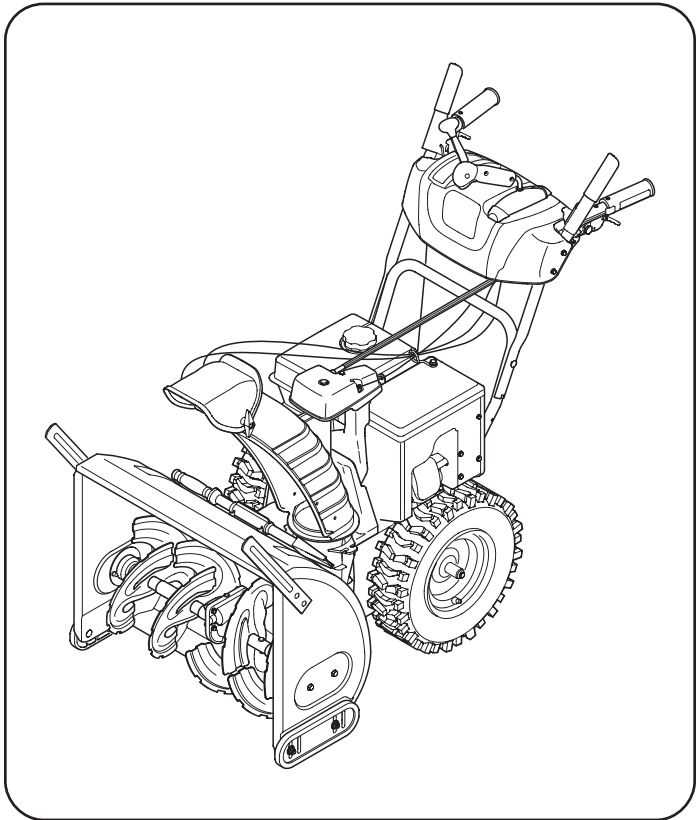

Figure 18

1. Remove hairpin clip, wing nut and hex screw from chute control head and clevis pin and bow-tie cotter pin from chute support bracket. See Figure 19.

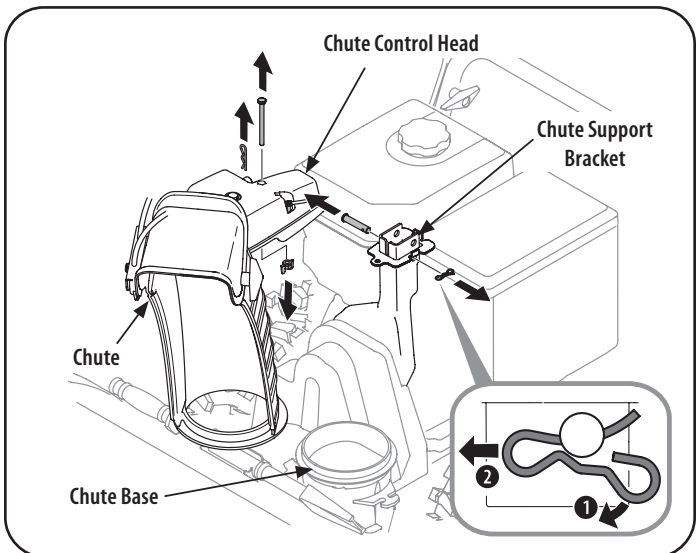

Figure 19

ASSEMBLY

NOTE: For smoothest operation, cables should all be to the left of the chute directional control rod.

2. Insert chute control rod into chute control head. Push rod as far into chute control head as possible, keeping holes in rod pointing upward. See Figure 20.

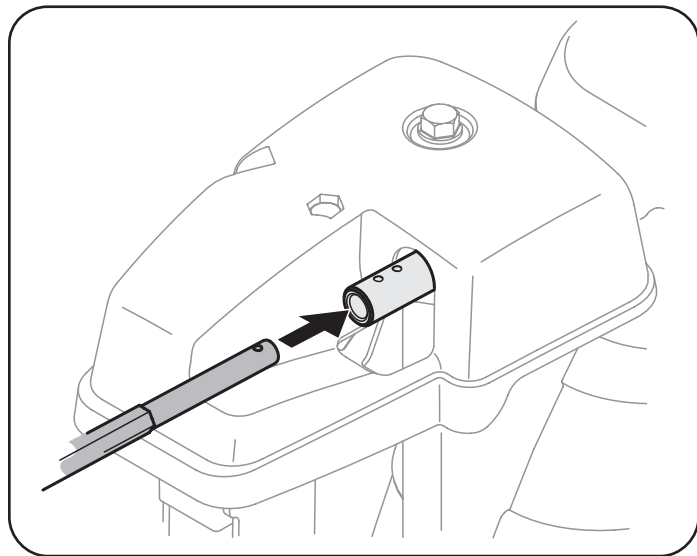

Figure 20

3. Place chute onto chute base and ensure chute control rod is positioned under handle panel. Install hex screw removed in Step 1, but do not secure with wing nut at this time. Figure 21.

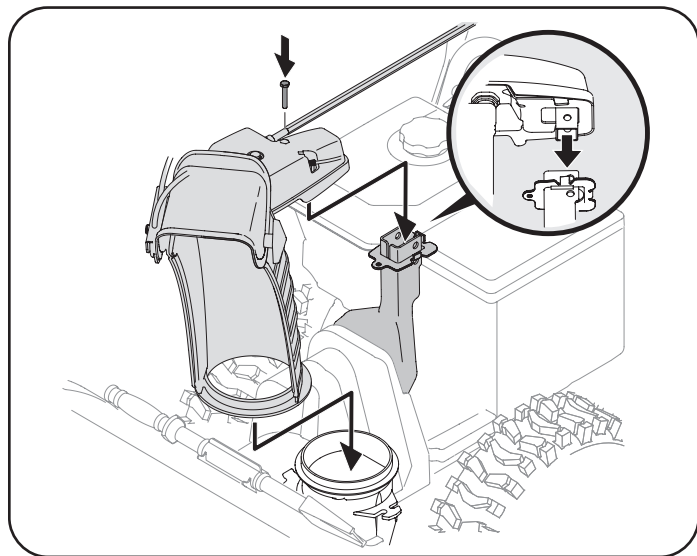

Figure 21

4. Squeeze trigger on joystick and rotate chute by hand to face forward. The holes in chute control input will be facing up. See Figure 22.

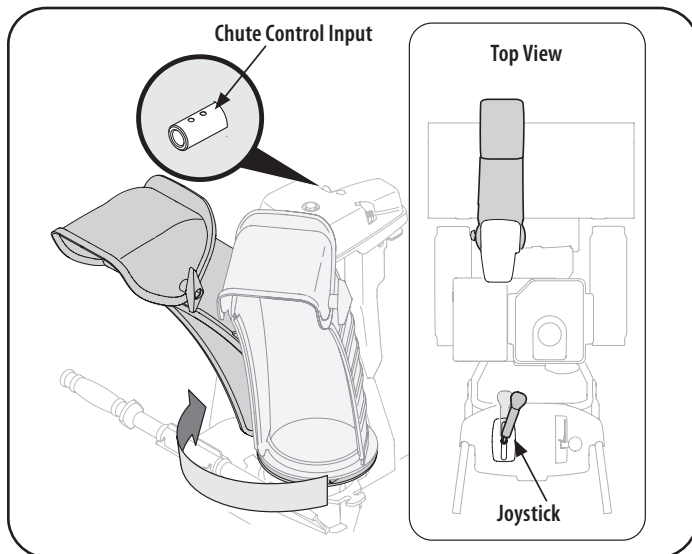

Figure 22

NOTE: Chute will not rotate without squeezing trigger on joystick.

5. Rotate joystick to one o'clock position so that indicator arrow on pinion gear below control panel faces upward. See Figure 23.

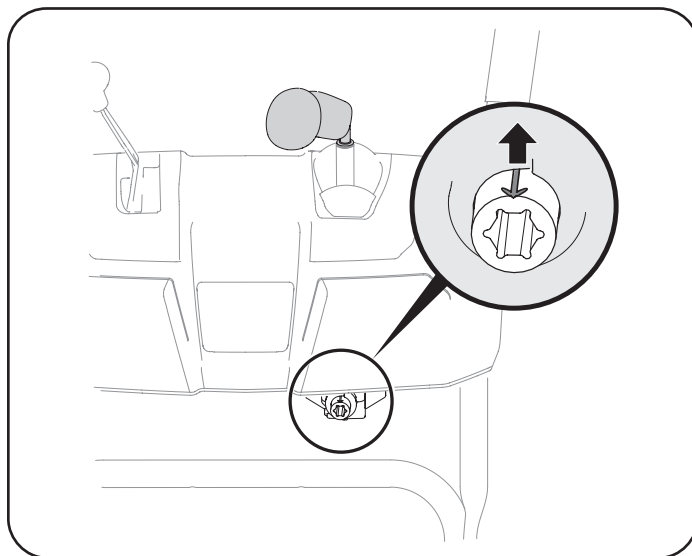

Figure 23

6. Insert chute control rod into pinion gear below joystick. Make sure to line up hole in rod with arrow on pinion gear. See Figure 24.

ASSEMBLY

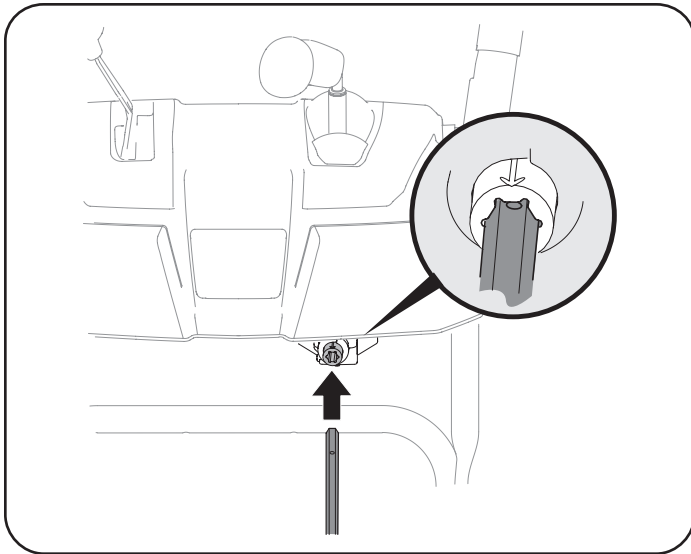

Figure 24

NOTE: Chute control rod will fit snug into pinion gear. Support rear of dash panel with one hand while inserting rod with your other hand to ensure rod is inserted **all the way** into pinion gear.

NOTE: The hole in the chute directional control rod is a reference for aligning rod with indicator arrow on pinion gear, and will be visible after rod has been inserted.

7. Push chute control rod toward control panel until hole in rod lines up with hole in chute control input closest to chute control head and insert hairpin clip (a) removed in Step 1. See Figure 25.

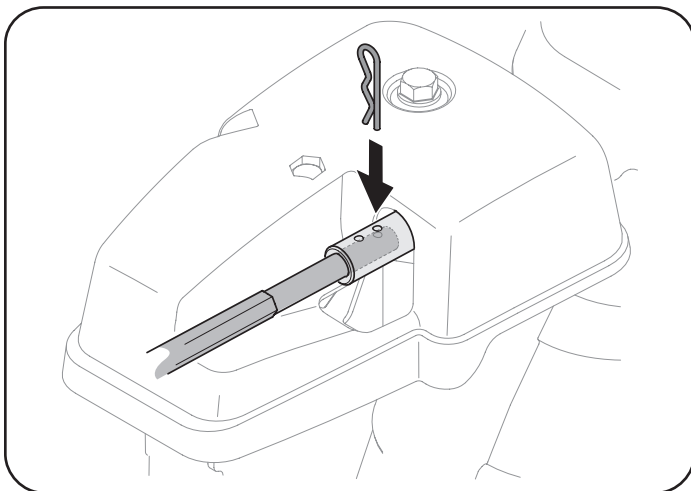

Figure 25

NOTE: Second hole is used to achieve further engagement of chute control rod into pinion gear if required. Refer to Service section for Chute Control Rod adjustments.

8. Finish securing chute control head to chute support bracket with wing nut, clevis pin, and bow-tie cotter pin (e) removed in Step 1.



Continue to Set-Up (page 18).

Overhead Chute Control (w/ Flex Shaft & Steel Chute)

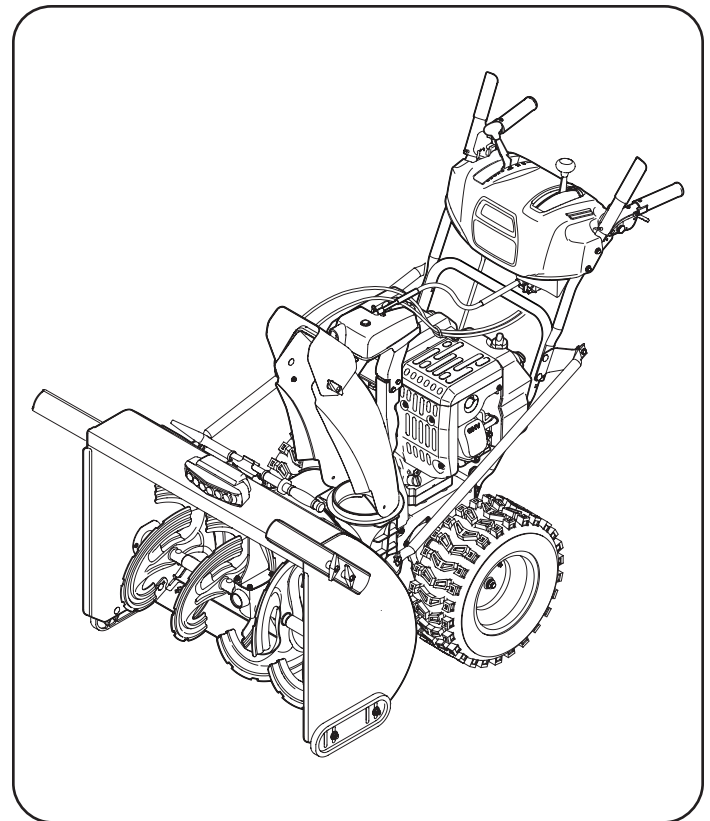

Figure 26

1. Remove lock nuts and hex screws from chute support bracket (this will require two wrenches). See Figure 27.
2. Place chute assembly onto chute base and chute control head onto chute support bracket. See Figure 27.

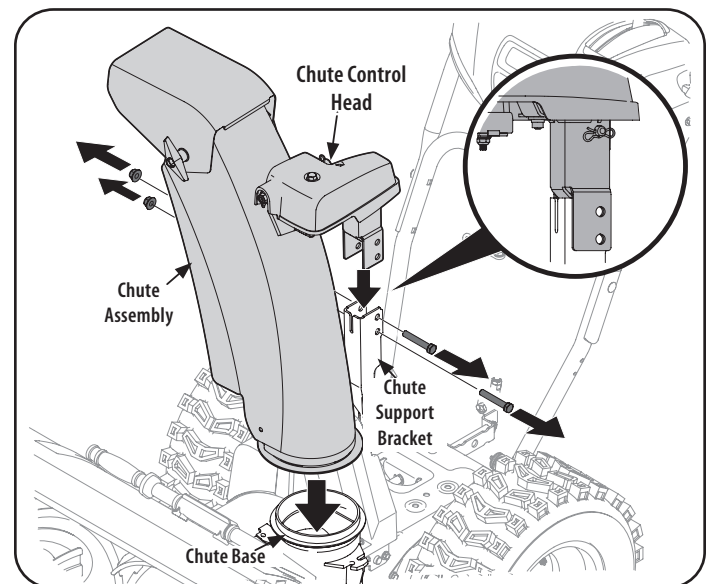

Figure 27

ASSEMBLY

- Secure chute control head to chute support bracket with lock nuts and hex screws removed in Step 1. See Figure 28.

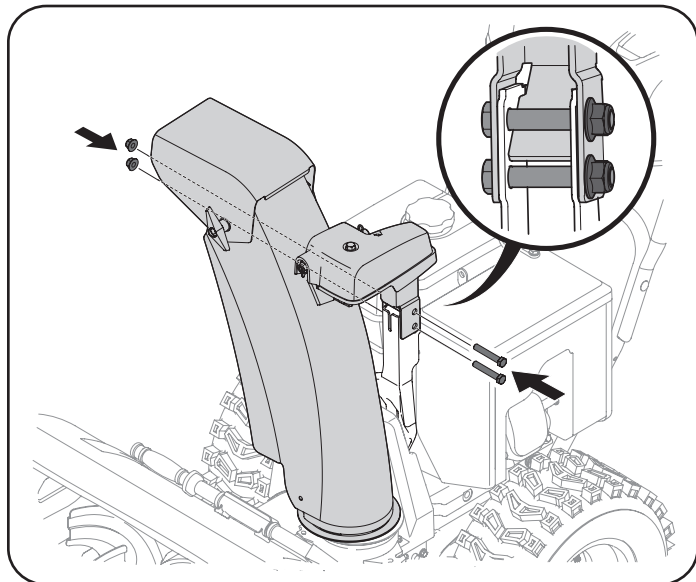

Figure 28

NOTE: For smoothest operation, the cables should all be to the left of the chute control rod.

- Remove hairpin clip from rear of chute control assembly. See Figure 29.

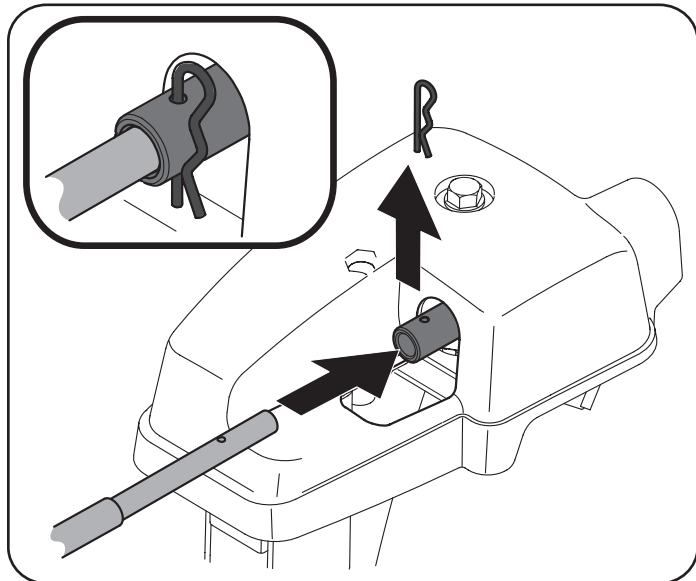

Figure 29

- Insert flex shaft removed during handle assembly from lower handle into rear of chute directional control head. See Figure 29. Secure flex shaft to chute control head with hairpin clip removed in Step 4.

- Insert hex end of flex shaft into chute control rod coupling under dash panel. See Figure 30.

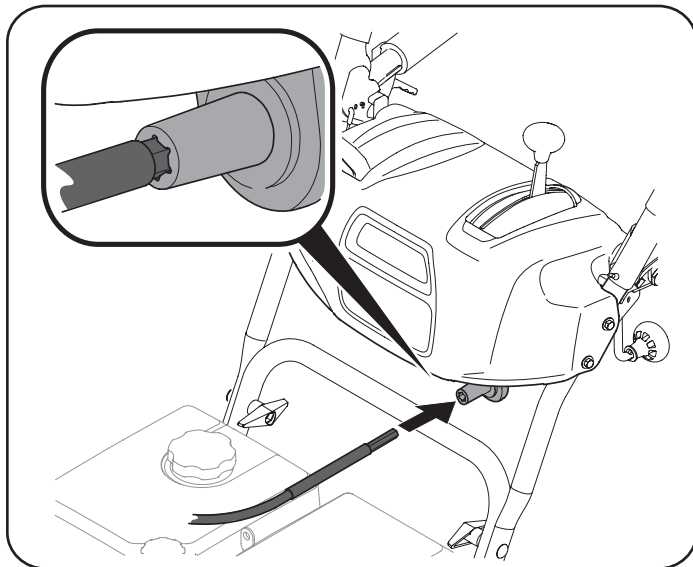

Figure 30

- Ensure speed selector is in fastest forward speed.
- Remove cotter pin and washer from ferrule on end of shift rod. See Figure 31 inset.

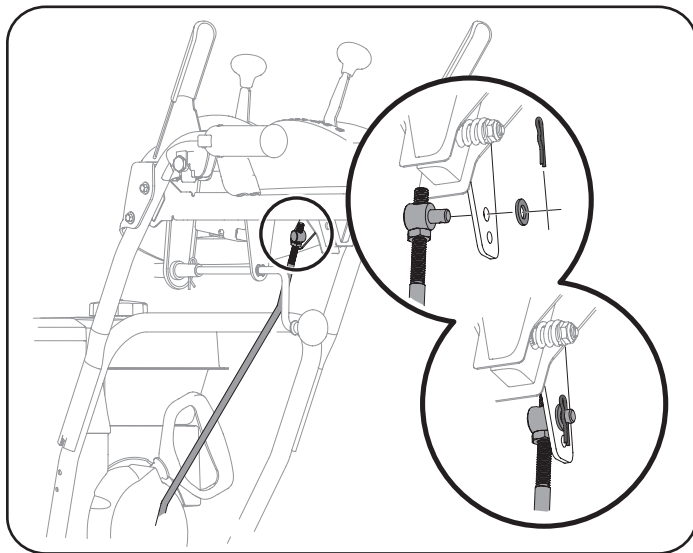

Figure 31

ASSEMBLY

9. Make sure the shift lever on the back of the transmission is rotated downward to the full extent of its rotation. See Figure 32.

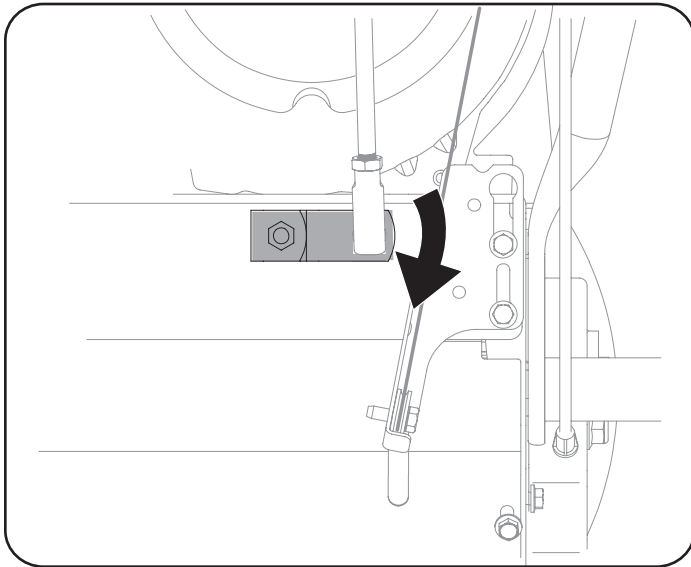

Figure 32

10. Insert ferrule into top hole of shift lever and secure with cotter pin (a) and washer (b) removed in Step 8. See Figure 31. Ferrule may need to be adjusted up or down.



Continue to Set-Up (page 18).

Electric Chute Control

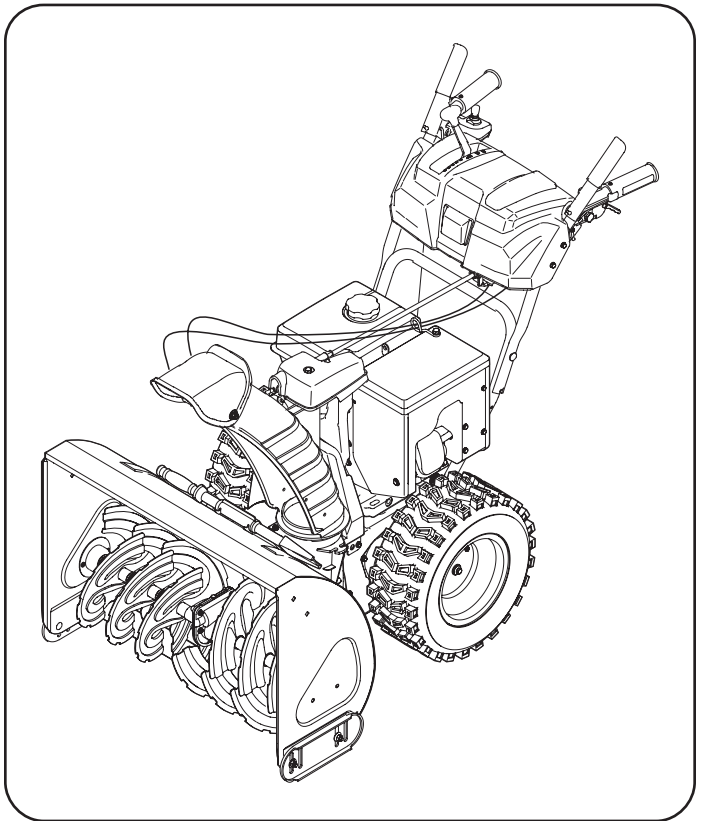

Figure 33

1. Remove cotter pin, wing nut, and hex screw from chute control head and clevis pin and bow-tie cotter pin from chute support bracket. See Figure 34.

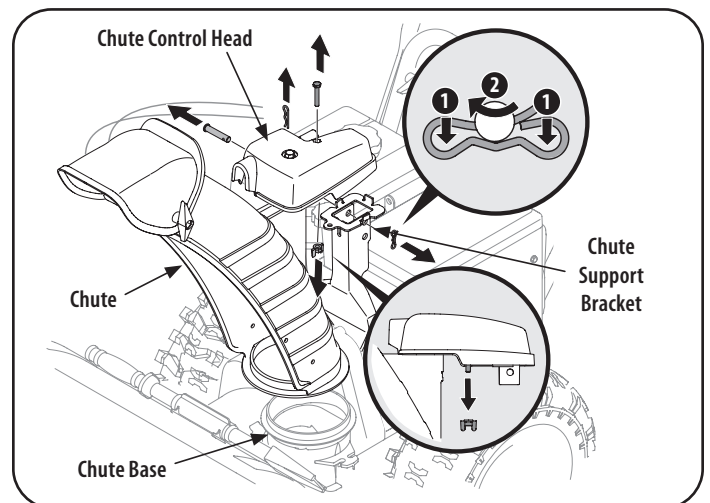

Figure 34

NOTE: For smoothest operation, the cables should all be to the left of the chute control rod.

ASSEMBLY

2. Insert the round end of the chute control rod into input of chute control head. Push rod as far into the chute control head as possible, keeping the holes in the rod pointing upward. See Figure 35.

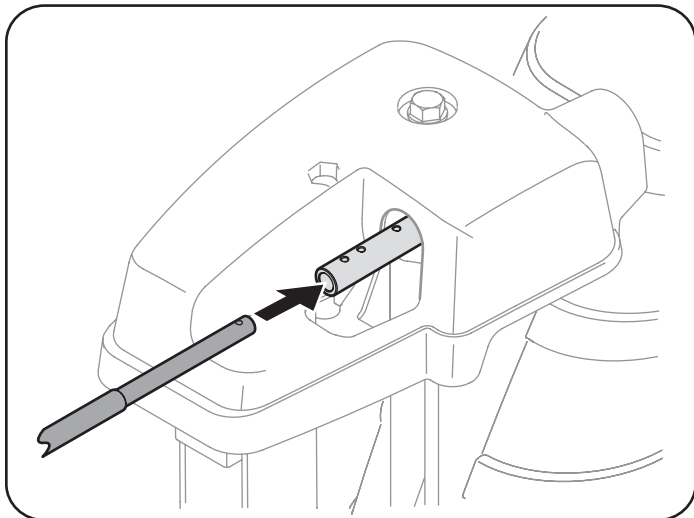

Figure 35

3. Place chute onto chute base and ensure chute control rod is positioned under handle panel. Secure chute control head to chute support bracket with clevis pin and bow-tie cotter pin removed in Step 1. See Figure 36.

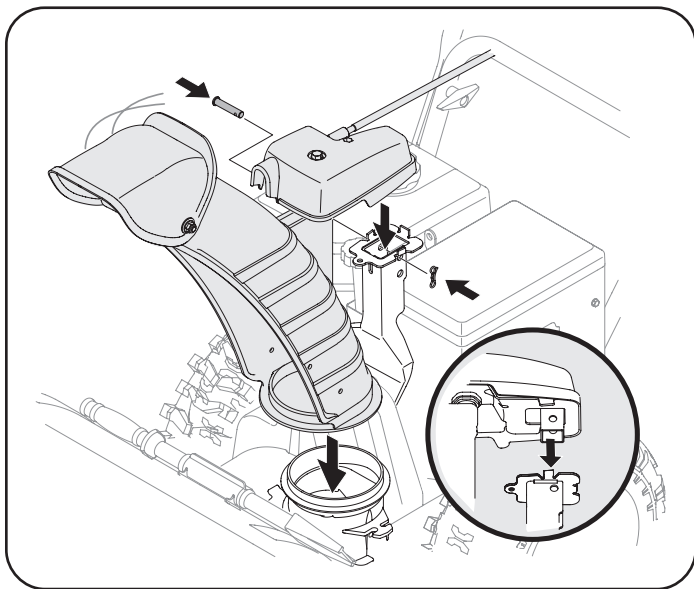

Figure 36

4. Finish securing chute control head by installing hex screw and wing nut removed in Step 2. See Figure 37.

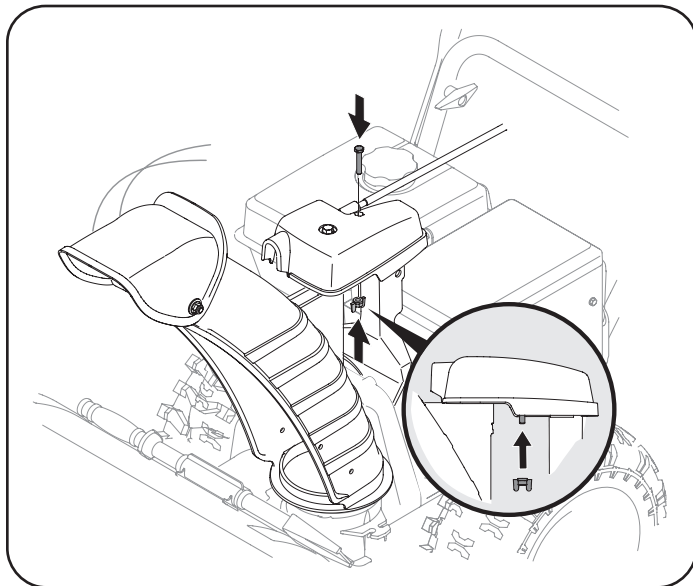

Figure 37

5. Insert the other end of the chute control rod into the input shaft below the handle panel. Make sure to line up the flat end of the rod and the flat end of the input shaft. You may need to rotate the rod around until these two surfaces line up. See Figure 38.

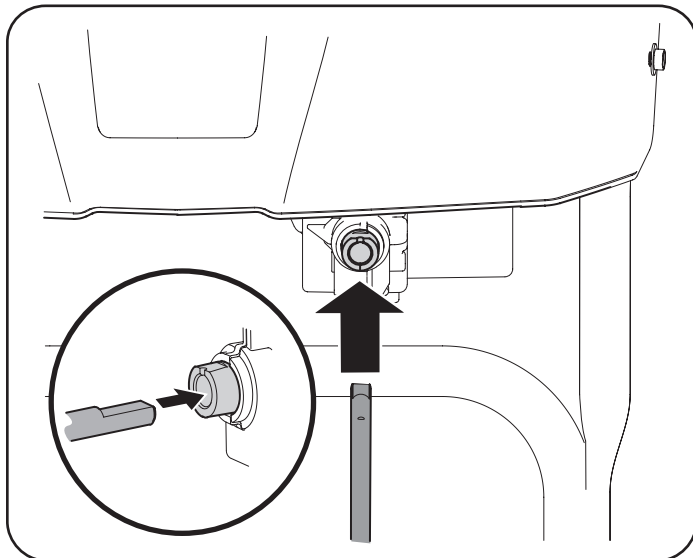

Figure 38

ASSEMBLY

6. Push the chute control rod toward the control panel until the hole in the rod lines up with the middle hole in the chute control input and insert the cotter pin removed in Step 1. See Figure 39.

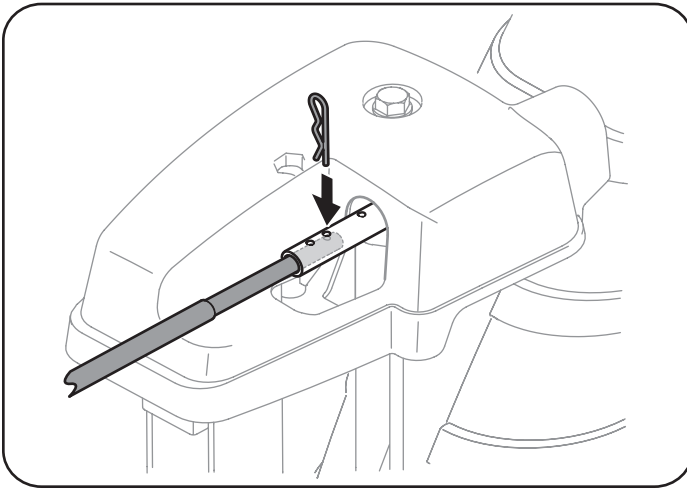

Figure 39

NOTE: There is a reference hole provided at rear end of control rod to help know when holes are vertical.

NOTE: The hole furthest from the chute control head is used to achieve further engagement of the chute control rod into the input shaft if required. Refer to Page 33 of the Maintenance & Adjustments section for Chute Control Rod adjustment.



Continue to Set-Up (page 18).

Set-Up

Chute Control Cable Routing (If Equipped)

For units equipped with 2-way or 4-way chute control joystick, electric chute control and/or chute-pitch controls, ensure control cables are routed properly.

NOTE: For smoothest operation, cables should all be to the left of the chute directional control rod.

NOTE: The number of cables routed through the wire guides will depend on unit model.

1. Locate cable guide on top of engine and ensure cable(s) are properly routed through the cable guide. See Figure 40.

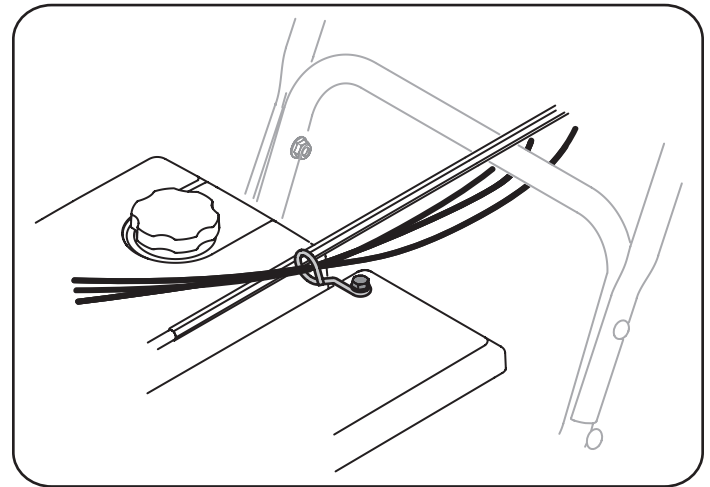

Figure 40

Shear Pins

Holes are located in the plastic dash panel for convenient shear pin storage. See Figure 41. Refer to page 16 in the Operation section for more information regarding shear pin replacement.

NOTE: If the extra shear pins are not already assembled in the handle panel, they can be found in the manual bag.

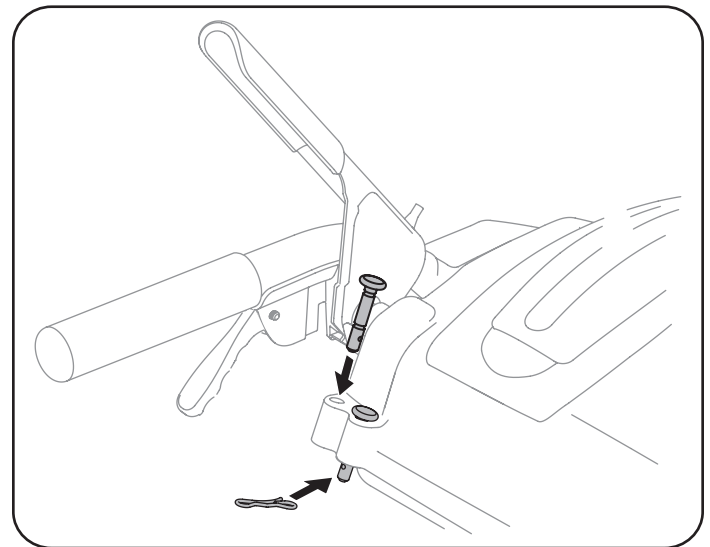

Figure 41

ASSEMBLY

Chute Clean-Out Tool

A chute clean-out tool is fastened to the top of the auger housing with a mounting clip. See Figure 42. The tool is designed to clear a chute assembly of ice and snow. This item is fastened with a cable tie at the factory. Cut the cable tie before operating the snow blower.

WARNING

Never use your hands to clear a clogged chute assembly. Shut OFF engine and remain behind handles until all moving parts have stopped before using the clean-out tool to clear the chute assembly.

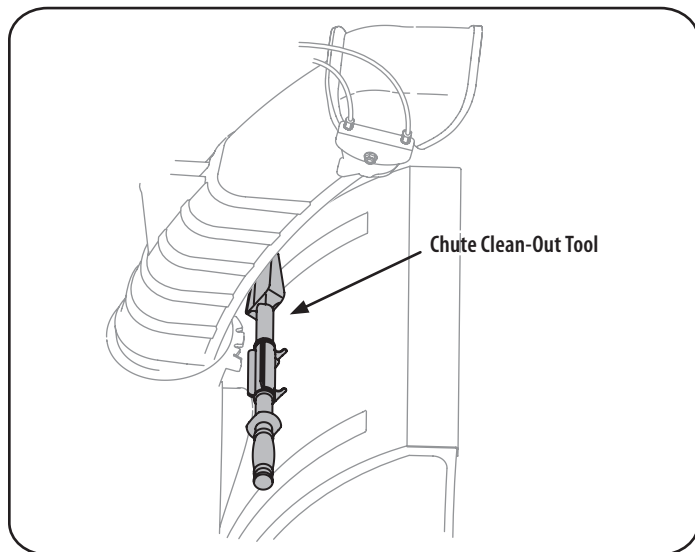

Figure 42

Drift Cutters (if equipped)

1. Remove the two screws and wing knobs that secure each drift cutter, and remove them from the sides of the auger housing.
2. Turn the drift cutters around and position them as shown in Figure 43 to the outside of the auger housing.

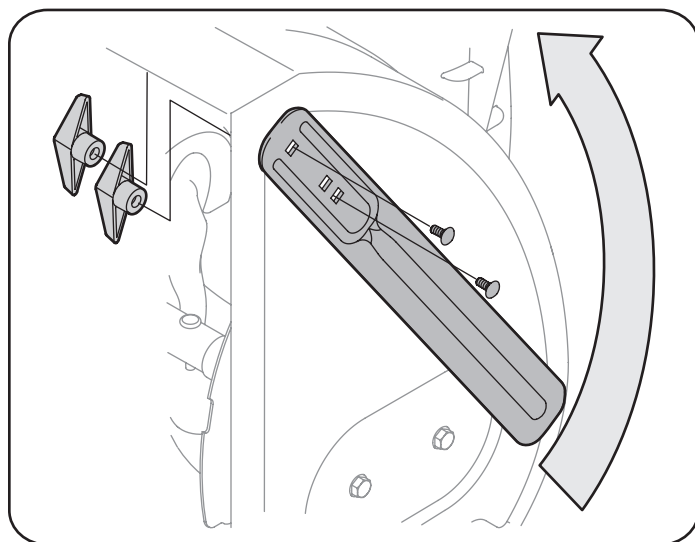

Figure 43

3. Attach the drift cutters with the screws and wing knobs on the outside of the auger housing as shown in Figure 44.

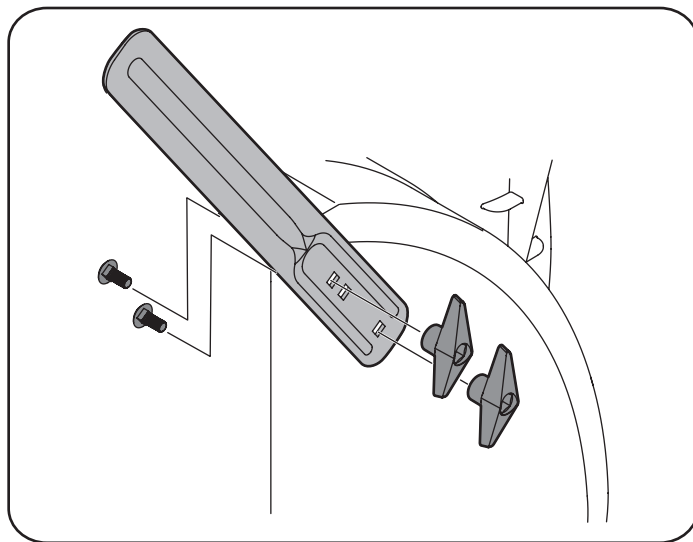

Figure 44

Tire Pressure (If Applicable)

WARNING

Under any circumstance do not exceed manufacturer's recommended psi. Equal tire pressure should be maintained at all times. Excessive pressure when seating beads may cause tire/rim assembly to burst with force sufficient to cause serious injury. Refer to sidewall of tire for recommended pressure.

The tires are over-inflated for shipping purposes. Check the tire pressure before operating the snow blower. Refer to the tire side wall for tire manufacturer's recommended psi and deflate (or inflate) the tires as necessary.

NOTE: Equal tire pressure is to be maintained at all times for performance purposes.

Adjustments

Skid Shoes

The snow blower skid shoes are adjusted at the factory to be approx 1/8" below the bottom surface of the shave plate. Adjust them downward, if desired, prior to operating the snow blower.

CAUTION

It is not recommended that you operate this snow blower on gravel as it can easily pick up and throw loose gravel, causing personal injury or damage to the snow blower and surrounding property.

- For close snow removal on a smooth surface, raise skid shoes higher on the auger housing. Refer to Figure 45.
- Use a middle or lower position when the area to be cleared is uneven, such as a gravel driveway.

NOTE: If you choose to operate the snow blower on a gravel surface, keep the skid shoes in position for maximum clearance between the ground and the shave plate.

ASSEMBLY

To adjust the skid shoes:

1. Loosen the four hex nuts (two on each side), flat washers, and carriage bolts. Move skid shoes to desired position. See Figure 45.
2. Make certain the entire bottom surface of skid shoe is against the ground to avoid uneven wear on the skid shoes.
3. Retighten nuts, washers, and bolts securely.

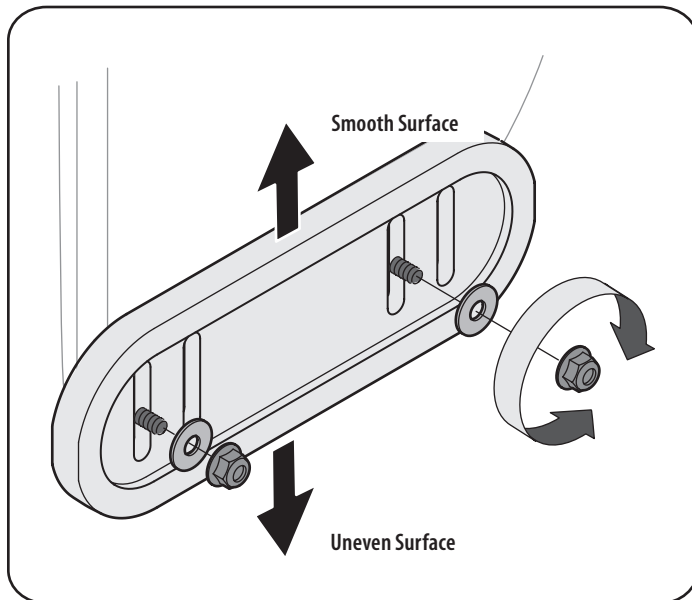

Figure 45

NOTE: The skid shoes on your unit may look slightly different (and have different hardware) than ones shown in Figure 45.

Auger Control

WARNING

Prior to operating your snow blower, carefully read and follow all instructions below. Perform all adjustments to verify your snow blower is operating safely and properly.

Check the adjustment of the auger control as follows:

1. The auger control is located on the left handle. See Figure 46 inset. When the auger control is released and in the disengaged "UP" position, the cable should have very little slack. It should NOT be tight.
2. In a well-ventilated area, start the snow blower engine as instructed in Starting Engine on page 25-26 in the Operation section of this manual.
3. While standing in the operator's position (behind the snow blower), engage the auger.
4. Allow the auger to remain engaged for approximately ten seconds before releasing the auger control. Repeat this several times.
5. With the auger control in the disengaged "UP" position, walk to the front of the machine.

6. Confirm that the auger has completely stopped rotating and shows NO signs of motion. If the auger shows ANY signs of rotating, immediately return to the operator's position and shut OFF the engine. Wait for ALL moving parts to stop before adjusting the auger control.

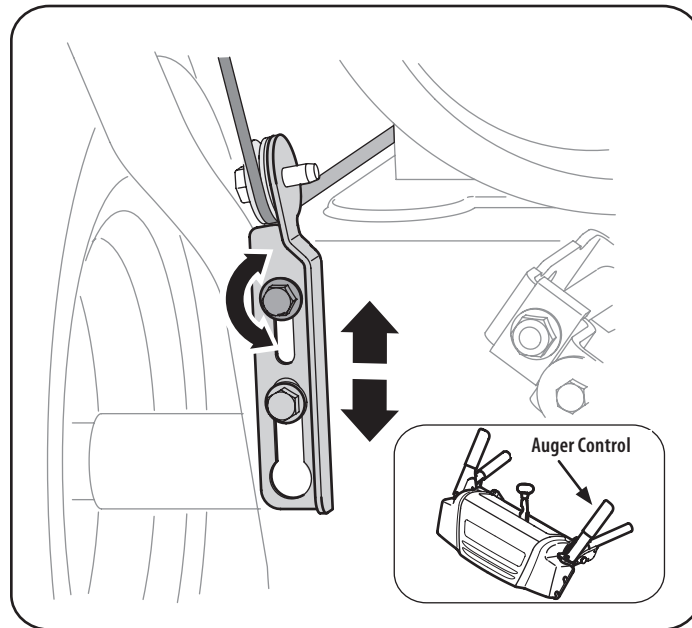

Figure 46

7. To readjust the control cable, loosen the upper hex bolt on the auger cable bracket. See Figure 46.
8. Position the bracket upward to provide more slack (or downward to increase cable tension).
9. Retighten the upper hex bolt.
10. Repeat Step 2 through Step 6 above to verify proper adjustment has been achieved.

OPERATION

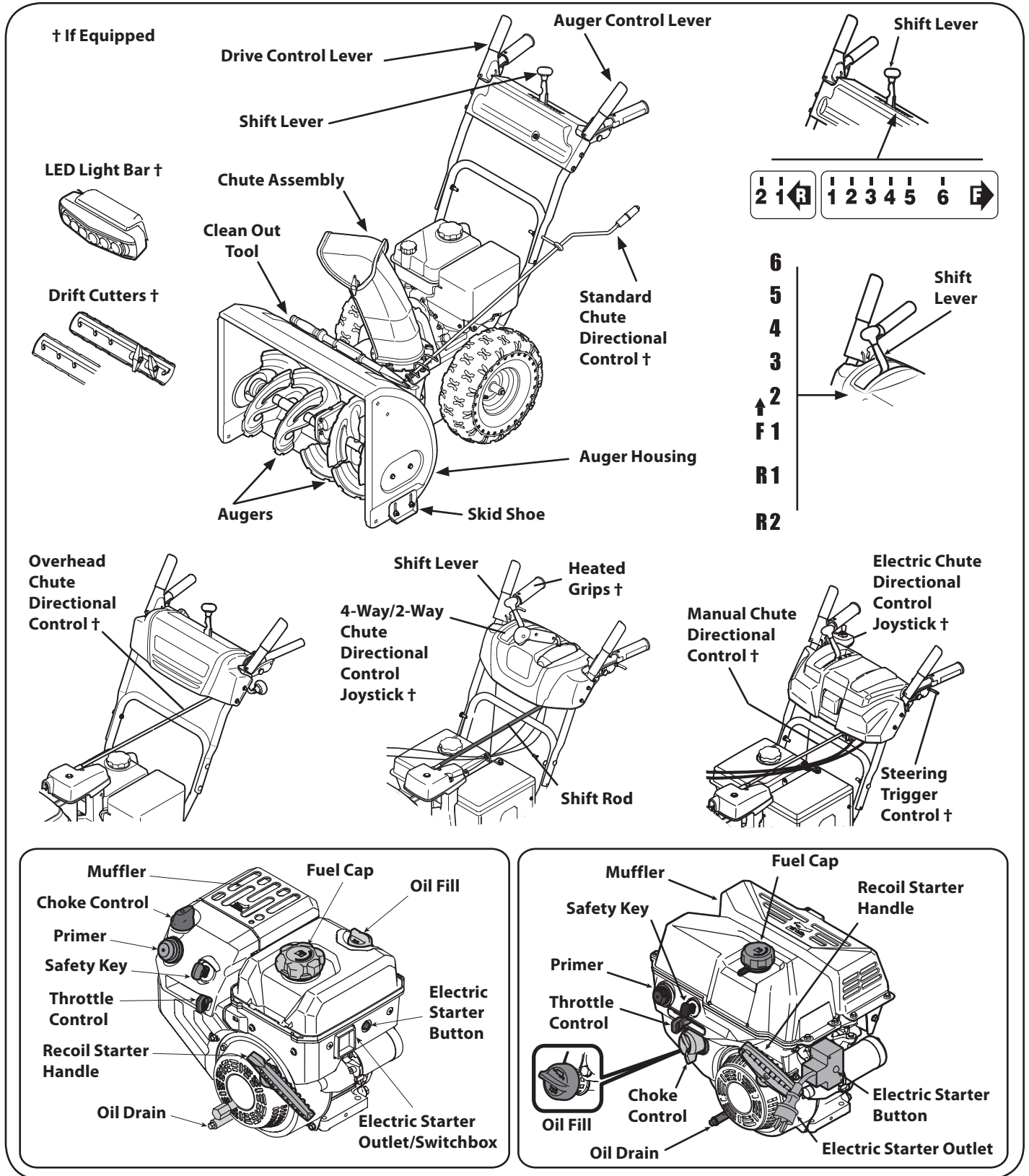

Figure 38

Meets ANSI Safety Standards

Craftsman Snow Blowers conform to the safety standard of the American National Standards Institute (ANSI).

OPERATION

Now that you have set up your snow blower, it's important to become acquainted with its controls and features. Refer to Figure 38.

NOTE: This Operator's Manual covers several models. Snow blower features may vary by model. Not all features in this manual are applicable to all snow blower models and the snow blower depicted may differ from yours.

NOTE: All references to the left or right side of the snow blower are from the operator's position. Any exceptions will be noted.

Shift Lever

The shift lever is located on the right side of the handle panel. Place the shift lever into any of eight positions to control the direction of travel and ground speed.

Forward

Your snow blower has six forward (F) speeds. Position one (1) is the slowest and position six (6) is the fastest.

Reverse

Your snow blower has two reverse (R) speeds. Position one (1) is the slower and position two (2) is the faster.

Drift Cutters (If Equipped)

The drift cutters are designed for use in deep snow. Their use is optional for normal snow conditions. Maneuver the snow blower so that the cutters penetrate a high standing snow drift to assist snow falling into the augers for throwing.

Safety Key

The safety key is a safety device. It must be fully inserted in order for the engine to start. Remove the safety key when the snow blower is not in use.

NOTE: Do not turn the safety key in an attempt to start the engine. Doing so may cause it to break.



Choke Control

The choke control is found on the rear of the engine and is activated by turning the rotary choke knob to the CHOKE position. Activating the choke control closes the choke plate on the carburetor and aids in starting the engine.



Recoil Starter Handle

This handle is used to manually start the engine.

LED Light (If Equipped)

The LED light is located inside of the handle panel and is ON when the engine is running.

LED Light Bar (If Equipped)

The LED headlight is located on top of the auger housing and is automatically turned ON when the engine is started.

Throttle Control



The throttle control is located on the rear of the engine. It regulates the speed of the engine and will shut off the engine when moved into the STOP position.

Primer

Depressing the primer forces fuel directly into the engine's carburetor to aid in cold-weather starting.

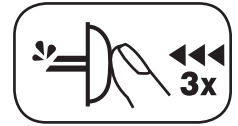

Electric Starter Button (If Equipped)

Pressing the electric starter button engages the engine's electric starter when plugged into a 120V power source.

Electric Starter Outlet (If Equipped)

Requires the use of a three-prong outdoor extension cord and a 120V power source/wall outlet.

Oil Fill

Engine oil level can be checked and oil added through the oil fill.

Fuel Cap

Unthread the fuel cap to add gasoline to the fuel tank.

Auger

When engaged, the auger blades rotate and draw snow into the auger housing.

Chute Assembly

Snow drawn into the auger housing is discharged out the chute assembly.

Skid Shoes

Position the skid shoes based on surface conditions. Adjust upward for hard-packed snow. Adjust downward when operating on gravel or crushed rock surfaces.

Wheel Steering Controls (If Equipped)

The left and right wheel steering controls are located on the underside of the handles. Squeeze the right control to turn right; squeeze the left control to turn left.

NOTE: Operate the snow blower in open areas until you are familiar with these controls.

OPERATION

Auger Control

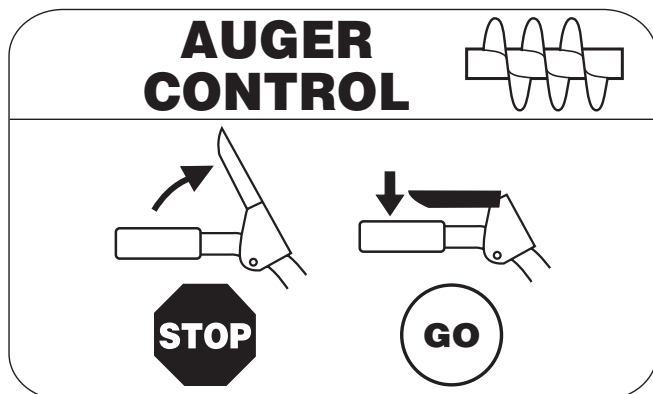

The auger control is located on the left handle. Squeeze the control grip against the handle to engage the auger and start snow throwing action. Release to stop.

IMPORTANT: Refer to the Auger Control information in the Assembly & Set-Up section prior to operating your snow blower. Read and follow all instructions carefully and perform all adjustments to verify your snow blower is operating safely and properly.

Drive Control/ Auger Control Lock*

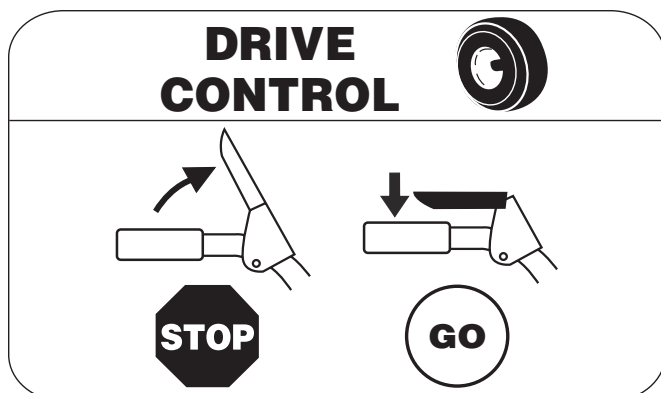

The drive control is located on the right handle. Squeeze the control grip against the handle to engage the wheel drive. Release to stop.

*On select models, the drive control also locks the auger control so you can operate the chute directional control without interrupting the snow throwing process. If the auger control is engaged simultaneously with the drive control, the operator can release the auger control (on the left handle) and the augers will remain engaged. Release both controls to stop the augers and wheel drive.

NOTE: Always release the drive control before changing speeds. Failure to do so will result in increased wear on your machine's drive system.

Overhead Chute Directional Control (If Equipped)

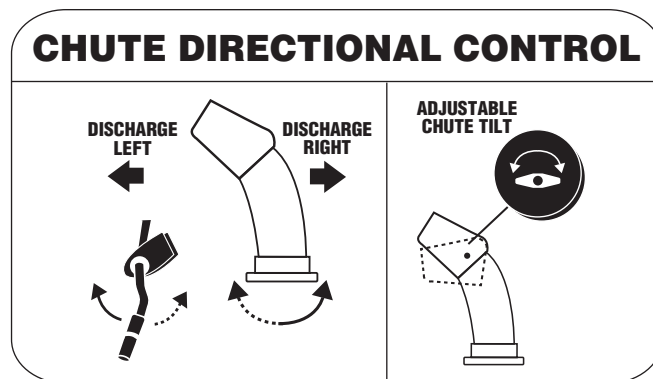

The overhead chute directional control is located in the center of the snow blower between the handle panel and lower handle. To change the direction in which snow is thrown, rotate the chute directional control.

Two-Way Chute Control (If Equipped)

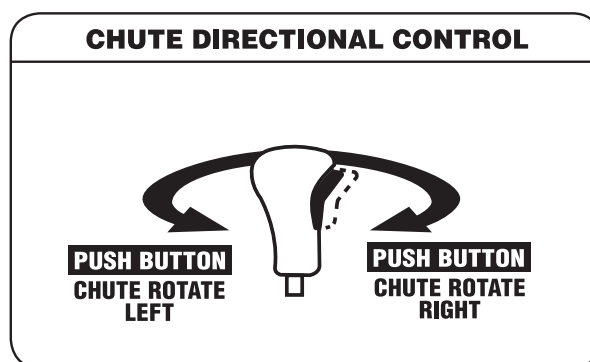

The two-way chute control (Joystick) is located on the left side of the handle panel.

- To change the direction in which snow is thrown, squeeze the button on the chute control lever and pivot the chute control lever to the right or to the left.

OPERATION

Four-Way Chute Control (Joystick) (If Equipped)

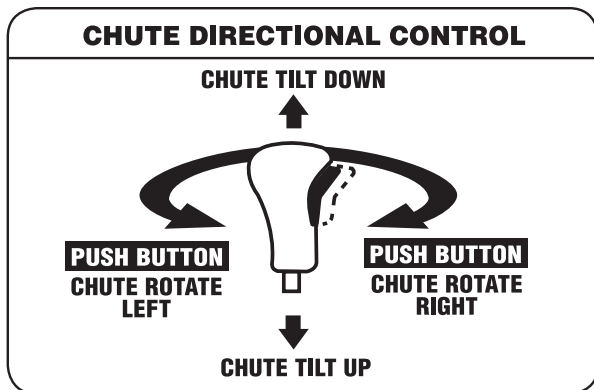

The four-way chute control™ (joystick) is located on the left side of the handle panel.

- To change the direction in which snow is thrown, squeeze the button on the chute control lever and pivot the chute control lever to the right or to the left.
- To change the angle/distance which snow is thrown, pivot the chute control lever forward to tilt the chute down and backward to tilt the chute up.

Electric Chute Control Joystick (If Equipped)

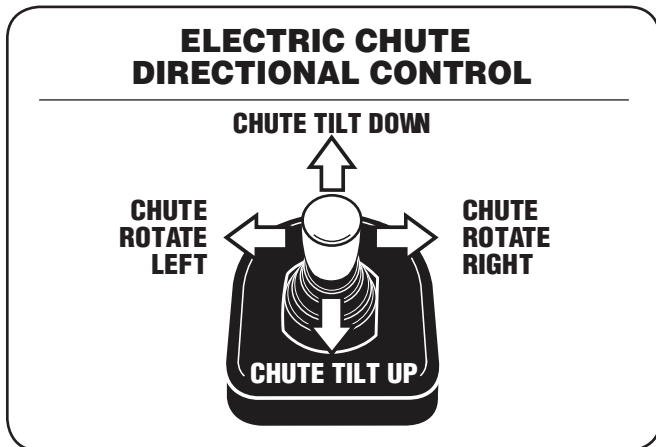

The electric chute control (joystick) is located on the right side of the handle panel.

- To change the direction in which snow is thrown, move the joystick to the right or to the left.
- To change the angle/distance which snow is thrown, pivot the joystick forward to tilt the chute down and backward to tilt the chute up.

Clean-Out Tool

WARNING

Never use your hands to clear a clogged chute assembly. Shut off engine and remain behind handles until all moving parts have stopped before using the clean-out tool to clear the chute assembly.

The chute clean-out tool is conveniently fastened to the rear of the auger housing with a mounting clip. Should snow and ice become lodged in the chute assembly during operation, proceed as follows to safely clean the chute assembly and chute opening:

1. Release both the Auger Control and the Drive Control.
2. Stop the engine by removing the ignition key.
3. Remove the clean-out tool from the clip which secures it to the rear of the auger housing.
4. Use the shovel-shaped end of the clean-out tool to dislodge and scoop any snow and ice which has formed in and near the chute assembly.
5. Refasten the clean-out tool to the mounting clip on the rear of the auger housing, reinsert the ignition key and start the snow blower's engine.
6. While standing in the operator's position (behind the snow blower), engage the auger control for a few seconds to clear any remaining snow and ice from the chute assembly.

OPERATION

Before Starting Engine

WARNING

Read, understand, and follow all instructions and warnings on the machine and in this manual before operating.

Oil

The unit was shipped with oil in the engine. Check oil level before each operation to ensure adequate oil in the engine.

NOTE: Be sure to check the engine on a level surface with the engine stopped.

1. Remove the oil filler cap/dipstick and wipe the dipstick clean.
2. Insert the cap/dipstick into the oil filler neck, but do NOT screw it in.
3. Remove the oil filler cap/dipstick. If the level is low, slowly add oil (5W-30, with a minimum classification of SF/SG) until oil level registers between high (H) and low (L).

NOTE: Do not overfill. Overfilling with oil may result in engine smoking, hard starting or spark plug fouling.

4. Replace and tighten cap/dipstick firmly before starting engine.

Gasoline

Use automotive gasoline (unleaded or low leaded to minimize combustion chamber deposits) with a minimum of 87 octane. Gasoline with up to 10% ethanol or 15% MTBE (Methyl Tertiary Butyl Ether) can be used. Never use an oil/gasoline mixture or dirty gasoline. Avoid getting dirt, dust, or water in the fuel tank. DO NOT use E85 gasoline.

- Refuel in a well-ventilated area with the engine stopped. Do not smoke or allow flames or sparks in the area where the engine is refueled or where gasoline is stored.
- Do not overfill the fuel tank. After refueling, make sure the tank cap is closed properly and securely.
- Be careful not to spill fuel when refueling. Spilled fuel or fuel vapor may ignite. If any fuel is spilled, make sure the area is dry before starting the engine.
- Avoid repeated or prolonged contact with skin or breathing of vapor.

WARNING

Use extreme care when handling gasoline. Gasoline is extremely flammable and the vapors are explosive. Never fuel the machine indoors or while the engine is hot or running. Extinguish cigarettes, cigars, pipes and other sources of ignition.

1. Clean around fuel fill before removing cap to fuel.
2. Fill tank until fuel reaches 1/2 inch below the bottom of the filler neck to allow space for fuel expansion. Be careful not to overfill.

Starting The Engine

WARNING

Always keep hands and feet clear of moving parts. Do not use a pressurized starting fluid. Vapors are flammable.

NOTE: Allow the engine to warm up for a few minutes after starting. The engine will not develop full power until it reaches operating temperatures.

1. Make certain both the auger control and drive control are in the disengaged (released) position.
2. Insert key into slot. Make sure it snaps into place. Do not attempt to turn the key.

NOTE: The engine cannot start without the key fully inserted into the ignition switch.

OPERATION

Electric Starter

WARNING

The electric starter is equipped with a grounded three-wire power plug, and is designed to operate on 120 volt AC household current. It must be used with a properly grounded three-prong receptacle at all times to avoid the possibility of electric shock. Follow all instructions carefully prior to operating the electric starter. DO NOT use electric starter in the rain.



Determine that your home's wiring is a three-wire grounded system. Ask a licensed electrician if you are not certain.

If you have a grounded three-prong receptacle, proceed as follows. If you do not have the proper house wiring, DO NOT use the electric starter under any conditions.

1. Plug an extension cord into the outlet located on the engine's surface. Plug the other end of extension cord into a three-prong 120-volt, grounded, AC outlet in a well-ventilated area.

CAUTION



The extension cord can be any length, but **must** be rated for 15 amps at 125 volts, grounded and rated for outdoor use.

2. Move throttle control to FAST (rabbit ) position.
3. Move choke to the CHOKE  position (cold engine start). If engine is warm, place choke in RUN position.
4. Push primer three (3) times, making sure to cover vent hole in primer bulb when pushing. If engine is warm, push primer only once. Always cover vent hole when pushing. Cool weather may require priming to be repeated.
5. Push starter button to start engine. Once the engine starts, immediately release starter button. Electric starter is equipped with thermal overload protection; system will temporarily shut-down to allow starter to cool if electric starter becomes overloaded.
6. As the engine warms, slowly rotate the choke control to RUN position. If the engine falters, restart engine and run with choke at half-choke position for a short period of time, and then slowly rotate the choke into RUN position.
7. After engine is running, disconnect extension cord from electric starter. When disconnecting, always unplug the end at the wall outlet before unplugging the opposite end from the engine.

Recoil Starter

CAUTION

Do not pull the starter handle while the engine running.

1. Move throttle control to FAST (rabbit ) position.
2. Move choke to the CHOKE  position (cold engine start). If engine is warm, place choke in RUN position.
3. Push primer three (3) times, making sure to cover vent hole when pushing. If engine is warm, push primer only once. Always cover vent hole when pushing. Cool weather may require priming to be repeated.

4. Pull gently on the starter handle until it begins to resist, then pull quickly and forcefully to overcome the compression. Do not release the handle and allow it to snap back. Return rope SLOWLY to original position. If required, repeat this step.

WARNING

Keep a firm grip on the starter cord handle to prevent rapid retraction of starter cord (kickback). Rapid retraction can pull hand and arm toward engine faster than you can let go, and result in broken bones, fractures, bruises or sprains.

5. As the engine warms, slowly rotate the choke control to RUN position. If the engine falters, restart engine and run with choke at half-choke position for a short period of time, and then slowly rotate the choke into RUN position.

WARNING

To avoid unsupervised engine operation, never leave the machine unattended with the engine running. Turn the engine off after use and remove key.

Stopping The Engine

After you have finished snow-throwing, run engine for a few minutes before stopping to help dry off any moisture on the engine.

1. Move throttle control to OFF position.
2. Remove the key. Removing the key will reduce the possibility of unauthorized starting of the engine while equipment is not in use. Keep the key in a safe place. The engine cannot start without the key.
3. Wipe any moisture away from the controls on the engine.

To Engage Drive

1. With the throttle control in the Fast (rabbit ) position, move shift lever into one of the six forward (F) positions or two reverse (R) positions. Select a speed appropriate for the snow conditions and a pace you're comfortable with.

NOTE: When selecting a Drive Speed, use the slower speeds until you are comfortable and familiar with the operation of the snow blower.

2. Squeeze the drive control against the handle and the snow blower will move. Release it and drive motion will stop.

NOTE: NEVER reposition the shift lever (change speeds or direction of travel) without first releasing the drive control and bringing the snow blower to a complete stop. Doing so will result in premature wear to the snow blower's drive system.

To Engage Auger

1. To engage the auger and start throwing snow, squeeze the auger control against the left handle. Release to stop the auger.

OPERATION

Replacing Shear Pins

WARNING

NEVER replace the auger shear pins with anything other than OEM Part No. 738-04124A (gold colored replacement shear pins) or OEM Part No. 738-05273 (Black colored replacement shear pins). Any damage to the auger gearbox or other components as a result of failing to do so will NOT be covered by your snow blower's warranty.

WARNING

Always turn off the snow blower's engine and remove the key prior to replacing shear pins.

Each auger blade is secured to the spiral shaft with a shear pin and bow-tie clip. If an auger blade strikes a foreign object or ice jam, the pin will shear off to prevent damage to the blade. If an auger blade does not turn, check to see if its pin has sheared off.

IMPORTANT: ALWAYS use the correct OEM replacement shear pin.

2-Stage Snow Blowers

- The auger is secured to the spiral shaft using gold colored shear pins (OEM Part No. 738-04124A). See Figure 39.

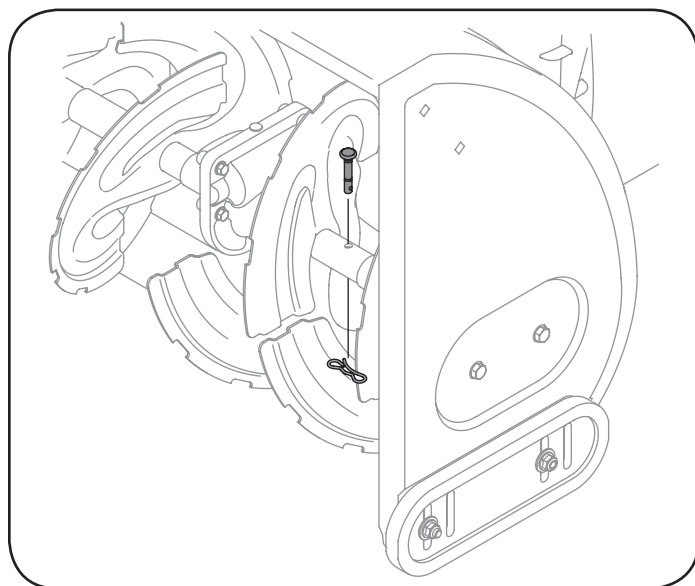

Figure 39

3-Stage Snow Blowers

- The side augers and central accelerator auger are secured to the spiral shaft using black shear pins (OEM Part No. 738-05273). See Figure 40.

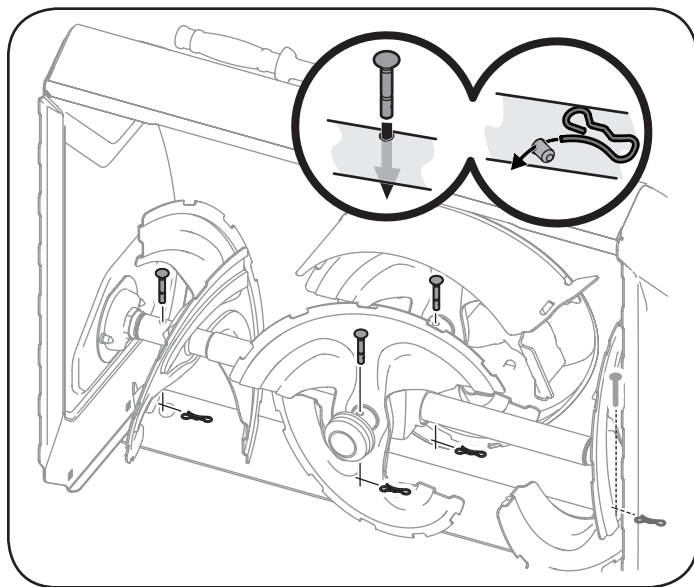

Figure 40

Using Snow Blower to Clear Snow

WARNING

Check the area to be cleared for foreign objects. Remove foreign objects, if any.

1. Start the engine following starting instructions.
2. Allow the engine to warm up for a few minutes as the engine will not develop full power until it reaches operating temperature.
3. Rotate the chute assembly to the desired direction, away from bystanders and/or buildings.
4. Making certain no bystanders or obstacles are in front of the unit, squeeze the auger control completely against the upper handle to fully engage the auger.
5. While the auger control is engaged, squeeze the drive control completely against the upper handle to engage the wheels. Do not "feather" the drive control.
6. As the snow blower starts to move, maintain a firm hold on the handle, and guide the snow blower along the path to be cleared.
7. Release the auger and drive controls to stop the snow throwing action and forward motion.
NOTE: Your unit is equipped with a clutch in the transmission. If the wheels stop turning while trying to discharge large volumes of snow, immediately disengage the drive control and allow the rotating auger to discharge snow from the housing. Reduce the clearing width and continue operation.
8. On each succeeding pass, readjust the chute assembly to the desired position and slightly overlap the previously cleared path.

SERVICE AND MAINTENANCE

MAINTENANCE SCHEDULE

⚠ WARNING

Before performing any type of maintenance/service, disengage all controls and stop the engine. Wait until all moving parts have come to a complete stop. Disconnect spark plug wire and ground it against the engine to prevent unintended starting.

Follow the maintenance schedule given below. This chart describes service guidelines only. Use the Service Log column to keep track of completed maintenance tasks. To locate the nearest Sears Service Center or to schedule service, call the following toll free number: 1-888-331-4569.

Interval	Item	Service	Service Log
Each Use and every 5 hours	<ol style="list-style-type: none"> 1. Engine oil level 2. Loose or missing hardware 3. Unit and engine. 	<ol style="list-style-type: none"> 1. Check 2. Tighten or replace 3. Clean 	
1st 5 hours	<ol style="list-style-type: none"> 1. Engine oil 	<ol style="list-style-type: none"> 1. Change 	
Annually or 25 hours	<ol style="list-style-type: none"> 1. Spark plug 2. Control linkages and pivots 3. Wheels 4. Gear shaft and Auger shaft 5. 4-Way Chute Control 	<ol style="list-style-type: none"> 1. Check 2. Lube with light oil 3. Lube with multipurpose auto grease 4. Lube with light oil 5. Check for cable slackness 	
Annually or 50 hours	<ol style="list-style-type: none"> 1. Engine oil 	<ol style="list-style-type: none"> 1. Change 	
Annually or 100 hours	<ol style="list-style-type: none"> 1. Spark plug 	<ol style="list-style-type: none"> 1. Change 	
Before Storage	<ol style="list-style-type: none"> 1. Fuel system 	<ol style="list-style-type: none"> 1. Run engine until it stops from lack of fuel 	

Engine Maintenance

Checking Engine Oil

⚠ WARNING

Before lubricating, repairing, or inspecting, disengage all controls and stop engine. Wait until all moving parts have come to a complete stop.

NOTE: Check the oil level before each use to be sure correct oil level is maintained.

NOTE: 208cc and 243cc engines use 600 ml (approx. 20 oz.).

NOTE: 277cc, 357 and 420cc engines use 1100 ml (approx. 37.2 oz).

When adding oil to the engine, refer to viscosity chart below. Do not over-fill. Use a 4-stroke, or an equivalent high detergent, premium quality motor oil certified to meet or exceed U.S. automobile manufacturer's requirements for service classification SG, SF. Motor oils classified SG, SF will show this designation on the container.

1. Remove the oil filler cap/dipstick and wipe the dipstick clean.
2. Insert the cap/dipstick into the oil filler neck, but do NOT screw it in.
3. Remove the oil filler cap/dipstick. If level is low, slowly add oil until oil level registers between high (H) and low (L). See Figure 52 or Figure 53.
4. Replace and tighten cap/dipstick firmly before starting engine.

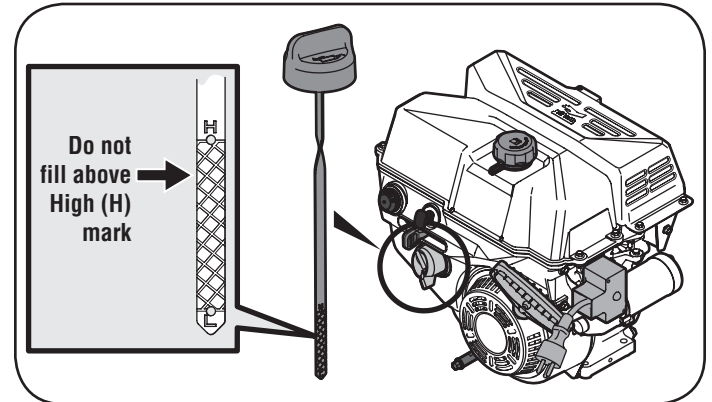

Figure 52

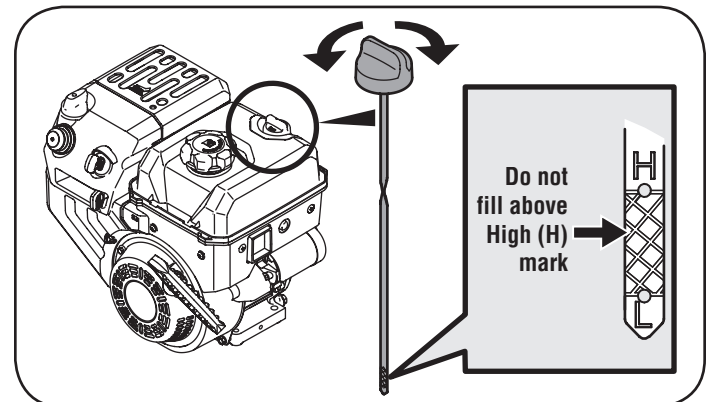

Figure 53

SERVICE AND MAINTENANCE

Changing Engine Oil

NOTE: Change the engine oil after the first 5 hours of operation and once a season or every 50 hours thereafter.

1. Drain fuel from tank by running engine until the fuel tank is empty. Be sure fuel fill cap is secure.
2. Place suitable oil collection container under oil drain plug.
3. Remove oil drain plug and washer (if equipped). See Figure 54.
4. Tip unit to drain oil into the container. Used oil must be disposed of at a proper collection center.

CAUTION

Used oil is a hazardous waste product. Dispose of used oil properly. Do not discard with household waste. Check with your local authorities or Sears Service Center for safe disposal/recycling facilities.

5. Reinstall the drain plug and washer (if equipped) and tighten it securely.
6. Refill with the recommended oil and check the oil level. See Recommended Oil Usage chart.

NOTE: 208cc and 243cc engines use 600 ml (approx. 20 oz.).

NOTE: 277cc, 357 and 420cc engines use 1100 ml (approx. 37.2 oz.).

	← Synthetic 0W-30 →				
	← 5W-30 →				
(°F)	-40°	-20°	0°	20°	40°
(°C)	-30°	-20°	-10°	0°	

CAUTION

DO NOT use nondetergent oil or 2-stroke engine oil. It could shorten the engine's service life.

7. Reinstall the oil filler cap/dipstick securely.

CAUTION

Thoroughly wash your hands with soap and water as soon as possible after handling used oil.

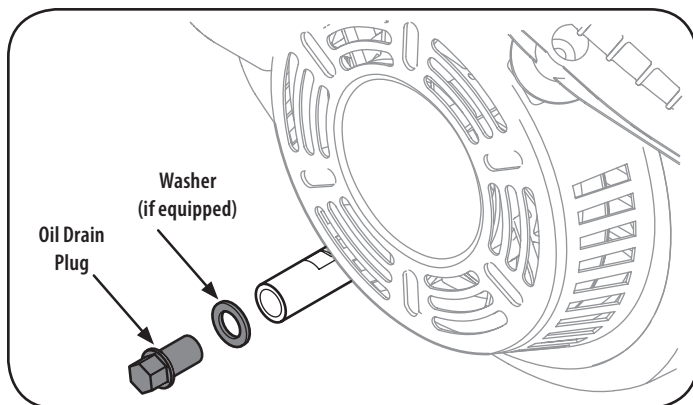

Figure 54

Checking Spark Plug

WARNING

DO NOT check for spark with spark plug removed. DO NOT crank engine with spark plug removed.

WARNING

If the engine has been running, the muffler will be very hot. Be careful not to touch the muffler.

NOTE: Check the spark plug once a season or every 25 hours of operation. Change the spark plug once a season or every 100 hours. To ensure proper engine operation, the spark plug must be properly gapped and free of deposits.

1. Remove the spark plug boot and use a spark plug wrench to remove the plug. See Figure 55.
2. Visually inspect the spark plug. Discard the spark plug if there is apparent wear, or if the insulator is cracked or chipped. Clean the spark plug with a wire brush if it is to be reused.
3. Measure the plug gap with a feeler gauge. Correct as necessary by bending side electrode. See Figure 56. The gap should be set to .02-.03 inches (0.60-0.80 mm).
4. Check that the spark plug washer is in good condition and thread the spark plug in by hand to prevent cross-threading.
5. After the spark plug is seated, tighten with a spark plug wrench to compress the washer.

NOTE: When installing a new spark plug, tighten 1/2-turn after the spark plug seats to compress the washer. When reinstalling a used spark plug, tighten 1/8- to 1/4-turn after the spark plug seats to compress the washer.

CAUTION

The spark plug must be tightened securely. A loose spark plug can become very hot and can damage the engine.

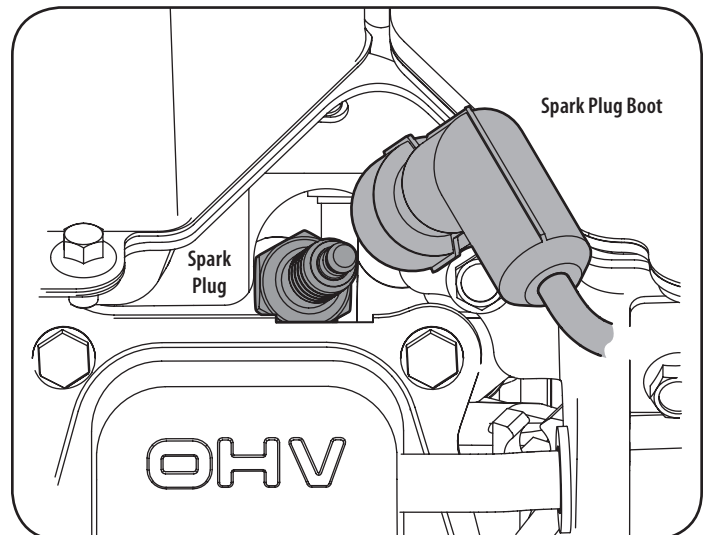

Figure 55

SERVICE AND MAINTENANCE

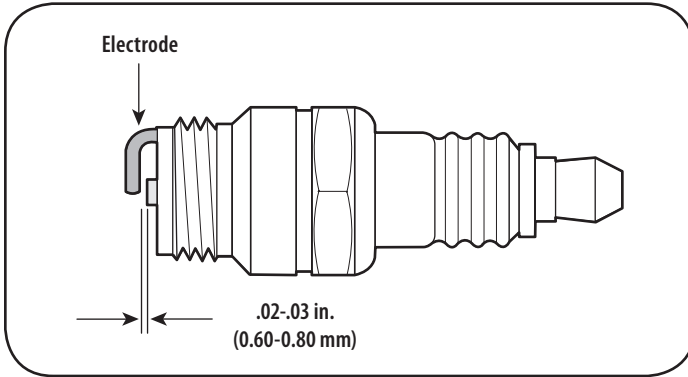

Figure 56

Lubrication

Gear Shaft

The gear (hex) shaft should be lubricated at least once a season or after every 25 hours of operation.

1. To prevent spillage, remove all fuel from tank by running engine until it stops.
2. Carefully pivot the snow blower up and forward so that it rests on the auger housing.
3. Remove the lower frame cover from the underside of the snow blower by removing the self-tapping screws which secure it.
4. Apply a light coating of anti-seize to the hex shaft. See Figure 57.

NOTE: When lubricating the hex shaft, be careful not to get any oil on the aluminum drive plate or rubber friction wheel. Doing so will hinder the snow blower's drive system. Wipe off any excess or spilled oil.

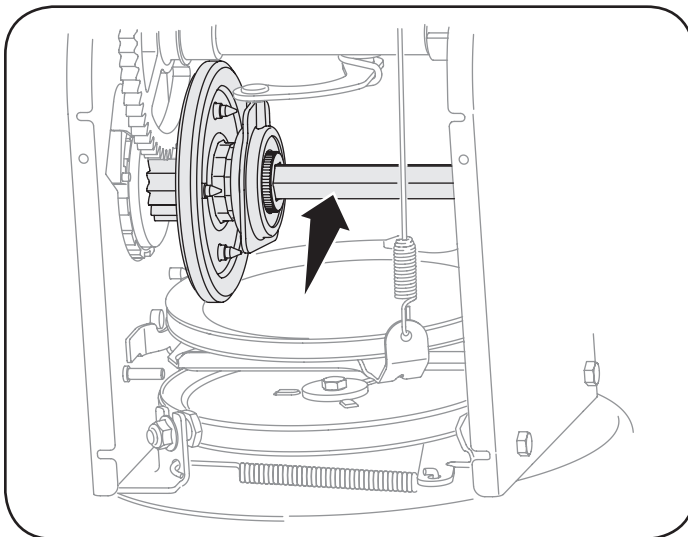

Figure 57

Wheels

At least once a season, remove both wheels. Clean and coat the axles with a multipurpose automotive grease before reinstalling wheels.

Chute Directional Control

Once a season, lubricate the eye bolt bushing and spiral with 3-in-1 oil.

Auger Shaft

At least once a season, remove the shear pins on auger shaft. Spray lubricant inside shaft, and around the spacers and flange bearings found at either end of the shaft. See Figure 58.

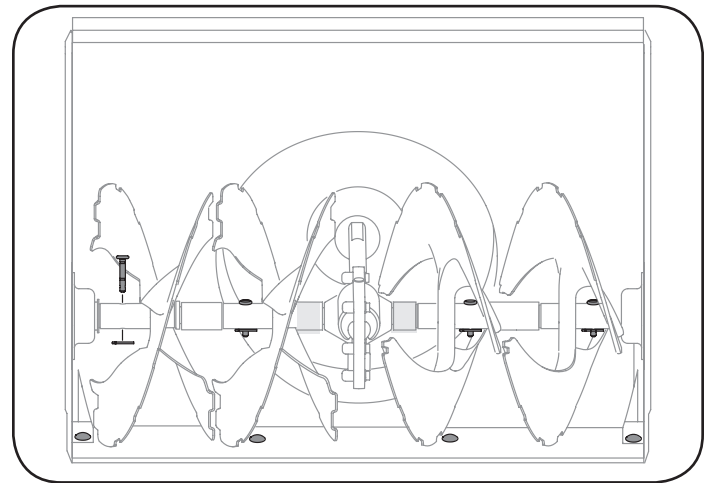

Figure 58

Shave Plate and Skid Shoes

The shave plate and skid shoes on the bottom of the snow blower are subject to wear. They should be checked periodically and replaced when necessary.

NOTE: The skid shoes on this machine have two wear edges. When one side wears out, they can be rotated 180° to use the other edge.

To remove skid shoes:

1. Remove the two carriage bolts, washers, and hex flange nuts that secure each skid shoe to the snow blower.
2. Reassemble new skid shoes with the four carriage bolts (two on each side), washers, and hex flange nuts. Refer to Figure 59.

To remove shave plate:

1. Remove the carriage bolts and hex nuts which attach it to the snow blower housing.

SERVICE AND MAINTENANCE

2. Reassemble new shave plate, making sure heads of carriage bolts are to the inside of housing. Tighten securely. See Figure 59.

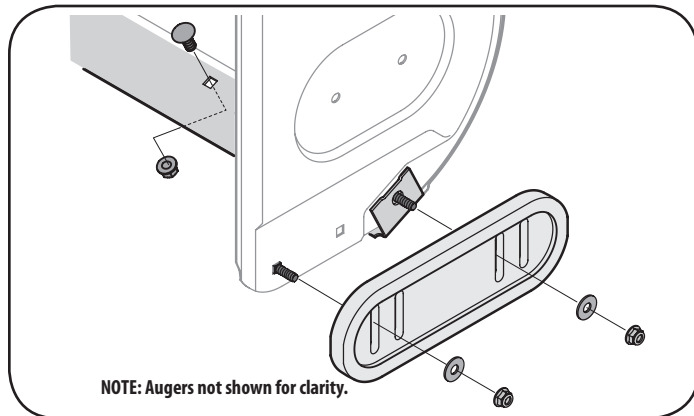

Figure 59

Adjustments

Shift Cable

If full range of speeds (forward and reverse) cannot be achieved use the mounting holes in the index bracket to adjust the shift cable tension as follows:

1. Place shift lever in fastest forward speed position (F6).
2. Lift the shift cable index bracket (a) up to create slack in the cable (b). See Figure 60.

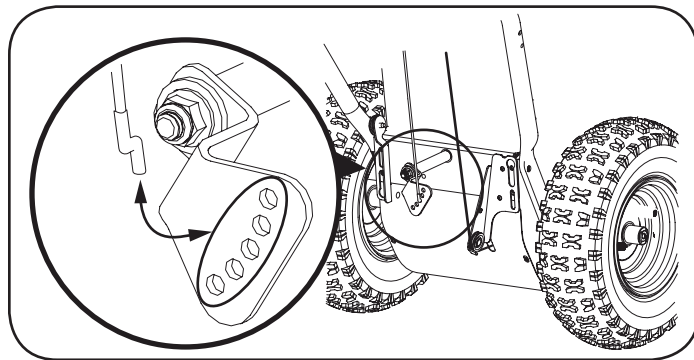

Figure 60

3. Disengage the Z fitting (c) from the index bracket.
4. Select new mounting hole and reinsert Z fitting into the index bracket. Using the upper mounting holes will loosen the shift cable. Using the lower mounting holes will tighten the shift cable.
5. Reinsert the Z fitting into the index bracket.
6. To ensure proper shift cable tension perform the following:
 - a. Start the engine and place the shift lever in the slowest forward speed. Using the drive control, ensure the unit moves forward.
 - b. Place the shift lever in the slowest reverse speed. Using the drive control, ensure the unit moves in reverse.
 - c. If necessary continue to adjust cable until the conditions in Steps a and b are satisfied.

Shift Rod

If the full range of speeds (forward and reverse) cannot be achieved, refer to the Figure 61 and adjust the shift cable as follows:

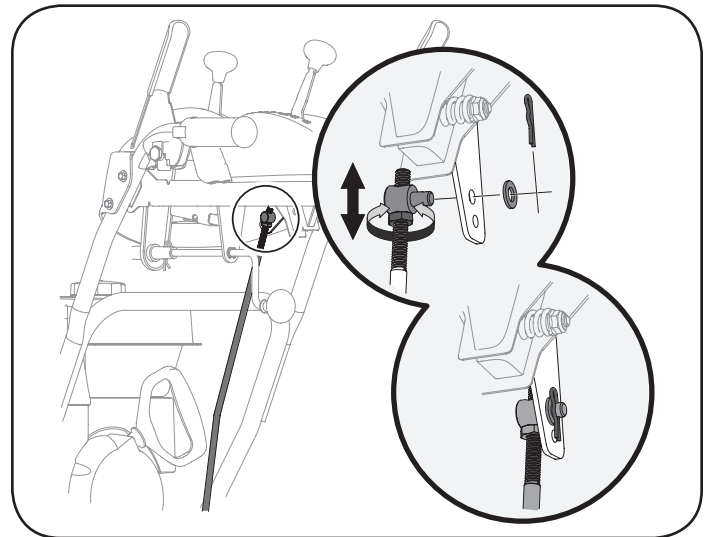

Figure 61

1. Place the shift lever in the fastest forward speed position (F6).
2. Remove cotter pin and washer from adjustment ferrule on shift rod and pull it out from shift lever. See Figure 61.
3. Pivot shift bracket downward as far as it will go. See Figure 62.

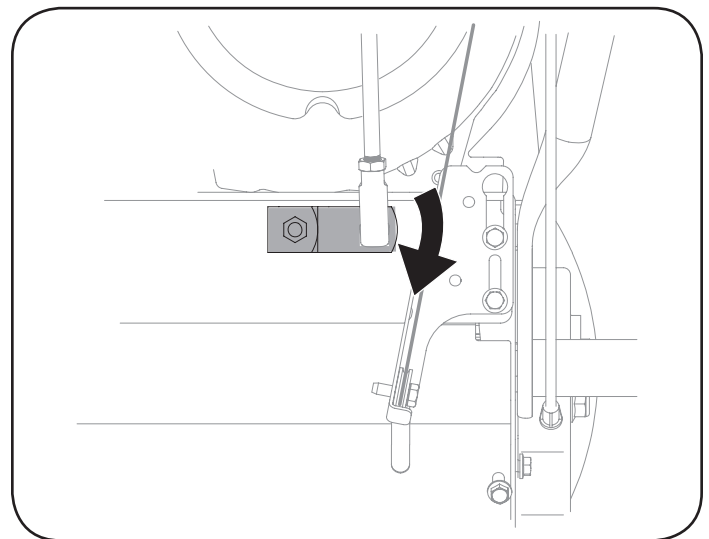

Figure 62

4. Rotate ferrule up or down on shift rod as necessary until it lines up with upper hole in shift lever. Refer to Figure 61 inset.
5. Insert the ferrule into the upper hole and secure with the washer and cotter pin.

SERVICE AND MAINTENANCE

Drive Control

When the drive control is released and in the disengaged “up” position, the cable should have very little slack. It should NOT be tight. Also, if there is excessive slack in the drive cable or if the unit experiences intermittent drive while using, the cable may need to be adjusted. Check the adjustment of the drive control as follows:

1. With the drive control released, push the snow blower gently forward. The unit should roll freely.
2. Engage the drive control and gently attempt to push the snow blower forward. The wheels should not turn. The unit should not roll freely.
3. With the drive control released, move the shift lever back and forth between the R2 position and the F6 position several times. There should be no resistance in the shift lever.
4. If any of the above tests failed, the drive cable is in need of adjustment. Proceed as follows:
 - a. Shut off the engine as instructed in the Operation section.
 - b. Loosen the lower hex bolt on the drive cable bracket. See Figure 63.
 - c. Position the bracket upward to provide more slack (or downward to increase cable tension).
 - d. Retighten the lower hex bolt.

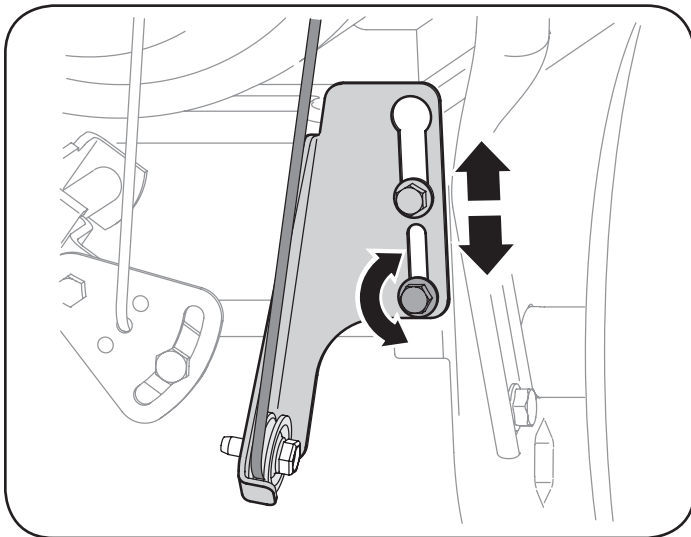

Figure 63

Chute Control Rod

To achieve more chute control rod engagement in the input shaft under the handle panel, the chute control rod will have to be adjusted. Refer to Figure 64.

To adjust this rod, proceed as follows:

1. Remove the cotter pin from the hole closest to the chute control head on the chute control input.
2. Pull out the chute control rod until the hole in it lines up with the other hole in the chute control input.
3. Reinsert the cotter pin through this hole and the chute control rod.

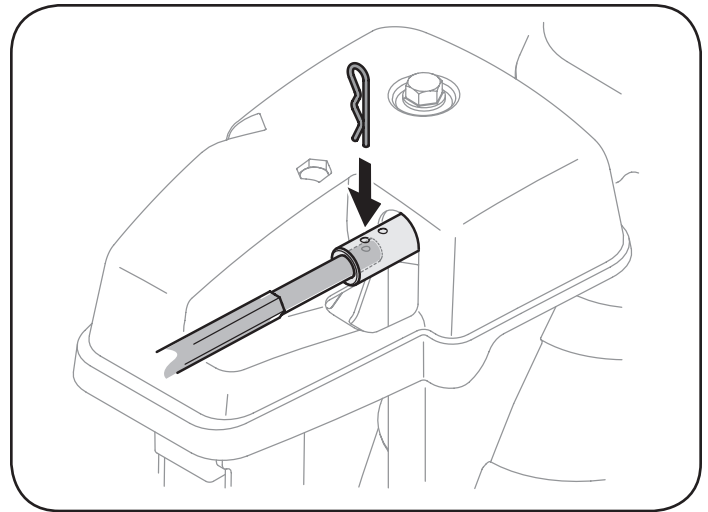

Figure 64

Chute Bracket

If the spiral at the bottom of the chute directional control is not fully engaging with the chute assembly, the chute bracket can be adjusted. To do so:

1. Loosen the two nuts which secure the chute bracket and reposition it slightly. See Figure 65.
2. Retighten the nuts.

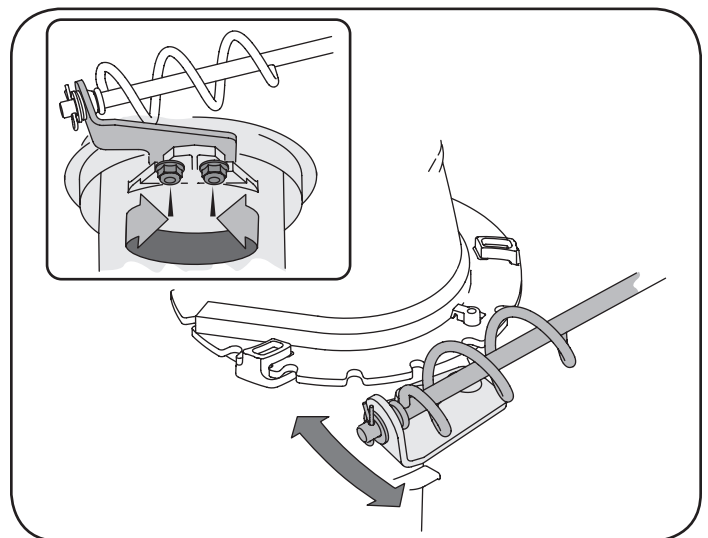

Figure 65

SERVICE AND MAINTENANCE

Chute

If the chute fails to remain stationary during operation, the pre-load of the chute can be adjusted by tightening the hex nut found on the front of the chute control head.

1. To increase the preload, tighten the hex nut clockwise in $\frac{1}{4}$ turn intervals. See Figure 66.
2. If the chute directional control is difficult to crank, decrease the preload by loosening the hex nut counterclockwise in $\frac{1}{4}$ turn intervals.

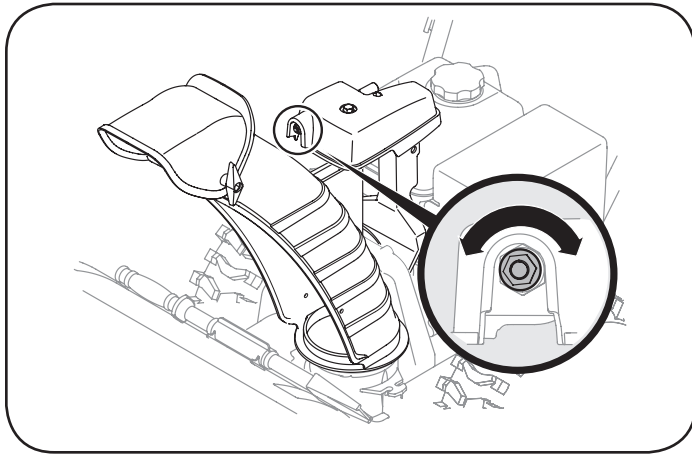

Figure 66

Auger Control

Refer to the Assembly section for instructions on adjusting the auger control cable.

Skid Shoes

Refer to the Assembly section for instructions on adjusting the skid shoes.

Belt Replacement

Auger Belt

To remove and replace your snow blower's auger belt, proceed as follows:

1. To prevent spillage, remove all fuel from tank by running engine until it stops.
2. Remove the plastic belt cover on the front of the engine by removing the two self-tapping screws. See Figure 67.

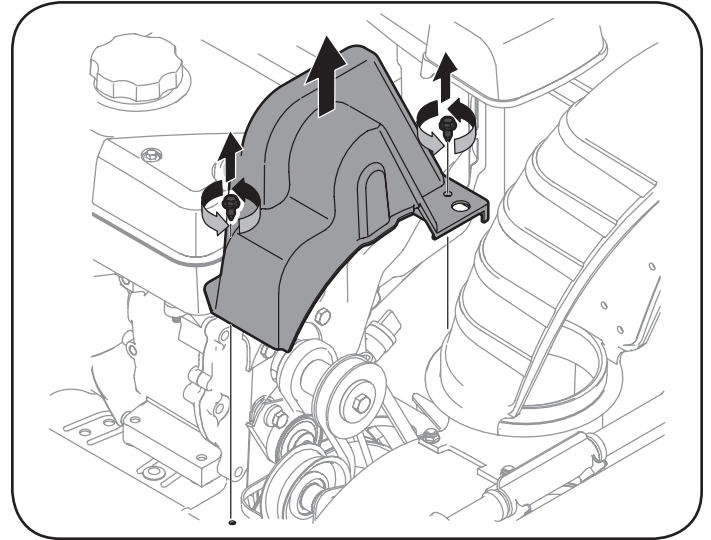

Figure 67

3. Roll the auger belt off the engine pulley. See Figure 68.

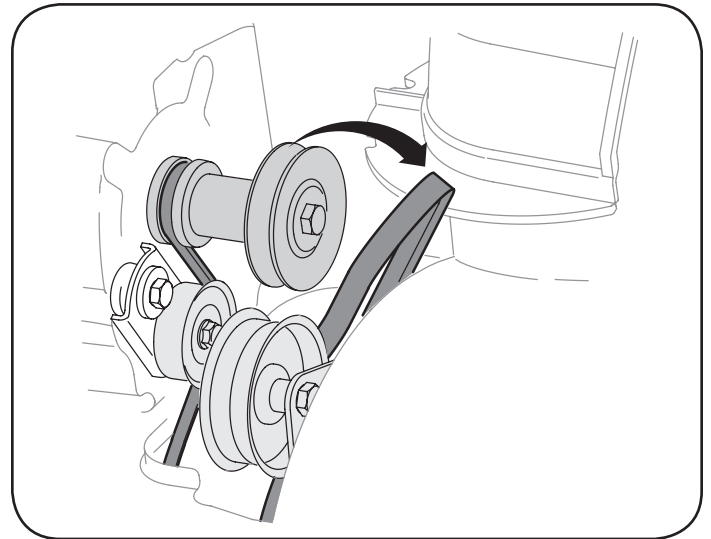

Figure 68

4. Carefully pivot the snow blower up and forward so that it rests on the auger housing.

SERVICE AND MAINTENANCE

5. Remove the frame cover from the underside of the snow blower by removing four self-tapping screws which secure it. See Figure 69.

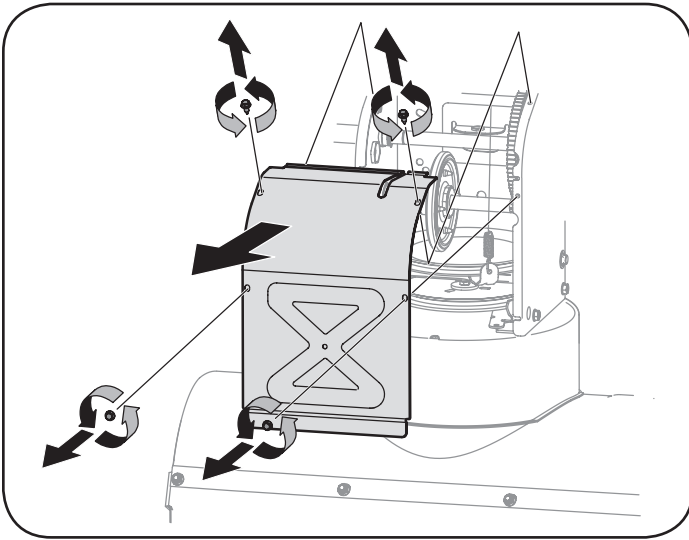

Figure 69

6. Loosen and remove the shoulder screw which acts as a belt keeper. Refer to Figure 70.

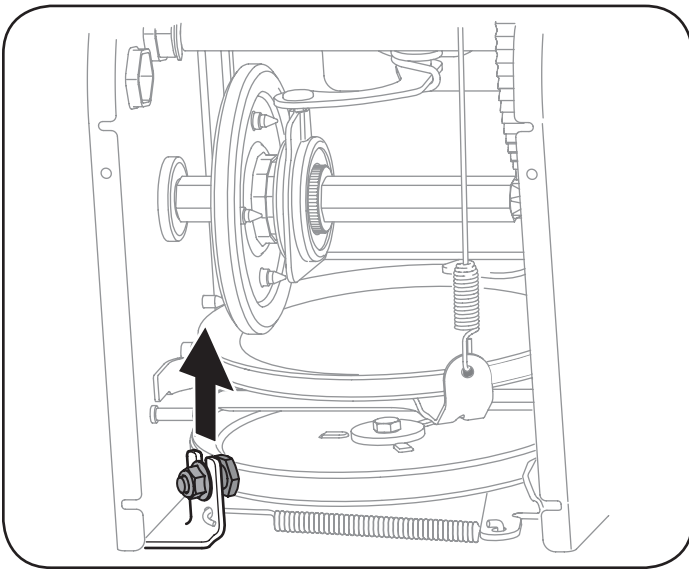

Figure 70

7. Remove the belt from around the auger pulley, and slip the belt between the support bracket and the auger pulley. See Figure 71.

NOTE: Engaging the auger control will ease removal and reinstallation of the belt.

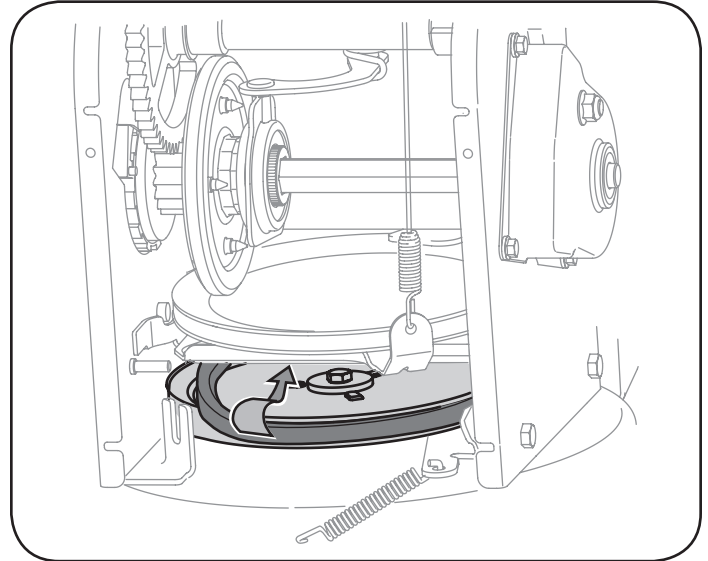

Figure 71

8. Reassemble auger belt by following instructions in reverse order.
NOTE: Do NOT forget to reinstall the shoulder screw and reconnect the spring to the frame after installing a replacement auger belt.
9. Perform the Auger Control test outlined in the Assembly section of this manual.

Drive Belt

NOTE: Several components must be removed and special tools are required in order to replace the snow blower's drive belt. Contact the nearest Sears Parts & Repair Center to have the drive belt replaced.

Friction Wheel Inspection (Steerable 500 and 800 Series & Non-Steerable Single Speed 600 Series)

If the snow blower fails to drive with the drive control engaged, and performing the drive control cable adjustment fails to correct the problem, the friction wheel may need to be replaced. Follow the instructions below. Examine the friction wheel rubber for signs of wear or cracking and replace wheel if necessary.

1. To prevent spillage, remove all fuel from tank by running engine until it stops.
2. Place the shift lever in first Forward (F1) position.
3. Carefully pivot the snow blower up and forward so that it rests on the auger housing.
4. Remove the frame cover from the underside of the snow blower by removing the self-tapping screws which secure it.

SERVICE AND MAINTENANCE

- Remove the right-hand wheel by removing the screw and bell washer which secure it to the axle. See Figure 72.

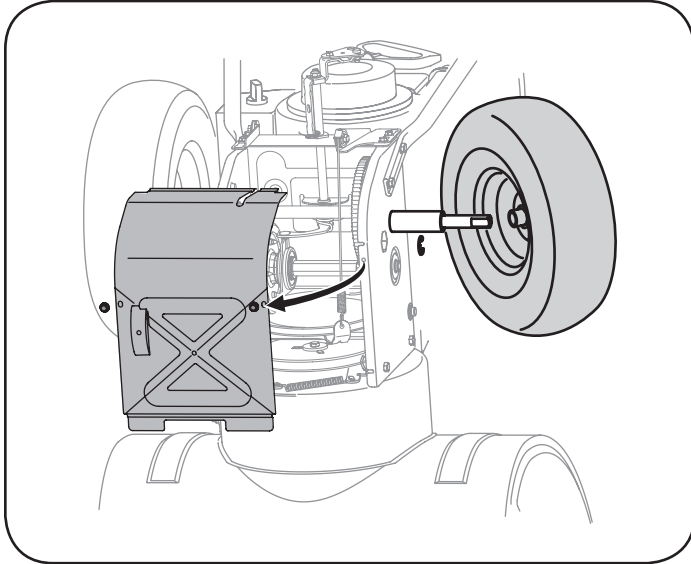

Figure 72

- Carefully remove the hex nut and washer which secures the hex shaft to the snow blower frame and lightly tap the shaft's end to dislodge the ball bearing from the right side of the frame. See Figure 73.

NOTE: Be careful not to damage the threads on the shaft.

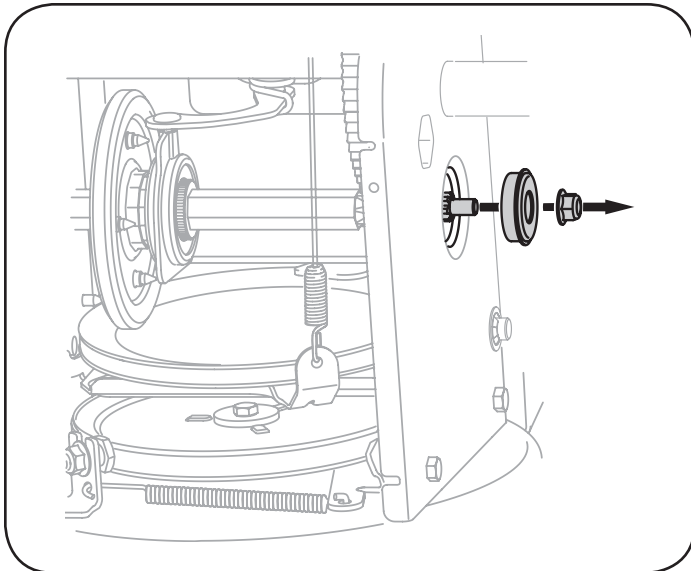

Figure 73

- Carefully position the hex shaft downward and to the left before carefully sliding the friction wheel assembly off the shaft. See Figure 74.

NOTE: If you're replacing the friction wheel assembly as a whole, discard the worn part and slide the new part onto the hex shaft.

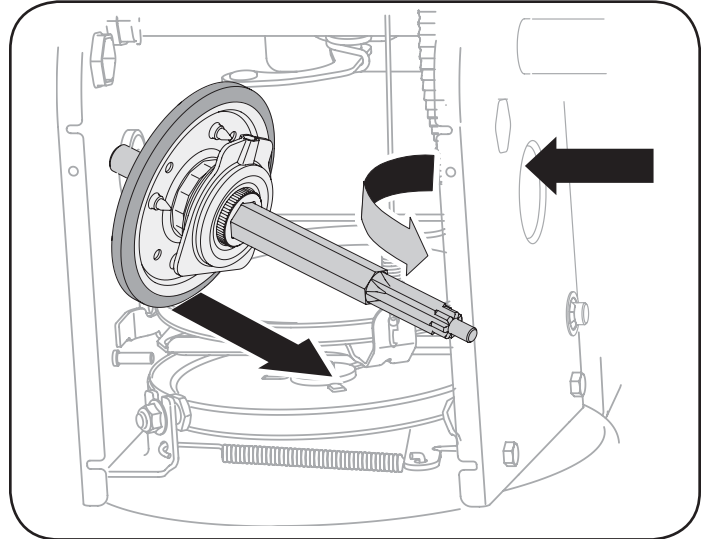

Figure 74

- Follow the steps above in reverse order to reassemble components.
- Perform the test previously described in the Drive Control section.

If you're disassembling the friction wheel and replacing only the rubber ring, proceed as follows:

NOTE: Not all friction wheels are serviceable. If this is the case, simply replace the friction wheel assembly.

- Remove the four screws which secure the friction wheel's side plates together. See Figure 75.
- Remove the rubber ring from between the plates.
- Reassemble the side plates with a new rubber ring.

NOTE: When reassembling the friction wheel assembly, make sure that the rubber ring is centered and seated properly between the side plates. Tighten each screw only one rotation before turning the wheel clockwise and proceeding with the next screw. Repeat this process several times to ensure the plates are secured with equal force (between 6 ft-lbs and 9 ft-lbs).

- Slide the friction wheel assembly back onto the hex shaft and follow the steps above in reverse order to reassemble components.
- Perform the test previously described in the Drive Control section.

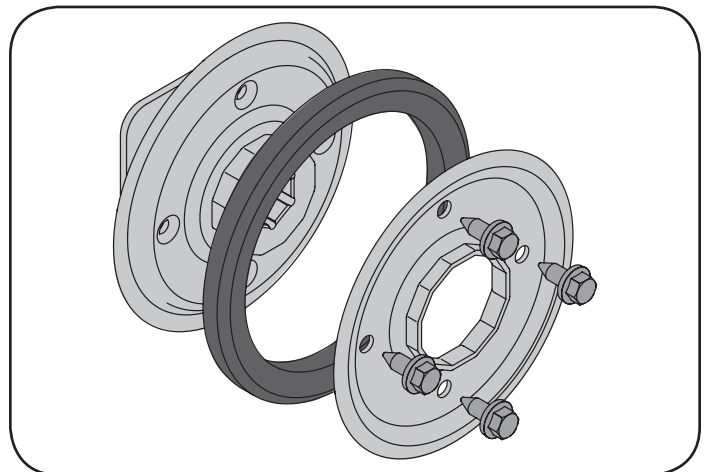

Figure 75

OFF-SEASON STORAGE

If the snow blower will not be used for 30 days or longer, or if the end of the snow season, the equipment needs to be stored properly. Follow storage instructions below to ensure top performance from the snow blower for future use.

Preparing Engine

Engines stored over 30 days need to be drained of fuel to prevent deterioration and gum from forming in fuel system or on essential carburetor parts. If the gasoline in your engine deteriorates during storage, you may need to have the carburetor, and other fuel system components, serviced or replaced.

1. Remove all fuel from tank by running engine until it stops. Do not attempt to pour fuel from the engine.
 2. Change the engine oil.
 3. Remove spark plug and pour approximately 1 oz. (30 ml) of clean engine oil into the cylinder. Pull the recoil starter several times to distribute the oil, and reinstall the spark plug.
 4. Clean debris from around engine, and under, around, and behind muffler. Apply a light film of oil on any areas that are susceptible to rust.
- Store in a clean, dry and well ventilated area away from any appliance that operates with a flame or pilot light, such as a furnace, water heater, or clothes dryer. Avoid any area with a spark producing electric motor, or where power tools are operated.

WARNING

Never store snow blower with fuel in tank indoors or in poorly ventilated areas, where fuel fumes may reach an open flame, spark or pilot light as on a furnace, water heater, clothes dryer or gas appliance.

- If possible, avoid storage areas with high humidity.
- Keep the engine level during storage. Tilting can cause fuel or oil leakage.

Preparing Snow Blower

- When storing the snow blower in an unventilated or metal storage shed, care should be taken to rustproof the equipment. Using a light oil or silicone, coat the equipment, especially any chains, springs, bearings and cables.
- Remove all dirt from exterior of engine and equipment.
- Follow lubrication recommendations.
- Store equipment in a clean, dry area.
- Inflate the tires to the tire manufacturers recommended pressure. Refer to tire sidewall.
- Store snow blower in operating position with both wheels and shave plate on level ground surface.

TROUBLESHOOTING

WARNING

Disconnect the spark plug wire and ground it against the engine to prevent unintended starting. Before performing any type of maintenance/service, disengage all controls and stop the engine. Wait until all moving parts have come to a complete stop. Always wear safety glasses during operation or while performing any adjustments or repairs.

This section addresses minor service issues. To locate the nearest Sears Service Center or to schedule service, call the following toll free number: 1-888-331-4569.

Problem	Cause	Remedy
Engine fails to start	<ol style="list-style-type: none"> 1. Choke control not in CHOKE position. 2. Spark plug wire disconnected. 3. Faulty spark plug. 4. Fuel tank empty or stale fuel. 5. Engine not primed. 6. Safety key not inserted. 7. Extension cord not connected (when using electric start button, on models so equipped). 	<ol style="list-style-type: none"> 1. Move choke control to CHOKE position. 2. Connect wire to spark plug. 3. Clean, adjust gap, or replace. 4. Fill tank with clean, fresh gasoline. 5. Prime engine as instructed in the Operation section. 6. Insert safety key fully into the switch. 7. Connect one end of the extension cord to the electric starter outlet and the other end to a three-prong 120V, grounded, AC outlet.
Engine running erratically/ inconsistent RPM (hunting or surging)	<ol style="list-style-type: none"> 1. Engine running on CHOKE. 2. Stale fuel. 3. Water or dirt in fuel system. 4. Carburetor out of adjustment. 5. Over-governed engine. 	<ol style="list-style-type: none"> 1. Move choke control to RUN position. 2. Fill tank with clean, fresh gasoline. 3. Drain fuel tank by running engine until it stops. Refill with fresh fuel. 4. Contact a Sears or other qualified service dealer for repair. 5. Contact a Sears or other qualified service dealer for repair.
Excessive vibration	<ol style="list-style-type: none"> 1. Loose parts or damaged auger or impeller. 	<ol style="list-style-type: none"> 1. Stop engine immediately and disconnect spark plug wire. Tighten all bolts and nuts. If vibration continues, have unit serviced by a Sears Parts & Repair Center.
Loss of power	<ol style="list-style-type: none"> 1. Spark plug wire loose. 2. Gas cap vent hole plugged. 	<ol style="list-style-type: none"> 1. Connect and tighten spark plug wire. 2. Remove ice and snow from gas cap. Be certain vent hole is clear.
Unit fails to propel itself	<ol style="list-style-type: none"> 1. Drive cable in need of adjustment. 2. Drive belt loose or damaged. 3. Worn friction wheel. 	<ol style="list-style-type: none"> 1. Adjust drive control cable. Refer to Service and Maintenance section. 2. Contact a Sears or other qualified service dealer for repair using identical replacement part. 3. Have friction wheel replaced by a Sears or other qualified service dealer using identical replacement part.

TROUBLESHOOTING

Problem	Cause	Remedy
Unit fails to discharge snow	<ol style="list-style-type: none"> 1. Chute assembly clogged. 2. Foreign object lodged in auger. 3. Auger cable in need of adjustment. 4. Auger belt loose or damaged. 5. Shear pin(s) sheared. 	<ol style="list-style-type: none"> 1. Stop engine immediately and disconnect spark plug wire. Clean chute assembly and inside of auger housing with clean-out tool. 2. Stop engine immediately and disconnect spark plug wire. Remove object from auger with clean-out tool. 3. Adjust auger control cable. Refer to Assembly section. 4. Replace auger belt. Refer to Service and Maintenance section. 5. Replace with new shear pin(s). Refer to Operation section.
Chute fails to easily rotate 180-200 degrees	<ol style="list-style-type: none"> 1. Chute assembled incorrectly. 	<ol style="list-style-type: none"> 1. Disassemble chute control and reassemble as directed in the Assembly section.
Unit plows snow instead of blowing it	<ol style="list-style-type: none"> 1. Low/slow ground speed in wet/slushy snow 1-3" deep. 2. Shear pin(s) sheared. 	<ol style="list-style-type: none"> 1. Increase ground speed. Always operate engine at FULL throttle. 2. Replace with new shear pin(s). Refer to Operation section.
Overhead Chute Crank Does not stay stationary while throwing snow.	<ol style="list-style-type: none"> 1. Insufficient pre-load applied to chute control. 	<ol style="list-style-type: none"> 1. Refer to the Chute under the Service and Maintenance section of this manual.
