



Claryum® Under Sink Water Filter

Owner's Manual



Claryum® 2-Stage



Claryum® 3-Stage



Claryum® 3-Stage Max Flow



Meet clean, healthy water. Your new Aquasana system features Claryum® filtration that removes up to 99.99% of 78 contaminants including microplastics, lead, PFOA/PFOS, pesticides, pharmaceuticals, and chlorine.* Enjoy the peace of mind that comes from knowing our award-winning filter technology is working for you.

AQ-6200, AQ-6300, AQ-6300M

Claryum® Under Sink Water Filter

TABLE OF CONTENTS

Box Contents	1
Care & Safeguards	2
Installation Steps.....	3-6
Filter Replacement.....	7-8
Troubleshooting Guide	9
Performance & Certifications	10-11
Warranty	12
Water for Life® Program.....	13

AQ-6200



Scan or click to view AQ-6200 product and installation videos.

AQ-6300



Scan or click to view AQ-6300 product and installation videos.

AQ-6300M



Scan or click to view AQ-6300M product and installation videos.

*See Performance & Certifications (page 10-11) for specifics about contaminants reduced.

Models with a Regular Dedicated Faucet

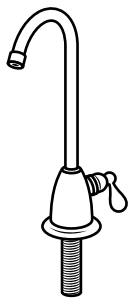

Plastic Tube Insert



Plastic Collar



Chrome Nut



Tubing

AQ-6200 System with System Manifold, Filter Housings & Filters

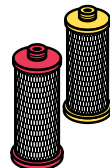
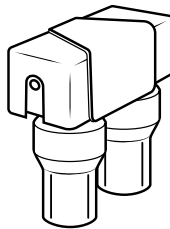

Models with a Pre-Assembled Dedicated Faucet

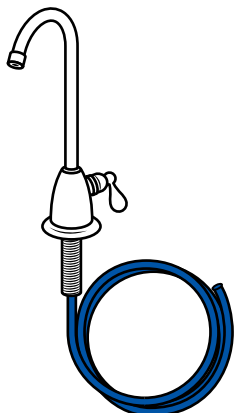

Rubber Washer



Faucet Spacer



Lock Washer



Faucet Nut

AQ-6300 System with System Manifold, Filter Housings & Filters

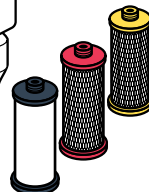
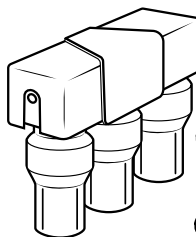

Tubing

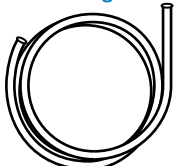

Brass Tube Insert



Plastic Collar



Brass Nut



Screws & Anchors



Brass Tee

AQ-6300M System with System Manifold, Filter Housings & Filters

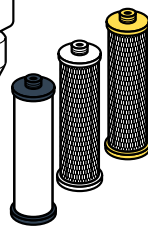
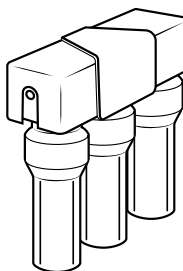

NOTE: If you purchased a system without a dedicated faucet, contents will not include the faucet assembly. If your dedicated faucet comes with tubing attached, then the faucet nut, plastic tube insert, and plastic collar are pre-installed.

Before beginning installation, please ensure all parts listed are present.

If any part is missing or damaged, do not attempt to install the filter.

Please contact Customer Support for replacement parts at **866-662-6885**.

Please read all precautions and instructions carefully before using.

Use and Care

- To clean your system, wipe down the exterior with a damp cloth.
- Do not use any strong or abrasive cleaning agent or solvent cleaner.

NOTICE Important Safeguards

- Do not install this system where the line pressure may exceed 80 psi. The operating pressure range for this filter is between 20-80 psi.
- Install on COLD water lines only (40° - 90°F).
- Use caution when installing the system manifold on a cabinet wall that backs up to a dishwasher. Screws may exceed cabinet width.
- It is recommended that your system be installed inside and out of direct sunlight. The system must be protected from both direct sunlight and freezing temperatures.
- Filter usage must comply with all state and local laws.
- Do not operate without the filters installed.
- Must replace housing every 5 years or risk property damage from leaks. Visit aquasana.com or aquasana.com/water-filter-products to order.
- Do not use with water that is microbiologically unsafe or of unknown water quality without adequate disinfection before or after the system.
- Systems certified for cyst reduction may be used on disinfected waters that may contain filterable cysts.

Battery Notices

- Compatible battery type: CR2450 Lithium Coin Battery
- Compatible battery voltage: 3V
- Ensure batteries are installed correctly according to polarity (+ and -).
- Do not mix old and new batteries, different brands or types of batteries, such as alkaline, carbon-zinc, or rechargeable batteries.
- Non-rechargeable batteries are not to be recharged.
- Do not force discharge, recharge, disassemble, heat above 90°F, or incinerate. Doing so may result in injury due to venting, leakage, or explosion resulting in chemical burns.
- Remove and immediately recycle or dispose of batteries from equipment not used for an extended period of time according to local regulations.
- Always completely secure the battery compartment. If the battery compartment does not close securely, stop using the product, remove the batteries, and keep them away from children.
- Remove and immediately recycle or dispose of used batteries according to local regulations and keep them away from children. Do NOT dispose of batteries in household trash or incinerate them.
- Even used batteries may cause injury or death.
- Call a local poison control center for treatment information.

⚠ WARNING

- **INGESTION HAZARD:** This product contains a button cell or coin battery.
- **DEATH** or serious injury can occur if ingested.
- A swallowed button cell or coin battery can cause **Internal Chemical Burns** in as little as **2 hours**.
- **KEEP** new and used batteries **OUT OF REACH OF CHILDREN**.
- **Seek immediate medical attention** if a battery is suspected to be swallowed or inserted inside any part of the body.



Tools Recommended for Installation:

- Variable Speed Drill w/ 1/8" or 7/32" Bit
- Adjustable Wrench
- Philips Head Screwdriver
- Level
- Pencil
- Measuring Tape
- Bucket
- Hammer
- Safety Glasses

NOTE: This system requires an existing faucet hole at least 1/2" in diameter in the sink or countertop to install the supplied dedicated faucet. You may also replace an existing kitchen sink sprayer, soap dispenser, or use pre-existing hole on the sink or countertop. If using a hole from a current dedicated faucet, ensure the hole is at least 1/2" in diameter.

If drilling a new hole, ensure faucet body will mount flat against surface and there is sufficient tubing between faucet body and system manifold. If drilling, we strongly recommend using a professional. Please wear safety glasses when drilling.

1 Set Up

- A. Unpack and unwrap box contents.
- B. Turn off the cold water supply. Turn on the kitchen faucet to release pressure and allow water to drain from the line.
- C. Disconnect the cold water supply using a wrench.

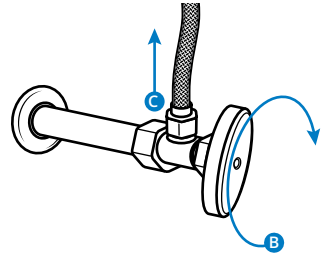

2 Attach Brass Tee and Tubing

- A. Attach threaded ends of brass tee to the cold water supply line and shut-off valve. Tighten with wrench.
- B. Prepare the tubing by sliding the compression nut on the thicker (if applicable) white tubing with the threads of the nut facing the end of the white tube. Next, add the plastic collar (if applicable, wider side should be facing the nut). Finally, insert the brass tee insert into the opening of the tube.
- C. Push the prepared white tubing (with the compression nut, plastic collar, and brass tee insert installed) into the opening of the brass tee.
- D. Slide the compression nut over the plastic collar, then attach to the brass tee. Tighten with a wrench.

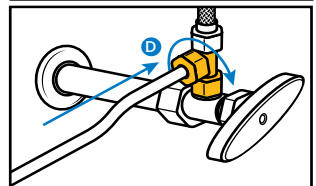
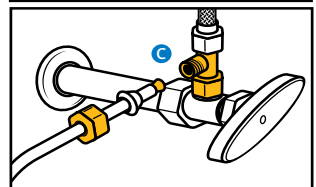
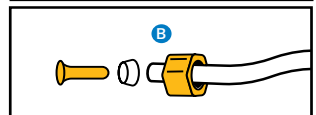
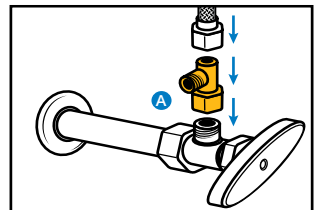

3 Install Dedicated Faucet

NOTE: For Separate Faucet - If you purchased a faucet separately, skip step 3 (Install Dedicated Faucet) and follow the faucet manufacturer's installation manual. Once the faucet is installed, proceed to step 5 (Install System Manifold).

- Slide rubber washer onto dedicated faucet and insert into drilled hole.
- From underneath the sink, slide faucet spacer onto dedicated faucet.
- Slide lock washer onto dedicated faucet.
- Tighten faucet nut to secure faucet to sink.

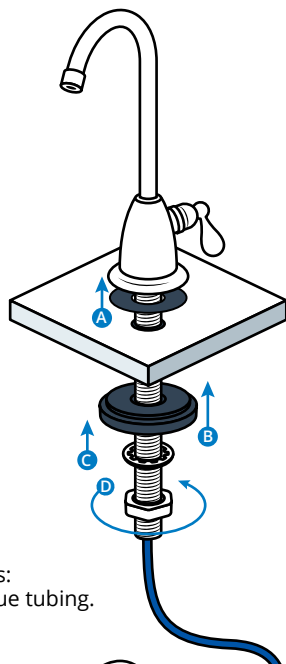

Pre-Assembled Faucets:
Slide parts A-D over blue tubing.

4 Connect Dedicated Faucet

NOTE: Pre-Assembled Faucets: Skip step 4 if your faucet has blue tubing attached.

- Slide the chrome nut onto the thinner (if applicable) white tubing, followed by the plastic collar.
- Press the plastic tube insert into the end of the tubing.
- Press the tubing against the faucet base, and slide the chrome nut and plastic collar up to the threads of the faucet. Use wrench to tighten.

NOTE: Do not over tighten.

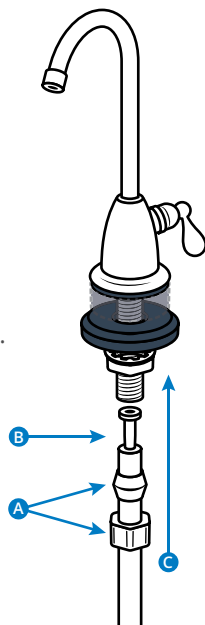

5 Install System Manifold

- A. Select a location under the sink that is at least 12" from the bottom of the cabinet to access system for scheduled filter changes. Do not install filter cartridges at this time.
- B. Use mounting holes located on the back of the system manifold to mark screw placements with pencil.
AQ-6200: 2.6" • AQ-6300: 3.9" • AQ-6300M: 3.9"
- C. Drill pilot holes using a 1/8" bit.
- D. Insert screws into the pilot holes, but do not screw into the wall completely. Hang the manifold on the screws, then tighten the screws.
- E. Pull the protective plastic strip from battery compartment. LED will flash red and beep 5 times to indicate correct battery installation.

NOTE: Select a location that allows easy access to cold water supply and filter replacing.

NOTE: If using anchors, drill pilot holes using a 7/32" bit.

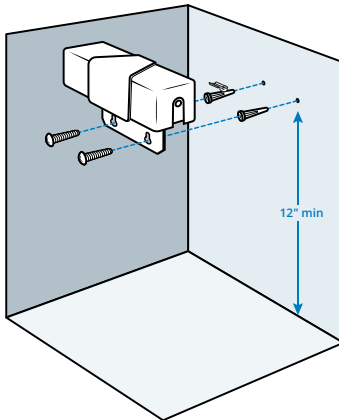

NOTE: If installing the system inside a cabinet next to your dishwasher, use caution when drilling into the cabinet wall.

6 Attach Filter Housings

- A. Attach each filter housing to the bottom of the system manifold. Ensure the connection points are correctly aligned, then push the filter housing up while turning to the right. Turn until you feel a 'click' and the filter housing is locked into place.

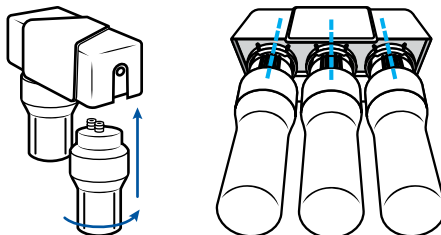

6 INSTALLATION STEPS

- B. Continue this step for the additional filter housing(s) in the sequence noted below for your specific model.

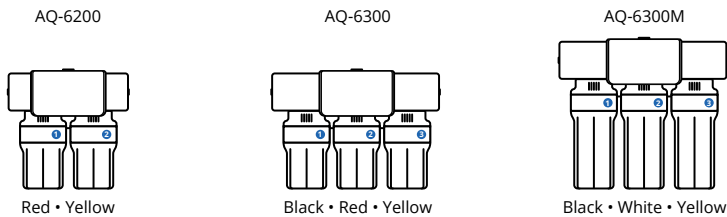

NOTE: Ensure all filter housings are attached and locked in place as pictured above. Ensure the filter housings are not on an angle while attaching, as this could result in leakage or damage to the o-rings. Do not lubricate the o-rings.

7 Connect Water Supply Lines

- A. Mark a line 1" from the end of each tube and push the tubing from the brass tee end into the inlet side (left side).
- B. Mark a line 1" from the end of each tube and push the tubing from the faucet side into the outlet side (right side).

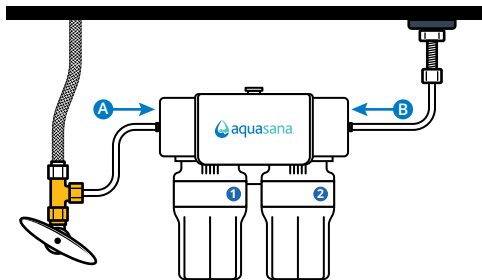

NOTE: Ensure tubing is completely inserted (to a minimum of 1") so leaking does not occur. Wet end of tubing for an easy install into inlets and outlets. Cut excess tubing to prevent crimping, kinks, loops or folds.

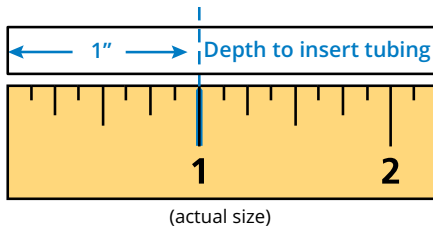

8 Flush System

- A. Turn on cold water and check for leaks.
- B. Flush water for 10 minutes to remove carbon fines.

NOTE: Do not drink flushed water.

Once filters are at 95% capacity (about every 6 months), the battery alarm will sound and indicator light will turn red when water is flowing then will continue to sound for 15 seconds after water is turned off.

NOTE: The battery will need to be replaced every time the filters are replaced. A battery is included with the filter replacement cartridges.

1. Shut off the cold water valve under the sink. Release the pressure from the system by turning on the dedicated faucet. Once there is no longer any water flowing, you can proceed with replacing the filters.
2. Unbox filter replacements and remove plastic. Each filter is color coded to match the color shown on the filter housing.

3. Remove each filter housing from the system manifold by turning the filter housing to the left. Pull down to detach. Ensure the filter housings are not on an angle while removing. This may result in damage to the o-ring.

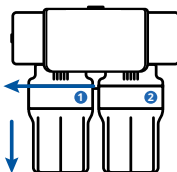

4. Holding the filter housing over the sink, open it by turning the bottom to the left and the cap to the right. Pour excess water down sink drain. Pull down on dirty filter to disconnect it from the filter housing. Continue this step for each filter housing. While the housing is open, inspect each o-ring for damage. If misaligned, gently move the o-ring into place.

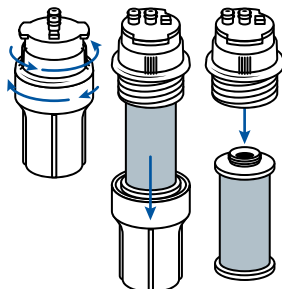

NOTE: If filter housing is too tight to disconnect by hand, please use the plastic wrench included with original system.

NOTE: The filter housing sumps must be replaced every five years. Failure to do so could result in potential leaks due to product deterioration. To order, visit aquasana.com/water-filter-products.

Scan or click to view the Claryum® Under Sink Replacement video.



- Press new replacement filter to the top cap of the filter housing using the appropriate color coded filters. Then, reconnect the bottom of the filter housing to the top cap. Ensure the threads are correctly aligned, then turn the bottom to the right and the cap to the left to tighten. Continue this step for each filter housing.

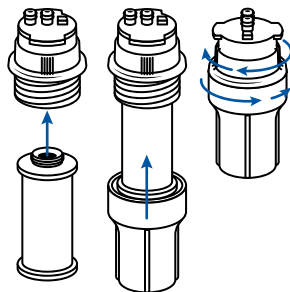

NOTE: Do not use tools to tighten. Hand tighten only.

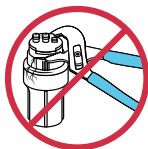

- Reattach each filter housing to the bottom of the system manifold. Ensure connection points are correctly aligned, then push the filter housing up while turning to the right. Turn until you feel a 'click' and the filter housing is locked into place. Continue this step for the additional filter housing(s). Ensure all filter housings are locked in place, are not on an angle, and are aligned as pictured. Improper placement may result in damage to the o-ring or leakage.

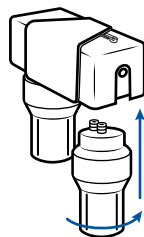

AQ-6200

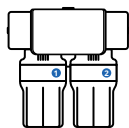

Red • Yellow

AQ-6300

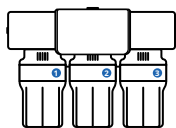

Black • Red • Yellow

AQ-6300M

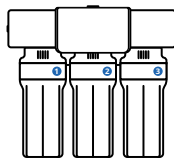

Black • White • Yellow

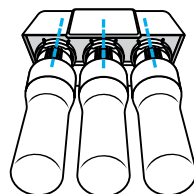

- Open battery compartment and remove old battery tray. Dispose of battery tray per instructions on page 2. Insert new battery tray into battery compartment. When inserted correctly, system will beep five times and blink red.

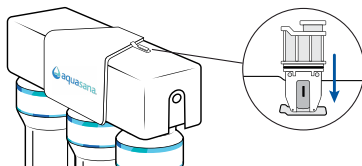

- Once all filter housings have been replaced and attached, slowly turn water valve on. Turn off faucet and inspect for leaks. Then, flush system for 10 minutes before drinking.

NOTE: Do not drink flushed water.

TOPIC	ISSUE	RESOLUTION
Filter Installation	How do I know I connected the filter correctly?	Make sure the filter is properly aligned in the system manifold. There is an arrow on the top cap of the filter that should line up with the center tick mark on the manifold. You should feel a tactile “click” when it’s properly in place.
Filter Replacement	How do I know when to change my filters?	Your system will alert you when it’s time to change the filters — usually every 6 months or after they reach 95% capacity. At that point: <ul style="list-style-type: none"> • The indicator light will turn red when water is flowing. • A beeping sound will occur while water is running and continue for 15 seconds after it stops.
	Why is my system beeping?	A beeping system means it’s time to change your filters. The AQ-6300M system includes a built-in alert that takes the guesswork out of filter replacement.
	I live in a two-person household. Do I still need to replace the filters every 6 months?	Yes. Even in smaller households, we recommend replacing the filters every 6 months to ensure optimal filtration and great-tasting water.
Water Quality	How do I know the system is filtering my drinking water?	The best way to check is to use a water quality test kit or have a licensed professional test your water. This can confirm the system is effectively reducing contaminants.
	What’s the micron rating for each stage of the filtration system?	<ul style="list-style-type: none"> • Pre-filter (if included): 5 microns • Carbon filters: 0.5 sub-micron mechanical filtration
Filter Disposal	How do I dispose of or recycle the filter cartridges?	Our filters are designed to minimize environmental impact: <ul style="list-style-type: none"> • They’re made with over 95% biodegradable carbon and recyclable polypropylene plastic (Class 5). • To recycle: Remove the plastic ends and recycle them, then discard the carbon. It’s landfill-safe and will degrade naturally.
Vacation & Long Absences	I’m going on vacation — what should I do with my filtration system?	If you’ll be away for less than 2 weeks, it’s generally okay to leave the system as-is. For longer trips or added peace of mind, we recommend winterizing the system using the steps provided in your product manual or by contacting our support team.
Refrigerator Compatibility	Can I connect my fridge water line to the filtration system?	Yes! You can either run the line directly to the fridge or use a tee fitting at the outlet going to the faucet. Keep in mind: <ul style="list-style-type: none"> • There may be a drop in water pressure • Use a quick connect fitting, available at stores like Home Depot or Lowe’s • Since our systems aren’t specifically designed for fridges, we can’t provide detailed recommendations beyond this general guidance.
Tubing Included	How much tubing comes with the system?	The amount of tubing included depends on the faucet type you received with your system: <p>Faucet with Tubing Pre-Attached</p> <ul style="list-style-type: none"> • 2-Stage System: (1) 1/4” x 36” tubing • 3-Stage System: (1) 3/8” x 36” tubing • 3-Stage Max Flow System (MF): (1) 3/8” x 36” tubing <p>Faucet with No Tubing Pre-Attached</p> <ul style="list-style-type: none"> • 2-Stage System: (2) 1/4” x 36” tubing • 3-Stage System: (1) 3/8” x 36” tubing and (1) 1/4” x 36” tubing • 3-Stage Max Flow System (MF): (1) 3/8” x 36” tubing and (1) 1/4” x 36” tubing
Faucet Fitting Sizes	What is the size of the chrome nut on the faucet?	The chrome compression nut that connects the tubing to the faucet (for versions without tubing pre-attached) is approximately 13mm (about 0.51”).
	What is the size of the faucet mounting nut?	The small nut used to secure the faucet to your sink or countertop is approximately 14mm (about 0.552”). This size is the same for all versions, whether or not the faucet has tubing pre-attached.

Model	Replacement	Rated Capacity
AQ-6200	AQ-C2-R	500 gallons 1,892 liters
Operating Temp. Range	Operating Pressure Range	Service Flow
40-90° F 4.44-32.2° C	20-80 psi 137.89-551.58 kPa	0.5 gpm 1.9 lpm
<p>Manufactured by: Aquasana, Inc. 6310 Midway Road · Haltom City, Texas 76117 866-662-6885</p>		



System tested and certified by WQA to NSF/ANSI Standards 42, 53, and 401 for the reduction of the claims specified on the Performance Data Sheet and at www.WQA.org.

For the full list of contaminants filtered, scan or click to view the AQ-6200 Performance Data Sheet on Aquasana.com.

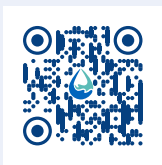

Model	Replacement	Rated Capacity
AQ-6300	AQ-C3-R	600 gallons 2,270 liters
Operating Temp. Range	Operating Pressure Range	Service Flow
40-90° F 4.44-32.2° C	20-80 psi 137.89-551.58 kPa	0.5 gpm 1.9 lpm
Manufactured by: Aquasana, Inc. 6310 Midway Road · Haltom City, Texas 76117 866-662-6885		



System tested and certified by WQA to NSF/ANSI Standards, 42, 53, and 401 for the reduction of the claims specified on the Performance Data Sheet and at www.WQA.org.

For the full list of contaminants filtered, scan or click to view the AQ-6300 Performance Data Sheet on Aquasana.com.



Model	Replacement	Rated Capacity
AQ-6300M	AQ-C3M-R	800 gallons 3,028 liters
Operating Temp. Range	Operating Pressure Range	Service Flow
40-90° F 4.44-32.2° C	20-80 psi 137.89-551.58 kPa	0.72 gpm 2.7 lpm
Manufactured by: Aquasana, Inc. 6310 Midway Road · Haltom City, Texas 76117 866-662-6885		



System tested and certified by WQA to NSF/ANSI Standards, 42, 53, and 401 for the reduction of the claims specified on the Performance Data Sheet and at www.WQA.org.

For the full list of contaminants filtered, scan to view the AQ-6300M Performance Data Sheet on Aquasana.com.





Claryum® 2, 3, and 3+ Stage 1-Year Limited Warranty

WHO IS COVERED

AQUASANA AND ITS SUPPLIERS, (herein collectively referred to as "Manufacturer") warrants to the original owner who purchased and installed the system (hereinafter "Owner"). Registration of the product is not required to receive warranty coverage as specified in this document. If you purchased from an Aquasana-authorized reseller or dealer, proof of purchase is required.

WHAT IS COVERED

This Warranty covers defects in materials or workmanship during the limited Warranty period of your of your Aquasana Water Filtration System including sub-components purchased with original system (may or may not include faucet and fittings), except as provided below. The water filter is warranted only when it is installed, operated and maintained in accordance with the instructions accompanying the water filter found on Aquasana.com. A water filter should be installed in such a manner that, if the system or any connection thereto should leak, the resulting flow of water will not cause damage to the area in which it is installed. For detailed instructions read the manual accompanying the water filter and review drawings in the manual.

FOR HOW LONG

This Warranty runs for 12 months (365 days) from the date of purchase by a consumer (hereinafter "Warranty Period"). No Warranty coverage will be provided if the claimant is unable to provide proof of purchase from an authorized Aquasana reseller. Estimated lifespan of products is for information only and is based on usage approximations. Water conditions and use rates may limit the functional lifespan of your filter. This Limited Warranty does not extend to the full estimated life span of the system.

WHAT AQUASANA WILL DO

1. If necessary, the Manufacturer will provide a replacement that fulfills the remaining estimated lifespan/capacity of your original purchase and send it to you with installation instructions. If industry standards, product improvements or product obsolescence prohibit Manufacturer from furnishing an identical model replacement water filter under this Warranty, the Owner will be furnished with a new water filter of comparable remaining capacity and functionality; however, the Owner will be charged for the additional value of the item(s) which Manufacturer has incorporated in the replacement water filter. The Warranty period for any replacement will run for the balance of the original 365 days.
2. Component Part – If any component part proves to Manufacturer's satisfaction to be defective in material or workmanship within the Warranty period listed on the data plate label, the Manufacturer will furnish the Owner with a replacement for the defective part(s).
3. Return of Defective Water Filter and Component Parts – Manufacturer reserves the right to examine the alleged defect in the water filter or component part(s), and it will be the Owner's obligation to return the water filter and/or component part(s) to the Manufacturer at the Manufacturers request.
 - a. When returning a water filter, it must include all component parts.
 - b. When returning component part(s), they must be individually tagged and identified with the water filter's model number, date of purchase, and date of installation.

WHAT IS NOT COVERED

1. This Warranty does not cover filter cartridges and any systems that were not installed in compliance with the instructions or that have been abused or operated incorrectly.
2. This Warranty applies only to products purchased from Aquasana or an Aquasana-authorized reseller or dealer.
3. Except when specifically prohibited by the applicable state law, the Limited Warranty stated herein is in lieu of any and all warranties, express or implied (whether written or oral), including, but not limited to, the implied warranties of merchantability and fitness for a particular purpose.
4. Except when specifically prohibited by the applicable state

law, the Manufacturer shall not be liable for any incidental, consequential, special, or contingent damages or expenses, arising, directly or indirectly, from any defect in the water filter of the use of the water filter.

5. Manufacturer shall not be liable for any water damage arising, directly or indirectly, from any defect in the water filter or component part(s) or from its use.
6. Manufacturer shall not be liable for any damage or product failures caused by any of the following:
 - The water filter or any of its component parts have been subject to misuse, alteration, neglect or accident.
 - The water filter has not been installed in accordance with the applicable local plumbing and/or building code(s) and/or regulations or in their absence.
 - The water filter is not installed, operated and maintained in accordance with the printed Manufacturer's instructions, including if the water filter has any additional aftermarket equipment introduced into the sealed system not approved by the manufacturer.
 - The water filter is exposed to highly corrosive conditions.
 - The water filter is not continuously supplied with potable water.
 - The water filter is not operated within the factory calibrated temperature limits.
 - The water filter is installed in direct sunlight or exposed to freezing temperatures.
 - The water filter or any of its component parts fail due to sediment build-up.
 - Clogging due to purchaser's failure to replace the filter cartridges.
 - Damage caused by fire, flood or acts of God.
 - Damage caused by over-pressurization in the water line.
7. Manufacturer shall not be liable for any claims related to excessive noise, smell, or taste of water.
8. This Warranty does not cover damage caused by the use of parts that are not genuine Aquasana parts. This includes, but is not limited to replacement filters, faucets, and/or diverter valves.
9. Except when specifically prohibited by the applicable state law, the Owner, and not the Manufacturer, shall be liable for and shall pay for all charges for labor or other expenses incurred in the removal, repair or replacement of the water filter or any component part(s) claimed to be defective or any expense incurred to remedy any defect in the product. Such charges may include, but are not necessarily limited to:
 - a. All freight, shipping, handling and delivery costs of forwarding a new water filter or replacement part(s) to the owner.
 - b. All costs necessary or incidental in removing the defective water filter or component part(s) and installing a new water filter or component part(s).
 - c. Any material required to complete, and/or permits required for, installation of a new water filter or replacement part(s), and
 - d. All costs necessary or incidental in returning the defective water filter or component part(s) to a location designated by the Manufacturer.
10. This warranty provides specific legal rights and limitations, but you may have other rights under applicable state law.

HOW TO GET SERVICE

To receive service under this Warranty, you must contact Aquasana (A. O. Smith Water Treatment (North America), Inc.) at 1-866-662-6885 or support@aquasana.com within the Warranty Period to describe the problem to a customer service representative who will verify that the product is under Warranty and determine whether a part or the system will be replaced and whether you must send back the unit. You will be required to provide both proof of purchase and proper installation.

HOW STATE LAW APPLIES

This Warranty gives you specific rights and you may have other rights which vary from state to state.



water for life®

Protect your investment and save money with Water for Life®.

Our Water for Life® program helps you protect the investment you've made in your family's health with an extended limited warranty on your new filtration system, a 15% discount on replacement filters, and free shipping.



Extended Limited Warranty

Our performance promise to you — free replacement parts when needed.*



Discounted Replacements

The only way to lock in a 15% discount on replacement filters.



Free Shipping

Replacements shipped to you right when you need them — at no extra cost.



No Contract

Free to join and cancel anytime — no long-term commitment required.

CONTACT US TO LEARN MORE



866-275-2319



waterforlife@aquasana.com

*Exclusions apply. Limited Warranty details are available at aquasana.com. Benefits are for the term of Water for Life membership.



LOVE IT?

Please let us know with a review on Aquasana or your retailer's site.



NEED HELP?

Give us a call at **866-662-6885** and tell us what's going on.

Aquasana, Inc.
6310 Midway Road
Haltom City, Texas 76117
866.662.6885 USA
877.332.7873 Canada
www.aquasana.com

100382603
AQ-6000-OM-20250922

