



TOP FREEZER REFRIGERATOR

Use & Care Guide

CONGELADOR SUPERIOR REFRIGERADOR

Guía para el Uso y Cuidado

CONGÉLATEUR SUPÉRIEUR RÉFRIGÉRATEUR

Guide d'Utilisation et d'Entretien

Models / Modelos / Modèles

795.6997*, 795.6991*

795.7997*, 795.7991*

795.6937*, 795.6929*

795.7937*, 795.7929*

* = color number, número de color, numéro de couleur

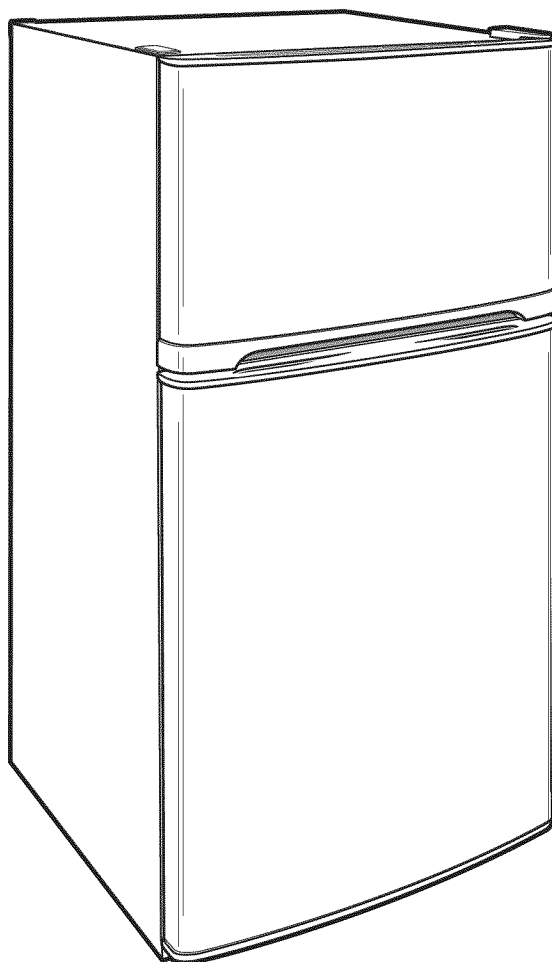

ENGLISH

ESPAÑOL

FRANÇAIS

TABLE OF CONTENTS

Warranty and Product Record	3-4		
		Crisper Humidity Control	20
Safety Instructions	5-6	Door Racks	20-21
		Door Bins	21
Grounding Requirements	6	Dairy Bin/Can Rack	21
		Ice Tray	21
Parts and Features	7		
		Care and Cleaning	22-23
Refrigerator Installation	8-15	General Cleaning Tips	22
Unpacking Your Refrigerator	8	Outside	22
Installation	8	Inside Walls	22
Base Grill	8	Door Liner and Gaskets	22
Removing and Replacing Doors	9-10	Plastic Parts	22
Reversing Doors	10-15	Light Bulb Replacement	22-23
Leveling and Door Closing/ Door Alignment	15	Power Interruptions	23
		Vacation and Moving Care	23
Using Your Refrigerator	16-21	About the Automatic Ice Maker	24
Ensuring Proper Air Circulation	16		
Setting the Controls	16	Connecting the Water Line	25-27
Adjusting Control Settings	17		
Food Storage Guide	17	Troubleshooting Guide	28-31
Storing Frozen Food	18		
Refrigerator Shelves	19-21		
Snack Drawer	19		
Crisper and Crisper Cover	20		



TOP FREEZER REFRIGERATOR

Kenmore Appliance Warranty

One Year Limited Warranty

When installed, operated and maintained according to all instructions supplied with the product, if this appliance fails due to a defect in material or workmanship within one year from the date of purchase, call 1-800-4-MY-HOME® to arrange for free repair.

If this appliance is used for other than private family purposes, this warranty applies for only 90 days from the date of purchase.

This Warranty covers only defects in material and workmanship. Sears will NOT pay for:

1. Expendable items that can wear out from normal use, including but not limited to filters, belts, light bulbs, and bags.
2. A service technician to instruct the user in correct product installation, operation or maintenance.
3. A service technician to clean or maintain this product.
4. Damage to or failure of this product if it is not installed, operated or maintained according to all instructions supplied with the product.
5. Damage to or failure of this product resulting from accident, abuse, misuse or use for other than its intended purpose.
6. Damage to or failure of this product caused by the use of detergents, cleaners, chemicals or utensils other than those recommended in all instructions supplied with the product.
7. Damage to or failure of parts or systems resulting from unauthorized modifications made to this product.

Disclaimer of implied warranties; limitation of remedies

Customer's sole and exclusive remedy under this limited warranty shall be product repair as provided herein. Implied warranties, including warranties of merchantability or fitness for a particular purpose, are limited to one year or the shortest period allowed by law. Sears shall not be liable for incidental or consequential damages. Some states and provinces do not allow the exclusion or limitation of incidental or consequential damages, or limitations on the duration of implied warranties of merchantability or fitness, so these exclusions or limitations may not apply to you.

This warranty applies only while this appliance is used in the United States and Canada.

This warranty gives you specific legal rights, and you may also have other rights which vary from state to state.

**Sears, Roebuck and Co., Hoffman Estates, IL 60179
Sears Canada, Inc., Toronto, Ontario, Canada M5B 2B8**

PROTECTION AGREEMENTS

Master Protection Agreements

Congratulations on making a smart purchase. Your new Kenmore® product is designed and manufactured for years of dependable operation. But like all products, it may require preventive maintenance or repair from time to time. That's when having a Master Protection Agreement can save you money and aggravation.

The Master Protection Agreement also helps extend the life of your new product. Here's what the Agreement* includes:

- Parts and labor** needed to help keep products operating properly **under normal use**, not just defects. Our coverage goes **well beyond the product warranty**. No deductibles, no functional failure excluded from coverage - **real protection**.
- Expert service** by a force of more than 10,000 authorized **Sears service technicians**, which means someone you can trust will be working on your product.
- Unlimited service calls and nationwide service**, as often as you want us, whenever you want us.
- "No-lemon" guarantee** - replacement of your covered product if four or more product failures occur within twelve months.
- Product replacement** if your covered product can't be Fixed.
- Annual Preventive Maintenance Check** at your Request - no extra charge.
- Fast help by phone** - we call it **Rapid Resolution** - phone support from a Sears representative on all products. Think of us as a "talking owner's manual."
- Power surge protection** against electrical damage due to power fluctuations.
- \$250 Food Loss Protection** annually for any food spoilage that is the result of mechanical failure of any covered refrigerator or freezer.
- Rental reimbursement** if repair of your covered product takes longer than promised.
- 10% discount** off the regular price of any non-covered repair service and related installed parts.

Once you purchase the Agreement, a simple phone call is all that it takes for you to schedule service. You can call anytime day or night, or schedule a service appointment online.

The Master Protection Agreement is a risk free purchase. If you cancel for any reason during the product warranty period, we will provide a full refund. Or a prorated refund anytime after the product warranty period expires. Purchase your Master Protection Agreement today!

Some limitations and exclusions apply. For prices and additional information in the U.S.A. call 1-800-827-6655.

***Coverage in Canada varies on some items. For full details call Sears Canada at 1-800-361-6655.**

Sears Installation Service

For Sears professional installation of home appliances, garage door openers, water heaters, and other major home items, in the U.S.A. or Canada call **1-800-4-MY-HOME®**.

PRODUCT RECORD

In the space below, record the date of purchase, model and serial number of your product. You will find the model and serial number printed on an identification label located on the right-hand side of the refrigerator compartment. Have these items of information available whenever you contact Sears concerning your product.

Model No. _____

Date of Purchase _____

Serial No. _____

Dealer _____

Save these instructions and attach your sales receipt for future reference.

IMPORTANT SAFETY INSTRUCTIONS

SAFETY MESSAGES

This guide contains many important safety messages. Always read and obey all safety messages.



This is the safety alert symbol. It alerts you to safety messages that inform you of hazards that can kill or hurt you or others, or cause damage to the product.

All safety messages will be preceded by the safety alert symbol and the hazard signal word DANGER, WARNING or CAUTION. These words mean:



DANGER

You **will** be killed or seriously injured if you don't follow instructions.



WARNING

You **can** be killed or seriously injured if you don't follow instructions.



CAUTION

Indicates an imminently hazardous situation which, if not avoided, **may** result in minor or moderate injury, or product damage only.

All safety messages will identify the hazard, tell you how to reduce the chance of injury and tell you what can happen if the instructions are not followed.

⚠️ WARNING

To reduce the risk of fire, electric shock or injury to persons when using your product, basic safety precautions should be followed, including the following:

- NEVER unplug your refrigerator by pulling on the power cord. Always grip the plug firmly and pull it straight out from the outlet.
- Repair or replace immediately all electric service cords that have become frayed or otherwise damaged. Do not use a cord that shows cracks or abrasion damage along its length or at either the plug or connector end.
- When moving your refrigerator away from the wall, be careful not to roll over or damage the power cord.
- DO NOT store or use gasoline or other flammable vapors and liquids in the vicinity of this or any other appliance.
- DO NOT allow children to climb, stand or hang on the refrigerator doors or shelves in the refrigerator. They could damage the refrigerator and seriously injure themselves.
- Keep fingers out of "pinch point" areas; clearances between the doors and between the doors and cabinet are necessarily small. Be careful closing doors when children are in the area.
- Unplug your refrigerator before cleaning or making any repairs. **NOTE:** We strongly recommend that any servicing be performed by a qualified individual.
- Before replacing a burned-out light bulb, unplug the refrigerator or turn off power at the circuit breaker or fuse box in order to avoid contact with a live wire filament. (A burned-out light bulb may break when being replaced.) **NOTE:** Setting either or both controls to the OFF position does not remove power to the light circuit.
- Do not store bottles in the freezer compartment - they may break when frozen, causing damage.

- For personal safety, this appliance must be properly grounded. Have the wall outlet and the circuit checked by a qualified electrician to make sure the outlet is properly grounded.
- Read all instructions before using this appliance.
- Use this appliance only for its intended purpose as described in this use and care guide.
- This refrigerator must be properly installed in accordance with the Attention Installer Instructions that were taped to the front of the refrigerator.
- After your refrigerator is in operation, do not touch the cold surfaces in the freezer compartment when hands are damp or wet. Skin may adhere to the extremely cold surfaces.
- In refrigerators with automatic icemakers, avoid contact with the moving parts of the ejector mechanism, or with the heating element that releases the cubes. DO NOT place fingers or hands on the automatic icemaking mechanism while the refrigerator is plugged in.
- DO NOT refreeze frozen foods which have thawed completely. The United States Department of Agriculture in Home and Garden Bulletin No. 69 says:
"...You may safely refreeze frozen foods that have thawed if they still contain ice crystals or if they are still cold below 40°F (4°C)."
"...Thawed ground meats, poultry or fish that have any off-odor or off-color should not be refrozen and should not be eaten. Thawed ice cream should be discarded. If the odor or color of any food is poor or questionable, get rid of it. The food may be dangerous to eat."
"Even partial thawing and refreezing reduces the eating quality of foods, particularly fruits, vegetables and prepared foods. The eating quality of red meats is affected less than that of many other foods. Use refrozen foods as soon as possible to save as much of their eating quality as you can."

SAVE THESE INSTRUCTIONS

⚠ CAUTION

This appliance is not intended for use by persons (including children) with reduce physical, sensory or mental capabilities, or lack of experience and knowledge, unless they have been given supervision or instruction concerning use of the appliance by person responsible for their safety.

Children should be supervised to ensure that they do not play with the appliance.

⚠ DANGER: RISK OF CHILD ENTRAPMENT

Child entrapment and suffocation are not problems of the past. Junked or abandoned refrigerators are still dangerous... even if they will sit for "just a few days". If you are getting rid of your old refrigerator, please follow the instructions at right to help prevent accidents.

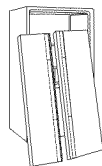

Before you throw away your old Refrigerator or freezer:

- Take off the doors.
- Leave the shelves in place so that children may not easily climb inside.

CFC DISPOSAL

Your old refrigerator may have a cooling system that used CFCs (chlorofluorocarbons). CFCs are believed to harm stratospheric ozone. If you are throwing away your old refrigerator, make sure the CFC refrigerant is removed for proper disposal by a qualified servicer. If you intentionally release this CFC refrigerant, you can be subject to fines and imprisonment under provisions

of environmental legislation. This appliance contains fluid (refrigerant, lubricant), and is made of parts and materials which are reusable and / or recyclable. All the important materials should be sent to the collection center of waste material and can be reused after rework (recycling). To recycle, please contact your local agency.

GROUNDING REQUIREMENTS

IMPORTANT: Please read carefully.

TO CONNECT ELECTRICITY

⚠ WARNING

Electrical Shock Hazard

FOR PERSONAL SAFETY, this appliance must be properly grounded. Have the wall outlet and the circuit checked by a qualified electrician to make sure the outlet is properly grounded.

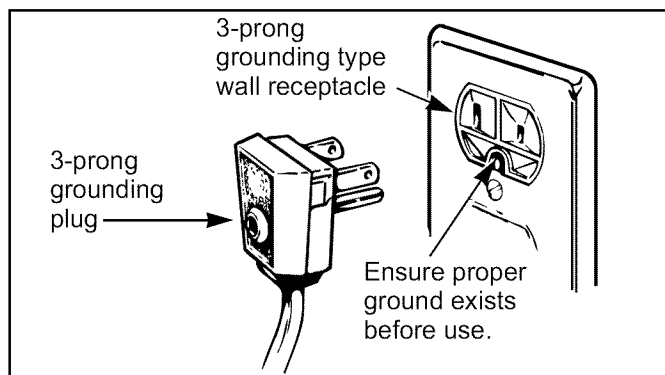

USE OF EXTENSION CORDS

Because of potential safety hazards under certain conditions, we strongly recommend against the use of an extension cord. However, if you still elect to use an extension cord, it is absolutely necessary that it be a UL-listed (in the United States), 3-wire grounding type appliance extension cord having a grounding type plug and outlet, and that the electrical rating of the cord be 15 amperes (minimum) and 120 volts.

Use of an extension cord will increase the clearance needed for the back of the refrigerator. If the supply cord is damaged, it must be replaced by the manufacturer or its service agent or a similarly qualified person in order to avoid any hazard.

RECOMMENDED GROUNDING METHOD

The refrigerator should always be plugged into its own individual properly grounded electrical outlet rated for 115 volts, 60Hz, AC only and fused at 15 or 20 amperes. This provides the best performance and also prevents overloading house wiring circuits which could cause a fire hazard from overheated wires. It is recommended that a separate circuit serving only this appliance be provided. Use a receptacle which cannot be turned off with a switch or pull chain. Do not use an extension cord.

Where a standard two-prong wall outlet is encountered, it is your personal responsibility and obligation to have it replaced with a properly grounded three-prong wall outlet. Do not, under any circumstances, cut or remove the third (Ground) prong from the power cord.

NOTE: Before performing any type of installation, cleaning, or removing a light bulb, turn the control (Thermostat, Refrigerator Control or Freezer Control, depending on the model) to OFF and then disconnect the refrigerator from the electrical source. When you are finished, reconnect the refrigerator to the electrical source and reset the control (thermostat, refrigerator control or freezer control, depending on the model) to the desired setting.

PARTS AND FEATURES

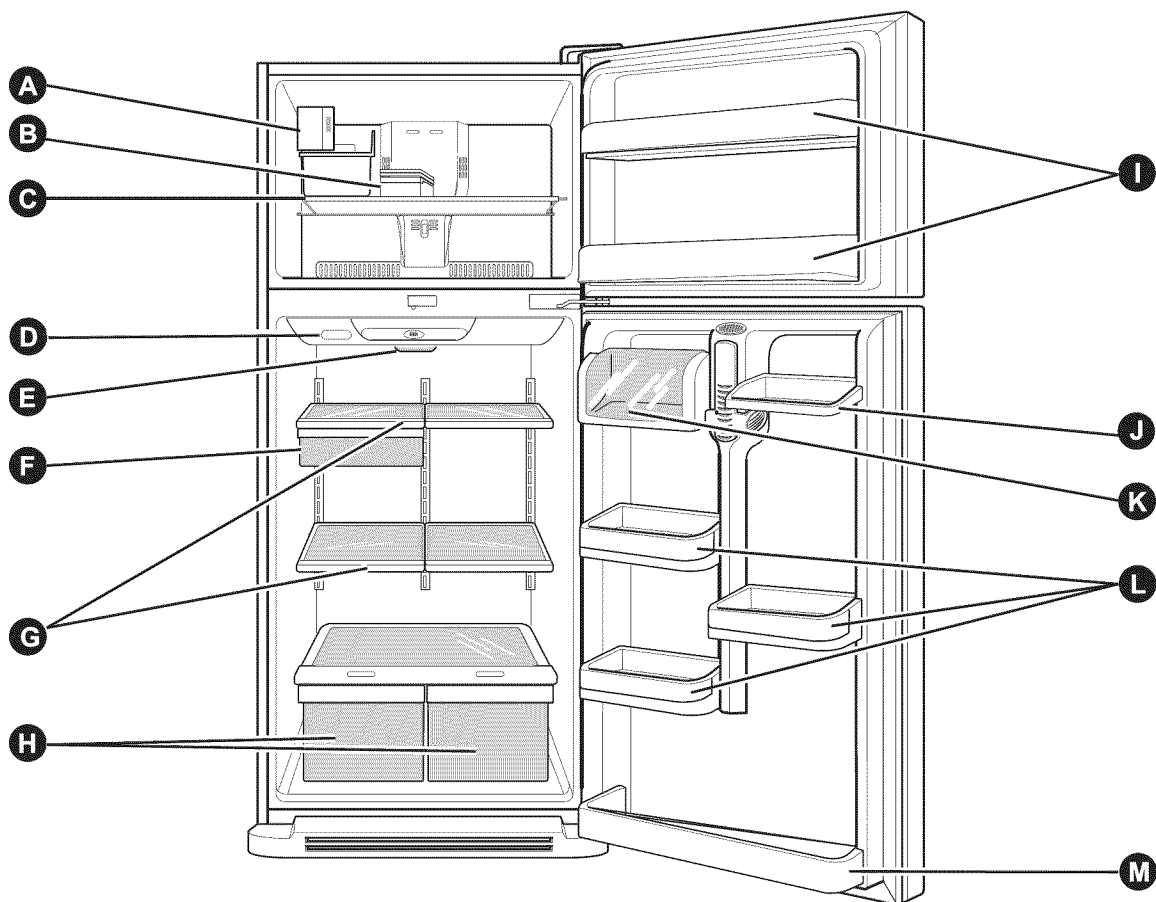

Use this section to become more familiar with the parts and features. Page references are included for your convenience.

NOTE: This guide covers several different models. The refrigerator you have purchased may have some or all of the items listed below. The locations of the features shown below may not match your model.

A CustomCube Ice maker *

B Ice Bin *

C Freezer Shelf

D Digital Temperature Control

E Refrigerator Light

F Snack Drawer

G Shelves

H Crispers
Keeps fruits and vegetables fresh and crisp

I Freezer Door Racks

J Can Rack *

K Dairy Bin

L Door Bins

M Refrigerator Door Rack

*On some models

REFRIGERATOR INSTALLATION

⚠ WARNING

Excessive Weight Hazard

Use two or more people to move and install refrigerator.
Failure to do so can result in back or other injury.

UNPACKING YOUR REFRIGERATOR

Remove tape and any temporary labels from your refrigerator before using. Do not remove any warning-type labels or the model and serial number label.

To remove any remaining tape or glue, rub the area briskly with your thumb. Tape or glue residue can also be easily removed by rubbing a small amount of liquid dish soap over the adhesive with your fingers. Wipe with warm water and dry.

Do not use sharp instruments, rubbing alcohol, flammable fluids, or abrasive cleaners to remove tape or glue. These products can damage the surface of your refrigerator. For more information, see the **Important Safety Instructions section**.

Refrigerator shelves are installed in the shipping position. Please reinstall shelves according to your individual storage needs.

⚠ WARNING

When Moving Your Refrigerator:

Your refrigerator is heavy. When moving the refrigerator for cleaning or service, be sure to protect the floor. Always pull the refrigerator straight out when moving it. Do not wiggle or walk the refrigerator when trying to move it, as floor damage could occur.

⚠ WARNING

Explosion Hazard

Keep flammable materials and vapors, such as gasoline, away from refrigerator.

Failure to do so can result in death, explosion or fire.

INSTALLATION

1. Avoid placing unit near heat sources, direct sunlight or moisture.
2. To minimize noise and vibration, the refrigerator **MUST** be installed on a solidly constructed floor.
3. Carpeting and soft tile surfaces are not recommended.
4. **NEVER** install the refrigerator on a platform or a weakly supported structure.
5. Install this appliance in an area where the temperature is between 55 °F (13 °C) and 110 °F (43 °C.) If the temperature around the appliance is too low or high, cooling ability may be adversely affected.

NOTE: For proper air circulation, best cooling and energy consumption results, maintain a minimum distance of 2 inches (5.08cm) from adjacent items and surfaces.

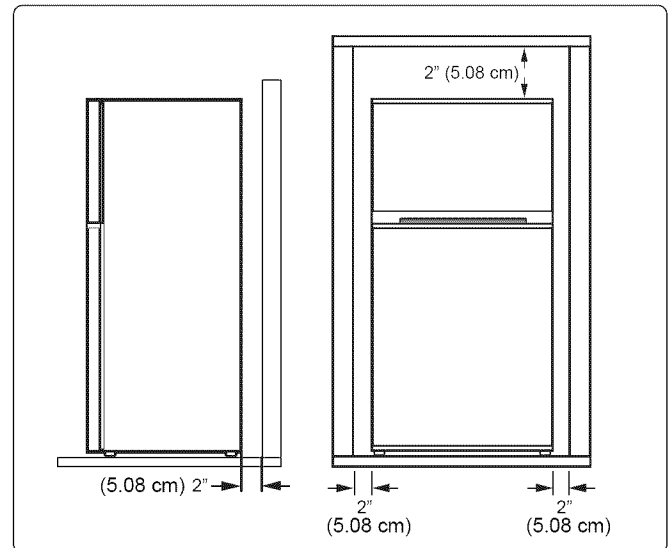

⚠ WARNING

- Be careful when you work with hinge, base grille, stopper etc. You may be injured.
- Do not put hands or metal sticks into air vents, base grille or bottom of refrigerator. You may be injured or receive an electrical shock.

BASE GRILLE INSTALLATION

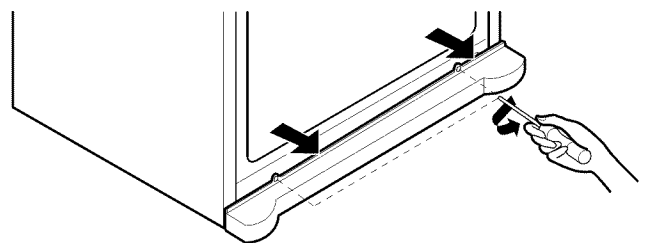

To install or replace Base Grille:

1. Open Refrigerator door.
2. Remove the 2 screws from the bottom front part of Refrigerator.
3. Place Base Grille into position and insert and tighten screws.

To remove the Base Grille

1. Open refrigerator door.
2. Remove screws from Base Grille and remove.
3. Reattach screws to the base of refrigerator.

REFRIGERATOR INSTALLATION

⚠ WARNING

ELECTRICAL SHOCK HAZARD

Before you begin, either unplug the refrigerator or turn off power at the circuit breaker or fuse box. Remove food and any Adjustable Door or Utility Bins from doors. Failure to do so could result in death or serious injury.

REMOVING AND REPLACING DOORS

If entrance is less than 35-inches wide, the refrigerator's doors will need to be removed.

TOOLS NEEDED:

- 10mm or 13/32-inch socket wrench (with 2-inch extension for bottom door hinge)
- No. 2 Phillips head screwdriver
- Flat-head screwdriver for prying

REMOVE FREEZER DOOR

- Gently pry off the Top Hinge Cover with a flat head screwdriver and remove (see Fig 1).

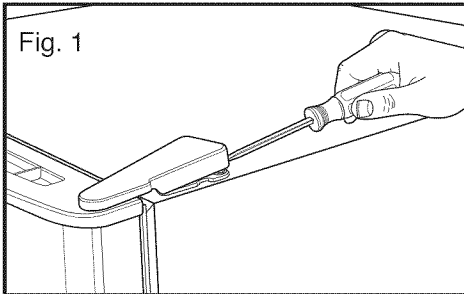

- Using 10mm or 13/32-inch socket wrench, remove the 3 bolts and lift off the Top Hinge (see Fig. 2). Set parts aside.

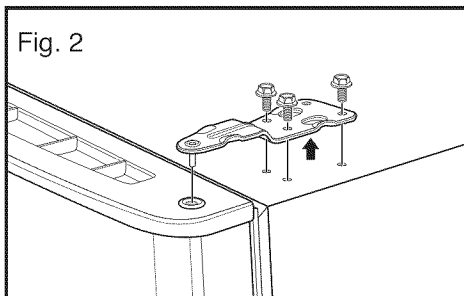

- Lift freezer door slightly and remove it. (Fig. 3). Set aside.

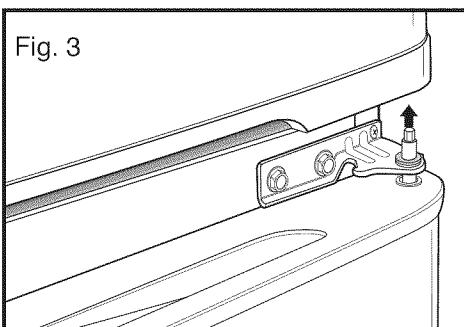

REMOVE REFRIGERATOR DOOR

- Loosen and remove the 2 bolts and the phillips head screw to remove the Middle Hinge Bracket from refrigerator housing (Fig. 4 and 5). Set parts aside.

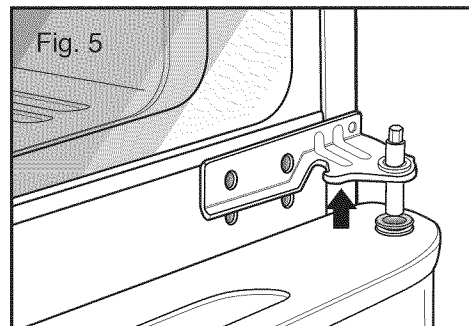
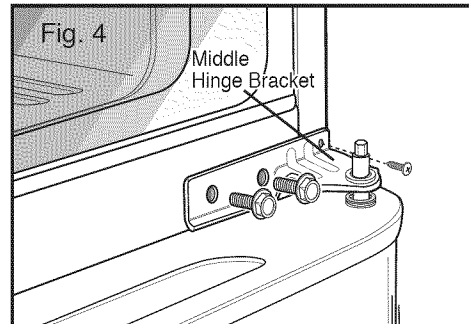

- Lift up door slightly and remove it.

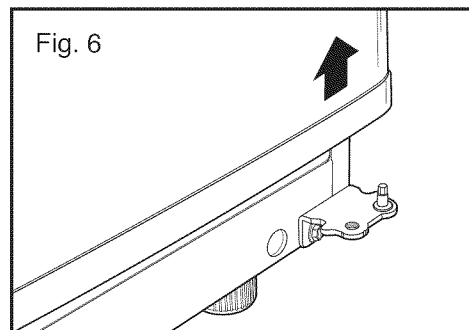

To replace doors, begin with refrigerator door and then follow with freezer door.

REFRIGERATOR INSTALLATION

REPLACE REFRIGERATOR DOOR

- Set door onto Bottom Hinge Pin.
- Place Hinge Pin of Middle Hinge Bracket inside Hinge Pin Insert on top of door (Fig. 7). Hold door in place and line up the Middle Hinge Bracket with the holes in refrigerator housing.

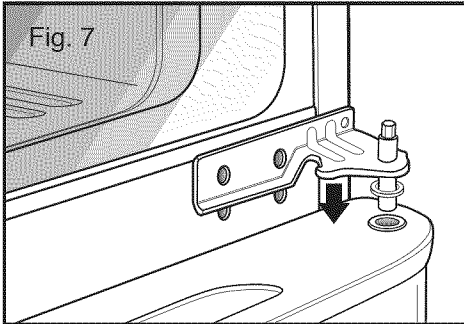

- Use the 2 bolts and phillips screw to refasten the Middle Hinge Bracket and door to the refrigerator housing. (Fig. 8).

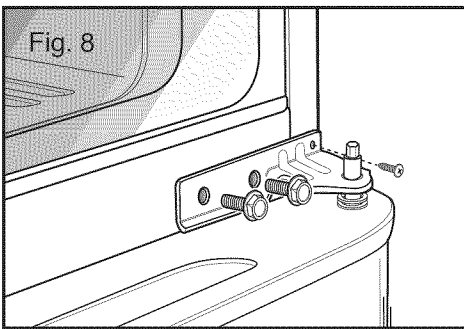

REPLACE FREEZER DOOR

- Set the freezer door onto the Middle Hinge Pin (Fig. 9).

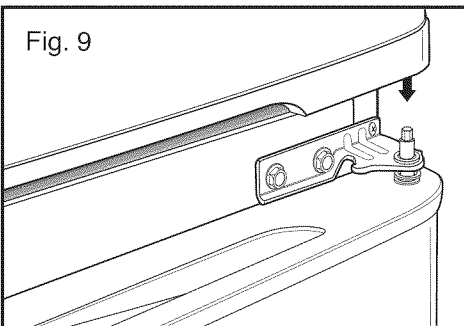

- Place Upper Hinge's Pin in the top of freezer door and line up the Upper Hinge with holes in top of refrigerator. Use the 3 bolts to replace Hinge (Fig. 10).

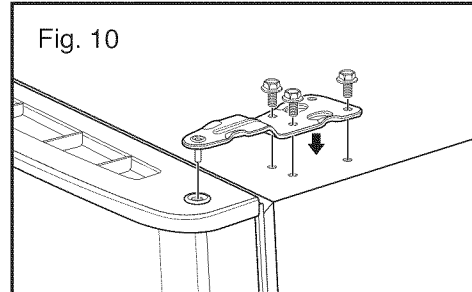

- Carefully force-fit Top Hinge Cover back into place over Hinge (Fig.11).

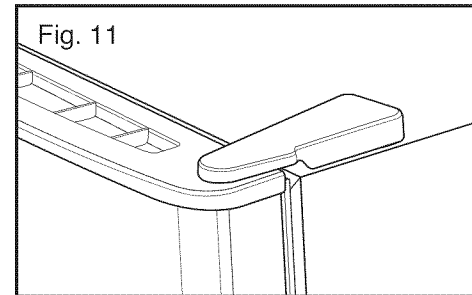

⚠ WARNING

ELECTRICAL SHOCK HAZARD

Before you begin, either unplug the refrigerator or turn off power at the circuit breaker or fuse box. Remove food and any Adjustable Door or Utility Bins from doors. Failure to do so could result in death or serious injury.

REVERSING DOORS

You may find it more convenient to have the doors converted from the left-opening type (factory installed) to the right-opening type. Directions refer to the right side as the side on your right as you face the unit.

TOOLS NEEDED

- 10mm or 13/32-inch socket wrench (with 2-inch extension for bottom door hinge)
- No. 2 Phillips head screwdriver
- ¼ inch socket wrench
- Flat-head screwdriver for prying

REFRIGERATOR INSTALLATION

REVERSE FREEZER DOOR

- Gently pry off the Top Hinge Cover with a flat head screwdriver and remove (see Fig.13).

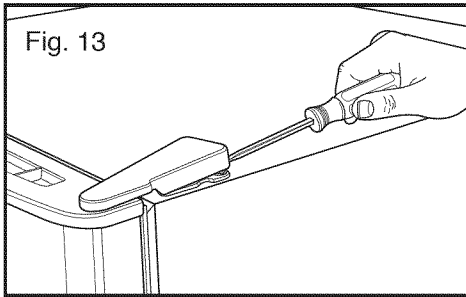

- Using 10mm or 13/32-inch socket wrench, remove the 3 bolts and lift off the Top Hinge (see Fig. 14). Set parts aside.

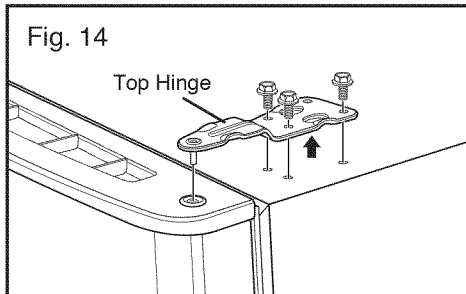

- Lift up door slightly and remove it (Fig. 15).

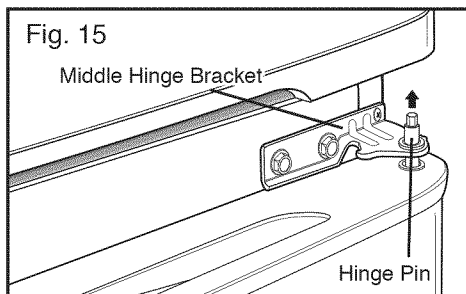

- Turn freezer door upside down on a non-scratch surface and loosen the screw to remove Door Closer/Stop and Hinge Pin Insert (see Fig. 16).

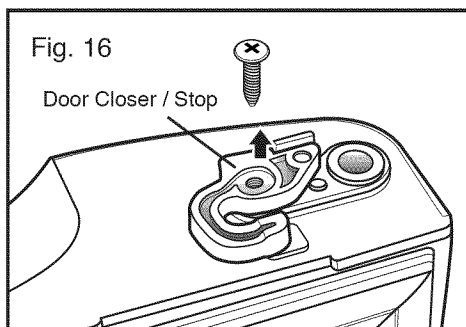

- Move the Hinge Pin Insert Bracket to the other side of the door, keeping the same orientation, and move the Hinge Pin Insert into the hole on the left side of the bracket (Fig. 17).

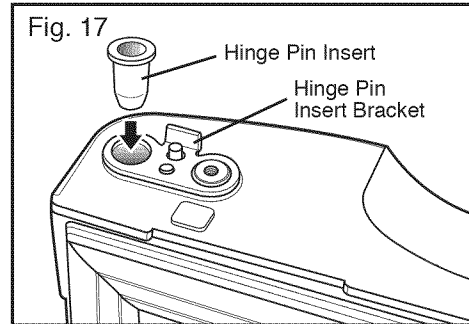

- Reverse Door Closer/Stop by flipping over (see Fig. 18), place on top of Hinge Pin Insert Bracket, and tighten both down with the screw.

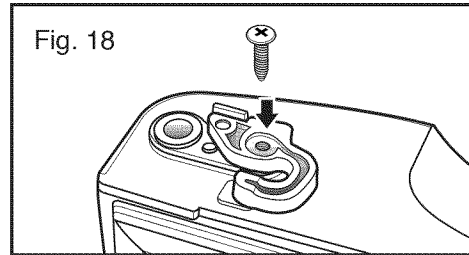

- Pry off cover on top of refrigerator on left side to uncover screw holes (Fig. 19).
- Set freezer door and Top Hinge parts to the side and remove refrigerator door.

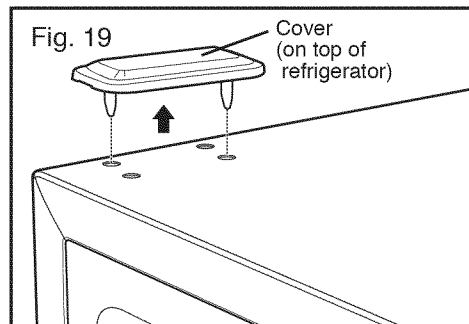

REFRIGERATOR INSTALLATION

REVERSE AND REATTACH REFRIGERATOR DOOR

- Using a 1/4-inch socket wrench, loosen and remove Hinge Pin from the Middle Hinge Pin Bracket. Remove washer underneath the middle hinge and set aside.

NOTE: At this point the door will be loose, lift up door slightly and remove it. (Fig. 20 and 20a).

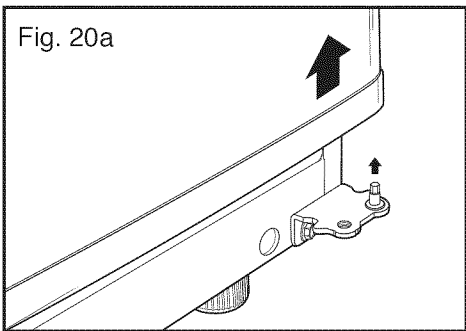
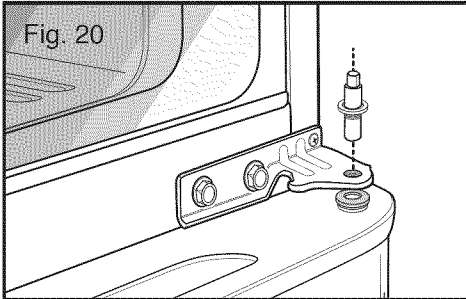

- Loosen and remove the 2 bolts and the phillips head screw to remove the Middle Hinge Bracket from refrigerator housing (Fig. 21). Set parts aside.

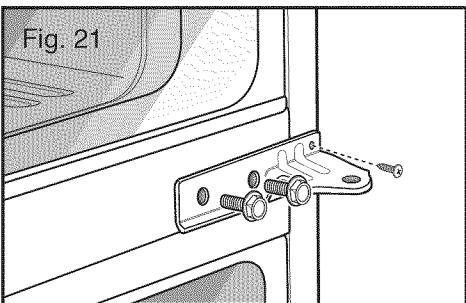

- REMOVE** base grill. See **BASE GRILL INSTRUCTIONS** on page 8.
- Remove the washer from the Bottom Hinge Pin (Fig. 22).
- Using a 1/4-inch socket wrench, loosen and remove the Hinge Pin from the Bottom Hinge. Reattach the Hinge Pin to the opposite side of the Hinge (see Fig. 22 and 22a). **NOTE:** This is easier to do while the Hinge is still attached.

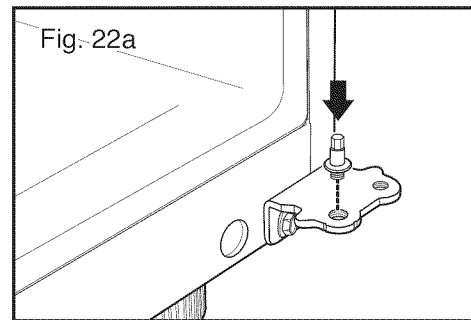
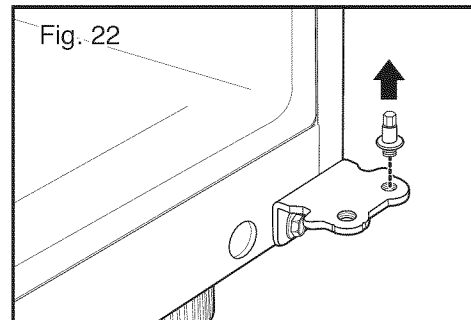

- Using 10mm or 13/32-inch socket wrench with 2-inch extension, loosen the 3 bolts and remove the Bottom Hinge from right side of housing (Fig. 23).

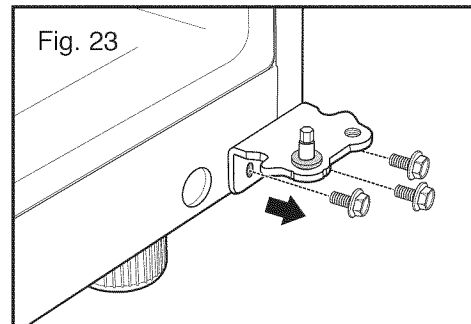

REFRIGERATOR INSTALLATION

- At this point, remove the Decorative Bolt on bottom on refrigerator housing from the left side of refrigerator (Fig. 24). You will need this hole for the Bottom Hinge.

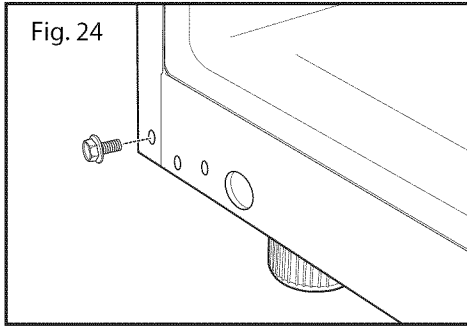

- Move the Bottom Hinge to the left side of housing keeping the same orientation, and reattach with 3 bolts (Fig. 25). Now move Decorative Bolt to hole on lower right side of housing.

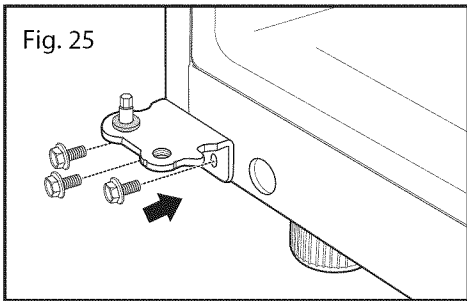

- Turn refrigerator door upside down on a non-scratching surface.
- With door upside down, loosen the 2 screws and remove the Door Closer/Stop (Fig. 26), then loosen the other two screws to remove the bottom Hinge Pin Insert Bracket with Hinge Pin Insert (see Fig. 27).

NOTE: The Refrigerator Door Closer/Stop is not used on all models. The model you have may not include this part.

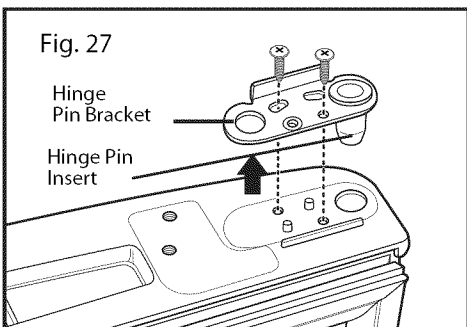
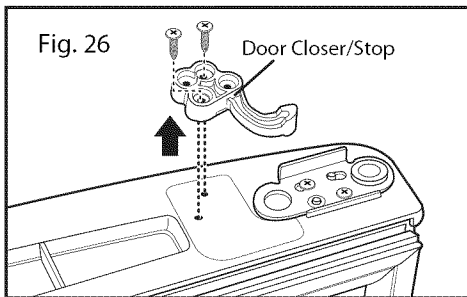

- Take out the Hinge Pin Insert and move the Bracket to the other side of the door, keeping the same orientation (Fig. 28).
- Place Hinge Pin Insert into the left side of the bracket. Tighten Hinge Pin Bracket to door (Fig. 28).

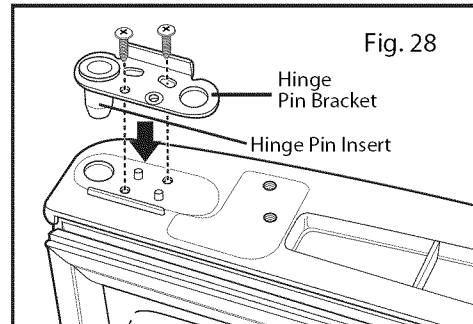

- Take Door Closer/stop and flip (see Fig. 29). Line up screw holes and mount on left side of door bottom with the two screws. Turn door upright. It is now ready for re-attaching.

NOTE: The Refrigerator Door Closer/Stop is not used on all models. The model you have may not include this part.

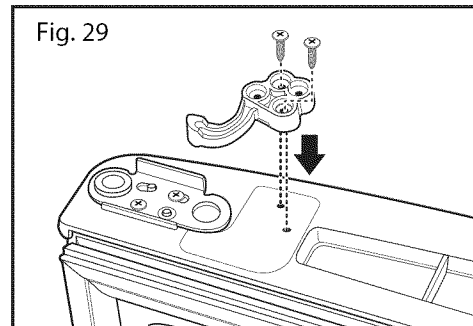

- With flat-head screwdriver, carefully pry off and remove the cover over the screw holes on the left side of refrigerator housing (Fig. 30).

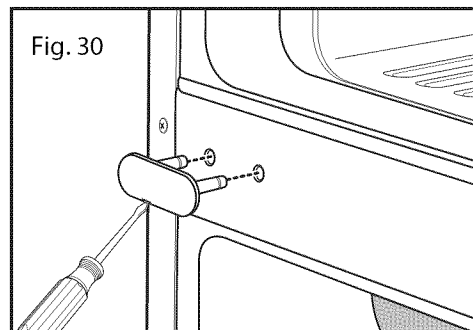

REFRIGERATOR INSTALLATION

- Remove the outer lower Decorative Screw from housing at area between freezer and refrigerator doors (Fig. 31). (You will need this hole for the Middle Hinge Bracket).

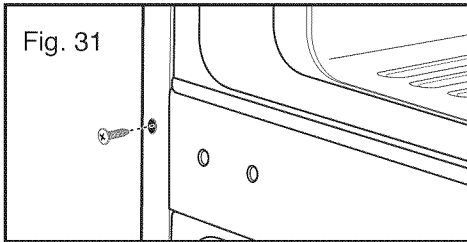

- Following illustration, flip the Middle Hinge Bracket (Flange will now be on top) and position on left side of refrigerator and re-attach with two bolts and a Phillips screw. (Fig. 32).
- Place refrigerator door down over pin on bottom hinge. (Fig. 32).
- Place washer between refrigerator door and middle hinge and re-attach Hinge Pin to Hinge Bracket with 1/4-in. socket wrench. **NOTE:** Bracket has been flipped, but Hinge Pin stays in the same orientation with its hexagonal end facing upward (Fig. 32).

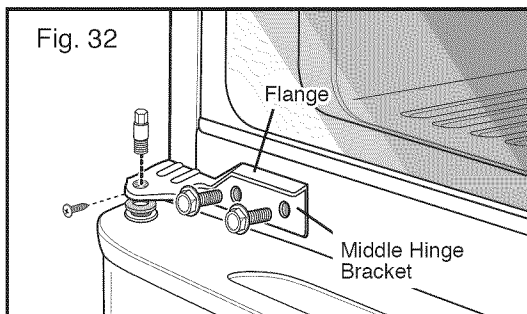

- Place Decorative Screw into outer hole on right side of housing (Fig. 33).
- Attach cover on the right side. Cover is force-fitted (Fig. 33).

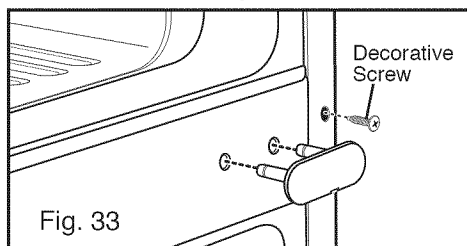

- Place Upper Hinge's Pin in the top of freezer door and line up the Upper Hinge with holes in top of refrigerator. Use the 3 bolts to replace Hinge (Fig. 35).

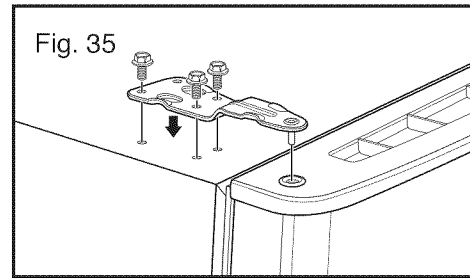

- Tighten bolts. Force-fit Top Hinge Cover over Top Hinge (Fig. 36).

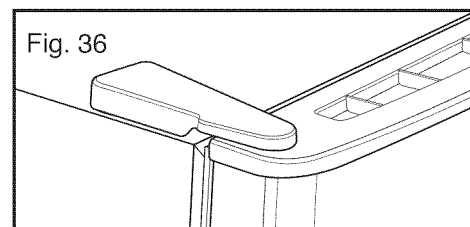

- Replace cover from left side of refrigerator top onto the right of top to cover the holes. Cover is also force-fitted (Fig. 37).

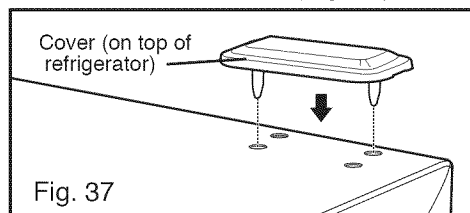

After changing doors, make sure that the corners of the Door Gaskets are not folded over (see Fig. 38). To ensure a good seal, apply a small amount of silicon grease on the corners of gaskets.

Fig. 38

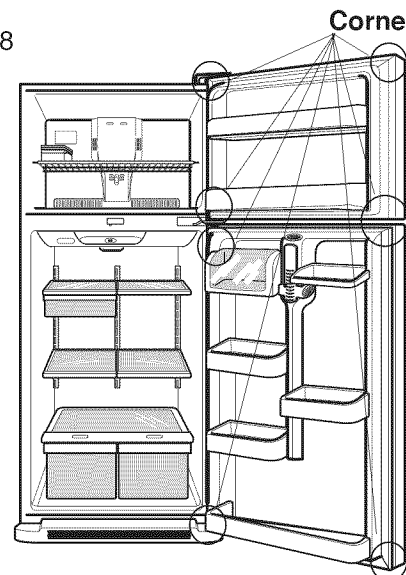

REATTACHING FREEZER DOOR

- Put freezer door down over the Hinge Pin on the Middle Hinge Pin Bracket (Fig. 34).

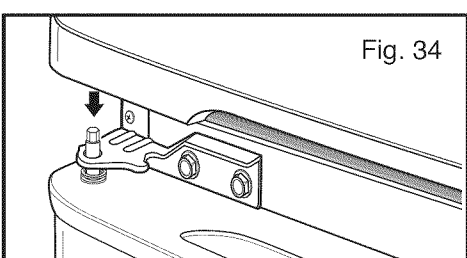

REFRIGERATOR INSTALLATION

LEVELING AND DOOR CLOSING

To avoid vibration, the unit must be leveled. If necessary, adjust the Leveling Legs to compensate for unevenness of the floor. The front should be slightly higher than the rear to aid in door closing.

Your refrigerator has two Front Leveling Screws – one on the right and one on the left. If your refrigerator seems unsteady or you want the doors to close more easily, adjust the refrigerator's tilt using the instructions below:

1. Plug refrigerator power cord into a 3-prong grounded outlet. Move the refrigerator into its final position.
2. Remove the base grill. See **BASE GRILL INSTRUCTIONS** on page 8. The two Leveling Screws are located on the bottom of the refrigerator on either side (see Fig. 39).
3. Insert a flat screwdriver in slots to adjust the Leveling Screws (Fig. 39). Turn the leveling screw clockwise to raise that side of the refrigerator or counterclockwise to lower it. It may take several turns of the Leveling Screw to adjust the tilt of the refrigerator.

NOTE: Having someone push against the top of the refrigerator takes some of the weight off the Leveling Screws. This makes it easier to adjust the screws.

Fig. 39

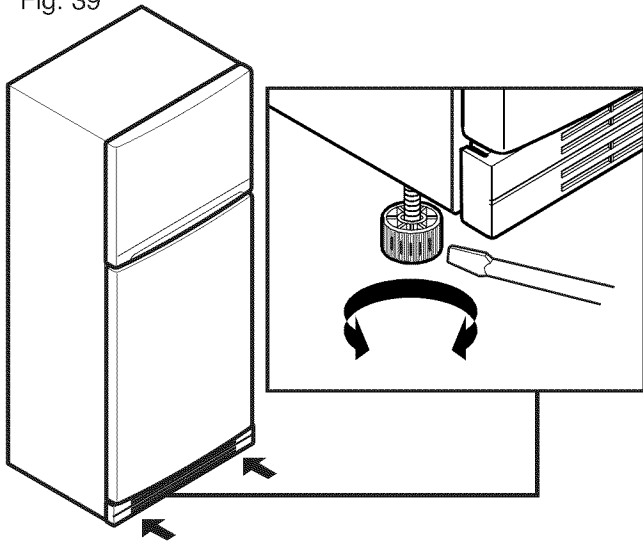

4. Open both doors again and check to make sure that they close easily. If not, tilt the refrigerator slightly more to the rear by turning both Leveling Screws clockwise. It may take several more turns, and you should turn both Leveling Screws the same amount.
5. Replace the base grill.

DOOR ALIGNMENT

If the space between your doors is uneven, follow the instructions below to align the doors:

1. Gently pry off the Top Hinge Cover with a flat head screwdriver and remove. Loosen the Top Hinge Bolts using a 10mm or 13/32-in. socket wrench or open-end wrench.
2. Have someone hold the freezer door so the space between the two doors is even, and retighten the top hinge bolts.
3. Replace the Top Hinge Cover.

USING YOUR REFRIGERATOR

ENSURING PROPER AIR CIRCULATION

In order to ensure proper temperatures, air must flow between the refrigerator and freezer sections. As shown in the illustration below, cool air enters through the bottom of the freezer section and moves up. Most of the air then flows through the freezer section vents and recirculates under the freezer floor. The rest of the air enters the refrigerator section through the top vent.

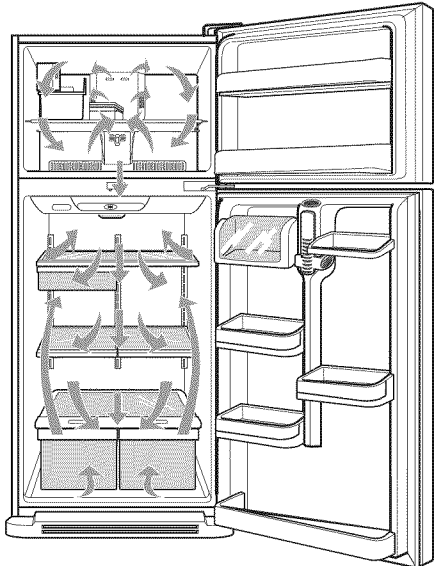

- **Do not block any of these vents** with food packages. If the vents are blocked, airflow will be interrupted and temperature and moisture problems may occur.

IMPORTANT:

Because air circulates between both sections, any odors formed in one section will transfer to the other. You must thoroughly clean both sections to eliminate odors. To prevent odor transfer and drying out food, wrap or cover foods tightly. (See the Food Storage Guide section for details.)

Note: If you close the refrigerator door forcefully, the freezer door may open and close again due to pressure from internal air flow.

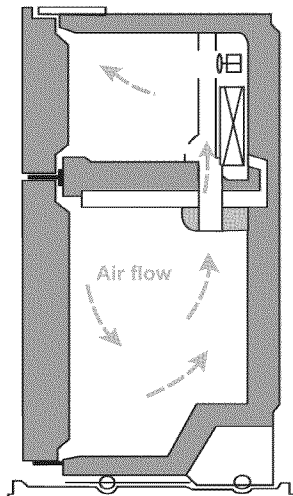

NEXT

1. Clean your refrigerator thoroughly and wipe off all dust accumulated during shipping.
2. Install accessories such as ice cube bin, drawers, shelves, etc., in their proper places. They are packed together to prevent possible damage during shipment.
3. Let your refrigerator run for at least 2 or 3 hours before putting food in it. Check the flow of cold air in the freezer compartment to ensure proper cooling. Your refrigerator is now ready for use.

SETTING THE CONTROLS

Your refrigerator has two controls to regulate temperature, one in the freezer and one in the refrigerator.

REFRIGERATOR CONTROL

Initially set the Refrigerator Control on the middle setting, number 3. To do so, push the temperature adjust button until the number 3 LED light is lit up. Leave the refrigerator at this setting for 24 hours to reach correct temperature. After 24 hours, adjust the compartment temperature as desired. The higher the number, the colder the refrigerator compartment will become. Always wait 24 hours before adjusting temperature. If you go past the desired number, keep pushing the temperature adjust button until your desired number is lit up.

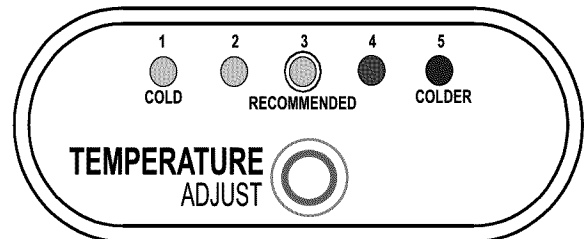

FREEZER CONTROL

The freezer control should come from the factory set on the middle setting, number 2. Wait 24 hours before adjusting the temperature of the freezer compartment up or down. Turn the dial to set freezer temperature as desired. **ALWAYS** wait 24 hours after any adjustment for unit to reach desired temperature.

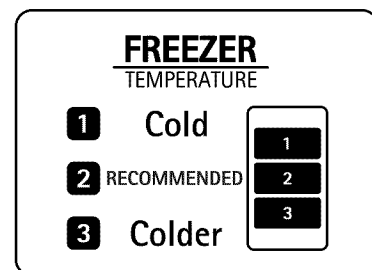

USING YOUR REFRIGERATOR

ADJUSTING CONTROL SETTINGS

Give the refrigerator time to cool down completely before making final adjustments. It is best to wait 24 hours before doing this. The recommended settings mentioned in **SETTING THE CONTROLS** section should be correct for normal household refrigerator use. The controls are set correctly when milk or juice is as cold as you like and when ice cream is firm.

The refrigerator control functions as the thermostat for the entire appliance (refrigerator and freezer sections). The higher the number setting, the longer the compressor will run to keep the temperature colder. The freezer control adjusts the cold air flow from the freezer to the refrigerator. Setting the freezer control to a lower temperature keeps more cold air in the freezer compartment to make it colder.

If you need to adjust temperatures in the refrigerator or freezer, start by adjusting the refrigerator. Then wait 24 hours before checking the freezer temperature. If it is too warm or too cold, then adjust the freezer control.

Use the settings listed in the chart below as a guide. **Always remember to wait at least 24 hours between adjustments.**

CONDITION/ REASON:	RECOMMENDED ADJUSTMENT:
<ul style="list-style-type: none"> ■ REFRIGERATOR section too warm – Door opened often – Large amount of food added – Room temperature very warm 	Turn REFRIGERATOR control to next highest number, wait 24 hours, then re-check
<ul style="list-style-type: none"> ■ FREEZER section too warm/ice not made fast enough – Door opened often – Large amount of food added – Very cold room temperature (Compressor doesn't cycle often enough) – Heavy ice usage – Air vents blocked by items 	Turn FREEZER control to next highest number, wait 24 hours, then re-check Move items out of airstream
<ul style="list-style-type: none"> ■ REFRIGERATOR section too cold – Controls not set correctly for your conditions 	Set REFRIGERATOR control to next lower number, wait 24 hours, then re-check
<ul style="list-style-type: none"> ■ FREEZER section too cold – Controls not set correctly for your conditions 	Set FREEZER control to next lower number, wait 24 hours, then re-check

FOOD STORAGE GUIDE

Wrap or store food in the refrigerator in airtight and moisture-proof material unless otherwise noted. This prevents food odor and taste transfer throughout the refrigerator. For dated products, check date code to ensure freshness.

Items	How to
Butter or margarine	▶ Keep opened butter in a covered dish or closed compartment. When storing an extra supply, wrap in freezer packaging and freeze.
Cheese	▶ Store in the original wrapping until you are ready to use. Once opened, rewrap tightly in plastic wrap or aluminum foil.
Milk	▶ Wipe milk cartons. For best storage, place milk on interior shelf, not on door shelf.
Eggs	▶ Store in original carton or Egg Box (on certain models) on interior shelf, not on door shelf.
Fruit	▶ Wash, let dry, and store in refrigerator in plastic bags or in the crisper. Do not wash or hull berries until you are ready to use them. Sort and keep berries in their original container in a crisper, or store in a loosely closed paper bag on a refrigerator shelf.
Leafy vegetables	▶ Remove store wrapping and trim or tear off bruised and discolored areas. Wash in cold water and drain. Place in plastic bag or plastic container and store in crisper.
Vegetables with skins (carrots, peppers)	▶ Place in plastic bags or plastic container and store in crisper.
Fish	▶ Use fresh fish and shellfish the same day purchased.
Leftovers	▶ Cover leftovers with plastic wrap or aluminum foil. Plastic containers with tight lids can also be used.

STORING FROZEN FOOD

NOTE: For further information about preparing food for freezing or food storage times, check a freezer guide or a reliable cookbook.

Packaging

Successful freezing depends on correct packaging. Close and seal packages so no air or moisture can pass in or out. If it does, you could have food odor and taste transferred throughout the refrigerator and freezer, and food in freezer package could dry out.

Packaging recommendations:

- Rigid plastic containers with tight-fitting lids
- Straight-sided canning/freezing jars
- Heavy-duty aluminum foil
- Plastic-coated paper
- Non-permeable plastic wraps
- Specified freezer-grade self-sealing plastic bags

Follow package or container instructions for proper freezing methods.

Do not use

- Bread wrappers
- Non-polyethylene plastic containers
- Containers without tight lids
- Wax paper or wax-coated freezer wrap
- Thin, semi-permeable wrap

⚠ CAUTION: Do not keep beverage cans or plastic beverage containers in the freezer compartment. They may break if they freeze.

Freezing

Your freezer will not quick-freeze any large quantity of food. Do not put more unfrozen food into the freezer than will freeze within 24 hours (no more than 2 to 3 lbs of food per cubic foot of freezer space). Leave enough space in the freezer for air to circulate around packages. Be careful to leave enough room at the front so the door can close tightly.

Storage times will vary according to the quality and type of food, the type of packaging or wrap used (airtight and moisture-proof) and the storage temperature. Ice crystals inside a sealed package are normal. This simply means that moisture in the food and air inside the package has condensed, creating ice crystals.

NOTE: Allow hot foods to cool at room temperature for 30 minutes, then package and freeze. Cooling hot foods before freezing saves energy.

REFRIGERATOR SHELVES

The shelves in your refrigerator are adjustable to meet your individual storage needs. All the shelves in this unit are glass.

Storing similar food items together in your refrigerator and adjusting the shelves to fit different heights of items will make finding the exact item you want easier; it will also reduce the amount of time the refrigerator door is open, saving energy.

IMPORTANT: Do not clean glass shelves with warm water when they are cold. Shelves may break if exposed to sudden temperature changes or impact, such as bumping. For your protection, glass shelves are made with tempered glass, which will shatter into small pebble-sized pieces.

NOTE: Glass shelves are heavy. Use special care when removing them to avoid dropping them.

Adjustable Shelves

Remove shelves from the shipping position and replace shelves in the position you want.

- **To remove a shelf**—Tilt the front of the shelf upward and pull it out.
- **To replace a shelf**—Tilt the front of the shelf up and place the shelf hooks into metal slots at desired position. Then lower the front of the shelf to secure the hooks in the slots.

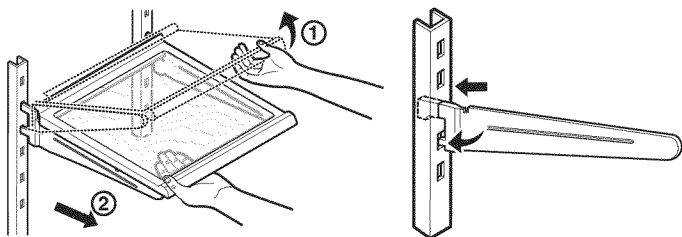

NOTE: Make sure that shelves are level from one side to the other. Failure to do so may result in the shelf falling or spilling food.

Slide Out Shelves (On Some Models)

You can slide some glass shelves in and out of your refrigerator as follows.

- **To slide the shelf out**, carefully pull front of shelf toward you.
- **To slide shelf in**, push shelf in until it stops.

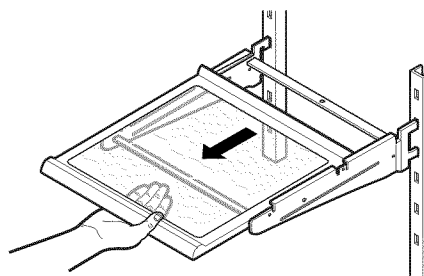

SNACK DRAWER (On Some Models)

To remove the snack drawer: Hold drawer by handle, pull forward to drawer stop, lift up and pull out.

To replace snack drawer, slide back in fully past the drawer stop.

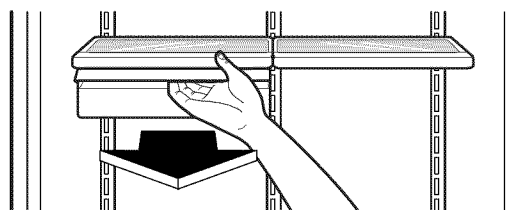

USING YOUR REFRIGERATOR



CRISPER AND CRISPER COVER

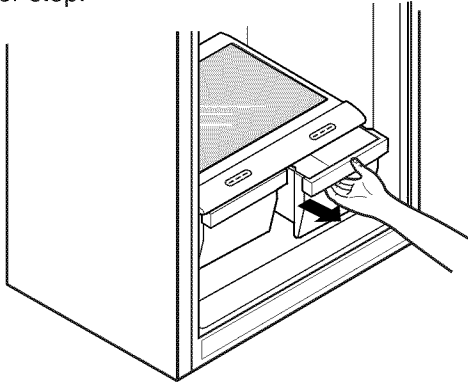

To remove the crisper:

1. Pull crisper drawer out to drawer stop.
2. Lift the drawer up and toward you to pull out and remove.
3. To replace crisper, slide back in fully past the drawer stop.



CRISPER HUMIDITY CONTROL

You can control the amount of humidity in the moisture-sealed crispers. Adjust the control to any setting between  and .

-  lets moist air out of the crisper for best storage of fruits.
-  keeps moist air in the crisper for best storage of fresh, leafy vegetables.

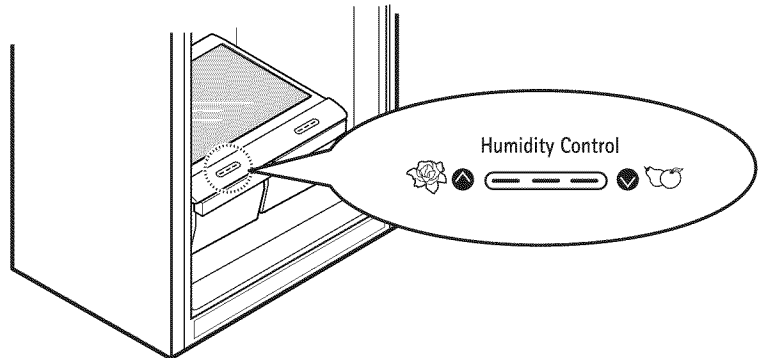

To control the humidity in the crisper compartments, move the slide above each crisper up (more moisture) or down (less moisture)

To remove crisper glass:

1. Remove crisper drawers.
2. To remove glass above crispers, reach in under the glass and lift up.
3. Pull glass up and out.

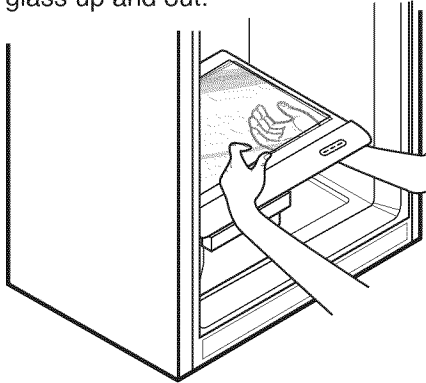

SNAP-ON DOOR RACKS

The door racks may be removed for easier cleaning. Door racks are in both the refrigerator and the freezer. The door racks are force-fitted with tabs and slots.

Snap-On Door Racks

To remove door racks:

1. Remove all items from the door rack.
2. Push sides of rack together while lifting up. Rack will lift out.

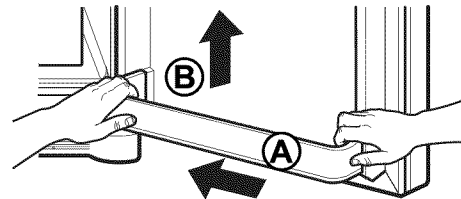

To remove the crisper cover:

1. Remove both crisper drawers.
2. While holding the center crisper cover support in place, pull the cover up and out.

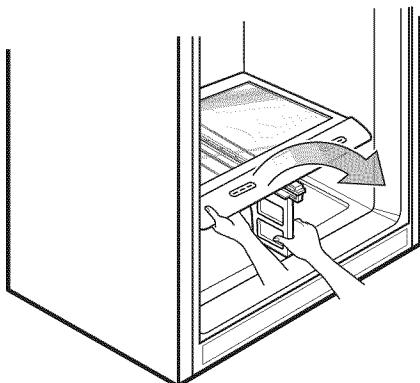

To replace the racks:

1. Hold door rack ends with both hands tilted slightly downward and push together slightly while fitting tabs on rack into slots in door. Force-fit into place.

USING YOUR REFRIGERATOR

DOOR BINS

The door bins are removable for easy cleaning and adjusting. They have slots in the sides which fit into support slots placed at intervals on refrigerator door.

1. To remove a bin, lift the bin up until it clears the support slots and lift out.
2. To replace a bin, push into door and down onto a set of support slots at the desired level.

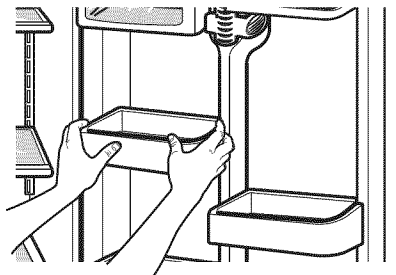

ICE TRAY (On Some Models)

Icemaking

- Pour water to the level indicated in the picture. Do not overfill with water, or ice cubes will be difficult to remove.
- For quick freeze, adjust the freezer dial to 3.

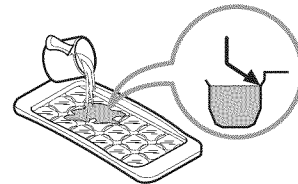

To remove ice cubes, twist the tray.

- Do not bend the ice tray. Doing so may result in damage to the tray.
- To remove ice cubes easily, pour water on the back of the tray or soak it in water before removing ice cubes.

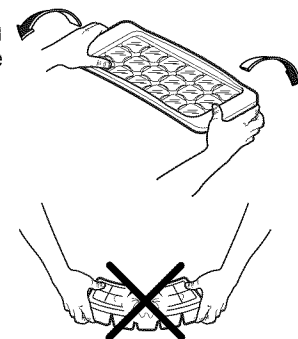

DAIRY BIN, CAN RACK (On Some Models)

The dairy bin/can rack can be relocated to another position.

1. To remove the dairy bin / can rack simply lift up and pull out.
2. To replace the bin, slide it in above the desired support slots and push down until it stops.

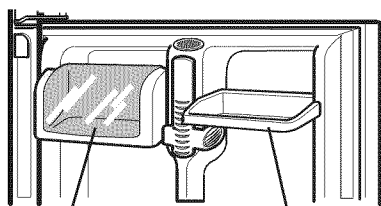

Dairy Bin

Can Rack

CARE AND CLEANING

⚠ WARNING



Explosion Hazard

Use non-flammable cleaner.

Failure to do so can result in death, explosion or fire.

Both the refrigerator and freezer sections defrost automatically. However, clean both sections about once a month to prevent odors. Wipe up spills immediately.

GENERAL CLEANING TIPS

- Unplug refrigerator or disconnect power.
- Remove all removable parts, such as shelves, crispers, etc.
- To clean shelves, bins and other removable parts, use a clean sponge or soft cloth and a mild detergent in warm water. Do not use abrasive or harsh cleaners.
- Hand wash, rinse and dry all surfaces thoroughly.
- When finished cleaning, don't forget to plug in or reconnect power.

OUTSIDE

Waxing external painted metal surfaces helps provide rust protection. Do not wax plastic parts. Wax painted metal surfaces at least twice a year using appliance wax (or auto paste wax). Apply wax with a clean soft cloth.

Do Not use wax on stainless steel exteriors. Use a product specially designed for polishing stainless steel appliances, or clean with a soft cloth or clean sponge and a mild detergent dissolved in warm water. Dry thoroughly with a soft cloth.

NOTE: Avoid door surface contact with chemical products that contain Phosphate or Chlorine.

INSIDE WALLS (allow freezer to warm up so cloth won't stick)

To help remove odors, you can wash the inside of the refrigerator and freezer with a mixture of baking soda and warm water. Mix 2 tablespoons baking soda to 1 quart of water (26 g soda to 1 liter water.) Be sure the baking soda completely dissolves so it does not scratch the surfaces of the refrigerator.

DOOR LINERS AND GASKETS

Do not use cleaning waxes, concentrated detergents, bleaches or cleaners containing petroleum on plastic parts. Use a clean sponge or soft cloth and a mild detergent in warm water. Wash, rinse and dry all surfaces thoroughly.

PLASTIC PARTS (covers and panels)

Do not use paper towels, window sprays, abrasive cleansers or flammable fluids. These can scratch or damage the material. Use a clean sponge or soft cloth and a mild detergent in warm water. Wash, rinse and dry all surfaces thoroughly.

BACK COVER

⚠ WARNING

ELECTRICAL SHOCK HAZARD

Before you begin, either unplug the refrigerator or turn off power at the circuit breaker or fuse box. Failure to do so could result in death or serious injury.

NOTE: Back cover should only be removed by a qualified technician.

Clean the vents on the back cover. Use a vacuum cleaner with the brush attachment, at least twice a year to keep your refrigerator working efficiently.

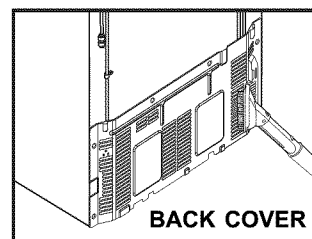

LIGHT BULB REPLACEMENT

⚠ WARNING

Electrical Shock Hazard

Before replacing a burned-out light bulb, either unplug the refrigerator or turn off power at the circuit breaker or fuse box.

NOTE: Not all appliance bulbs will fit your refrigerator. Be sure to replace the bulb with one of 60 watts and the same size and shape.

CARE AND CLEANING

To change the refrigerator light:

1. Unplug the power cord from the outlet.
2. Remove refrigerator shelves.
3. Light shield is force fitted and has plastic tabs on each side and a tab in the front. Release the tabs on each side of light shield and push shield toward rear of refrigerator and remove.
4. Turn the bulb counterclockwise and remove.
5. Replace a burned-out light bulb with a new 40 watt bulb, turning it clockwise.
6. To replace light shield, position front tab into slot and carefully force-fit side tabs into slots.
7. Replace the refrigerator shelves.
8. Plug the power cord into the outlet.

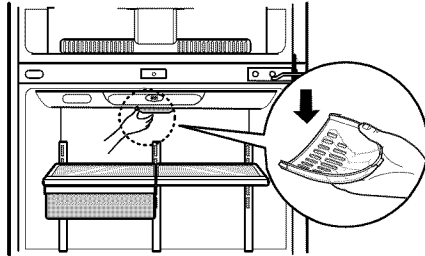

POWER INTERRUPTIONS

1. If the power will be out for 24 hours or less, keep all refrigerator doors closed to help foods stay cold and frozen.
2. If the power will be out for more than 24 hours:
 - a) Remove all frozen food and store it in a frozen food locker.**OR**
 - b) Place 2 lbs. (ca 1kg) of dry ice in the freezer for every cubic foot (28 L) of freezer space. This will keep the food frozen for two to four days. While handling dry ice, wear gloves to protect your hands from frostbite.

⚠ WARNING

Suffocation Hazard

When using dry ice, provide adequate ventilation. Dry ice is frozen carbon dioxide (CO_2). When it vaporizes, it can displace oxygen, causing dizziness, light-headedness, unconsciousness and death by suffocation. Open a window and do not breathe the vapors.

OR

- c) If neither a food locker nor dry ice is available, consume or dispose of food at once.

REMEMBER: In a power failure, a full freezer stays cold longer than a partially filled one. A freezer full of meat stays cold longer than a freezer full of baked goods. If you see that food contains ice crystals, it may be safely refrozen, although the quality and flavor may be affected. If the condition of the food is poor, or if you feel it is unsafe, dispose of it.

⚠ WARNING

• **DO NOT** refreeze frozen foods which have thawed completely. The United States Department of Agriculture in Home and Garden Bulletin No. 69 says:

... You may safely refreeze frozen foods that have thawed if they still contain ice crystals or if they are still cold—below 4°C.

... Thawed ground meats, poultry or fish that have any off-odor or off-color should not be refrozen and should not be eaten. Thawed ice cream should be discarded. If the odor or color of any food is poor or questionable, dispose of it. The food may be dangerous to eat.

Even partial thawing and refreezing reduces the eating quality of foods, particularly fruits, vegetables and prepared foods. The eating quality of red meats is affected less than that of many other foods. Use refrozen foods as soon as possible to save as much of their quality as you can.

WHEN YOU GO ON VACATION

If you choose to leave the refrigerator on while you are away, follow these steps to prepare your refrigerator before you leave.

1. Use up any perishables and freeze other items.
2. Empty the ice bin.
3. Turn off the icemaker. **NOTE:** If the ambient temperature will drop below freezing, have a qualified service technician drain the water supply system (on some models) to prevent serious property damage due to possible flooding from ruptured water lines or connections.

If you choose to turn the refrigerator off before you leave, follow these steps.

1. Remove all food from the refrigerator and empty ice bin.
2. Unplug refrigerator.
3. Clean refrigerator, wipe, and dry well.
4. Tape rubber or wood blocks to the tops of both doors to prop them open far enough for air to get in. This stops odor and mold from building up.

WHEN YOU MOVE

When you are moving your refrigerator to a new home, follow these steps to prepare it for the move.

1. Remove all food from the refrigerator and pack all frozen food in dry ice.
2. Unplug refrigerator.
3. Clean refrigerator, wipe, and dry well.
4. Empty water from the defrost pan.
5. Clean, wipe and dry thoroughly.
6. Take out all removable parts, wrap them well and tape them together so they don't shift and rattle during the move. Refer to sections in Using your Refrigerator for removal instructions.
7. Depending on the model, raise the front of the refrigerator so it rolls more easily OR screw in the leveling legs all the way so they don't scrape the floor. See the **LEVELING AND DOOR CLOSING** section.
8. Tape the doors shut and tape the power cord to the refrigerator cabinet.

When you get to your new home, put everything back and refer to the **REFRIGERATION INSTALLATION** section for setup instructions.

ABOUT THE AUTOMATIC ICE MAKER

⚠ WARNING

Personal Injury Hazard

Avoid contact with the moving parts of the ejector mechanism, or with the heating element that releases the cubes. **DO NOT** place fingers or hands on the automatic icemaking mechanism while the refrigerator is plugged in.

The icemaker will begin to operate when it lowers to freezing temperature.

NOTE: Automatic Ice Maker feature is included only in certain models. Other models are Ice Maker ready. Please check your product specifications.

OPERATION INSTRUCTIONS

A newly-installed refrigerator may take 12 to 24 hours to begin making ice.

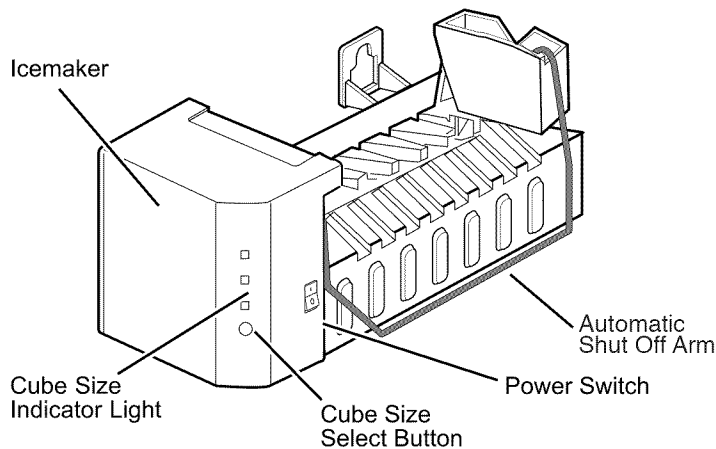

The icemaker will produce eight cubes per cycle—approximately 100–130 cubes in a 24-hour period, depending on freezer compartment temperature, room temperature, number of door openings and other operating conditions.

If the refrigerator is used before the water connection is made to the icemaker, set the icemaker's power switch to **O (off)**.

When the refrigerator has been connected to the water supply, set the power switch to **I (on)**.

The icemaker will begin to operate when it lowers to freezing temperature. A newly-installed refrigerator may take 12 to 24 hours to begin making ice cubes.

Throw away the first few batches of ice to allow the water line to clear.

Be sure nothing interferes with the sweep of the Automatic Shut Off Arm.

When the bin fills to the level of the Automatic Shut Off Arm, the icemaker will stop producing ice.

It is normal for several cubes to be stuck together.

If ice is not used frequently, old ice cubes will become cloudy, taste stale, and shrink.

NOTE: If the cube size is smaller or larger than you expected, you can regulate the size with the cube size button.

Every time you press the cube size button, the indicator moves up one light. The higher the light position, the larger the cubes will be. Pressing at highest position returns indicator to lowest position.

WHEN YOU SHOULD SET THE ICEMAKER POWER SWITCH TO O (OFF)

- When the water supply will be shut off for several hours.
- When the ice storage bin is removed for more than a minute or two.
- When the refrigerator will not be used for several days.

NORMAL SOUNDS YOU MAY HEAR

- The icemaker water valve will buzz as the icemaker fills with water. If the power switch is in the **I (on)** position, it will buzz even if it has not yet been hooked up to water. To stop the buzzing, move the power switch to **O (off)**.

NOTE: Keeping the power switch in the **I (on)** position before the water line is connected can damage the icemaker.

- You will hear the sound of cubes dropping into the bin and water running in the pipes as the icemaker refills.

CONNECTING THE WATERLINE

NOTE: Water line installation is needed when the Automatic Icemaker and/or Water Dispenser features are available on your product.

BEFORE YOU BEGIN

This water line installation is not warranted by the refrigerator or icemaker manufacturer. Follow these instructions carefully to minimize the risk of expensive water damage.

Water hammer (water banging in the pipes) in house plumbing can cause damage to refrigerator parts and lead to water leakage or flooding. Call a qualified plumber to correct water hammer before installing the water supply line to the refrigerator.

To prevent burns and product damage, do not hook up the water line to the hot water line.

If you use your refrigerator before connecting the water line, make sure the icemaker power switch is in the **O (off)** position.

Do not install the icemaker tubing in areas where temperatures fall below freezing.

When using any electrical device (such as a power drill) during installation, be sure the device is double-insulated or grounded in a manner to prevent the hazard of electric shock, or is battery-powered.

All installations must be in accordance with local plumbing code requirements.

NOTE: Wear eye protection.

- If a **reverse osmosis water filtration system** is connected to your cold water supply, This water line installation is not warranted by the refrigerator or icemaker manufacturer. Follow next instructions carefully to minimize the risk of expensive water damage.
- If a **reverse osmosis water filtration system** is connected to your cold water supply, the water pressure to the reverse osmosis system needs to be a minimum of 40 to 60 PSI or 0.27 MPa to 0.41MPa (2.8 kg-f/cm² ~ 4.2 kg-f/cm², less than 2 ~ 3 seconds to fill a cup of 7 oz capacity [0.2 liters]).
If the water pressure from the reverse osmosis system is less than 21 PSI or 0.14 MPa (1.5 kg-f/cm², more than 4 seconds to fill a cup of 7 oz capacity [0.2 liters]).
 - Check to see whether the sediment filter in the reverse osmosis system is blocked. Replace the filter if necessary.
 - Allow the storage tank on the reverse osmosis system to refill after heavy usage.
 - If the issue about water pressure from reverse osmosis remains, call a licensed, qualified plumber.

WHAT YOU WILL NEED

- **Copper Tubing**, 1/4" outer diameter to connect the refrigerator to the water supply. Be sure both ends of the tubing are cut square.

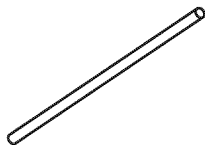

To determine how much tubing you need: measure the distance from the water valve on the back of the refrigerator to the water supply pipe. Then add 8 feet (2.4 m). Be sure there is sufficient extra tubing (about 8 feet [2.4 m] coiled into 3 turns of about 10 [25 cm] diameter) to allow the refrigerator to move out from the wall after installation.

Be sure that the kit you select allows at least 8 feet (2.4 m) as described above.

- **A cold water supply**. The water pressure must be between 20 and 120 PSI or 0.137 and 0.82 MPa on models without a water filter and between 40 and 120 PSI or 0.275 and 0.82 MPa on models with a water filter.

- **Power drill.**
- **1/2" or adjustable wrench .**
- **Straight- and Phillips-blade screwdriver**

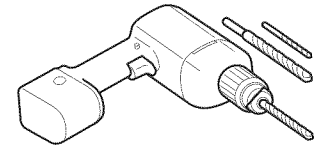

- **Two 1/4" outer diameter compression nuts and 2 ferrules (sleeves)** to connect the copper tubing to the shutoff valve and the refrigerator water valve.

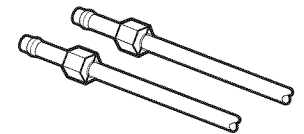

- If your existing copper water line has a flared fitting at the end, you will need an **adapter** (available at plumbing supply stores) to connect the water line to the refrigerator OR you can cut off the flared fitting with a tube cutter and then use a compression fitting.

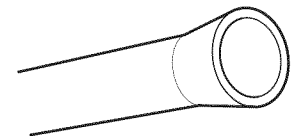

- **Shut off valve to connect to the cold water line.** The shutoff valve should have a water inlet with a minimum inside diameter of 5/32" at the point of connection to the COLD WATER LINE. Saddle-type shutoff valves are included in many water supply kits. Before purchasing, make sure a saddle-type valve complies with your local plumbing codes.

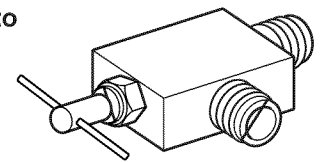

INSTALLATION INSTRUCTIONS

Install the shutoff valve on the nearest frequently used drinking water line.

1. SHUT OFF THE MAIN WATER SUPPLY

Turn on the nearest faucet to relieve the pressure on the line.

CONNECTING THE WATERLINE

INSTALLATION INSTRUCTIONS (CONTINUED)

2. CHOOSE THE VALVE LOCATION

Choose a location for the valve that is easily accessible. It is best to connect into the side of a vertical water pipe. When it is necessary to connect into a horizontal water pipe, make the connection to the top or side, rather than at the bottom, to avoid drawing off any sediment from the water pipe.

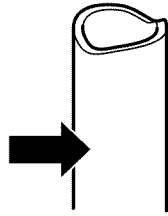

3. DRILL THE HOLE FOR THE VALVE

Drill a 1/4" hole in the water pipe (even if using a self-piercing valve) using a sharp bit. Remove any burrs resulting from drilling the hole in the pipe. Take care not to allow water to drain into the drill. Failure to drill a 1/4" hole may result in reduced ice production or smaller cubes.

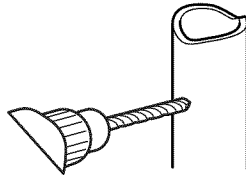

4. FASTEN THE SHUT OFF VALVE

Fasten the shutoff valve to the cold water pipe with the pipe clamp.

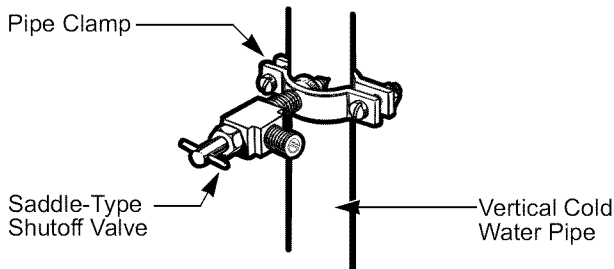

NOTE: Commonwealth of Massachusetts Plumbing Codes 248CMR shall be adhered to. Saddle valves are illegal and use is not permitted in Massachusetts. Consult with your licensed plumber.

5. TIGHTEN THE PIPE CLAMP

Tighten the clamp screws until the sealing washer begins to swell.

NOTE: Do not overtighten or you may crush the tubing.

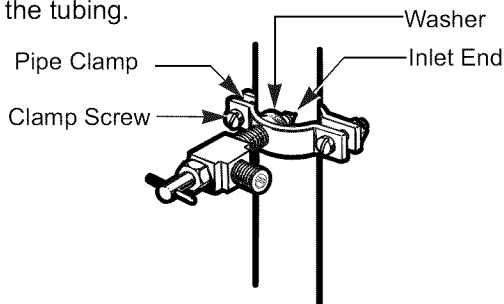

6. ROUTE THE TUBING

Route the tubing between the cold water line and the refrigerator.

Route the tubing through a hole drilled in the wall or floor (behind the refrigerator or adjacent base cabinet) as close to the wall as possible.

NOTE: Be sure there is sufficient extra tubing (about 8 feet coiled into 3 turns of about 10 diameter) to allow the refrigerator to move out from the wall after installation.

7. CONNECT THE TUBING TO THE VALVE

Place the compression nut and ferrule (sleeve) for copper tubing onto the end of the tubing and connect it to the shutoff valve. Make sure the tubing is fully inserted into the valve. Tighten the compression nut securely.

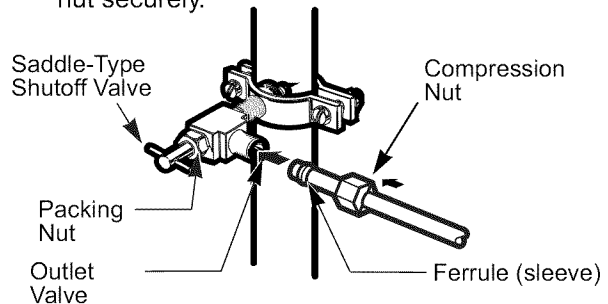

NOTE: Commonwealth of Massachusetts Plumbing Codes 248CMR shall be adhered to. Saddle valves are illegal and use is not permitted in Massachusetts. Consult with your licensed plumber.

8. FLUSH OUT THE TUBING

Turn the main water supply on and flush out the tubing until the water is clear.

Shut the water off at the water valve after about one quart of water has been flushed through the tubing.

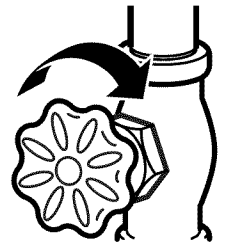

CONNECTING THE WATER LINE

9. CONNECT THE TUBING TO THE REFRIGERATOR

NOTES:

- Before making the connection to the refrigerator, be sure the refrigerator power cord is not plugged into the wall outlet.
- If your refrigerator does not have a water filter, we recommend installing one if your water supply has sand or particles that could clog the screen of the refrigerator's water valve. Install the filter in the water line near the refrigerator.

IMPORTANT: Do not use old, worn or used waterlines, only use new for a better use and service. Connect only to the supply of drinking water for your safety and health.

1. Remove the plastic flexible cap from the water valve.
2. Place the compression nut and ferrule (sleeve) onto the end of the tubing as shown.
3. Insert the end of the copper tubing into the connection as far as possible. While holding the tubing, tighten the fitting.

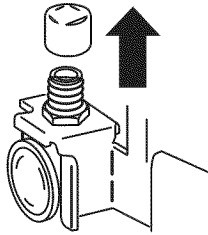

⚠ CAUTION: Check to see if leaks occur at water line connections.

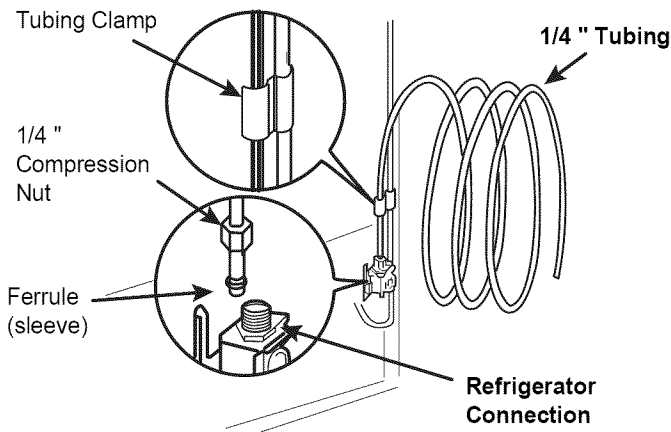

⚠ CAUTION: Check to see if water dripping occurs at water line connections.

10. TURN THE WATER ON AT THE SHUTOFF VALVE

Tighten any connections that leak.

Reattach the compressor compartment access cover.

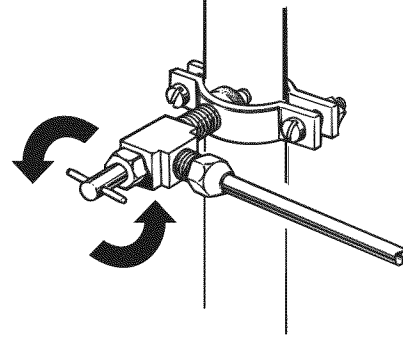

11. PLUG IN THE REFRIGERATOR

Arrange the coil of tubing so that it does not vibrate against the back of the refrigerator or against the wall. Push the refrigerator back to the wall.

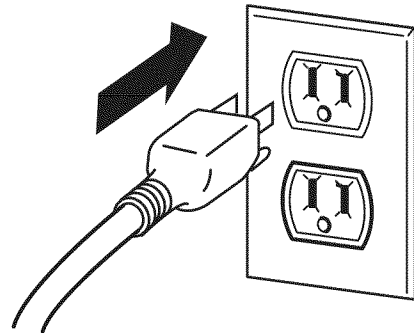

12. START THE ICEMAKER

Set the icemaker power switch to the ON position. The icemaker will not begin to operate until it reaches its operating temperature of 15 °F (-9 °C) or below. It will then begin operation automatically if the icemaker power switch is in the I (on) position.

TROUBLESHOOTING GUIDE

UNDERSTANDING SOUNDS YOU MAY HEAR

Your new refrigerator may make sounds that your old one didn't make. Because the sounds are new to you, you might be concerned about them. Most of the new sounds are normal. Hard surfaces, like the floor, walls and cabinets, can make the sounds seem louder than they actually are. The following describes the kinds of sounds and what may be making them.

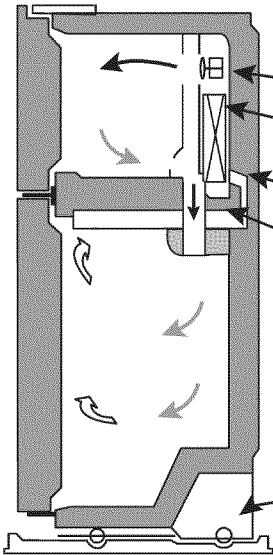

- The defrost timer will click when the automatic defrost cycle begins and ends. The thermostat control (or refrigerator control, depending on the model) will also click when cycling on and off.
- Rattling noises may come from the flow of refrigerant, the water line or items stored on top of the refrigerator.
- Your refrigerator is designed to run more efficiently to keep your food items at the desired temperature. The high efficiency compressor may cause your new refrigerator to run longer than your old one, but it will take less energy to run. You may hear a pulsating or high-pitched sound.
- You may hear the evaporator fan motor circulating the air through the refrigerator and freezer compartments.
- As each cycle ends, you may hear a gurgling sound due to the refrigerant flowing in your refrigerator.
- Contraction and expansion of the inside walls may cause a popping noise.
- Water dripping on the defrost heater during a defrost cycle may cause a sizzling sound.
- You may hear air being forced over the condenser by the condenser fan.
- You may hear water running into the drain pan during the defrost cycle.

REFRIGERATOR DOES NOT OPERATE

Check if...

Then...

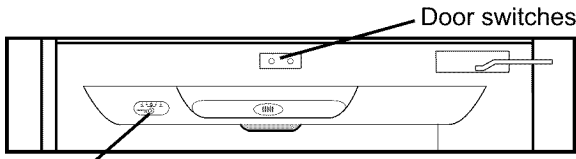
The power supply cord is unplugged.	Firmly plug the cord into a live outlet with proper voltage.
A household fuse has blown or circuit breaker tripped.	Replace the fuse or reset the circuit breaker.
The control panel lights are blinking sequentially (1-2-3-4-5):	<p>The refrigerator control has been put into the store Demo (Demonstration) Mode.</p> <p>To exit the Demo Mode:</p> <ol style="list-style-type: none"> 1. Open both the refrigerator and freezer doors. 2. Push in both door switches and at the same time press and hold the Temperature Adjust button for 5 seconds. <div style="text-align: center;">  <p>Door switches</p> <p>Temp. Adjust Button</p> </div>
Refrigerator is in the defrost cycle.	Wait about 30 minutes for defrost cycle to end.

VIBRATION OR RATTLING NOISE

Check if...

Then...

The refrigerator is not resting solidly on the floor.	Floor is weak or uneven or leveling legs need adjusting. See LEVELING AND DOOR CLOSING section .
---	---

TROUBLESHOOTING GUIDE

LIGHTS DO NOT WORK

Check if...	Then...
The power supply cord is unplugged.	Firmly plug the cord into a live outlet with proper voltage.
Light bulb is loose in the socket.	Either unplug the refrigerator or turn off power at the circuit breaker or fuse box. Gently remove the bulb and reinsert. Then plug in refrigerator and reset the refrigerator control.
Light bulb has burned out.	Either unplug the refrigerator or turn off power at the circuit breaker or fuse box. Replace the old bulb with a new 60 watts appliance bulb with the same size and shape available at your local hardware store. (See the LIGHT BULB REPLACEMENT section.)

COMPRESSOR MOTOR SEEMS TO RUN TOO MUCH

Check if...	Then...
The refrigerator that was replaced was an older model.	Modern refrigerators with more storage space require more operating time.
The room temperature is hotter than normal.	The motor will run longer under warm conditions. At normal room temperatures, expect your motor to run about 40% to 80% of the time. Under warmer conditions, expect it to run even more often.
The door is opened often or a large amount of food has just been added.	Adding food and opening the door warms the refrigerator. It is normal for the refrigerator to run longer in order to cool the refrigerator back down. Adding a large amount of food warms the refrigerator. See the FOOD STORAGE GUIDE section. In order to conserve energy, try to get everything you need out of the refrigerator at once; also keep food organized so it is easy to find and close the door as soon as the food is removed.
The refrigerator was recently plugged in and the refrigerator control was set correctly.	The refrigerator will take up to 24 hours to cool completely.
The refrigerator control is not set correctly for the surrounding conditions.	See the ADJUSTING CONTROL SETTINGS section
The doors are not closed completely.	Push the doors firmly shut. If they will not shut all the way, see "Doors will not close completely" below.
The condenser coils are dirty.	This prevents air transfer and makes the motor work harder. Clean the condenser coils. Refer to the CARE AND CLEANING section.

DOORS WILL NOT CLOSE COMPLETELY

Check if...	Then...
The refrigerator is not level.	See the REFRIGERATOR INSTALLATION, LEVELING AND DOOR ALIGNMENT section to level refrigerator.
Food packages are blocking the door open.	Rearrange food containers to clear door and door shelves.
The ice bin, crisper cover, pans, shelves, door bins or baskets are out of position.	Push bins all the way in and put crisper cover, pans, shelves and baskets into their correct positions. See the USING YOUR REFRIGERATOR section
The gaskets are sticking.	Clean gaskets and the surface that they touch. Rub a thin coat of paraffin wax on the gaskets after cleaning.
The refrigerator wobbles or seems unstable.	Level the refrigerator. Refer to the LEVELING AND DOOR CLOSING section
The doors were removed during product installation and not properly replaced.	Remove and replace the doors according to the REMOVING AND REPLACING DOORS or REVERSING DOORS section or call a Sears or other qualified service technician.

TROUBLESHOOTING GUIDE

FROST OR ICE CRYSTALS ON FROZEN FOOD

Check if...	Then...
The door is not closing properly.	See "Doors will not close completely" above.
The door is opened often.	When the door is opened, warm, humid air is allowed in the freezer resulting in frost.

ICE HAS OFF-TASTE OR ODOR

Check if...	Then...
The icemaker was recently installed.	Discard first few batches of ice to avoid discolored or off-flavored ice.
The ice has been stored for too long.	Throw away old ice and make new supply.
The food has not been wrapped tightly in either compartment.	Rewrap foods since odors may migrate to the ice if food is not wrapped properly.
The water supply contains minerals such as sulfur.	A filter may need to be installed to eliminate taste and odor problems.
The interior of refrigerator needs cleaning.	See CARE AND CLEANING section.
Ice storage bin needs cleaning.	Empty and wash bin. Discard old cubes.

THERE IS WATER IN THE DEFROST DRAIN PAN

Check if...	Then...
The refrigerator is defrosting.	The water will evaporate. It is normal for water to drip into the defrost pan.
It is more humid than normal.	Expect that the water in the defrost pan will take longer to evaporate. This is normal when it is hot or humid.

THE REFRIGERATOR SEEMS TO MAKE TOO MUCH NOISE

Check if...	Then...
The sounds may be normal for your refrigerator.	Refer to the UNDERSTANDING SOUNDS YOU MAY HEAR section

THE ICEMAKER IS NOT PRODUCING ICE OR ICE CUBES ARE FREEZING TOO SLOWLY

Check if...	Then...
The freezer temperature is cold enough to produce ice.	Wait 24 hours after hook-up for ice production. See the SETTING THE CONTROLS section.
Door left open.	Check to see if something is holding door open.

CUBES PRODUCED BY ICEMAKER ARE TOO SMALL

Check if...	Then...
Smaller cube size level is selected.	Select larger cube size using cube size selector.
Water shutoff valve connecting refrigerator to water line may be clogged.	Call a plumber to clear the valve.

TROUBLESHOOTING GUIDE

THE DOORS ARE DIFFICULT TO OPEN

Check if...	Then...
The gaskets are dirty or sticky.	Clean gaskets and the surfaces that they touch. Rub a thin coat of paraffin wax on the gaskets following cleaning.
The door is reopened within a short time after having been opened.	When you open the door, warmer air enters the refrigerator. As the warm air cools, it can create a vacuum. If the door is hard to open, wait 5 minutes to allow the air pressure to equalize, then see if it opens more easily.

AUTOMATIC ICEMAKER DOES NOT WORK (Icemaker On Some Models)

Check if...	Then...
Icemaker power switch in the O (off) position.	Move the switch to the I (on) position.
Water supply turned off or not connected.	See the CONNECTING THE WATER LINE section.
Freezer compartment too warm.	Wait 24 hours for the freezer to reach its ideal temperature.
Piled up cubes in the storage bin cause the icemaker to shut off.	Level cubes by hand.

TEMPERATURE IS TOO WARM OR THERE IS INTERIOR MOISTURE BUILDUP

Check if...	Then...
The air vents are blocked. Cold air circulates from the freezer to the fresh food section and back again through air vents in the wall dividing the two sections.	Locate air vents by using your hand to sense airflow and move all packages that block vents and restrict airflow. Refer To ENSURING PROPER AIR CIRCULATION for the location of air vents.
The doors are opened often.	When the door is opened, warm humid air is allowed into the refrigerator. The more the door is opened, the faster the humidity builds up, and the more warm air the refrigerator must cool. In order to keep the refrigerator cool, try to get everything you need out of the refrigerator at once; also, keep food organized so it is easy to find and close the door as soon as the food is removed.
The control is not set correctly for the surrounding conditions.	Refer to the SETTING THE CONTROLS section. Wait 24 hours for temperatures to stabilize or even out. If the temperature is too cold or too warm, move the dial one number at a time.
A large amount of food has just been added to the refrigerator or freezer.	Adding food warms the refrigerator. It can take a few hours for the refrigerator to return to normal temperature.
The food is not packaged correctly.	Wrap food tightly and wipe off damp containers prior to storing in the refrigerator to avoid moisture accumulation. If necessary, repackage food according to the guidelines in the FOOD STORAGE GUIDE section.
The doors are not closing completely.	See “Doors will not close completely” .
The weather is humid.	In humid weather, air carries moisture into refrigerator when doors are opened.
A self-defrost cycle was completed.	It is normal for droplets to form on the back wall after the refrigerator self-defrosts.

Get it fixed, at your home or ours!

Your Home

For expert troubleshooting and home solutions advice:

manage my home

www.managemyhome.com

For repair – **in your home** – of **all** major brand appliances, lawn and garden equipment, or heating and cooling systems, **no matter who made it, no matter who sold it!**

For the replacement parts, accessories and owner's manuals that you need to do-it-yourself.

For Sears professional installation of home appliances and items like garage door openers and water heaters.

1-800-4-MY-HOME[®] Call anytime, day or night
(1-800-469-4663) (U.S.A. and Canada)
www.sears.com www.sears.ca

Our Home

For repair of carry-in items like vacuums, lawn equipment, and electronics, call anytime for the location of the nearest **Sears Parts & Repair Service Center**

1-800-488-1222 (U.S.A.) **1-800-469-4663** (Canada)
www.sears.com www.sears.ca

To purchase a protection agreement on a product serviced by Sears:

1-800-827-6655 (U.S.A.) **1-800-361-6665** (Canada)

Para pedir servicio de reparación a domicilio, y para ordenar piezas:

1-888-SU-HOGAR[®]
(1-888-784-6427)

Au Canada pour service en français:

1-800-LE-FOYER^{MC}
(1-800-533-6937)
www.sears.ca

Sears

© Sears Brands, LLC

® Registered Trademark / ™ Trademark / ™ Service Mark of Sears Brands, LLC

® Marca Registrada / ™ Marca de Fábrica / ™ Marca de Servicio de Sears Brands, LLC

^{MC} Marque de commerce / ^{MD} Marque déposée de Sears Brands, LLC