

Cool Boss™ Portable Evaporative Air Cooler with Swing Louvers

Installation and Operation Manual

Manual P/N: 5900416 – Revision A3 – January 2026

Model CB-19SL

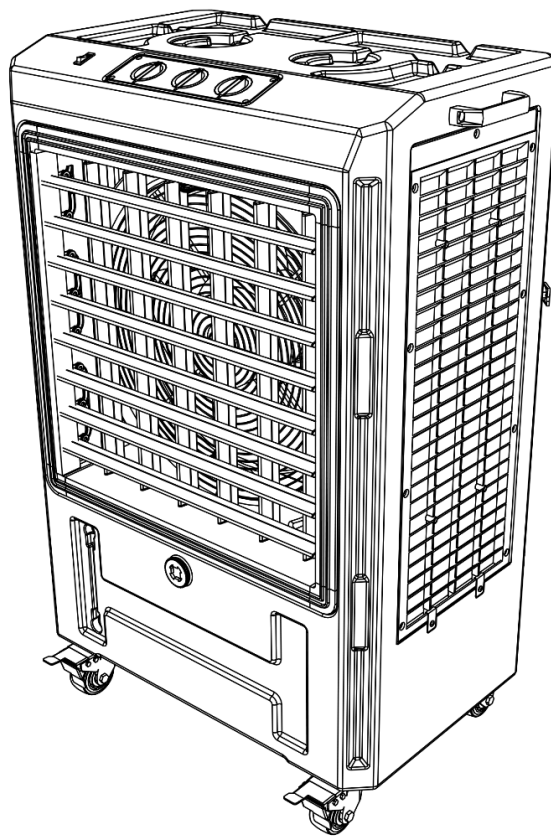

DANGER

IMPORTANT Safety Instructions, save these instructions! **Read the entire contents** of this manual **before** using this product. Failure to follow the instructions and safety precautions in this manual can result in severe injury or death. Make sure all other operators also read this manual. Keep the manual near the product for future reference. By proceeding with setup and operation, you agree that you fully understand the contents of this manual and assume full responsibility for product use.

Manual. Cool Boss™ Portable CB-19SL Evaporative Air Cooler with Swing Louvers, *Installation and Operation Manual*, P/N 5900416, Revision A3, January 2026.

Copyright. Copyright © 2026 by BendPak Inc. All rights reserved. No part of this manual may be reproduced, adapted, translated, or transmitted by any means, electronic or mechanical, for any purpose or in any form, without prior written permission of BendPak Inc.

Trademarks. Cool Boss, the Cool Boss logo, and BendPak are trademarks of BendPak Inc. All other company, product, and service names are used for identification only. All trademarks and registered trademarks mentioned in this manual are the property of their respective owners.

Limitations. Every effort has been made to ensure complete and accurate instructions are included in this manual. However, product updates, revisions, and/or changes may have occurred since this manual was published. BendPak reserves the right to change any information in this manual without incurring any obligation for equipment previously or subsequently sold. BendPak is not responsible for typographical errors in this manual.

Warranty. The Cool Boss warranty is a commitment to the value of this product. Visit coolboss.com/warranty for complete warranty information.



Safety. This product was designed and manufactured with safety in mind. Operator safety depends on proper training and thoughtful operation. Do not set up, operate, maintain, or repair the Cool Boss without reading and understanding this manual and the labels on the unit.

Owner Responsibility. In order to maintain this product properly and to ensure operator safety, it is the responsibility of the product owner to read and follow these instructions:

- Follow all setup, operation, and maintenance instructions.
- Make sure product setup conforms to all applicable local, state, and federal codes, rules, and regulations, such as state and federal OSHA regulations and electrical codes.
- Read and follow all safety instructions. Keep them readily available for operators.
- Make sure all operators are properly trained, know how to safely operate the unit, and are properly supervised.
- Do not operate the product until it is certain that all parts are in place and operating correctly.
- Carefully inspect the product on a regular basis and perform all maintenance as required.
- Service and maintain the unit only with approved replacement parts.
- Keep all instructions permanently with the product and make sure all labels are clean and visible.

Unit Information. Enter the Model Number, Serial Number, and Date of Manufacture from the label on the unit. This information is required for part or warranty issues.

Model: _____

Serial: _____

Date of Manufacture: _____



Designed and engineered by BendPak, Inc. in Southern California, USA. Made in China.

Table of Contents

Introduction	3	Operation	17
Shipping Information	4	Maintenance	20
Safety Considerations.....	4	Troubleshooting	23
Frequently Asked Questions	6	Parts Diagram	24
Specifications	7	Labels	23
Components	8	Maintenance Log	26
Setup	9		

Introduction

This manual describes the Cool Boss CB-19SL Portable Evaporative Air Cooler with Swing Louvers, which has been designed to keep homes, shops, or workplaces cool and comfortable, even on the hottest summer days.

This manual is mandatory reading for all users of the Cool Boss, including anyone who sets up, operates, maintains, or repairs it.

 **DANGER** Be very careful when setting up, operating, maintaining, or repairing this equipment; failure to do so correctly could result in property damage, product damage, injury, or (in very rare cases) death. Make sure only authorized personnel operate this equipment. All repairs must be performed by an authorized technician. Do not make modifications to the unit. This voids the warranty and increases the chances of injury or property damage. Make sure to read and follow the instructions on the labels mounted on the unit.

Keep this manual on or near the equipment so that anyone who uses or services the unit can read it.

Assistance with any Cool Boss product is available from the dealer by calling Cool Boss at **(805) 933-9970** (follow the prompts), or by emailing support@coolboss.com. Replacement parts are also available (please have the serial number and model number of the unit available).

Shipping Information

This equipment was carefully checked before shipping. Nevertheless, the shipment should be thoroughly inspected **before** signing to acknowledge that it has been received.

When the bill of lading has been signed, it tells the carrier the items on the invoice were received in good condition. **Do not sign the bill of lading until after the shipment has been inspected.** If any of the items listed on the bill of lading are missing or are damaged, do not accept the shipment until the carrier makes a notation on the bill of lading that lists the missing and/or damaged goods.

If missing or damaged goods have been discovered **after** receiving the shipment, and the bill of lading has been signed, notify the carrier at once and request that they perform an inspection. If the carrier will not do an inspection, prepare a signed statement to the effect that the carrier has been notified (on a specific date) and that the carrier has failed to comply with the request.

It is difficult to collect for loss or damage after the carrier has been given a signed bill of lading. If this happens, file a claim with the carrier promptly. Support the claim with copies of the bill of lading, freight bill, invoice, and photographs, if available. Our willingness to assist in processing the claim does not make us responsible for the collection of claims or replacement of lost or damaged materials.

Safety Considerations

Read this manual carefully before using the product. Do **not** set up or operate the product until the users are familiar with all operating instructions and warnings.

 **WARNING** **California Proposition 65.** This product can expose assemblers and operators to chemicals, including styrene and vinyl chloride, which are on a list of over 900 chemicals identified by the State of California to cause birth defects or reproductive harm. ALWAYS use this product in accordance with Cool Boss BendPak's instructions. For more information go to www.P65Warnings.ca.gov.

Safety Information





- This Cool Boss product is an air-cooling device. Use it only for its intended purpose.
- The product should only be operated by authorized personnel. Children should **not** be allowed to operate the Cool Boss. Make sure all operators read and understand the Warning labels and the *Installation and Operation Manual*. Keep the manual near the device at all times.
- **Never** operate the Cool Boss with a damaged Power Cord or Plug.
- When the product is in use, keep all body parts and loose clothing away from it.
- Only use the product indoors in a well-ventilated area. Ensure a window or door is open to allow adequate air flow.
- Do **not** make any modifications to the product. This voids the warranty and increases the chances of injury or property damage.
- Avoid using an extension cord as they can overheat. If an extension cord must be used, make sure it is a three conductor No. 14 AWG minimum with a three-prong plug/receptacle and does not exceed 50 ft. (15.2 m) in length. For up to 100 ft. (30.4 m) use a 12 AWG minimum extension cord.
- Do **not** spray the outside of the Cooler with water. Moisture can harm the motor and other parts of the electrical system.
- Only connect the power cord to a grounded, three-prong receptacle protected by a GFCI circuit breaker.

-
- Lock at least two casters before turning on the fan, to prevent the Cool Boss from moving.
 - Make a visual inspection of the product before using it. Check for damaged or missing parts. **Do not use the product if any problems are found with the unit.** Instead, remove it from service and contact the dealer, call Cool Boss at **(805) 933-9970** (follow the prompts), or email support@coolboss.com.
 - Do **not** operate the Cool Boss if the Fan has cracked or has damaged blades.
 - Do **not** operate the Cool Boss unless the Media Panels are securely in place.
 - Do **not** operate the Cool Boss within 35 ft. (10.6 m) of an open flame or spark.
 - **Always** remove the plug from the electrical receptacle by pulling on the plug itself, not on the power cord.
 - BendPak recommends making a thorough inspection of the product at least once a year. Replace any damaged or severely worn parts, decals, or warning labels.

Save these instructions!

Symbols

Following are the symbols used in this manual:

-  **DANGER** Calls attention to an immediate hazard that **will** result in death or severe injury.
-  **DANGER** Calls attention to an immediate electrical hazard that **will** result in death or severe injury.
-  **WARNING** Calls attention to a hazard or unsafe practice that **could** result in death or severe personal injury.
-  **CAUTION** Calls attention to a hazard or unsafe practice that could result in minor personal injury, product, or property damage.
-  **Tip** Calls attention to information that can aid in using the product better.

Liability Information

BendPak Inc. assumes **no** liability for damages resulting from:

- Use of the equipment for purposes other than those described in this manual.
- Modifications to the equipment without prior written permission from BendPak Inc.
- Injury or death caused by modifying, disabling, overriding, or removing safety features.
- Damage to the equipment from external influences.
- Incorrect operation of the equipment.

Frequently Asked Questions

Question: Is the Cool Boss an air conditioner?

Answer: No. It is an evaporative air cooler, sometimes called a swamp cooler. The fan pulls in hot air, a water drip spray system releases water into the Media Panels, the water droplets evaporate when they meet the hot air, lowering the ambient air temperature by as much as 26°F, (14°C), and the fan blows the cooled air in the desired direction.

Q: How much air does the Cool Boss CB-19SL cool?

A: Airflow: ≈5,890 cfm (167 cmm). Cooling area: ≈3,420 ft² (302 sq. m)

Actual airflow and area cooled will vary based on external temperature, humidity, obstructions or shape of the area to be cooled.

Q: What is the best way to set up my Cool Boss?

A: With the back of the unit facing a source of hot, dry air – which is what the Cool Boss will cool—and the front facing the area to be cooled. The Cool Boss should be near a power source as well. Also, the unit is portable, so it can be moved to where it is most needed.

Q: Does it require special water?

A: No. Clean, cold, ordinary tap water.

Q: Is it hard to control the Cool Boss?

A: Not at all. Only three easy-to-understand controls are required to operate it.

Q: How much maintenance is required?

A: Very little. Basically, keep the Water Reservoir filled with clean, cold tap water and clean the Media Panels as needed. Dirt and other pollutants from the environment can accumulate in the Media Panels and the Reservoir, so it is best to clean periodically. Do not clean the Media Panels by spraying them with high pressure water while installed in the Cool Boss! Instead, remove the Media Panels using the procedure in the **Maintenance section**, then clean them as described.

Specifications

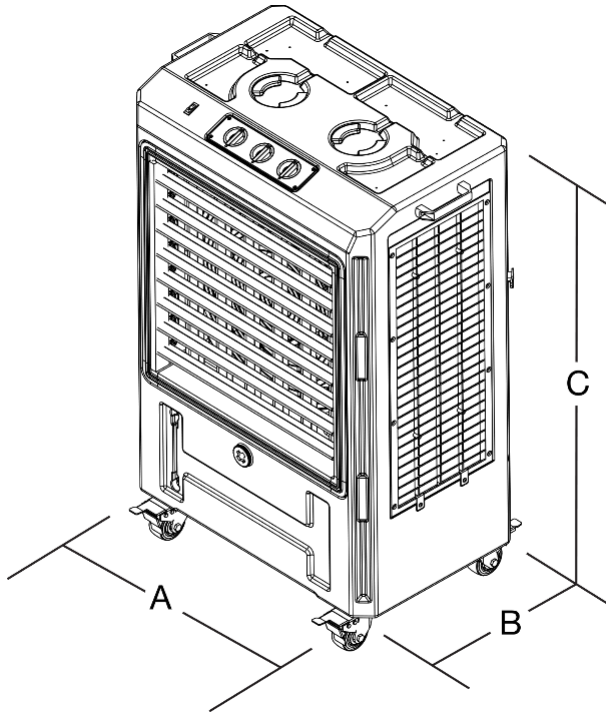

Model CB-19SL Specifications	
Dimensions (A x B x C)	31 in. x 18 in. x 44.25 in. (787 x 457 x 1,124 mm)
Fan Diameter	19 in. (483 mm)
Media Dimensions (H x W x D)	25.75 in. x 14 in. x 6 in. (654 x 356 x 152 mm)
Motor	110VAC/ 60 Hz / 1 Ph / 6.7A
Weight Empty	40 lbs. (18 kg)
Weight Full	165 lbs. (74.8 kg)
Water capacity	15 gal. (57 liters)
Consumption	0.75 – 1.25 Gal/Hr.
Max. airflow	≈6,840 cfm (194 cmm)
Sound level (avg.)	57 to 62 dB
UL® Certified	Yes
Fan speed	3-Speeds
Fan RPM Min./Max.	970 / 1,450
Fan type	Axial
Max. Input Water Pressure	99.5psi / (2 to 7 kg/cm ²) Max.
Water Pump Shutoff	The internal Water Pump incorporates an automatic low-level shutoff.
Max. Inlet Water Temp.	<113°F (45°C)
Housing	Antibacterial
Power Cord Length	15 ft. (4.5 m)
Power	110 VAC, 6.7 A Max., 60 Hz, single phase. Must be connected to a circuit protected by a GFCI circuit breaker.

Components

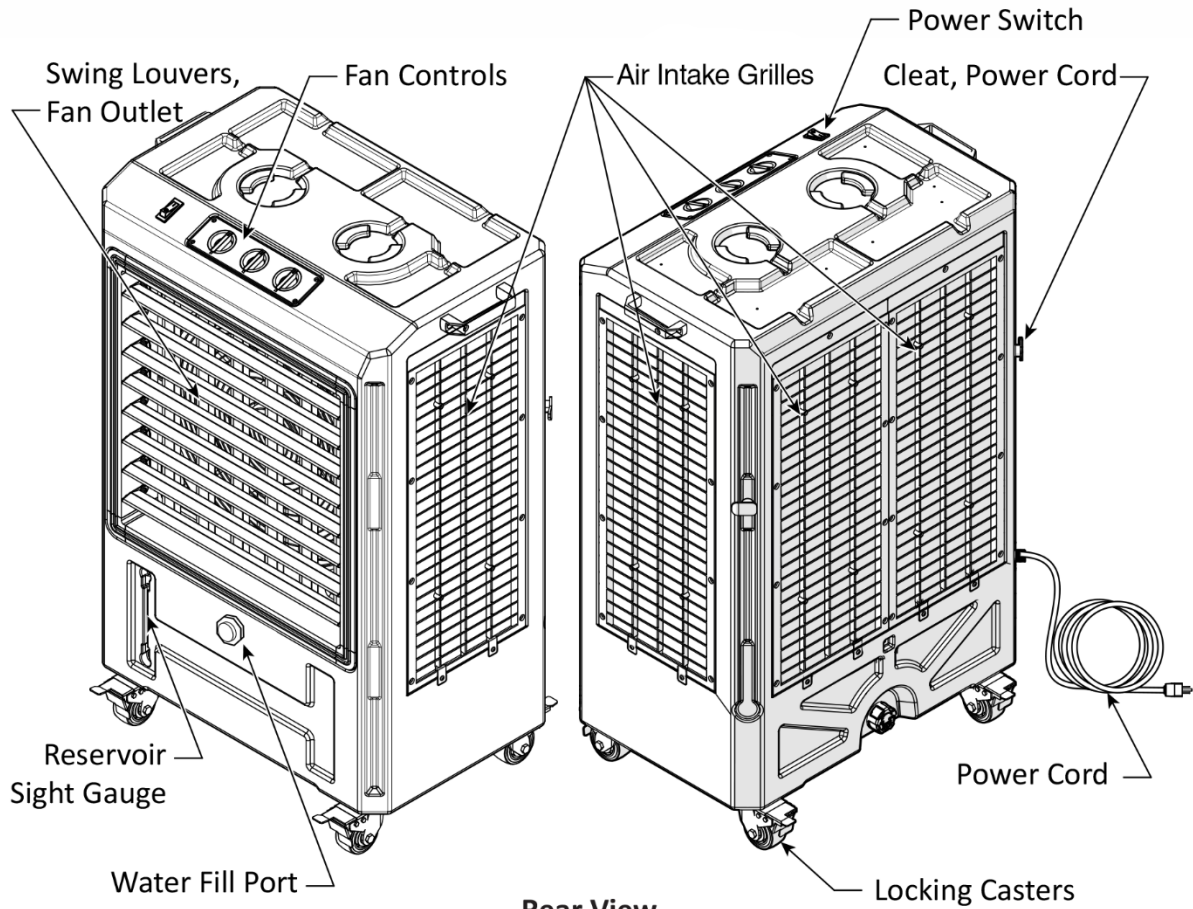

Cooling Media and retainers removed for clarity.

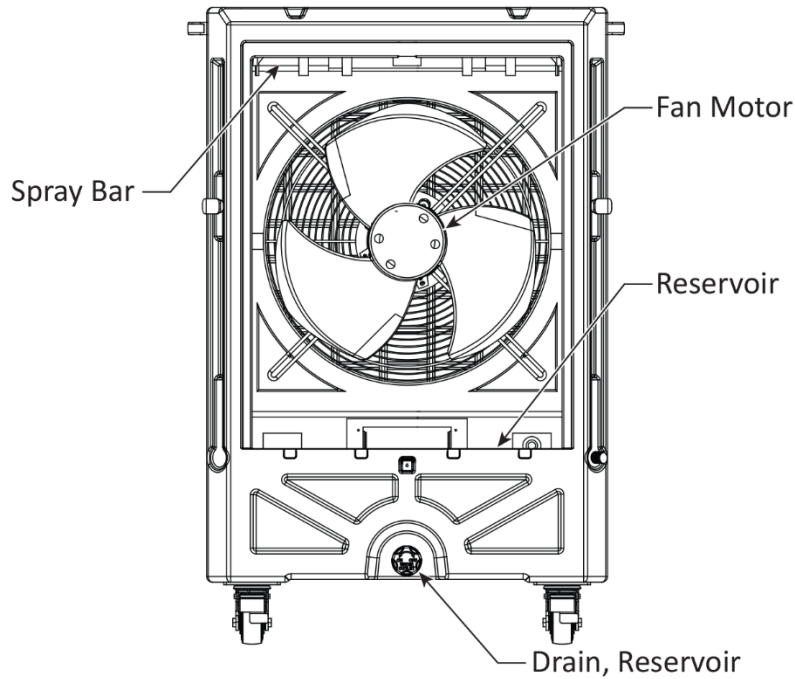

Setup

Cool Boss Set-up Steps:

1. Unbox
2. Install the Casters
3. Install the Water Reservoir Inlet
4. Install the Handles
5. Determine the Cool Boss location
6. Fill the reservoir
7. Connect to power

Tools Required for Assembly:

- Phillips Screwdrivers
- Open end metric wrenches
- Hammer
- Pry Bar

Unboxing the Cool Boss:

The Cool Boss Cooler is carefully packaged to prevent damage. Exercise care in removing the Cooler from its packaging. Be cautious of sharp edges and fasteners.

 **WARNING** Proper protective equipment must always be worn during setup and assembly of the Cooler. Leather gloves, steel-toed boots, and back belts are required.

Carefully remove the shipping container from around the Cool Boss using a hammer and pry bar.

Installing the Casters:

The Cool Boss is shipped with heavy-duty locking casters that support and allow easy movement of the Cooler around the facility.

1. Locate the casters, which are packaged in a separate box.
2. With the help of a capable assistant, carefully lay the Cool Boss on its back, as shown in the illustration on the following page. Use a drop-cloth or cardboard to lay the Cool Boss on, to prevent scratching of the surface.
3. Tightly install the four swivel Casters using the four bolts and flat washers provided (for each Caster). See illustration on the following page.

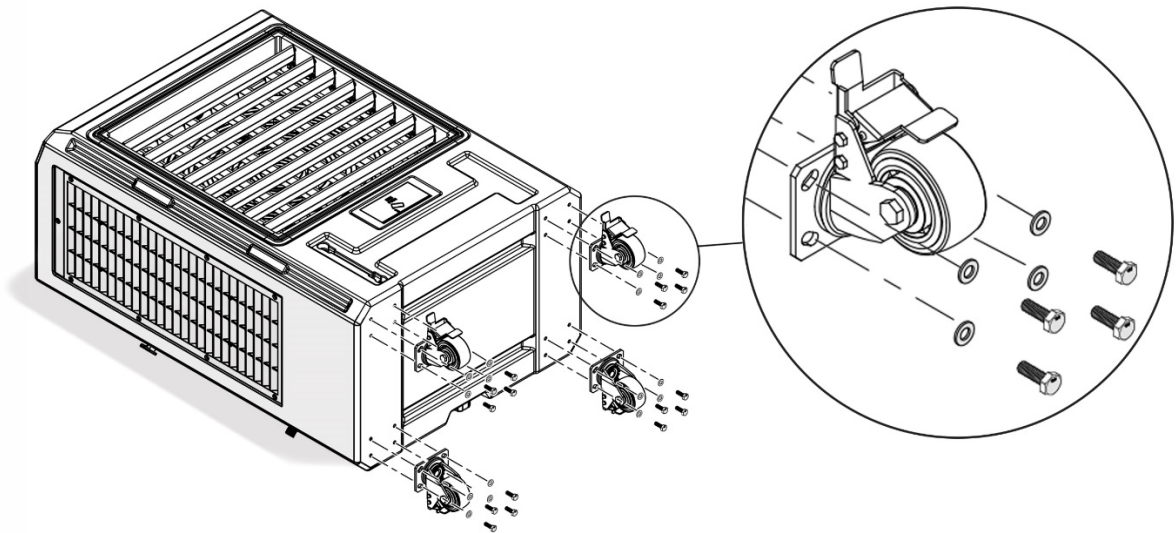

4. Lock the two rear Casters by pushing down on the larger pedal. Pushing down on the small pedal releases the lock. See illustration below.

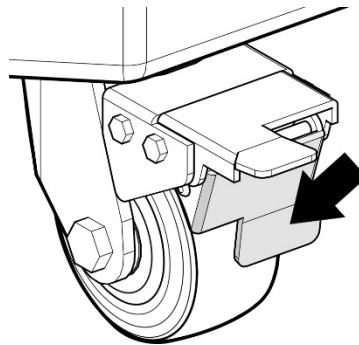

5. Have an assistant help set the Cool Boss back upright and onto its Casters.
6. Install the Water Reservoir Inlet by threading it clockwise onto the threads on the corner of the Cool Boss, as shown in the illustration below.
7. Insert the Gasket into the Water Reservoir Inlet, ensuring that it is fully seated within the opening.

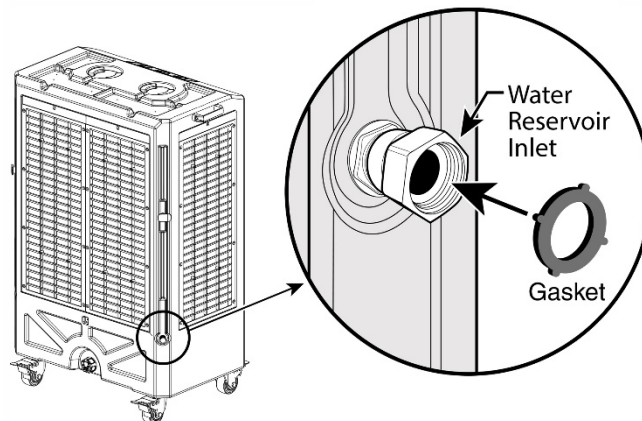

8. Install one Handle to each side of the Cool Boss using the provided screws, as shown in the illustration below.

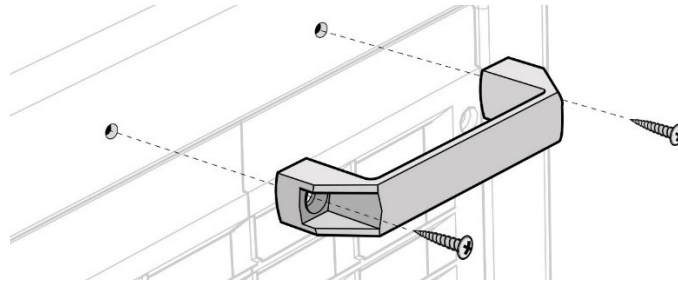

Finding a Location for the Cool Boss:

Find a suitable location for the Cool Boss (hot air to rear, cooling area to front). The Cool Boss should be indoors, near an appropriate water source, and a power outlet protected by a GFCI circuit breaker. It should also be located in a low-traffic, well-ventilated area.

⚠ WARNING This equipment has internal arcing or sparking parts that should **not** be exposed to flammable vapors. The unit must **not** be located in a recessed area or below floor level.

⚠ WARNING Verify the floor will support the weight of the Cool Boss with a **full** reservoir. Also verify the floor is level, well-constructed and stable enough to prevent the Cooler from tipping over.

1. Unlock the Casters and roll the Cool Boss to the desired location. Direct the Fan outlet toward the area to be cooled.

⚠ CAUTION To ensure efficient operation, the Cool Boss requires adequate airflow for intake and exhaust. Verify that a window or door is open.

2. Maintain 36 in. (914 mm) minimum of clear, open space behind the Cool Boss for adequate heat air intake.

⚠ WARNING Verify the Power Cord is carefully routed to prevent a tripping hazard and is not routed under carpets or across sharp edges.

3. Once a location has been found and the Cool Boss moved into position, **lock a minimum of two Casters** by pressing down on the large pedal locking mechanism on each Caster. To unlock the Casters, press down on the small pedal.

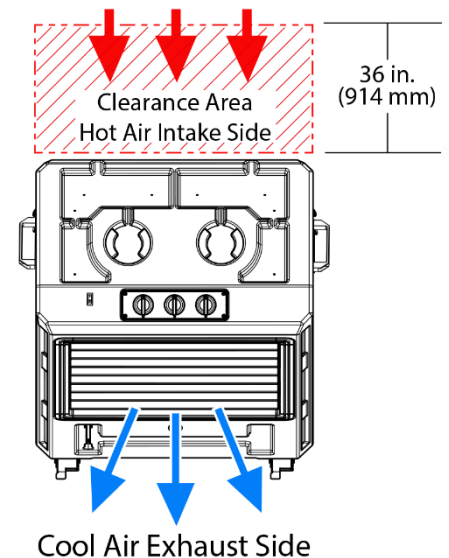

⚠ CAUTION Do not start the Cool Boss until a **minimum** of two Casters have been locked. This ensures that unintended movement caused by the thrust of the Fan will not occur and cause damage.

Filling the Water Reservoir:

Model CB-19SL water capacity: ≈ 15 gal. (57 liters)

⚠ CAUTION Use only cold, clean water. Do **not** add detergents or additives of any kind.

⚠ CAUTION Fill the Water Reservoir to maximum capacity before first use. Failure to do so will prevent the low water shutoff from engaging and the fan from starting.

There are two options to fill the Reservoir; using a hose connected to the 3/4 in. Water Reservoir Inlet located on the left rear corner, or manually, filling the Reservoir through the Manual Fill Port on the front of the Cooler.

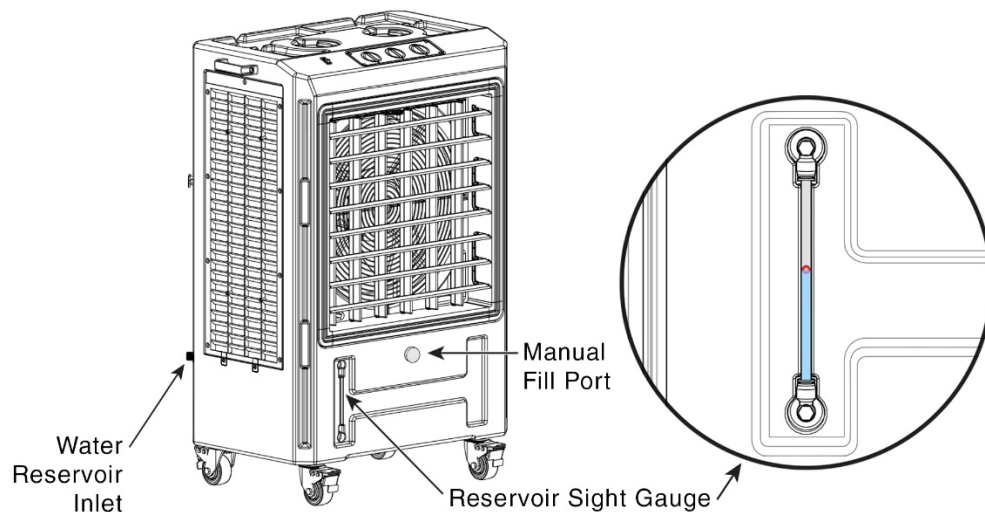

Option 1: Manual Fill Port. Filling the Cool Boss with water through the Manual Fill Port on the front of the unit allows the Cooler to be easily moved around the facility without the restriction of being connected to a hose.

1. Remove the Water Fill Cap, located on the front of the Cool Boss. Set the cap aside.
2. Using a water hose or a bucket and a funnel, fill the reservoir. The water level may be viewed through the Reservoir Sight Gauge to the left of the Manual Fill Port. Do **not** overfill.

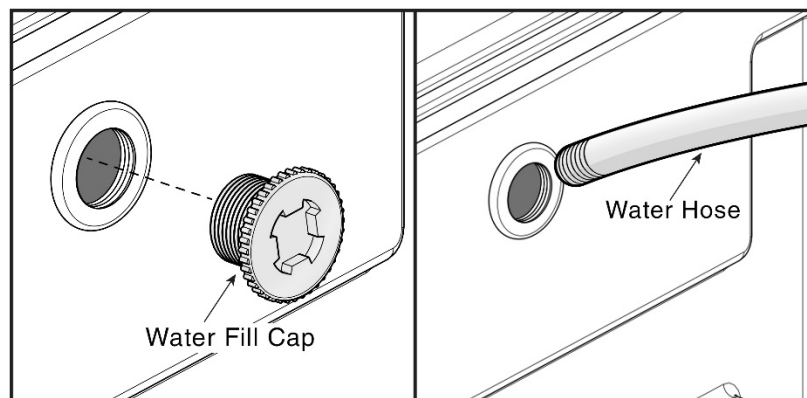

3. After filling, replace the Water Fill Cap and clean up and dry any water spilled on the Cool Boss or the floor around the unit.

Option 2: Auto-fill Hose Connection.

Connect to the Water Reservoir Inlet on the left rear corner of the unit using a standard 3/4 in. hose that is rated to 28 to 99.5psi / (2 to 7 kg/cm²) maximum water pressure at the location. See illustration below. Open the facility water supply valve and verify that there are no leaks at the Cool Boss fitting. A hose is **not** supplied with the Cool Boss.

When utilizing the Water Reservoir Inlet, the Reservoir Float Valve will close to stop the water flow before the maximum fill level is exceeded.

⚠ CAUTION Do **not** connect to a water source with a supply pressure in excess of 99.5psi / (2 to 7 kg/cm²).

⚠ CAUTION Verify the Water Hose is carefully routed to prevent a tripping hazard, and is not routed across sharp edges.

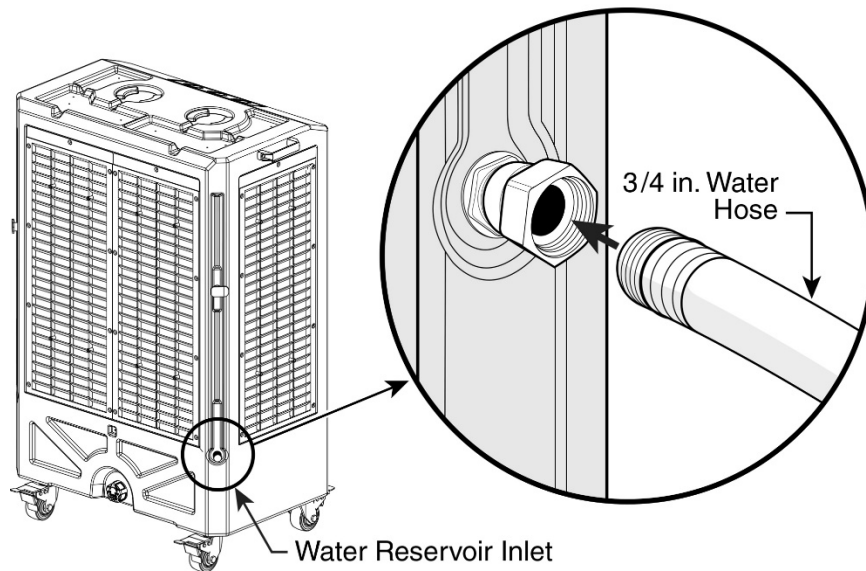

Illustration not to scale

Connecting to Power:

Before connecting this unit to a power source, verify the required voltage by checking the model nameplate affixed to the unit. Cool Boss models marked CB-19SL indicate 110 VAC operation; **Cool Boss recommends connecting to a Ground Fault Circuit Interrupting (GFCI) outlet or a circuit protected by a GFCI circuit breaker.** The GFCI acts as a Circuit Breaker in the event of a Ground Fault. A Ground Fault occurs when the power conductor comes into direct contact with the equipment's frame or Ground.

If the Cool Boss is equipped with a plug **not** compatible with the location's current power source, a licensed electrician must be contacted—to install a separate 15 Amp circuit protected by a fuse or circuit breaker with an appropriately grounded power receptacle in accordance with all national and local electrical codes.

An electrician is not required to connect the Cool Boss with a 110 VAC power source as shipped from the factory. Units operating at 110 VAC have the appropriate plug attached.

⚠ DANGER All electrical work must be accomplished by a licensed electrician in accordance with national and local electrical codes. If a licensed electrician is not used, the warranty is voided and everyone who uses the cooler will be put in danger of injury or, in rare cases, death.

Additional Electrical Information:

Damage caused by improper electrical installation (such as not grounding the unit) voids the warranty.

⚠ WARNING Disconnect the unit from the power source **before** performing **any** troubleshooting or maintenance. Make sure the unit cannot be re-energized until all work is done.

⚠ WARNING Plug into a properly grounded GFCI electrical receptacle only.

⚠ WARNING **Never** remove the ground prong from the plug end of the power cord.

Extension Cords

If an extension cord is required, use only cords with a polarized plug/receptacle no longer than 100 ft. (30.5 m) in length. Never use an extension cord that is not properly rated to handle the electrical load. When making connections, ensure all local and national electrical codes are adhered to.

Minimum requirements for Extension Cords	
25-50 ft. (7.6-15.2 m) in length	Minimum 14 AWG
Total to 100 ft. (30.5 m) in length	Minimum 12 AWG

⚠ WARNING For generator users and or areas with frequent brownout conditions. Motor failure due to excessive high or low voltage is not covered under warranty. If the Cool Boss is powered by a Generator or operated in an area with frequent brownouts, verify that the power source can provide the required current and voltage. While voltage variations are common ($\pm 5\%$) both high and low voltage episodes in excess of 15% to 20% can cause Electrical Motor overheating and premature Motor failure.

Low voltage will cause the Motor to draw more electrical current to deliver the same amount of force to the Fan Blades. Excessive current overheats the Motor Windings, eventually burning through the insulation and resulting in complete Motor failure.

High voltage episodes can cause premature failure of electrical and electronic components due to overheating.

Operation

IMPORTANT NOTICE! Fill the water reservoir to maximum capacity before first use. Failure to do so will prevent the low-water shutoff from engaging and the fan from starting.

- ⚠ WARNING** The Cool Boss should only be operated by authorized, trained personnel. This includes reviewing and understanding the Operation Manual and Safety Labels on the unit. Do *not* allow children or impaired people to operate the Cool Boss.
- ⚠ WARNING** *Never* roll anything heavy or sharp over the power cord. Find a location where people will not be walking over the power cord, presenting a tripping hazard.
- ⚠ WARNING** *Never* operate the Cool Boss unless the Ground Fault Circuit Interrupter (GFCI) is functioning.
- ⚠ WARNING** *Never* remove the ground prong from the plug end of the power cord. Do *not* operate the unit if the power cord is damaged.
- ⚠ WARNING** Do *not* run the power cord under a rug or other flammable material.
- ⚠ WARNING** Use only in a well-ventilated open environment with a fresh air supply.
- ⚠ WARNING** The Cool Boss area must be free from airborne pollutants, flammable gases and contaminants.
- ⚠ WARNING** Ambient operating temperature must remain between +65° to +113°F (+18° to +45°C)
- ⚠ WARNING** *Never* spray the Cool Boss with water as it is not sealed and moisture may harm the Motor or other electrical system components.
- ⚠ WARNING** Do *not* operate near open containers of flammable liquids or gases.
- ⚠ WARNING** Always maintain a minimum 50 ft. (15 m) from any open flame or sparks.
- ⚠ WARNING** The Cool Boss is *not* designed to be used by children or people with reduced physical, sensory, or mental capabilities or lack of experience and knowledge unless they have been given supervision or instruction regarding proper use by a person responsible for their safety.
- ⚠ WARNING** *Never* operate the Cool Boss unless all Media Panels are securely in place.
- ⚠ WARNING** Always dry the Media Panels after use by turning off the Water Supply and running the Fan without circulating water. This may take from 20 to 60 minutes depending on temperature and humidity.

Operating the CB-19SL:

Control Panel

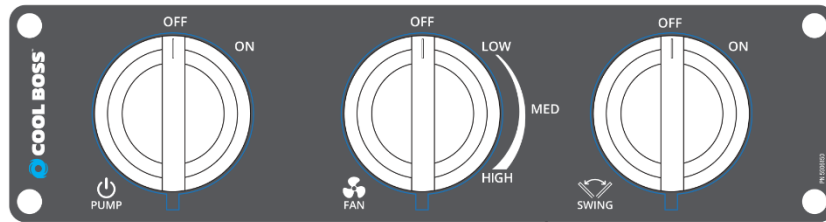

- **Swing Control** – Rotary Switch On/Off. Initiates the Swing Louver left-right movement.
- **Water Pump** – Rotary Switch On/Off. Applies power to the Water Pump, providing water to the Spray Bar, which then distributes it over the Cooling Media Panels.
- **Fan Speed** – Rotary Switch On-Off and three-speed settings: low, medium and high.

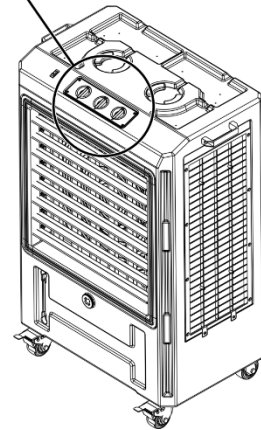

Operating the Cool Boss:

IMPORTANT! Fill the water reservoir to maximum capacity before first use. Failure to do so will prevent the low-water shutoff from engaging and the fan from starting.

1. Verify that ALL controls are in the **OFF** position:
2. Open a door or window if using the Cool Boss indoors. Sufficient airflow for intake and exhaust is critical.

⚠ CAUTION **The Cool Boss Pump will be damaged if allowed to operate without water.** Verify that there is water in the Water Reservoir before activating cooling modes.

3. Verify that the Cool Boss Water Reservoir is full (Reservoir Sight Gauge-See Page 12).
4. Verify that a minimum of two Casters are locked to prevent the Cool Boss from moving from the additional thrust of the Fan.
5. Plug the Cool Boss electrical cord into an appropriate electrical outlet protected by a GFCI.
6. Turn the Cool Boss **ON** using the Power Switch to the left of the Control Panel.

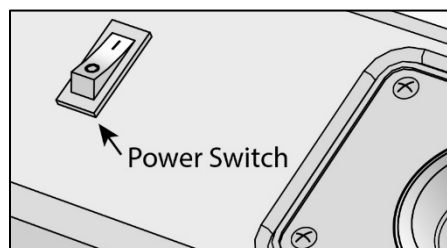

7. Rotate the Fan Speed Switch to **LOW**, applying power to the Fan.
8. Turn the Water Pump switch to the **ON** position.
9. Once the top 30% of the Media Panels are saturated, Verify the fan is operating and cool air is beginning to move through the Cooler exhaust. If the Fan is operating normally, select the desired fan setting to cool the selected area.

⚠ WARNING Rotating Fan Blades! Keep hands, fingers, and loose clothing away from the Fan when it is running.

Using the Swing Louver Function:

1. Manually adjust the horizontal Louvers to direct the cool air up or down. The Vertical Louvers are mechanically driven and will swing to the left and right when the Swing Control Switch is in the **ON** position.

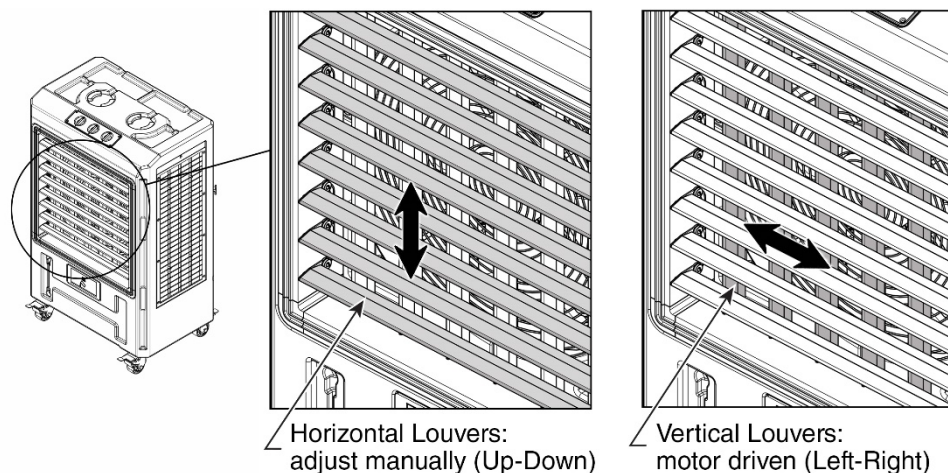

⚠ CAUTION Before applying power to the Swing Louvers, verify that there is nothing that will physically block or impede the motion of the Louvers.

⚠ CAUTION Attempting to adjust the Vertical Louvers by hand may cause the mechanism or Louvers to break and disengage from the Drive Motor.

2. Move the Swing Control Switch to the **ON** position. The Louvers will begin to swing left and right.

Shutting Down the Cool Boss:

1. Turn the Water Pump Switch to the **OFF** position.
2. Dry the Media Panels by operating the fan without running water.

⚠ WARNING To reduce the possibility of bacteria and mold growth, dry the Media Panels at the end of each day. Running the Fan without circulating water for 20 to 60 minutes should dry the Media Panels in most cases. Media drying times will vary based on temperature, humidity, and fan speed.

3. Turn the Swing Control Switch to the **OFF** position, if required.
4. After the Media Panels are dry, turn the Fan Speed switch to the **OFF** position.
5. Turn the main Power Switch to **OFF**. See the **Maintenance** Section for guidance on storing the Cool Boss.

Maintenance

 **DANGER** Disconnect the unit from its power source **before** performing any maintenance! Verify the unit is locked out from power and cannot be energized while maintenance is being performed. If the shop or organization has Lockout/Tagout policies, make sure to implement them before servicing the Cool Boss.

 **WARNING** Rotating Fan Blades can cause severe injury! Keep hands and loose clothing clear!

 **WARNING** Disconnect the Power Cord when cleaning the Cool Boss and exercise care to avoid splashing water on the Motor or internal electronics.

Maintaining the Cool Boss:

- **Daily.** Turn off the Cooling Pump and run the Fan to dry the Media Panels, to inhibit the growth of bacteria, mold, and mildew. Typically, Media drying can take 20 to 60 minutes depending on the current temperature and humidity.
- **Weekly.** Change the Cool Boss Reservoir water when it gets dirty. Dirt and other pollutants from the environment can get into the water and reservoir. Cool Boss recommends draining and cleaning the reservoir weekly or more often depending on the frequency of use and the cleanliness of the environment. See instructions on the following page.
- **Monthly.** Drain and clean the Cool Boss Water Reservoir. Dirt and other pollutants from the environment can settle in the Water Reservoir. Regular cleaning can remove these contaminants and reduce the build-up of minerals.
- **Monthly.** Clean the outside of the unit. Do *not* use harsh chemicals. Unplug the Cool Boss and wipe down the outside of the unit with a damp cloth. The frequency of use and the cleanliness of the environment will affect the frequency of cleaning required.

 **WARNING** Do *not* spray the Cool Boss with water. The electronics are not sealed. Water can damage the motor and other parts of the electrical system.

- **Monthly.** Remove the Media Panels and clean them as detailed below. Dirt and other pollutants from the environment can become caught in the Media Panels. Cleaning them regularly helps to keep the air fresh and clean.

 **WARNING** Do *not* operate the Cool Boss if maintenance issues are found. Instead, remove it from service. Assistance with any Cool Boss product is available from the dealer, by calling Cool Boss at **(805) 933-9970**, or by emailing support@coolboss.com. Cool Boss may also be contacted for parts replacement (please have the serial and model numbers of the unit available).

Cleaning the Reservoir:

1. The Media Panels must be dry before removing. If they are wet, run the Fan without running the Cooling Pump until they are dry.
2. Turn off and then unplug the Cool Boss.

⚠ WARNING Disconnect the unit from its power source before performing any maintenance! Verify the unit is locked out from power and cannot be energized while maintenance is being performed. If the shop or organization has Lockout/Tagout policies, make sure to implement them before servicing the Cool Boss.

3. Remove and retain the Fasteners securing the Media Retainers and then remove the Retainers and Media Panels. Take care not to damage the Media Panels. A little pressure may be needed to remove them.
4. Rotate the plug at the bottom of the reservoir and drain any water into a container or appropriate drain. See illustration below.

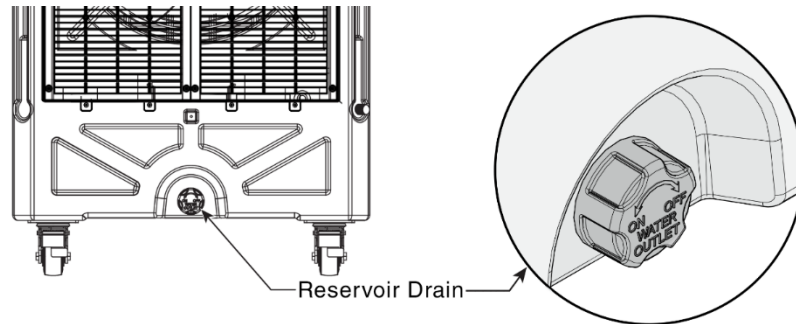

5. Remove any residual water with rags or a wet/dry vacuum.
6. Wipe with clean rags and remove any mineral deposits. Do *not* use any harsh chemicals.
7. Refill the reservoir with clean water and replace the Media Panels. The Cool Boss is now ready to use.

💡 Tip Wearing gloves is recommended when handling the Media Panels.

Cleaning the Media:

1. The Media Panels must be dry before removing them from the Housing. If the Media Panels are wet, run the Fan without running the Cooling Pump until they are dry.
2. Turn off and then unplug the Cool Boss.

⚠ WARNING Disconnect the unit from its power source before performing any maintenance! Verify the unit is locked out from power and cannot be energized while maintenance is being performed. If the shop or organization has Lockout/Tagout policies, make sure to implement them before servicing the Cool Boss.

3. Remove and retain the fasteners and clips securing the Air Inlet Grilles/Media Panels to the Housing. See illustration to the right.

Note that each of the four Media Panels is secured to the inside of an Air Inlet Grille. At the rear of the Unit, the two Air Inlet Grilles are attached together as a single piece and should be removed together. Do *not* try to remove each of the rear Air Inlet Grilles/Media Panels individually as damage may occur.

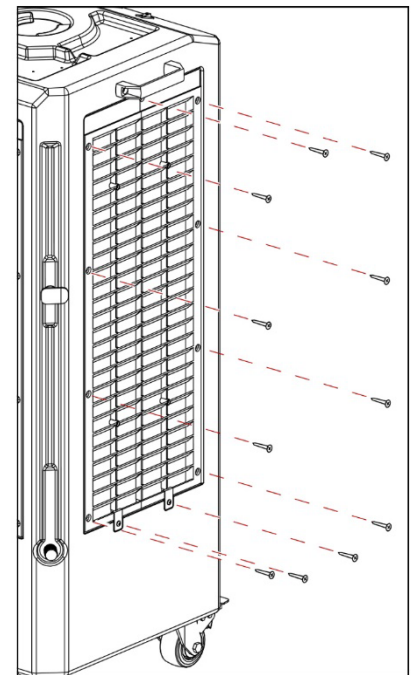

4. Remove each Air Inlet Grille/Media Panel from the Housing, taking care not to damage the Media Panel. A little pressure may be needed to remove them.
5. Carefully remove the four Media Retaining Pins, Washers and Nuts securing each Media Panel to its Air Inlet Grille. See illustration to the right.
6. Rinse the Media Panel under running water to clean and use a soft brush or rag to gently remove accumulated dirt. Do **not** use highly pressurized water or air to clean the Media Panel.
7. Dry the Media Panel thoroughly before attempting to reinstall it in the Cool Boss.
8. Applying gentle pressure, put each Media Panel back into its Air Inlet Grill, aligning the holes in the Media Panel with those in the Air Inlet Grille.
9. Re-attach the Media Retaining Pins, Washers and Nuts, taking care not to overtighten the Nuts—causing damage to the Media Panels.
10. Place each Air Inlet Grille/Media Panel back into the Cool Boss. Gentle pressure may be required to move the Media Panel and Air Inlet Grille into place.
11. Secure the fasteners and clips holding the Air Inlet Grilles/Media Panels in place within the Housing.

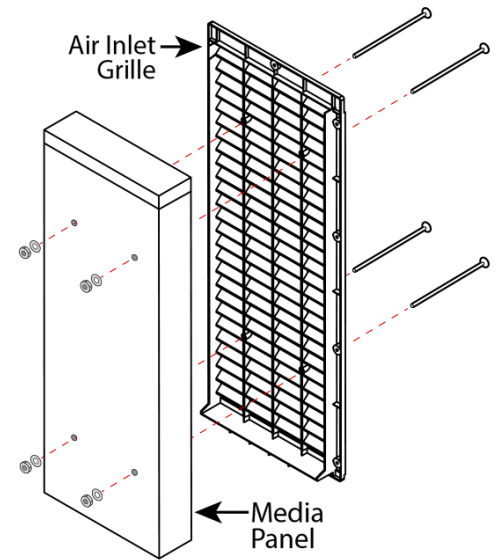

Storing the Cool Boss:

1. Dry the Media Panels or verify they are dry. The Media Panels must be dry before removing. If they are wet, run the Fan without running the Cooling Pump until they are dry.
2. Drain the Reservoir, clean and wipe dry. See instructions above for **Cleaning the Reservoir**.
3. Unplug or disconnect from power and secure the electrical cord. Wrap the electrical cord securely around the Power Cord Cleats on the Cool Boss, as shown in the illustration below.
4. Cover the Cool Boss to prevent dust build-up and store it in a dry, protected area.

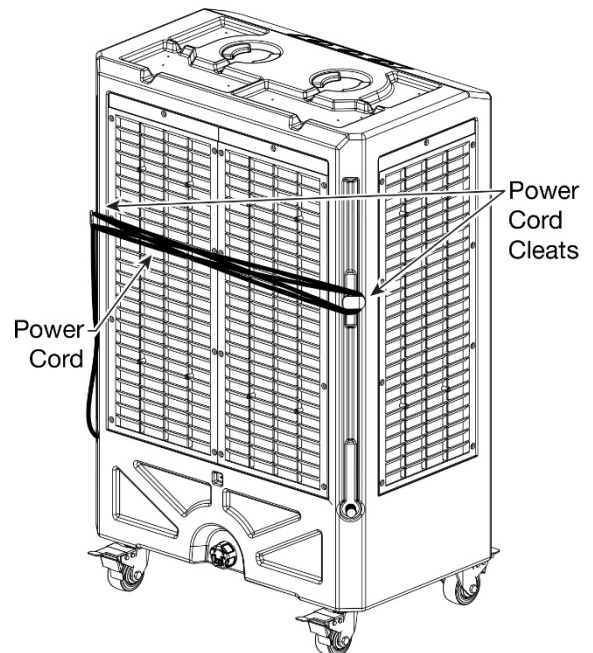

Troubleshooting

⚠ WARNING This Evaporative Cooler uses electrical energy. If the shop or organization has Lockout/Tagout policies, make sure to implement them before performing any Troubleshooting.

Issue	Probable Cause	Action to Take
Control Panel inoperative.	<ul style="list-style-type: none"> No power. Circuit Breaker open. Control Panel component failure. 	<ul style="list-style-type: none"> Check the power supply. Reset the circuit breaker. Replace the panel.
Unit not working.	<ul style="list-style-type: none"> No power. 	<ul style="list-style-type: none"> Power cycle the unit on-off. Verify the power supply is functional.
Fan not working or moving slowly.	<ul style="list-style-type: none"> Fan is stuck. Fan is broken. Brownout or low voltage. 	<ul style="list-style-type: none"> Check for blockage and remove. Repair fan. Correct voltage supply issue.
Motor not working.	<ul style="list-style-type: none"> Control Panel is not working. Motor failure 	<ul style="list-style-type: none"> Replace Control Panel. Replace Motor.
Drain leaks.	<ul style="list-style-type: none"> Drain Plug is not tight Drain Plug is cross-threaded. O-Ring is missing 	<ul style="list-style-type: none"> Tighten Drain Plug. Replace Plug if thread is damaged. Replace O-Ring.
Fan dripping water.	Water plumbing is disconnected or leaking.	Check internal water connections and tubing.

Assistance with all Cool Boss products is available from the dealer, by calling Cool Boss at **(805) 933-9970** (follow the prompts), or by emailing support@coolboss.com. Replacement parts are also available (please have the serial number and model number of the unit available).

Parts Diagram

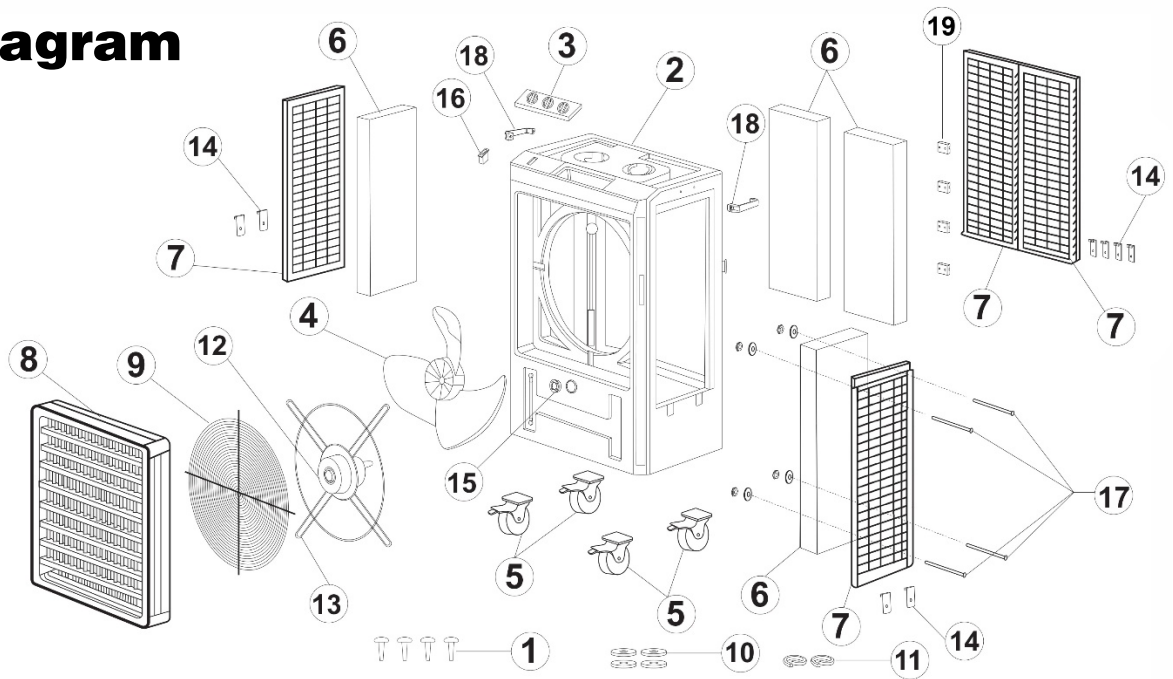

Item	Qty.	Part Number	Description
1	82	5326995	Screw
2	1	5326996	Housing
3	1	5326997	Control Panel
4	1	5326998	Fan Blade
5	4	5326999	Caster
6	4	5326684	Media Panel
7	4	5326685	Air Inlet Grille
8	1	5326686	Oscillating Frame
9	1	5326687	Grille
10	24	5326688	Flat Washer
11	16	5326689	Spring Washer
12	1	5326690	Motor
13	1	5326691	Motor Bracket
14	8	5326692	Metal Retaining clip
15	1	5326693	Water Inlet Plug
16	1	5326694	Power Toggle Switch
17	16	5326695	Media Retainer
18	2	5326697	Handle
19	4	5326698	Plastic Grille Retainer

Labels

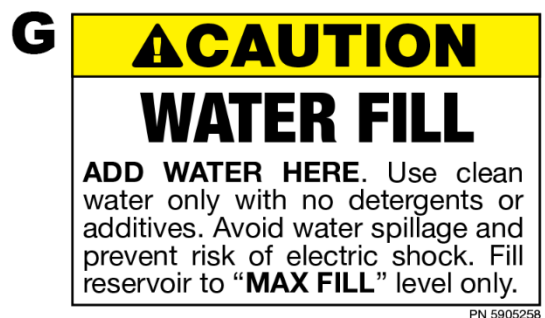
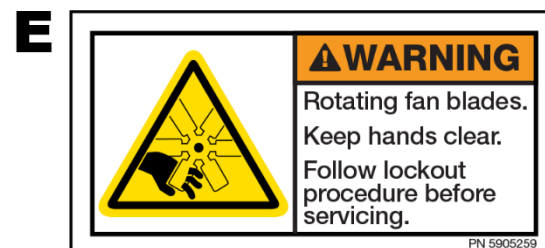
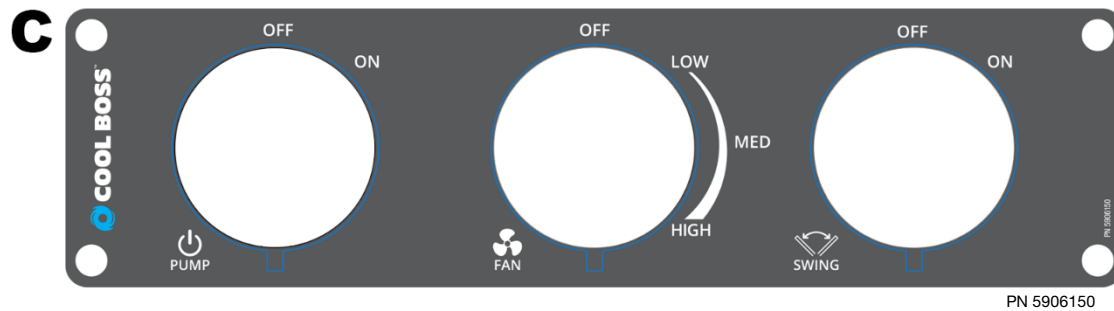
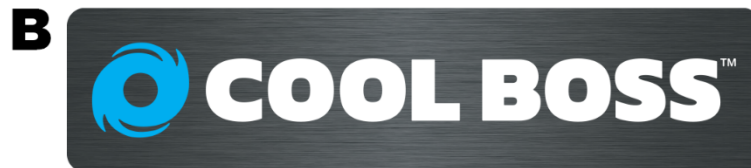
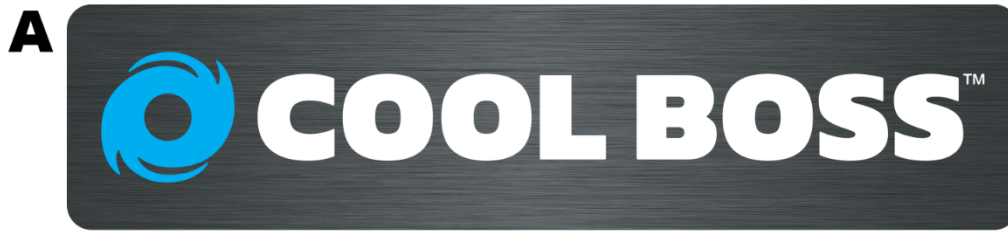

H

⚠ DANGER

Unplug unit from power source before removing media pad. Fan can start unexpectedly due to the timer control feature.

PN 5905261



PN 5906163

J

BendPak 30440 Agoura Road
Agoura Hills, CA 91301 USA

MODEL NO. / N° DE MODÈLE	SERIAL NO. / N° DE SÉRIE
DESCRIPTION	
VOLTAGE / TENSION	
UPC	DATE CODE
	VER. REV.

SCAN TO FIND LATEST MANUAL & PARTS LIST

⚠ DANGER! Disconnect Power Before Servicing
Débrancher l'alimentation avant l'entretien

WARRANTY VOID IF DATA PLATE IS REMOVED
GARANTIE NULLE SANS LA PLAQUE D'INFORMATION

MADE IN CHINA / FABRIQUÉ EN CHINE PN 5906152

PN 5906152

K

CALIFORNIA PROPOSITION 65

⚠ WARNING ⚠

WARNING! This product can expose you to chemicals including styrene and vinyl chloride which are on the list of over 900 chemicals identified by the State of California to cause cancer, birth defects or reproductive harm. ALWAYS use this product in accordance with the manufacturer's instructions. For more information, go to www.p65warnings.ca.gov.

PN 5905775

L

<p>NOTICE</p> <p>IMPORTANT NOTICE Fill water reservoir to MAX capacity before first use. Failure to do so will prevent the low-water shutoff from engaging and the fan from starting.</p>	<p>NOTICE</p> <p>IMPORTANT NOTICE Fill water reservoir to MAX capacity before first use. Failure to do so will prevent the low-water shutoff from engaging and the fan from starting.</p>
--	--

PN 5906141

PN 5906141



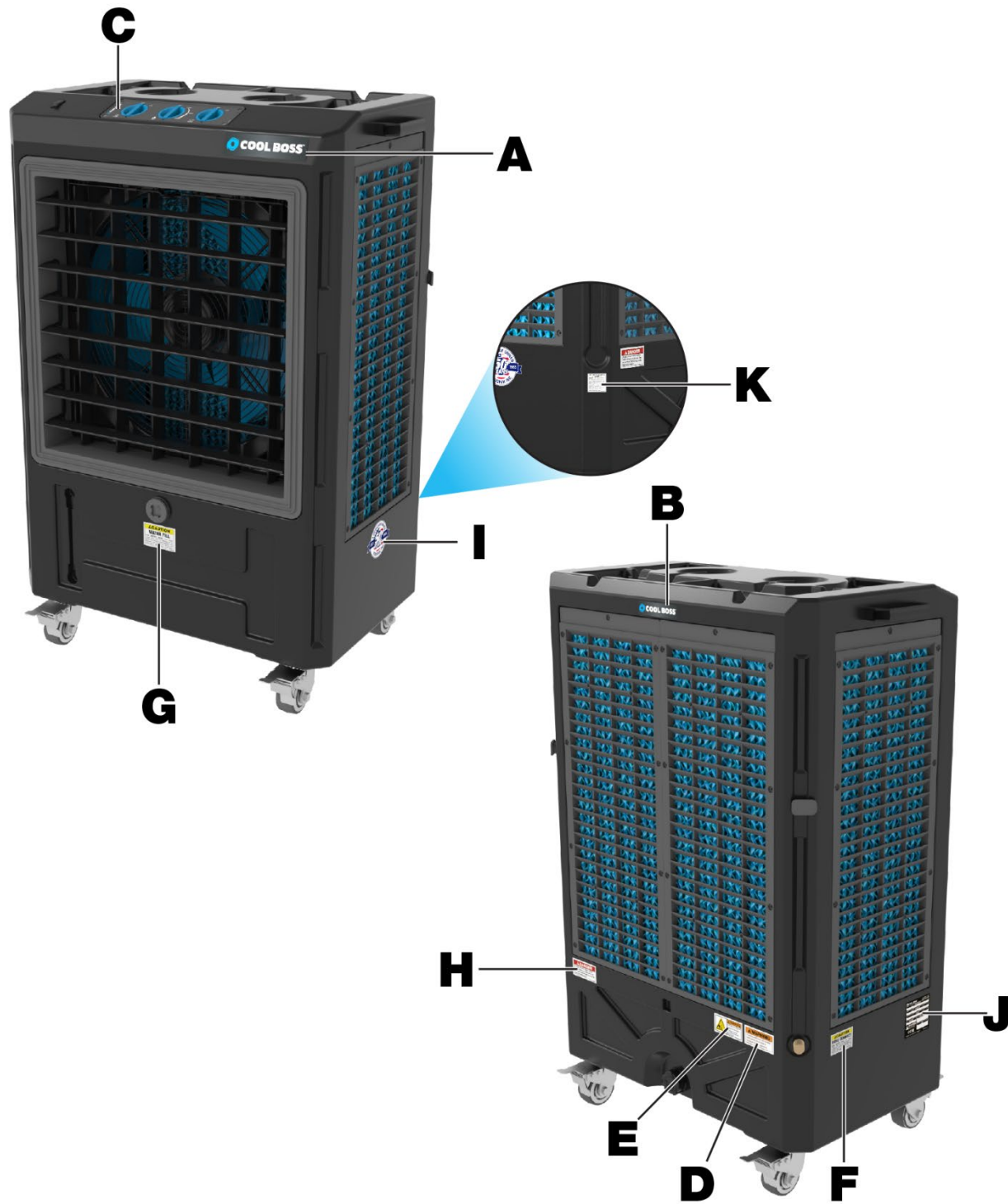



30440 Agoura Rd.
Agoura Hills, CA 91301 USA
CoolBoss.com

2026 BendPak Inc. All rights reserved.

