



Access Plus™
Bottom Drawer
Chest Freezer
Use & Care Guide

El Congelador Inferior
Pecho del Cajón
Guía para su uso y cuidado

Tiroir du Bas
Congélateur de Poitrine
Guide d'utilisation et d'entretien

Models, Modelos, Modèles
183.13401300
183.13601300

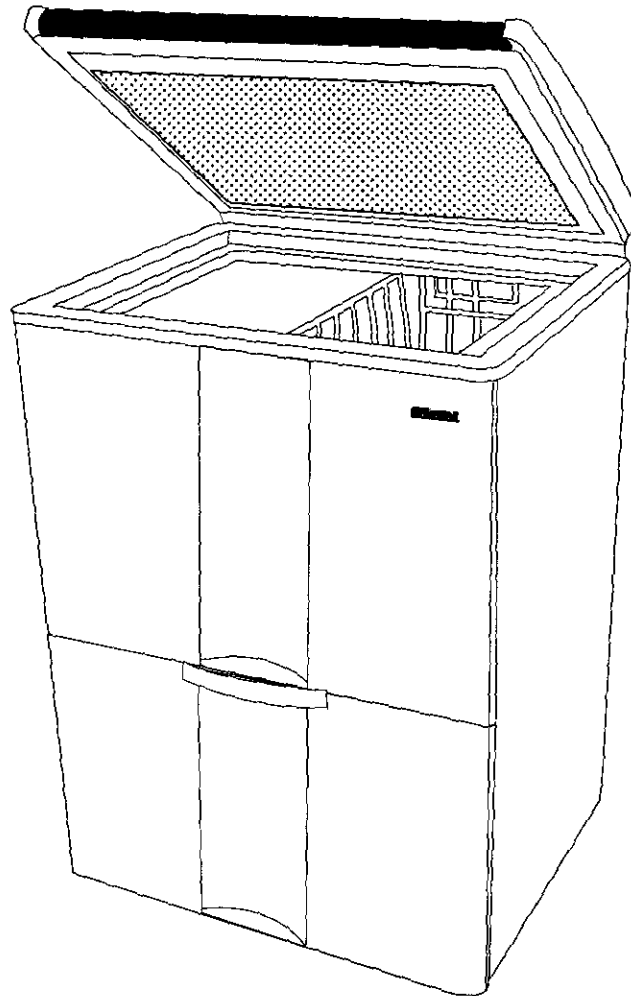

Sears, Roebuck and Co., Hoffman Estates, IL 60179 U.S.A.
Sears Canada Inc., Toronto, Ontario, Canada M5B 2B8

TABLE OF CONTENTS

Record Serial/Model Numbers	2
Safety	2-3
Warranty	3
Canada - Limited Warranty	4
First Steps	5
Energy Saving Tips	5
Setting the Temperature Control	6
Freezer Features	6
Care and Cleaning	7
Power Failure / Freezer Failure	7
Troubleshooting Guide	8-9
Sears Service	10
Sears Canada Customers	10

SERIAL / MODEL NUMBERS

READ AND SAVE THESE INSTRUCTIONS

This Use and Care Guide provides specific operating instructions for your model. Use your freezer only as instructed in this guide. These instructions are not meant to cover every possible condition and situation that may occur. Common sense and caution must be practiced when installing, operating, and maintaining any appliance.

Record Your Model and Serial Numbers

Record the model and serial numbers in the spaces provided below. The serial plate is located on the rear exterior wall.

Model Number: 183.13401300

or: 183.13601300

Serial Number: _____

Purchase Date: _____

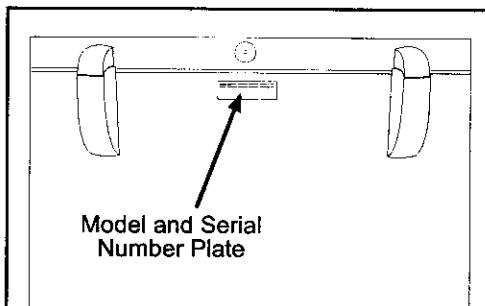

© Sears, Roebuck and Co.

IMPORTANT SAFETY INSTRUCTIONS

READ ALL INSTRUCTIONS BEFORE USING THIS FREEZER.

⚠ WARNING FOR YOUR SAFETY

Do not store or use gasoline, or other flammable vapors and liquids in the vicinity of this or any other appliance. Read product labels for flammability and other warnings.

⚠ WARNING CHILD SAFETY

- Destroy carton, plastic bags, and any exterior wrapping material immediately after the freezer is unpacked. Children should never use these items to play. Cartons covered with rugs, bedspreads, plastic sheets or stretch wrap may become airtight chambers, and can quickly cause suffocation.
- Remove all staples from the carton. Staples can cause severe cuts, and destroy finishes if they come in contact with other appliances or furniture.
- An empty, discarded ice box, refrigerator, or freezer is a very dangerous attraction to children.
- Remove and discard any spacers used to secure the shelves during shipping. Small objects are a choke hazard to children.

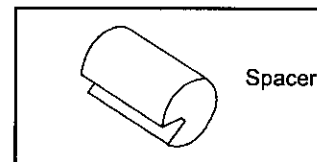

Remove the door(s) of any appliance that is not in use, even if it is being discarded.

Proper Disposal of Your Refrigerator/Freezer

⚠ WARNING Risk of child entrapment. Child entrapment and suffocation are not problems of the past. Junked or abandoned refrigerators or freezers are still dangerous, even if they will sit for "just a few days." If you are getting rid of your old refrigerator or freezer, please follow the instructions below to help prevent accidents.

BEFORE YOU THROW AWAY YOUR OLD REFRIGERATOR/FREEZER:

- Remove doors.
- Leave shelves in place so children may not easily climb inside.

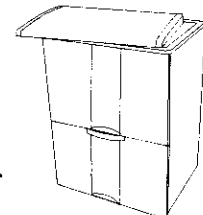

⚠ WARNING ELECTRICAL INFORMATION

These guidelines must be followed to ensure that safety mechanisms in the design of this freezer will operate properly.

- **Refer to the serial plate for correct electrical rating.**
The power cord of the appliance is equipped with a three-prong grounding plug for your protection against shock hazards. It must be plugged directly into a properly grounded three-prong receptacle and protected with a 15 amp time delay fuse or circuit breaker. The receptacle must be installed in accordance with local codes and ordinances. Consult a qualified electrician. Receptacles protected by Ground Fault Circuit Interrupters (GFCI) are **NOT RECOMMENDED**. **Do not use an extension cord or adapter plug.**
- If voltage varies by 10% or more, freezer performance may be affected. Operating freezer with insufficient power can damage the motor. Such damage is not covered under the warranty. If you suspect your household voltage is high or low, consult your power company for testing.
- To prevent the freezer from being turned off accidentally, do not plug unit into an outlet controlled by a wall switch or pull cord.
- Do not pinch, knot, or bend the cord in any manner.

OTHER PRECAUTIONS

- Never unplug the freezer by pulling on the cord. Always grip the plug firmly, and pull straight out from the receptacle.

NOTE: Turning the temperature control to OFF turns off the compressor, but does not disconnect the power to the light bulb or other electrical components.

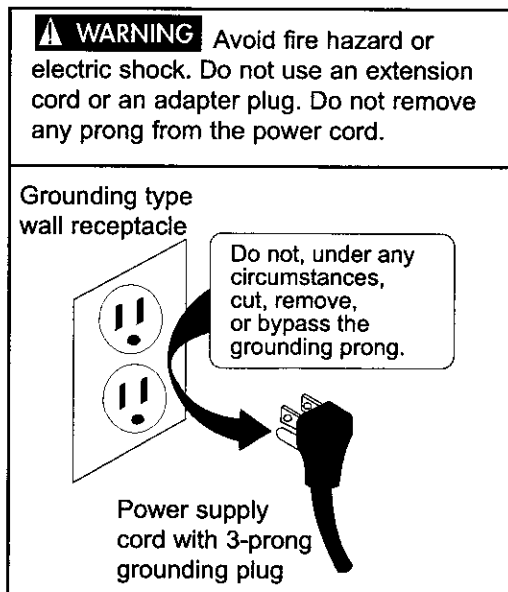

FREEZER WARRANTY

FULL ONE-YEAR WARRANTY ON FREEZER

For one year from the date of purchase, when this freezer is operated and maintained according to the instructions provided in this Owner's Guide, Sears will repair this freezer, free of charge, if defective in material or workmanship.

FULL FIVE-YEAR WARRANTY ON SEALED REFRIGERATION SYSTEM

For five years from the date of purchase, when this freezer is operated and maintained according to the instructions provided in this Owner's Guide, Sears will repair the sealed system (consisting of refrigerant, connecting tube, and compressor), free of charge, if defective in material or workmanship.

The above freezer warranty applies only to freezers which are used for storage of food for private household purposes.

FOOD LOSS COVERAGE LIMITATION

If promptly reported to your nearest Sears store or Service Center, Sears will reimburse you up to a total of \$100.00 for the value of food, as verified by Sears, lost while stored in the freezer when used for private household purposes as a result of:

1. Defects that occur during the first year following the date of purchase.
2. Failure of the sealed refrigeration system (including refrigerant, connecting tube, and compressor), due to defects that occur during the second through fifth year after purchase. If freezer is used for other than private household purposes, Sears will not be responsible for any food loss. Food losses resulting from other than the above stated defects, such as natural spoilage, power interruption, inadequate power, manual disconnect of power supply, fire damage, water damage, theft, etc., are beyond our control and are not covered by Sears. Some states do not allow the exclusion or limitation of incidental or consequential damages, so the above limitation or exclusion may not apply to you. This warranty gives you specific legal rights, and you may have other rights which vary from state to state.

Warranty service is available by contacting the **NEAREST SEARS SERVICE CENTER (1-800-4-MY-HOME®)** in the United States. See the back page of this manual.

Sears, Roebuck and Co.
Dept. 817WA
Hoffman Estates, IL 60179

CANADA – LIMITED WARRANTY



Freezers

Sears Canada Inc., warrants every new *Kenmore*® freezer to be free from defects in materials or workmanship. This is what Sears will do, free of charge, in case of defect.

What is covered?	How long warranted? (from date of sale)	Parts: At Sears option either repair or supply replacement part for:	Labor: Install repaired or replacement part for:
The Compressor	FIVE (5) YEARS	FIVE (5) YEARS	FIVE (5) YEARS
The Sealed System (consisting of refrigerant, evaporator and condenser)	FIVE (5) YEARS	FIVE (5) YEARS	FIVE (5) YEARS
All other parts or adjustments	ONE (1) YEAR	ONE (1) YEAR	ONE (1) YEAR

Normal Responsibilities of the Customer

The following items, since they are not manufacturing defects, are not included in the warranty, but are the responsibility of the customer:

- 1) Damage to finish after delivery.
- 2) Improper power supply, low voltage, or any defects in the house wiring system or appliance not connected to electric outlet.
- 3) Replacement of light bulbs.
- 4) Damage caused by moving the product from its original installation.
- 5) Service required as a result of alteration, abuse, fire, floods, or acts of God.
- 6) Providing adequate air circulation to the refrigerating system.
- 7) Proper use and care of product as listed in the customer's manual; proper setting of the controls.

If any service is required under this warranty, simply call **1-800-4-MY-HOME**® (1-800-469-4663).

This warranty is in addition to any statutory warranty. The above warranty covers *Kenmore* Freezers sold and operated in Canada only and shall not apply if the freezer is used for other than domestic purposes.

Sears Maintenance Agreement

Maintain the value of your *Kenmore* freezer with a Sears Maintenance Agreement.

Sears Canada Inc. • Toronto, Canada • M5B 2B8



FIRST STEPS

This Owner's Guide provides specific operating instructions for your model. Use the freezer only as instructed in this Owner's Guide. **Before starting the freezer, follow these important first steps.**

INSTALLATION

- Choose a place that is near a grounded electrical outlet. **Do Not** use an extension cord or an adapter plug.
- For the most efficient operation, the freezer should be located where surrounding temperatures will not exceed 100°F (37.7°C). Temperatures below 32°F (0°C) will affect freezer operation. Additional compressor heaters are not recommended. This freezer is not recommended for use in locations that will fall below 32°F.
- *Allow space around the unit for good air circulation.* Leave a 4 inch (102 mm) space on all sides of the freezer for adequate circulation.

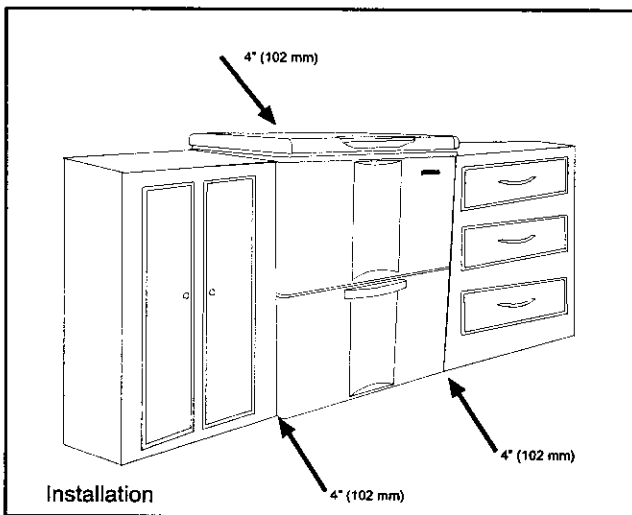

NOTE: The exterior walls of the freezer may become quite warm as the compressor works to transfer heat from the inside. Temperatures as much as 30°F warmer than room temperature can be expected. For this reason it is particularly important in hotter climates to allow enough space for air circulation around your freezer.

NOTE: If the freezer has been placed on its side or in a tilted position for any period of time, wait 24 hours before plugging it in.

CLEANING

- Wash any removable parts, the freezer interior, and exterior with mild detergent and warm water. Wipe dry. **Do not use harsh cleaners on these surfaces.**
- Do not use razor blades or other sharp instruments, which can scratch the appliance surface when removing adhesive labels. Any glue left from the tape can be removed with a mixture of warm water and mild detergent, or touch the residue with the sticky side of tape already removed. **Do not remove the serial plate.**

ENERGY SAVING TIPS



- The freezer should be located in the coolest area of the room, away from heat producing appliances or heating ducts, and out of direct sunlight.
- Let hot foods cool to room temperature before placing in the freezer. Overloading the freezer forces the compressor to run longer. Foods that freeze too slowly may lose quality or spoil.
- Be sure to wrap foods properly, and wipe containers dry before placing them in the freezer. This cuts down on frost build-up inside the freezer.
- Freezer shelves should not be lined with aluminum foil, wax paper, or paper toweling. Liners interfere with cold air circulation, making the freezer less efficient.
- Organize and label food to reduce door openings and extended searches. Remove as many items as needed at one time, and close the door as soon as possible.

SETTING THE TEMPERATURE CONTROL

COOL DOWN PERIOD

- For safe food storage, allow 4 hours after starting operation for the freezer to cool down completely. The freezer will run continuously for the first several hours. Foods that are already frozen may be placed in the freezer after the first few hours of operation. Unfrozen foods should NOT be loaded into the freezer until the freezer has operated for 4 hours.
- When loading the freezer, freeze only 3 pounds of fresh food per cubic foot of freezer space at one time. Distribute packages to be frozen evenly throughout the freezer. It is not necessary to turn the control knob to a colder setting while freezing food.

TEMPERATURE CONTROL

The temperature control is located on the right exterior wall. The temperature control is adjustable to provide a range of temperatures for your personal satisfaction. The freezer has 6 temperature settings. If a colder temperature is desired, turn the temperature control knob toward setting #6 and allow several hours for temperatures to stabilize between adjustments.

- The Access Plus™ is a uniquely designed chest freezer with a separate drawer. The 2 food compartments, in addition to the storage basket, are the ultimate in food storage organization.
- Vegetable bags are easily accessible from the food basket. Meats can be stored in the upper compartment, which is cooler than the bottom drawer. Soft foods such as breakfast waffles, frozen boxed sausages, ice creams, etc., are perfect for the bottom drawer.

NOTE: Recommend starting at setting #4 and adjust accordingly.

NOTE: Temperatures will be affected by the settings, by the surrounding temperature and by the amount of food in the freezer.

FREEZER FEATURES

POWER ON LIGHT

The green *Power On* light indicates that the freezer is properly connected to electrical power. The light glows even when the temperature control is turned to OFF. If the light goes out, refer to the *Freezer Does Not Run* Section in the **Troubleshooting Guide**. If the freezer appears to be operating, the light element might be burned out. Call 1-800-4-MY-HOME® for replacement.

SLIDE-ASIDE BASKET

This basket helps organize odd-shaped items. To reach other packages in the freezer, slide the basket aside, or lift out.

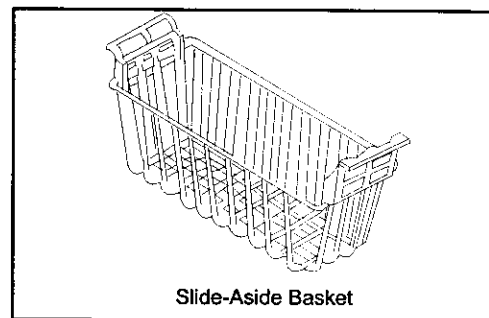

FAST-FREEZE

The Access Plus™ freezer is equipped with a Fast-Freeze feature. This feature will activate the compressor and keep the freezer running continuously, driving the freezer to its coldest possible temperature. Use this feature just prior to adding large quantities of unfrozen foods.

The Fast-Freeze switch is located by the temperature control on the right exterior wall. Press the orange switch to activate. Indicator light turns on when activated. Turn off the Fast Freeze feature once food has reached desired temperature.

CASTERS

Freezer comes with casters for easy mobility. Install the casters on the 4 bottom corners. Slide caster in the provided slot. Once the caster is in place, secure it with a provided screw.

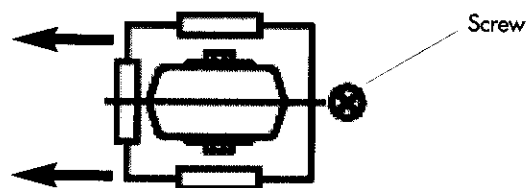

NOTE: Phillips Head screwdriver required.

CARE AND CLEANING

⚠ WARNING Damp objects stick to cold metal surfaces. Do not touch interior metal surfaces with wet or damp hands.

BETWEEN DEFROSTING

To avoid frequent defrosting, occasionally use a plastic scraper to remove frost. Scrape with a pulling motion. Never use a metal instrument to remove frost.

DEFROSTING

It is important to defrost and clean the freezer when 1/4 to 1/2 inch of frost has accumulated. Frost may tend to accumulate faster on the upper part of the freezer due to warm, moist air entering the freezer when the door is opened. Remove food and leave the door open when defrosting the freezer.

If the frost is soft, remove it by using a plastic scraper. If the frost is glazed and hard, fill deep pans with hot water and place them on the freezer bottom. Close the freezer door. Frost should soften in about 15 minutes. Repeat this procedure if necessary.

CLEANING THE INSIDE

After defrosting, wash inside surfaces of the freezer with a solution of two tablespoons of baking soda in one quart (1.136 liters) warm water. Rinse and dry. Wring excess water out of the sponge or cloth when cleaning in the area of the controls, or any electrical parts.

Wash the removable parts and door basket with the baking soda solution mentioned above, or mild detergent and warm water. Rinse and dry. **Never** use metallic scouring pads, brushes, abrasive, cleaners, or alkaline solutions on any surface. Do not wash removable parts in a dishwasher.

CLEANING THE OUTSIDE

Wash the cabinet with warm water and mild liquid detergent. Rinse well and wipe dry with a clean soft cloth. Replace parts and food.

⚠ DANGER If leaving the freezer door open while on vacation, make certain that children cannot get into the freezer and become entrapped which will lead to suffocation and death.

VACATION AND MOVING TIPS

Short Vacations:

Leave the freezer operating during vacations of less than three weeks.

Long Vacations:

If the freezer will not be used for several months:

- Remove all food and unplug the power cord.
- Clean and dry the interior thoroughly.
- Leave the freezer door open slightly, blocking it open if necessary, to prevent odor and mold growth.

Moving:

When moving the freezer, follow these guidelines to prevent damage.

- Disconnect the power cord plug from the wall outlet.
- Remove foods, then defrost, and clean the freezer.
- Secure all loose items such as the basket and the bottom drawer by taping them securely in place to prevent damage.
- In the moving vehicle, secure freezer in an upright position to prevent movement. Also protect outside of freezer with a blanket, or similar item.

POWER FAILURE/FREEZER FAILURE

NOTE: Do not open freezer door unnecessarily if freezer is off for several hours.

If a power failure occurs, frozen foods will stay frozen for at least 24 hours if the freezer is kept closed. If the power failure continues, pack seven or eight pounds of dry ice in the freezer every 24 hours. Look in the Yellow Pages under *Dry Ice* or *Ice Cream Manufacturers* for local dry ice suppliers. Always wear gloves and use caution when handling dry ice.

If the freezer has stopped operating, see *Freezer Does Not Run* in the **Troubleshooting Guide**. If you cannot solve the problem, call 1-800-4-MY-HOME® immediately to schedule a service appointment.

If the freezer remains off for several hours, follow the directions above for the use of dry ice during a power failure. If necessary, take the food to a local locker plant until the freezer is ready to operate. Look in the Yellow Pages under *Frozen Food Locker Plants*.

TROUBLESHOOTING GUIDE		
Before calling for service, review this list. It may save you time and expense. This list includes common occurrences that are not the result of defective workmanship or materials in this appliance.		
PROBLEM	CAUSE	CORRECTION
FREEZER DOES NOT RUN		
Freezer does not run.	<ul style="list-style-type: none"> • Freezer is plugged into a circuit that has a ground fault interrupt. • Temperature control is in the OFF position. • Freezer may not be plugged in, or plug may be loose. • House fuse blown or tripped circuit breaker. • Power outage. 	<ul style="list-style-type: none"> • Use another circuit. If you are unsure about the outlet, have it checked by a certified technician. • See Setting the Temperature Control Section. • Ensure plug is tightly pushed into outlet. • Check/replace fuse with a 15 amp time delay fuse. Reset circuit breaker. • Check house lights. Call local Electric Company.
Freezer runs too much or too long.	<ul style="list-style-type: none"> • Room or outside weather is hot. • Freezer has recently been disconnected for a period of time. • Large amounts of warm or hot food have been stored recently. • Doors are opened too frequently or too long. • Freezer door may be slightly open. • Temperature Control is set too low. • Freezer gasket is dirty, worn, cracked, or poorly fitted. 	<ul style="list-style-type: none"> • It's normal for the freezer to work harder under these conditions. • It takes 4 hours for the freezer to cool down completely. • Warm food will cause freezer to run more until the desired temperature is reached. • Warm air entering the freezer causes it to run more. Open doors less often. • See "DOOR PROBLEMS" Section of this Troubleshooting Guide. • Turn control knob to a warmer setting. Allow several hours for the temperature to stabilize. • Clean or change gasket. Leaks in the door seal will cause freezer to run longer in order to maintain desired temperature.
Interior Freezer temperature is too cold.	<ul style="list-style-type: none"> • Temperature Control is set too low. 	<ul style="list-style-type: none"> • Turn the control to a warmer setting. Allow several hours for the temperature to stabilize.
Interior Freezer temperature is too warm.	<ul style="list-style-type: none"> • Temperature Control is set too warm. • Door is kept open too long or is opened too frequently. • Door may not be seating properly. • Large amounts of warm or hot food may have been stored recently. • Freezer has recently been disconnected for a period of time. 	<ul style="list-style-type: none"> • Turn control to a colder setting. Allow several hours for the temperature to stabilize. • Warm air enters the freezer every time the door is opened. Open the door less often. • See "DOOR PROBLEMS" Section of this Troubleshooting Guide. • Wait until the freezer has had a chance to reach its selected temperature. • Freezer requires 4 hours to cool down completely.
Freezer external surface temperature is warm.	<ul style="list-style-type: none"> • The external freezer walls can be as much as 30°F warmer than room temperature. 	<ul style="list-style-type: none"> • This is normal while the compressor works to transfer heat from inside the freezer cabinet.

PROBLEM	CAUSE	CORRECTION
SOUND AND NOISE		
Popping or cracking sound when compressor comes on.	<ul style="list-style-type: none"> • Metal parts undergo expansion and contraction, as in hot water pipes. 	<ul style="list-style-type: none"> • This is normal. Sound will level off or disappear as freezer continues to run.
Bubbling or gurgling sound, like boiling water.	<ul style="list-style-type: none"> • Refrigerant (used to cool freezer) is circulating throughout the system. 	<ul style="list-style-type: none"> • This is normal.
Vibrating or rattling noise.	<ul style="list-style-type: none"> • Floor is uneven or weak. Freezer rocks on floor when it is moved slightly. • Freezer is touching the wall. 	<ul style="list-style-type: none"> • Ensure floor can adequately support freezer. Level the freezer by putting wood or metal shims under part of the freezer. • Move freezer slightly away from the wall.
WATER/MOISTURE/FROST INSIDE FREEZER		
Moisture forms on inside freezer walls.	<ul style="list-style-type: none"> • Weather is hot and humid, which increases internal rate of frost build-up. • Door may not be seating properly. • Door is kept open too long, or is opened too frequently. 	<ul style="list-style-type: none"> • This is normal. • See “DOOR PROBLEMS” Section of this Trouble Shooting Guide. • Open the door less often.
WATER/MOISTURE/FROST OUTSIDE FREEZER		
Moisture forms on outside of freezer.	<ul style="list-style-type: none"> • Door may not be seating properly, causing the cold air from inside the freezer to meet warm moist air from outside. 	<ul style="list-style-type: none"> • See “DOOR PROBLEMS” Section of this Trouble Shooting Guide.
ODOR IN FREEZER		
Odor in freezer.	<ul style="list-style-type: none"> • Interior needs to be cleaned. • Foods with strong odors are in freezer. 	<ul style="list-style-type: none"> • Clean interior with sponge, warm water, and baking soda. • Cover the food tightly.
DOOR PROBLEMS		
Door will not close.	<ul style="list-style-type: none"> • Floor is uneven or weak. Freezer rocks on floor when it is moved slightly. 	<ul style="list-style-type: none"> • Level the floor by using wood or metal shims under the freezer or brace floor supporting the freezer.