

## CBS-1261 and CBS-1262 Extractor Plus Brewing System FETCO PLUS® Commercial Beverage Equipment



CBS-1261 Single 3 gallon brewer and CBS-1262 Dual 3 gallon Extractor Plus Brewers shown with FETCO 3 Gallon TPD-30 dispensers (sold separately)



### CONTACT INFORMATION

FETCO® FOOD EQUIPMENT TECHNOLOGIES COMPANY  
600 ROSE ROAD  
LAKE ZURICH • IL • 60047-0429 • USA  
ON THE WEB: [fetco.coffee](http://fetco.coffee)  
©2020-2021 FETCO  
PATENTS: <https://www.fetco.com/pl/pages/patents,74.html>



[fetco.com](http://fetco.com)

PHONE: (800) 338-2699 (US & CANADA)  
(847) 719-3000 (All Countries)  
FAX: (847) 719-3001  
EMAIL: [sales@fetco.com](mailto:sales@fetco.com)  
[orders@fetco.com](mailto:orders@fetco.com) (to order parts and equipment)  
[techsupport@fetco.com](mailto:techsupport@fetco.com) (all service queries)

P214 September 2024

### Coffee Brewer: CBS-1260 series

### TABLE OF CONTENTS

Electrical Configurations .....	3	F Service Menu .....	14
Programing Menu Layout .....	6	F Error Codes .....	15
A Program .....	8	G Counters .....	16
B General .....	9	Operator Training .....	18
C Service Inputs .....	10	Modular Brew Head and Bypass Valves .....	29
D Service Outputs .....	11	Wiring Diagrams .....	30
E Calibration .....	12		

Specifications and Requirements

**Water Requirements:**

CBS-1261 & CBS1262  
20-75 psig, (138-517kPa) 1½gpm/(5.7lpm)

**Water inlet fitting** is a 3/8 inch male flare.  
Brewer supplied with inlet valve adaptor for BSP to SAE

**CBS-2161 and CBS-2162**

**Brew Volume: First Batch 3 gallons/ 12 liters**  
**Second Batch 1½ gallons/ 6 liters**

**Electrical:**

See electrical configuration charts. All CBS-1260 series brewers use a terminal block for electrical connection

**Tank Temperature, as set by factory:**  
200°F (93°C) inside water tank (at sea level)

**Water supply: (Optimal) 100-150TDS**  
All beverage equipment must use filtered water.

Brew Capacity CBS-1261 5-8 brews per hour  
(approximate) CBS-1262 5-20 brews per hour

Output is controlled by heater power and water temperature

**CBS-1261 & CBS-1262 Total Brew Cycle—Factory Default Settings**

First batch-large: 3 gal. (12 lit.) 7½ minutes comprising 6 min. brew time & 1.5 min. drip delay. Bypass factory set at 20%  
Second batch- half: 1½ gal. (6 lit.) 6½ minutes comprising 5 min. brew time & 1.5 min. drip delay. Bypass set at 10%  
Third batch- not set by factory and is configurable by user

**Individual menu brew-process parameters are user controllable for:**

Basic user controls for brew volume, brew time, units of measure, recipe name, activating third batch  
Advanced user controls for pulse count, prewet percent and prewet delay, drip delay, programmable energy saving

**Brew-Process parameters are user controllable for:**

Basic user controls for brew volume, brew time, units of measure, recipe name, activating third batch  
Advanced user controls for pulse count, prewet percent and prewet delay, drip delay, programmable energy saving

Weights and Capacities

Model	Height	Width	Depth	Water tank capacity	Empty Weight	Filled Weight	Shipping Weight	Shipping Dimensions
CBS-1261 3 gal	41.38" 105.11 cm	17.88" 45.42 cm	27.50" 69.85 cm	8.6 gallon 33 L	88 lbs 39.9 kg	160 lbs 72.6 kg	97 lbs 44.0 kg	39" x 23" x 28" 99 x 58.4 x 71.7 cm
CBS-1262 3 gal	41.38" 105.11 cm	32.0" 81.28 cm	27.50" 69.85 cm	15.9 gallon 60 L	130 lbs 59.0 kg	266 lbs 120.7 kg	140 lbs 63.5 kg	39" x 37" x 29" 99 x 94 x 73.7 cm

Rough-In Drawings

1201.00063.00 (CBS-1262) 1201.00062.00 (CBS-1261)

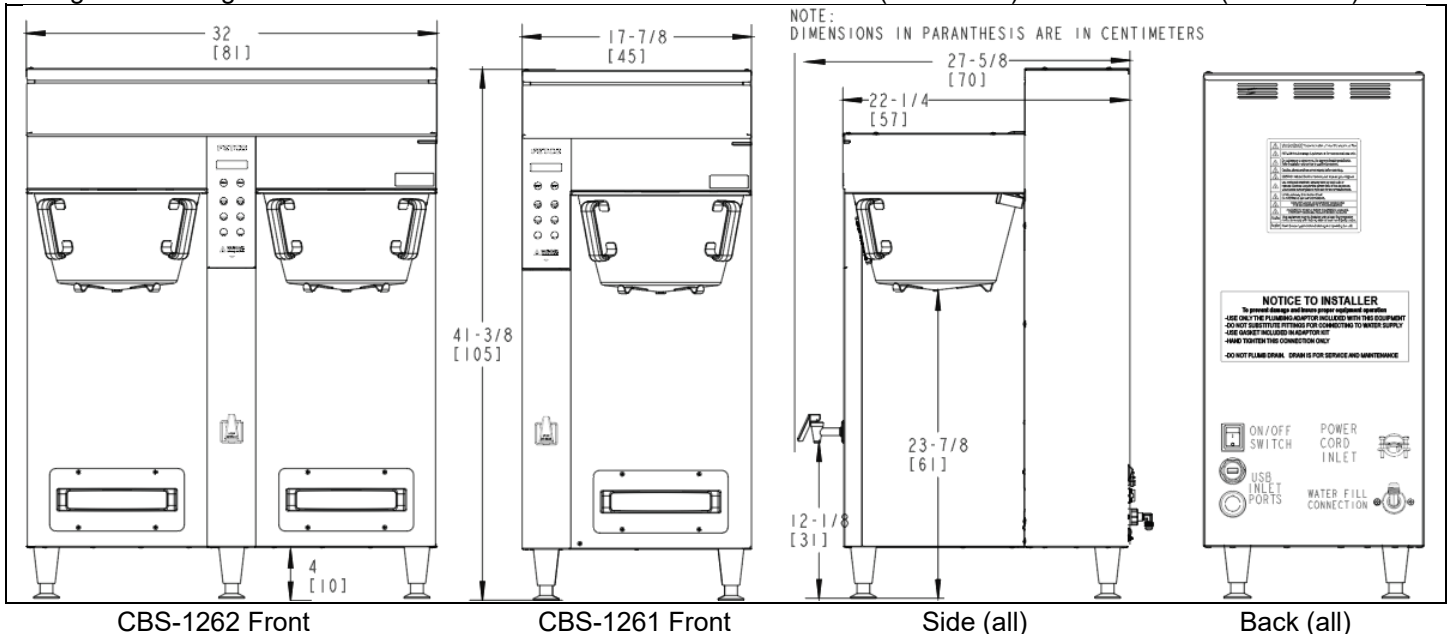

EXAMPLE: SKU E1261US-UB230-MM110												
SKU NUMBER IDENTIFICATION KEY												
E												
Product Line	Level	Family	Region ID	Phase	Voltage Range	# Heaters	Individual Heater Wattage	Brew Basket	Hot Water Faucet	Bypass	Brew Basket Locks	Power Cord
E=extractor	12=PLUS Series	61= single side	US =United States	1	A = 100-120	1	1.5	M=metal	M=manual	1=Yes	1=Yes	0=Terminal Block
M=Multi (Coffee TEA)	22= Next Generation	62= dual side	IN = International	2	B = 200-240	2	1.7		A=automatic	0=no	0=no	
			CE = CE	3	C = 380-415	3	2.3		N=None			
			NM = NOM	U = 1 or 3 phase	D = 440-480	6	3.0					
			KSA=Saudi Arabia				4.0					
			BR=Brazil				5.0					

## Electrical Configurations

### Electrical Configurations CBS-1261 Single Side *Plus* 3 gallon brewer

<b>CBS-1261 Single 3 gallon-6 Liter Brewer:</b> Field configurable USA and Canada models with cUL/UL & NSF-4 certification <b>Electrical and Output Specifications</b> All brewers use terminal block for electrical connection Professional installation is required Field configurable brewers are shipped from factory in single phase configuration. Instructions are provided for licensed installer to configure wiring at terminal block to three phase							
Configuration Codes	Heater Configuration	Voltage	Phase	Wires	KW	Amp Draw	Brew Volume/Hour
E1261US-UB230-MM110 Selectable (1 or 3 phase) Sold as single phase(see pg.29)	2 X 3.0 kW	208-240	1	2+G	4.5-6.0	22.2-25.5	15.9 gal/60.4 L
	3 X 3.0 kW	208-240	3	3+G	6.8-9.0	19.3-22.2	23.9 gal/90.6L
E1261JP-UB230-MM110 Selectable (1 or 3 phase) Sold as single phase(see pg.29)	2 X 3.0 kW	200-240	1	2+G	4.5-6.0	21.2-25.8	15.9 gal/16.4 L
	3 X 3.0 kW	200-240	3	3+G	6.8-9.0	18.6-22.5	23.9gal/90.6 L
<b>CBS-1261 Single 3 gallon-6 Liter Brewer:</b> International models with cUL/UL & NSF-4 certification <b>Electrical and Output Specifications</b> All brewers use terminal block electrical for connection Professional installation is required							
Configuration Codes	Heater Configuration	Voltage	Phase	Wires	KW	Amp Draw	Brew Volume/Hour
E1261IN-3C330-MM110	3 X 3.0kW	220/380-240/415	3	3L/N/G	7.6-9.1	11.7-12.7	23.9 gal/90.6 L
E1261IN-3C340-MM110	3 X 4.0kW	220/380-240/415	3	3L/N/G	10.2-12.1	15.5-16.9	30.0 gal/114 L
E1261IN-3C350-MM110	3 X 5.0kW	220/380-240/415	3	3L/N/G	12.7-15.1	19.3-21.0	30.0 gal/114 L
E1261NM-3B350-MM110	3 X 5.0kW	208-240	3	3L/N/G	11.3-15.0	31.8-36.6	30.0 gal/114 L
E1261KS-3C330-MM110	3 X 5.0kW	220/380-240/415	3	3L/N/G	12.7-15.1	19.3-21.0	30.0 gal/114 L
E1261BR-3C350-MM110	3 X 5.0kW	220/380-240/415	3	3L/N/G	12.7-15.1	19.3-21.0	30.0 gal/114 L
<b>CBS-1261<i>Plus</i> Single 3 gallon-6 Liter Coffee Brewers</b> CE listed models with NSF-4 Certification. Internal EMI Filter <b>Electrical and Output Specifications</b> All brewers use terminal block electrical for connection Professional installation is required							
Configuration Codes	Heater Configuration	Voltage	Phase	Wires	KW	Amp Draw	Brew Volume/Hour
E1261CE-3B330-MM110	3 X 3.0kW	230/400	3	3L,N,PE	8.3	12.5	22.1 gal/83.6 L
E1261CE-3B340-MM110	3 X 4.0kW	230/400	3	3L,N,PE	11.0	16.5	29.2 gal/111 L
NOTES: Applies to all equipment on this page -Advanced electronics enable this equipment to operate with a 50-60 Hz frequency range without affecting the circuit or requiring user adjustments. -The "NM" in the SKU suffix denotes equipment with NOM certification, Spanish labeling for Mexico and Spanish language user guide -The "KS" in the SKU suffix indicates GCC equipment with CB Scheme certification, labeling for KSA, and Arabic language user guide. -The "BR" in the SKU suffix indicates Brazil equipment with INMETRO certification, Type N plug, labeling and Portuguese for Brazil language user guide. -The "CE" in the SKU suffix indicates equipment with a current CB scheme supporting 60335 CE marking. This equipment is not cUL/UL certified							

CBS-1262 *Plus* Twin 3 Gallon Coffee Brewers continued following page



## Electrical Configurations CBS-1262 Dual Side *Plus* 3 gallon brewer

**CBS-1262 Dual 3 gallon-6 Liter Brewer:** Domestic and International models. With cUL/UL & NSF-4 Certification  
**Electrical and Output Specifications** All brewers use terminal block electrical connection for 50Hz or 60Hz Professional installation is required.

Configuration Codes	Heater Configuration	Voltage	Phase	Wires	KW	Amp Draw	Brew Volume/Hour
E1262US-3B330-MM110	3 x 3.0 kW	208-240	3	3+G	6.8-9.0	19.3-22.2	23.9 gal/90.6 L
E1262US-3B630-MM110	6 x 3.0 kW	208-240	3	3+G	13.5-18.0	38.0-43.8	47.8 gal/181 L
E1262US-3B340-MM110	3 x 4.0 kW	208-240	3	3+G	9.0-12.0	25.5-29.4	31.9 gal/121 L
E1262US-3B640-MM110	6 x 4.0 kW	208-240	3	3+G	18.1-24.1	50.8-58.5	47.8 gal/181

**CBS-1262 Dual 3 gallon-6 Liter Brewer:** Specialty International With Country Specific & NSF-4 Certification  
**Electrical and Output Specifications** All brewers use terminal block electrical for connection Professional installation is required.

E1262IN-3C350-MM110	3 x 5.0 kW	220/380- 240/415	3	3L/N/G	12.6-15.0	19.6-21.3	39.9 gal/151 L
E1262JP-3B630-MM110	6 x 3.0 kW	200-240	3	3+G	12.6	38.0	32.4 gal/123L
E1262KS-3C630-MM110	6 x 3.0 kW	220/380	3	3L/N/PE	12.6-15.0	19.6-21.3	39.9 gal/151 L
E1262NM-3B630-MM110	6 x 3.0 kW	208-240	3	3+G	13.5-18.0	38.0-43.8	47.8 gal/181 L
E1262NM-3B640-MM110	6 x 4.0 kW	208-240	3	3+G	18.1-24.1	50.8-58.5	47.8 gal/181

**CBS-1262 Dual 3 gallon-6 Liter Brewer:** CE Certified With NSF-4 Certification

**Electrical and Output Specifications** All brewers use terminal block electrical for connection Professional installation is required.

E1262CE-3B340-MM110	3 x 4.0 kW	230/400	3	3L,N,PE	11.0	16.5	29.2 gal/111 L
E1262CE-3B350-MM110	3 x 5.0 kW	230/400	3	3L,N,PE	13.8	20.5	36.7 gal/139 L

NOTES: Applies to all equipment on this page

-Advanced electronics enable this equipment to operate with a 50-60 Hz frequency range without affecting the circuit or requiring user adjustments.

-The "NM" in the SKU suffix denotes equipment with NOM certification, Spanish labeling for Mexico and Spanish language user guide

-The "KS" in the SKU suffix indicates GCC equipment with CB Scheme certification, labeling for KSA, and Arabic language user guide.



-The "BR" in the SKU suffix indicates Brazil equipment with INMETRO certification, Type N plug, labeling and Portuguese for Brazil language user guide.

-The "CE" in the SKU suffix indicates equipment with a current CB scheme supporting 60335 CE marking. This equipment is not cUL/UL certified

EXAMPLE: SKU E1261US-UB330-MM110													SKU NUMBER IDENTIFICATION KEY			
E	12	61	US	U	B	3	30	M	M	1	1	0				
Product Line	Level	Family	Region ID	Phase	Voltage Range	# Heaters	Individual Heater Wattage	Brew Basket	Hot Water Faucet	Bypass	Brew Basket Locks	Power Cord				
E=extractor	12=PLUS Series	61= single side	US =United States	1	A = 100-120	1	1.5kW	M=metal	M=manual	1=Yes	1=Yes	0=Terminal Block				
M=Multi (Coffee TEA) T=TEA	22= Next Generation	62= dual side	IN = International	2	B = 200-240	2	1.7kW		A=automatic	0=no	0=no					
			CE = CE	3	C = 380-415	3	2.3kW		N=None							
			KSA=Saudi Arabia	U = 1 or 3 phase	D = 440-480	6	3.0kW									
			NM = NOM				4.0kW									
			BR=Brazil				5.0kW									

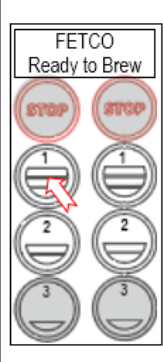

## The Brew Sequence

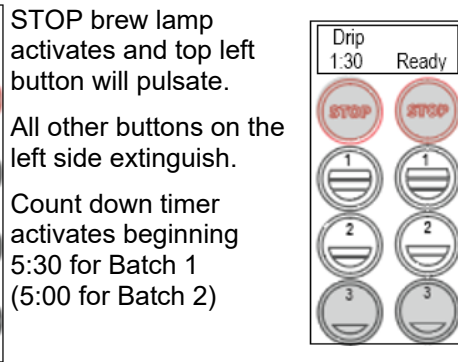
 <p>First screen shows top left brew position being activated ...</p> <p>Right side is in "READY-MODE" during brew, and can be accessed for brewing</p>	 <p>STOP brew lamp activates and top left button will pulsate.</p> <p>All other buttons on the left side extinguish.</p> <p>Count down timer activates beginning 5:30 for Batch 1 (5:00 for Batch 2)</p>	 <p>The brewing cycle completes in four minutes. Stop button extinguishes and drip out starts at 1:30 minutes.</p> <p>Do not remove brew basket during this part of the cycle.</p> <p>Brewer returns to "ready to brew" (screen one) after drip out completes</p>
--	---	---

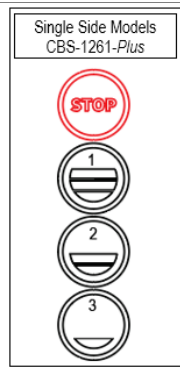
<p><b>RECIPE Location map</b></p> <p>Viewing and changing settings for the brew recipes is from the "A" screens with the controls in PROGRAMMING.</p> <p>The uppermost button positions are permanent and will not display programming step A_0. The table above shows in position A20 that a button position can be made <b>active or inactive</b>. Position A1 does not display this step</p>	<p>Single Side Models CBS-1261-Plus</p> 	<p>←DISPLAY→</p> <p>←STOP→</p> <p>←BATCH A1→ (permanent)</p> <p>←BATCH A2→ (enabled by factory)</p> <p>←BATCH A3→ (disabled by factory)</p>	<p>Dual Side Models CBS-2162-Plus</p> <p>←DISPLAY</p> <p>←STOP</p> <p>←BATCH A4→ (permanent)</p> <p>←BATCH A5→ (enabled by factory)</p> <p>←BATCH A6→ (disabled by factory)</p>
---	---	---	---



The "A" menu is the most accessed menu. It is for programming the batch volumes, setting brewing parameters, enabling or disabling brew buttons. The "A" menu moves through the six positions(CBS-1262-) or three positions(CBS-1261+) by entering the menu and pressing the left stop button. (only the left side is active for programming the CBS-1262+)

**The A menus [A1-3 or A1-6] correspond to batch buttons [3 or 6] on the touch panel**

Access the A menus to PROGRAM & make changes to individual menu recipes. Menu settings can be copied

Menu positions A1 and A4 [top position] are permanent. Menus A2, A3, A5, A6 can be removed by operator if desired

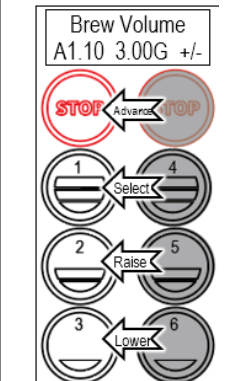
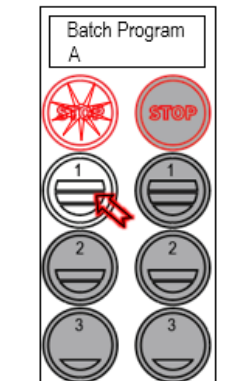
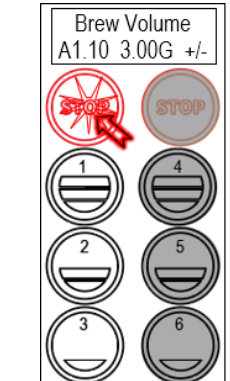
**A1 is top left A4 is top right. A1 & A4 are the only permanent positions and are factory set at 1.5gallons. Both are adjustable.**

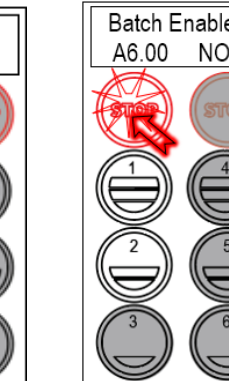
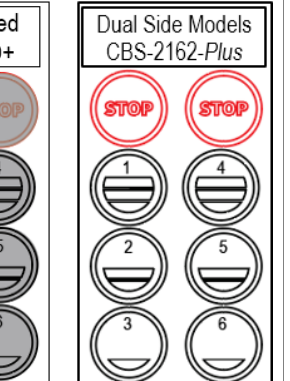
	<p>Batch Program A</p> 	<p>Brew Volume A1.10 3.00G +/-</p> 	<p>Batch Enabled A2.00 YES -</p> 	<p>Batch Enabled A6.00 NO+</p> 	<p>Dual Side Models CBS-2162-Plus</p> 
<p><b>STOP</b>-advances to the next menu programming position (A1 to A9 then to A,B,C,D...)</p> <p><b>BUTTON #1</b>-selects program items in the menu</p> <p><b>BUTTONS 3 &amp; 4</b> raise and lower the selection in the menu</p> <p>Pressing the STOP button advances the next screen A20</p>	<p><b>A PRG screen</b></p> <p>Press button 1 to go into the A menu access screens.</p> <p>Continue pressing button #1 to enter programming for A1</p>	<p><b>A11 screen</b></p> <p>A11 sets the top left side brew button programming. Access brewing parameters by pressing button #1.</p> <p>(Brew Volume, Time, Prewet &amp; Drip Delay)</p>	<p><b>A20 screen</b></p> <p>Press STOP to scroll through the remaining (3 to 6) "A" menus. Make any changes as required</p>	<p><b>A6.00 screen</b></p> <p>Scroll to remaining A10-to A60 programming keys. Changes will be lost unless they are saved in the programming routine.</p> <p>See SAVE &amp; EXIT in previous table</p>	<p><b>Single&amp;Twin Brewers</b></p> <p>Position of batch buttons for CBS-1262+</p> <p>The CBS-1261+ single position brewer has one row of buttons</p>

## Enter Programming

- Turn the brewer OFF from the power switch.
- Turn the brewer ON. Brewer will boot up. After 10 seconds the STOP button will illuminate red
- Press and release the STOP button when it illuminates (red LED)

First stage of the Programming Menu will be in A-10 Batch Parameters. This is the most common programming.

Screens shown are for twin brewer. Single brewer will not have menu A4-A6.

There are seven menu groups-A-G. See the following pages for the batch parameter definitions and all settings for the brewer

### TO ENTER PROGRAMMING

- 1-Turn brewer "OFF" from power switch
  - 2-Turn power switch to "ON"
- ...Screen will initialize and then display digital process notifications
- 3-After Initialization-Red "STOP" Lamp turns on
  - 4-Quickly press "STOP" button.

When brewer is In PROGRAMMING MODE  
-the screen will display:

**BATCH PRG!**  
**A (or B-H)**

-Illuminated LED indicates active keypad positions

See the following pages for batch parameter definitions and all settings for the brewer

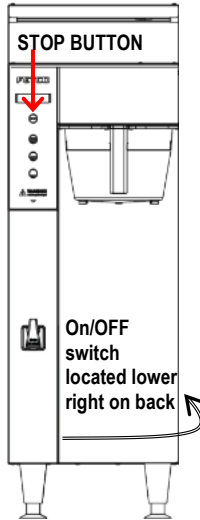

Turn power OFF  
Turn power ON  
Wait for red LED  
And quickly press STOP  
button on front touch pane

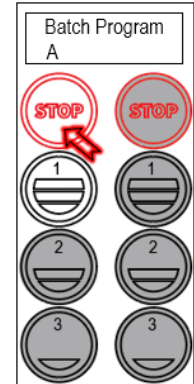

First screen will display for PROGRAMMING-A  
Scroll through main menu topics by pressing "STOP" button.

**Note:** Only the left side buttons of a two sided brewer are used for programming

## Programing Menu Layout

A10 to A70	B10-B40	C10-C50	D10-D90	E10-E70	F10-F120	G1-G15	H10-H11
Batch Parameters	General Settings	Service Inputs	Service Outputs	Calibration	Service Menu	Counters	Exit and Save
A11 Brew Volume	B1 Tank Temperature	C1 LLC Probe	D1 Heater SSR	E1 Ready Temp. Offset	F1 Firmware Ver.	G1 Filter Used	H1 Save Changes
A12 Brew Time	B2 Brew at Temp	C2 Basket Sensor	D2 Fill Valve	E2 LLC Sensitivity	F2 Bootloader Ver.	G2 Filter Life	H2 EXIT?
A13 Prewet Percent	B4 Show Tank Temp	C4 Tank Temperature	D3 Lt Brew Valve	E3 Slow Flow Compensate	F3 Select Model	G3 Filter Reset	
A14 Prewet Delay	B5 Units of Temp	C5 USB Drive	D4 Rt Brew Valve	E4 Lt Brew Flow	F4 Option Bypass	G4 Counter Reset	
A15 Bypass Percent	B6 Units of Volume	C6 Keyboard Test	D5 Lt Bypass Valve	E5 Rt Brew Flow	F5 Option BB Lock	G5 Choose Counter	
A16 Drip Delay	B7 Customer Name		D6 Rt Bypass Valve	E6 Lt Bypass Flow	F8 Backup to USB	G10 Brewer Volume [T]	
A20 Batch (2) Enabled	B8 Customers Name		D7 Lt Basket Lock	E7 Rt Bypass Flow	F9 Restore from USB	G11 Brewer Volume	
A21 Brew Volume	B9 Demo Mode		D8 Rt Basket Lock	E10 Calibration Procedure	F10 Restore Defaults	G12 LT Brews[T]	
A22 Brew Time	B10 Eco Mode		D12 LCD Brightness %		F11 Error Log	G13 LT Brews	
A23 Prewet Percent	B11 Eco Idle Time		D13 LED Brightness %		F12 Erase Error Log	G14 Rt Brews [T]	
A24 Prewet Delay	B12 Eco Idle Temp				F13 Service Phone#	G15 Rt Brews	
A25 Bypass Percent	B13 Water Filter				F14 Override Lt BBS	See page 12	
A26 Drip Delay					F15 Override Rt BBS		
A30 Batch (3) Enabled					F16 Override Lt BBL		
A90 Copy Batch					F17 Override Rt BBL		
A91 Copy Batch: From							
A92 PASTE: To							

Top and middle batches are permanent SEE BOX on the following page for all "A" menus

## The Brew Sequence

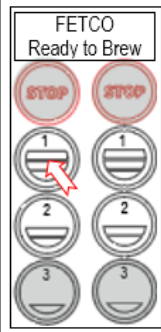

First screen shows top left brew position being activated ...

Right side is in "READY-MODE" during brew, and can be accessed for brewing



STOP brew lamp activates and top left button will pulsate.

All other buttons on the left side extinguish.

Count down timer activates beginning 5:30 for Batch 1 (5:00 for Batch 2)

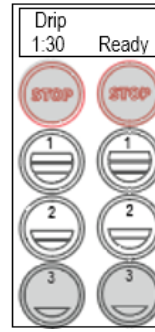

The brewing cycle completes in four minutes. Stop button extinguishes and drip out starts at 1:30 minutes.

Do not remove brew basket during this part of the cycle.

Brewer returns to "ready to brew" (screen one) after drip out completes

### RECIPE Location map

Viewing and changing settings for the brew recipes is from the "A" screens with the controls in PROGRAMMING.

The uppermost button positions are permanent and will not display programming step A\_0. The table above shows in position A20 that a button position can be made **active or inactive**.

Position A1 does not display this step

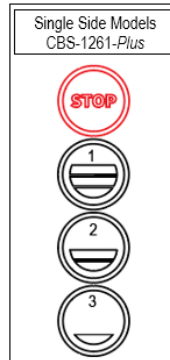

←DISPLAY→

←STOP→

←BATCH A1→  
(permanent)

←BATCH A2→  
(enabled by factory)

←BATCH A3→  
(disabled by factory)

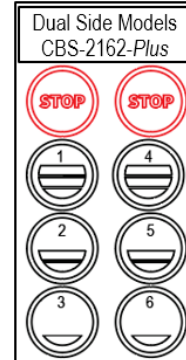

←DISPLAY

←STOP

←BATCH A4  
(permanent)

←BATCH A5  
(enabled by factory)

←BATCH A6  
(disabled by factory)

The "A" menu is the most accessed menu. It is for programming the batch volumes, setting brewing parameters, enabling or disabling brew buttons. The "A" menu moves through the six positions(CBS-1262-) or three positions(CBS-1261+) by entering the menu and pressing the left stop button. (only the left side is active for programming the CBS-1262+)

### The A menus [A1-3 or A1-6] correspond to batch buttons [3 or 6] on the touch panel

Access the A menus to PROGRAM & make changes to individual menu recipes. Menu settings can be copied

Menu positions A1 and A4 [top position] are permanent. Menus A2, A3, A5, A6 can be removed by operator if desired  
**A1 is top left A4 is top right. A1 & A4 are the only permanent positions and are factory set at 1.5gallons. Both are adjustable.**

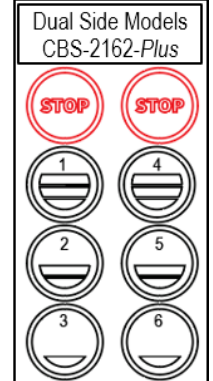
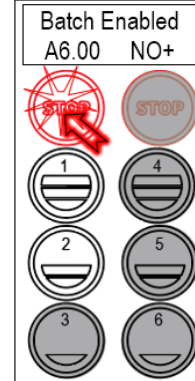
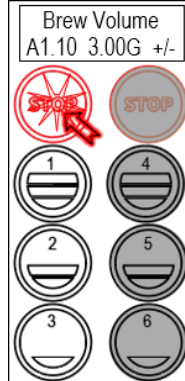
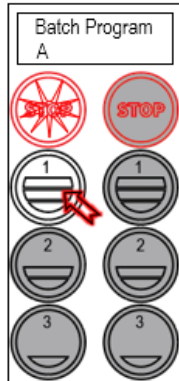
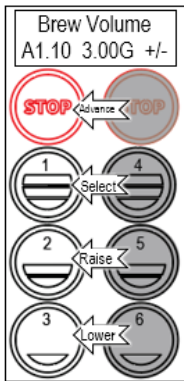

**STOP**-advances to the next menu programming position (A1 to A9 then to A.B.C.D...)

**BUTTON #1**-selects program items in the menu

**BUTTONS 3 & 4** raise and lower the selection in the menu

Pressing the STOP button advances the next screen A20

**A PRG screen**  
Press button 1 to go into to the A menu access screens.

Continue pressing button #1 to enter programming for A1

**A11 screen**  
A11 sets the top left side brew button programming. Access brewing parameters by pressing button #1.  
(Brew Volume, Time, Prewet & Drip Delay)

**A20 screen**  
Press STOP to scroll through the remaining (3 to 6) "A" menus. Make any changes as required

**A6.00 screen**  
Scroll to remaining A10-to A60 programming keys. Changes will be lost unless they are saved in the programming routine.

See SAVE & EXIT in previous table

**Single&Twin Brewers**  
Position of batch buttons for CBS-1262+

The CBS-1261+ single position brewer has one row of buttons

A Program		Menu Features: Batch Parameters			
The settings below are shown for the top batch on a single brewer top left button on a twin brewer. See how to access all A menus on the previous page. Below are the brew settings for default A1 & A2 batches					
POSITION	Program Items	Factory set Default	Programming Range	Increments	Notes
A1.10	Batch Volume	3.0 gal (factory) 11.35 liters 384 U.S. ounces	0.51 to 4.22 gal 1.90 to 16 L 65 to 541 Oz	0.01G 0.05L 1 Oz	Full Batch-3.0 gallons
A1.20	Brew Time	6:00 minutes	2:00 – 12:00	0.30	Default total brew time is 7:30 minutes
A1.30	Prewet Perc.	0%	0.00 – 25.0%	1%	Percentage of total brew volume
A1.40	Prewet Delay (Pause after prewet completes)	0% [1:00 Min]	[0:10 – 5:00]	1:00 min	The time between prewetting and start of brew cycle. <b>This feature appears ONLY if Prewet &gt;0:00</b>
A1.50	Bypass Percent	Batch 1 Full:20% (77 ounces bypassed)	0% – 40%	1%	Diverts brewing water from brew process
A1.60 <b>This is a Safety Feature</b>	Drip Delay	1:30 mm:ss	0:30 – 6:00 Min.		Time that brew basket remains locked during final drip-out →Drip delay remains “ON” for 1:30 minutes if STOP is pressed during brew†
A2.00	BATCH ENABLED	YES (Active)	Middle and Bottom batches A2,3,5,6	Batch on or off	Batches may be individually enabled, rewritten or deactivated
A2.10	Batch Volume	1.5 gal (factory) 6.8 liters 192 ounces	0.51 to 2.00 gal 1.93 to 7.57L	0.01G 0.05L	Half batch of 3.0 gallons
A2.20	Brew Time	5.00 minutes	2:00 – 12:00	0.30	Default total brew time is 6:30 minutes
A2.30	Prewet Perc.	0%	0.00 – 25.0%	1%	Percentage of total brew volume
A2.40	Prewet Delay (Brew pause after prewet completes)	0% [1:00 Min]	[0:10 – 5:00]	1:00 min	The time between prewetting and start of brew cycle. <b>This feature appears ONLY if Prewet &gt;0:00</b>
A2.50	Bypass Percent	Batch 2 Half: 10% (19 ounces bypassed)	0% – 40%	1%	Diverts brewing water from brew process
A2.60 <b>This is a Safety Feature</b>	Drip Delay	1:30 mm:ss	0:30 – 6:00 Min.		Time that brew basket remains locked during final drip-out →Drip delay remains “ON” for 1:30 minutes if STOP is pressed during brew†
A30	Batch Enabled A30 YES - NO +	NO-inactive (defaults to recipe A20 if activated)	Middle and Bottom batches A2,A3	Batch on or off	Batches may be individually enabled, rewritten or deactivated
A90 <b>Batch Copy</b>	Copy From Batch	A90	A90 1 (1-6)		
A91	Copy To Batch?	A91	A91.1 (1-6)		

PULSE BREW note. FETCO CBS-1200V+ brewers are factory programmed to pulse 2 cycles per minute brew time  
Changing the brew time only will increase the pulses but will not change the volume of brew water delivered



B General Brewer Operation Control Settings, Adjust Brew Flow Rate					
POSITION	Program Items	Factory set Default	Programming Range	Increments	Notes
B1	Tank Temp.	200°F-or-93° C NOTE: Equipment is Fahrenheit by default	77° to 97°C 170°F to 207°F	0.5°C 1.0°F	Chart to correct for high altitude below
B2	Brew at Temp.	“YES”	ON/OFF	YES/NO	<b>SEE NOTE BELOW</b>
B4	Show Tank Temperature	YES	YES/NO		To display HW tank temperature on screen
B5	Units of Measure TEMPERATURE	F°-Fahrenheit	Fahrenheit/Celsius	C/F	<b>NOTE:</b> Overwrites user settings (see page 9)
B6	Units of Measure VOLUME	G-Gallons	Gallons/Liters/Ounces	Gal/L/Oz	<b>NOTE:</b> Overwrites user settings (see page 9)
B7	Customer Name	Off	NO or YES		For name on screen
B8	Customer Name	(only if above is “ON)	Scroll with batch keys	A-Z;a-z;0-9	16 characters total
B9	Demo Mode	DEMO ON/OFF			Demonstrates the controls for training. Disables all components in demo mode
B10	Eco Mode	On	ON/OFF	YES/NO	If Selected: Lowers hot water tank temperature after preset time of inactivity
B11	Eco Idle Time	1Hr	1-6 hours	1 hour	Time of inactivity to go into ECO Mode
B12	Eco Idle Temp	170°F	158-176°F	1 degree	Temperature that hot water tank is lowered to
B13	Water Filter	OFF	ON/OFF	YES/NO	Water filter life is accessed in G-Counters. This is user set and will display indicator to change water filter

#### BREW AT TEMPERATURE DEFINITIONS

<b>DEFAULT: BREW AT TEMP: “ON”</b>	
<p><b>(FACTORY DEFAULT FOR BREWER)</b></p> <p>“BREW at TEMP:</p> <p>-Batch will not start if tank temperature is below set point.</p> <p>-Display will show “HEATING” and hot water tank temperature</p> <p>The “BREW START” entry buttons will not illuminate until the hot water tank reaches the selected temperature.</p> <p>Controls allow both sides of dual brewer to operate if one side has an ongoing brew started and the second side brew is selected.</p> <p><b>Notifications shown on screen:</b></p> <p>TEXT: <b>HEATING</b>→Tank above 87°C/189°F-will allow brew at low temperature. Coffee flavor may be affected</p> <p>TEXT: <b>L. HEAT</b>→Tank above 77°C/170°F-will allow brew at low temperature. Coffee flavor will be noticeably affected</p>	<p>Hot water tank not at brew temp setpoint.</p> <p>Tank temp→</p> <p>STOP is not lit →</p> <p>BREW START buttons not lit. and are disabled.</p> <p>When hot water tank temperature is at setpoint. Buttons will illuminate and “READY” will be displayed</p>
<p><b>USER SELECTABLE OPTION: BREW AT TEMP: OFF (Not recommended)</b> Unit will operate at lower temperature</p> <p>Allows brewing at any temperature above 77°C/170°F</p> <p>Below 70°C/170°F The brewer will display “HEATING”</p>	

Chart to correct for altitude for boiling point in tank water temperature.					
[ft]	[m]	Suggested Setting[°F]	Boiling point[°F]	Suggested Setting[°C]	Boiling point [°C]
0	0	205	212.0	96	100.0
500	152	205	211.0	96	99.5
1000	305	200	210.1	93	98.9
2000	610	200	208.1	93	97.8
2500	762	200	207.2	93	97.3
3000	914	200	206.2	93	96.8
3500	1067	197	205.3	92	96.3
4000	1219	195	204.3	91	95.7
4500	1372	194	203.4	90	95.2
5000	1524	194	202.4	90	94.7
5500	1676	193	201.5	89	94.2
6000	1829	192	200.6	89	93.6
6500	1981	191	199.6	88	93.1
7000	2134	190	198.7	87	92.6
7500	2286	188	197.8	86	92.1
8000	2438	187	196.9	86	91.6
8500	2591	185	196.0	85	91.1



C Service Inputs		Brewer Sensors and Keypad			
POSITION	Program Items	Factory set Default	Programming Range	Increments	Notes
C1	LLC Probe continuity	Direct read	Tank water resistance in TDS	≈850- LOW ≈1600-HIGH	Nominal values
C2	Brew Basket Sensor	L-YES R-YES	YES or NO		
C4	Tank Temperature	Direct read	Hot water tank temperature		Actual values
C5	USB Drive	NO	(not in use)		
C6	Keyboard Test	Calibrate	Checks buttons under membrane cover	YES/NO	Follow directions on the touch screen



D Service Outputs		Test Valves and Heaters; Set screen brightness			
POSITION	Program Items	Factory set Default	Programming Range	Increments	Notes
D1	Heater SSR Test	Press button 2 to test (button 1 stops test)	Activates heater Default is 10 sec..	Toggle +/- OFF or ON	Energizes Heater(s) <b>WARNING!</b> Service use only.
D2	Fill Valve Test	Press button 2 to test (button 1 stops test)	Activates valve Default is 10 sec.	Toggle +/- OFF or ON	Press To Test
D3	LT (left) Brew Valve Test	(Press to test)	Activates valve Default is 10 sec.	Toggle +/- OFF or ON	Runs valve to verify flow. NOTE: Have container under brew basket.
D4	RT (right) Brew Valve Test	(Press to test)	Activates valve Default is 10 sec.	Toggle +/- OFF or ON	Runs valve to verify flow. NOTE: Have container under brew basket.
D5	LT (left) Bypass Valve Test	(Press to test)	Activates valve Default is 10 sec.	Toggle +/- OFF or ON	Runs valve to verify flow. NOTE: Have container under brew basket.
D6	RT (right) Brew Valve Test	(Press to test)	Activates valve Default is 10 sec.	Toggle +/- OFF or ON	Runs valve to verify flow. NOTE: Have container under brew basket.
D7	LT (left) Brew Basket Lock Test	(Press to test)	Activates Brew Basket Lock	Toggle +/- OFF or ON	Press To Test
D8	RT (right) Brew Basket Lock Test	(Press to test)	Activates Brew Basket Lock	Toggle +/- OFF or ON	Press To Test
Single series displays right side only Left Valve display is only for twin side brewer.					
D12	LCD Brightness	Brightness=90%	20-100%	5%	Adjust LCD screen brightness only-Not for LEDs under buttons
D13	LED Brightness	Brightness=60%	20-100%	5%	Adjust LED button brightness only-Not for the screen display LCD



E Calibration		Brewer Sensors and Keypad			
POSITION	Program Items	Factory set Default	Programming Range	Increments	Notes
E1	Ready Temp. Offset	-3°F -2°C	-2° to -9°F -1° to -5° C	1°F 1°C	Compensates output to measured temperature
E2	LLC Sensitivity	NORMAL ("NORMAL" for most water)	HIGH (Biased for reverse osmosis water or very pure water)	NORMAL HIGH	Liquid level control sensitivity. High, 1300Ω is for reverse osmosis water or very pure water.
E3	Slow flow rate from supply	OFF	OFF/ON	Toggle +/- YES or NO	Trims fill system for reverse osmosis, low supply or Flojet use
E4	LT Brew Valve flow rate:	1.05 G 3.95 L 134 Oz	0.89-1.22G 3.35-4.65Liter 114-157 Oz	0.01G 0.05L 1 Oz	Adjusts flow rate
E5	RT Brew Valve flow rate:	1.05 G 3.95 L 134 Oz	0.89-1.22G 3.35-4.65Liter 114-157 Oz	0.01G 0.05L 1 Oz	Adjusts flow rate
E6	LT Bypass Valve flow rate:	0.92G 3.45L 118 Oz	0.77-1.07 G 2.90-4.05Liter 99-137 Oz	0.01G 0.05L 1 Oz	Adjusts flow rate
E7	RT Bypass Valve flow rate:	0.92G 3.45L 118 Oz	0.77-1.07 G 2.90-4.05Liter 99-137 Oz	00.01G 0.05L 1 Oz	Adjusts flow rate
E10	Calibration Procedure	Start NO+	Press middle button to activate procedure		Follow directions on next page

**NOTE**

- Check for these causes for the difference in the programmed value to the brewed value. These must be corrected first.
- CSD spray head is not in place. This will always result in an increased flow volume
- Flow related error codes 100, 101 - see page 11. Reduced water flow can cause reduced brew volume.
- Clogged or fouled inlet valve or improperly installed inlet valve. See page 16.
- Bypass turned on and flow is off or incorrect. Bypass flow is calculated into total flow and cause short potting if faulty
- Verify that the controls that the brew time is correct, and the display is operating as the control may be turning off.
- Lime scale. This can cause erratic and sometimes random under or over brew volumes. Brew valve can drip, be stuck open or closed, or fail due to lime scale accumulation. Always correct lime scale faults before changing flow rate.

Changing the flow rate corrects the brew volume if it is different from the programmed value.

Flow rate can be calculated manually or by the FLOW RATE Calibration procedure (E10) on the next page. The flow rate calibration procedure is an internal program to test for and enter corrections for flow rate inconsistencies. In the procedure: the equipment will dispense for 60 seconds. The flow dispensed is carefully measured and entered into the program. The software automatically corrects the flow rate based on the difference of the actual results to the stored values.

The procedure requires a calibrated 1½ gallon/6liter container. The flow must be very accurately measured. It will be easiest to manage the readings if the brewer volume units are placed into ounces or liters for units of measure. [Go to PROGRAM B6]. Units of measure in gallons require a calculation in fractional units of measure - which can be difficult.

TESTING SHOULD BE MADE WITH AN EMPTY BREW BASKET. NO FILTER PAPER. NO COFFEE OR TEA.

<p><b>Use this formula to manually compensate for minor discrepancies in actual volume versus programmed volume.</b> See "PROGRAM" E4 to E7 For valve settings and calibration. Factory set brew valve flow rates are in liter/min</p>																	
<p>Current setting is the flow from E4,E5, E6, E7 See table above for factory set default flow rates</p>	<p><b>Default Brew Valve Flow Rate—CBS-1260 Brewers</b></p> <table border="1"> <thead> <tr> <th>CBS-1260</th> <th>gallons/minute</th> <th>Range</th> </tr> </thead> <tbody> <tr> <td>Left Brew Valve FR</td> <td>1.05</td> <td>114 to 157 Oz</td> </tr> <tr> <td>Right Brew Valve FR</td> <td>1.05</td> <td>114 to 157 Oz</td> </tr> <tr> <td>Left Bypass Valve FR</td> <td>0.92</td> <td>99 to 137 Oz</td> </tr> <tr> <td>Right Bypass Valve FR</td> <td>0.92</td> <td>99 to 137 Oz</td> </tr> </tbody> </table>		CBS-1260	gallons/minute	Range	Left Brew Valve FR	1.05	114 to 157 Oz	Right Brew Valve FR	1.05	114 to 157 Oz	Left Bypass Valve FR	0.92	99 to 137 Oz	Right Bypass Valve FR	0.92	99 to 137 Oz
CBS-1260	gallons/minute	Range															
Left Brew Valve FR	1.05	114 to 157 Oz															
Right Brew Valve FR	1.05	114 to 157 Oz															
Left Bypass Valve FR	0.92	99 to 137 Oz															
Right Bypass Valve FR	0.92	99 to 137 Oz															
$\frac{\text{ACTUAL VOLUME}}{\text{PROGRAMMED VOLUME}} \times \text{CURRENT SETTING} = \text{NEW SETTING}$ <p>Use this formula to determine the correct setting</p>	<p>Set FR lower to increase volume; set higher to decrease volume.</p>																

EXAMPLE: A three gallon brew was under by one quart (0.25 gallon) Using the formula above and the default flow rate for the brew valve (1.05) the new flow rate is 0.9625 (rounded to 0.96. Enter , save and test brew to verify the new volume  $\frac{2.75}{3.00} \times 1.05 = 0.96$

## E10 Calibration Procedure - Automatic

Flow rate calibration is required when the volume dispensed differs significantly and consistently from the brewer setting. This procedure automatically dispenses the selected valve brewer for 60 seconds. Testing should be performed with an empty brew basket. No filter paper. No coffee or tea. This procedure tests the brew valve and bypass valves (right side or left side). The quantity dispensed must be very accurately measured. Next: the dispensed quantity is entered into the brewer. The brewer firmware contains algorithms that automatically adjust the valve flow rate to dispense correctly.

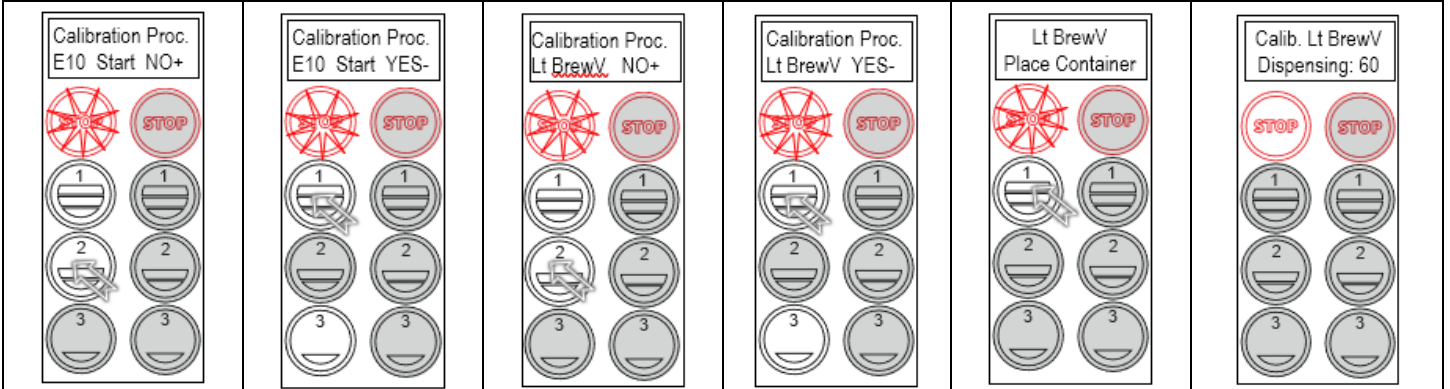

Opening screen  
Press button #2 to begin procedure

Confirm calibration  
Press button #1 to proceed.  
Proceed to next screen to choose which valve to test

Confirm which valve (button1)  
Lt BrewValve;  
Rt BrewValve  
Lt BypassValve;  
Rt BypassValve by toggling top button.  
Next: Select & press button 2 to proceed

Press button #1 to initiate left brew valve calibration  
  
Bottom button halts procedure

Place calibrated 1½ gallon/6liter container under left brew head. (Lt BrewV)  
Insert brew basket  
Press button #1 to begin testing  
\*See Note Below ↓

Brewer will dispense for one minute. Screen countdowns.  
After drip out stops ...carefully and accurately measure the dispensed quantity of hot water

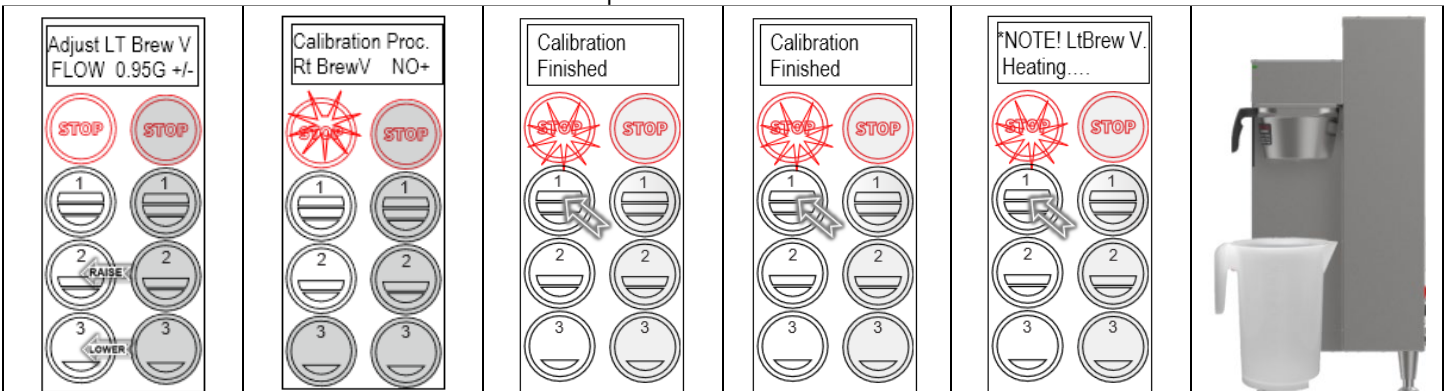

Screen shows current setting.  
  
Enter the exact quantity dispensed by toggling two lower buttons.

Software then automatically updates the flow rate for the left brew valve  
The brewer proceeds to the next valve.

Press button #1 to scroll through valves  
Rt BrewValve →  
Lt BypassValve →  
Rt BypassValve  
Last selection is → Calibration Finished

Press STOP to proceed to screen H then: Save & Exit

If hot water tank is not at correct temperature.  
Calibration holds until temperature is correct.

Brewer will continue when at temperature

Measuring Pitchers:

5 liter graduated  
Bel-Art catalog  
F28994-0000  
10 liter graduated  
Bel-Art catalog  
F28995-0000

### Default, factory set, flow rates

Left Brew Valve flow rate:	1.05	Right Brew Valve flow rate:	1.05
Left Bypass Valve flow rate:	0.92	Right Bypass Valve flow rate:	0.92

F Service Menu		Software & Code View and Settings			
POSITION	Program Items	Factory set Default	Programming Range	Increments	Notes
F1	Display Firmware	2.3.220812	Displays current version		[6/2020]
F2	Display Bootloader	2.2.220811	Displays current version		[6/2020]
F3	Select Model	CBS-1261;1262 Will need reboot	Scroll to brewer model Save & Exit	CBS-1221 CBS-1251, CBS-1252 CBS-1241, CBS-1242 CBS-1251, CBS-1252 CBS-1261, CBS-1262 MBS-1221, MBS-1251 TBS-1221, MBS-1222	<b>NOTE:</b> Overwrites all user settings (See below)
F4	Option Bypass	Yes	NO or YES		
F5	Option BB Lock	Yes	NO or YES		
F8	Backup to USB	NO	Follow prompts	Saves settings	Insert blank USB
F9	Restore From USB		Applies settings from USB		Insert USB Will need reboot
F10	Restore Defaults	NO	NO/YES		Reset to factory
F11	Error Log	Lists up to six codes, in order	1: ; 2: ;3:;4: ;5: ;6: 1=Newest/6=Oldest LAST six errors only	Newest=first Oldest=last	See Error Codes Chart for references
F12	Erase Error Log	NO +		Toggle +/- YES or NO	FACTORY USE ONLY. DO NOT RESET
F13	Service Phone #	Enter as needed			Set phone contact
F14	Override Lt BBS	NO	NO/YES	Toggle +/- YES or NO	Disables brew basket sensor
F15	Override Rt BBS	NO	NO/YES	Toggle +/- YES or NO	Disables brew basket sensor
F16	Override Lt BBL	NO	NO/YES	Toggle +/- YES or NO	Disables brew basket lock
F17	Override Rt BBL	NO	NO/YES	Toggle +/- YES or NO	Disables brew basket lock



## F Error Codes

DO NOT CLEAR ERROR CODES UNTIL ERROR IS IDENTIFIED AND CORRECTED

→Contact factory or specialized personnel for error codes

Code	Description	Possible Cause	Corrective Action
001	Software error-error on start up or corrupted software	Improper start-up or shutdown	Restart, if still fault: reload software
002	Internal flash corrupted internal data memory malfunction	Error found in cyclic redundancy check <b>CRC</b>	Restart, if still fault: reload software If not corrected: replace board
050	Short-circuit in temperature probe	Probe failure.	Replace probe.
051	Open temperature probe.	Bad probe connection, or probe failure.	Check all connections. Replace probe if necessary.
100	Initial Fill Error. Initial fill time took longer than expected after powering up.	Water supply flow rate is too low, fill valve is stuck, water line kinked or closed.	Reboot machine. If persists-investigate cause of low flow rate. (Clogged water filter, kinked line, stuck fill valve)
101	Error on refill-. Tank did not refill within expected time.	Water supply flow rate to hot water tank is too low, or fill valve stuck or damaged <b>(SEE PAGE 14)</b>	Check water supply line. Flow should be 20-75 psig, (138-517kPa) > 1gal/3.8L/min Investigate cause of low flow rate. If the flow rate is in range-replace fill valve
200	Heating flatline-Tank is boiling	Heater is on, temperature is not rising/dropping	High elevation correction. Bad heaters or temperature probe or position
201	If the hot water tank heaters are turned on during a heating cycle and tank temperature is not increasing according to software logic and the tank temperature is below setpoint	1) Failure of SSR, high limit, temperature probe, or heating element. 2) Water being removed by hot water faucet during heating (control displays "heating")	1)Test and check SSRs, high limit devices temperature probe. Check heating elements with current clamp, replace if necessary. 2)Advise staff to refrain from taking large amounts of water from hot water tank, especially during "heating".
202	Heater Shorted or Stuck SSR	Heater is off and heating SSR is stuck "ON"	Check ohms on heater (15-60Ω). SSR may be stuck in ON mode-replace SSR.
255	Keyboard [HID] error ( <u>H</u> uman <u>I</u> nterface <u>D</u> evice)	Usually from longer than 10 seconds' contact. Or faulty reassembly after service	Restart, if still fault: reload software. If mechanical: replace module
NO BSKT  <b><u>Insert Brew Basket</u></b>		Brew basket must be in place  <b>This is a SAFETY FEATURE</b>	Insert brew basket into brewer rails to enable brewer

The G Filters Counters are turned ON and OFF in B13 Water Filter ON/OFF General (B General)

**G Counters Brewer Usage, Water Filter Usage, and Statistics**

ROLE: [LT]=LIFETIME TOTALIZER Permanent total for lifetime of machine; [R]=RESETTABLE TOTALIZER operator resettable; [User]=Input needed from operator

Position	Counter	Program items	Role	Information	Increments	Notes
----------	---------	---------------	------	-------------	------------	-------

G1-G4 are for water filter maintenance. All beverage equipment must use filtered water and filter cartridges must be monitored for quality

G1	A, S, B	Filter Used	[User]	0G	Gallons/Liters	For filter life. Amount of water passed through external water filter.
G2	A, S, B	Filter Life	[User]	10,000Liters 2,625Gal	25 gal 100 L	Set the filter's expected lifespan in gal/liter. Copy the published qty. from manufacturer
G3	A, S, B	Filter Reset	[User]	NO	Toggle +/- ,Y or N	Reset when replacing external water filter
G4	A, S, B	Counter Reset	[User]	NO	Toggle +/- ,Y or N	Resets all resettable counters to zero

G5	<b>A, S, B</b>	Choose Counter		Factory set to BASIC	Basic= <b>B</b> Advanced= <b>A</b> Statistical= <b>S</b>	Stored brewer component activity.. See <b>column 2, Counters</b> , to identify where counters are located.
----	----------------	----------------	--	----------------------	--	--

NOTE: SEE CHART TOP OF PAGE 17. All three counters are always in operation and are not turned on/off by the G5 command. Position G5 allows the operator to view the Basic, Advanced and Statistical counts. Lifetime [LT] or [GxT] cannot be turned off or erased

G10-G15 Number of brews and volumes handled. Available in BASIC counter only (G5)

G10	B	Brewer Volume	[LT]	Dispensed volume	Gallons/Liters	Total of brews and hot water dispensed
G11	B	Brewer Volume	[R]			
G12	B	Lt Brews	[LT]	Left side brew total CBS-1252	Count	Total brews-Left side (CBS-1262 only)
G13	B	Lt Brews	[R]			
G14	B	Rt Brews	[LT]	Right side brew total CBS-1261&CBS-1262	Count	Total brews-Right side CBS-1261&CBS-1262
G15	B	Rt Brews	[R]			

G20-G55 component use cycles and volumes handled. Available in ADVANCED counter only (G5)

G20	A	Fill Cycles	[LT]	Hot water tank refill cycles	Count	Cycles of hot water tank refill
G21	A	Fill Cycles	[R]			
G22	A	Fill Volume	[LT]	Total volume of water for all brews	Gallons/Liters	Quantity of water for brews
G23	A	Fill Volume	[R]			
G24	A	Lt Brew Cycles	[LT]	Left brew valve operation on/off	Count	Totalized cycles of valve operation (CBS-1262 only)
G25	A	Lt Brew Cycles	[R]			
G26	A	Lt Brew Volume	[LT]	Left brew valve flow through volume	Gallons/Liters	Totalized volume through left valve (CBS-1262 only)
G27	A	Lt Brew Volume	[R]			
G28	A	Rt Brew Cycles	[LT]	Right brew valve operation on/off	Count	Totalized cycles of valve operation CBS-1261&CBS-1262
G29	A	Rt Brew Cycles	[R]			
G30	A	Rt Brew Volume	[LT]	Right brew valve flow through volume	Gallons/Liters	Totalized volume through right valve CBS-1261&CBS-1262
G31	A	Rt Brew Volume	[R]			
G32	A	Lt Bypass Cycles	[LT]	Left bypass valve operation on/off	Count	Totalized cycles of valve operation (CBS-1262 only)
G33	A	Lt Bypass Cycles	[R]			
G34	A	Lt Bypass Volume	[LT]	Left bypass valve flow through volume	Gallons/Liters	Totalized volume through left valve (CBS-1262 only)
G35	A	Lt Bypass Volume	[R]			
G36	A	Rt Bypass Cycles	[LT]	Right bypass valve flow through volume	Count	Totalized cycles of valve operation CBS-1261&CBS-1262
G37	A	Rt Bypass Cycles	[R]			
G38	A	Rt Bypass Volume	[LT]	Right bypass valve flow through volume	Gallons/Liters	Totalized volume through right valve CBS-1261&CBS-1262
G39	A	Rt Bypass Volume	[R]			
G48	A	Lt BBL Cycles	[LT]	Left brew basket lock flow through volume	Count	Totalized cycles of brew basket lock operation (CBS-1262 only)
G49	A	Lt BBL Cycles	[R]			
G50	A	Rt BBL Cycles	[LT]	Right brew basket lock operation on/off	Count	Totalized cycles of brew basket lock operation CBS-1261&CBS-1262
G51	A	Rt BBL Cycles	[R]			
G52	A	Heater Cycles	[LT]	ON/OFF switching for heating elements	Count	Totalized cycles of heater switching
G53	A	Heater Cycles	[R]			
G54	A	Heater On Time	[LT]	Total ON time for heating element	Hour	Totalized heater ON time in hours
G55	A	Heater On Time	[R]			

G80-G91 See illustration top of next page for batch button positions Available in STATISTICAL counter only (G5)

G80	S	Batch 10 Cycles	[LT]	Menu button selection and activation count	Count	Total brews-left side top button (CBS-1262 only)
G81	S	Batch 10 Cycles	[R]			
G82	S	Batch 20 Cycles	[LT]	Menu button selection and activation count	Count	Total brews-left side middle button (CBS-1262 only)
G83	S	Batch 20 Cycles	[R]			
G84	S	Batch 30 Cycles	[LT]	Menu button selection and activation count	Count	Total brews-left side bottom button (CBS-1262 only)
G85	S	Batch 30 Cycles	[R]			
G86	S	Batch 40 Cycles	[LT]	Menu button selection and activation count	Count	Total brews-right side top button CBS-1261&CBS-1262
G87	S	Batch 40 Cycles	[R]			
G88	S	Batch 50 Cycles	[LT]	Menu button selection and activation count	Count	Total brews-right side middle button CBS-1261&CBS-1262
G89	S	Batch 50 Cycles	[R]			
G90	S	Batch 60 Cycles	[LT]	Menu button selection and activation count	Count	Total brews-right side bottom button CBS-1261&CBS-1262
G91	S	Batch 60 Cycles	[R]			



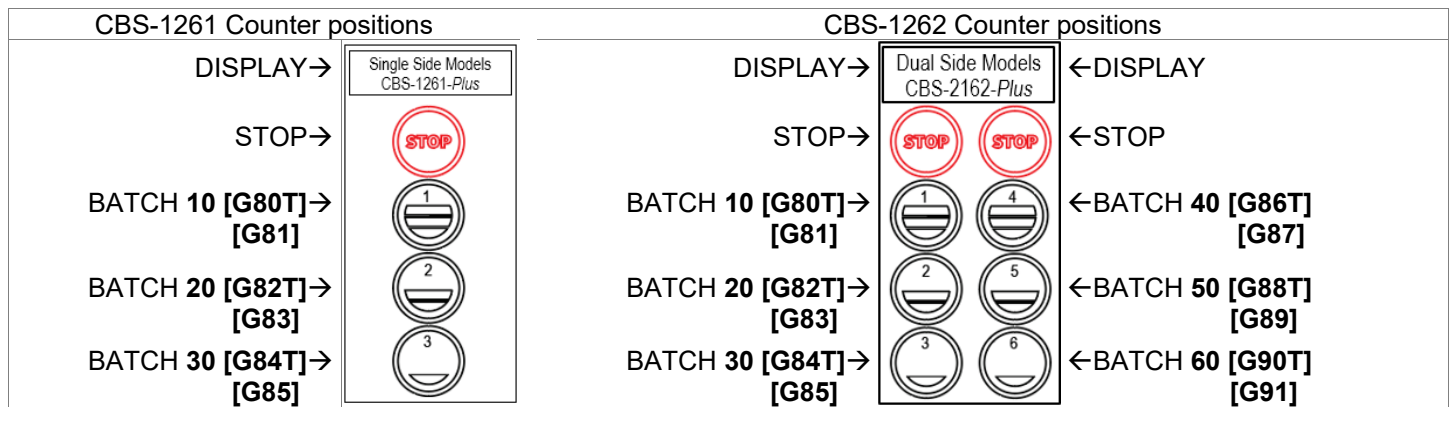

### H Save & Exit                      Saving changes and exiting PROGRAMMING

The brewer will save changes only from the “H” menu. **DO NOT** reboot brewer or toggle ON/OFF-exit as below.

#### TO EXIT PROGRAMMING & HOW TO SAVE CONTROL SETTING CHANGES

HOW TO SAVE CHANGES AND EXIT-*The brewer is in PROGRAMMING mode.*

<p>From any screen- Press STOP button until the EXIT (“H”) screen appears</p>	<p>From the “H” screen Press button <b>2</b> to toggle to the EXIT- <b>YES</b> screen</p>	<p>From EXIT screen Press button <b>1</b> to toggle to the SAVE screen</p>	<p>From SAVE screen Press button <b>2</b>, to toggle to the SAVE- <b>YES</b> screen</p>	<p>To SAVE and EXIT Press button <b>1</b> to SAVE your changes and EXIT</p>

**Note:** Only the left side buttons of a two sided brewer are used for programming

**NOTE: User Settings will be erased and overwritten to factory default settings by the following five programming changes**

1) When setting or changing units of display for the tank temperature (F Fahrenheit or C Celsius).	<b>(SETTING B4)</b>
2) When setting or changing units of display for the volume (L, G gallons).	<b>(SETTING B5)</b>
3) When setting brewer model →The software sets equipment to brewer defaults	<b>(SETTING F3)</b>
4) When loading from USB (Reprograms settings)	<b>(SETTING F9)</b>
5) When restoring defaults (Reloads to defaults )	<b>(SETTING E10)</b>

## Operator Training

Review the operating procedures with whoever will be using the brewer.

### Pay particular attention to the following areas:

1. Always pre-heat the dispensers before the first use of each day by filling them halfway with hot water and letting them stand for at least 5 minutes.
2. Do not remove the brew basket from a coffee brewer until it has stopped dripping.
3. Make sure the dispenser is empty before brewing into it.
4. Show how to attach covers, close, and or secure the dispensers for transporting.
5. Show the location and operation of the water shut off valve as well as the circuit breaker for the brewer.
6. Steam from the tank will form condensation in the vent tubes. This condensation will drip into and then out of the brew baskets. Up to 1/4 cup/118cc discharging overnight is possible. Place an appropriate container under each brew basket when not in use.
7. We recommend leaving the power to the brewer on overnight. The water tank is well insulated and very little electricity is used to keep the tank hot. Leaving the brewer in the "ON" position will also avoid delays at the beginning of shifts for the brewer to reach operating temperature.

## Cleaning & Maintenance

### After Each Brew:

1. Dispose of grounds and rinse brew basket.
2. Never strike a brew basket or hit it against a hard surface.  
This will damage the brew cone, and may damage the brew basket support rails
3. Rinse dispensers before reuse.

### Every Day:

1. Wash brew basket with hot sudsy water.
2. Pull CSD from the spray head, it is magnetically attached. Use gloves or a heavy towel. → Wash off any film and reattach. Use vinegar if limescale filming is present.
3. Clean dispensers with hot suds water and a brush, rinse and air dry.
4. Use only a soft cloth and hot suds on the outside to avoid scratches. Never use abrasives that will scratch surface.

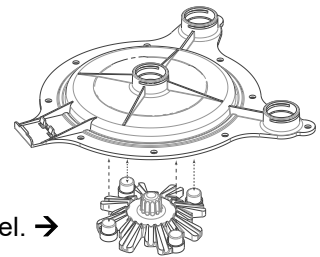

### Weekly

1. Use a commercial coffee dispenser cleaner such as URNEX™, TABZ™, DIP-IT™ or Squeak 'n Clean™.
2. Carefully Follow the instructions supplied with the cleaning product
3. Never use spray cleaners, solvent, solvent based cleaner or petroleum based polish anywhere on dispensers

### Warning

1. Turn off power before any cleaning procedure, including wiping the exterior for appearance reasons.
2. Dry the exterior, especially the face panel, before turning on power.
3. Do not apply any type of spray cleaner on the face panel of this equipment.
4. Never use solvent or solvent-based cleaner or petroleum based polish anywhere on this equipment.
5. Dry the face of the touch pad before turning on power
6. Do not electrically energize this equipment or attempt operation without all covers in place and all screws fastened.
7. Unplug machine before disassembly or servicing.

### Safety Notes

1. Professional installation is required. This appliance is manufactured only for commercial use
2. Operational requirements and maintenance for commercial cooking appliances differ from household appliances.
3. Operators must be trained for this equipment and must understand the use, maintenance and hazards.
4. Access to the service area is restricted to persons having safety/hygiene knowledge and practical experience of the coffee brewer. This appliance must be installed in locations where it can be overseen by adult trained personnel.
5. Do not attempt to move hot beverage equipment once it is filled. Drain equipment before moving.
6. FETCO commercial coffee brewers prepare large amounts of coffee or tea in a single batch using very hot water
7. Commercial coffee brewers provide very hot water from the spray head, brew basket and faucet when it is pulled.
8. Coffee brewers may continue to dispense very hot water from the mechanically operated faucet after the electronic touchpad is completely disabled by turning off the power switch on the lower back of the unit or unplugging the unit.
9. For safety, the brewer control locks the brew basket for 6.0 minutes after starting the brew.
10. Never attempt to defeat the factory set (default) time that the brew basket is locked for safety from start of brew.

**Keep these instructions for training and future reference.**

## Brewer Setup

### 1) Attach legs

NOTE-Assemble legs immediately after unpacking the brewer and before connecting it to utilities

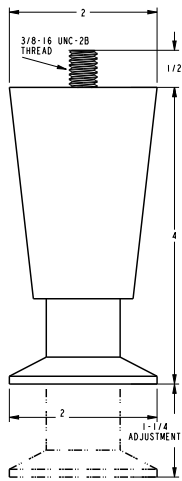

**NOTE**-Legs are located in brew basket

#### 4" legs -

Part number 1073.00007.00  
3 required for CBS-1262  
4 required for CBS-1261

Always attach legs before installing.  
Legs are sent from factory inside brew basket.

### 2) Verify dispenser locator

Reversible dispenser locator is user configurable  
From TPD-30 (3 gal) To L4D-15 or TPD-15 (1 1/2 gal)

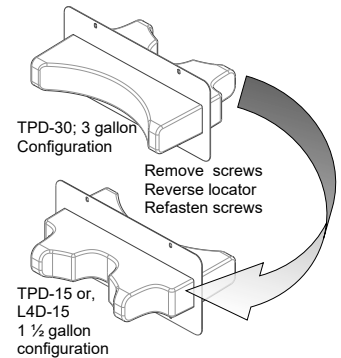
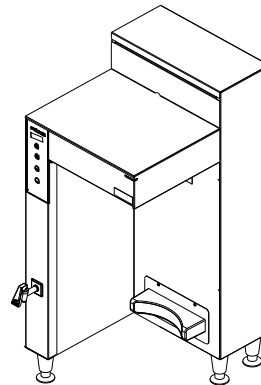

### 3) Attach water inlet adapter

Place rubber washer with screen in adapter. Hand tighten only-and 1/4 turn with wrench

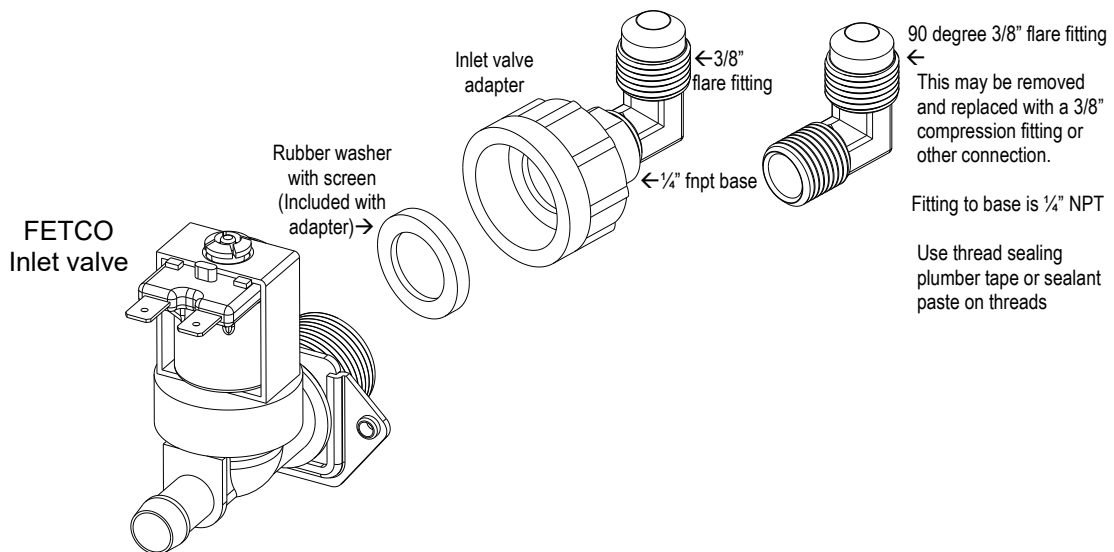

Install the adapter on inlet valve first before attaching water line. Adapter is shipped in the brew basket  
The valve threads are 3/4" BSP MALE THREAD and are not 3/4 garden hose fittings.  
Use of any other connector to valve will damage the valve  
DO NOT use USA dishwasher water adapter or USA washing machine adapter for this connection.  
The threads on these USA adapters are unusable for the valve and will damage the valve

### TO PREVENT DAMAGE AND INSURE PROPER EQUIPMENT OPERATION

The inlet valve thread is 3/4 INCH BSP (British Standard Pipe).

This valve is not a standard USA washing machine or dishwasher thread (3/4" GHT)

- Use only the plumbing adaptor kit included with this equipment. Use the gasket included in adaptor kit
- Plumber's tape is not recommended for the adapter to valve connection
- Hand tighten adapter on valve with gasket, then very lightly wrench 1/4 turn to set

-DO NOT SUBSTITUTE FITTINGS FOR CONNECTING TO WATER SUPPLY  
Damage to inlet valve from improper installation will void the warranty

NOTE: DO NOT TANK PLUMB DRAIN. DRAIN IS FOR SERVICE AND MAINTENANCE.

**General:**

1. If not installed correctly by qualified personnel, the brewer will not operate properly, and damage may result.
2. Utilize only qualified beverage equipment service technicians for service and installation.
3. Always have an empty dispenser under spray head of all coffee brewing equipment-including when at idle
4. Damages resulting from improper installation are not covered by the warranty and will void the warranty.
5. Attach the legs to the brewer before attaching the power and water lines. **See Page 15**

Below are the key points to consider before installation:

**Electrical:**

1. All CBS Series brewers require **an electrical ground wire**. Installation without grounding is dangerous.
2. Note Equipotentiality Terminal, if present, (To identify the terminals which, when connected together, bring the various parts of equipment or of a system to the same potential, not necessarily being the earth (ground) potential, e.g. for local bonding.)
3. Verify voltages, polarity, circuits, and circuit breaker access before attaching equipment.
4. Brewers in this series wire differently in regard to a neutral wire. Review the wire diagrams.
5. The electrical diagram is located in the User's Guide and online at [www.fetco.com](http://www.fetco.com).
6. Make sure of the tight grounding of the equipment and use the external ground bolt.
7. The installation must comply with applicable federal, state, and local codes having jurisdiction at your location. Check with your local inspectors to determine what codes will apply.

→See wiring diagrams on pages 28-35 for connections



**Plumbing:**

1. North America: All installations must comply with applicable federal, state, or local plumbing codes.
2. All Others: The water and waste piping and connections shall comply with the International Plumbing Code, International Code Council (ICC), or to the Uniform Plumbing Code (IAPMO).
3. Install a backflow prevention device. Most municipalities require a recognized backflow preventer  
Usable on all hot beverage and cold beverage equipment is a WATTS® SD-2 or SD-3.  
WATTS spring loaded double check valve models are accepted by most zoning authorities.  
→The check valve should be as close to the water supply inlet of the beverage equipment as possible
4. All beverage equipment must use a water filter. A finishing carbon filter is preferred
5. Install the filter unit after a water shutoff valve and in a position to facilitate filter replacement.
6. The water line and newly installed filter cartridge must be flushed thoroughly prior to connecting it to the brewer to prevent debris from contaminating the machine
7. Verify that the water line will provide a flow rate of at least 1½ gpm/(5.7lpm) per minute and the water pressure is between 20-75 psig (138-517kPa) before making any connections
8. Only use the supplied factory fitting to attach water supply line to brewer (shipped in brew basket) **See page 15**
9. The supplied fitting is a 3/8" flare/compression fitting for 1/4" supply line. Other adaptors may be substituted.
10. Hand tighten the factory fitting when connecting the stub on the brewer. This will reduce stress on the internal connections and reduce the possibility of leaks developing after the install has been completed

**Tank Drain**

The water tank must be drained before maintenance procedures, and when the unit is to be relocated or shipped. Drain is for service use only and must not be permanently connected. NOTE: Never plumb a water line to the drain.

1. Disconnect power and water to unit. DANGER: Ensure that all utility connections to the brewer are broken.
2. Move the unit near a sink or obtain a container large enough to hold four gallons of water.  
→Note: The CBS-1261 hot water tank when full holds 8.6 gallons; the CBS-1262 15.9 gallons.
3. Remove the front panel and tank cover and allow the tank to cool to a safe temperature
4. The tank drain line and clamp are located inside-under the hot water tank. Pinch the drain line clamp to close
5. Locate the fill valve against the back wall, using pliers, loosen the hose clamp and move it back over the tube.  
→Note Do not loosen the hose clamp to the bottom of the hot water tank
6. Crimp the tube an inch or two away from the drain plug to prevent water from flowing and pull it off the valve.
7. Pull the tube end out of the brewer and position over sink or bucket.
8. Release the crimped tube and hose clamp and allow the water to flow into the sink or container.
9. Reverse steps 4-8 when service is complete. Ensure pinch clamp is open and hose clamps are in place.

Brewer	Hot Water Tank Capacity	OPEN Leave open for use	
CBS-1261 Single	8.6 gal 33 liter		
CBS-1262 Twin	15.9 gal 60 liter	PINCH SHUT To drain tank & service brewer	



## Installation safety and hygiene directions-For International and CE equipment

1. Access to the service area is restricted to persons having safety/hygiene knowledge and practical experience of the coffee brewer. This appliance must be installed in locations where it can be overseen by trained personnel.
2. For proper operation, this appliance must be installed indoors where the temperature is between 10°C/50°F to 35°C/95°F. Drain and remove all liquid from equipment and lines if exposed to freezing temperatures.
3. All commercial cooking equipment, including this unit, is not intended for use by children or persons with reduced physical, sensory, or mental capabilities. Ensure proper supervision of children and keep them away from the unit.
4. Children should be supervised to ensure that they do not play around hot beverage equipment.
5. This unit must be installed and serviced by qualified personnel only.
6. Installation must conform to all local electrical and plumbing codes. Installation by unqualified personnel will void the unit warranty and may lead to electric shock or burn, as well as damage to unit and/or its surroundings.
7. If the power cord requires repair or replacement-it must be performed by the manufacturer or authorized service personnel with the specified cord only from the manufacturer in order to avoid a hazard.
8. Review the dimensions for the unit and verify that it will fit properly in the space intended for it. Verify that the counter or table will support the total weight of the brewer and dispensers when filled (See: Technical Data).
9. Place the brewer on the counter or stand. When the brewer is in position, level it front to back as well as side-to-side by adjusting the legs.
10. Brewers will need a sturdy supported surface for operation. Do not move brewers when filled.
11. Do not tilt appliance more than 10° to insure safe operation.
12. Unit is for protected indoor use only. Do not steam clean or use excessive water on unit.
13. This unit is not “jet-proof” construction. Do not pressure wash or use jet spray to clean this unit.
14. The unit is not waterproof-do not submerge or saturate with water.

**Equipment exposed to flood and contaminated must not be used due to electrical and food safety.  
Do not operate if unit has been submerged or saturated with water.**

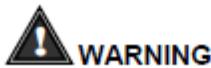

### WARNING

All electrical connections must be in accordance with local electrical codes and any other applicable codes. If the supply cord is damaged, it must be replaced by the manufacturer, its service agent, or similarly qualified persons in order to avoid a hazard.

To prevent an electric shock hazard this device must be bonded to equipment in close proximity with an equipotential bonding conductor. This device is equipped with a bonding lug for this purpose and is marked with the following symbol



	<b>WARNING</b>	To reduce risk of electric shock or fire.
		FETCO® Hot Beverage Equipment is for commercial use only.
		Do not remove or open cover. No user serviceable parts inside. Refer installation and service to qualified personnel.
		Caution, disconnect from power supply before servicing.
		GROUND: National Electrical Code requires separate grounding wire.
		Use dedicated circuit with capacity rated by local code or National Electrical Code for the current draw of this equipment. Check serial number plate on right side for power requirements.
		Locate unit away from source of heat. Do not install or use near combustibles.
		<b>THIS APPLIANCE IS ENERGIZED WHENEVER IT IS CONNECTED TO A POWER SOURCE</b>
		<b>FAILURE TO COMPLY RISKS EQUIPMENT DAMAGE, PROPERTY DAMAGE, FIRE, OR SHOCK HAZARD</b>
<b>Notice</b>		This equipment must be installed with a backflow protection device to comply with federal, state or local municipality codes.
<b>Notice</b>		Read the user guide before installing and operating this unit.

Labels and warnings for hot beverage equipment

For BACK PANEL of equipment (1046.00035.00)

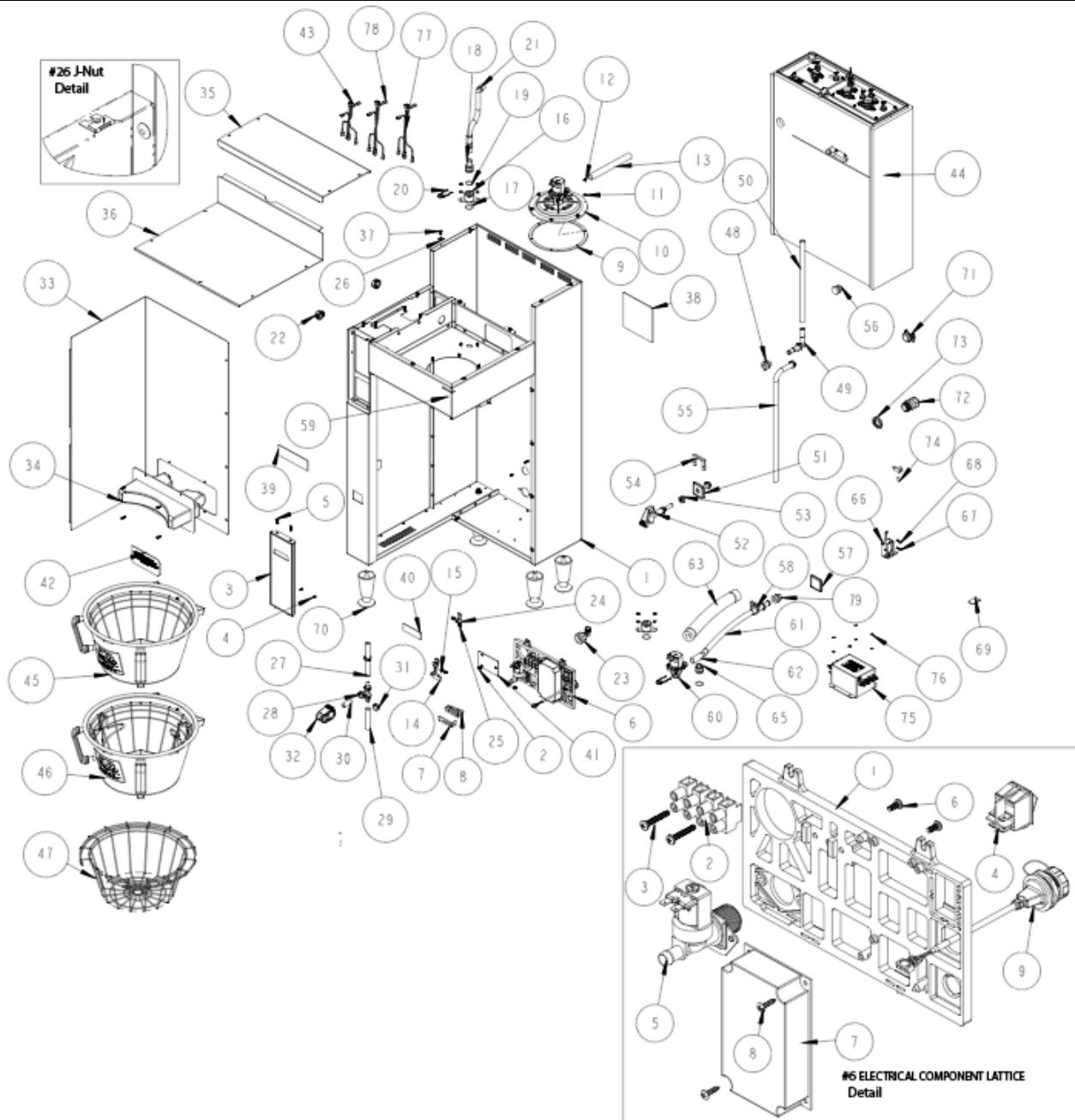

Drawing 1101.00576.00 CBS-1261-Parts Page 1/2

#	QTY	PART NO	DESCRIPTION
1	1	1111.00108.00	WELDMENT BODY, CBS-2261
2	7	1084.00051.00	NUT, HEX LOCKWASHER, #8-32, 18-8 ST. STL.
3	1	1102.00480.00	FRONT PANEL ASSY, SINGLE, PLUS SERIES
4	2	1082.00029.00	SCREW, #6 X 3/8 LG, TRUSS HD PHIL, SHEET MTL
5	2	1082.00058.00	SCREW, # 8-32 X 5/8, FLAT HD, PH, 18-8 SS
6	1	1102.00471.00	ELECTRICAL COMPONENT LATTICE, NEXT GEN XV+ [Purchase repair parts 6-1 to 6-8, below]
6-1	1	1023.00350.00	ELECTRICAL MOUNTING LATTICE, COMMON
6-2	1	1052.00023.00	EUROSTRIP HE16 TERM. BLOCK, 4 POLE, 63 AMP, 18-8 AWG
6-3	2	1082.00139.00	#8-16x1" CROSS RECESS PAN HEAD PLASTIC THREAD SCREW
6-4	1	1058.00024.00	SWITCH, POWER, DOUBLE POLE, 16A, 125/250 VAC
6-5	1	1057.00043.00	SOLENOID VALVE, 5.5L/min, 180 DEG, 24VDC
6-6	2	1082.00010.00	SCREW, PAN HD. PHIL. MACH., M4x10 ZINC-PLATED
6-7	1	1052.00059.00	POWER SUPPLY, 90-264VAC/24VDC, 2.25A
6-8	2	1082.00020.00	SCREW, #6 X 5/8, TRUSS HD PHIL, SHEET MTL
7	1	1097.00171.00	ADHESIVE, RGB LED BAR
8	1	1023.00390.00	LENS, LIGHT BAR, BLACK
9	1	1024.00113.00	LARGE SPRAY HEAD GASKET
10	1	1102.00482.00	QUICK CONNECT SPRAYHEAD ASSEMBLY, LARGE, RETROFIT (SEE PAGE 27)
11	10	1083.00010.00	WASHER, #12 SCREW W/NEOPRENE-BONDED

Parts list continued on next page

#	QTY	PART NO	DESCRIPTION	Continued from previous page	Drawing	1101.00576.00	CBS-1261-Parts	Page 1/2
12	10	1084.00006.00	NUT, 8-32 18-8 HEX MACHINE SCREW					
13	1	1025.00144.00	TUBE, SILICONE, 3/4" OD X 1/2" ID X 6.625" LG, BREW					
14	1	1102.00113.00	SWITCH, REED, ASSEMBLY					
15	2	1029.00006.00	NUT, FINGER KNURLED, #4-40					
16	2	1023.00396.00	BASE, QUICK CONNECT BYPASS/VENT, RETROFIT					
17	2	1024.00002.00	O RING, 15/16 X 1/16 CS, DASH #019					
18	1	1023.00343.00	VENT INSERT, QUICK CONNECT					
19	2	1024.00106.00	O-RING, 13/16"OD X 11/16"ID X 1/16" TH, FOR QUICK CONNECT					
20	2	1023.00342.00	QUICK CONNECT CLIP					
21	1	1024.00098.00	VENT TUBE, CBS- EXTRACTOR SERIES					
22	2	1086.00004.00	BUSHING, SNAP, 1" MOUNTING HOLE					
23	1	1102.00243.00	ADAPTER ASSY, 3/4" BSP x 1/4" NPT x 3/8" TUBE					
24	2	1065.00009.00	GROUND LUG CONNECTOR, 14-2 AWG, ALUMINUM					
25	1	1044.00012.00	LABEL GROUND, CE					
26	14	1084.00011.00	NUT, CLIP ON (J-NUT), #6-32, 22-20 GA., BLK-PH FINISH					
27	1	1025.00100.00	TUBE, 9/16"OD X 5/16"ID X 9"LG					
28	1	1029.00002.00	FITTING, HOSE BARB TEE, SIZE 3/8"					
29	1	1025.00077.00	TUBE, 9/16"OD X 5/16"ID X 6.50" LG.					
30	1	1025.00058.00	TUBE, 9/16"OD X 5/16"ID X 25.00"LG					
31	7	1086.00003.00	UNICLAMP, 15.9 HOSE OD CLAMP					
32	1	1086.00009.00	CLAMP, 3/4" MAX TUBE OD FLOW CONTROL					
33	1	1112.00546.00	WELDMENT FRONT COVER, CBS-2260					
34	1	1102.00487.00	ASSEMBLY LOCATOR L4D-15, TPD-30, CBS 12/2260, BLACK					
35	1	1001.00439.00	COVER TOP, CBS-2261					
36	1	1001.00440.00	COVER, UPPER BASE, CBS-2261					
37	18	1082.00017.00	SCREW, TRUSS HD. PHIL. MACHINE, # 6-32 X 1/2 LG.					
38	1	1046.00035.00	LABEL, WARNING "TO REDUCE RISK OF ELECTRIC SHOCK OR FIRE"					
39	1	1046.00003.00	LABEL, CSD WARNING, 1.5" X 5.0"					
40	1	1041.00033.00	BLACK EXTRACTOR PLUS LABEL, LASER ENGRAVED					
41	1	1044.00006.00	CARD, SINGLE OR THREE PHASE JUMPER INSTRUCTION					
42	1	1046.00020.00	TAG, INFORMATION					
43	1	1402.00115.10	WIRE HARNESS, CBS-1260-PLUS, LOW AMP, UNIVERSAL					
44	1	1104.00199.00	TANKASSEMBLY,CBS-2261,3X3KW/240VAC					
44	1	1104.00200.00	TANKASSEMBLY,CBS-2261,3X4KW/240VAC					
44	1	1104.00201.00	TANKASSEMBLY,CBS-2261,3X5KW/240VAC					
45	1	B00828004	BREW BASKET ASSY, CBS-2060/2160'S INCLUDED WITH BREWER					
46		B00828005	BREW BASKET ASSY, CBS-2060/2160'S, W/ CLIPS OPTIONAL-Customer purchase					
47		1009.00009.00	1/2 BATCH BREW BASKET, INSERT ONLY, OPTIONAL-Customer purchase					
48	1	1024.00111.00	GROMMET, SILICONE, W/ POSITION TABS					
49	1	1023.00362.00	FITTING VENT, ELBOW, .375" X .375", SELF POSITIONING					
50	1	1013.00131.00	TUBE, 304SS, .625OD X .065 WALL X 11-1/2" LG.					
51	1	1023.00348.00	HOT WATER INSERT, MANUAL FAUCET					
52	1	1071.00055.00	FAUCET, HOT WATER, PSC-BR-8, WITH FLAT AND STEM					
53	1	1084.00048.00	JAM NUT, 1/2-20 UNF, NICKEL PLATED BRASS					
54	1	1003.00370.00	HOT WATER INSERT LOCK					
55	1	1025.00068.00	TUBE, 9/16"OD X 5/16"ID X 21.75"LG					
56	1	1024.00051.00	GROMMET, SILICONE, BLANK					
57	1	1023.00349.00	HOT WATER INSERT, NO FAUCET					
58	1	1023.00203.00	FITTING, STRAIGHT, GROMMET, .625"					
59	1	1023.00345.00	ORIFICE INSERT, QUICK CONNECT, 5/16" HOLE					
60	1	1057.00076.00	VALVE ASSEMBLY, COMPLETE, NG, DELTROL (SEE PAGE 27)					
61	1	1025.00098.00	TUBE, 5/8"OD X 3/8"ID X 11.25"LG					
62	1	1025.00138.00	TUBE, SILICONE, 3/4" OD X 1/2" ID X 1-1/2" LG, HOT WATER					
63	1	1022.00087.00	INSULATION, 5/8" ID X 3/8" TH, 11"LG					
64	1	1086.00018.00	CLAMP, HOSE, .875-1.00 DIA. RANGE					
65	1	1023.00344.00	PLUG INSERT, QUICK CONNECT					
66	1	1102.00219.00	ASSEMBLY, BB LOCKER, 24VDC					
67	6	1083.00009.00	WASHER, #6 SCREW , INTL TOOTH LOCKWASHER					
68	2	1084.00010.00	NUT, HEX, #6-32, UNDERSIZED, ZINC PLATED					
69	1	1003.00259.00	BRACKET, BREW BASKET LOCK COVER					
70	4	1073.00007.00	LEG, FLANGE FOOT, 4" HIGH					
71	1	1086.00008.00	CONNECTOR, CLAMP, NON-METALLIC CABLE, 3/4"					
72	1	1086.00031.00	SKINTOP, 3/4" NPT, 0.354" - 0.630" DIA CABLE, BLK					
73	1	1086.00032.00	LOCKNUT, SKINTOP, 3/4" NPT, BLACK HEX					
74	1	1044.00013.00	LABEL EQUIPOTENTIALITY, CE					
75	1	1052.00050.00	EMI FILTER, 25A, 250/440VAC, 50/60Hz					
76	4	1084.00012.00	NUT, HEX, #6-32 MACHINE SCREW					
77	1	1402.00112.10	WIRE HARNESS, CBS-1252/61, HIGH AMP, 1 OR 3PH, 3 HEATERS, UL					
78	1	1402.00120.10	WIRE HARNESS, CBS-1252/61, 3 HEATER, HIGH AMP, 3L-N-PE, 220/380-240/415, INTL/CE					
79	1	1024.00050.00	GROMMET, SILICONE, 11.4mm ID					



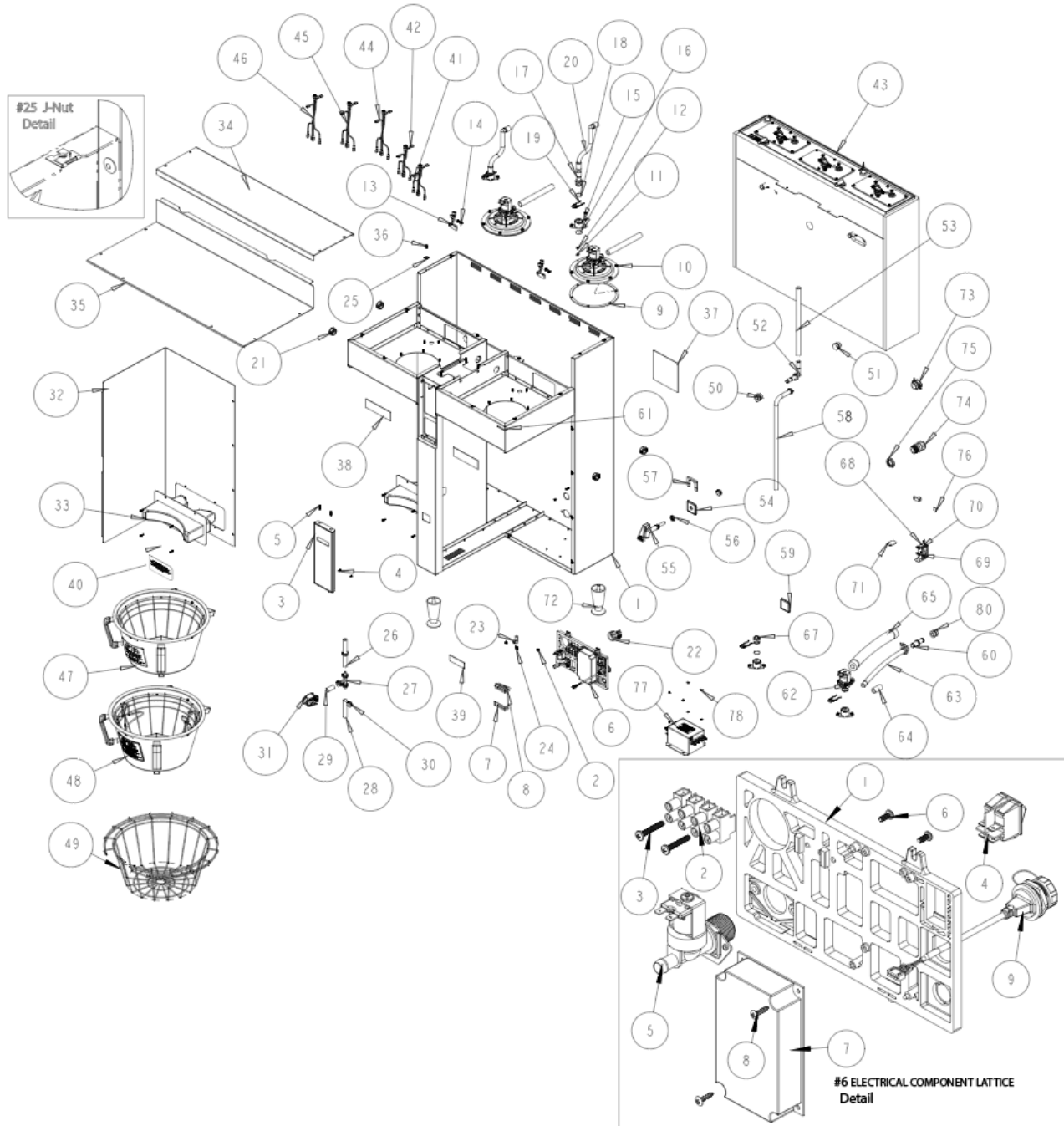

Drawing 1101.00578.00 CBS-1262-Parts Page 1/2

#	QTY	PART NO	DESCRIPTION
1	1	1111.00109.00	WELDMENT BODY, CBS-2262
2	7	1084.00051.00	NUT, HEX LOCKWASHER, #8-32, 18-8 ST. STL.
3	1	1102.00470.00	FRONT PANEL ASSY, DOUBLE, PLUS SERIES
4	2	1082.00029.00	SCREW, #6 X 3/8 LG, TRUSS HD PHIL, SHEET MTL
5	2	1082.00058.00	SCREW, # 8-32 X 5/8, FLAT HD, PH, 18-8 SS
6	1	1102.00471.00	ELECTRICAL COMPONENT LATTICE, NEXT GEN XV+ [Purchase repair parts 6-1 to 6-8, below]
6-1	1	1023.00350.00	ELECTRICAL MOUNTING LATTICE, COMMON
6-2	1	1052.00023.00	EUROSTRIP HE16 TERM. BLOCK, 4 POLE, 63 AMP, 18-8 AWG
6-3	2	1082.00139.00	#8-16x1" CROSS RECESS PAN HEAD PLASTIC THREAD SCREW
6-4	1	1058.00024.00	SWITCH, POWER, DOUBLE POLE, 16A, 125/250 VAC
6-5	1	1057.00043.00	SOLENOID VALVE, 5.5L/min, 180 DEG, 24VDC
6-6	2	1082.00010.00	SCREW, PAN HD. PHIL. MACH., M4x10 ZINC-PLATED
6-7	1	1052.00059.00	POWER SUPPLY, 90-264VAC/24VDC, 2.25A
6-8	2	1082.00020.00	SCREW, #6 X 5/8, TRUSS HD PHIL, SHEET MTL
7	1	1097.00171.00	ADHESIVE, RGB LED BAR
8	1	1023.00390.00	LENS, LIGHT BAR, BLACK
9	2	1024.00113.00	LARGE SPRAYHEAD GASKET
10	2	1102.00482.00	QUICK CONNECT SRAVHEAD ASSEMBLY, LARGE, RETROFIT (SEE PAGE 27)
11	20	1083.00010.00	WASHER, #12 SCREW W/NEOPRENE-BONDED
12	20	1084.00006.00	NUT, 8-32 18-8 HEX MACHINE SCREW
13	2	1102.00113.00	SWITCH, REED, ASSEMBLY
			Parts list continued on next page

#	QTY	PART NO	DESCRIPTION
14	4	1029.00006.00	NUT, FINGER KNURLED, #4-40
15	4	1023.00396.00	BASE, QUICK CONNECT BYPASS/VENT, RETROFIT
16	4	1024.00002.00	O RING, 15/16 X 1/16 CS, DASH #019
17	2	1023.00343.00	VENT INSERT, QUICK CONNECT
18	3	1024.00106.00	O-RING, 13/16"OD X 11/16"ID X 1/16" TH, FOR QUICK CONNECT
19	4	1023.00342.00	QUICK CONNECT CLIP
20	2	1024.00098.00	VENT TUBE, CBS- EXTRACTOR SERIES
21	4	1086.00004.00	BUSHING, SNAP, 1" MOUNTING HOLE
22	1	1102.00243.00	ADAPTER ASSY, 3/4" BSP x 1/4" NPT x 3/8" TUBE
23	2	1065.00009.00	GROUND LUG CONNECTOR, 14-2 AWG, ALUMINUM
24	1	1044.00012.00	LABEL GROUND, CE
25	15	1084.00011.00	NUT, CLIP ON (J-NUT), #6-32, 22-20 GA., BLK-PH FINISH
26	1	1025.00100.00	TUBE, 9/16"OD X 5/16"ID X 9"LG
27	1	1029.00002.00	FITTING, HOSE BARB TEE, SIZE 3/8"
28	1	1025.00077.00	TUBE, 9/16"OD X 5/16"ID X 6.50" LG.
29	1	1025.00058.00	TUBE, 9/16"OD X 5/16"ID X 25.00"LG
30	7	1086.00003.00	UNICLAMP, 15.9 HOSE OD CLAMP
31	1	1086.00009.00	CLAMP, 3/4" MAX TUBE OD FLOW CONTROL
32	1	1112.00546.00	WELDMENT FRONT COVER, CBS-2260
33	2	1102.00487.00	ASSEMBLY LOCATOR L4D-15, TPD-30, CBS 12/2260, BLACK
34	1	1001.00445.00	COVER TOP, CBS-2262
35	1	1001.00446.00	COVER, UPPER BASE, CBS-2262
36	23	1082.00017.00	SCREW, TRUSS HD. PHIL. MACHINE, # 6-32 X 1/2 LG.
37	1	1046.00035.00	LABEL, WARNING "TO REDUCE RISK OF ELECTRIC SHOCK OR FIRE"
38	2	1046.00003.00	LABEL, CSD WARNING, 1.5" X 5.0"
39	1	1041.00033.00	BLACK EXTRACTOR PLUS LABEL, LASER ENGRAVED
40	1	1046.00020.00	TAG, INFORMATION
41	1	1402.00115.10	WIRE HARNESS, CBS-1260-PLUS, LOW AMP, UNIVERSAL
42	1	1402.00115.11	WIRE HARNESS ADDITION, CBS-1262-PLUS, LOW AMP
43	1	1104.00192.00	TANK ASSEMBLY, CBS-2262, 3 X 3KW/240VAC
43	1	1104.00193.00	TANK ASSEMBLY, CBS-2262, 6 X 3KW/240VAC
43	1	1104.00194.00	TANK ASSEMBLY, CBS-2262, 3 X 4KW/240VAC
43	1	1104.00195.00	TANK ASSEMBLY, CBS-2262, 6 X 4KW/240VAC
43	1	1104.00196.00	TANK ASSEMBLY, CBS-2262, 3 X 5KW/240VAC
44	1	1402.00116.10	WIRE HARNESS, CBS-1262, HIGH AMP, 3 HEATERS, UL
45	1	1402.00116.11	WIRE HARNESS ADDITION, CBS-1262, HIGH AMP, 6(3) HEATERS, UL(CE)
46	1	1402.00116.12	WIRE HARNESS ADDITION, CBS-1262, HIGH AMP, 3 HEATERS, CE
47	2	B00828004	BREW BASKET ASSY, CBS-2060/2160'S
48		B00828005	BREW BASKET ASSY, CBS-2060/2160'S, W/ CLIPS OPTIONAL-Customer purchase
49		1009.00009.00	1/2 BATCH BREW BASKET, INSERT ONLY, OPTIONAL-Customer purchase
50	1	1024.00111.00	GROMMET, SILICONE, W/ POSITION TABS
51	2	1024.00051.00	GROMMET, SILICONE, BLANK
52	1	1023.00362.00	FITTING VENT, ELBOW, .375" X .375", SELF POSITIONING
53	1	1013.00131.00	TUBE, 304SS, .625OD X .065 WALL X 11-1/2" LG.
54	1	1023.00348.00	HOT WATER INSERT, MANUAL FAUCET
55	1	1071.00055.00	FAUCET, HOT WATER, PSC-BR-8, WITH FLAT AND STEM
56	1	1084.00048.00	JAM NUT, 1/2-20 UNF, NICKEL PLATED BRASS
57	1	1003.00370.00	HOT WATER INSERT LOCK
58	1	1025.00068.00	TUBE, 9/16"OD X 5/16"ID X 21.75"LG
59	1	1023.00349.00	HOT WATER INSERT, NO FAUCET
60	1	1023.00203.00	FITTING, STRAIGHT, GROMMET, .625"
61	1	1023.00345.00	ORIFICE INSERT, QUICK CONNECT, 5/16" HOLE
62	1	1057.00076.00	VALVE ASSEMBLY, COMPLETE, NG, DELTROL (SEE PAGE 27)
63	1	1025.00098.00	TUBE, 5/8"OD X 3/8"ID X 11.25"LG
64	1	1025.00138.00	TUBE, SILICONE, 3/4" OD X 1/2" ID X 1-1/2" LG, HOT WATER
65	1	1022.00087.00	INSULATION, 5/8" ID X 3/8" TH, 11"LG
66	1	1086.00018.00	CLAMP, HOSE, .875-1.00 DIA. RANGE
67	1	1023.00344.00	PLUG INSERT, QUICK CONNECT
68	1	1102.00219.00	ASSEMBLY, BB LOCKER, 24VDC
69	6	1083.00009.00	WASHER, #6 SCREW, INTL TOOTH LOCKWASHER
70	2	1084.00010.00	NUT, HEX, #6-32, UNDERSIZED, ZINC PLATED
71	1	1003.00259.00	BRACKET, BREW BASKET LOCK COVER
72	3	1073.00007.00	LEG, FLANGE FOOT, 4" HIGH
73	1	1086.00008.00	CONNECTOR, CLAMP, NON-METALLIC CABLE, 3/4"
74	1	1086.00031.00	SKINTOP, 3/4" NPT, 0.354" - 0.630" DIA CABLE, BLK
75	1	1086.00032.00	LOCKNUT, SKINTOP, 3/4" NPT, BLACK HEX
76	1	1044.00013.00	LABEL EQUIPOTENTIALITY, CE
77	1	1052.00050.00	EMI FILTER, 25A, 250/440VAC, 50/60Hz
78	4	1084.00012.00	NUT, HEX, #6-32 MACHINE SCREW
79	2	1025.00144.00	TUBE, SILICONE, 3/4" OD X 1/2" ID X 6.625" LG, BREW
80	1	1024.00050.00	GROMMET, SILICONE, 11.4mm ID



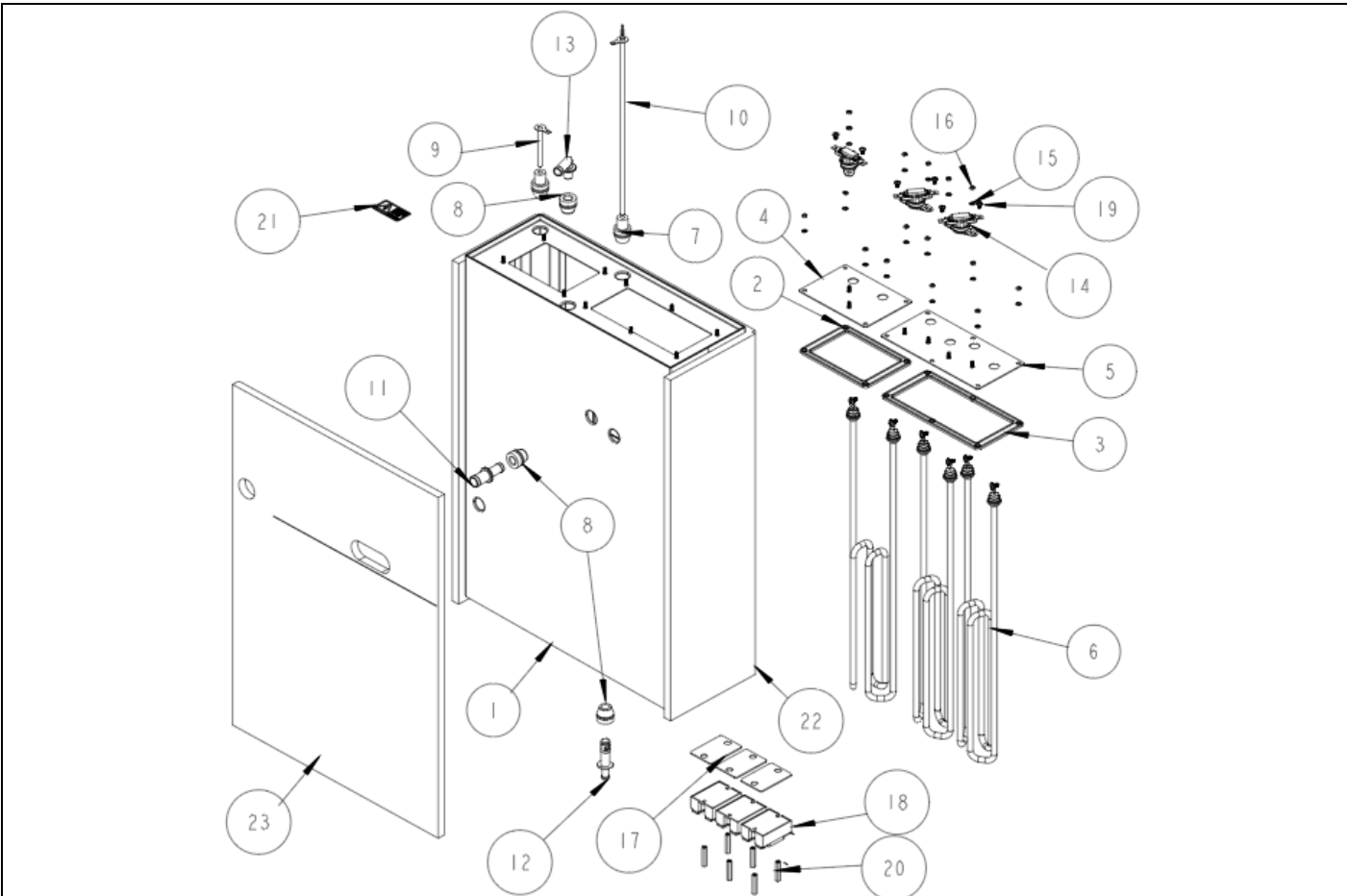

CBS-1261 Hot Water Tank three heater drawings 1104.00199.00, 1104.00200.00, 1104.00201.00

#	QTY	PART NO	DESCRIPTION
1	1	1114.00174.00	WELDMENT TANK, CBS-2261. LASER
2	1	1024.00115.00	TANK GASKET - NG HEATER PLATE, ONE ELEMENT
3	1	1024.00114.00	TANK GASKET - NG HEATER PLATE, TWO ELEMENT
4	1	1114.00181.00	WELDMENT TANK HEATER BRACKET, NG-2232
5	1	1114.00176.00	WELDMENT TANK HEATER BRACKET, NG-2231
6	3	1107.00005.00	HEATER ASSEMBLY, IMMERSION 3kW/240VAC
6	3	1107.00010.00	HEATER ASSEMBLY, IMMERSION 4kW/240VAC
6	3	1107.00032.00	HEATER ASSEMBLY, IMMERSION 5kW/240VAC
7	2	1024.00053.00	LEVEL AND TEMP PROBE GROMMET
8	3	1024.00050.00	GROMMET, SILICONE, 11.4mm ID
9	1	1112.00019.00	PROBE WELDMENT, WATER LEVEL 2.600" LG
10	1	1102.00234.00	PROBE ASSEMBLY, TEMP. AND LLC 12" LONG
11	1	1023.00203.00	FITTING, STRAIGHT, GROMMET, .625"
12	1	1023.00166.00	FITTING, COLD WATER INLET, GROMMET DESIGN
13	1	1023.00212.00	FITTING, ELBOW, GROMMET, .500"
14	3	1053.00052.00	THERMOSTAT, SINGLE SHOT, SCREW CONNECTIONS, 240V/25A,
15	16	1083.00009.00	WASHER, #6 SCREW , INTL TOOTH LOCKWASHER
16	16	1084.00010.00	NUT, HEX, #6-32, UNDERSIZED, ZINC PLATED
17	3	1003.00140.00	ALUMINUM BRACKET FOR SSR
18	3	1052.00033.00	RELAY, SOLID STATE, 50A/480VAC, W/BUILD IN VARISTOR
19	6	1082.00136.00	BRASS SCREW, #8-32 X 1/4", PHILLIPS PAN HEAD
20	6	1081.00042.00	STANDOFF, 1/4" HEX
21	1	1044.00004.00	LABEL, DANGER, HIGH VOLTAGE
22	1	1022.00040.00	INSULATION, TANK, BACK, CBS-2061E
23	1	1022.00090.00	INSULATION TANK FRONT, CBS-2161 XTS



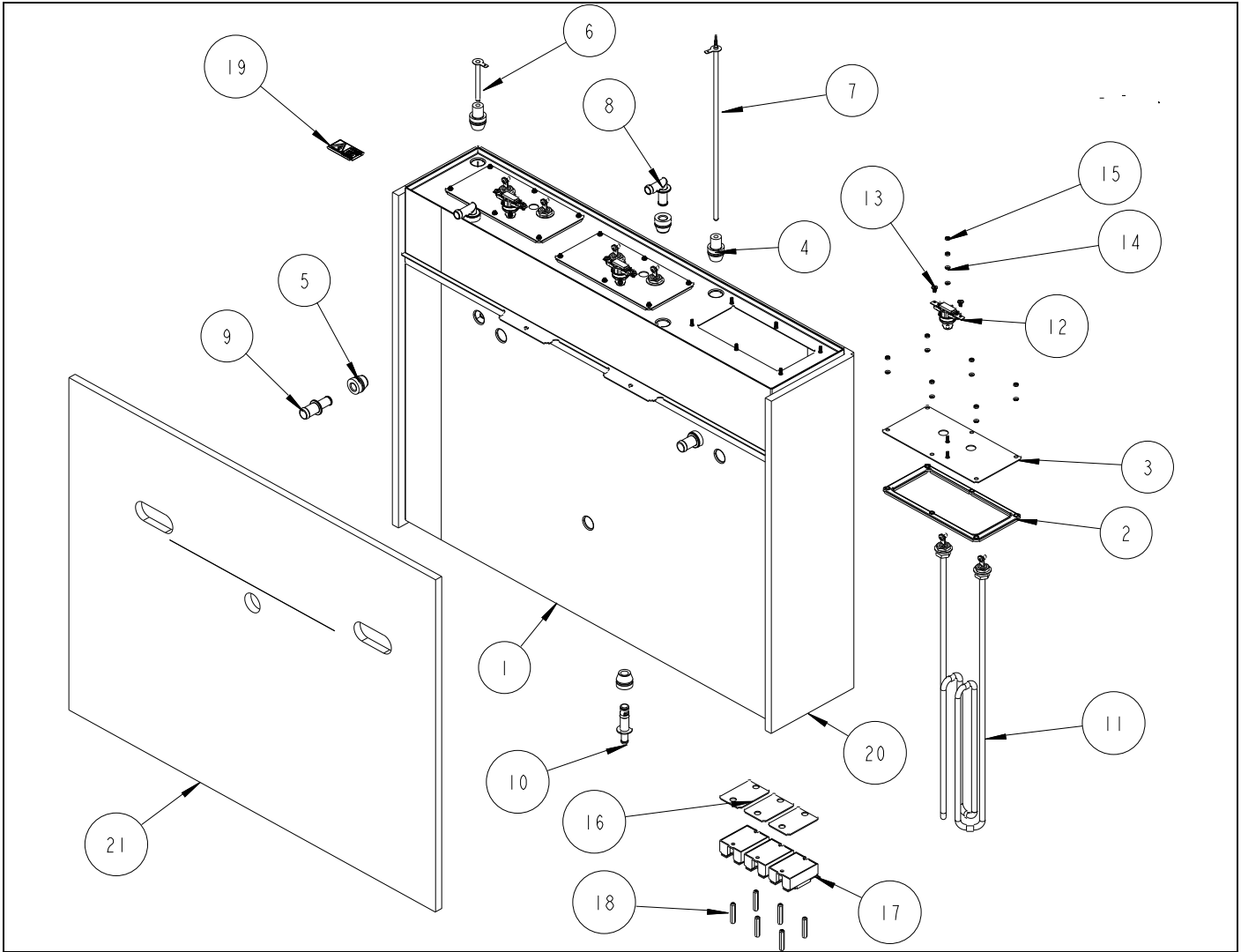

CBS-1262 Hot Water Tank three heater drawings 1104.00192.00, 1104.00194.00, 1104.00196.00

#	QTY	PART NO	DESCRIPTION
1	1	1114.00175.00	WELDMENT, TANK, CBS-12/2262
2	3	1024.00114.00	TANK GASKET - NG HEATER PLATE, TWO ELEMENT
3	3	1114.00184.00	WELDMENT TANK HEATER BRACKET, NG-LARGE, TWO HEATER
4	2	1024.00053.00	LEVEL AND TEMP PROBE GROMMET
5	5	1024.00050.00	GROMMET, SILICONE, 11.4mm ID
6	1	1112.00019.00	PROBE WELDMENT, WATER LEVEL 2.600" LG
7	1	1102.00234.00	PROBE ASSEMBLY, TEMP. AND LLC 12" LONG
8	2	1023.00212.00	FITTING, ELBOW, GROMMET, .500"
9	2	1023.00203.00	FITTING, STRAIGHT, GROMMET, .625"
10	1	1023.00166.00	FITTING, COLD WATER INLET, GROMMET DESIGN
11	3	1107.00005.00	HEATER ASSEMBLY, IMMERSION 3kW/240VAC
11	3	1107.00010.00	HEATER ASSEMBLY, IMMERSION 4kW/240VAC
11	3	1107.00032.00	HEATER ASSEMBLY, IMMERSION 5kW/240VAC
12	3	1053.00052.00	THERMOSTAT, SINGLE SHOT, SCREW CONNECTIONS, 240V/25A
13	6	1082.00136.00	BRASS SCREW, #8-32 X 1/4", PHILLIPS PAN HEAD
14	24	1083.00009.00	WASHER, #6 SCREW, INTL TOOTH LOCKWASHER
15	24	1084.00010.00	NUT, HEX, #6-32, UNDERSIZED, ZINC PLATED
16	3	1003.00140.00	ALUMINUM BRACKET FOR SSR
17	3	1052.00033.00	RELAY, SOLID STATE, 50A/480VAC, W/BUILD IN VARISTOR
18	6	1081.00042.00	STANDOFF, 1/4" HEX
19	1	1044.00004.00	LABEL, DANGER, HIGH VOLTAGE
20	1	1022.00033.00	INSULATION, TANK, BACK, CBS-2062e
21	1	1022.00086.00	INSULATION TANK FRONT, CBS-2162 XTS



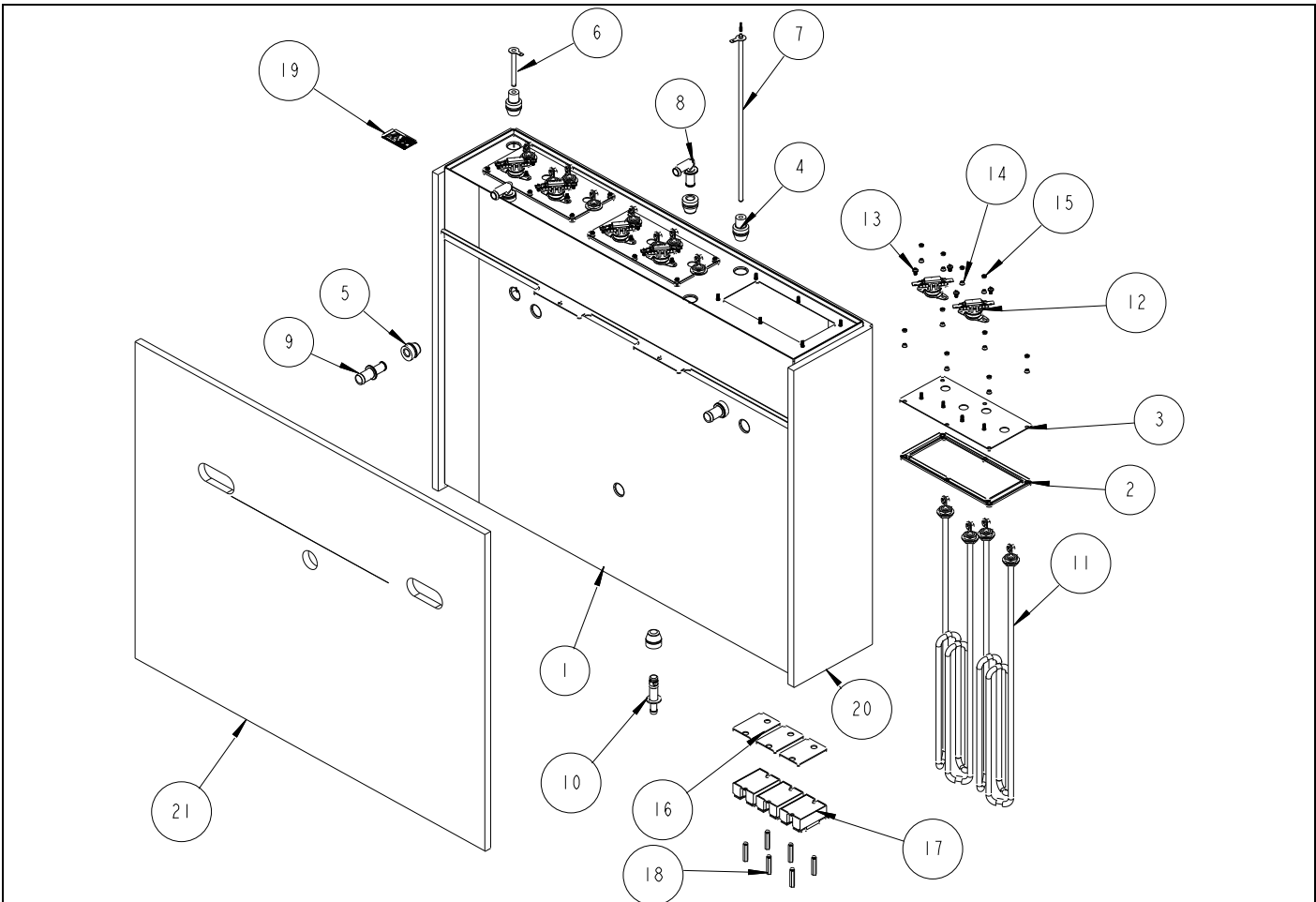

CBS-1262 Hot Water Tank six heater drawings 1104.00193.00, 1104.00195.00, 1104.00196.00

#	QTY	PART NO	DESCRIPTION
1	1	1114.00175.00	WELDMENT, TANK, CBS-12/2262
2	3	1024.00114.00	TANK GASKET - NG HEATER PLATE, TWO ELEMENT
3	3	1114.00176.00	WELDMENT TANK HEATER BRACKET, NG-LARGE, ONE HEATER
4	2	1024.00053.00	LEVEL AND TEMP PROBE GROMMET
5	5	1024.00050.00	GROMMET, SILICONE, 11.4mm ID
6	1	1112.00019.00	PROBE WELDMENT, WATER LEVEL 2.600" LG
7	1	1102.00234.00	PROBE ASSEMBLY, TEMP. AND LLC 12" LONG
8	2	1023.00212.00	FITTING, ELBOW, GROMMET, .500"
9	2	1023.00203.00	FITTING, STRAIGHT, GROMMET, .625"
10	1	1023.00166.00	FITTING, COLD WATER INLET, GROMMET DESIGN
11	6	1107.00005.00	HEATER ASSEMBLY, IMMERSION 3kW/240VAC
11	6	1107.00010.00	HEATER ASSEMBLY, IMMERSION 4kW/240VAC
11	6	1107.00032.00	HEATER ASSEMBLY, IMMERSION 5kW/240VAC
12	6	1053.00052.00	THERMOSTAT, SINGLE SHOT, SCREW CONNECTIONS, 240V/25A
13	12	1082.00136.00	BRASS SCREW, #8-32 X 1/4", PHILLIPS PAN HEAD
14	30	1083.00009.00	WASHER, #6 SCREW, INTL TOOTH LOCKWASHER
15	30	1084.00010.00	NUT, HEX, #6-32, UNDERSIZED, ZINC PLATED
16	3	1003.00140.00	ALUMINUM BRACKET FOR SSR
17	3	1052.00033.00	RELAY, SOLID STATE, 50A/480VAC, W/BUILD IN VARISTOR
18	6	1081.00042.00	STANDOFF, 1/4" HEX
19	1	1044.00004.00	LABEL, DANGER, HIGH VOLTAGE
20	1	1022.00033.00	INSULATION, TANK, BACK, CBS-2062e
21	1	1022.00086.00	INSULATION TANK FRONT, CBS-2162 XTS



## Modular Brew Head and Bypass Valves

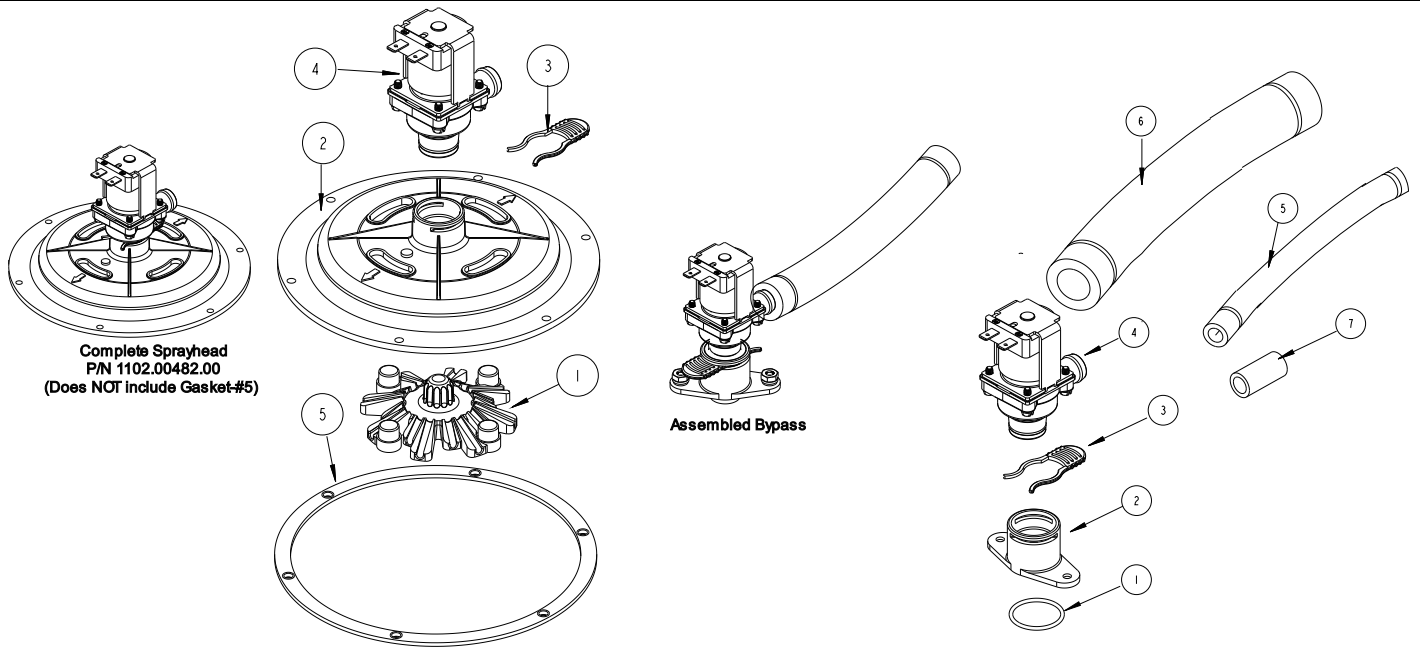

### Modular Spray Head

#	QTY	PART NO	DESCRIPTION
1	1	1102.00043.00	CASCADE SPRAY DOME, CBS-2050/60'S
2	1	1000.00145.00	QUICK CONNECT LARGE SPRAYHEAD, MODULE
3	1	1023.00342.00	QUICK CONNECT CLIP
4	1	1057.00076.00	VALVE ASSEMBLY, COMPLETE, NG, DELTROL
5	1	1024.00113.00	LARGE SPRAYHEAD GASKET

### Modular Bypass Valve

#	QTY	PART NO	DESCRIPTION
1	1	1024.00002.00	O RING, 15/16 X 1/16 CS, DASH #019
2	1	1023.00396.00	BASE, QUICK CONNECT BYPASS/VENT, RETROFIT
3	1	1023.00342.00	QUICK CONNECT CLIP
4	1	1057.00076.00	VALVE ASSEMBLY, COMPLETE, NG, DELTROL
5	1	1025.00098.00	TUBE, 5/8"OD X 3/8"ID X 11.25"L
6	1	1022.00087.00	INSULATION, 5/8" ID X 3/8" TH, 11"LG
7	1	1025.00138.00	TUBE, SILICONE, 3/4" OD X 1/2" ID X 1-1/2" LG, HOT WATER

# Wiring Diagrams

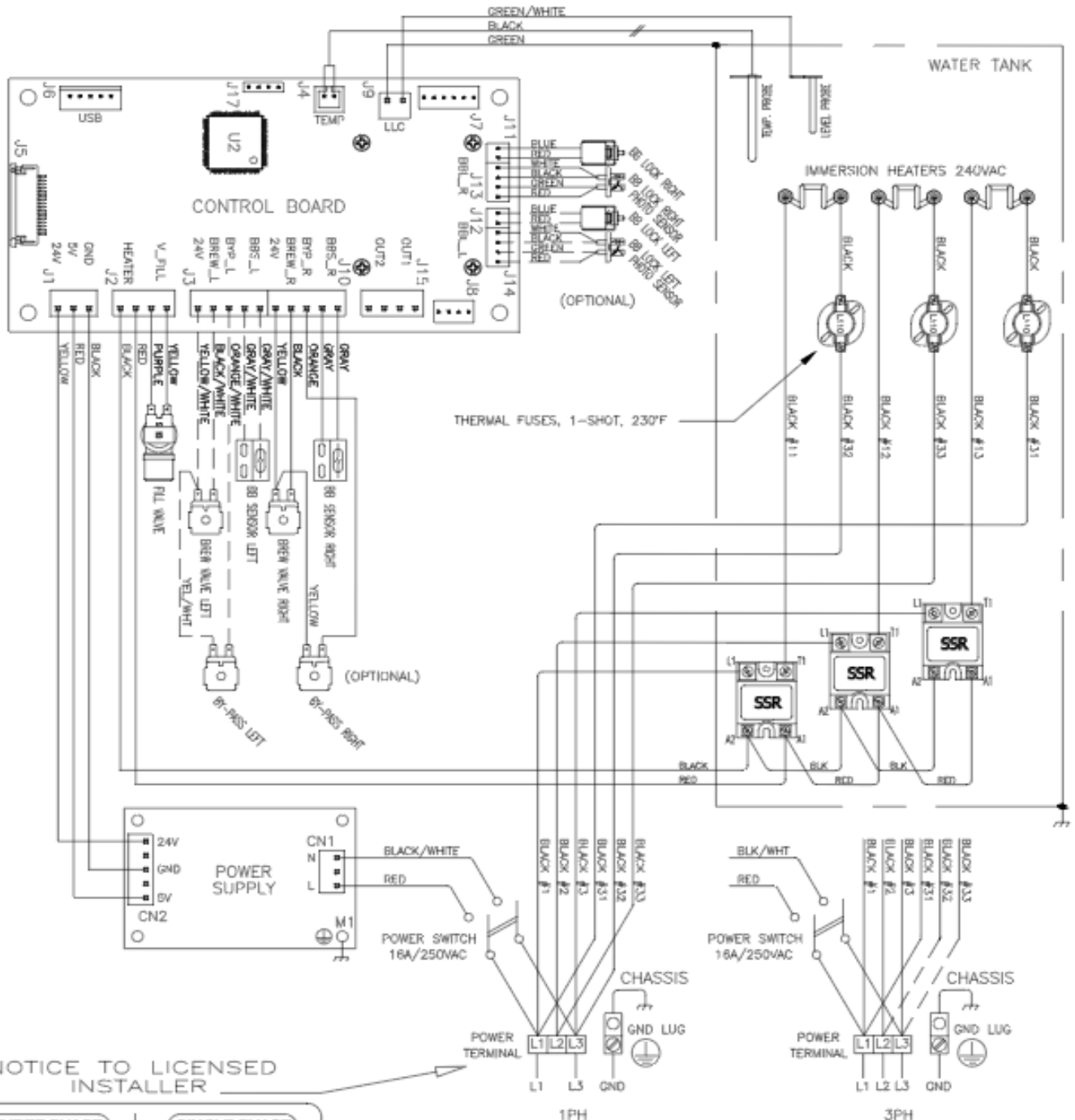

NOTICE TO LICENSED INSTALLER

THREE PHASE	SINGLE PHASE
POWER L1, L2, & L3	POWER L1 & L3 L2 - NOT CONNECTED
L1 - #1, #31	L1 - #1, #31
L2 - #2, #32	L2 - #2, #33
L3 - #3, #33	L3 - #3, #32

POWER TERMINAL CONNECTION

GBS-1261plus & CBS-1262plus Field configurable wiring  
 Field configurable models are shipped in single phase configuration  
 To change to three phase configuration: switch black wire 32 & 33  
 (Move wire 32 from L3 to L2. Move wire 33 from L2 to L3)

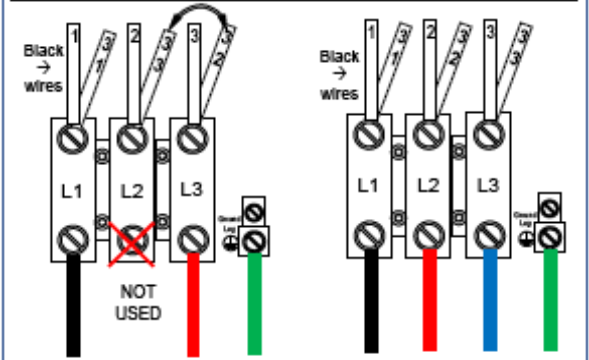

**FETCO** FOOD EQUIPMENT TECHNOLOGY COMPANY  
 830 ROSS AVE.  
 LAKE TUBAC, AZ 85647  
 PHONE: 520-718-3000, FAX: 520-718-4001  
 WWW.FETCO.COM

DWG. NAME: WIRING DIAGRAM, CBS-1200-PLUS, 3 HEATERS, UNIVERSAL,  
 (L1, (L2), L3 + GND), 1 OR 3-PH, 200-240VAC, UL  
 DRAWING NO. 1401.00179.10

- FOR SKU
- E1261IN-3C350-MM110
  - E1261IN-3C340-MM110
  - E1261IN-3C330-MM110
  - E1261KS-3C330-MM110
  - E1261BR-3C350-MM110

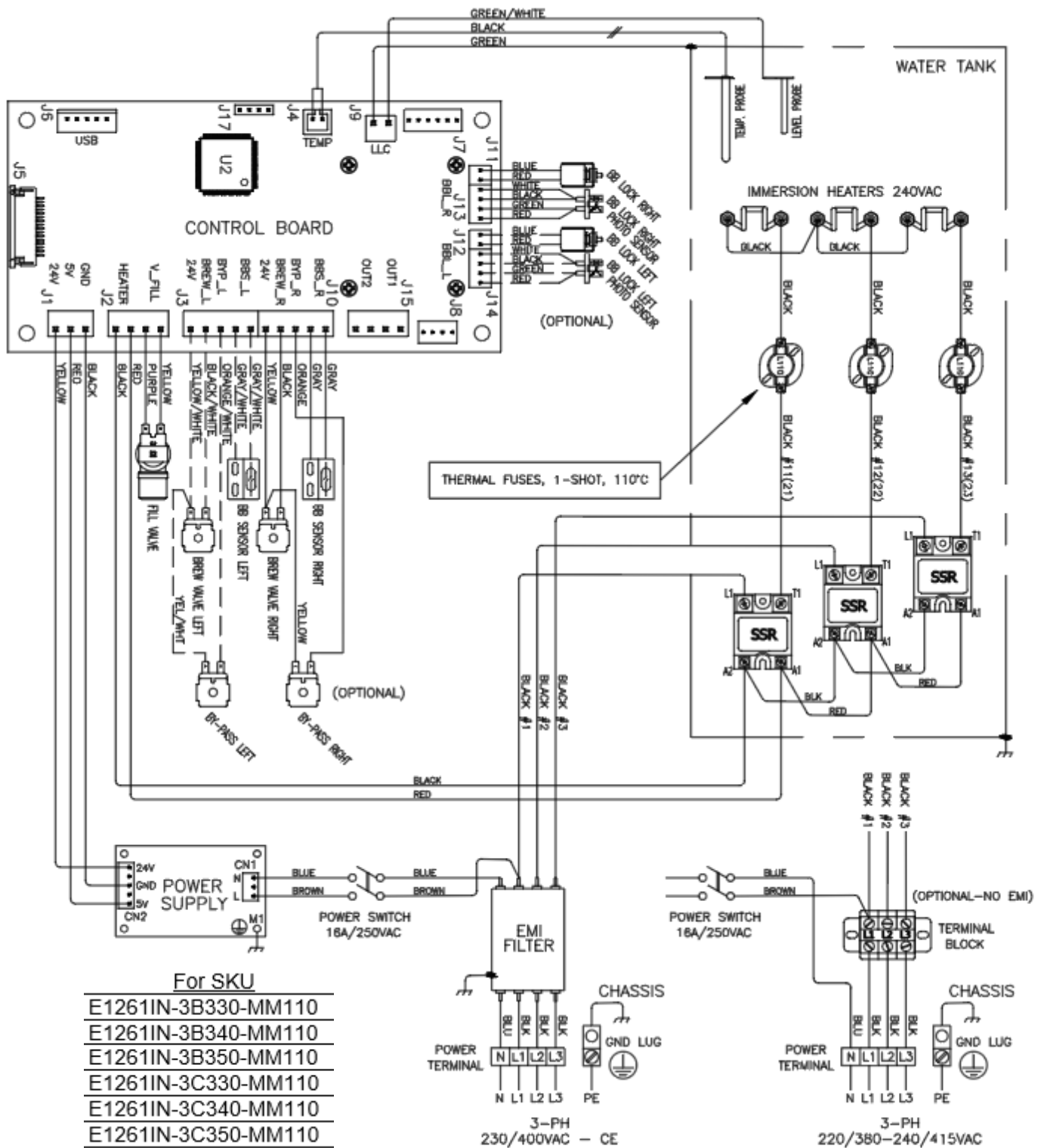

**NOTE:**  
 DASHED LINE CIRCUITS (---) DO NOT APPLY TO SINGLE UNIT.

**FETCO**® FOOD EQUIPMENT TECHNOLOGY COMPANY  
 800 ROSE RD.  
 LAKE ZURICH, IL 60047  
 PHONE: 847-719-3000, FAX: 847-719-3001  
 WWW.FETCO.COM

DWG. NAME:  
 WIRING DIAGRAM, CBS-1200-PLUS, 3 HEATERS,  
 3L-N-PE, 220/380-240/415VAC, INTERNATIONAL/CE.  
 DRAWING NO. 1401.00191.10

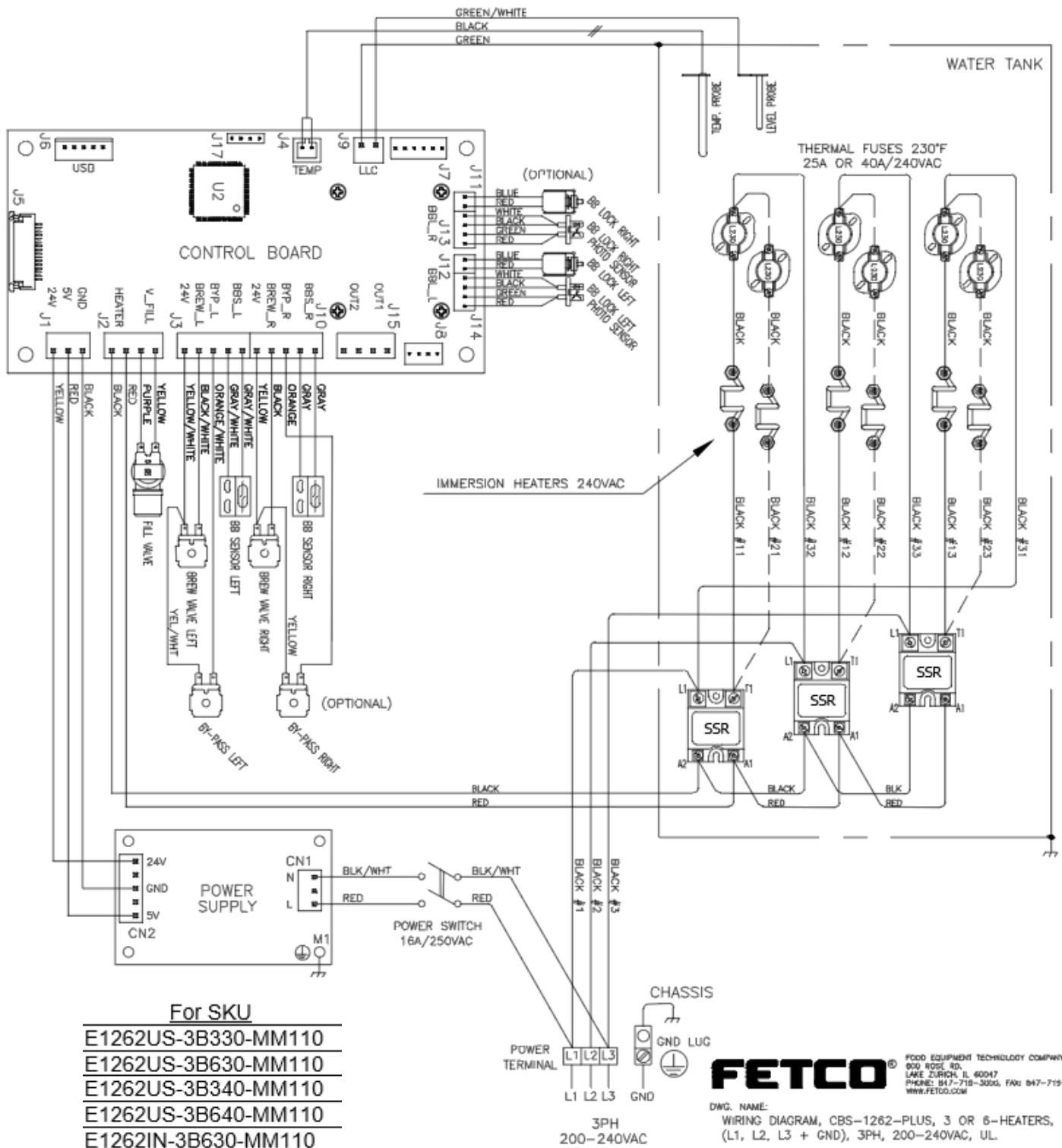

SKU	TABLE of AUTHORITIES P214	Tank	Wiring diagram
E1261US-UB230-MM110	CBS-1261, 1 or 3Ph, 3+G, 3x3kW/240VAC	1104.00199.00	1401.00179.10
E1261IN-3C350-MM110	CBS-1261, INTL, 3Ph, 220/380-240/415VAC, 3L-N-PE, 3x5kW/240VAC	1104.00201.00	1401.00191.10
E1261IN-3C340-MM110	CBS-1261, INTL, 3Ph, 220/380-240/415VAC, 3L-N-PE, 3x4kW/240VAC	1104.00200.00	1401.00191.10
E1261IN-3C330-MM110	CBS-1261, INTL, 3Ph, 220/380-240/415VAC, 3L-N-PE, 3x3kW/240VAC	1104.00199.00	1401.00191.10
E1261NM-3B350-MM110	CBS-1261, NOM, 3Ph, 3+G, 3x5kW/240VAC	1104.00201.00	1401.00179.10
E1261KS-3C330-MM110	CBS-1261, KSA, 3Ph, 220/380VAC, 3L-N-PE, 3x3kW/240VAC	1104.00199.00	1401.00191.10
E1261JP-UB230-MM110	CBS-1261, 1 or 3Ph, 200VAC, 3+G, 3x3kW/240VAC	1104.00199.00	1401.00179.10
E1261BR-3C350-MM110	CBS-1261, BR, 3Ph, 220/380-240/415VAC, 3L-N-PE, 3x5kW/240VAC	1104.00201.00	1401.00191.10
E1261CE-3C340-MM110	CBS-1261, CE, 3Ph, 230/400VAC, 3L-N-PE, 3x4kW/240VAC	1104.00200.00	1401.00191.10
E1261CE-3C330-MM110	CBS-1261, CE, 3Ph, 230/400VAC, 3L-N-PE, 3x3kW/240VAC	1104.00199.00	1401.00191.10
E1262US-3B640-MM110	CBS-1262, 3Ph, 208-240VAC, 3+G, 6x4kW/240VAC	1104.00195.00	1401.00184.10
E1262US-3B630-MM110	CBS-1262, 3Ph, 208-240VAC, 3+G, 6x3kW/240VAC	1104.00193.00	1401.00184.10
E1262US-3B340-MM110	CBS-1262, 3Ph, 208-240VAC, 3+G, 3x4kW/240VAC	1104.00194.00	1401.00184.10
E1262US-3B330-MM110	CBS-1262, 3Ph, 208-240VAC, 3+G, 3x3kW/240VAC	1104.00192.00	1401.00184.10
E1262NM-3B640-MM110	CBS-1262, NOM, 3Ph, 208-240VAC, 3+G, 6x4kW/240VAC	1104.00195.00	1401.00184.10
E1262NM-3B630-MM110	CBS-1262, NOM, 3Ph, 208-240VAC, 3+G, 6X3kW/240VAC	1104.00193.00	1401.00184.10
E1262KS-3C630-MM110	CBS-1262, KSA, 3Ph, 220/380VAC, 3L-N-PE, 6X3kW/240VAC	1104.00193.00	1401.00184.10
E1262JP-3B630-MM110	CBS-1262, 3Ph, 200VAC, 3+G, 6x3kW/240VAC	1104.00193.00	1401.00184.10
E1262IN-3C350-MM110	CBS-1262, INTL, 3Ph, 220/380-240/415VAC, 3L-N-PE, 3x5kW/240VAC	1104.00196.00	1401.00191.10
E1262CE-3C350-MM110	CBS-1262, CE, 3Ph, 230/400VAC, 3L-N-PE, 3x5kW/240VAC	1104.00196.00	1401.00191.10
E1262CE-3C340-MM110	CBS-1262, CE, 3Ph, 230/400VAC, 3L-N-PE, 3x4kW/240VAC	1104.00194.00	1401.00191.10

