

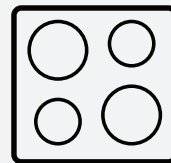

*Thinking of you*  
**Electrolux**



.....  
User manual

.....  
Gas cooktops

.....  
EHG313BA EHG643BA  
EHG643SA EHG645SA  
EHG755SA EHG953SA  
EHG953BA EHG955SA

## WE'RE THINKING OF YOU

Thank you for purchasing an Electrolux appliance. You've chosen a product that brings with it decades of professional experience and innovation. Ingenious and stylish, it has been designed with you in mind. So whenever you use it, you can be safe in the knowledge that you'll get great results every time. Welcome to Electrolux.

## BEFORE USING YOUR APPLIANCE

Before you use the cooktop, we recommend that you read through the whole user manual which provides the description of the cooktop and its functions. To avoid the risks that are always present when you use a gas appliance, it is important that the cooktop is installed correctly and that you read the safety instructions carefully to avoid misuse and hazards.

For future reference, please store this booklet in a safe place.

This appliance complies with the requirements of Australian Standard AS 4551.

## CONDITIONS OF USE

This appliance is intended to be used in household and similar applications such as:

- Staff kitchen areas in shops, offices and other working environments
- Farm houses
- By clients in hotels, motels and other residential type environments
- Bed and breakfast type environments.

## BEFORE YOU CALL

Please ensure you read the instruction manual fully before you call for service, or a full service fee could be applicable.

## RECORD MODEL AND SERIAL NUMBER HERE:

Model: \_\_\_\_\_

Serial No: \_\_\_\_\_

## CONTENTS

3	<b>General warnings</b>
4	<b>Part names</b>
8	<b>Using your cooktop</b>
9	<b>Burners</b>
10	<b>Cleaning and care</b>
11	<b>Troubleshooting</b>
12	<b>Technical data</b>
14	<b>Installation instructions</b>
18	<b>Installation procedure</b>
23	<b>Gas connection</b>
24	<b>LP conversion</b>
26	<b>Electrical connection</b>
27	<b>Testing appliance operation</b>
29	<b>Warranty</b>

## LEGEND

### **WARNING!**

This symbol indicates information concerning your personal safety.

### **CAUTION!**

This symbol indicates information on how to avoid damaging the cooktop.

### **IMPORTANT!**

This symbol indicates tips and information about use of the cooktop.

### **ENVIRONMENT!**

This symbol indicates tips and information about economical and ecological use of the cooktop.

## INFORMATION ON DISPOSAL FOR USERS

### **ENVIRONMENT!**

- Most of the packaging materials are recyclable. Please dispose of these materials through your local recycling depot or by placing them in appropriate collection containers.
- If you wish to discard this product, please contact your local authorities and ask for the correct method of disposal.

## GENERAL WARNINGS

Please read the user manual carefully and store in a handy place for later reference. Pass the user manual on to possible new owners of the cooktop.

Read the following carefully to avoid damage or injury.

 **This symbol indicates never to do this**

 **This symbol indicates always do this**

### **WARNING!**















- Do not allow pots to boil dry, as damage to both pan and cooktop may result.
- Do not operate the cooktop for an extended period of time without a pot or pan on the burner.
- Do not allow large cookware to overhang the cooktop onto adjacent benchtop. This will cause scorching to the benchtop surface.
- Do not allow cooking pots or pans to intrude into the area which is close to the controls.
- Ensure burner bodies and trivets are properly located (see Figure 3).

*NOTE! You must read these warnings carefully before installing or using the cooktop. If you need assistance, contact your Customer Care Department. The manufacturer will not accept liability, should these instructions or any other safety instructions incorporated in this book be ignored.*

### **CAUTION!**

**Read the following carefully to avoid an electric shock or fire.**

It is important to use your cooktop safely. Check these safety points before using your cooktop.

- |   |   |
|---|---|
|    | This appliance is not intended for use by persons (including children) with reduced physical, sensory or mental capabilities, or lack of experience and knowledge, unless they have been given supervision or instruction concerning use of the appliance by a person responsible for their safety. |
|    | Children should be supervised to ensure they do not play with this appliance.   |
|    | During use, this appliance becomes hot. Care should be taken to avoid touching hot surfaces. To avoid burns, young children should be kept away.  |
|    | This appliance must not be used as a space heater.  |
|    | Keep vents clear of obstructions.   |
|    | In order to avoid a fire, this appliance must be kept clean.  |
|    | Do not spray aerosols in the vicinity of this appliance while it is in operation.   |
|  | Do not store flammable materials on or under this appliance, e.g. aerosols.   |
|  | Do not remove the trivet and enclose the burner with a wok stand as this will concentrate and deflect heat onto the burner.   |
|  | Do not use large pots or heavy weights which can bend the trivet or deflect flame onto the burner.  |
|  | Do not place anything, e.g. asbestos mat between pan and trivet as serious damage to the cooktop may occur.   |
|  | For maximum stability, ensure pots and pans are centrally located on the trivets.   |
|  | Handles should be turned away from the front of the bench to avoid accidents.   |
|  | Do not modify this appliance.   |
|  | Only models fitted with flame safeguard can be used in marine craft, caravans or mobile homes.  |

## PART NAMES

## Description of the burner

Figure 1a

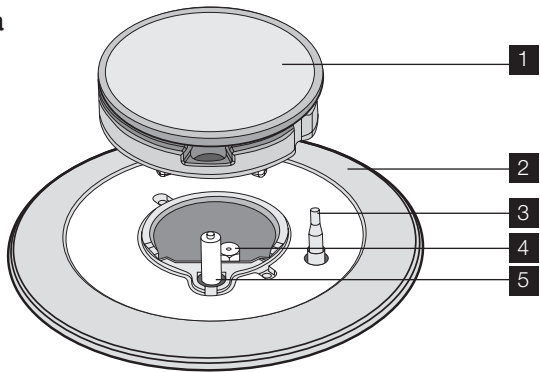

- |                          |                       |
|--------------------------|-----------------------|
| 1 Burner                 | 4 Injector            |
| 2 Skirt                  | 5 Ignition spark plug |
| 3 Flame safeguard sensor |                       |

Figure 1b

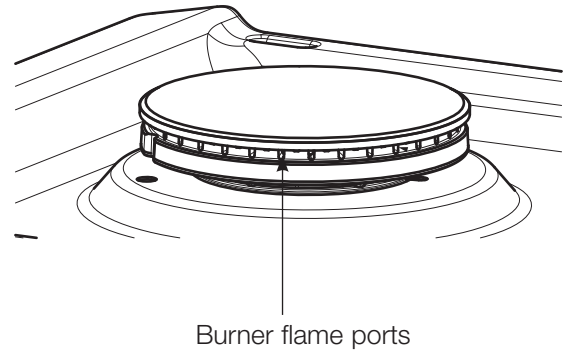

Burner flame ports

Figure 2a

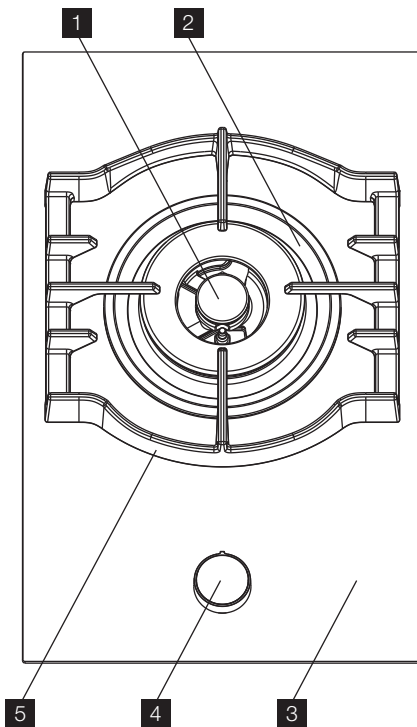

## EHG313BA

- |  |
|--|
| 1 Dual wok burner  |
| 2 Enamelled burner skirt   |
| 3 Ceramic Glass hob – the glass hob is resistant to heat, cold and rapid temperature changes, but is vulnerable to impact. A pepper mill falling on the hob could crack it. Never stand or put heavy loads on the hob, or use as a storage space |
| 4 Control knob   |
| 5 Removable cast iron trivet (left)  |

Figure 2b

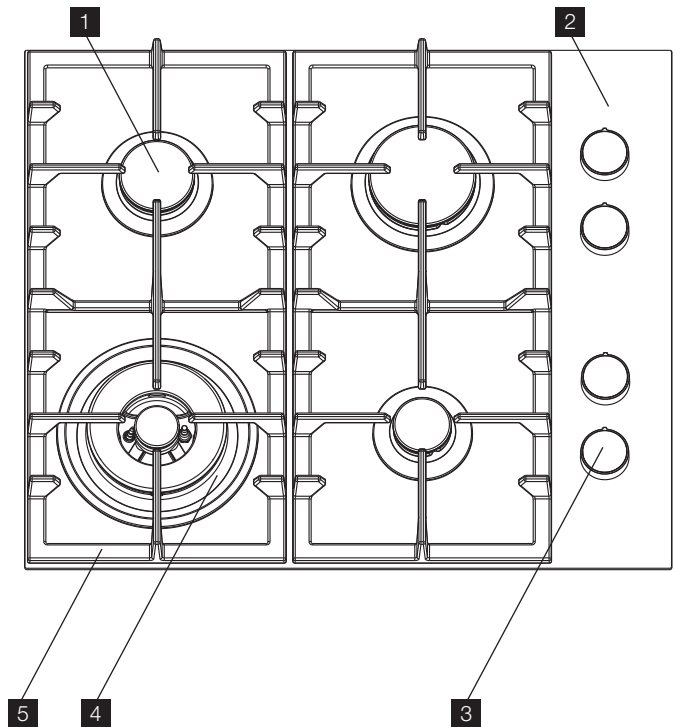

## EHG643BA

- |  |
|--|
| 1 Burners – this unit has a small, medium, large and dual wok burner   |
| 2 Ceramic Glass hob – the glass hob is resistant to heat, cold and rapid temperature changes, but is vulnerable to impact. A pepper mill falling on the hob could crack it. Never stand or put heavy loads on the hob, or use as a storage space |
| 3 Control knob   |
| 4 Enamelled burner skirts  |
| 5 Removable cast iron trivet (2 per)   |

Figure 2c

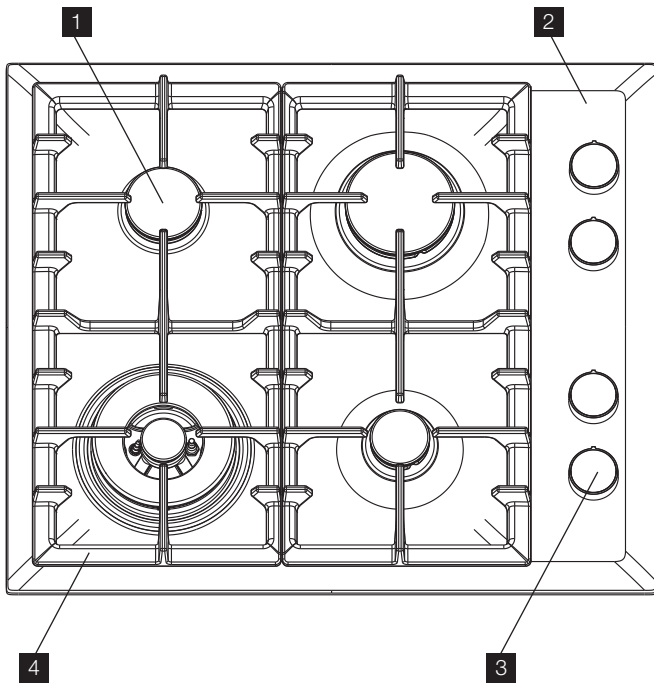
**EHG643SA**

- 1 Burners – this unit has a small, medium, large and dual wok burner
- 2 Stainless Steel hob
- 3 Control knob
- 4 Removable cast iron trivet (2 per)

Figure 2d

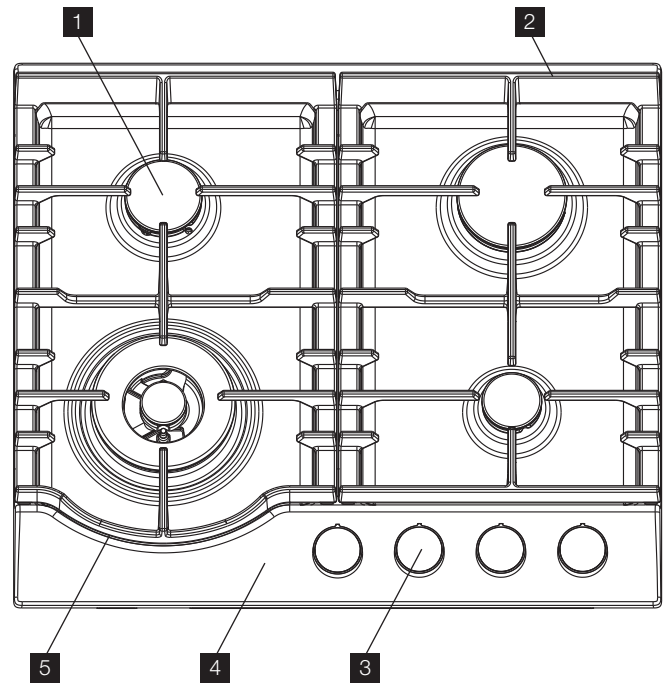
**EHG645SA**

- 1 Burners – this unit has a small, medium, large and dual wok burner
- 2 Removable cast iron trivet (right)
- 3 Control knob
- 4 Stainless Steel hob
- 5 Removable cast iron trivet (left)

Figure 2e

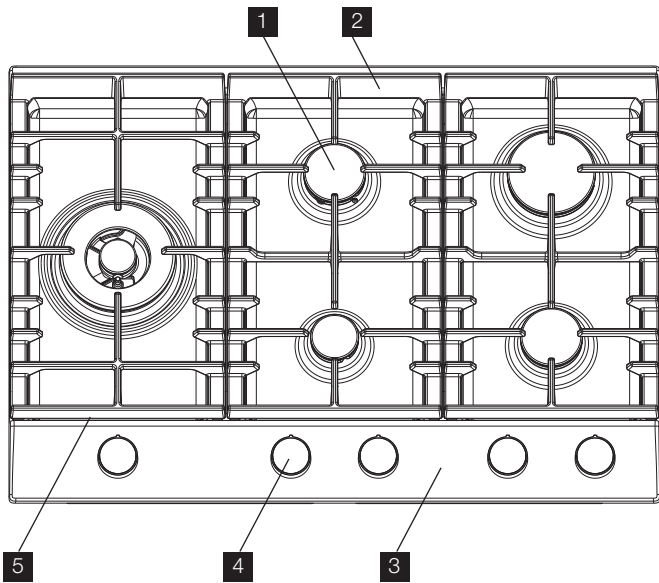
**EHG755SA**

- 1 Burners – this unit has a small, medium (2 per), large and dual wok burner
- 2 Removable cast iron trivet (2 per) for centre and right
- 3 Stainless Steel hob
- 4 Control knob
- 5 Removable cast iron trivet (left)

Figure 2f

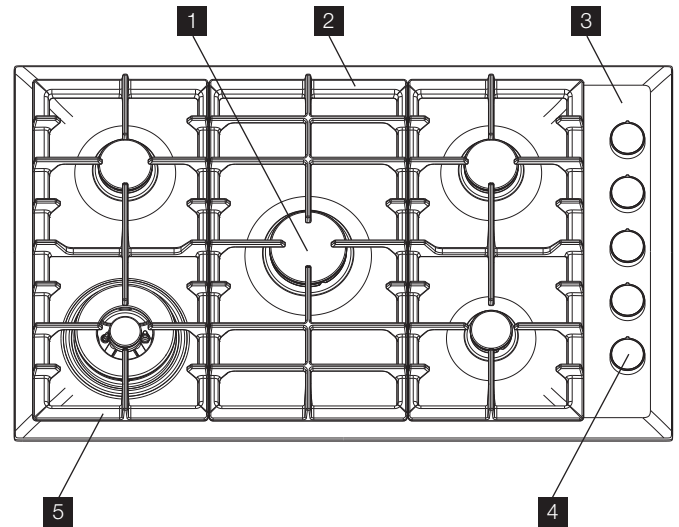
**EHG953SA**

- 1 Burners – this unit has a small, medium (2 per), large and dual wok burner
- 2 Removable cast iron trivet for centre
- 3 Stainless Steel hob
- 4 Control knob
- 5 Removable cast iron trivet (2 off for left and right)

Figure 2g

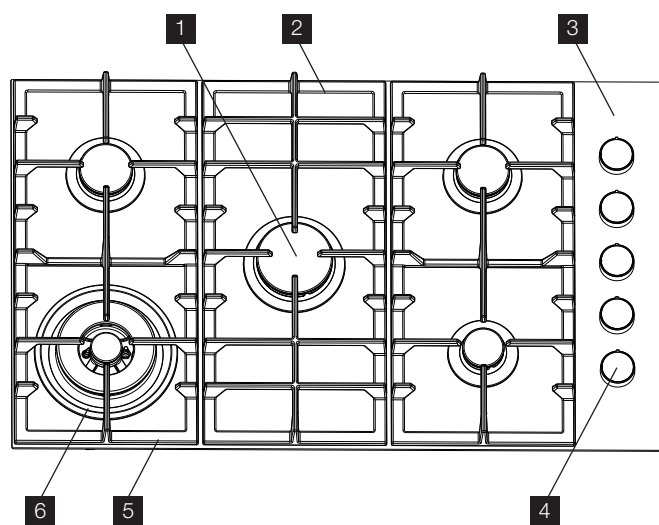
**EHG953BA**

- 1 Burners – this unit has a small, medium (2 per), large and dual wok burner
- 2 Removable cast iron trivet for centre
- 3 Ceramic Glass hob – the glass hob is resistant to heat, cold and rapid temperature changes, but is vulnerable to impact. A pepper mill falling on the hob could crack it. Never stand or put heavy loads on the hob, or use as a storage space
- 4 Control knob
- 5 Removable cast iron trivet (2 off for left and right)
- 6 Enamelled burner skirts

Figure 2h

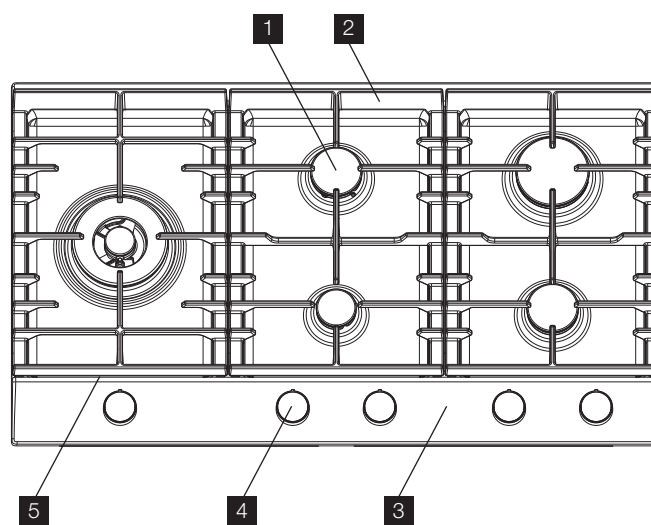
**EHG955SA**

- 1 Burners – this unit has a small, medium (2 per), large and dual wok burner
- 2 Removable cast iron trivet (2 per) for centre and right
- 3 Stainless Steel hob
- 4 Control knob
- 5 Removable cast iron trivet (left)

Figure 3

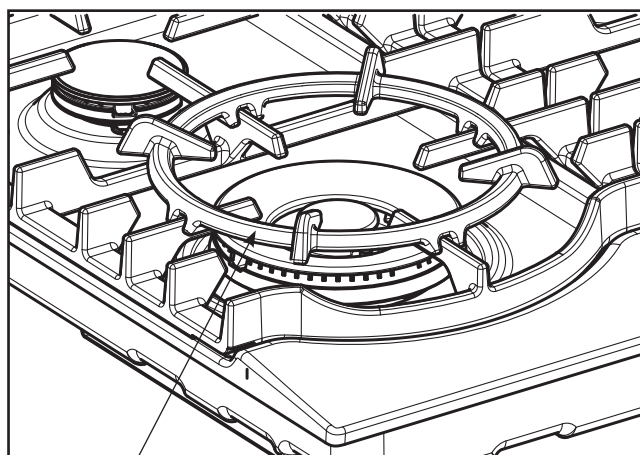

Wok support trivet

## USING YOUR COOKTOP

### Installation

- An authorised person must install this appliance and **MUST provide a Certificate of Compliance.** This certificate should be retained along with purchase information.
- Before using the appliance, ensure that all packing materials are removed from the appliance.
- In order to avoid any potential hazard, the installation instructions in this booklet, and any labels on the appliance must be followed.
- Ensure that all specified vents, openings and air spaces are not blocked.
- Where the appliance is built into a benchtop, the benchtop material must be capable of withstanding 85°C.
- Ensure that the duplicate rating label (in the instruction pack) is attached to a readily accessible adjacent surface, so that the cooktop can be easily identified in the case of a service call.

### Servicing

- Servicing **MUST** only be carried out by authorised personnel.
- To maintain safe operation, it is recommended that the product be inspected every five years by an authorised service person.
- If the supply cord is damaged, it must be replaced by the manufacturer, its service agent or similarly qualified persons in order to avoid a hazard.

### Cleaning

- Always ensure the appliance is turned off before cleaning.
- This appliance contains aluminium fittings.  
**Do not use caustic based cleaners.**
- Do not use steam cleaners as this may cause moisture build up on electrical components.
- Always clean the appliance immediately after any food spillage.
- Do not place any components in a dishwasher.
- Refer to page 10 for care and cleaning instructions for stainless/ ceramic hob panel.

### CAUTION!

- Do not place burners in a dishwasher.
- Do not place trivets in the dishwasher.

### Controls

Each burner is controlled by a control knob. The markings on the control panel indicate which burner the knob controls, and the setting for that burner (see Figure 4).

Figure 4

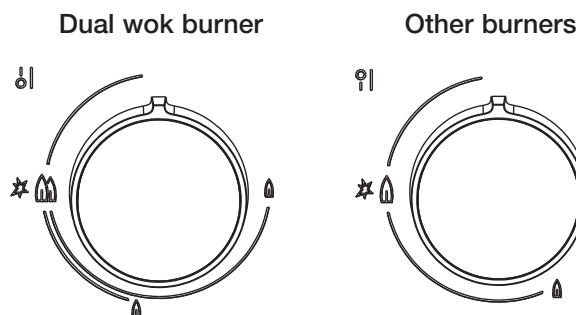



*NOTE! Gas controls turn anticlockwise from 'OFF' and have limited movement.*

### Lighting burners

Electronic ignition: These cooktops are fitted with mains powered ignition. When the appliance has been connected and the power is on, depressing any knob will release sparks to all burners.

### CAUTION!

- Keep hands clear of burners when lighting.
- If burner does not light within 5 seconds, turn knob to 'OFF' position, allow gas to disperse, then try lighting again.
- Burners **MUST** be operated between 'HIGH' and 'LOW' settings only.

To light a burner, the knob must be turned to the  or  'HIGH' position, then pushed down as far as possible for approximately 5 seconds. If the flame goes out when the knob is released simply depress the knob again, this time holding it down with slightly more force for the same length of time.

The height of the flame can be varied by turning the control knob toward the  'LOW' position.

*NOTE! When the wok burner is turned to low only the small inner ring stays lit. This is a normal function of the dual wok burner to provide a very low power flame option.*

In the absence of electrical power, carry out the ignition directly to the burner with a hand held ignition source.

## BURNERS

### Choice of burner

For your convenience there is a choice of burners:

- A small burner for special low heat and slow cooking.
- A medium burner for normal cooking and simmering (one on the four burner models and two on the five burner models).
- A large burner for fast heating and large pots and pans.
- A wok burner for very fast heating using a wok or large pot or pan. This wok burner is also a “dual” burner and therefore results in a small low powered flame when the burner is turned down. This is achieved by only supplying gas to the inner ring of the wok burner.

To conserve gas place the pan centrally over the burner and adjust the flame so that it does not extend past the edge of the pan (Figure 5). Do not boil food too rapidly. A vigorous boil will not cook food any faster, and will waste energy.

### Pots and pans

All common pots and pans; aluminium, stainless steel, cast iron, ceramic, etc., may be used on your new gas cooktop. Ensure that the pots or pans are steady and have flat bases to avoid dangerous spill-over of hot liquids and wasted energy.

### CAUTION!

Never use asbestos mats, wire mats or grids, or aluminium foil as it can lead to overheating, cracked enamel or broken glass. The warranty will be void if these items are used and cause a failure. Woks should only be used on the wok burner and wok support trivet (refer to Figure 3 on page 7).

Figure 5

### Choice of flame height

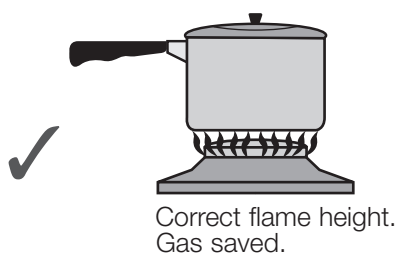

### Choice of cooking utensils

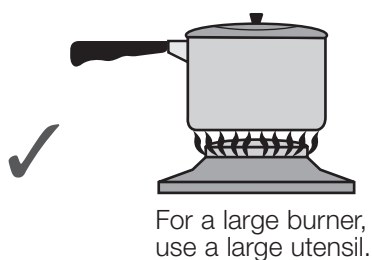

## CLEANING AND CARE



### CAUTION!

Ensure the appliance is off and cool before cleaning.

### Enamel (on burner skirts and trivets)

Persistent stains may require rubbing with a nylon scourer or creamed powder cleansers. Household enamel cleaners are available, follow the manufacturer's instructions in their use. **Harsh abrasive cleaners, powder cleaners, steel wool or wax polishes should not be used.**

### Stainless steel (*Models with Stainless Steel hob*)

Simply wipe with a soft cloth using warm water and a mild detergent and rinse with clean water. Where stainless steel has become extremely dirty or discoloured, use a stainless steel cleaner – but be sure to follow the brushing lines.



### CAUTION!

**DO NOT use abrasive cleaners or harsh solvents.**



### IMPORTANT!

**Scrapers are to be used on ceramic models only**

### Ceramic glass (*on models with glass hob*)

The specially treated glass in the product is manufactured using the latest technology to the highest possible standards for both safety and reliability. However, it must be remembered that as it is **CERAMIC GLASS**, it may break. Treat it accordingly. To clean the ceramic glass hob use a soft cloth or sponge with detergent and warm water.



### CAUTION!

If the surface is cracked, switch off the appliance immediately to avoid the possibility of electric shock.

If the hob is very soiled:

1. Remove soilage using the razor blade scraper.
2. Use a hob cleaner product after there has been sufficient time allowed for the hob to cool. Shake the bottle and apply a small quantity of cleaner directly onto the hob. Rub clean using a damp cloth or paper towels.
3. Use a damp cloth to remove all remaining traces of the cleaner, which could otherwise burn on when the hob is next used. Wipe the hob dry.



### CAUTION!

**Use the scraper supplied to remove spillages immediately, while the hob is still hot! Especially sugar and foods with a high sugar content (eg. jam), melted plastics and foil, all of which can damage the hob if left.**

### Razor blade scraper

Use the scraper to remove spillages from the ceramic hob.

### How to use the razor blade scraper:

1. Pull back the protective cover until the blade is visible.
2. Make sure that the razor blade is clean and not worn. There is a risk, otherwise, that it might damage the hob. New razor blades can be bought from pharmacies.
3. Angle scraper at approx. 45° and scrape away the spillage. The razor blade can be pressed down hard onto the hob without causing any damage.
4. Carefully clean the blade by wiping it with a paper towel.
5. When you have finished, press the protective cover forwards as far as it will go. Keep the scraper out of the reach of children.

### Changing the razor blade:

1. Open the scraper by completely unscrewing the screw and then place the new razor blade at the front edge.
2. Put the scraper together again and screw the screw back into place.
3. Press the protective cover forwards as far as it will go to cover the razor blade.



### CAUTION!

**THE RAZOR BLADE SCRAPER SHOULD BE KEPT WELL OUT OF THE REACH OF CHILDREN. Use the razor blade scraper carefully, as the razor blade is extremely sharp.**

### Trivets and burners

These can all be lifted off and removed for separate cleaning.

*NOTE! When refitting the burners, ensure that they are correctly seated.*

Ensure burners are thoroughly dried after cleaning or spillage. When cleaning the burners, ensure that all the flame ports are free of any blockage (refer to Figure 1b on page 4). If necessary, use a toothpick or brush to clear ports. The outer surface of the burner caps have a polished finish and extra care needs to be taken to avoid scratching this surface during cleaning. In instances of heavy soiling, it may be necessary to apply a non-abrasive cleaning compound and rub with a cloth until the soiling is removed and then finish with a soft, dry cloth.

*NOTE! DO NOT place trivets or burners in the dishwasher.*

### Ignition spark plug and flame safeguard sensor

**GENTLY** clean the ignition spark plug and flame safeguard sensor with a damp cloth to avoid lighting difficulties. Ensure that they are dry before use.

### Injector

Ensure the injector remains free of any foreign material. If necessary, use a thin piece of wire to clear the orifice.

## TROUBLESHOOTING

If you have a problem with the cooktop, check the table below. You may be able to solve the problem and this will save you from paying for a service call. You will have to pay for a service call even in the warranty period if the problem is one listed below.

**Table 1**

<b>problem</b>	<b>possible cause</b>	<b>solution</b>
Burner will not light even though the sparker is working	<ul style="list-style-type: none"> <li>• Knob not held down long enough in 'HIGH' position for flame safeguard.</li> <li>• Gas supply valve turned off.</li> <li>• Wrong knob turned.</li> <li>• Port blockage in ignition area.</li> <li>• Ignition spark plugs wet or dirty.</li> </ul>	<ul style="list-style-type: none"> <li>• Repeat lighting procedure and hold knob down for 5 seconds in 'HIGH' position. (Refer page 8).</li> <li>• Turn on gas supply to appliance.</li> <li>• Ensure the knob you are turning corresponds to the burner you want to light.</li> <li>• Ensure that ports in ignition area are clean and dry.</li> <li>• Dry or clean ignition spark plugs.</li> </ul>
No spark is obtained when control knob is activated	<ul style="list-style-type: none"> <li>• Electricity supply is disconnected or switched off.</li> <li>• Ignition spark plugs wet or dirty.</li> </ul>	<ul style="list-style-type: none"> <li>• Switch on electricity or check fuses.</li> <li>• Dry or clean ignition spark plugs.</li> </ul>
Flames uneven or tending to lift	<ul style="list-style-type: none"> <li>• Flame ports blocked or wet.</li> <li>• Burner cap incorrectly fitted.</li> </ul>	<ul style="list-style-type: none"> <li>• Clean or dry flame ports.</li> <li>• Ensure this component is fitted correctly.</li> </ul>
Flames not staying on when knob is released	<ul style="list-style-type: none"> <li>• Knob not held down long enough in 'HIGH' position for flame safeguard to engage.</li> <li>• Knob not set between 'HIGH' and 'LOW'</li> <li>• Dirt or spillage on flame safeguard sensor.</li> </ul>	<ul style="list-style-type: none"> <li>• Repeat lighting procedure and hold knob down for 5 seconds in 'HIGH' position. (Refer page 8).</li> <li>• Knob MUST be set between these positions.</li> <li>• Clean flame safeguard sensor tip.</li> </ul>
Low heat, slow cooking	<ul style="list-style-type: none"> <li>• Incorrect cooking pot or pan being used.</li> </ul>	<ul style="list-style-type: none"> <li>• Refer to Figure 5 (page 9).</li> </ul>
Benchtop or knobs overheating	<ul style="list-style-type: none"> <li>• Incorrect cooking pot or pan used.</li> <li>• Pot or pan not located on burner properly.</li> </ul>	<ul style="list-style-type: none"> <li>• Refer to Figure 5 (page 9).</li> <li>• Ensure pot or pan is centrally located on burner.</li> </ul>
Cooktop stainless steel discoloured	<ul style="list-style-type: none"> <li>• Pot or pan being used is too large.</li> </ul>	<ul style="list-style-type: none"> <li>• Ensure pot sizes used are as per user manual requirements. Clean with STEEL POWER (available through spare parts).</li> </ul>
Outer ring of wok burner goes out when set to low	<ul style="list-style-type: none"> <li>• This is not a failure. This is a function of the dual wok burner to give a very low power flame option.</li> </ul>	<ul style="list-style-type: none"> <li>• No remedy - burner is functioning as intended.</li> </ul>

## TECHNICAL DATA

**We reserve the right to alter these specifications.  
This appliance conforms to AS 4551.**

Table 2

<b>features</b>	<b>EHG313BA</b>	<b>EHG643BA</b>	<b>EHG643SA</b>	<b>EHG645SA</b>
Cooking zones	1	4	4	4
Wok	Yes, dual	Yes, dual	Yes, dual	Yes, dual
Ignition	220-240V	220-240V	220-240V	220-240V
Trivet	Cast	Cast	Cast	Cast
Hob material	Ceramic glass	Ceramic glass	Stainless steel	Stainless steel
Features	Ignition through knob	Ignition through knob	Ignition through knob	Ignition through knob
Flame safeguard	Yes	Yes	Yes	Yes
Colours	Black	Black	Stainless steel	Stainless steel
Gas types	NG, (LP conversion kit supplied)	NG, (LP conversion kit supplied)	NG, (LP conversion kit supplied)	NG, (LP conversion kit supplied)
<b>cooktop dimensions mm</b>				
Width	320	610	600	595
Depth	520	520	520	530
Height	56	56	45	44
<b>cut out dimensions mm</b>				
Width	303	570	570	560
Depth	485	490	490	490
<b>energy rating (NG) – MJ/h</b>				
Small burner	NA	5.1	5.1	5.1
Medium burner	NA	9.0	9.0	9.0
Large burner	NA	12.1	12.1	12.1
Wok burner	17.0	17.0	17.0	17.0
Total MJ/h	17.0	43.2	43.2	43.2

Table 2 continued

<b>features</b>	<b>EHG755SA</b>	<b>EHG955SA</b>	<b>EHG953BA</b>	<b>EHG953SA</b>
Cooking zones	5	5	5	5
Wok	Yes, dual	Yes, dual	Yes, dual	Yes, dual
Ignition	220-240V	220-240V	220-240V	220-240V
Trivet	Cast	Cast	Cast	Cast
Hob material	Stainless steel	Stainless steel	Ceramic glass	Stainless steel
Features	Ignition through knob	Ignition through knob	Ignition through knob	Ignition through knob
Flame safeguard	Yes	Yes	Yes	Yes
Colours	Stainless steel	Stainless steel	Black	Stainless steel
Gas types	NG, (LP conversion kit supplied)	NG, (LP conversion kit supplied)	NG, (LP conversion kit supplied)	NG, (LP conversion kit supplied)
<b>cooktop dimensions mm</b>				
Width	745	895	861	860
Depth	530	530	520	520
Height	44	44	55	47
<b>cut out dimensions mm</b>				
Width	730	880	830	830
Depth	490	490	470	470
<b>energy rating (NG) – MJ/h</b>				
Small burner	5.1	5.1	5.1	5.1
Medium burner	2 x 9.0	2 x 9.0	2 x 9.0	2 x 9.0
Large burner	12.1	12.1	12.1	12.1
Wok burner	17.0	17.0	17.0	17.0
Total MJ/h	52.2	52.2	52.2	52.2

## INSTALLATION INSTRUCTIONS

This appliance must be installed by an authorised person and in compliance with:

1. AS/NZS 5601.1 Gas Installations Part 1: General Installations, and AS/NZS 5601.2 Gas Installations Part 2: LP Gas installations in caravans and boats for non-propulsive purposes, or the relevant installation code for gas appliances in your country.
2. The local gas fitting regulations, municipal building codes, electrical wiring regulations and any other relevant statutory regulations.
3. The particular instructions as given below.
4. A certificate of compliance **MUST** be given to the customer after the application is successfully installed.

### **! CAUTION!**

Cooktops are supplied set up for natural gas (NG). To use on LPG, the injectors must be changed using the conversion kit supplied. Refer LP conversion on page 24-25.

**Figure 6a – EHG313BA**

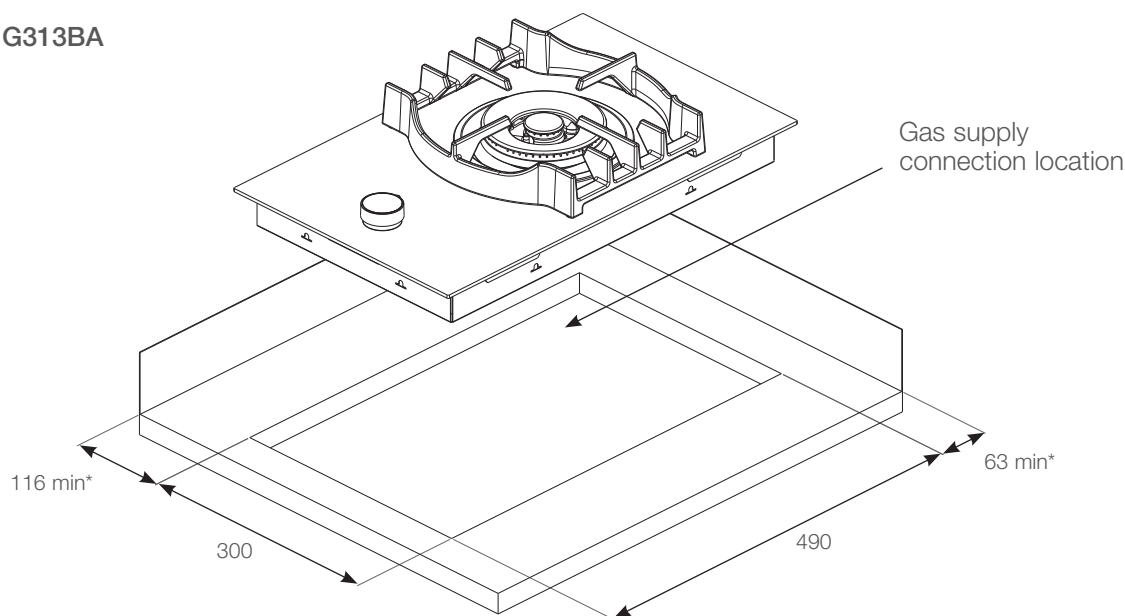

**Figure 6b – EHG643BA**

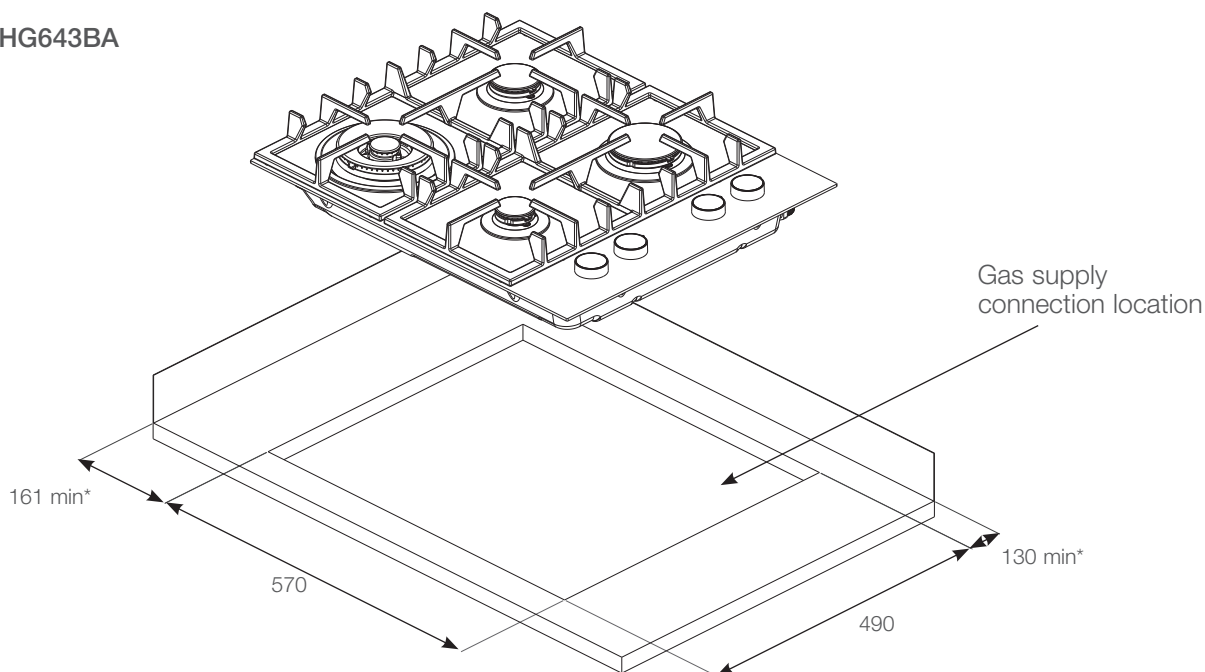

\* to combustible surface

Figure 6c – EHG643SA

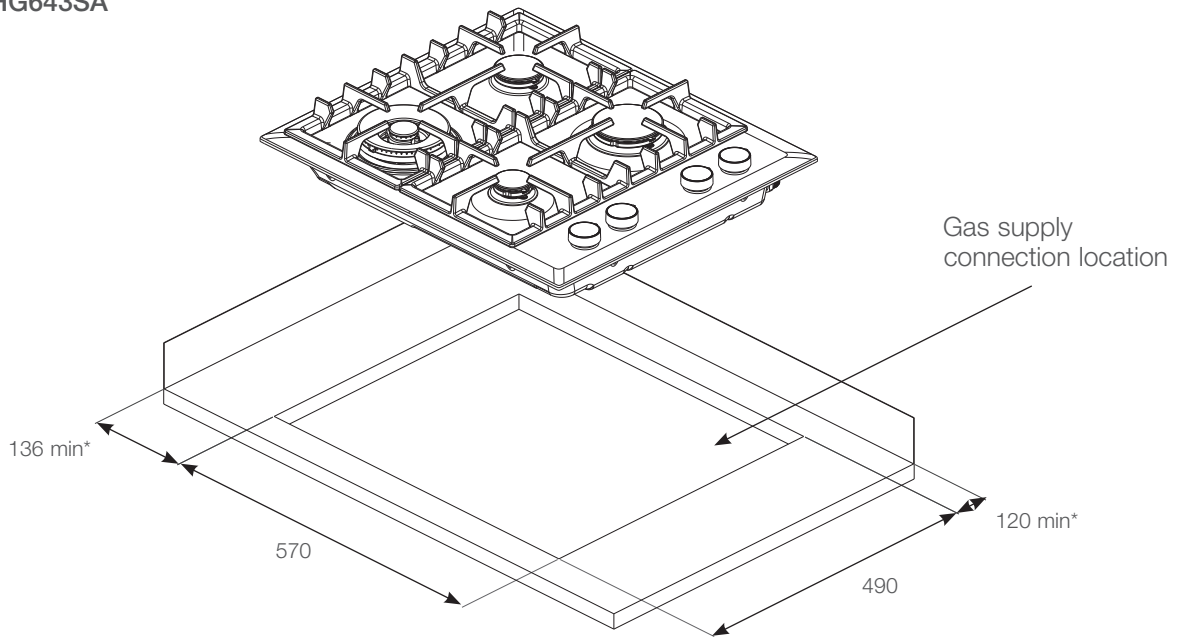
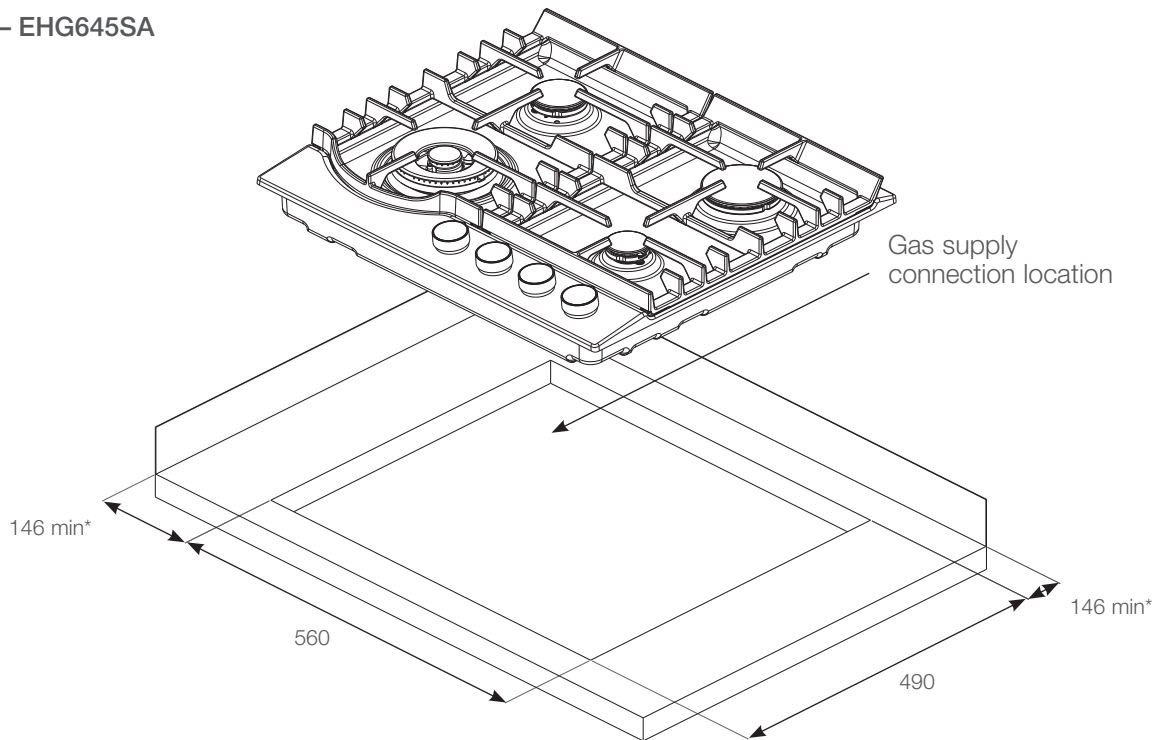

Figure 6d – EHG645SA



\* to combustible surface

Figure 6e – EHG755SA

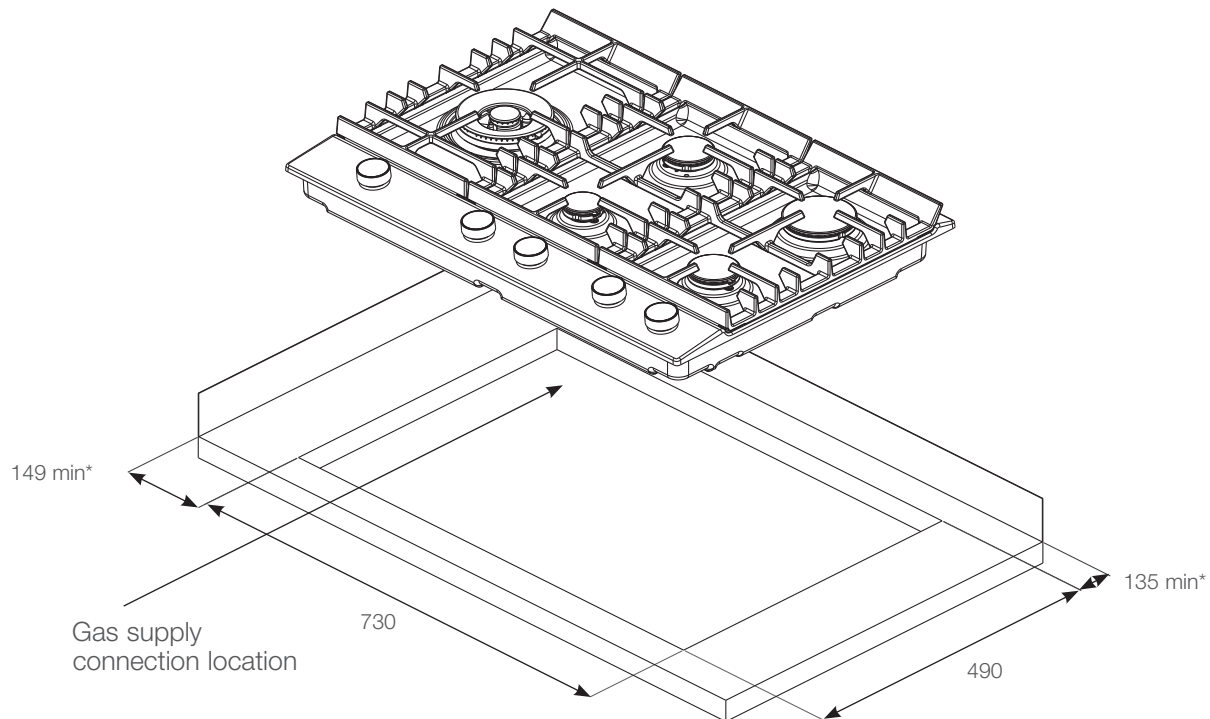
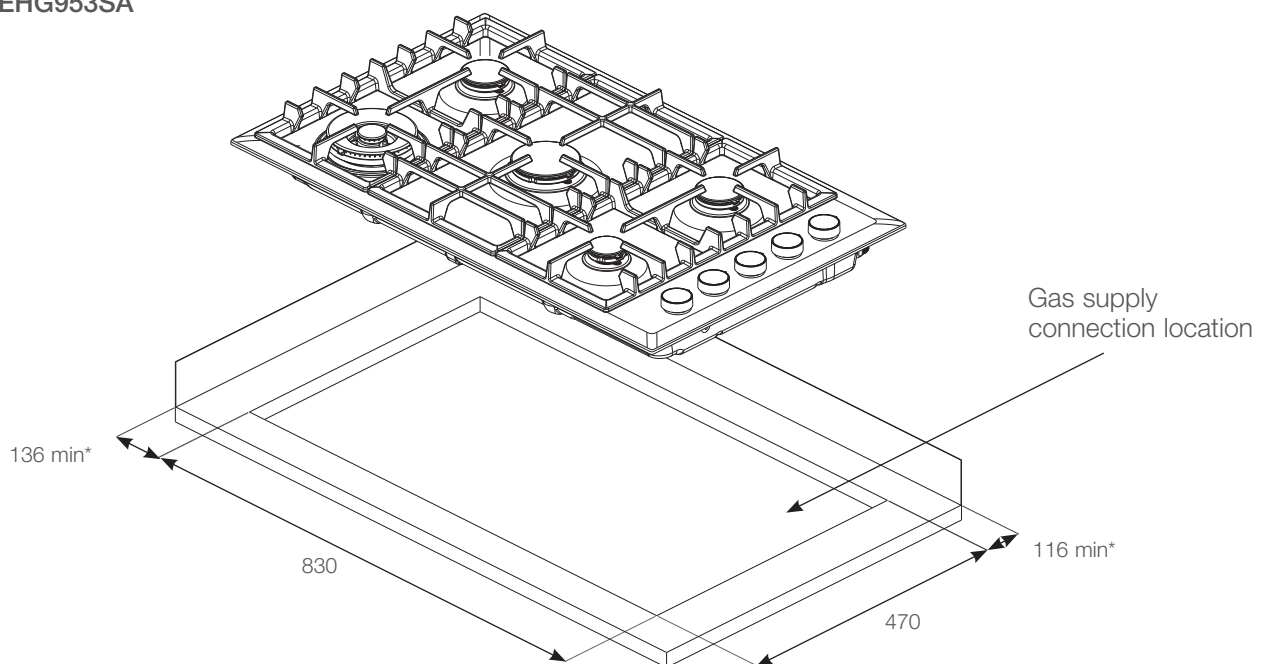

Figure 6f – EHG953SA



\* to combustible surface

Figure 6g – EHG953BA

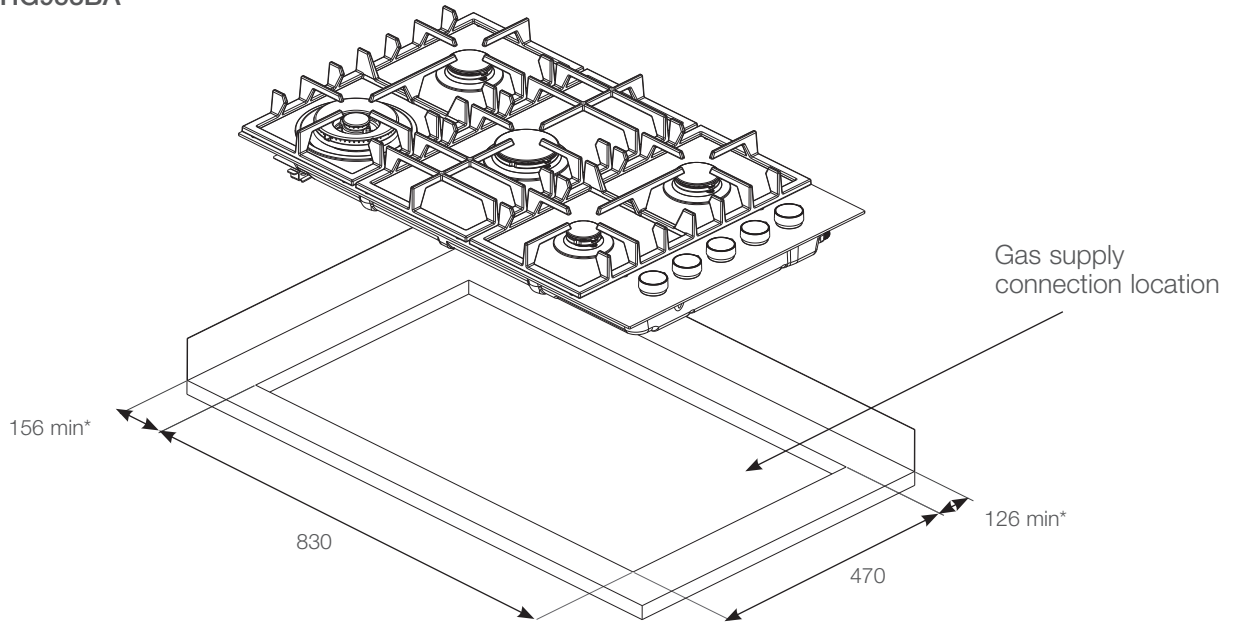
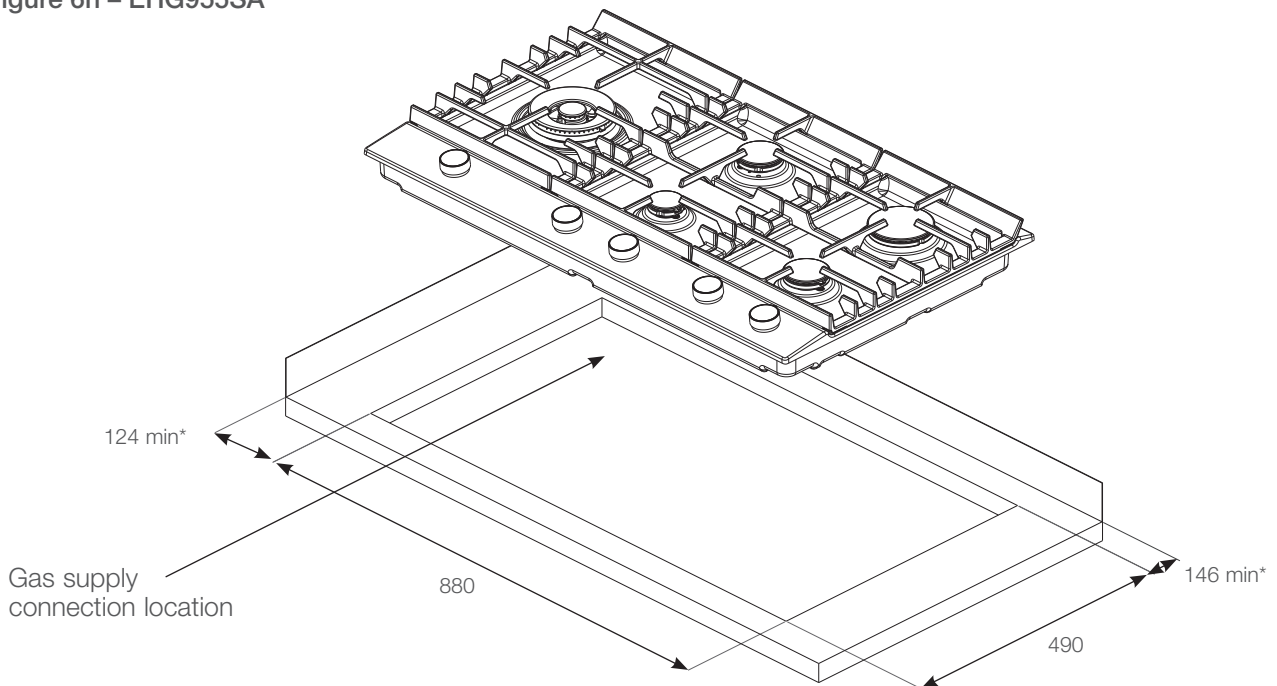

Figure 6h – EHG955SA



\* to combustible surface



## INSTALLATION PROCEDURE

1. The bench cutout should be made as per cutout dimensions in Table 2 and Figure 6.
2. **Adjacent walls, cupboards and protection for combustible materials:** Ensure that the appliance is installed in accordance with clauses 6.2.5 and 6.10.1.1 of AS/NZS 5601.1, or clauses 6.9.1 and 6.9.5 of AS/NZS 5601.2 with regard to clearances to combustible surfaces and materials, and clearances to rangehoods and exhaust fans.

To ensure clearances of 200mm from burners to vertical combustible surfaces observe the minimum distance requirements shown in Figure 7.

Clearances to combustible surfaces may be reduced if combustible surfaces are protected in accordance with clause 6.10.1.2 of AS/NZS 5601.1, or clause 6.9.2 of AS/NZS 5601.2.

3. **Barrier:** A barrier must be installed to prevent accidental contact with the cooktop base, where the base of the cooktop is accessible from below (i.e. inside a cupboard, etc.). An impression has been incorporated into the base to ensure a minimum clearance of 15mm is maintained between the base and the barrier. This barrier may be made of any non-combustible, rigid material.

Note: An alternative to the above is to purchase a barrier shield from Electrolux spare parts (P/No. ACC 072) which can be fitted directly to the underside of the product. This shield protects the user from accidentally touching certain areas of the product.

Barrier protection is not necessary if the product is installed above an underbench oven or similar appliance and/or if the cupboard construction is such that the underside of the cooktop is not accessible.

4. A FOAM SEAL has been provided and is to be applied along the perimeter of the hob.
5. Fit the pull down clamps supplied to ensure that the cooktop cannot move after installation.

### **WARNING!**

Failure to fix the cooktop to the bench could result in loosening of the gas connection through movement of the cooktop and a gas leak may result.

Four clamps and screws are supplied with 4-burner models and six clamps and screws are supplied with 5-burner models. Fit the clamps as shown in Figure 8. No clamps are needed for model EHG313BA as it is fitted with spring clips on the sides which locate on the inner edge of the bench cutout.

When benchtops are less than 33mm in thickness, it may be necessary to fit a spacer between the benchtop and each clamp to ensure clamps can be tightened sufficiently.

Figure 7a – EHG313BA

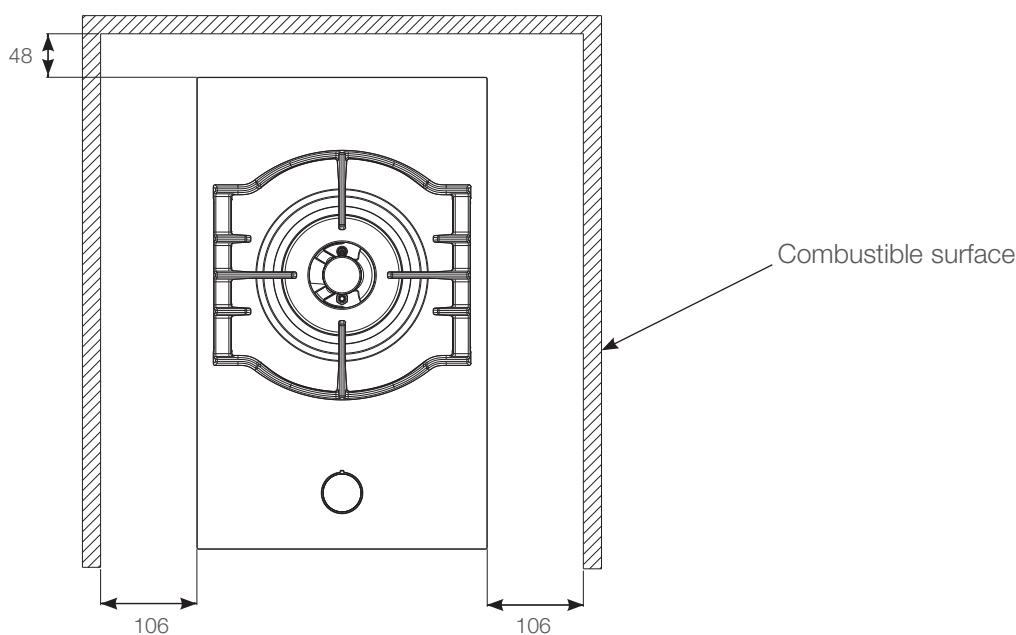

Figure 7b – EHG643BA

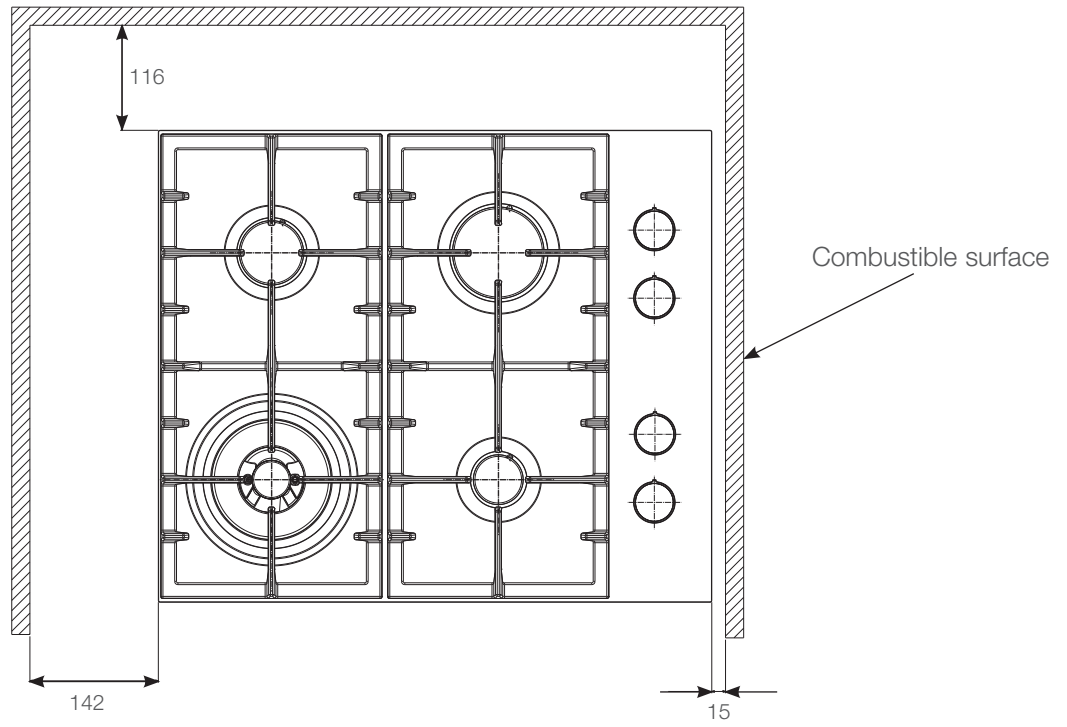

Figure 7c – EHG643SA

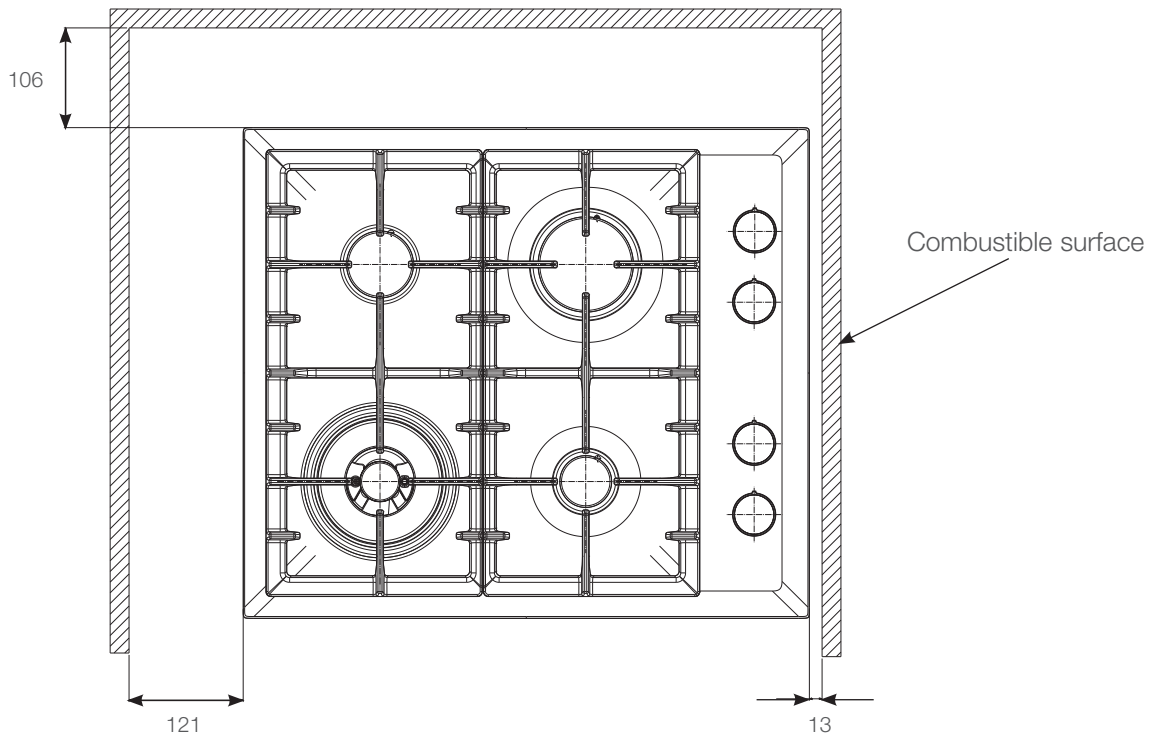

Figure 7d – EHG645SA

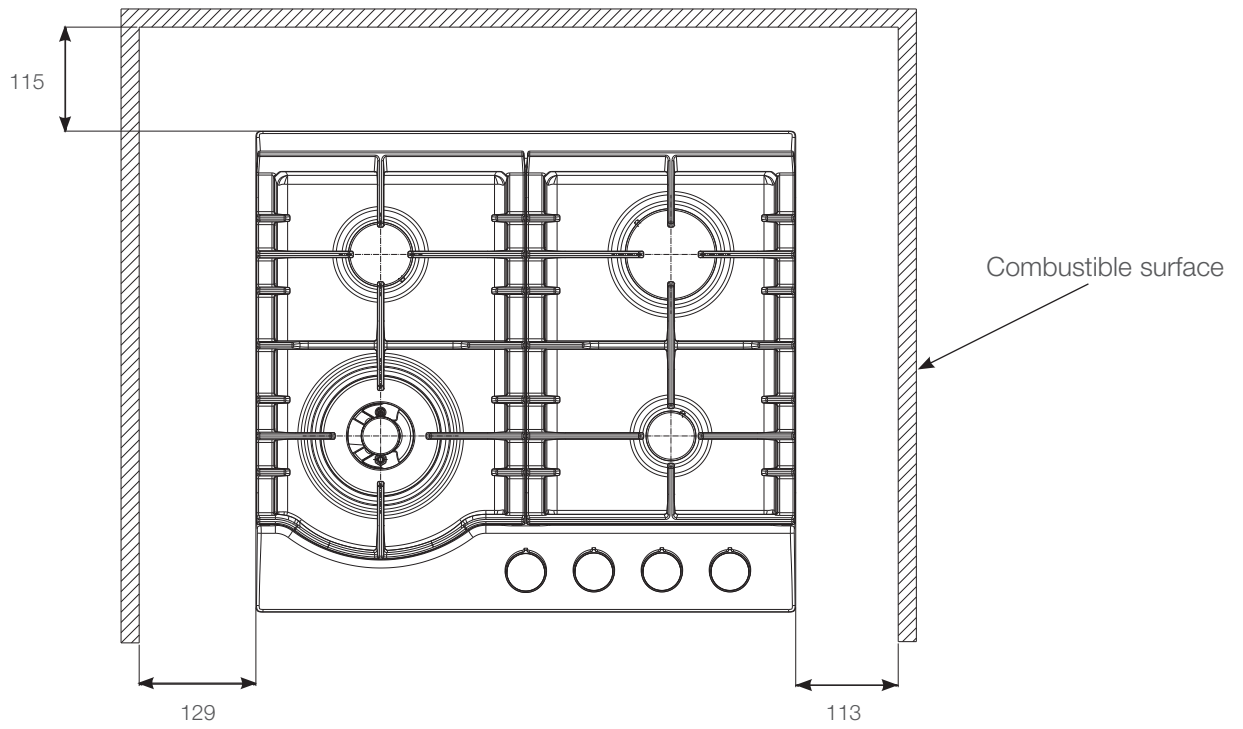

Figure 7e – EHG755SA

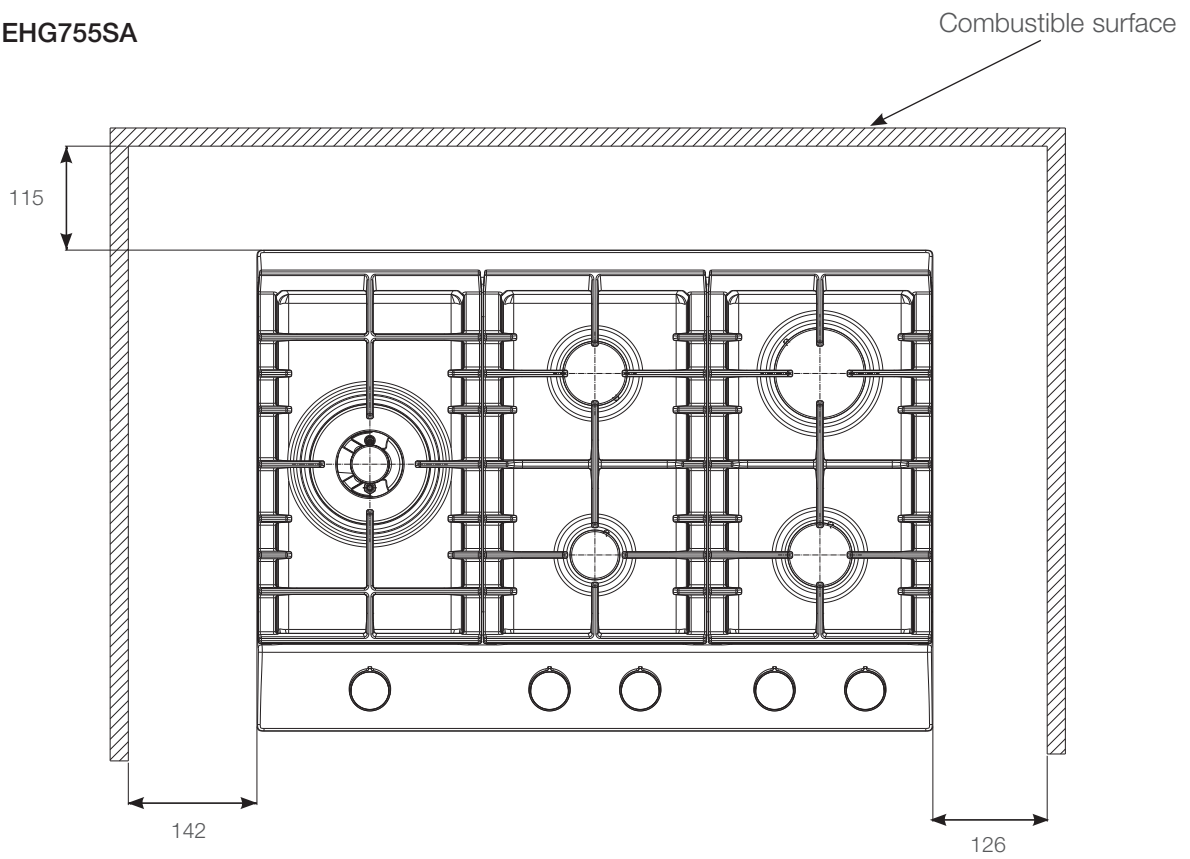

Figure 7f – EHG953SA

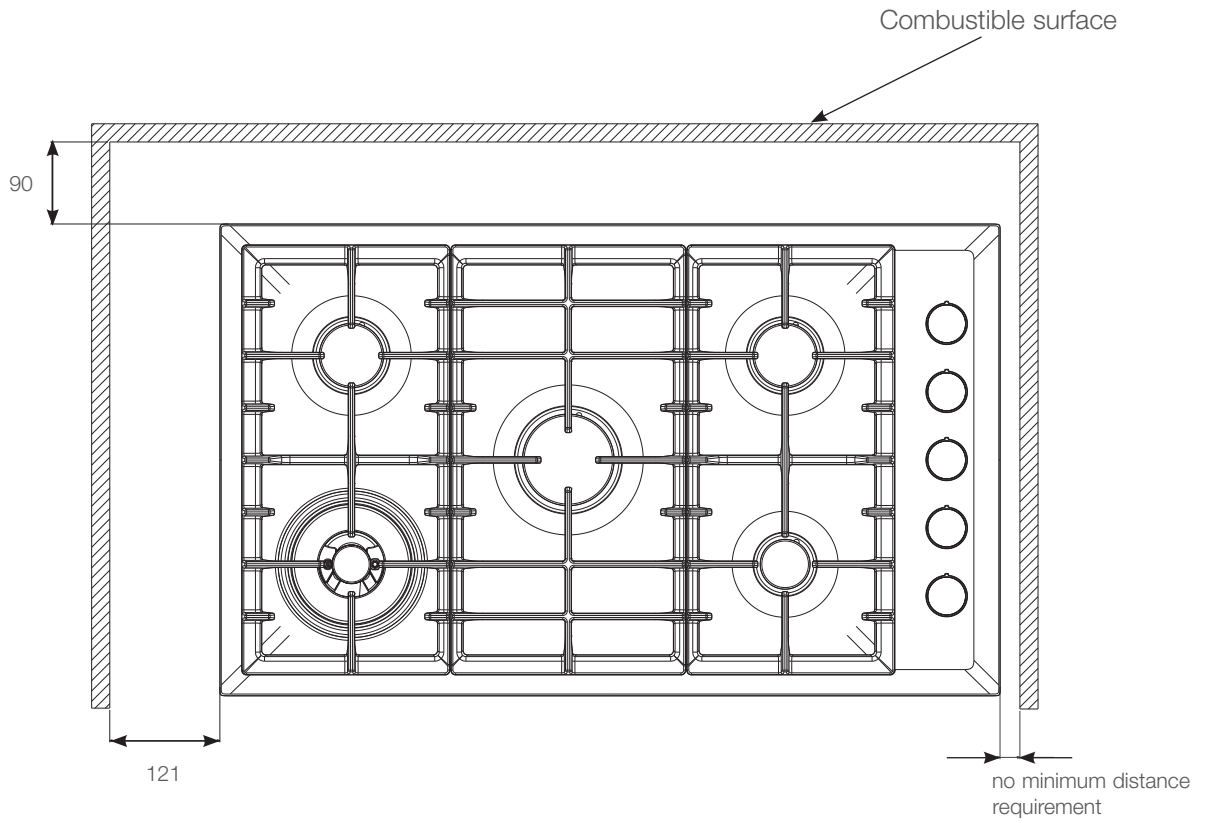

Figure 7g – EHG953BA

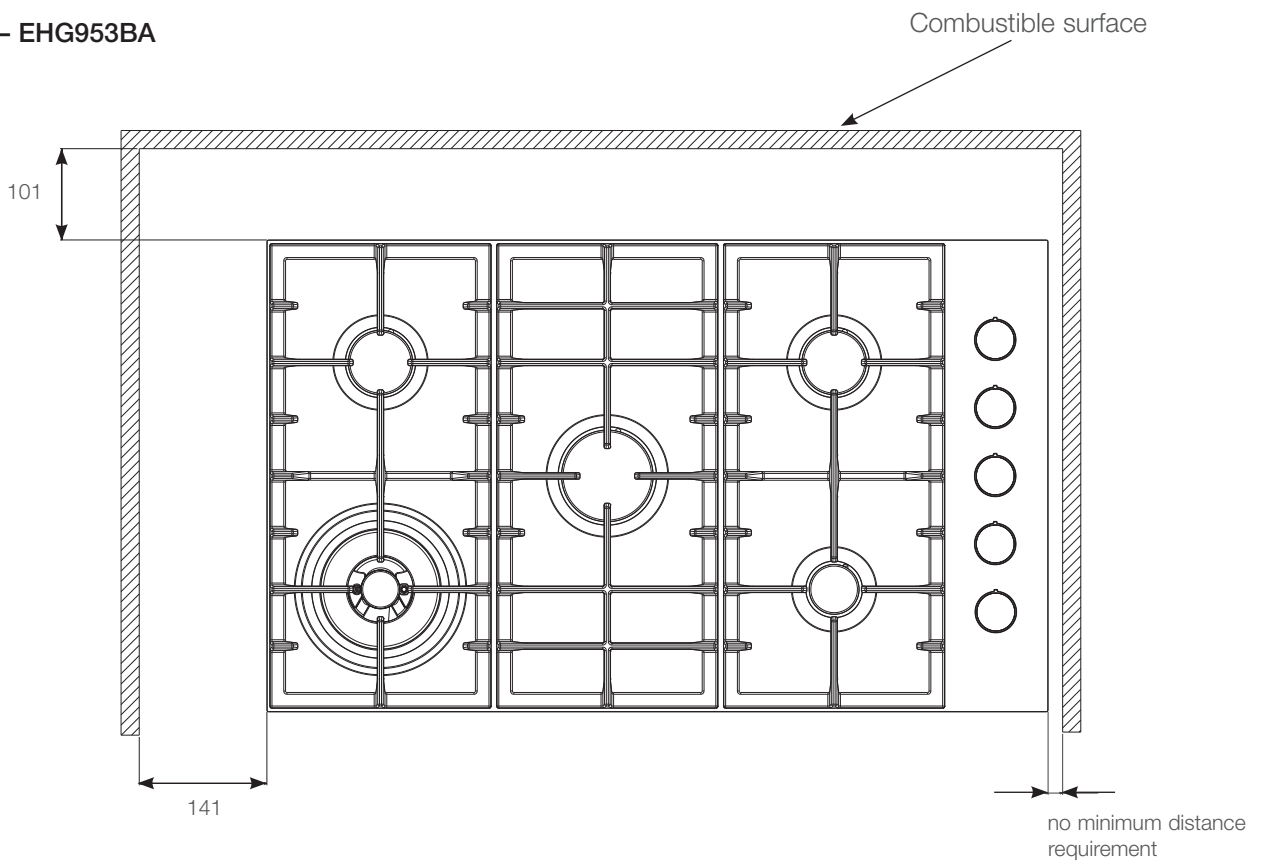

Figure 7h – EHG955SA

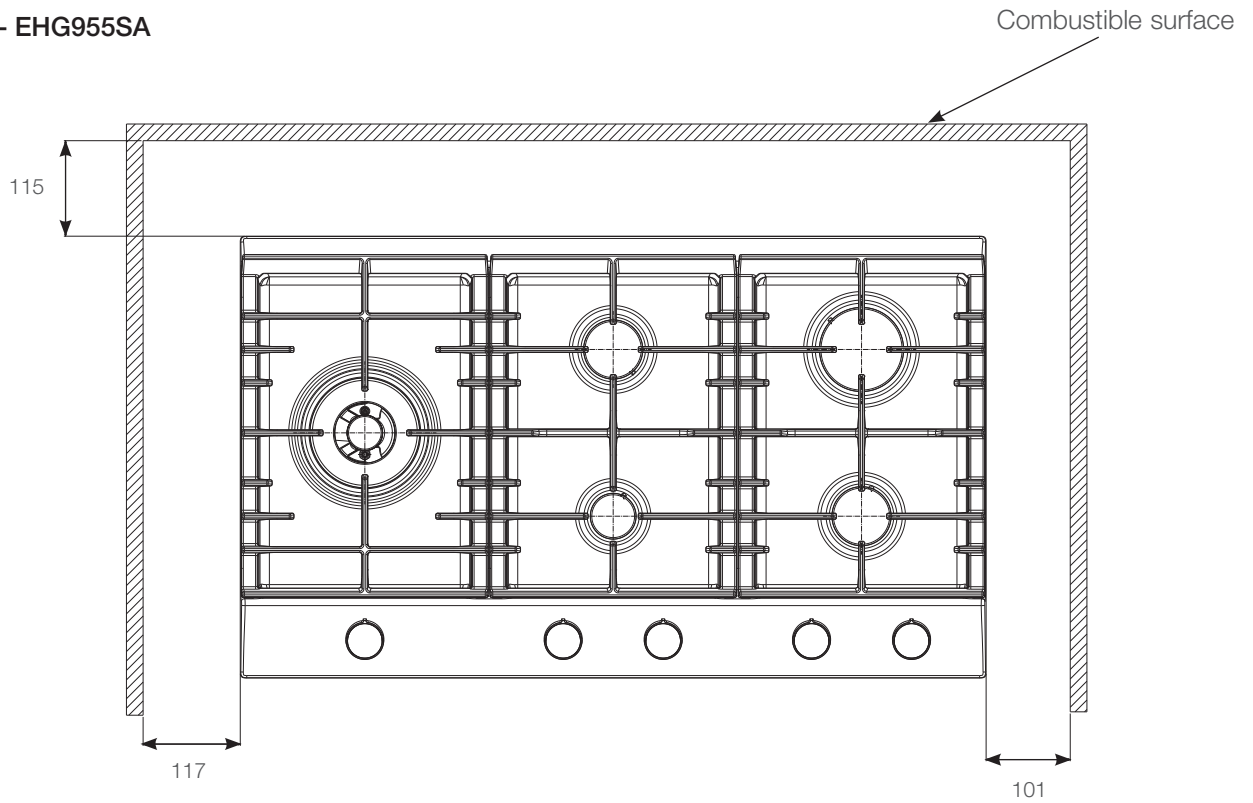
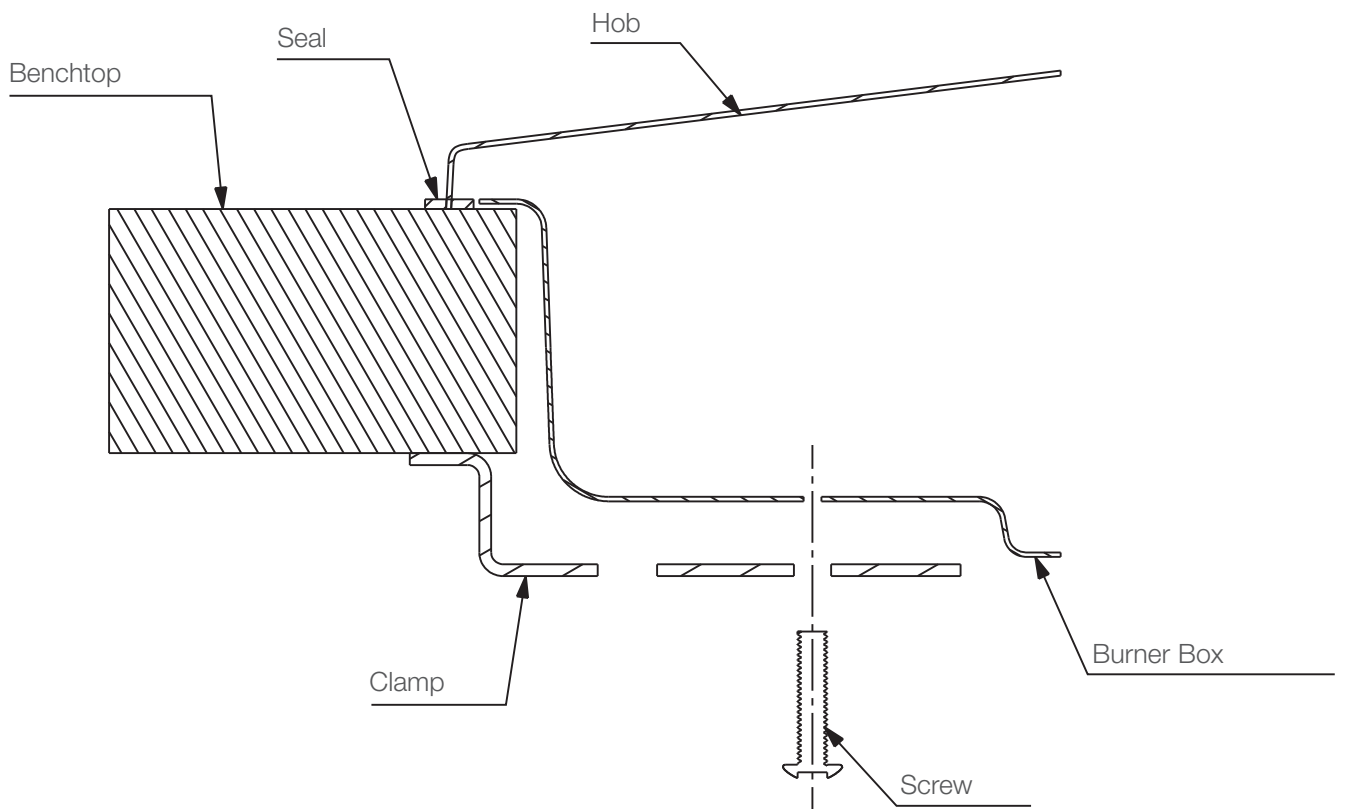

Figure 8 – Clamp fitment



## OPERATION ON N.G./S.N.G.

### GAS CONNECTION

**This appliance is supplied for use with Natural Gas. However, it can be converted for use with LPG. Refer to LP conversion on page 24 & 25.**

#### Supply pipe sizing

The total hourly gas consumption for the appliance is shown on the data label. The required supply pressure (i.e. at inlet to appliance regulator) for each gas type is shown on the data label, and given in Table 3 (page 24). Use this information in conjunction with the length of run, number of elbows, tees and bends, the available service pressure and the supply requirements of other installed appliances to determine a suitable pipe size.

For assistance in this matter refer to the appropriate section of AS/NZS 5601.1 or AS/NZS 5601.2.

An AGA certified class B or D flexible connection may be used to connect the cooktop in accordance with AS/NZS 5601.1, in particular section 5.9 and clause 6.10.1.8, or AS/NZS 5601.2, in particular section 2.11. Where a hose assembly is used and the cooktop is in the installed position, the hose assembly shall be suitable for connection to a fixed consumer piping outlet located at a point 800 – 850mm above the floor and in the region outside the width of the appliance to a distance of 250mm. The point of connection to consumer piping must be accessible with appliance installed.

### ELBOW POSITIONING

It is possible to reposition the elbow if required by loosening the locking nut and elbow by using two spanners. Re-tighten the entire assembly after the elbow has been repositioned. When fitting elbow to appliance, ensure that the sealing washer is fitted.

*NOTE TO INSTALLER: Assembly of elbow to manifold at rear of unit requires two spanners to secure locking nut and ensure leak free connection. For this reason the elbow is best secured onto cooktop manifold before installing unit into benchtop.*

#### Regulator

An appliance regulator is provided. The regulator must be positioned so that the pressure test nipple is accessible when the appliance is installed.

Connect the gas supply to the ½" B.S.P. internal thread inlet of the regulator. Refer to 'bench cutout' (Figure 6) for connection point position.

Regulators are supplied pre-adjusted and configured by the component maker for use with Natural Gas.

The appliance installer is not required to make an adjustment to obtain the correct outlet pressure setting.

An arrow on the base of the regulator indicates the direction of gas flow when the inlet and outlet of the regulator is orientated correctly. When the regulator has been fitted check for leaks from the connections with soapy water.

## OPERATION ON N.G./S.N.G.

### Assembly of Regulator

The assembly of the regulator to the cooktop manifold is achieved via the elbow union and sealing washer supplied, refer to figure 9.

The ½" parallel thread connects to the manifold, and the sealing washer is placed between the manifold end and the flat face on the elbow.

The ½" tapered thread connects to the outlet of the regulator, and is sealed on the thread using approved thread sealing tape or approved thread sealing compound.

The inlet of the regulator is a ½" parallel thread and is connected to consumer piping or hose assembly.

Regulators are supplied pre-adjusted and configured by the component maker for use with Natural Gas.

The appliance installer is not required to make an adjustment to obtain the correct outlet pressure setting.

An arrow on the base of the regulator indicates the direction of gas flow when the inlet and outlet of the regulator is orientated correctly. When the regulator has been fitted check for leaks from the connections with soapy water.

Figure 9

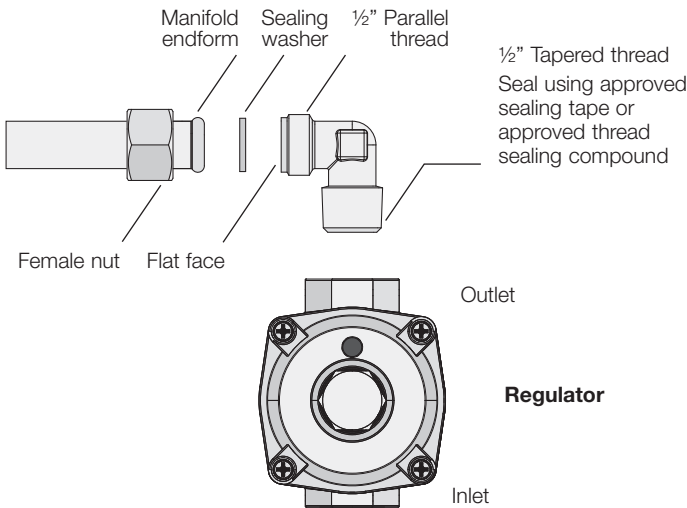

## CHECKING THE GAS SUPPLY

1. Check the manometer zero point is correct.
  2. Connect the manometer to the cooktop pressure point. This is located on the regulator.
  3. Turn on the gas supply and electricity and try to ignite the gas.
- NOTE! It will take additional time to light the gas for the first time as air needs to be purged from the pipes.*
4. With the appliance operating check the outlet pressure
    - when all burners of the appliance are operating at maximum,
    - when the smallest burner of the appliance is operating at minimum.

Under these conditions the outlet pressure should not vary from the nominal outlet pressure of 1.00kPa by more than ±0.20kPa.

If the regulator appears to not be performing satisfactorily, then check the following points:

1. If the outlet pressure is consistently too low then the inlet pressure may be too low and adjustment of an upstream regulator may be needed, or an upstream regulator or valve with insufficient flow capacity may be present in the gas supply line. If this is suspected then it may be necessary to repeat the checks whilst measuring both the inlet and outlet pressure to determine if the inlet pressure is in the range 1.13 – 5kPa.
2. Check that the regulator has been fitted to the gas supply line in the correct orientation, the arrow on the base of the body indicates the direction of gas flow.

Once these checks have been completed, if the regulator still fails to perform in a satisfactory manner it should be replaced.

### LP Conversion – Important

**This appliance is fitted with Natural Gas burner injectors.**

Please follow the procedure below if a conversion to suit LP gas is required.

The conversion kit contains appropriate LPG injectors and 1 LPG sticker.

1. Remove the hotplate burners to access the hotplate injectors. Replace the factory fitted NG injectors with the appropriate injectors, as supplied (see Table 3).

Table 3

burner type	natural gas (nominal test point pressure: 1.00kPa)		LPG (nominal test point pressure: 2.60kPa)	
	injector size (mm)	gas consumption (MJ/h)	injector size (mm)	gas consumption (MJ/h)
Small burner	1.00	5.1	0.55	4.2
Medium burner	1.35	9.0	0.70	6.5
Large burner	1.60	12.1	0.90	10.7
Wok burner	0.85 + 2 x 1.25	17.0	0.46 + 2 x 0.73	17.0

2. Unscrew the hex nut from the regulator. The hex nut, brass washer and nylon insert will disengage as an assembly.
3. Unclip the nylon insert and nut assembly by rotating the insert  $\frac{1}{4}$  turn, and pulling it free.
4. Turn over the insert and clip back into position.
5. Refit the hex nut assembly to the regulator ensuring that it is fully screwed down. The regulator is now set for connection to LP.
6. Turn on the gas supply and at each new connection check for leaks using soapy water: each hotplate valve should be turned on, one at a time, and the injector hole blanked off for several seconds.
7. The operation of the regulator can be confirmed by connecting a manometer to the pressure test point located on the side of the regulator body adjacent to the outlet.  
With the appliance operating check the outlet pressure:
  - when all burners of the appliance are operating at maximum,
  - when the smallest burner of the appliance is operating at minimum.

Under these conditions the outlet pressure should not vary from the nominal outlet pressure of 2.60kPa by more than  $\pm 0.52$ kPa.

8. If the regulator appears to not be performing satisfactorily then check the following points:
  - If the outlet pressure is consistently too low then the inlet pressure may be too low and adjustment of an upstream regulator may be needed, or an upstream regulator or valve with insufficient flow capacity may be present in the gas supply line. If this is suspected then it may be necessary to repeat the checks whilst measuring both the inlet and outlet pressure to determine if the inlet pressure is in the range 2.75 – 7.00kPa.
  - Check that the insert has been fitted correctly as per diagram figure 10. Check that the hex nut is fully screwed down.
  - Check that the regulator has been fitted to the gas supply line in the correct orientation, the arrow on the base of the body indicates the direction of gas flow.

Once these checks have been completed, if the regulator still fails to perform in a satisfactory manner it should be replaced.

9. One by one, turn the knobs to minimum and screw in the bypass screw (accessible when the knob is removed) until a small stable flame results. Turn the knob to maximum and then back to minimum to ensure that the correct minimum flame is maintained.
10. Attach the LPG sticker to the cooker, near the gas supply inlet. Cover the Natural Gas label that is factory fitted.

### Use of hose assembly

Ensure that the hose assembly is restrained from accidental contact with the flue outlet of an underbench oven or any other hot surface of an adjacent appliance.

Figure 10

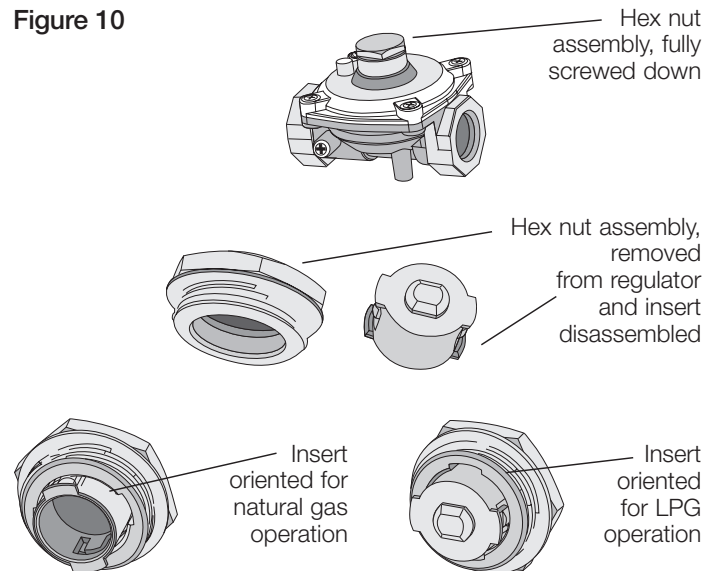

## ELECTRICAL CONNECTION (220-240 VOLTS)

The appliance is supplied with a standard 7.5 Amp service cord terminated by a 3-pin plug for connection to a standard household socket. The electrical supply is required to power the electronic ignition system.

*NOTE! It will be necessary for servicing purposes to disconnect the electrical power supply. The power point should therefore be accessible after the appliance is installed, as specified in the local wiring regulations.*

Diagram 1 is a schematic of the wiring in the appliance.

**WEIGHT** of the unit is printed on the appliance packaging label.

**Diagram 1a – All models except EHG313BA**

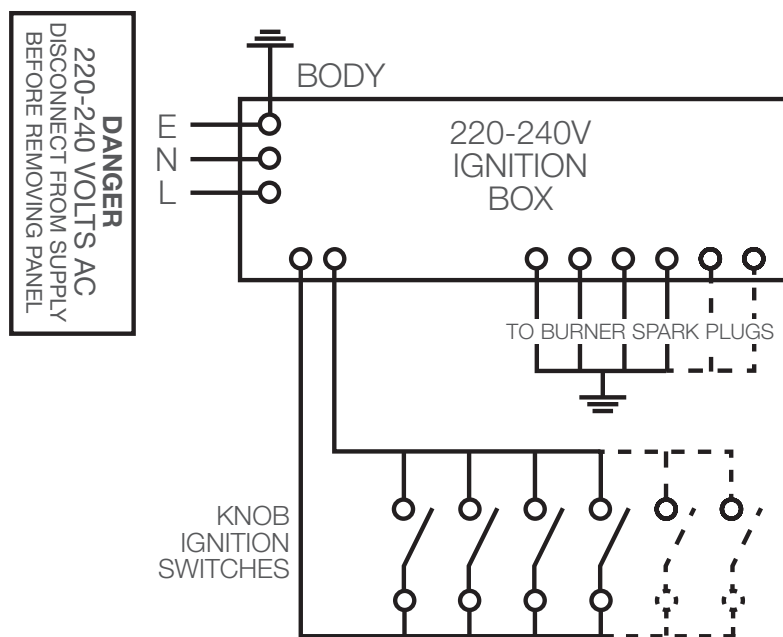

**Diagram 1b – model EHG313BA**

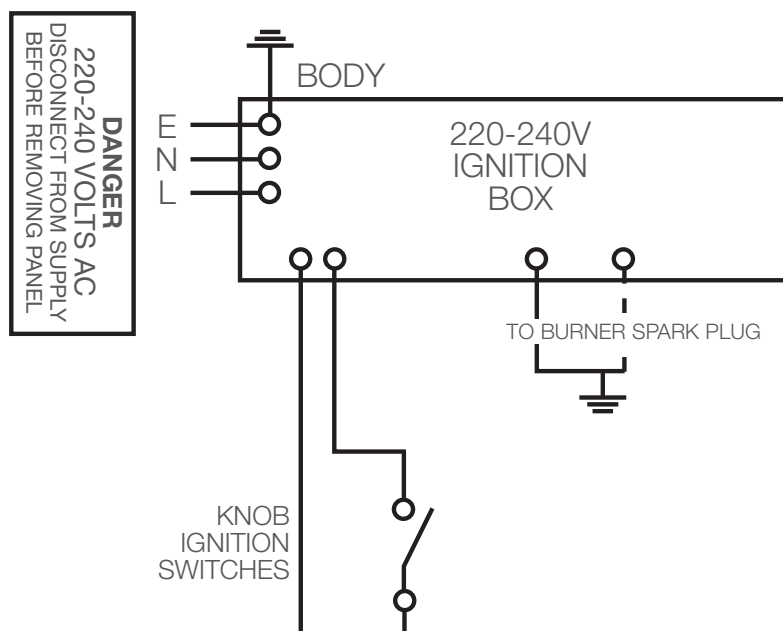

## TESTING APPLIANCE OPERATION

After installation, test the appliance and ensure that it operates correctly before handing it over to the customer. The following procedure is recommended:

1. Turn on the gas and electricity supply and attempt ignition on all burners, both separately and in combination. (For correct procedure refer to page 8 Lighting Burners). Note that additional time needs to be allowed for the initial lighting as air has to be purged from the pipes.
2. Observe the flame appearance on each burner (Figure 11). If it is much larger or much smaller than expected, the injector size and supply pressure require checking. Where a flame is unsatisfactory, refer to the Troubleshooting Guide (page 11) to correct the fault. If the Troubleshooting Guide does not solve the problem, call the Service Centre.
3. When all the foregoing is satisfactory, check the turndown (minimum or low) setting on each burner, as this may need adjustment. Valves have a bypass controlling screw, which may be accessed by removing the knob. This screw will be located on a particular area of the valve (refer Figure 12). Normally, this will have been correctly set at the factory for use on Natural Gas (NG) and should not require adjustment.



### CAUTION!

**Servicing must only be carried out by an authorised service person.**

Injector sizes required for various gas types are shown in Table 3 (page 24). The appliance test point pressure for each gas type is also shown.

For model identification after installation, an additional data plate sticker has been provided. This sticker is to be stuck onto adjacent cabinetry.

Figure 11

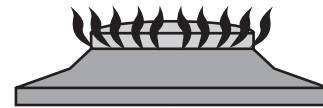

Flame size adjusted to maximum

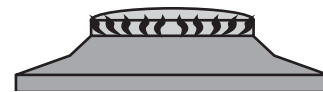

Flame size adjusted to minimum

Figure 12

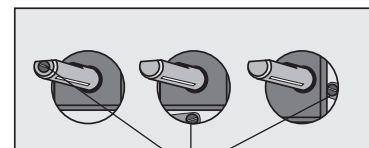

Bypass screw

### **i** IMPORTANT!

If the appliance has been converted to LPG, then the bypass screw will **HAVE** to be screwed in until a small, stable flame results.

**Please ensure the supply pressure has been checked PRIOR to any adjustment.**

4. If the appliance cannot be adjusted to perform safely inform the customer of the problem and affix an appropriate warning notice to the appliance. If the fault appears to be dangerous the appliance should be disconnected. If a minor fault exists, the customer may wish to use the appliance while awaiting service.  
If a fault cannot be fixed, please call the Service Centre.
5. The customer should be advised that, in the event of a fault, the local service organisation or the retailer from whom the appliance was purchased should be contacted.
6. When satisfied that the unit is operating correctly, turn off and instruct the customer on correct operation as outlined in this booklet. Ask the customer to operate the controls to ensure that the correct procedure is understood.



FOR SALES IN AUSTRALIA AND NEW ZEALAND  
 APPLIANCE: BUILT-IN OVEN, COOKTOP  
 AND FLOOR MOUNTED COOKER

**This document sets out the terms and conditions of the product warranties for Electrolux Appliances. It is an important document. Please keep it with your proof of purchase documents in a safe place for future reference should you require service for your Appliance.**

1. In this warranty
  - (a) 'acceptable quality' as referred to in clause 10 of this warranty has the same meaning referred to in the ACL;
  - (b) 'ACL' means Trade Practices Amendment (Australian Consumer Law) Act (No.2) 2010;
  - (c) 'Appliance' means any Electrolux product purchased by you accompanied by this document;
  - (d) 'ASC' means Electrolux' authorised service centres;
  - (e) 'Electrolux' means Electrolux Home Products Pty Ltd of 163 O'Riordan Street, Mascot, NSW 2020, ABN 51 004 762 341 in respect of Appliances purchased in Australia and Electrolux (NZ) Limited of 3-5 Niall Burgess Road, Mount Wellington, in respect of Appliances purchased in New Zealand;
  - (f) 'major failure' as referred to in clause 10 of this warranty has the same meaning referred to in the ACL and includes a situation when an Appliance cannot be repaired or it is uneconomic for Electrolux, at its discretion, to repair an Appliance during the Warranty Period;
  - (g) 'Warranty Period' means:
    - (i) where the Appliance is used for personal, domestic or household use (i.e. normal single family use) as set out in the instruction manual, the Appliance is warranted against manufacturing defects in Australia for 24 months and in New Zealand for 24 months, following the date of original purchase of the Appliance;
    - (ii) where the Appliance is used for commercial purposes (including being used to directly assist a business or where the Appliance is used in a multi-family communal or share type environment), the Appliance will then be warranted against manufacturing defects in Australia for 3 months and in New Zealand for 3 months, following the date of original purchase of the Appliance.
  - (h) 'you' means the purchaser of the Appliance not having purchased the Appliance for re-sale, and 'your' has a corresponding meaning.
2. This warranty only applies to Appliances purchased and used in Australia or New Zealand and is in addition to (and does not exclude, restrict, or modify in any way) any non-excludable statutory warranties in Australia or New Zealand.
3. During the Warranty Period Electrolux or its ASC will, at no extra charge if your Appliance is readily accessible for service, without special equipment and subject to these terms and conditions, repair or replace any parts which it considers to be defective. Electrolux or its ASC may use remanufactured parts to repair your Appliance. You agree that any replaced Appliances or parts become the property of Electrolux. This warranty does not apply to light globes, batteries, filters or similar perishable parts.
4. Parts and Appliances not supplied by Electrolux are not covered by this warranty.
5. You will bear the cost of transportation, travel and delivery of the Appliance to and from Electrolux or its ASC. If you reside outside of the service area, you will bear the cost of:
  - (a) travel of an authorised representative;
  - (b) transportation and delivery of the Appliance to and from Electrolux or its ASC,

In all instances, unless the Appliance is transported by Electrolux or an Electrolux authorised representative, the Appliance is transported at the owner's cost and risk while in transit to and from Electrolux or its ASC.
6. Proof of purchase is required before you can make a claim under this warranty.
7. You may not make a claim under this warranty unless the defect claimed is due to faulty or defective parts or workmanship. Electrolux is not liable in the following situations (which are not exhaustive):
  - (a) the Appliance is damaged by:
    - (i) accident
    - (ii) misuse or abuse, including failure to properly maintain or service
    - (iii) normal wear and tear
    - (iv) power surges, electrical storm damage or incorrect power supply
    - (v) incomplete or improper installation
    - (vi) incorrect, improper or inappropriate operation
    - (vii) insect or vermin infestation
    - (viii) failure to comply with any additional instructions supplied with the Appliance;
  - (b) the Appliance is modified without authority from Electrolux in writing;
  - (c) the Appliance's serial number or warranty seal has been removed or defaced;
  - (d) the Appliance was serviced or repaired by anyone other than Electrolux, an authorised repairer or ASC.
8. This warranty, the contract to which it relates and the relationship between you and Electrolux are governed by the law applicable where the Appliance was purchased. Where the Appliance was purchased in New Zealand for business purposes the Consumer Guarantee Act does not apply.
9. To the extent permitted by law, Electrolux excludes all warranties and liabilities (other than as contained in this document) including liability for any loss or damage whether direct or indirect arising from your purchase, use or non use of the Appliance.
10. For Appliances and services provided by Electrolux in Australia, the Appliances come with a guarantee by Electrolux that cannot be excluded under the Australian Consumer Law. You are entitled to a replacement or refund for a major failure and for compensation for any other reasonably foreseeable loss or damage. You are also entitled to have the Appliance repaired or replaced if the Appliance fails to be of acceptable quality and the failure does not amount to a major failure. The benefits to you given by this warranty are in addition to your other rights and remedies under a law in relation to the Appliances or services to which the warranty relates.
11. At all times during the Warranty Period, Electrolux shall, at its discretion, determine whether repair, replacement or refund will apply if an Appliance has a valid warranty claim applicable to it.
12. For Appliances and services provided by Electrolux in New Zealand, the Appliances come with a guarantee by Electrolux pursuant to the provisions of the Consumer Guarantees Act, the Sale of Goods Act and the Fair Trading Act.
13. To enquire about claiming under this warranty, please follow these steps:
  - (a) carefully check the operating instructions, user manual and the terms of this warranty;
  - (b) have the model and serial number of the Appliance available;
  - (c) have the proof of purchase (e.g. an invoice) available;
  - (d) telephone the numbers shown below.
14. You accept that if you make a warranty claim, Electrolux and its ASC may exchange information in relation to you to enable Electrolux to meet its obligations under this warranty.

**Important Notice**

Before calling for service, please ensure that the steps listed in point 13 above have been followed.

<p><b>FOR SERVICE</b>                  or to find the address of your nearest state service centre in Australia  <b>PLEASE CALL 13 13 49</b>                  For the cost of a local call (Australia only)</p>	<p><b>SERVICE AUSTRALIA</b>   <b>Electrolux</b>                  ELECTROLUX HOME PRODUCTS                  www.electrolux.com.au</p>	<p><b>FOR SPARE PARTS</b>                  or to find the address of your nearest state spare parts centre in Australia  <b>PLEASE CALL 13 13 50</b>                  For the cost of a local call (Australia only)</p>
<p><b>FOR SERVICE</b>                  or to find the address of your nearest authorised service centre in New Zealand  <b>FREE CALL 0800 10 66 10</b>                  (New Zealand only)</p>	<p><b>SERVICE NEW ZEALAND</b>   <b>Electrolux</b>                  ELECTROLUX HOME PRODUCTS                  www.electrolux.co.nz</p>	<p><b>FOR SPARE PARTS</b>                  or to find the address of your nearest state spare parts centre in New Zealand  <b>FREE CALL 0800 10 66 20</b>                  (New Zealand only)</p>



### **Electrolux Home Products Australia**

telephone: 1300 363 640  
fax: 1800 350 067  
email: [customercare@electrolux.com.au](mailto:customercare@electrolux.com.au)  
web: [www.electrolux.com.au](http://www.electrolux.com.au)

### **Electrolux Home Products New Zealand**

telephone: 0800 234 234  
fax: 0800 363 600  
email: [customercare@electrolux.co.nz](mailto:customercare@electrolux.co.nz)  
web: [www.electrolux.co.nz](http://www.electrolux.co.nz)

### **The Thoughtful Design Innovator.**

Do you remember the last time you opened a gift that made you say "Oh! How did you know? That's exactly what I wanted!" That's the kind of feeling that the designers at Electrolux seek to evoke in everyone who chooses or uses one of our products. We devote time, knowledge, and a great deal of thought to anticipating and creating the kind of appliances that our customers really need and want.

This kind of thoughtful care means innovating with insight. Not design for design's sake, but design for the user's sake. For us, thoughtful design means making appliances easier to use and tasks more enjoyable to perform, freeing our customers to experience that ultimate 21st century luxury, ease of mind. Our aim is to make this ease of mind more available to more people in more parts of their everyday lives, all over the world. So when we say we're thinking of you, you know we mean just that.

The "Thinking of you" promise from Electrolux goes beyond meeting the needs of today's consumers. It also means we're committed to making appliances safe for the environment—now and for future generations.

### **Electrolux. Thinking of you.**

Share more of our thinking at [www.electrolux.com.au](http://www.electrolux.com.au) or [www.electrolux.co.nz](http://www.electrolux.co.nz)

**P/No. 305 6209 00**

© 2013 Electrolux Home Products Pty Ltd.  
ABN 51 004 762 341

EMAN\_GAS\_HOBS\_UM\_Jul13