



EN ■ Hand Mixer

READ CAREFULLY AND STORE FOR FUTURE USE.

- This appliance may be used by persons with physical or mental impairments or by inexperienced persons, if they are properly supervised or have been informed about how to use the appliance in a safe manner and understand the potential dangers.
- Children must not use this appliance or play with it. Keep this appliance and the power cord out of reach of children.
- The appliance is designed for household use only. It is not intended for use in locations such as:
 - staff kitchens in stores, offices and other workplaces;
 - hotel or motel rooms and other living areas;
 - agricultural farms;
 - bed and breakfast establishments.
- This appliance is designed for mixing, kneading and whipping food. Do not use it for any other purposes than those intended.



Warning:

Incorrect use may lead to injuries.

- Do not use the appliance in an industrial environment or outdoors.
- Before connecting this appliance to a power socket, make sure the rated voltage stated on its rating label corresponds to the voltage in your power socket.
- Do not place the appliance on an electric or gas stove or in its vicinity, on the edge of a table or on an unstable surface. Only place the appliance on an even, dry and stable surface.
- Only use the appliance with the original accessories that came with it.
- Before first use, it is necessary to thoroughly wash the removable attachments using warm water and kitchen detergent, then rinse then with drinking water and wipe thoroughly until dry using a fine wiping cloth.
- Before turning on the appliance, always make sure that the removable attachments are properly attached to the motor unit. Never combine various types of attachments.
- Do not use the appliance if you have wet hands.
- Do not cover the appliance's vents.
- Do not run the appliance without load. Incorrect use of the appliance may negatively affect its lifetime.
- Only start the appliance after submerging the balloon whisk, beaters or kneading hooks in the container with the ingredients. To prevent food from splashing out, keep the attachments submerged in the container with the ingredients while the appliance is running.
- Avoid coming into contact with the rotating parts of the appliance. While mixing, do not place hands, forks or any other utensils into the bowl with the ingredients, and keep hair, clothing, etc. at a sufficient distance from the rotating parts of the appliance. If a fork or another utensil falls into the container while mixing, immediately turn off the appliance.
- Be especially careful when handling hot foods and liquids. Hot steam or splashing hot foods and liquids may cause scalding. For reasons of increased safety, it is recommended to allow hot liquids and foods to cool down before mixing them. Never mix hot foods and liquids directly in a pot located on a turned on hotplate.

- If you have just processed hot foods, the removable attachments may be hot after they are used.
- If ingredients stick to the rotating attachments or the inside walls of the container, turn the appliance off and unplug it from the power supply. Make sure that the rotating parts have stopped rotating and remove the attachments. Clean the walls of the container and accessories using a plastic spatula. Then reassemble the appliance, connect it to a power socket, and then you may continue blending.
- Do not leave the appliance in continuous operation for longer than 10 minutes. Before turning it on again, allow it to cool down.
- Always turn off the appliance and disconnect it from the power socket if you will not be using it and if you will be leaving it without supervision, before changing accessories, before assembly, disassembly, cleaning and before moving it. Before disassembling or changing accessories that move during operation, make sure that the rotating parts have stopped.
- Keep the appliance clean. Clean it according to the instructions in chapter Cleaning and maintenance. Do not submerge the motor unit and its power cord in water or any other liquid, or wash these parts under running water. The removable attachments are intended for short term contact with food (including beverages), i.e. max. 4 hours. To prevent damaging their surface, do not leave them submerged, for example in water for extended periods of time.
- Ensure that the power plug contacts do not come into contact with moisture. Do not place heavy items on the power cord. Make sure that the power cord does not hang over the edge of a table or that it is not touching a hot surface.
- Disconnect the appliance from the power socket by pulling on the plug, never pulling on the power cord. Otherwise, this could damage the power cord or the socket.
- If the power cord is damaged, it must be replaced by an authorised service centre or by another similarly qualified person, this will prevent the creation of a dangerous situation. It is forbidden to use the appliance if it has a damaged power cord.
- Do not use the appliance when it is not functioning properly or showing any signs of damage. In order to prevent a hazardous situation arising, do not repair the appliance yourself or modify it in any way. Have all repairs performed at an authorised service centre. By tampering with the appliance, you risk voiding your legal rights arising from unsatisfactory performance or quality warranty.

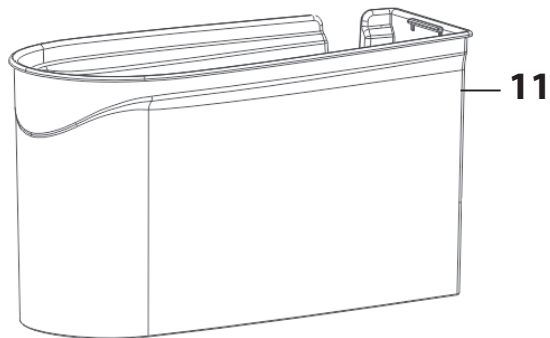
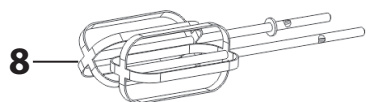
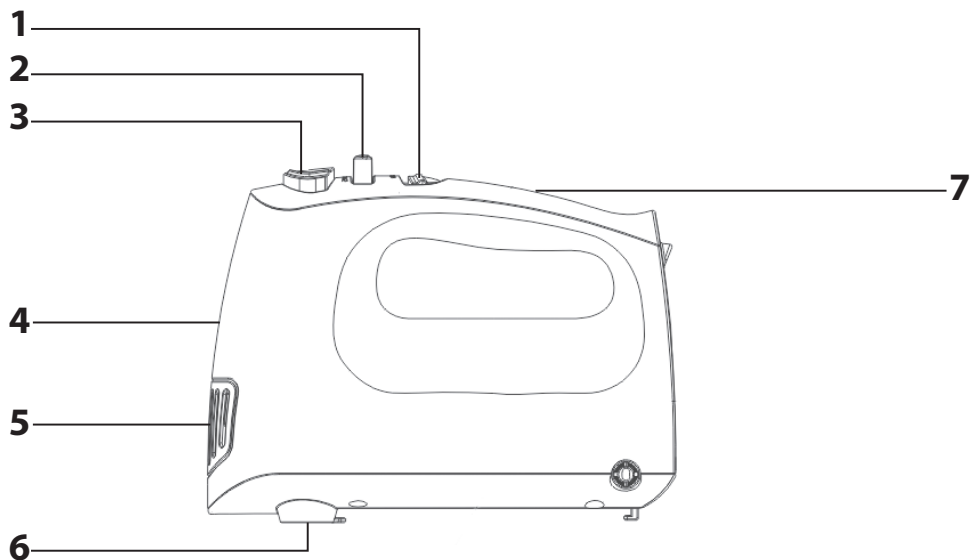
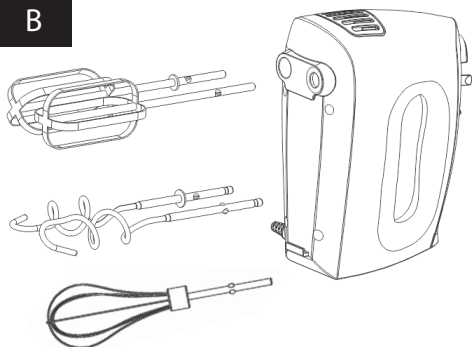
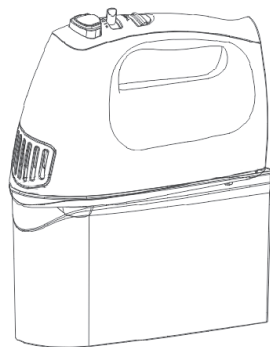
A**B****C**

EN Hand Mixer

User's manual

- Prior to using this appliance, please read the user's manual thoroughly, even in cases, when one has already familiarised themselves with previous use of similar types of appliances. Only use the appliance in the manner described in this user's manual. Keep this user's manual in a safe place where it can be easily retrieved for future use.
- We recommend saving the original cardboard box, packaging material, purchase receipt and responsibility statement of the vendor or warranty card for at least the duration of the legal liability for unsatisfactory performance or quality. In the event of transportation, we recommend that you pack the appliance in the original box from the manufacturer.

DESCRIPTION OF THE APPLIANCE

A1 Turbo pulse switch for setting maximum speed	A6 Holes for attaching removable attachments
A2 Power and speed setting switch	A7 Handle
A3 Button for releasing removable attachments	A8 Set of beaters
A4 Motor unit	A9 Set of kneading hooks
A5 Vents	A10 Balloon whisk
	A11 Removable attachment storage box

BEFORE FIRST USE

1. Remove all packaging materials, including promotional tags and labels from the appliance and its accessories.
2. Use one hand to hold the storage box **A11** and the other to grasp the motor unit **A4** by the handle **A7** and take it off the box **A11**. Take the removable attachments out of the box **A11**.
3. Thoroughly wash the storage box **A11** and the removable attachments **A8**, **A9**, and **A10** that are intended to come into contact with food using warm water and a neutral kitchen detergent. Then rinse everything with clean water and allow it to dry naturally or dry it out thoroughly using a wiping cloth. No part of this appliance is suitable for washing in a dishwasher.



Attention:

Do not rinse the motor unit **A4** and its power cord under water or submerge it in water.

INTENDED USE OF THE ATTACHMENTS

Attachment type	Purpose of use
Beaters A8	Mixing and whipping – batter dough, mashed potatoes, whipped cream, foam from egg whites, creams, etc.
Kneading hooks A9	Kneading – bread dough, fresh dough for pasta, pizza or biscuits, puff dough, etc.
Balloon whisk A10	Whisking – whipped cream, foam from egg whites, foam creams, etc. Do not use it for mixing or kneading dough.

ASSEMBLING AND DISASSEMBLING THE APPLIANCE

- Before you start assembling or disassembling the appliance, check that the switch **A2** is set to position 0 (off) and that the motor unit **A4** is disconnected from the power socket and that the rotating parts have come to a complete stop.
- Select attachment type **A8**, **A9** or **A10**, that you wish to use and fasten it into the holes **A6** underneath the motor unit **A4** (see fig. B). The correct procedure must be followed when inserting the attachments into the holes **A6**. Otherwise, the attachments could come loose during operation. Insert the beater or hook with the ring into the left hole and push it towards the motor unit **A4** until it is secured in place. In the same way, attach the other attachment of the same type into the right hole. Insert the balloon whisk **A10** only into the right hole.



Attention:

Never combine various types of accessories.

- To remove the attachments, put the appliance into a vertical position and stand it on an even surface. Press button **A3**. This will release the attachments from the holes underneath the motor unit **A4**, and then it is easy to take them out. Do not use force to remove the attachments.



Attention:

Button **A3** cannot be pressed unless switch **A2** is set to position 0 (turned off).

OPERATING THE APPLIANCE

1. Place the food and liquids that you wish to process into a sufficiently large container.
2. Assemble the appliance according to the instructions in the chapter Assembling and disassembling the appliance. Unwind the full length of the power cord and connect the appliance to a power socket.
3. Submerge the attachments into the container with the ingredients, then start the appliance by setting switch **A2** to the required speed level in the range from 1 to 5. To initially stir in the ingredients, we recommend that you first set a lower speed and then adjust it as required. For kneading dough, use only speed 1. To prevent the ingredients from splashing out of the container during operation, keep the attachments submerged in the container.



Attention:

The maximum continuous operating time of the appliance is 10 minutes. Before using it again, allow the appliance to cool down for 15 minutes. When kneading heavy, thick doughs, do not leave the appliance running for more than 5 minutes.

4. Hold down the pulse button **A1** to run the appliance at maximum speed. To prevent the appliance from overheating, do not use this button for longer than 30 seconds.
5. After you have finished using the appliance, set switch **A2** to position 0 (off) and disconnect the power cord from the power socket. Make sure that the rotating parts have stopped rotating. Put the appliance into a vertical position and stand it on an even surface. Remove all the used attachments and then clean all the used parts according to the instructions in chapter Cleaning and maintenance.

QUICK GUIDE TO PROCESSING INGREDIENTS

Beaters **A8**

Type of ingredients or meals	Amount	Processing time	Recommended speed setting
Creams	approx. 600 g	approx. 5 minutes	level 4
Mashed potatoes	max. 750 g	max. 3.5 minutes	level 3-4
Whipped cream	max. 500 g	max. 5 minutes	level 5
Egg whites	max. 5 egg whites	approx. 3 minutes	level 5
Batter	approx. 600 g	approx. 5 minutes	level 3-4

Kneading hooks **A9**

Type of ingredients or meals	Amount	Processing time	Speed setting
Bread dough	max. 500 g of flour	2x 5 minutes	level 1
Dough for fresh pasta	max. 300 g of flour	5 minutes	level 1

Balloon whisk **A10**

Type of ingredients or meals	Amount	Processing time	Recommended speed setting
Whipped cream	max. 500 g	max. 5 minutes	level 5
Egg whites	max. 5 egg whites	approx. 3 minutes	level 5
Whipped foam	approx. 600 g	approx. 1 minute	level 1



Note:

The above processing times are only a reference. When whipping egg whites, the container and attachments must be perfectly clean and dry. Even a small amount of fat may cause the egg whites not to be whipped to the desired snowy consistency. Whipping cream should be cooled to a temperature of 6°C prior to being whipped. Prior to processing them, allow the ingredients used for making various doughs to rest at room temperature.

CLEANING AND MAINTENANCE

- Before cleaning, make sure that the appliance is turned off, disconnected from the power socket and that the rotating parts are not moving.
- Thoroughly wash the removed attachments using warm water and neutral kitchen detergent. Then rinse them with clean water and dry thoroughly with a fine wiping cloth. The removable attachments are intended for short term contact with food (including beverages), i.e. max. 4 hours. To prevent damaging their surface, do not leave them submerged, for example in water for extended periods of time.
- In the event that the storage box **A11** is soiled, wash it in warm water using a neutral kitchen detergent. Then rinse it with clean water and dry thoroughly with a fine wiping cloth.
- To clean the outer surface of the motor unit **A4**, use a cloth lightly dipped in a weak detergent solution. After applying the detergent solution, wipe the surface with a cloth lightly dampened in clean water and then wipe dry.
- No part of this appliance is suitable for washing in a dishwasher. Never submerge the motor unit **A4** or the power cord in water or in any other liquid.
- Do not use solvents, cleaning products with an abrasive effect, etc. for cleaning the appliance. Otherwise, the surface coat of the appliance may be damaged.

STORAGE

- When not using the appliance, store the attachments in the storage box **A11**. Store the beaters **A8** in the storage box **A11** with the opposite ends facing each other, and store the kneading hooks **A9** in the same way.
- Tilt the motor unit **A4** so that its front part slides in from underneath into the front part of the storage box **A11** and then push the rear part of the motor unit **A4** towards the storage box **A11** until both parts connect firmly to each other (see fig. C). When lifting the motor unit **A4** by the handle **A7**, the storage box **A11** should remain attached to the motor unit **A4**. Finally, place the appliance in a clean, dry place out of children's reach.

TECHNICAL SPECIFICATIONS

Rated voltage range.....	220–240 V
Rated frequency.....	50/60 Hz
Rated power input.....	400 W
Electrical shock protection class.....	II
Noise level.....	85 dB(A)

The declared noise emission level of the appliance is 85 dB(A), which represents a level A of acoustic power with respect to a reference acoustic power of 1 pW.

Explanation of technical terminology

Safety class for electrical shock protection:

Class II – Electrical shock protection is provided by double or heavy-duty insulation.

Changes to text and technical parameters are reserved.

INSTRUCTIONS AND INFORMATION REGARDING THE DISPOSAL OF USED PACKAGING MATERIALS

Dispose of used packaging material at a site designated for waste in your municipality.

DISPOSAL OF USED ELECTRICAL AND ELECTRONIC EQUIPMENT



This symbol on products or original documents means that used electric or electronic products must not be added to ordinary municipal waste. For proper disposal, renewal and recycling hand over these appliances to determined collection points. Alternatively, in some European Union states or other European countries you may return your appliances to the local retailer when buying an equivalent new appliance.

Correct disposal of this product helps save valuable natural resources and prevents potential negative effects on the environment and human health, which could result from improper waste disposal. Ask your local authorities or collection facility for more details.

In accordance with national regulations penalties may be imposed for the incorrect disposal of this type of waste.

For business entities in European Union states

If you want to dispose of electric or electronic appliances, ask your retailer or supplier for the necessary information.

Disposal in other countries outside the European Union.

This symbol is valid in the European Union. If you wish to dispose of this product, request the necessary information about the correct disposal method from the local council or from your retailer.



This product meets all the basic requirements of EU directives related to it.