

Electric Hot Food Table with Sealed-in Wells (SHT Series)

OPERATIONS MANUAL & INSTRUCTIONS

Retain this manual for future reference.

CAUTION

INSPECT CONTENTS IMMEDIATELY AND FILE CLAIM WITH DELIVERING CARRIER FOR ANY DAMAGE. **SAVE YOUR BOX AND ALL PACKING MATERIALS.** YOU ARE RESPONSIBLE FOR DAMAGE TO YOUR UNIT IF RETURNED IMPROPERLY PACKED.

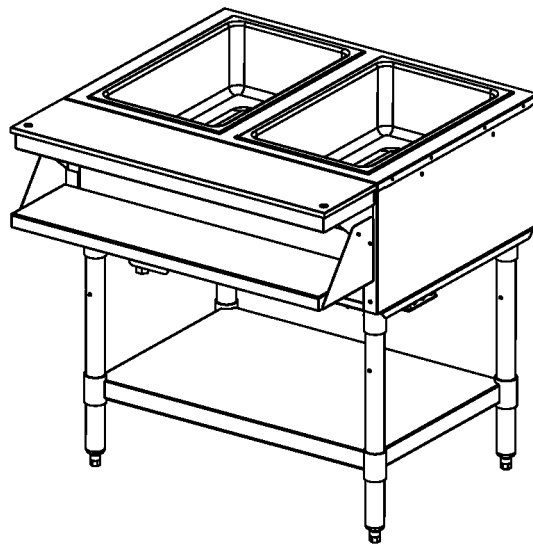

Contact the factory, the factory representative or Eagle's authorized service center in your area.

(continued on next page) 

EG9812 revised 08/22



- 100 Industrial Boulevard, Clayton, Delaware 19938-8903 U.S.A.
- Phone: 302/653-3000 • 800/441-8440
- Fax: 302/653-2065 • www.eaglegrp.com

Electric Hot Food Table with Sealed-in Wells (SHT Series)

SAFETY TIPS AND WARNINGS

These models are designed, built and sold for commercial use. However, if these models are positioned so the general public can use the equipment, MAKE SURE THAT ALL CAUTIONS, WARNINGS AND OPERATING INSTRUCTIONS ARE CLEARLY POSTED NEAR EACH UNIT so that anyone using the equipment will use it correctly and not injure themselves or harm the equipment.

WARNINGS



READ THE INSTALLATION, OPERATING AND MAINTENANCE INSTRUCTIONS THOROUGHLY BEFORE INSTALLING OR SERVICING THIS EQUIPMENT. Improper installation, adjustment, alteration, service or maintenance can cause property damage, injury or death.



Check the data plate on this unit before installation. Connect the unit only to the voltage and frequency listed on the data plate. Connect only to 1 or 3 phase as listed on the data plate.



Disconnect electrical power supply and place a tag at disconnect switch, indicating that you are working on the circuit.



Do not open any panels that require the use of tools.



Do not store or use gasoline or other flammable vapors or liquids in the vicinity of this or any other appliance.



This unit is not intended to hold potentially hazardous foods, such as uncooked meats.



SHOCK HAZARD!



IMPROPER GROUNDING COULD RESULT IN ELECTRICAL SHOCK. This appliance is equipped with a three-prong (grounded) plug for your protection against electrical shock hazard and should be plugged directly into a properly grounded three-prong receptacle. DO NOT CUT OR REMOVE THE GROUNDING PRONG FROM THIS PLUG.

CANADIAN INSTALLATION MUST COMPLY WITH CSA-STANDARD C.22.2 No. M1982 General Requirements - Canadian Electrical Code, Part II, 109-M1981 - Commercial Cooking Appliances.

NOTICE: Local Codes regarding installation vary greatly from one area to another. The National Fire Protection Association, Inc., states in its NFPA 96 latest edition that local codes are “authority having jurisdiction” when it comes to requirements for installation of equipment. Therefore, INSTALLATIONS SHOULD COMPLY WITH ALL LOCAL CODES.

(continued on next page) 

Electric Hot Food Table with Sealed-in Wells (SHT Series)

OPERATIONS MANUAL & INSTRUCTIONS

The Hot Food Table will work most efficiently when used with hot water in the pan liner. The hot water will give a better distribution of heat and help keep food from drying out. It is not designed for cooking foods but merely to keep cooked foods at desired temperatures for serving.

During initial operation, a little smoke or odor may be detected. This will occur when the coating on the heating element burns off. This should stop after a half hour of operation.

This unit is equipped with a variable control for different heat selections.

WET OPERATION WITH COVER

(IF USING AUTOFILL®, PLEASE SEE BACK PAGE)

1. Ensure unit is level in both directions, adjust feet in or out as necessary.
2. Ensure drain valve is in the closed position.
3. Pour hot water (minimum of 185°F [85°C]) into first well. Water will flow through manifold and fill all the wells, stop when a depth of about 1" has filled all the wells. This may take a few minutes to level out between all wells.
4. Set dial to highest position for 45 minutes with well covered to preheat unit, place food pan with precooked food (minimum 150°) into well and cover food pans with lids. (Note: Indicator light is the set point for the control knob.)
5. Adjust to desired setting for proper food temperature. This will vary with the type of food, type of pans and individual serving temperature. NSF requires a minimum temperature of 150°F in food product.
6. To increase temperature turn knob toward highest setting, to decrease turn knob toward lowest setting.
7. Change water, clean well and wipe dry after every 24 hours of operation. Water may have to be added to pan during operation depending on operating time and temperature setting.
8. Food pans must be covered to maintain temperature when food is not being served and to prevent food from drying out.

The above instructions are starting suggestions only and may be changed to suit your individual needs. With so many different applications for this item it is impossible to have standard settings to suit all situations.

NOTE: If unit is used dry, the bottom of the well will take on a brown colored appearance where the heater is located. The discoloration will not come off with normal cleaning procedures, but in no way will it affect the operation of the unit.

CAUTION:

1. This equipment is designed and sold for commercial use only by personnel trained and experienced in its operation, and is not sold for consumer use in and around the home, nor for use directly by the general public in food service locations.
2. Do not immerse unit in water.
3. All repairs should be performed by an authorized service center.
4. Unit should be turned off when not in use. It is recommended that unit be disconnected from power supply by removing plug from receptacle or shutting off power disconnect supply to the unit.
5. Unit must be operated with legs provided to prevent overheating and damage to surface below or cord.

(continued on next page) 

Electric Hot Food Table with Sealed-in Wells (SHT Series)

OPERATIONS MANUAL & INSTRUCTIONS

MAINTENANCE

1. The inside of the water compartment and outer shell should be washed daily, using a clean cloth or sponge and mild detergent.

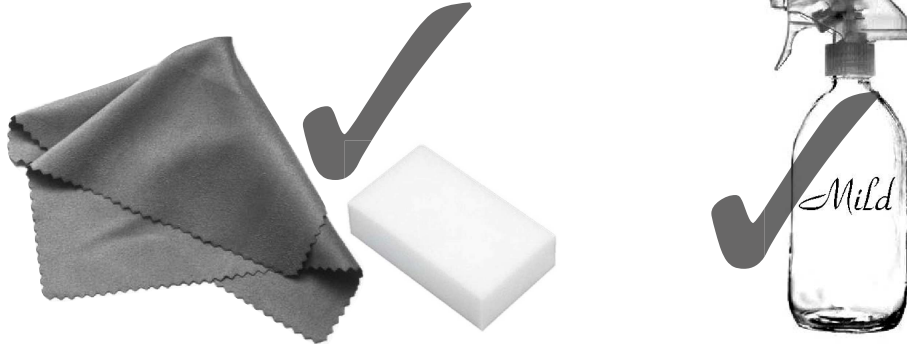

2. Use a plastic scouring pad to remove any hardened food particles or mineral deposits. DO NOT use chemicals, steel wool, or scrapers to clean the unit.

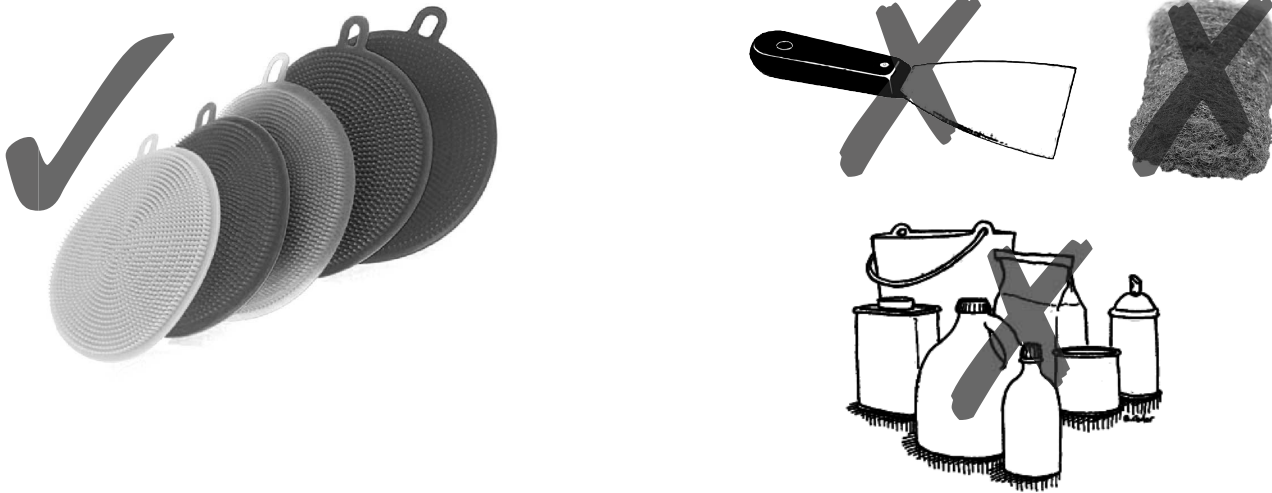

(continued on next page) 

Electric Hot Food Table with Sealed-in Wells (SHT Series)

ASSEMBLY INSTRUCTIONS

For Stationary Units, install undershelf and legs.

If your unit is a Mobile Unit, skip this page and refer to page 6.

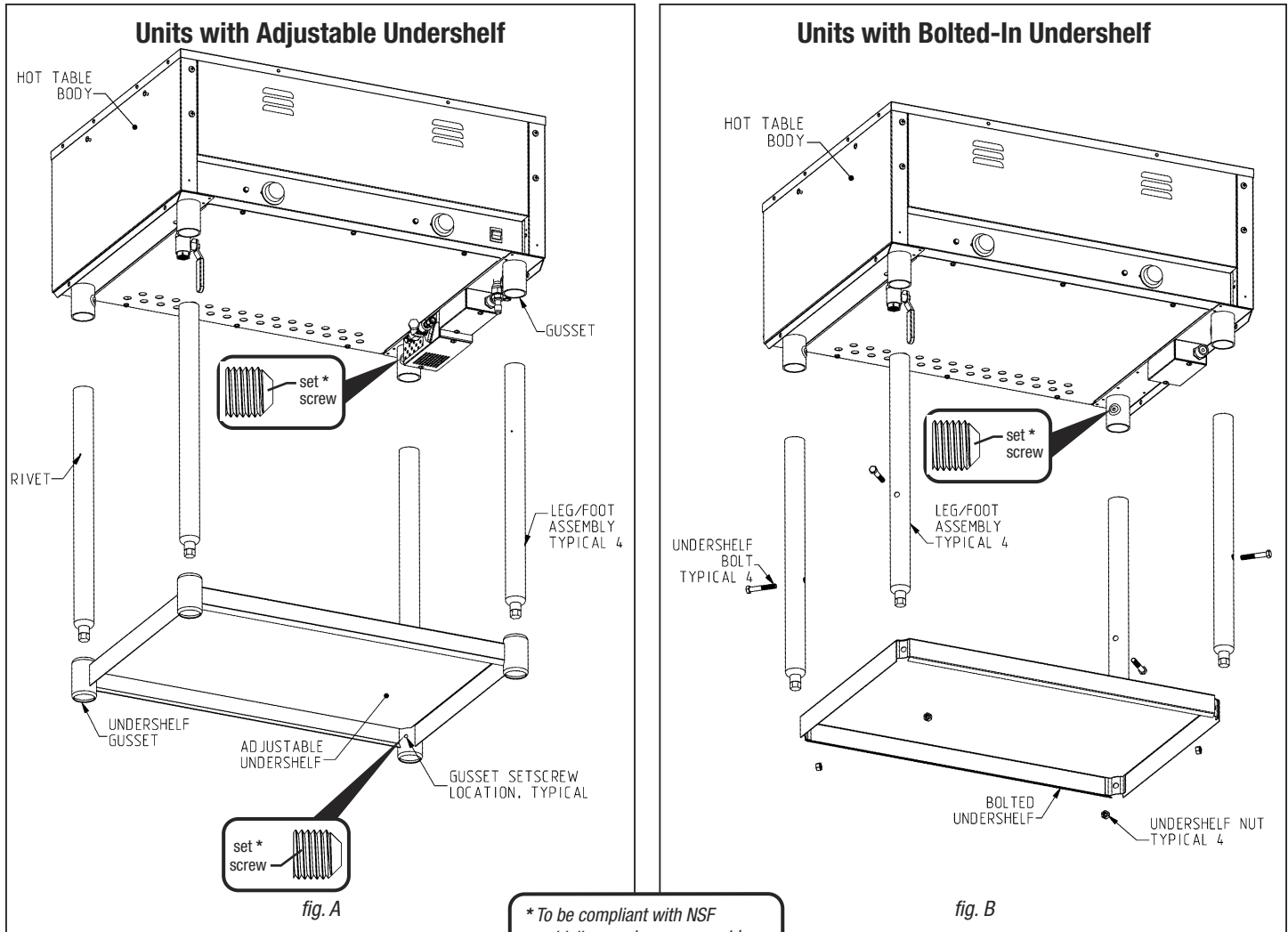

* To be compliant with NSF guidelines, set screws must be filled with NSF-approved sealant.

1. After removing crate above shipping pallet, gently lay the unit onto its back.

Caution: Use cardboard or other material to prevent scratching.

2. Install legs into undershelf gussets with feet to underside of shelf.

3. FOR UNITS WITH ADJUSTABLE UNDERSHELF (fig. A):

- Loosely tighten set screws on undershelf. Work legs into gussets on underside of unit and tighten set screw securely.
- Adjust undershelf to desired height and tighten set screws securely.
- Repeat on remaining legs and undershelf corners.

FOR UNITS WITH BOLTED-IN UNDERSHELF (fig. B):

- On each leg, run undershelf bolt through hole in leg and into undershelf corner.
- Secure with undershelf nut. Repeat on remaining legs and undershelf corners.

4. Place table upright.

(continued on next page)

Electric Hot Food Table with Sealed-in Wells (SHT Series)

ASSEMBLY INSTRUCTIONS

For Mobile Units, install undershelf and casters.

If your unit is a Stationary Unit, go back to page 5.

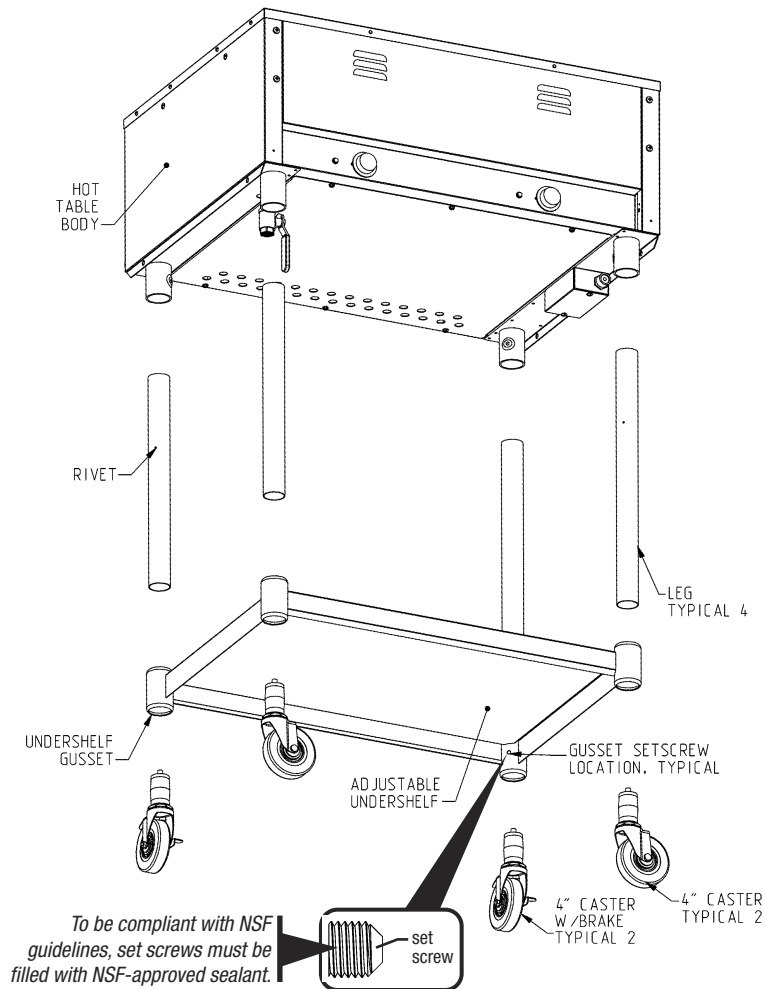

Note: Casters with brake typically go at the REAR of the unit.

1. After removing crate above shipping pallet, gently lay the unit onto its back.

Caution: Use cardboard or other material to prevent scratching.

2. Install legs into undershelf gussets with feet to underside of shelf. Loosely tighten set screws on undershelf.

3. Work legs into gussets on underside of unit and tighten set screw securely.

4. Adjust undershelf to desired height and tighten setscrews securely.

5. Insert caster stem into bottom of leg, and use a hammer or mallet to drive in.

6. Place table upright.

(continued on next page)

Electric Hot Food Table with Sealed-in Wells (SHT Series)

ASSEMBLY INSTRUCTIONS

Assemble the cutting board and plate shelf.

Refer to the illustration below and follow the assembly instructions.

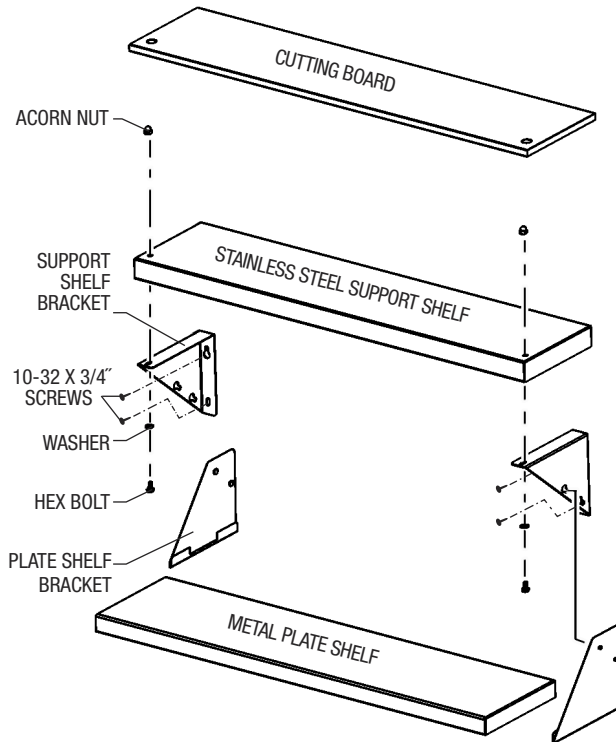

1. Attach support shelf brackets to support shelf, using acorn nuts, washers, bolts and predrilled holes.
Note: acorn nuts must be at the top.
2. Install 1/4"-20 x 3/4" screws into threaded fasteners on hot food table. Do not tighten.
3. Align keyholes in mounting brackets with screws and mount support shelf/bracket assembly to table. Tighten screws.
4. Hook metal plate shelf into bottom flange of plate shelf brackets.
5. Using keyholes on support shelf brackets, mount plate shelf/bracket assembly onto support shelf/bracket assembly.
6. Align holes in cutting board with acorn nuts, and place cutting board onto support shelf.

(continued on back page) 

AutoFill® Water System

INSTRUCTIONS

1. Attach a continuous flowing hot water source to the $\frac{3}{8}$ " compression water connection inlet.
2. Screw the barbed fitting into the drain line and connect a $\frac{1}{2}$ " tube for the overflow drain. run to an appropriate floor sink.
3. Plug unit into proper power source stated on model/serial plate. Turn water source on and the AutoFill® ON/OFF switch to "ON". (Remember that the solenoid will make a "pop" sound the first time this is turned on.) The AutoFill® system will fill and maintain the proper water level in all wells. If there is a desire to run the unit without automatically filling the wells with water, simply turn the ON/OFF switch to the "OFF" position. The AutoFill® system runs independently of the hot wells, so the wells are still operational.

For further details about the AutoFill® Water System, call the factory at 1-800-441-8440.

