

Adjustable Wall Mounts

For Shelving That Does Not Need Mid Brackets

ASSEMBLY INSTRUCTIONS

For shelving that requires mid brackets, see inside.

CAUTION

INSPECT CONTENTS IMMEDIATELY AND FILE CLAIM WITH DELIVERING CARRIER FOR ANY DAMAGE.
SAVE YOUR BOX AND ALL PACKING MATERIALS.
YOU ARE RESPONSIBLE FOR DAMAGE TO YOUR UNIT IF RETURNED IMPROPERLY PACKED.

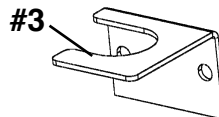
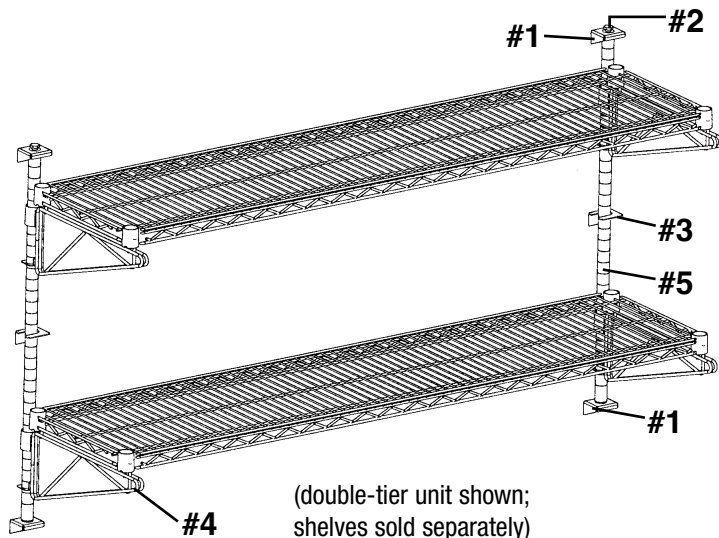

Parts List

#	qty	part #	description
#1	4	A203060	top/bottom support
#2	4	303999	bolt 3/8-16 x 1 1/2"
#3	2	A203059**	center support bracket**
#4	4	*	post-wall bracket
#5	2 or 3*	*	posts

* Quantities and part numbers vary, depending on what is ordered.

** Center support brackets are for multi-shelf units only.

Centerline Chart

Shelf Length	C.L.
24"	.22 1/16"
30"	.28 7/16"
36"	.34 1/16"
42"	.40 1/16"
48"	.46 1/16"
54"	.52 1/16"
60"	.58 1/16"
72"	.70 1/16"

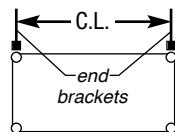

1) Centerline

Refer to "Centerline Chart" at left to determine proper centerline distances between posts.

2) Top & Bottom Supports

- Mark bottom support location at desired height (see *figure 1*)—using a level to ensure support is level—and then screw* bottom support into wall.
- To determine top support location, bolt the post to the bottom support on the wall, then bolt the top support to the post (see *figure 2*). **IMPORTANT:** Use a level to ensure post is straight.
- Mark top support location. Disassemble the post and supports. Screw* top support into wall (see *figure 1*).
- Based on "Centerline Chart," measure and mark locations of the other pair of supports, and then screw* supports into wall.

IMPORTANT NOTE: Depending on construction of wall, supports should be attached to wall studs, in-wall grounds (wall backing) of plywood or sheet metal, or solid part of brick or concrete wall with appropriate fasteners. Failure to use appropriate fasteners could result in collapse and personal injury. Eagle Group cannot be held responsible for failure of the device or any other devices due to improper installation. Also, it is your responsibility to make certain the mounting surface and method of mounting are suitable to support the anticipated weight which will be placed on this unit.

* Screws not included for top/bottom supports.

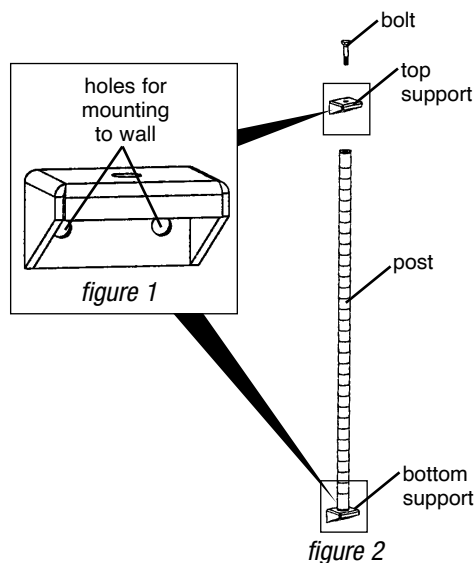

(continued on Page 2)

EG9875 Revised 03/24



• 100 Industrial Boulevard, Clayton, Delaware 19938-8903 U.S.A.
• Phone: 302/653-3000 • 800/441-8440 • Fax: 302/653-2065
• www.eaglegrp.com • www.eaglehmc.com

Adjustable Wall Mounts

For Shelving That Does Not Need Mid Brackets

ASSEMBLY INSTRUCTIONS

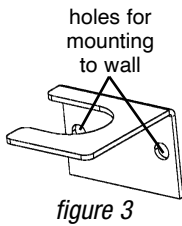

figure 3

3) Center Brackets for Multi-Tier Units

(Note: If you are installing a single-shelf unit, then proceed to Step 4.)

Install center bracket at desired location (see figure 3). We recommend that the bracket be positioned towards the center of the post for extra support.

BEFORE YOU CONTINUE, PLEASE NOTE...

Open box(es) of wire shelving* and set aside. You will find plastic split sleeves (pack of four per shelf), which you will need in order to complete **Step 4** below.

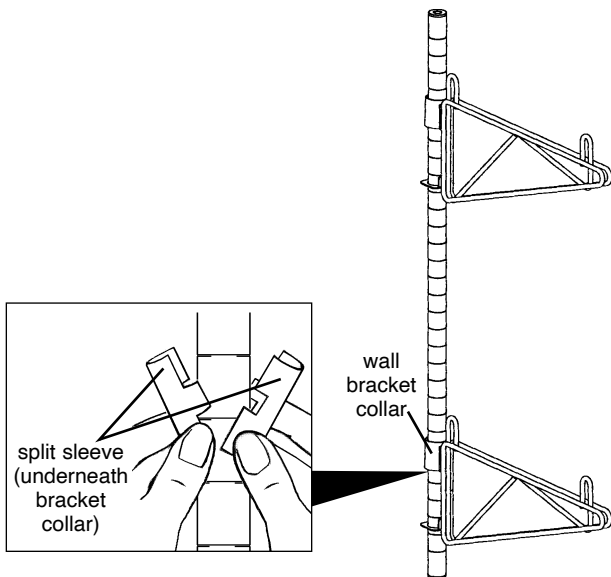

figure 4

4) Shelf Brackets

- Snap the plastic split sleeve onto the post where you want the shelf to rest (the wider part of the taper on the split sleeve faces the bottom of the post).

(Note: If you are installing a multi-tier unit, then start at the bottom of the post.)

- Slide the wall bracket collar (see figure 4) over top of post and down onto the plastic split sleeve. Repeat for each shelf bracket.

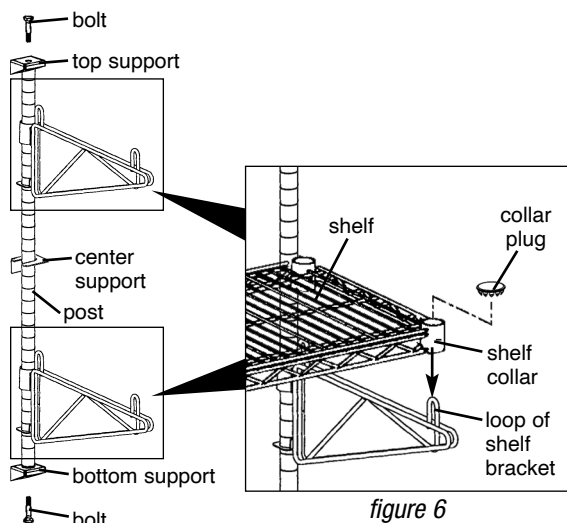

figure 5

figure 6

5) Posts & Shelves*

- Install post/bracket assemblies to supports, using bolts provided (see figure 5).
- Lay shelf* on top of wall brackets, and cover shelf collar openings with collar plugs (see figure 6).

* Shelves sold separately.



Adjustable Wall Mounts

For Shelving That Requires Mid Brackets

ASSEMBLY INSTRUCTIONS

For shelving that does not require mid brackets, see front page.

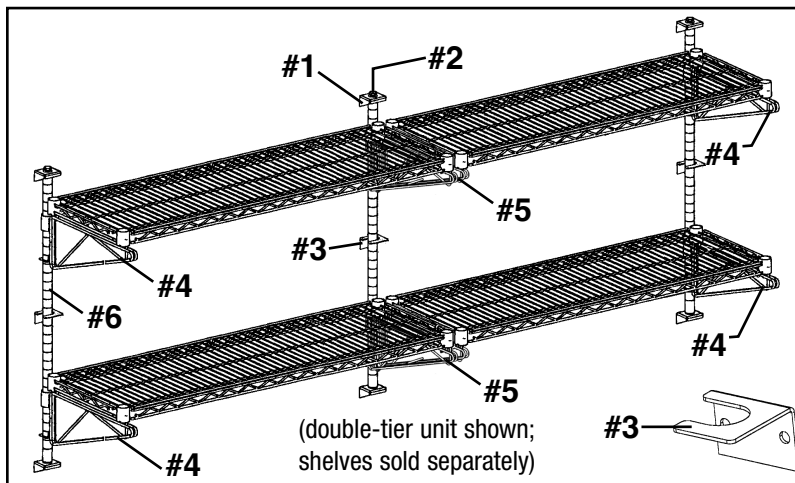

Parts List

#	qty	part #	description
#1	*	A203060	top/bottom support
#2	*	303999	bolt 3/8-16 x 1 1/4"
#3	*	A203059**	center support bracket**
#4	*	PWB14C	post-wall end bracket
#5	*	*	post-wall mid bracket
#6	*	*	posts

* Quantities and/or part numbers vary, depending on what is ordered.

** Center support brackets are for multi-shelf units only.

Centerline Charts

(for units with only one mid bracket)

Shelf Length	C.L.
24"	.23 ³ / ₁₆ "
30"	.29 ⁹ / ₁₆ "
36"	.35 ³ / ₁₆ "
42"	.41 ³ / ₁₆ "
48"	.47 ³ / ₁₆ "
54"	.53 ³ / ₁₆ "
60"	.59 ³ / ₁₆ "
72"	.71 ³ / ₁₆ "

(for units with two or more mid brackets)

Shelf Length	C.L.
24"	.23 ¹⁵ / ₁₆ "
30"	.29 ¹⁵ / ₁₆ "
36"	.35 ¹⁵ / ₁₆ "
42"	.41 ¹⁵ / ₁₆ "
48"	.47 ¹⁵ / ₁₆ "
54"	.53 ¹⁵ / ₁₆ "
60"	.59 ¹⁵ / ₁₆ "
72"	.71 ¹⁵ / ₁₆ "

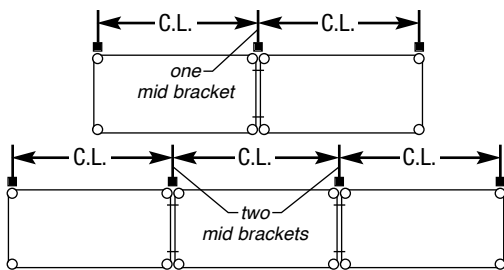

1) Centerline

Refer to chart at left to determine proper centerline distances between posts.

2) Top & Bottom Supports

- Mark bottom support location at desired height (see *figure 1*)—using a level to ensure support is level—and then screw* bottom support into wall.
- To determine top support location, bolt the post to the bottom support on the wall, then bolt the top support to the post (see *figure 2*). IMPORTANT: Use a level to ensure post is straight.
- Mark top support location. Disassemble the post and supports. Screw* top support into wall (see *figure 1*).
- Based on "Centerline Chart," measure and mark locations of additional pair(s) of top/bottom supports, and then screw* top/bottom supports into wall.

IMPORTANT NOTE: Depending on construction of wall, supports should be attached to wall studs, in-wall grounds (wall backing) of plywood or sheet metal, or solid part of brick or concrete wall with appropriate fasteners. Failure to use appropriate fasteners could result in collapse and personal injury. Eagle Group cannot be held responsible for failure of the device or any other devices due to improper installation. Also, it is your responsibility to make certain the mounting surface and method of mounting are suitable to support the anticipated weight which will be placed on this unit.

* Screws not included for top/bottom supports.

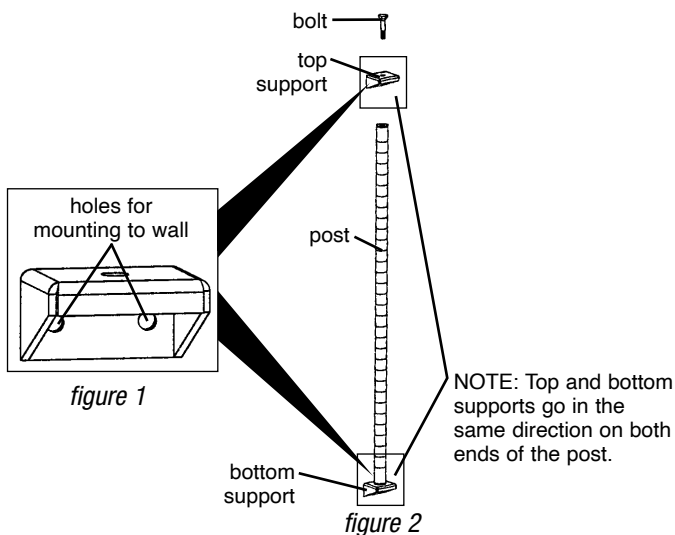

(continued on back page)

Adjustable Wall Mounts

For Shelving That Requires Mid Brackets

ASSEMBLY INSTRUCTIONS

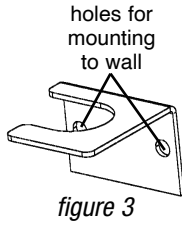

figure 3

3) Center Brackets for Multi-Tier Units

(Note: If you are installing a single-shelf unit, then proceed to Step 4.)

Install center bracket at desired location (see figure 3). We recommend that the bracket be positioned towards the center of the post for extra support.

BEFORE YOU CONTINUE, PLEASE NOTE...

Open box(es) of wire shelving* and set aside. You will find plastic split sleeves (pack of four per shelf), which you will need in order to complete Step 4 below.

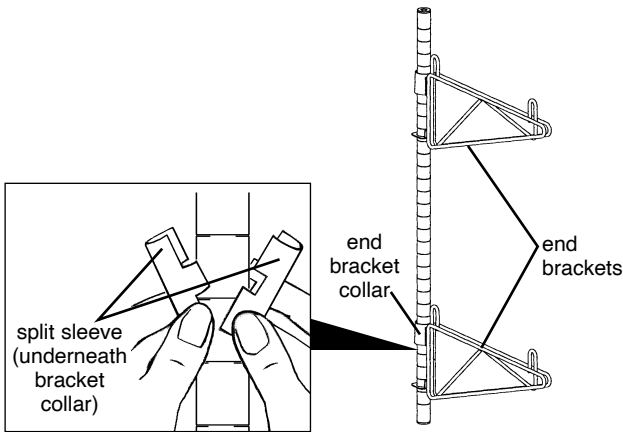

figure 4

4) End Brackets

- Snap the plastic split sleeve onto the post where you want the shelf to rest (the wider part of the taper on the split sleeve faces the bottom of the post).

(Note: If you are installing a multi-tier unit, then start at the bottom of the post.)

- Slide the end bracket collar (see figure 4) over top of post and down onto the plastic split sleeve. Repeat for each shelf bracket.

Repeat this step to assemble mid brackets to remaining post(s).

5) Posts & Shelves*

- Install post/bracket assemblies to supports using bolts provided (see figure 5). Make sure the post(s) with mid brackets is in the middle.
- Lay each shelf* on top of wall brackets, and cover shelf collar openings with collar plugs (see figure 6).

* Shelves sold separately.

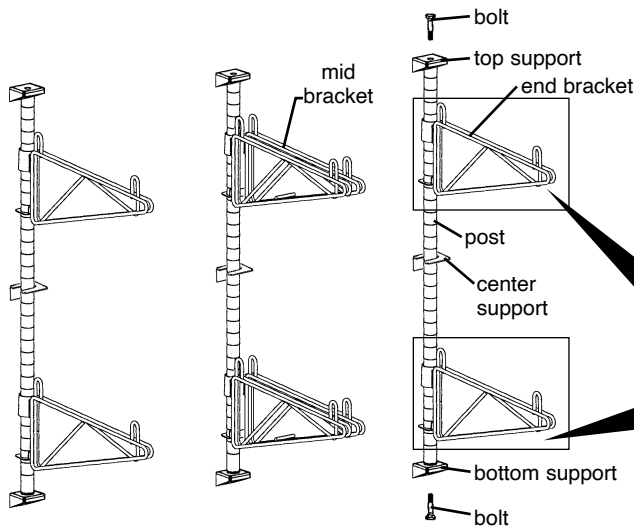

figure 5

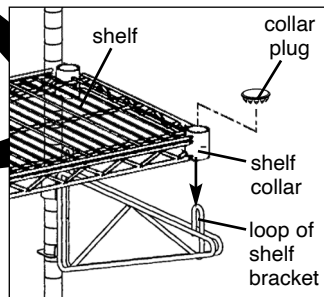

figure 6

EAGLE
GROUP
Profit from the Eagle Advantage®

• 100 Industrial Boulevard, Clayton, Delaware 19938-8903 U.S.A.
• Phone: 302/653-3000 • 800/441-8440 • Fax: 302/653-2065
• www.eaglegrp.com • www.eaglehmc.com

Eagle Foodservice Equipment, Eagle MHC, and SpecFAB® are divisions of Eagle Group. ©2024 by the Eagle Group

(End)