

# KOBALT™

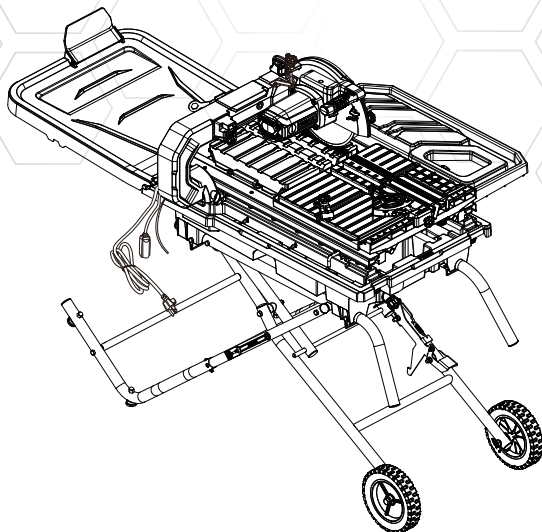

ITEM #5202571

## 10-IN FOLDING WET TILE SAW WITH STAND

MODEL #SC2502LW

Español p. 49

KOBALT and logo design are trademarks or registered trademarks of LF, LLC. All Rights Reserved.

**ATTACH YOUR RECEIPT HERE**

Serial Number \_\_\_\_\_ MFG Date \_\_\_\_\_ Purchase Date \_\_\_\_\_



**Questions, problems, missing parts?** Before returning to your retailer, call our customer service department at 888-3KOBALT (888-356-2258), 8 a.m. - 8 p.m., EST, Monday - Sunday. You could also contact us at [partsplus@lowes.com](mailto:partsplus@lowes.com).

AS22684

## TABLE OF CONTENTS

Product Specifications.....	2
Package Contents.....	3
Know Your Tile Saw.....	6
Important Safety Information.....	8
Electrical Safety Information.....	11
Preparation.....	14
Assembly Instructions.....	15
Adjustment Instructions.....	32
Operating Instructions.....	35
Care And Maintenance.....	42
Troubleshooting.....	45
Replacement Parts List.....	46
Warranty.....	48

## PRODUCT SPECIFICATIONS

DESCRIPTION	SPECIFICATIONS
Power Supply	120 V, 60 Hz
Motor	15 A
No Load Speed	4,000 RPM
Wheel	10 in. x 5/8 in. (arbor)
Maximum Depth of Cut	3-3/4 in.
Rip Capacity (tile size)	40 in.
Diagonal Capacity (tile size)	24 in.
Bevel Angles	0°, 22.5°, 45°

## PACKAGE CONTENTS

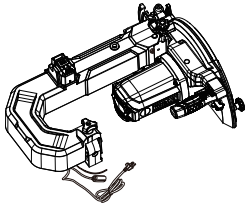

**A**

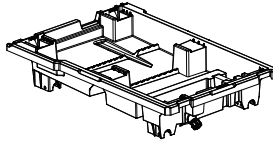

**B**

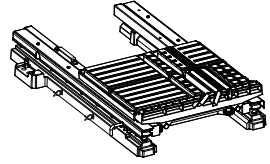

**C**

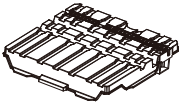

**D**



**E**

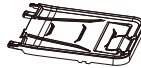

**F**



**G**

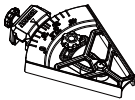

**H**



**I**

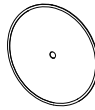

**J**

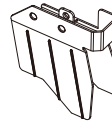

**K**

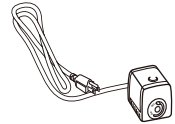

**L**

PART	DESCRIPTION	QUANTITY
A	Cutting head assembly	1
B	Water tray	1
C	Table frame	1
D	Rear table extension	1
E	Side table extension	1
F	Rear water catch tray	1
G	Side water catch tray	1
H	Rip/Angle guide	1
I	Tile clamp	1
J	Cutting wheel	1
K	Side splash guard	1
L	Water pump	1

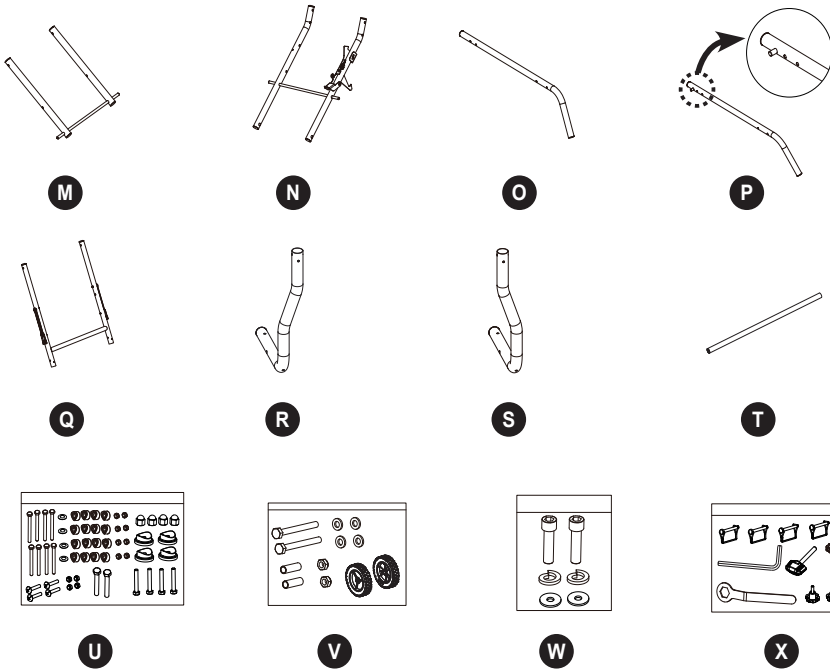

PART	DESCRIPTION	QUANTITY
M	Center brace	1
N	Inner leg assembly	1
O	Left handle	1
P	Right handle	1
Q	Upper outer tube assembly	1
R	Left lower outer tube	1
S	Right lower outer tube	1
T	Lower brace support	1
U	Stand hardware bag	1
V	Wheel hardware bag	1
W	Cutting head assembly locking hardware bag	1
X	Wheel wrench hardware bag	1

**HARDWARE CONTENTS (not shown to actual size)**

BAG	PART	DESCRIPTION	QUANTITY
U	aa	M8*1.25-95 Bolt	8
	bb	Spacer	16
	cc	M8*1.25 T=8 Nut	8
	dd	M6*1.0-40 Bolt	4
	ee	Foot pad	4
	ff	M6*1.0 T=13 Crown nut	4
	gg	M5*0.8-40 Screw	4
	hh	M5*0.8 T=5 Nut	4
	ii	M8*1.25-45 Bolt	2
	jj	φ8.2*16-0.35 Spring washer	4
BAG	PART	DESCRIPTION	QUANTITY
V	kk	M10*1.5-95 Hex head bolt	2
	mm	φ10*20-3 Washer	4
	nn	M10-1.5 T=10 Lock nut	2
	oo	Sleeve	2
BAG	PART	DESCRIPTION	QUANTITY
W	pp	M12*1.75-45 Bolt	2
	qq	φ12 Spring washer	2
	rr	φ12*21-2 Flat washer	2
BAG	PART	DESCRIPTION	QUANTITY
X	ss	Hitch pin	4
	tt	1/4*3/4-1/16 Flat washer	1

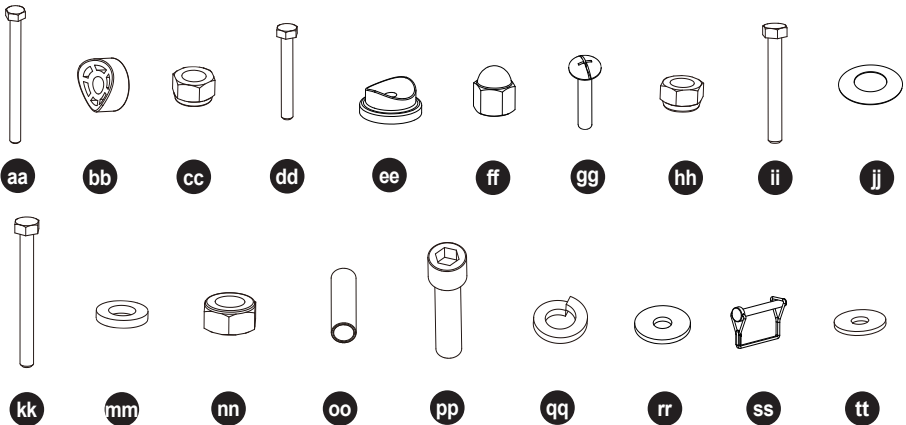

# KNOW YOUR TILE SAW

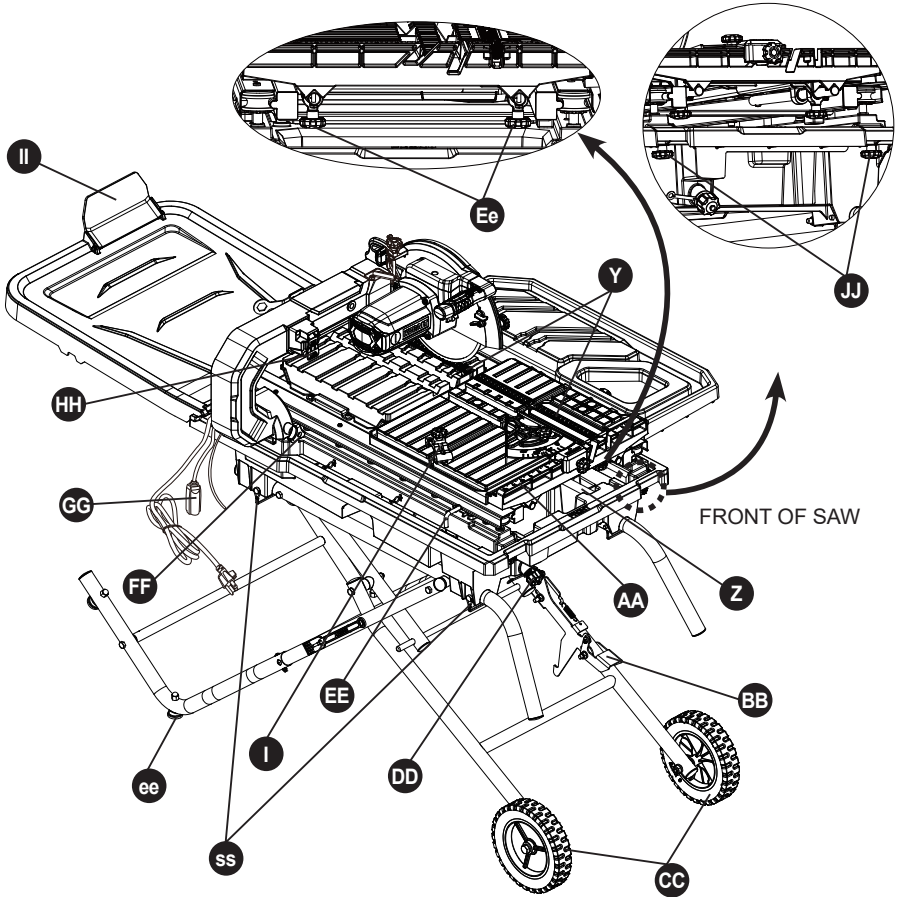

PART	DESCRIPTION
ee	Foot pads
ss	Hitch pins
I	Tile clamp
Y	Table inserts
Z	Filter
AA	Sliding T-fence extension
BB	Foot release lever
CC	Wheels

PART	DESCRIPTION
DD	Drain plug
EE	Frame locking lever
FF	Arm folding lock knob
GG	Power cord receptacle
HH	ON/OFF switch
II	Small rear flap
JJ	Water tray lock knobs
Ee	Sliding T-fence extension lock knobs

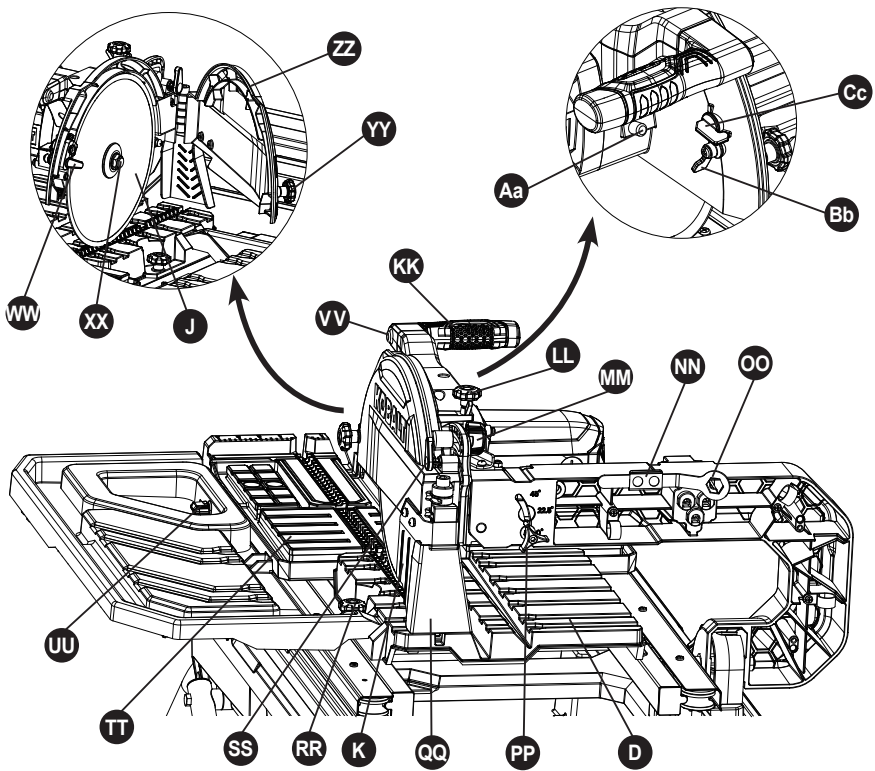

PART	DESCRIPTION
D	Rear table extension
J	Cutting wheel
K	Side splash guard
KK	Motor handle
LL	Cutting depth stop knob
MM	Cutting head lock knob
NN	Wheel wrench storage
OO	Wheel wrench
PP	Bevel lock knob
QQ	Rear splash guard
RR	Rear table extension lock knob

PART	DESCRIPTION
SS	Hold-down latch
TT	Sliding table
UU	Side table extension lock knob
VV	LED light ON/OFF switch
WW	Water nozzles
XX	Arbor bolt
YY	Wheel guard lock knob
ZZ	Upper wheel guard
Aa	Arbor lock button
Bb	Water angle control
Cc	Water volume control

## IMPORTANT SAFETY INFORMATION

---

### WARNING

To reduce risk of injury:

- Before any use, be sure everyone using this tool reads and understands all safety instructions and other information contained in this manual.
- Save these instructions and review frequently prior to use and in instructing others.
  
- **Keep guards in place** and in working order.
- **Remove adjusting keys and wrenches.** Form habit of checking to see that keys and adjusting wrenches are removed from tool before turning it on.
- **Keep work area clean.** Cluttered areas and benches invite accidents.
- **Don't use in dangerous environment. Don't use power tools in damp or wet locations, or expose them to rain.** Keep work area well lighted.
- **Keep children away.** All visitors should be kept safe distance from work area.
- **Make workshop kid proof** with padlocks, master switches, or by removing starter keys.
- **Don't force tool.** It will do the job better and safer at the rate for which it was designed.
- **Use right tool.** Don't force tool or attachment to do a job for which it was not designed.
- **Use proper extension cord.** Make sure your extension cord is in good condition. When using an extension cord, be sure to use one heavy enough to carry the current your product will draw. An undersized cord will cause a drop in line voltage resulting in loss of power and overheating. Minimum Gauge for Cord Sets shows the correct size to use depending on cord length and nameplate ampere rating. If in doubt, use the next heavier gauge. The smaller the gauge number, the heavier the cord.
- **Wear proper apparel.** Do not wear loose clothing, gloves, neckties, rings, bracelets, or other jewelry which may get caught in moving parts. Nonslip footwear is recommended. Wear protective hair covering to contain long hair.
- **Always use safety glasses.** Also use face or dust mask if cutting operation is dusty. Everyday eyeglasses only have impact resistant lenses, they are NOT safety glasses.
- **Secure work.** Use clamps or a vise to hold work when practical. It's safer than using your hand and it frees both hands to operate tool.
- **Don't overreach.** Keep proper footing and balance at all times.
- **Maintain tools with care.** Keep tools sharp and clean for best and safest performance. Follow instructions for lubricating and changing accessories.
- **Disconnect tools** before servicing; when changing accessories, such as wheels, bits, cutters, and the like.
- **Reduce the risk of unintentional starting.** Make sure switch is in off position before plugging in.
- **Use recommended accessories.** Consult the owner's manual for recommended accessories. The use of improper accessories may cause risk of injury to persons.
- **Never stand on tool.** Serious injury could occur if the tool is tipped or if the cutting tool is unintentionally contacted.
- **Check damaged parts.** Before further use of the tool, a guard or other part that is damaged should be carefully checked to determine that it will operate properly and perform its intended function – check for alignment of moving parts, binding of moving parts, breakage of parts, mounting, and any other conditions that may affect its operation. A guard or other part that is damaged should be properly repaired or replaced.
- **Direction of feed.** Feed work into a wheel or cutter against the direction of rotation of the wheel or cutter only.
- **Never leave tool running unattended. Turn power off.** Don't leave tool until it comes to a complete stop.

## SAFETY INSTRUCTIONS FOR TILE SAWS

### CAUTION

- Wear appropriate hearing protection during use. Under some conditions and duration of use, noise from this product may contribute to hearing loss.
- Do not connect unit to electrical power source until complete instructions are read and understood.
- **Don't** operate saw without the cutting wheel cover in place.
- Clean tile saw after each use for optimal operation.
- Use safety equipment. Always wear eye protection. Dust mask, non-skid safety shoes, hard hat, or hearing protection must be used for appropriate conditions.
- Keep hands out of path of the cutting wheel. Never cut a piece where hand would be 3" (76 mm) or less from the cutting wheel.
- Do not perform any operation freehand, that is without holding the workpiece firmly against the fence or edge guide.
- Never reach in back of the cutting wheel.
- **Don't** - Cut dry. If the cutting wheel is not cooled with water, serious damage will occur. Dry cutting will increase exposure to harmful airborne dust.
- Turn off the tool and wait for the cutting wheel to stop before moving the workpiece or changing settings.
- To reduce risk of injury, return the table to it's forward position after each cut.
- **Do** - Use rear and side table extensions to support large tile.
- **Do** - Make certain the cutting wheel rotates in the correct direction as indicated by the arrow on the cutting wheel.
- **Do** - Be sure all clamp handles and knobs are tight before starting any operation.
- **Do** - Be sure all cutting wheel and clamp washers are clean and recessed sides of collars are against the cutting wheel. Tighten arbor nut securely.
- **Do** - Keep the cutting wheel properly aligned.
- **Do** - Keep the motor air slots free of chips and dirt.
- **Do** - Always empty water from the reservoir and disconnect from the power source before transporting. Water can splash into electrical components.
- **Do** - Keep hands out of the path of the cutting wheel.
- **Do** - Shut off power, disconnect cord from power source and wait for the cutting wheel to stop before servicing, adjusting tool or changing cutting wheel.
- **Don't** - Attempt to operate on anything but designated voltage. Incorrect voltage may result in shock, fire, or unpredictable operation.
- **Don't** - Operate unless all knobs and clamps are tight.
- **Don't** - Use cutting wheels larger or smaller than those which are recommended.
- **Don't** - Force cutting action. Allow motor to reach full speed before cutting. Stalling or partial stalling of motor can cause major damage.
- **Don't** - Use metal cutting abrasive wheels. The excessive heat and abrasive particles generated by them will damage the saw.
- **Do** - Use continuous rim wheels only, no serrated edges or toothed cutting wheels.
- **Don't** - Allow anyone to stand behind saw.
- **Don't** - Place either hand in the cutting wheel area when the saw is connected to the power source.
- **Don't** - Use cutting wheels rated less than 4000 R.P.M.
- **Don't** - Place hands closer than 3" (76 mm) from the cutting wheel.
- **Don't** - Reach behind or underneath the saw unless it is turned off and unplugged.
- **Don't** - Move either hand from saw or workpiece until the cutting wheel has stopped.
- **Secure work.** Always place tile flat on table and securely against fence.
- Never use a pan heater or other heat source for heating water. Damage to the tool, fire or personal injury could result.
- If the plug or receptacle does get wet, **Don't** unplug the cord. Disconnect the fuse or circuit breaker that supplies power to the tool. Then unplug and examine for presence of water in the receptacle.

## PROPOSITION 65 WARNING

 **WARNING:** Some dust created by power sanding, sawing, grinding, drilling, and other construction activities contains chemicals known to the State of California to cause cancer, birth defects or other reproductive harm. Some examples of these chemicals are:

- Lead from lead-based paints,
- Crystalline silica from bricks and cement and other masonry products, and
- Arsenic and chromium from chemically treated lumber.

Your risk from these exposures varies depending on how often you do this type of work. To reduce your exposure to these chemicals: work in a well-ventilated area and work with approved safety equipment, such as those dust masks that are specially designed to filter out microscopic particles.

Handling the power cord on this product may expose you to chemicals known to the state of California to cause cancer and birth defects or other reproductive harm. Wash hands after handling.

**For more information go to: [www.P65Warnings.ca.gov](http://www.P65Warnings.ca.gov)**



**READ INSTRUCTION MANUAL:** To reduce the risk of injury, user and all bystanders must read instruction manual before using this product.

## ELECTRICAL SAFETY INFORMATION

---

### POWER SUPPLY AND MOTOR SPECIFICATIONS

 **WARNING:** To avoid electrical hazards, fire hazards, or damage to the tool, use proper circuit protection. Use a separate electrical circuit for your tool. Your tile saw is wired at the factory for 120 V operation. Connect to a 120 V, 15 Amp circuit and use a 15 Amp time delay fuse or circuit breaker. To avoid shock or fire, if power cord is worn, cut, or damaged in any way, have it replaced immediately.

### GROUNDING INSTRUCTIONS

 **WARNING:** This tool must be grounded while in use to protect the operator from electrical shock.

**IN THE EVENT OF A MALFUNCTION OR BREAKDOWN,** grounding provides a path of least resistance for electric currents and reduces the risk of electric shock. This tool is equipped with an electrical cord that has an equipment-grounding conductor and a grounding plug. The plug must be plugged into a matching receptacle that is properly installed and grounded in accordance with all local codes and ordinances.

**DO NOT MODIFY THE PLUG PROVIDED.** If it will not fit the receptacle, have the proper receptacle installed by a qualified electrician.

**IMPROPER CONNECTION** of the equipment grounding conductor can result in risk of electric shock. The conductor with the green insulation (with or without yellow stripes) is the equipment grounding conductor. If repair or replacement of the electrical cord or plug is necessary, do not connect the equipment grounding conductor to a live terminal.

**CHECK** with a qualified electrician or service person if you do not completely understand the grounding instructions, or if you are not certain the tool is properly grounded.

**USE only 3-wire extension cords that have three-pronged grounding plugs with three-pole receptacles that accept the tool's plug. Repair or replace damaged or worn cords immediately.**

Use a separate electrical circuit for your tool. This circuit must not be less than #14 wire and should be protected with a 15 Amp time delay fuse. Before connecting the motor to the power line, make sure the switch is in the off position and the electric current is rated the same as the current stamped on the motor nameplate. Running at a lower voltage will damage the motor.

### GUIDELINES FOR EXTENSION CORDS

**USE THE PROPER EXTENSION CORD.** Make sure your extension cord is in good condition. Use an extension cord heavy enough to carry the current your product will draw. An undersized cord will cause a drop in line voltage resulting in loss of power, overheating and burning out of the motor. The table below shows the correct size to use depending on cord length and nameplate ampere rating. If in doubt, use the next heavier gauge. The smaller the gauge number, the heavier the cord.

Make sure your extension cord is properly wired and in good condition. Always replace a damaged extension cord or have it repaired by a qualified technician before using it. Protect your extension cords from sharp objects, excessive heat and damp or wet areas.

MINIMUM GAUGE FOR EXTENSION CORDS (AWG)				
(When using 120 volts only)				
Ampere Rating		Total length of Cord		
More Than	Not More Than	25 ft.	50 ft.	100 ft. 150 ft.
0	6	18	16	16 14
6	10	18	16	14 12
10	12	16	16	14 12
12	16	14	12	Not Recommended

**⚠ WARNING:** Do not expose to rain or use in damp locations.

This tool is intended for use on a circuit that has a receptacle like the one illustrated in Fig. A. Fig. A shows a three-pronged electrical plug and receptacle that has a grounding conductor. If a properly grounded receptacle is not available, an adapter (Fig. B) can be used to temporarily connect this plug to a two-contact grounded receptacle.

The adapter (Fig. B) has a rigid lug extending from it that **MUST** be connected to a permanent earth ground, such as a properly grounded receptacle box.

**⚠ CAUTION:** In all cases, make certain the receptacle is properly grounded. If you are not sure, have a qualified electrician check the receptacle.

**Fig. A**

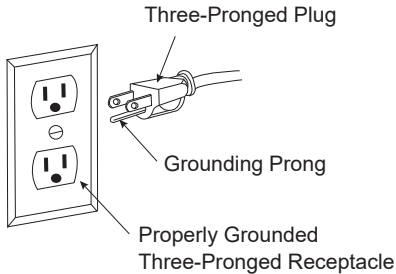

**Fig. B**

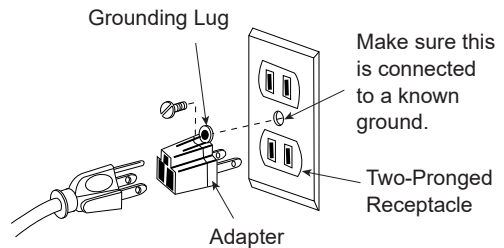

**Fig. C**

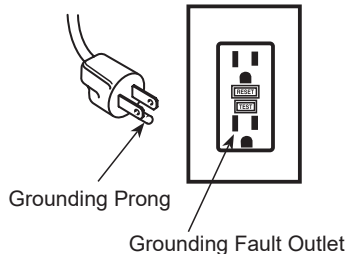

## POSITION OF TILE SAW

To avoid the possibility of the appliance plug or receptacle getting wet, position the tile saw to one side of a wall-mounted receptacle to prevent water from dripping onto the receptacle or plug. The user should arrange a "drip loop" in the cord connecting the saw to a receptacle (see Fig. D). The "drip loop" is that part of the cord below the level of the receptacle, or connector if an extension cord is used, to prevent water traveling along the cord and coming in contact with the receptacle.

If the plug or receptacle does get wet, DO NOT unplug the cord. Disconnect the fuse or circuit breaker that supplies power to the tool. Then, unplug and examine for presence of water in the receptacle.

## EXTENSION CORDS

1. Use only extension cords that are intended for outdoor use. These extension cords are identified by a marking "Acceptable for use with outdoor appliances; store indoors while not in use." Use only extension cords having an electrical rating not less than the rating of the product.

Do not use damaged extension cords. Examine extension cord before using and replace if damaged.

Do not abuse extension cords and do not yank on any cord to disconnect. Keep cord away from heat and sharp edges.

Always disconnect the extension cord from the receptacle before disconnecting the product from the extension cord.

2. **⚠ WARNING:** To reduce the risk of electrocution, keep all connections dry and off the ground. Do not touch plug with wet hands.
3. Ground Fault Circuit Interrupter (GFCI) (not included) protection should be provided on the circuit(s) or Fig. C outlet(s) to be used for the tile saw. Receptacles are available having built-in GFCI protection and may be used for this measure of safety.

Fig. D

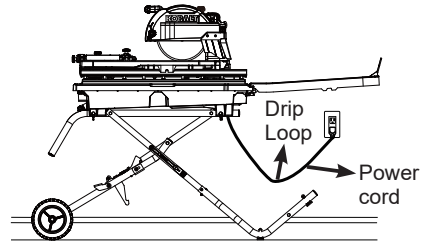

## **PREPARATION**

---

Before beginning assembly or operation of the product, make sure all parts are present. Compare parts with package contents list and hardware contents list on pages 3 to 5. If any part is missing or damaged, do not attempt to assemble, install or operate the product.

**Estimated Assembly Time: 60 minutes.**

Tools needed for assembly (included): Wheel Wrench, 10 mm Hex Wrench.

Tools required for assembly and adjustment (not included): Adjustable Wrench, 3 mm Hex Key, 13 mm Wrench, 17 mm Wrench, Framing Square, Combination Square, Phillips Screwdriver.

## ASSEMBLY INSTRUCTIONS

**⚠ WARNING:** To avoid injury, do not connect this tile saw to a power source until it is completely assembled and you have read and understood the instruction manual.

### UNPACKING YOUR TILE SAW

Carefully unpack the tile saw and all its parts, and compare against the list and illustration on pages 3 to 5. With the help of an assistant, place the saw on a secure surface and examine it carefully.

### ⚠ WARNING

- To avoid injury from unexpected starting or electrical shock, do not plug the power cord into a source of power during unpacking and assembly. The cord must remain unplugged whenever you are adjusting/assembling the tile saw.
- The tile saw is heavy and should be lifted with care. If needed, get the assistance of someone to lift and move the tile saw.
- If any part is missing or damaged, do not attempt to assemble the tile saw, or plug in the power cord until the missing or damaged part is correctly replaced.
- DO NOT use this product if any loose parts on the Package Contents or Hardware Contents sections are already assembled to your product when you unpack it. Parts on this list are not assembled to the product by the manufacturer and require customer installation. Use of a product that may have been improperly assembled could result in serious injury.

If any parts are damaged or missing, please call 888-3Kobalt (888-356-2258) for assistance.

**⚠ WARNING:** Do not attempt to modify this tool or create accessories for use with this tool. Any such alteration or modification is misuse and could result in a hazardous condition leading to serious personal injury.

### ASSEMBLING THE STAND (FIG. 1, 2, 3, 4, 5, 6)

#### Assembling the wheels (Fig. 1) - BAG V

**NOTE:** Verify that the side of the wheel that has more spokes is facing inward toward the stand.

- Place the inner leg assembly (N) on the ground. Insert the sleeve (oo) into the hole (1) of the wheel (CC). Attach one wheel (CC) to one side of the inner leg assembly (N) using a hex bolt (kk), two flat washers (mm) and a lock nut (nn), as shown.
- Tighten using the adjustable wrench (not included) for the lock nut (nn) and the 17 mm wrench (not included) for the hex bolt (kk).  
**NOTE:** Do not overtighten, because doing so will not allow the wheel to turn.
- Repeat the above steps for assembling the other wheel to the other side of the inner leg assembly (N).

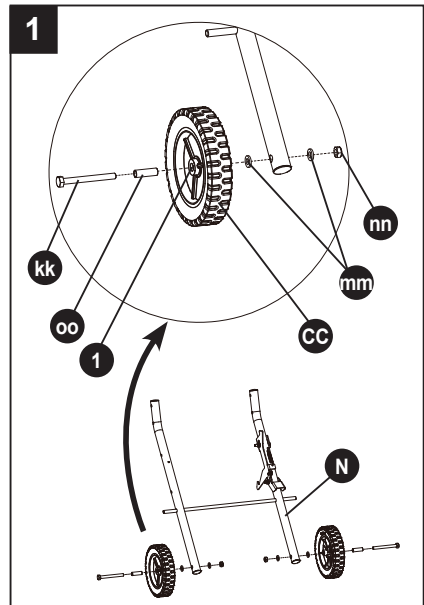

### Assembling the left and right outer tubes (Fig. 2) - BAG U

- Attach the left lower outer tube (R) to one side of the upper outer tube assembly (Q) using two screws (gg) and two lock nuts (hh), as shown.
- Tighten using the adjustable wrench (not included) for the nuts (hh) and the Phillips screwdriver (not included) for the screws (gg).
- Repeat the above steps to assemble the right lower outer tube.

### Assembling the foot pads (Fig. 2) - BAG U

- Attach one foot pad (ee) to the left lower outer tube (R) using one hex bolt (dd) and one crown nut (ff), as shown.
- Tighten using the adjustable wrench (not included) for the crown nut (ff) and the 10 mm wrench (not included) for the hex bolt (dd).
- Repeat the above steps to assemble the other three foot pads.

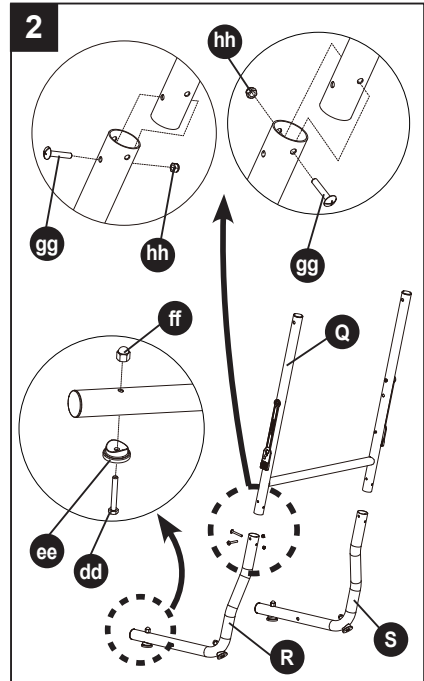

### Assembling the center brace to the inner leg assembly (Fig. 3) - BAG U

- Place the center brace (M) on top of the inner leg assembly (N) (curve side up) with the stop pin (1) under the foot release lever (BB). **NOTE:** The stop pins rest on top of the inner leg assembly.
- Attach the center brace (M) to the inner leg assembly (N) using two hex bolts (aa), two spring washers (jj), four small spacers (bb) and two nuts (cc), as shown. **NOTE:** The flat sides of two spacers should be placed against each other.
- Tighten with the adjustable wrench (not included) for the nuts (cc) and the 13 mm wrench (not included) for the hex bolts (aa). **NOTE:** Do not overtighten, because doing so will not allow the leg assembly to move.

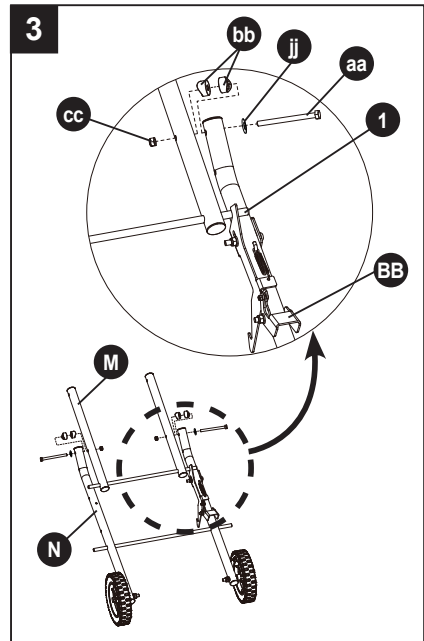

### Assembling the left and right outer tubes to the inner leg assembly (Fig. 4) - BAG U

- Pull the rubber strip (1) off the locking hook (2). This will expose the center hole on the outer tube.
- Position the inner leg assembly (N) and left outer tube (3) so that they resemble an "X".
- Attach the left outer tube (3) to the inner leg assembly (N) using a hex bolt (aa), a spring washer (jj), two small spacers (bb) and a nut (cc), as shown.
- Tighten with the adjustable wrench (not included) for the nut (cc) and the 13 mm wrench (not included) for the hex bolt (aa).  
**NOTE:** Do not overtighten, because doing so will not allow the leg assembly to move.
- Repeat the above steps to assemble the right outer tube to the inner leg assembly.

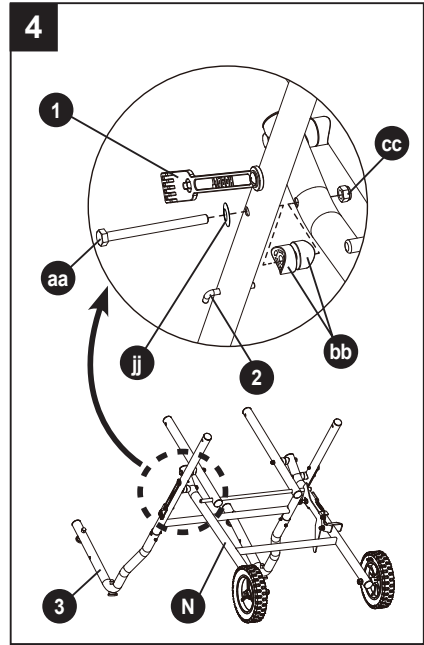

### Assembling the left and right handles (Fig. 5) - BAG U

**NOTE:** The handle with the tab should be installed on the right.

- Attach the left handle (O) to the left outer tube (1) and the center brace (M) using two hex bolts (aa), four small spacers (bb) and two nuts (cc), as shown.
- Tighten with the adjustable wrench (not included) for the nut (cc) and the 13 mm wrench (not included) for the hex bolt (aa).  
**NOTE:** Do not overtighten, because doing so will not allow the leg assembly to move.
- Repeat above steps for the right handle (P).

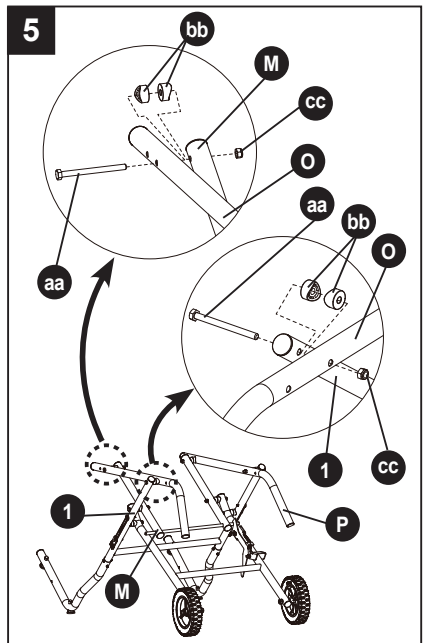

### Assembling the lower brace support (Fig. 6) - BAG U

- Attach the lower brace support (T) to the left and right outer tubes using two hex bolts (ii), as shown.
- Tighten the hex bolts (ii) with the adjustable wrench (not included).

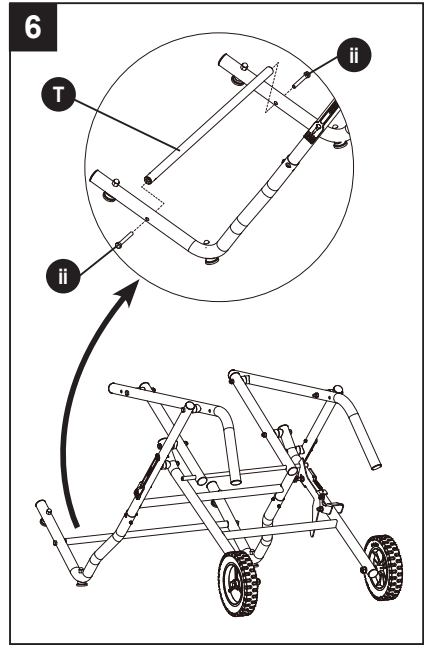

### INSTALLING THE WATER TRAY TO STAND (FIG. 7) - BAG X

- Place the water tray (B) on the stand. Align the four holes in the water tray (B) with the holes in the stand handles.
- Secure the water tray (B) to the stand using four hitch pins (ss).
- Insert the pin from the outside and then lock in place by inserting the end of the pin into the hook on the hitch pin, as shown in drawing.

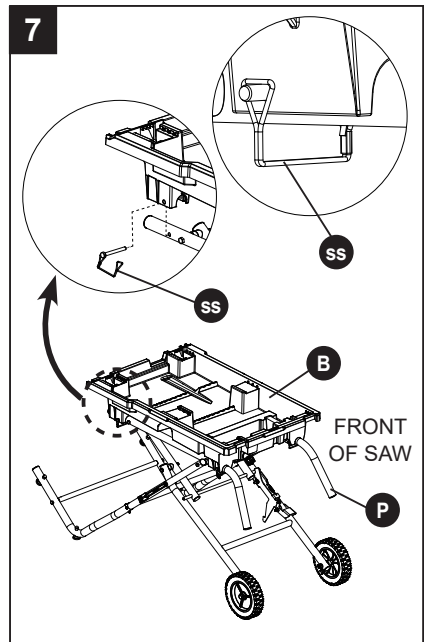

## INSTALLING THE CUTTING HEAD ASSEMBLY TO TABLE FRAME (FIG. 8) - BAG W

**NOTE:** The cutting head assembly and table frame are heavy and it is recommended to be transported with the help of 2 people, to safely move it.

- Place the table frame (C) and cutting head assembly (A) on a flat, secure surface.
- Align the holes in the cutting head assembly (A) with the holes on the table frame (C).

**NOTE:** Make sure that two location pins (1) are fully engaged with two holes (2) in the cutting head assembly (A).

- Thread two bolts (pp) through two spring washers (qq) and two flat washers (rr) into the holes under the table frame and into the cutting head assembly.
- Tighten the bolts using the provided 10 mm hex wrench (Gg).
- On the cutting head assembly, pull out the hold-down latch (SS) and grasp the motor handle (KK) to raise up the cutting head.
- Release the hold-down latch (SS) to lock into place and tighten the cutting head lock knob (MM) to secure the cutting head.

**NOTE:** Make sure the cutting head locking knob (MM) is fully engaged with the channel before locking.

- Pull out the arm folding lock knob (FF) and grasp the motor handle (KK) to raise the cutting head assembly up. Push in the arm folding lock knob (FF) and tighten it.

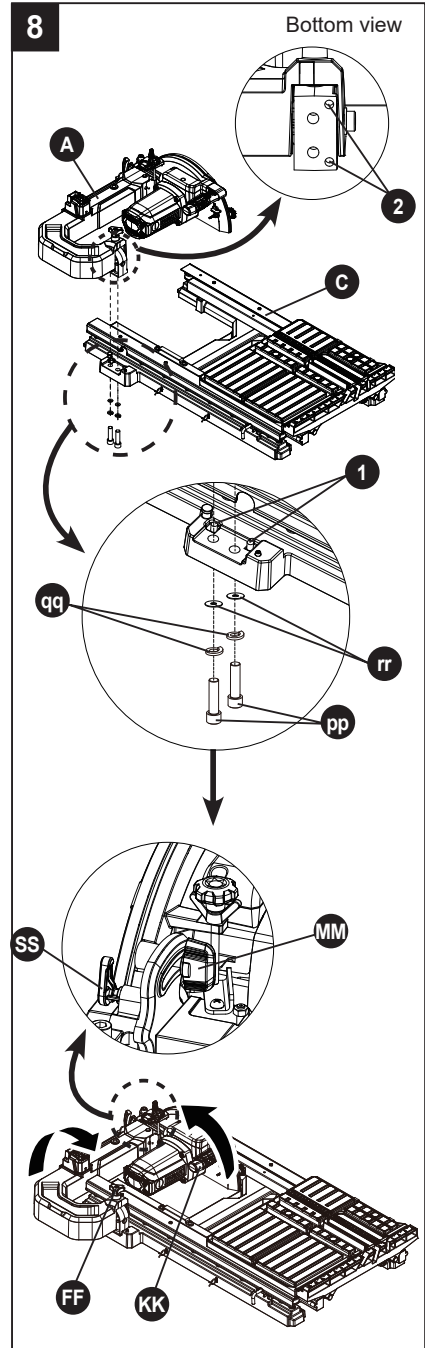

**INSTALLING THE CUTTING HEAD ASSEMBLY AND TABLE FRAME TO WATER TRAY (FIG. 9) - BAG X**

- Carefully lift the cutting head assembly and table frame over the water tray (B), as shown.  
**NOTE:** The cutting head assembly and table frame are heavy and it is recommended to be transported with the help of 2 people, to safely move it.
- Tilt the frame and insert heavy duty tabs (1) into the slot (2) on water tray (B) at the back of the unit.
- Secure the frame in place with two water tray lock knobs (JJ) at the front of the unit.

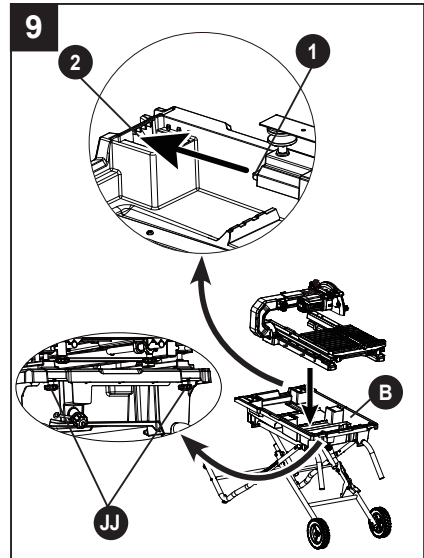

**INSTALLING THE WATER PUMP (FIG. 10)**

The water pump recirculates water from the water tray to the cutting wheel.

- Place the filter (Z) in the water tray (B) as shown.
- The water pump (L) is equipped with suction feet to secure in place. Press down firmly on the pump to attach the feet to the bottom of the water tray (B), which is marked "pump" (1).
- Connect the clear water tube (2) to the barbed end of the 90° fitting (3).
- NOTE:** Make sure the tube is placed under the sliding table frame before installing onto the pump fitting.
- Secure the water pump power cord (4) and clear water tube (2) by placing them into the two cord clamps (5) on the left side of the table frame and twisting the ends closed.
- Insert the water pump power cord plug (6) into the power cord receptacle (GG) as shown in Fig. 10. The water pump will start when the tile saw is turned on.

**NOTE:** Do not use pump when not submerged in water as it may damage the pump. If the pump does not push water out of the clear water tube onto the blade after starting the saw, unplug the saw from the electrical outlet, disconnect the clear water tube from the pump. Submerge the pump in water, reconnect the clear water tube to the pump, plug the saw back into the electrical outlet and start the saw to get the water flowing through the tube to the blade.

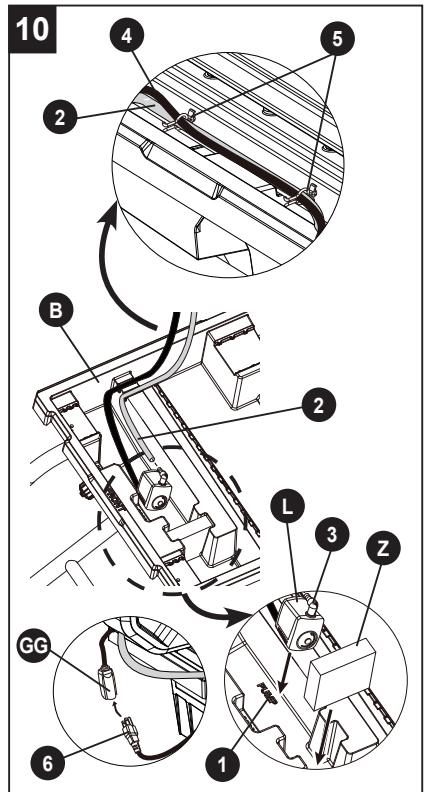

## INSTALLING/REMOVING THE REAR TABLE EXTENSION (FIG. 11) - BAG X

Move the sliding table to its most forward position and lock in place.

### To install the rear table extension:

- Insert the tab (1) on the front of the rear table extension (D) under the sliding table and insert the slot (2) on the front of the rear table extension (D) into the tab on the sliding table.
- Insert the side tab (3) on the left side of the rear table extension (D) into the slot (4).
- Align the hole (5) of the rear table extension (D) with the hole (6) on sliding table.
- Secure by threading the rear table extension lock knob (RR) through the washer (tt) into the hole (6) located on right side of table.

**NOTE:** Make sure that the table insert on the rear table extension is aligned with the table insert on the sliding table.

### To remove the rear table extension:

- Loosen the rear table extension lock knob (RR) and then remove the knob and the washer (tt).
- Pull the tab (3) out of the slot (4) and pull the tab (1) and slot (2) out of the sliding table, and then remove the the rear table extension (D).

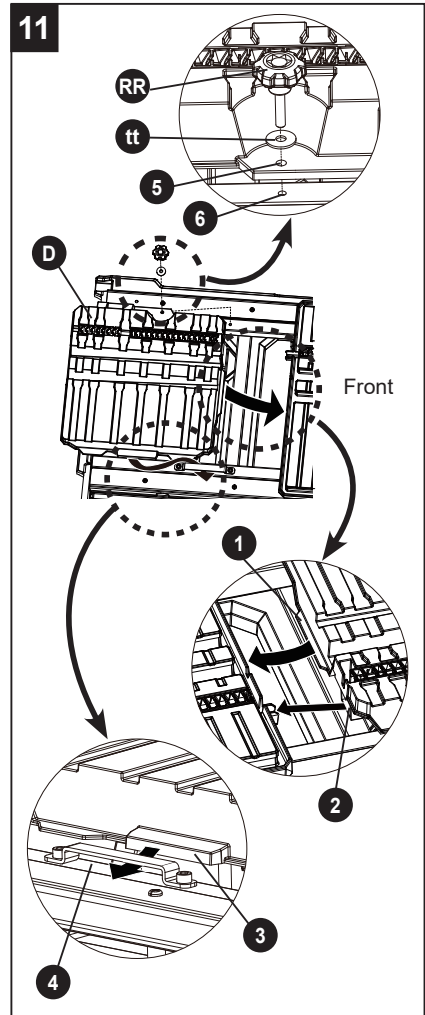

## RAISING AND LOWERING THE CUTTING HEAD ASSEMBLY (FIG. 12, 13)

### Raising the cutting head assembly (Fig. 12)

- Pull out the hold-down latch (SS).
- Grasp the motor handle (KK) to raise up the cutting head to a vertical position, and then release the hold-down latch (SS). Tighten the cutting head lock knob (MM).
- Pull out the arm folding lock knob (FF) and hold the motor handle (KK) to raise up the cutting head assembly. Push in the arm folding lock knob (FF) and rotate clockwise to tighten it.
- Install the rear table extension (D).

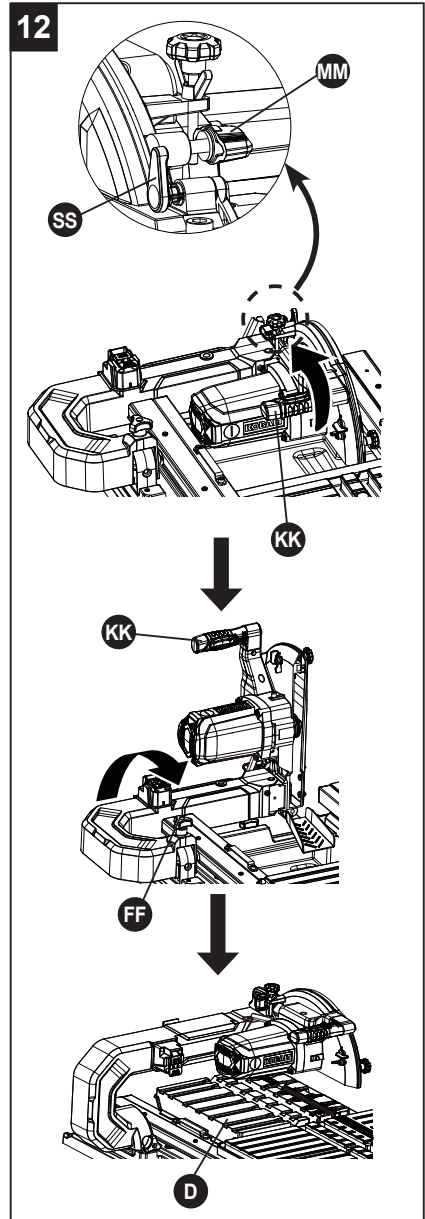

### Lowering the cutting head assembly (Fig. 13)

- Remove the rear table extension (D).
- Loosen the arm folding lock knob (FF) and pull it out.
- Grasp the motor handle (KK) to lower the cutting head assembly backward.
- Release the arm folding lock knob (FF) and it will lock into the hole automatically to lock the arm.
- Loosen the cutting head lock knob (MM) and pull out the hold-down latch (SS). Grasp the motor handle (KK) to lower the cutting head clockwise and then release the hold-down latch (SS) to put it into the locking hole.  
**NOTE:** When storing the saw, the cutting head assembly should always be folded.

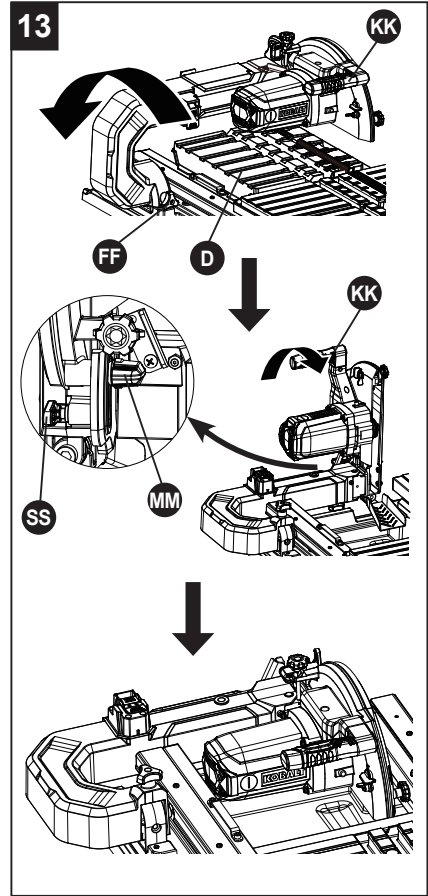

## INSTALLING THE SIDE SPLASH GUARD (FIG. 14)

- Place the side splash guard (K) over the rear guard.
- Insert the two holes on the outside of the side splash guard over the two screws (1) located on the side of the upper wheel guard (ZZ).

**NOTE:** It is not necessary to loosen or remove the screws (1) on the wheel guard to install the side splash guard.

- Loosen the wheel guard lock knob (YY) to open the upper wheel guard (ZZ). Place the hole on the inside of the side splash guard and insert onto the screw (2).

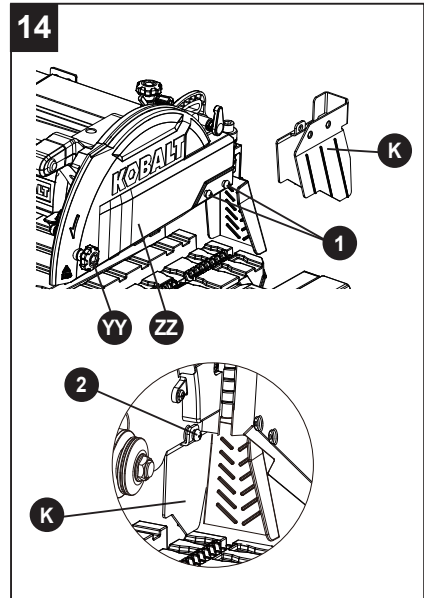

## INSTALLING THE CUTTING WHEEL

(FIG.15, 16, 17)

### ⚠ WARNING

- DO NOT use cutting wheels rated less than the no load speed of this tool. Failure to heed this warning could result in personal injury. DO NOT use a wheel with cracks, gaps, or teeth.
- A 10 in. tile saw wheel is the maximum wheel capacity of the saw. NEVER use a wheel that is too thick. Larger wheels will come in contact with the anti-splash guard, while thicker wheels will prevent the wheel bolt from securing the wheel on the arbor. Either of these situations could result in serious accidents and can cause serious personal injury.

- Disconnect the saw from the power source.
- Move the sliding table to the front of the saw.
- Loosen the cutting head lock knob (MM) and pull out the hold-down latch (SS) to raise the cutting head to its upmost position. Release the hold-down latch (SS) and tighten the cutting head lock knob (MM). (Fig. 15)
- Loosen the wheel guard lock knob (YY) to open the upper wheel guard (ZZ).
- Place the wheel wrench (OO) on the arbor nut (XX).
- Press the arbor lock button (Aa), holding it in firmly while turning the wheel wrench counterclockwise to loosen. (Fig. 16)
- Remove the arbor nut (XX) and outer flange (1). (Fig. 17)

**NOTICE:** Do not remove the inner flange (2).

- Place the 10 in. wheel (J) onto arbor. Make sure that the wheel's rotation arrow points in the same direction as the rotation arrow on the front of wheel guard.

**NOTICE:** The tile saw is equipped with two water nozzles (WW) to wet the wheel during operation. Make sure holes in nozzles face the wheel and that wheel is positioned between the two nozzles.

- Place outer flange (1) onto the arbor. The flats on the outer flange align with the flats on the arbor. Install with the cupped side of the outer flange facing the tile saw wheel.

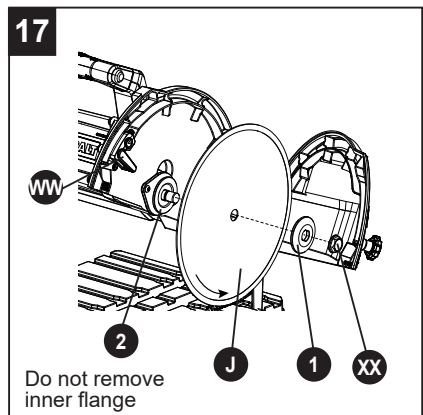
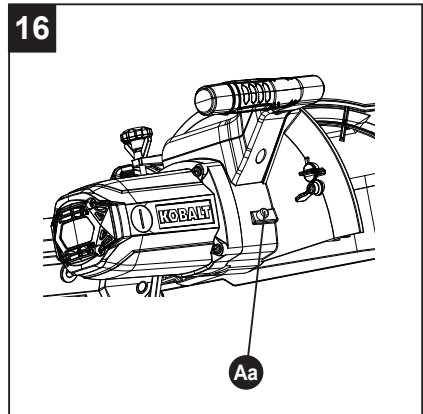
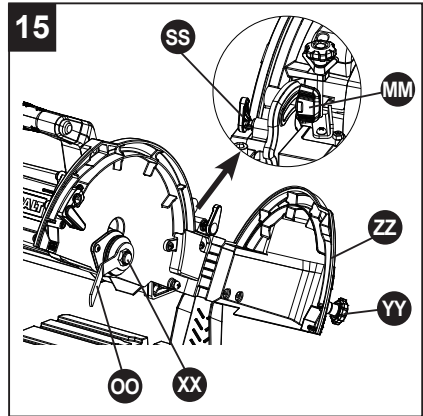

- Place arbor nut (XX) on arbor. Press and hold the arbor lock button (Aa-Fig. 16) in. Using the wheel wrench (OO) turning clockwise to tighten arbor nut (XX) securely. Release the arbor lock button. (Fig. 15)
- Close the upper wheel guard (ZZ) and tighten the wheel guard lock knob (YY).

### REMOVING THE CUTTING WHEEL (FIG. 15, 16, 17)

**⚠ WARNING:** To avoid injury from an accidental start, make sure the switch is in the OFF position and the plug is not connected to the power source outlet.

- Disconnect the saw from the power source.
- Move the sliding table to the front of the saw.
- Loosen the cutting head lock knob (MM) and pull out the hold-down latch (SS) to raise the cutting head to its upmost position. Release the hold-down latch (SS) and tighten the cutting head lock knob (MM). (Fig. 15)
- Loosen the wheel guard lock knob (YY) to open the upper wheel guard (ZZ).
- Place the wheel wrench (OO) on the arbor nut (XX).
- Press the arbor lock button (Aa), holding it in firmly while turning the wheel wrench counterclockwise to loosen. (Fig. 16)
- Remove the arbor nut (XX), outer flange (1) and cutting wheel (J). (Fig. 17)

**NOTE:** Do not remove the inner flange (2).

### WHEEL WRENCH STORAGE (FIG. 18)

For convenient storage and prevention of loss, there is a clip (NN) behind the arm (1) for storing the wheel wrench (OO) when not in use.

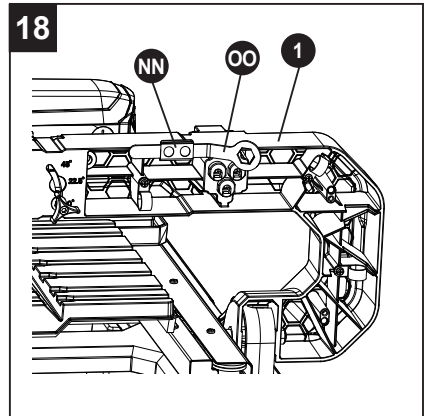

## INSTALLING AND REMOVING THE REAR WATER CATCH TRAY (FIG. 19)

### Installing the rear water catch tray

- Align four slots located on the rear left and right ends of the water pan with the arms of the rear water catch tray (F).
- Tilt the rear water catch tray (F) up slightly and then insert it into the slots of the water pan as shown in Fig. 19.

**NOTE:** Make sure that the rear water catch tray (F) is correctly installed before use as shown in Fig. 19-1.

- The small rear flap (II) is installed and folded over the rear water catch tray at the factory, and should be unfolded when in use.

### Removing the rear water catch tray

- Tilt the rear water catch tray (F) up slightly and then pull it out of the slots of the water pan.

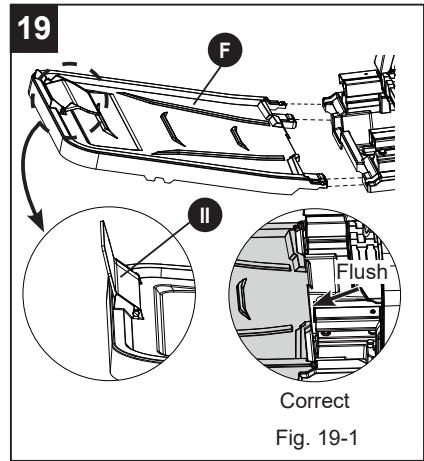

## INSTALLING THE SIDE TABLE EXTENSION (FIG. 20) - BAG X

- From the right side of the saw, align the pins (1) on the side table extension (E) with the holes of the sliding table (TT).
- Secure in place by turning the side table extension lock knob (UU) clockwise.

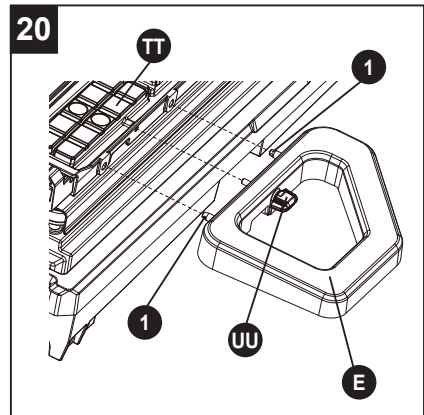

## INSTALLING THE SIDE WATER CATCH TRAY (FIG. 21)

- From the right side of the saw, slide the side water catch tray (G) into the three slots located on the sliding table (TT).

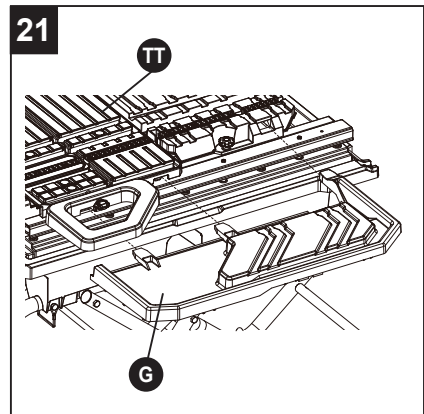

## CLOSING/EXTENDING THE STAND (FIG. 22, 23, 24, 25, 26)

- Remove water catch trays and any workpieces from the tool.
- Lower the wheel and secure by locking the cutting head in place using the cutting head lock knob (MM) and hold-down latch (SS). (Fig. 22)

### To close the stand (Fig. 22, 23):

- Step on the foot release lever (BB) and grasp left and right handles (O & P) simultaneously to lift them up and away from the body. (Fig. 22)
- Push the saw until the foot release lever (BB) clicks and locks into place. (Fig. 23)

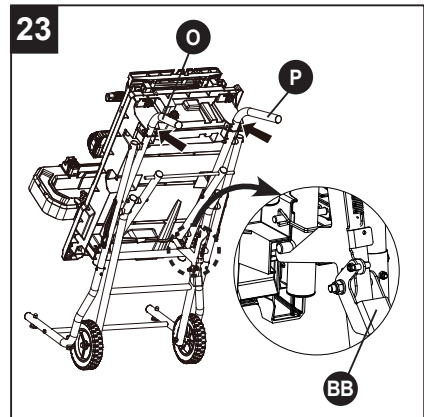
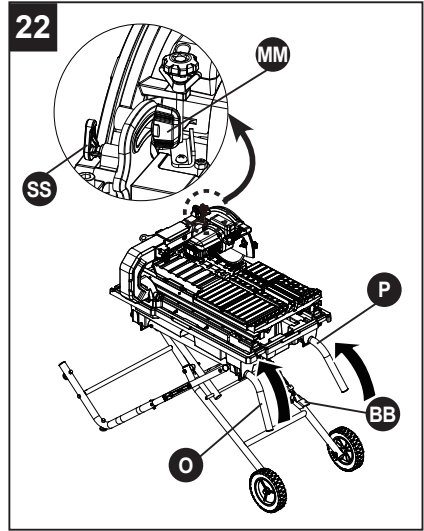

### To move the stand (Fig. 24):

- Holding the left and right handles (O & P) firmly, pull the handles toward you until the stand and saw are balanced on the wheels (CC).
- Push the saw to the desired location then either open the stand for saw operation or store the saw in a dry environment.

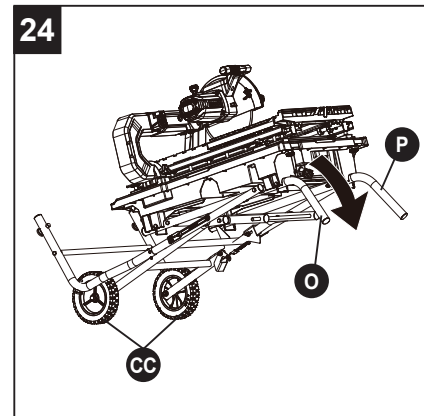

**To extend the stand (Fig. 25, 26):**

- Step on the release lever (1) and pull the left and right handles (O & P) toward you simultaneously. (Fig. 25)
- Once the stand is released from the foot release lever (BB), ease the stand toward the floor by pushing the handles toward the floor.
- With your hands on the left and right handles (O & P), push the stand towards the ground until the saw is in an extended position. (Fig. 26)

**NOTE:** The foot release lever will close over the pin locking the stand in an extended position.

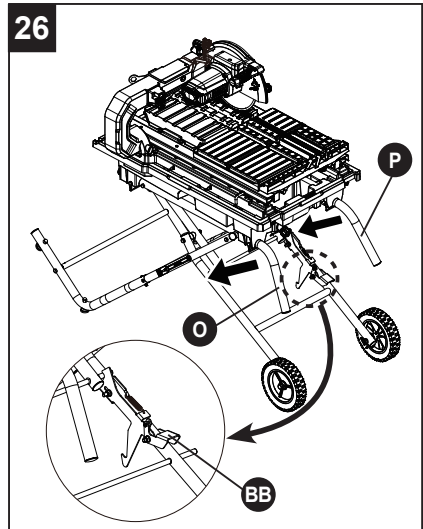
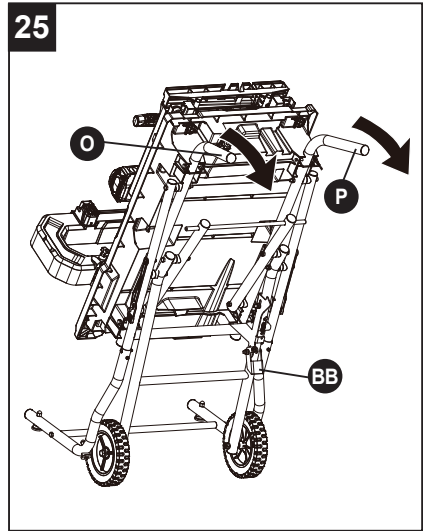

### SIDE WATER CATCH TRAY STORAGE (FIG. 27)

When the stand is folded, the side water catch tray (G) can be stored between the water tray and center brace.

**NOTE:** The bottom of the side water catch tray should be placed against the stop tab (1).

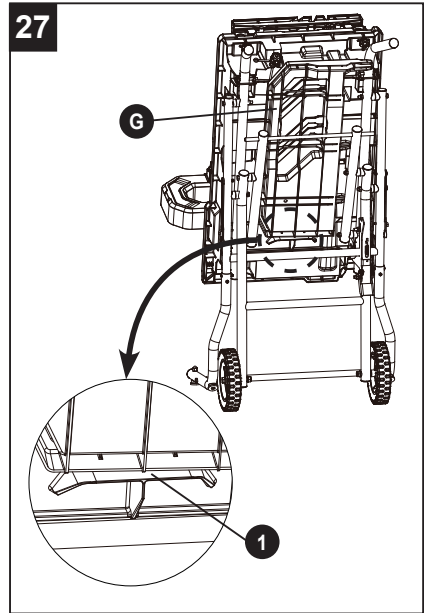

### REAR WATER CATCH TRAY STORAGE (FIG. 28)

When the stand is folded, the rear water catch tray (F) can be stored under the stand. Secure by buckling the hole of the rubber strip (1) on the screws (2) on both side of the rear water catch tray.

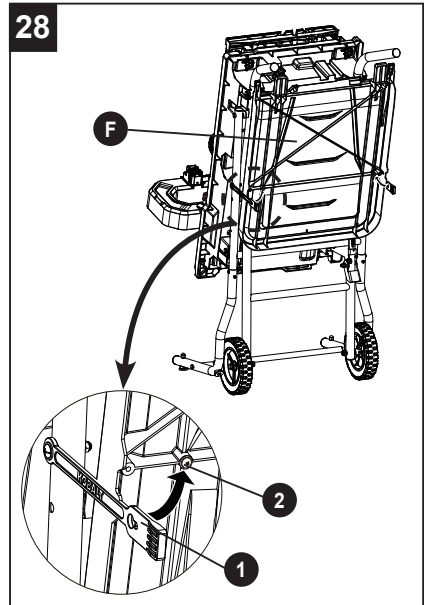

### INSTALLING THE RIP/ANGLE GUIDE (FIG. 29)

The Rip/Angle guide can be used from either the left or right side of the tile saw wheel.

- Place the slot underside of the Rip/Angle guide (H) on sliding T-fence extension (AA). Lock the Rip/Angle guide (H) securely to table by turning the lock knob (1) clockwise.

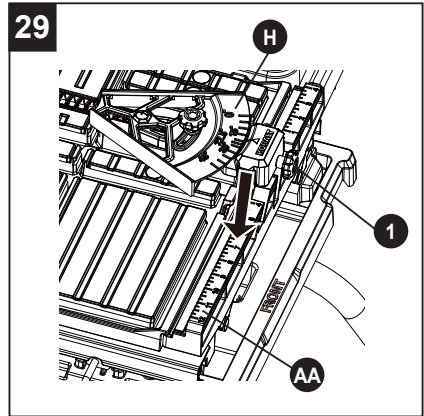

### INSTALLING THE TILE CLAMP (FIG. 30)

**NOTE:** The tile clamp is designed to be used for small or narrow pieces of tile. Use this clamp for all cuts that cannot be held firmly by the miter/angle guide and would require your hands to be closer than 3" from the cutting wheel. The sliding table has a channel for the tile clamp to be located into position and tighten.

- For tile 3" and less in width: Insert the tile clamp (I) into the T-shaped slot (1) from the right side of the sliding table (TT).

**NOTE:** Make sure the clamp will not contact the cutting wheel before starting the cut.

- For tile larger than 3" in width: Insert the tile clamp (I) into the T-shaped slot (1) from the left side of the sliding table (TT).

**NOTE:** Make sure the openings on the sliding table for the 22.5 and 45 bevel angles do not interfere with the tightening of the clamp.

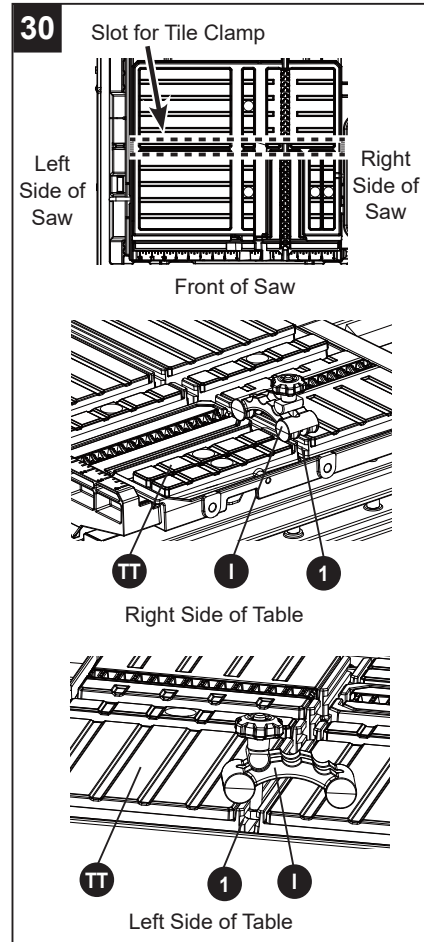

## ADJUSTMENT INSTRUCTIONS

**⚠ WARNING:** This saw was adjusted for accuracy at the factory. During shipping the components may have been moved out of alignment. In addition, usage and time will necessitate adjustments to be made.

**⚠ WARNING**

To prevent personal injury:

- Always disconnect plug from the power source when making any adjustments.
- This adjustment must be correct or accurate cuts can not be made. Also inaccurate adjustment can result serious personal injury.

### ADJUSTING THE FLOW OF WATER ON THE PUMP (FIG. 31)

- Fill the water pan with clean water as described below.
- Locate the “Max/Min” water flow selector (1) on the pump. For best performance, set the flow to “Max” to control the flow of water over the wheel.
- The pump turns on when the motor is turned on. Let the cutting wheel build up to full speed and wait for the wheel to get wet before moving the tile into the wheel.

**NOTE:** The flow of water can also be adjusted using the external water volume control. See page 37 for instructions.

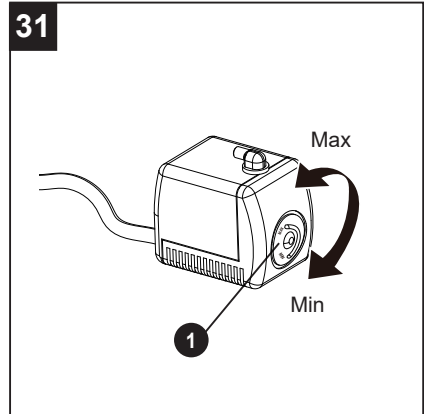

### SQUARING THE CUTTING WHEEL (FIG. 32, 33, 34)

#### Checking the cutting wheel alignment (Fig. 32)

- Place a 90° framing square (1) flat on the sliding table surface with one end against the sliding T-fence extension.
- Push the sliding table along the cutting wheel to determine if the groove along the 90° framing square is consistently flush against the wheel throughout the length of the stroke.
- If the groove is not consistent, see the next steps.

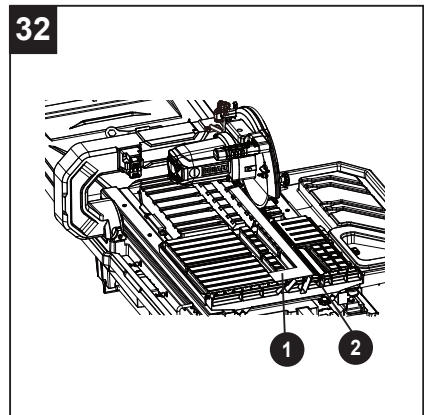

### Adjusting the cutting wheel 90° to sliding table (Fig. 32, 33)

- Disconnect the saw from the power source.
- Loosen the bevel lock knob (PP) and make sure the cutting wheel is in the maximum vertical position. Tighten the bevel lock knob (PP).
- Place a 90° framing square on the sliding table surface.
- If the cutting wheel is not 90° to the groove (2-Fig. 32), loosen the lock nut (3) with an adjustable wrench and turn the hex bolt (4) (located under the cutting arm assembly as shown in Fig. 33) in or out accordingly with a 3 mm hex key until the wheel is flush with the framing square while moving down the center of the groove. Tighten the lock nut (3).
- Make sure that the cutting wheel does not touch either side of the groove (2-Fig. 32) in the sliding table by pushing the table past the cutting wheel.

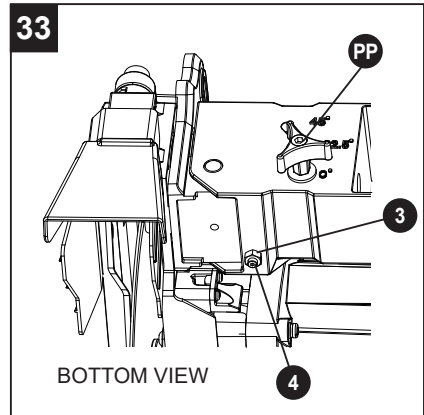

### Adjusting the cutting wheel 45° to sliding table (Fig. 34)

- Disconnect the saw from the power source.
- Loosen the bevel lock knob (PP) and move the cutting wheel to the maximum bevel position.
- Place the combination square to the sliding table surface.
- If the cutting wheel is not 45° to the groove (5), loosen the lock nut (6) with an adjustable wrench and turn the 45° hex bolt (7) (located on top of the cutting arm assembly as shown in Fig. 34) in or out accordingly by using a 3 mm hex key until it is 45° to the sliding table surface and tighten the bevel lock knob (PP). Tighten the lock nut (6).
- Make sure that the cutting wheel does not touch either side of the groove (5) in the sliding table by pushing the table past the cutting wheel.

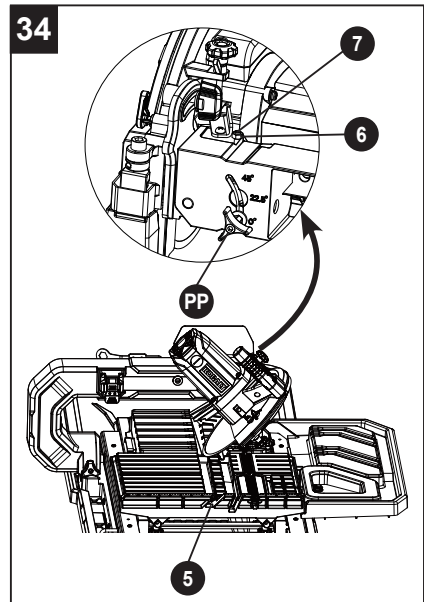

## CUTTING WHEEL DEPTH ADJUSTMENT

(FIG. 35)

**⚠ WARNING:** Improperly adjusting the cutting wheel depth could cause the cutting wheel to come in contact with the sliding table resulting in damage to the unit and/or possible serious injury.

The depth stop is factory set to provide maximum cutting capacity for the wheel provided with the saw. Make adjustments if desired.

### Adjusting the cutting depth

The depth of cut can be preset for even and repetitive shallow cuts.

- Disconnect the saw from the power source.
- To adjust the depth, loosen the cutting head lock knob (MM) and pull out the hold-down latch (SS). Grasp the motor handle (KK) to adjust the cutting head down until the cutting wheel is at the desired depth.
- While holding the cutting head in the desired position, loosen the wing nut (1) and turn the cutting depth stop knob (LL) until it touches the stop plate (2). Tighten the wing nut (1) and then release the hold-down latch (SS) and tighten the cutting head lock knob (MM).
- Recheck the cutting wheel depth by pushing the sliding table front to back past the cutting wheel and make sure the cutting wheel does not touch the grooves of the sliding table.

### Maximum cutting depth

The maximum depth travel of the cutting head was set at the factory.

- Disconnect the saw from the power source.
- Loosen the cutting head lock knob (MM) and pull out the hold-down latch (SS). Grasp the motor handle (KK) to adjust the cutting head to a 0° angle. Make sure the wheel sits in the groove in the sliding table.

**NOTICE:** Do not lock the cutting head lock knob while making this adjustment.

- After adjustment is complete, tighten the cutting head lock knob (MM).
- Recheck the cutting wheel depth by pushing the sliding table front to back.

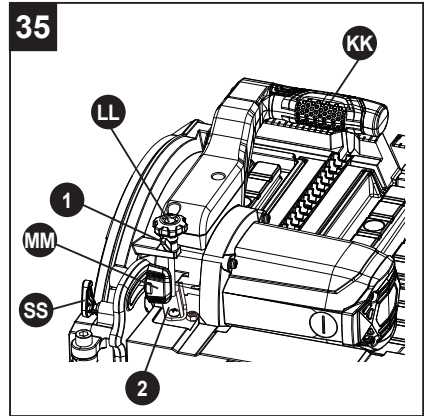

## OPERATING INSTRUCTIONS

### BEFORE USING THE TILE SAW

**⚠ WARNING:** To avoid mistakes that could cause serious, permanent injury, do not plug the tool in until the following steps are completed:

- Completely assemble and adjust the tile saw, following the instructions (SEE ASSEMBLY AND ADJUSTMENTS SECTIONS).
- Review the entire manual and understand all safety instructions and operating procedures in this Instruction Manual (SEE IMPORTANT SAFETY & OPERATIONS SECTIONS).
- To avoid injury or possible death from electrical shock, make sure your fingers do not touch the plug's metal prongs when plugging or unplugging your tile saw (SEE ELECTRICAL REQUIREMENTS AND IMPORTANT SAFETY SECTIONS).

### BASIC SAW OPERATIONS

#### **⚠ WARNING**

- Overfilling the water tray can lead to water entering the motor compartment and potential electric shock.
- When filling/draining water tray, make sure wet tile saw is unplugged from wall outlet.

#### LED LIGHT ON/OFF SWITCH (FIG. 36)

Turn the LED light on and off by pressing the LED light ON/OFF switch (VV) located on the side of the motor handle.

**NOTE:** The saw must be plugged in for the LED light to operate.

#### ON/OFF SWITCH (FIG. 36)

The ON/OFF switch has a removable safety key (Dd). With the key removed from the switch, unauthorized and hazardous use by children and others is minimized and the saw will not turn on.

- To turn the saw "ON", insert the safety key (Dd) into the slot of the ON/OFF switch (HH), and move the switch upward to the "ON" position.
- To turn the saw "OFF", move the ON/OFF switch (HH) downward.
- To lock the switch in the OFF position, grasp the sides of the safety key (Dd), and pull it out.
- With the switch key removed, the switch will not operate to power the saw on.

**⚠ WARNING:** ALWAYS lock the switch "OFF" when the tile saw is not in use. Remove the key and keep it in a safe place. In the event of a power failure, blown fuse, or tripped circuit breaker, turn the switch "OFF" and remove the key, preventing an accidental startup when power comes on.

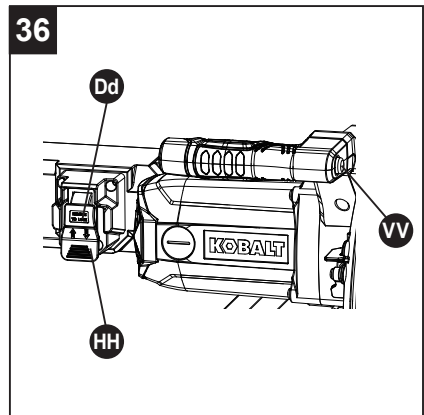

### USING THE RIP/ANGLE GUIDE (FIG. 37)

This guide can be placed on either side of the cutting wheel.

- Loosen the lock knob (1) to move the guide along the front rail to the desired position and tighten the lock knob (1).
- Loosen the Rip/Angle guide adjust lock knob (2) to turn the guide to the desired angle along the arc slot (3) and then tighten the Rip/Angle guide adjust lock knob (2).

**NOTE:** Please make sure the cutting wheel will not make contact with this guide during the cutting operation.

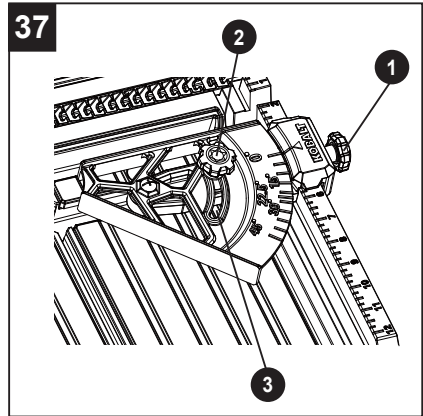

### FILLING/CHANGING THE WATER RESERVOIR (FIG. 38)

**⚠ WARNING:** When filling/draining water tray, make sure wet tile saw is unplugged from wall outlet.

#### To fill the reservoir with water

- Make sure the drain plug (DD) on the water tray is tight.
- Fill the water tray (B) with clean water. Ensure the water level is between "MAX" (1) and "MIN" (2) fill lines. Do not overfill.

#### To change the reservoir water

- Disconnect the saw from the power source.
- Place a bucket under the drain plug (DD).
- Remove the drain plug (DD) and empty waste water into a bucket. Do not allow the water to splash onto the ground or around the saw.
- Rinse the water reservoir thoroughly.
- Discard the waste water in accordance with local regulations.
- Replace the drain plug (DD) and refill water tray with clean water.

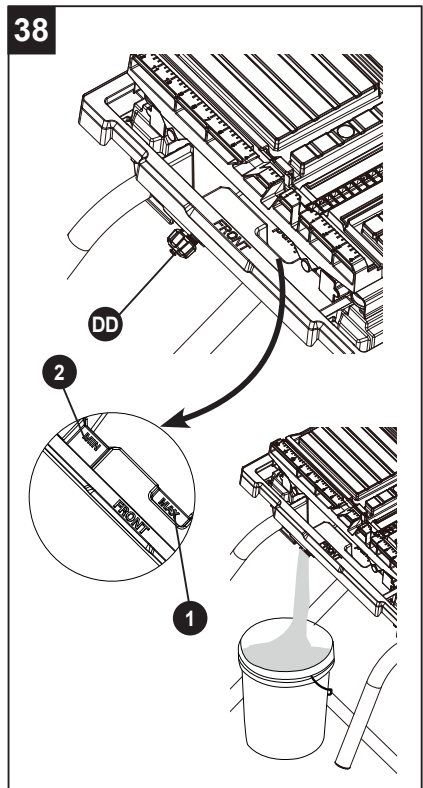

### EXTERNAL WATER CONTROLS (FIG. 39)

Water nozzles are adjustable to provide maximum water for cutting and change water spray direction.

- The water volume control (Cc) allows easy adjustment of nozzles (WW) to provide water volume. To provide maximum water volume, turn the water volume control (Cc) clockwise. To provide minimum water volume, turn the water water volume control (Cc) counterclockwise.
- The water angle control (Bb) allows easy adjustment of nozzles (WW) to desired angle.

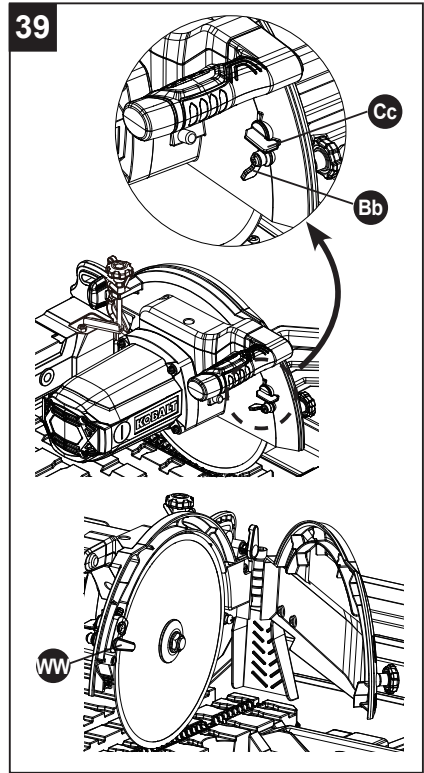

### LOCKING AND UNLOCKING THE SLIDING TABLE (FIG. 40)

#### To unlock the sliding table

- Pull the frame locking lever (EE) out and turn 90° counterclockwise to the “unlocked position” to unlock the sliding table.

#### To lock the sliding table

- Pull the frame locking lever (EE) out and turn 90° clockwise to the “locked position”.
- Release the lever.

**NOTE:** When you push the sliding table, it will “click” into place. This is the frame locking lever snapping into a hole in the sliding table locking it in place.

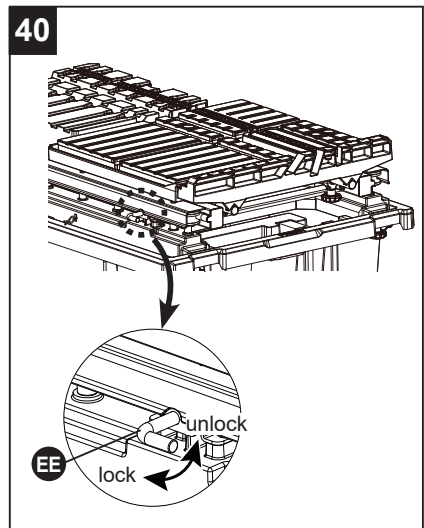

### LOCKING AND UNLOCKING THE SLIDING T-FENCE EXTENSION (FIG. 41)

- Lock the sliding table (TT).
- Loosen the two sliding T-fence extension lock knobs (Ee) to unlock the sliding T-fence extension (AA).
- To lock the sliding fence (AA), tighten two sliding T-fence lock knobs (Ee).

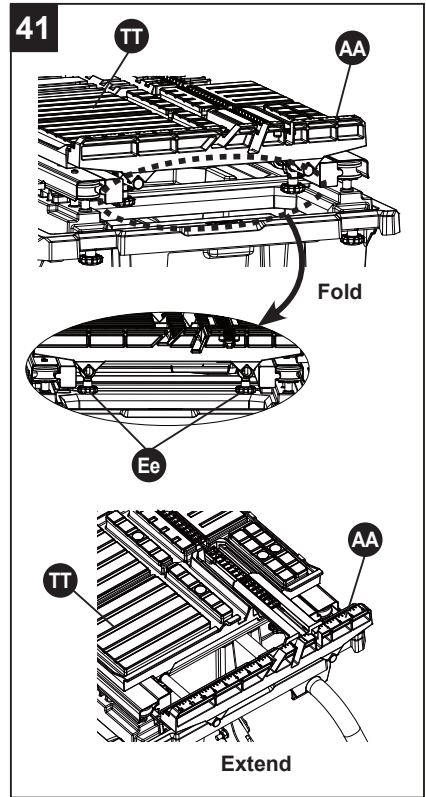

## CUTTING OPERATION

**⚠ WARNING:** Before making any adjustments or removing or installing attachments or accessories, make sure the switch is in the OFF position to avoid injury from an accidental start.

Before turning the tile saw on, verify the alignment of the sliding table and the cutting wheel. Always center the cutting wheel in one of the sliding table grooves before cutting. Make sure the cutting wheel does not contact the tile or table before turning saw on.

### STRAIGHT CUT (FIG. 42)

- Fill the water tray with clean water.
- Using a pencil or marker mark the area to be cut on tile.
- Loosen the lock knob (1) and move the Rip/Angle guide (H) to the desired position. Tighten the lock knob (1).
- Place the tile on the sliding table and firmly against the Rip/Angle guide (H) and sliding T-fence extension (AA).
- Pull the ON/OFF switch (HH) upward to turn on the tile saw. Allow the cutting wheel to reach full speed and wait until the stream of water from the water nozzle completely covers the cutting wheel.
- Using both hands to slowly push the sliding table assembly toward the cutting wheel to feed the tile into the cutting wheel (Never force the material through the wheel. Move at a slow consistent pace.).
- Turn the tile saw off once cut is performed.

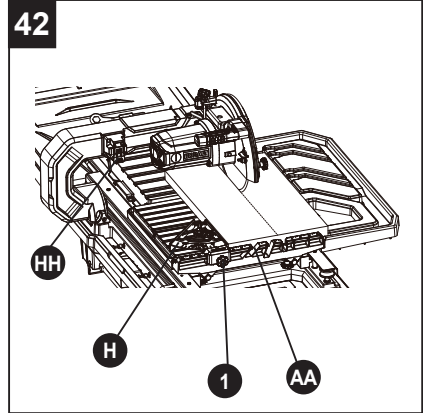

### CUTTING LONG TILE (UP TO 40") (FIG. 43)

- Move the sliding table to the front of the saw.
- Loosen the two sliding T-fence extension lock knobs (Ee) and pull the sliding T-fence extension to the front position.  
**NOTE:** Do not lock the sliding T-fence extension lock knobs.
- Using a pencil or marker mark the area to be cut on tile.
- Place up to 40" tile on the sliding table and against the sliding T-fence extension.
- Pull the ON/OFF switch (HH) upward to turn on the tile saw. Allow the cutting wheel to reach full speed and wait until the stream of water from the water nozzle completely covers the cutting wheel.
- Using both hands to slowly push the sliding table toward the cutting wheel. As the cutting proceeds, simultaneously push the sliding T-fence extension forward to feed the tile into the cutting wheel (Never force the material through the wheel. Move at a slow consistent pace).
- Turn the tile saw off once cut is performed.

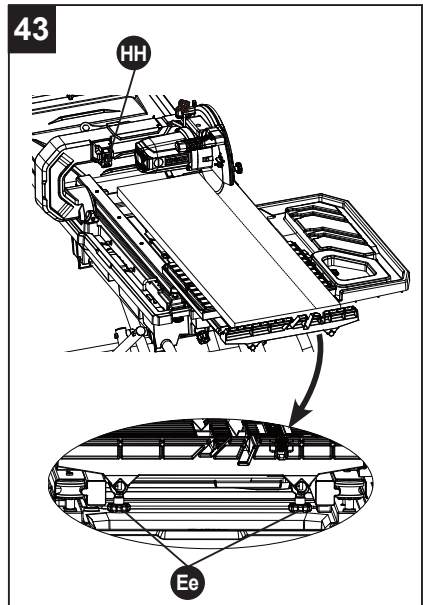

**NOTE:** For cutting small/narrow tile, see the section of "INSTALLING THE TILE CLAMP" on page 31.

## DIAGONAL CUT (FIG. 44)

**NOTE:** Diagonal cuts are also referred to as “long point to point cuts.”

- Fill the water tray with clean water.
- Using a pencil or marker mark the area to be cut on tile.
- Align one point of the tile against the cut indicator (1) of the sliding table. The cut indicator means the exact location where the cutting wheel will pass through the sliding table.
- Align the front of the tile to the cutting wheel and hold against the Rip/Angle guide (H), which should be adjusted to proper angle.
- Pull the ON/OFF switch (HH) upward to turn the tile saw on to allow the cutting wheel at the full speed and wait until the stream of water from the water nozzle completely cover the cutting wheel.
- Using both hands to slowly push the sliding table toward the cutting wheel to feed the tile into the cutting wheel.
- Turn the tile saw off once cut is performed.

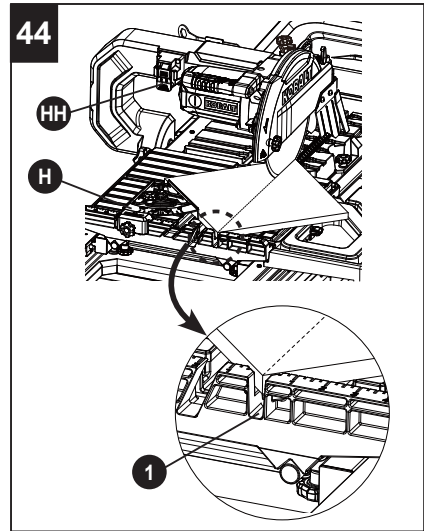

## BEVEL CUT (FIG. 45)

**NOTE:** Bevel cuts can be made at 22.5 and 45 angles.

- Fill the water tray with clean water.
- Using a pencil or marker marks the area to be cut on tile.
- Loosen the cutting head lock knob (MM) and pull out the hold-down latch (SS) to raise the cutting head up. And then tighten the cutting head lock knob (MM).
- Loosen the bevel lock knob (PP) to tilt the cutting head to 22.5° or 45° clockwise. Tighten the bevel lock knob (PP).
- Loosen the cutting head lock knob (MM) to lower the cutting head in one of the two miter slots in the table. Tighten the cutting head lock knob (MM).
- **NOTICE:** Check to insure the cutting wheel does not contact the table before turning the saw on.
- Pull the ON/OFF switch (HH) upward to turn the tile saw on to allow the cutting wheel at the full speed and wait until the stream of water from the water nozzle completely cover the cutting wheel.
- Using both hands to slowly push the sliding table toward the cutting wheel to feed the tile into the cutting wheel.
- Turn the tile saw off once cut is performed.

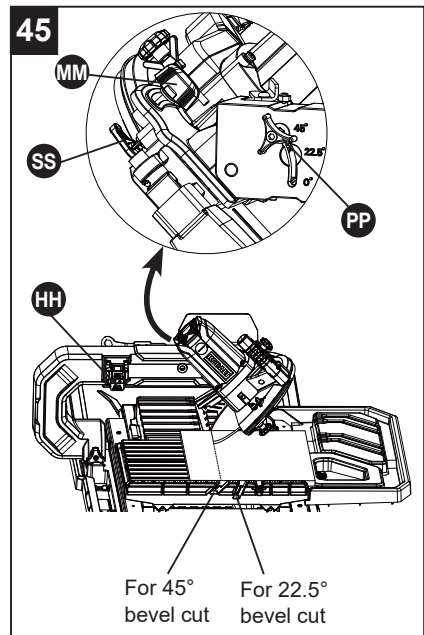

## MITER CUT (FIG. 46)

**NOTE:** Miter cuts are used for cutting outside and inside corners on material, decorative chair rail and base moulding with the material at any angle to the cutting wheel other than 90°.

- Fill the water tray with clean water.
- Using a pencil or marker, mark the area to be cut on tile.
- Loosen the lock knob (1) to move the Rip/ Angle guide along the front rail to the desired position and then tighten the lock knob (1).
- Loosen the Rip/Angle guide adjust lock knob (2) to turn the guide to the desired angle along the arc slot and then tighten the Rip/Angle guide adjust lock knob (2).
- Pull the ON/OFF switch (HH) upward to turn the tile saw on to allow the cutting wheel at the full speed and wait until the stream of water from the water nozzle completely cover the cutting wheel.
- Using both hands to slowly push the sliding table toward the cutting wheel to feed the tile into the cutting wheel.
- Turn the tile saw off once cut is performed.

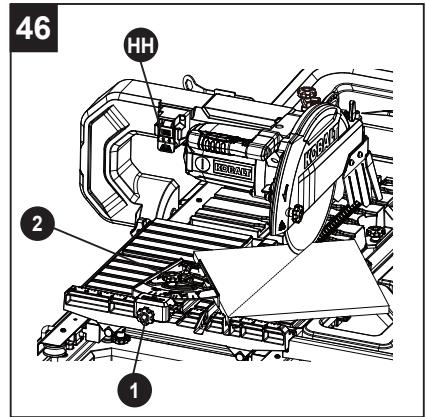

## PLUNGE CUT (FIG. 47)

**NOTE:** Plunge cuts mean to position the tile under the cutting wheel directly and lower the cutting head to make cuts onto the interior of the tile, such as electrical outlets or air conditioner registers.

- Fill the water reservoir with clean water.
- Using a pencil or marker, mark the area to be cut on tile.
- Loosen the cutting head lock knob (MM) and pull out the hold-down latch (SS) to raise the cutting head upward to the maximum height.
- Pull the ON/OFF switch (HH) upward to turn the tile saw on to allow the cutting wheel at the full speed and wait until the stream of water from the water nozzle completely cover the cutting wheel.
- Hold the cutting head firmly by the motor handle (KK).
- Move the tile on the sliding table underneath the cutting wheel.
- Slowly lower the cutting head to make a cut on the tile. And then raise the cutting head.
- Turn the tile saw off once cut is performed.
- Withdraw the sliding table from the cutting head and then adjust the tile position for the next cut.

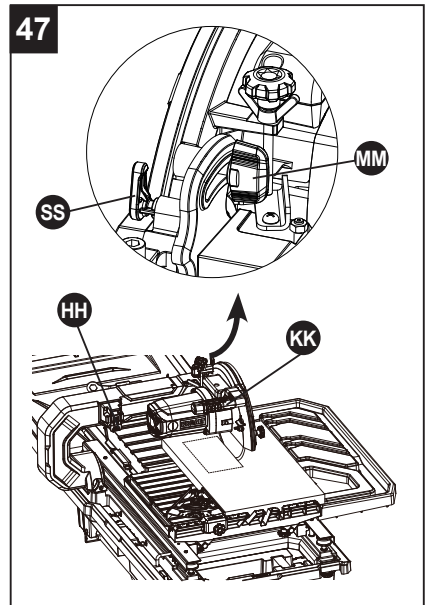

## CARE AND MAINTENANCE

**⚠ WARNING:** Do not service, clean or maintain the saw without first turning off the motor and unplugging the saw from the power source. Failure to do so may result in serious personal injury.

### REPLACING CARBON BRUSHES (FIG. 48)

**NOTICE:** Replace both carbon brushes when either has less than 1/4 in. length of carbon remaining, or if the spring or wire is damaged or burned.

- To inspect or replace brushes, first unplug the saw.
- Loosen the cutting head lock knob (MM) and pull out the hold-down latch (SS) to raise the cutting head at the maximum height. Release the hold-down latch (SS) and tighten the cutting head lock knob (MM).
- Loosen the bevel lock knob (PP) to tilt the cutting head at 45° clockwise. Tighten the bevel lock knob (PP).
- Remove the black plastic cap (1) on the side of the motor. Remove the cap cautiously, because it is springloaded. Pull out the carbon brush (Ff) and replace.
- The ears on the metal end of the assembly go in the same hole the carbon part fits into. Tighten the cap snugly, but do not overtighten.
- Repeat for the carbon brush located on the other side of motor.

**NOTICE:** To reinstall the same brushes, first make sure the brushes go back in the way they came out. This will avoid a break-in period that reduces motor performance and increases wear.

### CLEANING

- Insert the water pump into a bucket with clean water and pump the water through the clear water tube allowing the tube to be cleaned.
- Turn off and unplug the saw from the power source.
- Place a bucket under the drain plug. Remove the drain plug and allow the water to empty into the bucket.
- Slide the edge guide off the rail system. Spray the Rip/Angle guide with a hose or wipe with a grout sponge or clean cloth.
- Wipe the sliding table, motor housing, and motor support arm with a grout sponge or clean cloth. Spray lubricants are not required on the rail or cutting wheel.
- Remove all water catch trays and clean the water trays by spraying with a hose or wiping with a grout sponge.

Use clean cloth to remove dirt, dust, oil, grease, etc. Do not use gasoline, turpentine, lacquer or paint thinner, dry cleaning fluids or similar products. Chemicals can damage, weaken or destroy plastic which may result in personal injury.

Try not to let any liquid get inside the motor; never immerse any part of the tool into a liquid.

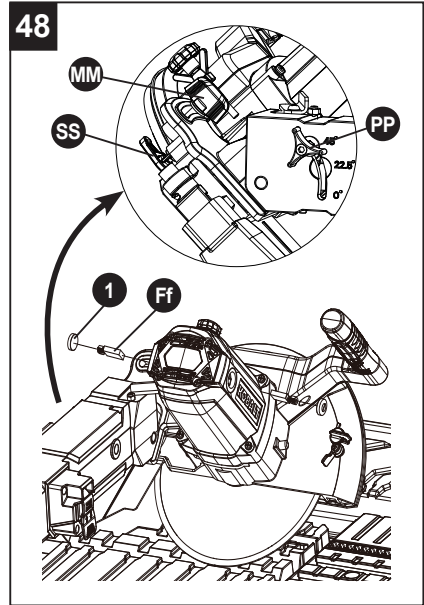

### CLEANING THE PUMP (FIG. 49)

For best performance, the pump may be cleaned periodically.

- Unplug pump before handling or cleaning the pump.
- Pull out to remove the front cover (1).
- Using a small brush and/or water, clean any debris or trash that is trapped on the inside of the pump.
- Replace the front cover (1).

**NOTE:** To maintain efficiency and extend the life of the pump, check intake screen before use to make sure it is clean.

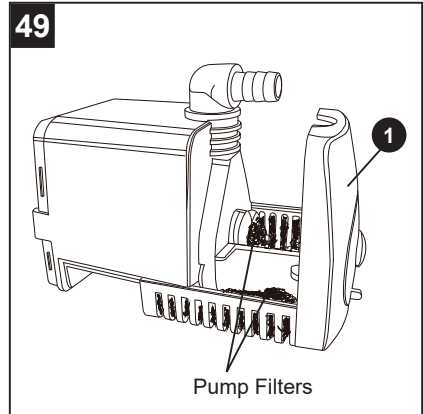

### CLEANING THE FILTER

For best performance, the filter should be cleaned periodically.

- Remove the filter from the water tray and using a water hose run clean water thru the filter on both sides to remove any debris on the filter's surface.
- Place filter back into the water tray.

## FREE WARNING LABEL REPLACEMENT:

If your warning labels become illegible or are missing, call 803-980-7740 for a free replacement.

### **⚠ WARNING**

**DO NOT replace the power cord.** If you have any problem or questions concerning the power cord, call the Customer Service Department at 888-356-2258.

<b>KOBALT</b>		#5202571
10-IN FOLDING WET TILE SAW WITH STAND 25,4-CM SIERRA PARA AZULEJOS DE CORTE EN HÚMEDO PLEGABLE CON SOPORTE		888-356-2258 (888-3KOBALT) DISTRIBUTED BY/DISTRIBUIDO POR: LOWE'S HOME CENTERS LLC 1000 LOWE'S BLVD. MOORESVILLE, NC 28117
BLADE/HOJA 15A, 4,000min <sup>1</sup> (RPM) [NO LOAD] 120V a.c. 60Hz 15 AMPERIOS, 4000 RPM (SIN CARGA) 120 V AC.- 60 HZ		  
SERIAL NO.: SERIE NO.:	MFG. DATE: FECHA DE FABRICACIÓN:	
REXON INDUSTRIAL CORP., LTD. 261, JEN HWA ROAD, TALI, TAICHUNG, TAIWAN		
MADE IN TAIWAN/HECHO EN TAIWÁN		

JP-900N Submersible Pump AC, 120 V, 0.5A, 60 Hz Impedance protected Acceptable for indoor and outdoor use E284083	
<b>⚠ WARNING</b> To reduce the risk of injury, the user must read and understand operator's manual. To reduce the risk of electric shock, connect only to a properly grounded, grounding type receptacle. To reduce the risk of electric shock, install only on a circuit protected by a ground-fault circuit-interrupter (GFCI). Risk of electric shock - This pump has not been investigated for use in swimming pools or marine areas. * This pump has been evaluated for use with water only. * DO NOT RUN DRY.	

<b>⚠ ADVERTENCIA</b>
<ul style="list-style-type: none"><li>• Para reducir el riesgo de lesiones, el usuario debe leer y comprender el manual del operador.</li><li>• Para reducir el riesgo de descarga eléctrica, conecte solo a un receptáculo con conexión a tierra correctamente puesto a tierra.</li><li>• Para reducir el riesgo de descarga eléctrica, instale sólo en un circuito protegido con un interruptor de circuito con pérdida a tierra (GFCI).</li><li>• Riesgo de descarga eléctrica: no se ha investigado el uso de esta bomba en piscinas o áreas navales.</li><li>• Esta bomba ha sido evaluada para su uso con agua únicamente.</li><li>• NO DEJE FUNCIONE EN SECO.</li></ul>

<b>⚠ DANGER</b>
To reduce the risk of electrocution, always power the saw with a GFCI protected outlet.

<b>⚠ PELIGRO</b>
Para reducir el riesgo de electrocución, siempre conecte la sierra a una toma de corriente con protección GFCI.

<b>⚠ WARNING</b>	<b>⚠ ADVERTENCIA</b>
FOR YOUR OWN SAFETY READ INSTRUCTION MANUAL BEFORE OPERATING SAW. Wear eye protection. Disconnect saw before servicing, when changing cutting wheels, and cleaning. Use tool only with smooth edge cutting wheels free of openings and grooves. Replace damaged cutting wheel before operating. Do not fill water bath above max fill line. Never operate the tool without the wheel guard securely closed. Use splash hood for every operation for which it can be used. DO NOT EXPOSE TO RAIN OR USE IN DAMP LOCATIONS.	
PARA SU PROPIA SEGURIDAD, LEA EL MANUAL DE INSTRUCCIONES ANTES DE OPERAR LA SIERRA. Use ojo protección. Desconecte la sierra antes de realizar el mantenimiento, cuando cambia las ruedas de corte y limpie. Utilizar Herramienta Únicamente con discos de corte de borde liso, sin aberturas ni ranuras. Reemplazar dañado Rueda de corte antes de operar. No llene el baño de agua por encima de la línea de llenado máximo. Nunca opere el Herramienta sin el protector de rueda bien cerrado. Utilice una capucha contra salpicaduras para cada operación para la cual puede ser usado. NO LO EXPONGA A LA LLUVIA NI LA UTILIZACIÓN EN UBICACIONES DE BAÑO.	

<b>⚠ WARNING</b>	<b>⚠ ADVERTENCIA</b>
To reduce the risk of injury, lock working table before transport.	
Para disminuir el riesgo de lesiones, seguro de la mesa para fijar antes de transportar.	

<b>⚠ WARNING</b>	<b>⚠ ADVERTENCIA</b>
Receptacle is for water pump only, 125V 0.5A MAX.	El receptáculo es solamente para la bomba de agua, 125V, 0,5A MÁX.



## TROUBLESHOOTING

### WARNING

Do not service, clean or maintain the saw without first turning off the motor and unplugging the saw from the power source. Failure to do so may result in serious personal injury.

PROBLEM	POSSIBLE CAUSE	CORRECTIVE ACTION
Motor does not start.	<ol style="list-style-type: none"><li>1. Power cord is not plugged into the outlet.</li><li>2. Switch failure.</li><li>3. Brush worn.</li><li>4. Fuse blown or circuit breaker tripped on home panel.</li></ol>	<ol style="list-style-type: none"><li>1. Plug in properly.</li><li>2. Replace switch.</li><li>3. Replace brushes. See MAINTENANCE section.</li><li>4. Verify there is electrical power at the outlet.</li></ol>
Saw is overheating.	<ol style="list-style-type: none"><li>1. The saw continues to operate too long under pressure.</li><li>2. Blockage or dirt jams the ventilation slots of the motor.</li></ol>	<ol style="list-style-type: none"><li>1. Turn the saw off and let it rest until the motor is cool to touch.</li><li>2. Check and clean the ventilation slots of the motor, removing blockage or dirt.</li></ol>
Brush spark when switch released.	<ol style="list-style-type: none"><li>1. Brush worn.</li></ol>	<ol style="list-style-type: none"><li>1. Replace brushes. See MAINTENANCE section.</li></ol>
The pump is not flowing water.	<ol style="list-style-type: none"><li>1. Water amount is not enough.</li><li>2. Water tube is jammed by dirt.</li></ol>	<ol style="list-style-type: none"><li>1. Add water until the pump is submerged completely.</li><li>2. Clean the water tube, filter and pump filter.</li></ol>
Sliding table is not sliding smoothly.	<ol style="list-style-type: none"><li>1. Dirt or tile dust is jammed too much on the guide rails or sliding table rollers.</li></ol>	<ol style="list-style-type: none"><li>1. Clean the dirt.</li></ol>
Saw vibrates or shakes.	<ol style="list-style-type: none"><li>1. Saw wheel not round / damaged / loose.</li><li>2. Wheel not tightened on saw, arbor nut loose.</li></ol>	<ol style="list-style-type: none"><li>1. Replace wheel.</li><li>2. Tighten arbor nut.</li></ol>

## REPLACEMENT PARTS LIST

For replacement parts, call our customer service department at 888-3KOBALT (888-356-2258), 8 a.m. - 8 p.m., EST, Monday - Sunday. You could also contact us at [partsplus@lowes.com](mailto:partsplus@lowes.com).

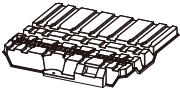

D

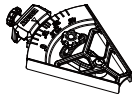

H

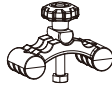

I

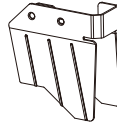

K

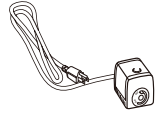

L



Z



bb



ee



ss

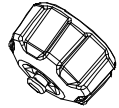

DD

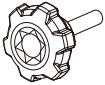

JJ

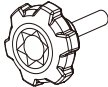

LL



MM

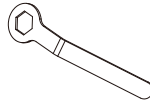

OO

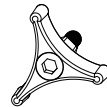

PP

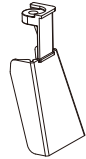

QQ

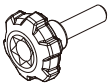

RR



Dd



Ee

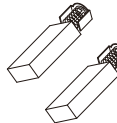

Ff



Gg



Hh

PART	DESCRIPTION	PART#
D	Rear table extension	530N
H	Rip/Angle guide	50L6
I	Tile clamp	50KG
K	Side splash guard	507Q
L	Water pump	528E
Z	Filter	50KW
bb	Spacers (set of 2)	2FUD
ee	Foot pad	2FUH
ss	Hitch pin	50KV
DD	Drain plug	530P
JJ	Water tray lock knob	50P2
LL	Cutting depth stop knob	50K5
MM	Cutting head lock knob	52X3
OO	Wheel wrench	3ZYE
PP	Bevel lock knob	53KY
QQ	Rear splash guard	507P
RR	Rear table extension lock knob	505H
Dd	Safety key	2X21
Ee	Sliding T-fence extension lock knob	505H
Ff	Carbon brushes (set of 2)	0QQT
Gg	10 mm Hex wrench	531S
Hh	Manual	52ZD

DISTRIBUTED BY:  
**Lowe's Home Centers LLC**  
1000 Lowe's Blvd., Mooresville, NC 28117

## **WARRANTY**

---

The manufacturer will offer replacement parts for this product which under normal usage have proven to be defective in their manufacture or workmanship for a period of THREE (3) years from the date of initial retail purchase. This warranty is valid only to the original purchaser. This warranty is not transferable and does not cover any parts that have been subjected to misuse, abuse, alteration, overload, accident or normal wear of moving parts. Tools that have been sold "as is," sold reconditioned or used as rental equipment are not covered.

Warranty replacement parts can be obtained by contacting the manufacturer at 888-3KOBALT. Only the manufacturer is authorized to perform warranty service on this product. This warranty does not apply to accessories or damage caused where repairs have been made or attempted by others.

The manufacturer is not responsible for direct, indirect, incidental or consequential damages. Some states do not allow limitations on how long an implied warranty lasts and/or do not allow the exclusion or limitation of incidental damages, so the above limitations may not apply to you. This warranty gives you specific legal rights, and you may also have other rights, which vary from state to state.

The manufacturer makes no warranties, representations or promises as to the quality of its power tools other than those specially stated in this warranty.

### **WARRANTY VOID IF PRODUCT USED FOR COMMERCIAL PURPOSES.**

For replacement parts, call our customer service department at 888-3KOBALT (888-356-2258).