



SINGLE-ZONE
LGRED^o
FOUR-WAY
CEILING-CASSETTE SYSTEM
ENGINEERING MANUAL

Single-Zone Four-Way
Ceiling-Cassette
Heat Pump Systems
1.5 to 4 Tons



LC188HHV4 (18,000 Btu/h)

LC249HHV (24,000 Btu/h)

LC369HHV (36,000 Btu/h)
LC429HHV (42,000 Btu/h)
LC489HHV (48,000 Btu/h)

PROPRIETARY DATA NOTICE

**This document, as well as all reports, illustrations, data, information, and other materials are the property of LG Electronics U.S.A., Inc., and are disclosed by LG Electronics U.S.A., Inc. only in confidence.
This document is for design purposes only.**

A summary list of safety precautions is on page 3.

For more technical materials such as submittals, catalogs, installation, best practices, building ventilation, owner's, and service manuals, visit www.lghvac.com.





For continual product development, LG Electronics U.S.A., Inc., reserves the right to change specifications without notice.

© LG Electronics U.S.A., Inc.



Unit Nomenclature.....	4
LG Air Conditioner Technical Solution (LATS)	5-6
LGRED° Four-Way Ceiling-Cassette Product Data	7-41
Mechanical Specifications	8-9
General Data	10-12
Electrical Data	13
Functions, Controls, and Options	14
Outdoor Unit Dimensions	15-16
Outdoor Unit Center of Gravity / Corner Weights	17
Indoor Unit Dimensions	18-20
Acoustic Data	21-24
Refrigerant Flow Diagrams.....	25-29
Wiring Diagrams.....	30-34
Electrical Connections.....	35-37
Air Velocity and Temperature Distribution.....	38-39
Accessories	40-41
LGRED° Four-Way Ceiling-Cassette Performance Data.....	42-60
Cooling Capacity	43-47
Maximum Cooling Capacity.....	48-52
Heating Capacity	53-55
Maximum Heating Capacity.....	56-58
Equipment Selection Procedure.....	59-60
Placement Considerations	61-73
Indoor Unit.....	62-63
Outdoor Unit.....	64-69
Installing Outdoor Units Indoors.....	70-72
Refrigerant Piping Design.....	73

TABLE OF SYMBOLS

 DANGER	<i>This symbol indicates an imminently hazardous situation which, if not avoided, will result in death or serious injury.</i>
 WARNING	<i>This symbol indicates a potentially hazardous situation which, if not avoided, could result in death or serious injury.</i>
 CAUTION	<i>This symbol indicates a potentially hazardous situation which, if not avoided, will result in minor or moderate injury.</i>
Note:	<i>This symbol indicates situations that will result in equipment or property damage accidents only.</i>
	<i>This symbol indicates an action that should not be performed.</i>



Single-Zone Indoor Units and Outdoor Units

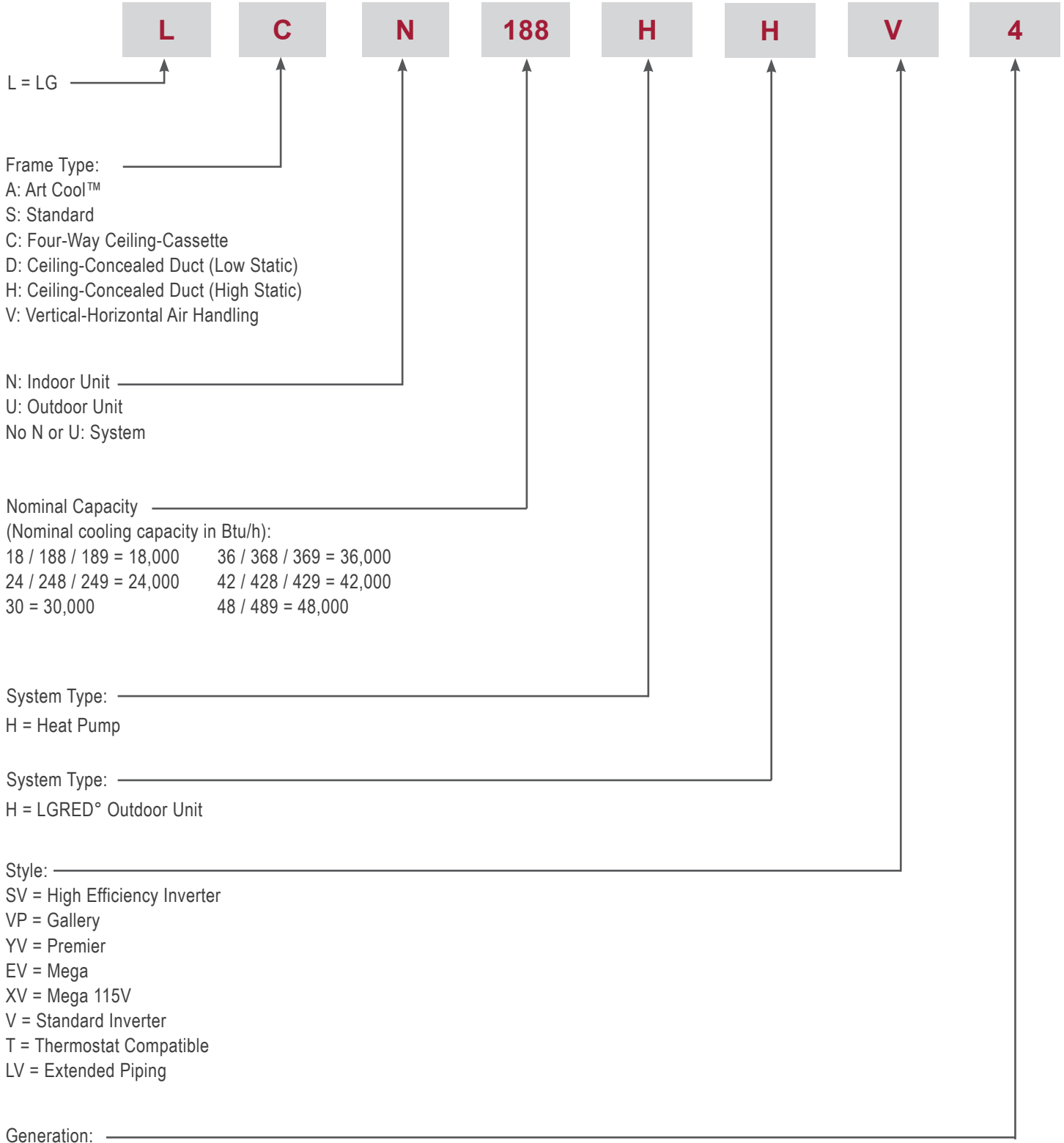

LG Air Conditioner Technical Solution (LATS) Software

A properly designed and installed refrigerant piping system is critical to the optimal performance of LG air-conditioning systems. To assist engineers, LG offers, free of charge, LG Air Conditioner Technical Solution (LATS) software—a total design solution for LG air conditioning systems. Contact your LG Rep for the best software program for your application.

Note:

To reduce the risk of designing an improper applied system or one that will not operate correctly, LG requires that LATS software be used on all projects.

Formats

LATS is available to LG customers in three user interfaces: LATS HVAC, LATS CAD2, and LATS Revit. All three LATS formats are available through www.myLGHVAC.com, or contact an LG Sales Representative.

LATS HVAC is a Windows®-based application that aids engineers in designing LG Variable Refrigerant Flow (VRF), Multi F / Multi F MAX, Single-Zone, and Energy Recovery Ventilator (ERV) systems.

*Windows® is a registered mark of Microsoft® Corporation.

LATS CAD2 combines the LG LATS program with AutoCAD® software**. It permits engineers to layout and validate LG Multi V Variable Refrigerant Flow (VRF), Multi F / Multi F MAX, Single-Zone, and Energy Recovery Ventilator (ERV) systems directly into CAD drawings.

LATS Revit integrates the LG LATS program with Revit® software**. It permits engineers to layout and validate Multi V VRF systems directly into Revit drawings.

**AutoCAD® and Revit® are both registered marks of Autodesk, Inc.

Features

All LG product design criteria have been loaded into the program, making LATS simple to use: double click or drag and drop the component choices. Build systems in Tree Mode where the refrigerant system can be viewed. Switch to a Schematic diagram to see the electrical and communications wiring.

LATS software permits the user to input region data, indoor and outdoor design temperatures, modify humidity default values, zoning, specify type and size of outdoor units and indoor units, and input air flow and external static pressure (ESP) for ducted indoor units.

The program can also:

- Import building loads from a separate Excel file.
- Present options for outdoor unit auto selection.
- Automatically calculate component capacity based on design conditions for the chosen region.
- Verify if the height differences between the various system components are within system limits.
- Provide the correct size of each refrigerant piping segment and LG Y-Branches and Headers.
- Adjust overall piping system length when elbows are added.
- Check for component piping limitations and flag if any parameters are broken.
- Factor operation and capacity for defrost operation.
- Calculate refrigerant charge, noting any additional trim charge.
- Suggest accessories for indoor units and outdoor units.
- Run system simulation.

Note:

Features depend on which LATS program is being used, and the type of system being designed.

Figure 1: Example of LATS CAD2.



LG AIR CONDITIONER TECHNICAL SOLUTION (LATS)

LGRED[®]

LATS Generates a Complete Project Report

LATS software also generates a report containing project design parameters, cooling and heating design data, system component performance, and capacity data. The report includes system combination ratio and refrigerant charge calculations; and provides detailed bill of material, including outdoor units, indoor units, control devices, accessories, refrigerant pipe sizes segregated by building, by system, by pipe size, and by pipe segments. LATS can generate an Excel GERP report that can imported into the LG SOPS pricing and ordering system.

Proper Design to Install Procedure

LG encourages a two report design-to-install-procedure. After the design engineer determines building / zone loads and other details, the engineer opens the LATS program and inputs the project's information. When the design is complete, the "Auto Piping" and "System Check" functions must be used to verify piping sizes, limitations, and if any design errors are present. If errors are found, engineers must adjust the design, and run Auto Piping and System Check again. When the design passes the checks, then the engineer prints out a project "Shop Drawing" (LATS Tree Diagram) and provides it to the installing contractor. The contractor must follow the LATS Tree Diagram when building the piping system, but oftentimes the design changes on the building site:

- Architect has changed location and/or purpose of room(s).
- Outdoor unit cannot be placed where originally intended.
- Structural elements prevent routing the piping as planned.
- Air conditioning system conflicts with other building systems (plumbing, gas lines, etc.).

The contractor must mark any deviation from the design on the Shop Drawing, including as-built straight lines and elbows. This "Mark Up" drawing must be returned to the design engineer or Rep, who must input contractor changes into the LATS file. (Copy the original LATS software file, save and rename as a separate file, and modify all piping lengths by double-clicking on each length and editing information.) Like the shop drawing, the Auto Piping and System Check must also be run on this new "As Built" drawing. The design engineer or Rep must then provide the final As Built file to the contractor. The Mark Up version must be compared to the As Built version for:

- Differences in pipe diameter(s). If incorrect diameters have been installed, the piping must be changed out. If pipe diameters have changed, check to see if Y-Branches will also need to be changed.
- Changes to outdoor unit and indoor unit capacities. Capacities changes will impact line length changes.
- Additional refrigerant charge quantity ("Trim Charge"). Trim charge will change if piping lengths and diameters change. The As Built version must reflect installed piping lengths to ensure correct trim charge.

All documents submitted by the contractor, as well as the Shop Drawing and the As Built Drawing files must be provided for commissioning purposes. Model and serial numbers for all system components must also be submitted. If the steps previously detailed are not followed, and all documents are not provided to the commissioning agent, the project runs the risk of not being commissioned and voiding any limited warranty LG offers on the equipment.

Note:

Contact your LG representative for the best software program for your application.

Figure 2: Example of a LATS Tree Diagram.

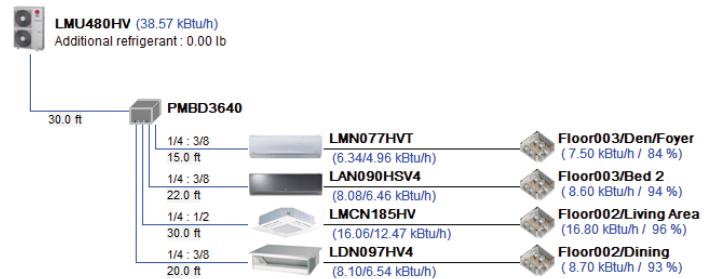

PRODUCT DATA

Mechanical Specifications on page 8

General Data on page 10

Electrical Data on page 13

Functions, Controls, and Options on page 14

Outdoor Unit Dimensions on page 15

Outdoor Unit Center of Gravity / Corner Weights on page 17

Indoor Unit Dimensions on page 18

Acoustic Data on page 21

Refrigerant Flow Diagrams on page 25

Wiring Diagrams on page 30

Electrical Connections on page 35

Air Velocity and Temperature Distribution on page 38

Accessories on page 40

General

System

LG single zone four-way ceiling cassette system comprises of a single frame outdoor unit connected to a single indoor unit with a single refrigerant circuit. An LG single zone four-way ceiling cassette is a system that can operate in either cooling or heating mode. The system is capable of changing mode within a maximum time of three (3) minutes to ensure indoor temperature can be properly maintained. LG components are manufactured in a facility registered to ISO 9001 and ISO 14001, which is a set of standards applying to environmental protection set by the International organization for Standardization (ISO). The system components comply with CSA Standard for Safety and bear the CSA label. Wiring in these units are in accordance with the national Electrical Code (NEC). LG single zone four-way ceiling cassette systems have published performance ratings certified by AHRI (Air-Conditioning, Heating, and Refrigeration Institute) and are listed in the AHRI Standard 210 / 240 certified product directory.

Outdoor Unit

The outdoor units have sound levels not exceeding 56 dB(A) tested in an anechoic chamber under ISO Standard 3745.

Indoor Unit

The indoor units have sound ratings no higher than 56 dB(A) as tested per ISO Standard 3745.

Temperature Ranges

18,000, 24,000, 36,000, 42,000, and 48,000 Btu/h Ceiling Cassette Operating Ranges

- Operating range for outdoor units of 5°F to +118°F (DB) for cooling (Cooling range can be extended from 5°F down to -4°F using the Low Ambient Wind Baffle Kit [sold separately]).
- Operating range for outdoor units of -13°F to +64°F (WB) for heating.
- Operating ranges for indoor units of 57°F to 77°F (WB) for cooling; 59°F to 81°F (DB) for heating.
- Indoor unit temperature setting range of 65°F to 86°F (DB) for cooling; 61°F to 86°F (DB) for heating.

Casing / Frame

Outdoor Unit

The outdoor condensing unit case is constructed from pre-coated metal (PCM) that has been tested in accordance with ASTM B-117 salt spray procedure for a minimum of 1,000 hours. Case has a removable panel to allow access to major internal components, and legs to secure the unit during installation.

Indoor Unit

The indoor unit case is constructed of a galvanized steel plate designed to recess in the ceiling, and has a surface mounted concentric grille on the bottom of the unit. Unit has four supply air outlets and one return air inlet. The supply air outlet has four-directional slot diffusers, each equipped with an independent

oscillating motorized guide vane to change airflow direction. A guide vane algorithm sequentially changes the predominant discharge airflow direction in counterclockwise pattern, or can be used to lock each guide vane independently in a field-adjusted fixed position. The four vanes can be individually adjusted from the wired remote controller to customize the airflow pattern for the conditioned space. A setting in the cooling and heating modes can cycle the vanes up and down for uniform / random air distribution.

The smart dual vane (for 24,000 Btu/h ~ 48,000 Btu/h indoor units only) moves the air dynamically and evenly distributes air to every corner of large space. The dual vane provides optimized angle and provides conditioned air without feeling the draft.

A required architectural grille is sold as a separate required accessory. The four-way grille is off-white acrylonitrile butadiene styrene (ABS) polymeric resin with a tapered trim edge.

The unit has capability of sensing both temperature and humidity to avoid over cooling and maximizing comfort using Humidity sensor (sold separately).

Figure 3: Four-Way 18,000 Btu/h 2x2 Ceiling Cassette System (LC188HHV4).



Refrigerant System

The system is designed for use with R410A refrigerant, and consists of a single refrigeration circuit. The refrigeration circuit is pressure-tested at the factory and shipped with a holding charge of helium gas. The outdoor unit is provided with factory installed components, including a refrigerant strainer, accumulator, four-way reversing valve, electronic expansion valve (EEV), high and low side charging ports, service valves, and interconnecting piping. All refrigerant lines from the outdoor unit to the indoor unit are field-installed and must be insulated separately. LUU420HHV and LUU480HHV include a sub-cooled heat exchanger, vapor injection, and vapor bypass circuit.

Compressors

All of the outdoor units are equipped with one hermetically sealed, digitally controlled, inverter-driven R1 scroll compressor to modulate capacity (modulation in 1 Hz increments). Teflon coated bearings, overcurrent protection and vibration isolation are integrated with the compressor.

Frequency ranges for the 18,000 ~ 48,000 Btu/h outdoor units are:

18k, 24k Btu/h = 10 to 95 Hz Cooling; 10 to 130 Hz Heating
 36k Btu/h = 15 to 120 Hz Cooling; 15 to 135 Hz Heating
 42k, 48k Btu/h = 10 to 120 Hz Cooling; 10 to 135 Hz Heating

Coil

Outdoor Unit

Heat pump outdoor unit coils are made of nonferrous louvered aluminum fins protected with an integral coil guard. The coil for each outdoor unit has a minimum of 14 fins per inch (FPI); heat exchanger has two rows. The coil fins have a factory applied corrosion resistant GoldFin™ material with hydrophilic coating tested in accordance with ASTM B-117 salt spray test procedure for a minimum of 1,000 hours. Coils are factory tested to a pressure of 551 psig.

Indoor Unit

Indoor unit coils are factory built and are comprised of aluminum fins mechanically bonded to copper tubing. Each indoor unit has a minimum of two rows of coils, which are pressure tested to 551 psig at the factory. Each unit is provided with a factory installed condensate drain pan below the coil.

Fans and Motors

Outdoor Unit

The 18,000 Btu/h (LUU180HHV), and 24,000 Btu/h (LUU240HHV) outdoor units include one direct drive, variable speed axial / propeller type fan with a horizontal air discharge; the 36,000 Btu/h (LUU360HHV), 42,000 Btu/h (LUU420HHV), and 48,000 Btu/h (LUU480HHV) include two fans. Fan blades are made of Acrylonitrile Butadiene Styrene (ABS) material, and have a Brushless Digitally Controlled (BLDC) fan motor. The fan motor has inherent protection, permanently lubricated bearings, and variable speed with a maximum speed up to 750 rpm (cooling) and 800 rpm (heating). Raised guards are provided to limit contact with moving parts.

Indoor Unit

All of the indoor units have a single, direct-drive, turbo fan manufactured of high-strength ABS HT-700 polymeric resin; the fans are statically and dynamically balanced. The fan motor is brushless digitally controlled (BLDC) with permanently lubricated and sealed ball bearings. The fan / motor assembly is mounted on vibration-attenuating rubber grommets. Fan speed is controlled using a microprocessor-based direct digital control algorithm that provides pre-programmed, field-selectable fixed or auto fan speeds in the Heating and Cooling modes.

The indoor fan has Low, Med, High, Power Cool, and Auto settings for Cooling mode; and has Low, Med, High, Power Heat, and Auto settings for Heating mode. Auto setting adjusts the fan speed based on the difference between the controller set-point and space temperature.

Air Filter - Indoor Unit

Return air is filtered with a factory-supplied, removable, washable filter accessible from the bottom of the unit. For 2' x 2' cassettes the removable washable filter size is 14" x 14" x 1."

For 3' x 3' cassettes the removable washable filter size is 20.5" x 20.5" x 1."

Electrical

The system was designed to operate using 208–230/60/1 power with voltage variances of ±10% and includes overcurrent protection. The indoor unit is powered through the outdoor unit.

Controls

Indoor and outdoor units are factory wired with necessary electrical control components, printed circuit boards, thermistors, sensors, terminal blocks, and lugs for power wiring. Factory installed microprocessor controls in the outdoor unit and indoor unit shall perform functions to efficiently operate the single zone system, communicating via a 14 AWG four-conductor, stranded, shielded or unshielded (if shielded, must be grounded to the chassis at the outdoor unit only) power/transmission cable (and must comply with applicable local and national codes). Microprocessor-based algorithms provide component protection, soft-start capability, refrigeration system pressure, temperature, defrost, and ambient control. System can be operated through a handheld wireless controller supplied with the four-way ceiling cassette indoor unit.

Condensate Lift / Pump

The indoor unit is provided with a factory installed and wired condensate lift/pump capable of providing a maximum 31-1/2 inch (18k, 24k, 36k, 42k, 48k indoor units) lift from the bottom surface of the unit. Drain pump has a safety switch to shut off the indoor unit if the condensate rises too high in the drain pan.

Figure 4: Four-Way 36,000 to 48,000 Btu/h 3x3 Ceiling Cassette System (LC369HHV, LC429HHV, and LC489HHV Models).



GENERAL DATA



Pairing Table

The following table shows the available outdoor and indoor unit, along with the factory provided controller.

Table 1: Four-Way Ceiling Cassette System Pairing Table









Outdoor Unit Model	Indoor Unit Model	Controller
LUU180HHV 	LCN188HV4 	PQWRHQ0FDB 
LUU240HHV 	LCN249HV 	AKB75735404 
LUU360HHV, LUU420HHV, LUU480HHV 	LCN369HV LCN429HV LCN489HV 	AKB75735404 

Table 2: Single-Zone LGRED Four-Way 2 x 2 Ceiling Cassette System General Data.

System (Model) (Indoor Unit / Outdoor Unit)		LC188HHV4 (LCN188HV4 / LUU180HHV)
Ceiling Grille Model Number (Sold Separately)		PT-UQC / PT-QCHW0
Cooling Capacity (Min ~ Rated ~ Max) (Btu/h)		7,200 ~ 18,000 ~ 24,800
Cooling Power Input ¹ (kW)		0.53 ~ 1.41 ~ 2.85
Heating Capacity (Min ~ Rated ~ Max) (Btu/h)		6,500 ~ 20,000 ~ 23,700
Heating Power Input ¹ (kW)		0.46 ~ 1.80 ~ 2.60
COP @47°F		3.25
<i>Maximum Heating Capacity (Btu/h)</i>		
Outdoor 17°F (WB)/Indoor 70°F (DB)		22,610
Outdoor 5°F (WB)/Indoor 70°F (DB)		20,000
Outdoor 0°F (WB)/Indoor 70°F (DB)		18,850
Outdoor -4°F (WB)/Indoor 70°F (DB)		17,920
Outdoor -13°F (WB)/Indoor 70°F (DB)		15,990
EER		12.80
SEER		20.00
HSPF		11.20
Power Supply V, Ø, Hz ²		208-230 / 1 / 60
<i>Outdoor Unit Operating Range</i>		
Cooling (°F DB)		5 to 118 ⁷
Heating (°F WB)		-13 to +64
<i>Indoor Unit Operating Range</i>		
Cooling (°F WB)		57 to 77
Heating (°F DB)		59 to 81
<i>Indoor Temperature Setting Range</i>		
Cooling (°F DB)		65 to 86
Heating (°F DB)		61 to 86
<i>Unit Data</i>		
Refrigerant Type ³ / Refrigerant Control		R410A / EEV
IDU Sound Pressure Levels ±1 dB(A) (Max/H/M/L/SL) ⁴		43 / 41 / 39 / 36 / 33
Outdoor Unit Sound Pressure Level ±1 dB(A) (Cool/Heat) ⁴		51 / 52
Indoor Unit Net / Shipping Weight (lbs.)		31.5 / 40
Outdoor Unit Net / Shipping Weight (lbs.)		133.4 / 144.4
Grille Net / Shipping Weight (lbs.)		PT-UQC: 6.8 / 11.0; PT-QCHW0: 6.6 / 8.8
Power Wiring / Communications Cable (No. x AWG) ⁵		4 x 14
Compressor (Type x Qty.)		R1 Scroll x 1
Dehumidification Rate (pts./hr.)		4.28
<i>Fan</i>		
Indoor Unit Type x Qty. / Outdoor Unit Type x Qty.		Turbo x 1 / Axial x 1
Motor / Drive		Brushless Digitally Controlled / Direct
<i>Airflow Rate</i>		
Indoor Unit (Max / H / M / L [CFM])		494 / 460 / 424 / 388
Outdoor Unit (CFM)		2,048
<i>Piping</i>		
Liquid (in.)	Connection Size	1/4 Flare
	Pipe Size	3/8 Flare
Vapor (in.)	Connection Size	1/2 Flare
	Pipe Size	5/8 Flare
Condensate Drain O.D. / I.D. (in.)		1-1/4 / 1
Additional Refrigerant Charge (oz./ft.)		0.43
Minimum / Maximum Pipe Length (ft.)		16.4 / 164
Piping Length ⁶ (no additional refrigerant, ft.)		24.9
Maximum Elevation Difference (ft.)		98.4

EEV: Electronic Expansion Valve, IDU: Indoor Unit, ODU: Outdoor Unit. Unit comes with a dry helium charge.
 This data is rated 0 ft above sea level, with 24.6 ft of refrigerant line per indoor unit and a 0 ft level difference between outdoor and indoor units.
 Cooling capacity rating obtained with air entering the indoor coil at 80°F dry bulb (DB) and 67°F wet bulb (WB); and outdoor ambient conditions of 95°F dry bulb (DB) and 75°F wet bulb (WB).
 Heating capacity rating obtained with air entering the indoor unit at 70°F dry bulb (DB) and 60°F wet bulb (WB); and outdoor ambient conditions of 47°F dry bulb (DB) and 43°F wet bulb (WB).
¹Power Input is rated at high speed.
²Power wiring to the ODU is field supplied, solid or stranded, and must comply with the applicable local and national codes.

³Take appropriate actions at the end of HVAC equipment life to recover, recycle, reclaim or destroy R410A refrigerant according to applicable regulations (40 CFR Part 82, Subpart F) under section 608 of CAA.
⁴Sound pressure levels are tested in an anechoic chamber under ISO Standard 3745.
⁵All power wiring/communication cables from ODU to IDU are field supplied and are to be minimum 14 AWG, 4-conductor, stranded, shielded or unshielded (if shielded, must be grounded to chassis at ODU only), and must comply with applicable local and national codes.
⁶Piping lengths are equivalent.
⁷Cooling range can be extended from 5°F down to -4°F using the Low Ambient Wind Baffle Kit (sold separately).

Table 3: Single-Zone LGRED Four-Way 3 x 3 Ceiling Cassette System General Data.

System (Model) (Indoor Unit / Outdoor Unit)	LC249HHV (LCN249HV/ LUU240HHV)	LC369HHV (LCN369HV/ LUU360HHV)	LC429HHV (LCN429HV/ LUU420HHV)	LC489HHV (LCN489HV/ LUU480HHV)
Ceiling Grille Model Number (Sold Separately)	PT-AAGW0	PT-AAGW0	PT-AAGW0	PT-AAGW0
Cooling Capacity (Min ~ Rated ~ Max) (Btu/h)	9,600~24,000~30,000	14,400~36,000~46,000	16,800~42,000~49,000	19,200~48,000~53,000
Cooling Power Input ¹ (kW)	0.48~1.905~3.00	0.72~2.858~5.410	0.93~3.28~5.50	1.09~3.84~5.82
Heating Capacity (Min ~ Rated ~ Max) (Btu/h)	10,800~27,000~33,000	16,000~40,000~46,000	18,000~48,000~57,600	19,000~52,000~61,000
Heating Power Input ¹ (kW)	0.57~2.25~3.80	0.80~3.20~4.70	1.17~3.405~5.80	1.40~3.85~6.20
COP @47°F	3.51	3.66	4.13	3.95
Maximum Heating Capacity (Btu/h)				
Outdoor 17°F (WB)/Indoor 70°F (DB)	29,100	42,100	51,400	55,100
Outdoor 5°F (WB)/Indoor 70°F (DB)	27,000	40,000	48,000	52,000
Outdoor 0°F (WB)/Indoor 70°F (DB)	25,560	37,760	45,200	47,410
Outdoor -4°F (WB)/Indoor 70°F (DB)	24,410	35,970	42,970	43,740
Outdoor -13°F (WB)/Indoor 70°F (DB)	21,610	30,000	35,990	35,980
EER	12.60	12.60	12.80	12.50
SEER	21.00	21.50	19.50	17.50
HSPF	10.20	11.00	11.60	11.70
Power Supply V, Ø, Hz ²	208-230 / 1 / 60			
Outdoor Unit Operating Range				
Cooling (°F DB)	5 to 118 ⁷			
Heating (°F WB)	-13 to +64			
Indoor Unit Operating Range				
Cooling (°F WB)	57 to 77			
Heating (°F DB)	59 to 81			
Indoor Temperature Setting Range				
Cooling (°F DB)	60 to 86			
Heating (°F DB)	60 to 86			
Unit Data				
Refrigerant Type ³ / Refrigerant Control	R410A / EEV			
IDU Sound Pressure Levels ±1 dB(A) (Mx/H/M/L/SL) ⁴	48 / 40 / 37 / 35 / 32	55 / 44 / 42 / 41 / 40	56 / 46 / 43 / 41 / 39	56 / 46 / 43 / 41 / 39
ODU Sound Pressure Level ±1 dB(A) (Cool/Heat) ⁴	51 / 52	52 / 54	54 / 56	54 / 56
Indoor Unit Net / Shipping Weight (lbs.)	45.2 / 54.9	55.8 / 67.7	59.5 / 70.5	59.5 / 70.5
Outdoor Unit Net / Shipping Weight (lbs.)	133.4 / 144.4	198.9 / 223.1	210.9 / 234.1	210.9 / 234.1
Grille Net / Shipping Weight (lbs.)	15.6 / 20.5	15.6 / 20.5	15.6 / 20.5	15.6 / 20.5
Power Wiring / Communications Cable (No. x AWG) ⁵	4 x 14			
Compressor (Type x Qty.)	R1 Scroll x 1			
Dehumidification Rate (pts./hr.)	3.80	7.10	7.27	9.74
Fan				
Indoor Unit Type x Qty. / Outdoor Unit Type x Qty.	Turbo x 1 / Axial x 1	Turbo x 1 / Axial x 2		
Motor / Drive	Brushless Digitally Controlled / Direct			
Airflow Rate				
Indoor Unit (Cooling, Max / H / M / L [CFM])	794 / 671 / 600 / 530	1,200 / 971 / 883 / 794	1,483 / 1,130 / 953 / 812	
Outdoor Unit (CFM)	2,048		4,238	
Piping				
Liquid (in.)	Connection Size	3/8 Flare		
	Pipe Size	3/8 Flare		
Vapor (in.)	Connection Size	5/8 Flare		
	Pipe Size	5/8 Flare		
Condensate Drain O.D. / I.D. (in.)	1-1/4 / 1			
Additional Refrigerant Charge (oz./ft.)	0.43			
Minimum / Maximum Pipe Length (ft.)	16.4 / 164		16.4 / 246	
Piping Length ⁶ (no additional refrigerant, ft.)	24.9			
Maximum Elevation Difference (ft.)	98.4			

EEV: Electronic Expansion Valve, IDU: Indoor Unit, ODU: Outdoor Unit. Unit comes with a dry helium charge.
 This data is rated 0 ft above sea level, with 24.6 ft of refrigerant line per indoor unit and a 0 ft level difference between outdoor and indoor units.
 Cooling capacity rating obtained with air entering the indoor coil at 80°F dry bulb (DB) and 67°F wet bulb (WB); and outdoor ambient conditions of 95°F dry bulb (DB) and 75°F wet bulb (WB).
 Heating capacity rating obtained with air entering the indoor unit at 70°F dry bulb (DB) and 60°F wet bulb (WB); and outdoor ambient conditions of 47°F dry bulb (DB) and 43°F wet bulb (WB).
¹Power Input is rated at high speed.
²Power wiring to the ODU is field supplied, solid or stranded, and must comply with the applicable local and national codes.

³Take appropriate actions at the end of HVAC equipment life to recover, recycle, reclaim or destroy R410A refrigerant according to applicable regulations (40 CFR Part 82, Subpart F) under section 608 of CAA.
⁴Sound pressure levels are tested in an anechoic chamber under ISO Standard 3745.
⁵All power wiring/communication cables from ODU to IDU are field supplied and are to be minimum 14 AWG, 4-conductor, stranded, shielded or unshielded (if shielded, must be grounded to chassis at ODU only), and must comply with applicable local and national codes.
⁶Piping lengths are equivalent.
⁷Cooling range can be extended from 5°F down to -4°F using the Low Ambient Wind Baffle Kit (sold separately).

Table 4: Electrical Data.

Nominal Tons	Unit Model No.	Hertz	Voltage	Voltage Range (Min. to Max.)	MCA	MOP	Compressor Quantity	Compressor Motor RLA		Locked Rotor Amps	Outdoor Unit Fan Motor		Indoor Unit Fan Motor	
								Cooling	Heating		W	FLA	W.	FLA
2 x 2 Four-Way Ceiling Cassettes														
1-1/2	LC188HHV4	60	208 - 230	187 - 253	22	30	1	14.5	14.5	23	460 x 1	1.6 x 1	170	0.6
3 x 3 Four-Way Ceiling Cassettes														
2	LC249HHV	60	208 - 230	187 - 253	22	30	1	14.5	14.5	23	460 x 1	1.6 x 1	170	0.6
3	LC369HHV				32	40		22	22	33	280 x 2	1.6 x 2	230	1.0
3-1/2	LC429HHV				260	1.3								
4	LC489HHV													

Voltage tolerance is ±10%.

Maximum allowable voltage unbalance is 2%.

MCA = Minimum Circuit Ampacity.

Maximum Overcurrent Protection (MOP) is calculated as follows: (Largest motor FLA x 2.25) + (Sum of other motor FLA) rounded down to the nearest standard fuse size.

RLA = Rated Load Amps.

FLA = Full Load Amps.

Table 5: Functions, Controls and Options.

System Type		2x2 Cassette 18K	3x3 Cassette 24K	3x3 Cassette 36K	3x3 Cassette 42K / 48K
Airflow	Air Supply Outlets	4	4	4	4
	Airflow Direction Control	Auto	√ / Six (6) Steps	√ / Six (6) Steps	√ / Six (6) Steps
	Auto Swing (Up and Down)	√	√	√	√
	Airflow Steps (Fan / Cool / Heat)	4 / 5 / 5	4 / 5 / 5	4 / 5 / 5	4 / 5 / 5
	Jet Cool / Jet Heat (Power Wind)	√	√ / √	√ / √	√ / √
	Swirl Wind	X	√	√	√
	Refresh Mode	X	√	√	√
	Smart Mode	X	√	√	√
	Indirect Wind	X	√	√	√
	Direct Wind	X	√	√	√
Filters	Long Life Pre-filter (Washable / Anti-fungal) ¹	√	√	√	√
Oper.	Drain Pump	√	√	√	√
	High Ceiling Operation ²	√	√	√	√
Reliability	Hot Start	√	√	√	√
	Self Diagnosis	√	√	√	√
	De-ice Control (Defrost)	√	√	√	√
	Dry (Dehumidification) Operation	√	√	√	√
	Auto Changeover	√	√	√	√
Convenience	Auto Cleaning (Coil Dry)	√	√	√	√
	Auto Restart	√	√	√	√
	Child Lock ²	√	√	√	√
	Forced Cooling Operation (Outdoor Unit)	√	√	√	√
	Sleep Mode	√	√	√	√
	Timer: 24 hour (On / Off) / 7 hour (Off)	√ / √	√ / √	√ / √	√ / √
	Timer: Weekly ²	√	√	√	√
	Two Thermistor Control ²	√	√	√	√
	Low Ambient Operation	√	√	√	√
	Overheating Protection	X	√	√	√
	ODU Silent Mode / Night Low Noise Operation	√	√	√	√
	Smart Diagnosis	√	√	√	√
	Indoor Unit Display Type	X	One LED	One LED	One LED
	Indoor Unit Display Light	X	On / Off	On / Off	On / Off
	Ener. Sav.	Energy Saving	X	√	√
Energy Control		X	√	√	√
Netwk. Func.	Network Solution (LGAP)	√	√	√	√
Controllers ³	Programmable Controllers (MultiSITE CRC1 / +)	o (PREMTBVC0 / PREMTBVC1)			
	Simple Remote Controller	o (PREMTC00U)	o (PREMTC00U) ³	o (PREMTC00U) ³	o (PREMTC00U) ³
	Premium Remote Controller	o (PREMTA000)	o (PREMTA000)	o (PREMTA000)	o (PREMTA000)
	Wireless Handheld Remote Controller	√ (PQWRHQ0FDB)	√ (AKB75735404)	√ (AKB75735404)	√ (AKB75735404)
	Remote Temperature Button Sensor	o (ZRTBS01)	o (ZRTBS01)	o (ZRTBS01)	o (ZRTBS01)
	Dry Contact	o (PDRYCB100 / 320 / 400)			
Cntrl. Cont./ Integ. Sol.	PI-485	o (PMNFP14A1)	o (PMNFP14A1)	o (PMNFP14A1)	o (PMNFP14A1)
	AC Smart 5	o (PACS5A000)	o (PACS5A000)	o (PACS5A000)	o (PACS5A000)
	ACP 5	o (PACP5A000)	o (PACP5A000)	o (PACP5A000)	o (PACP5A000)
	MultiSITE Communications Manager	o (PBACNBTR0A)	o (PBACNBTR0A)	o (PBACNBTR0A)	o (PBACNBTR0A)
	MultiSITE VM3	o (PBACNBTR1A)	o (PBACNBTR1A)	o (PBACNBTR1A)	o (PBACNBTR1A)
Special Function	Aux. Heat Relay Kit	o (PRARH1)	o (PRARH1)	o (PRARH1)	o (PRARH1)
	Wi-Fi ³	o (PWFMD200)	o (PWFMD200)	o (PWFMD200)	o (PWFMD200)
	Wind Baffle Kit	√ (ZLABGP04A)	√ (ZLABGP04A)	√ (ZLABGP04A x 2)	√ (ZLABGP04A x 2)
	Sheath Heater (Drain Pan Heater)	√	√	√	√
	Smart Inverter Monitoring System (SIMS)	o (PSWMOZ3)	o (PSWMOZ3)	o (PSWMOZ3)	o (PSWMOZ3)
Other	Mode Lock	Cooling Only or Heating Only			
	Temperature Control	√	√	√	√

√ = Standard feature o = Unit option X = Not Available

¹Primary washable filter. 14"x14"x1" for 2x2 units; 20.5"x20.5"x1" for 3x3 units.
²Requires wired zone controller.

³Not all controllers can support all features. Contact your LG representative for details.

Figure 5: LUU180HHV, LUU240HHV Outdoor Unit Dimensions.

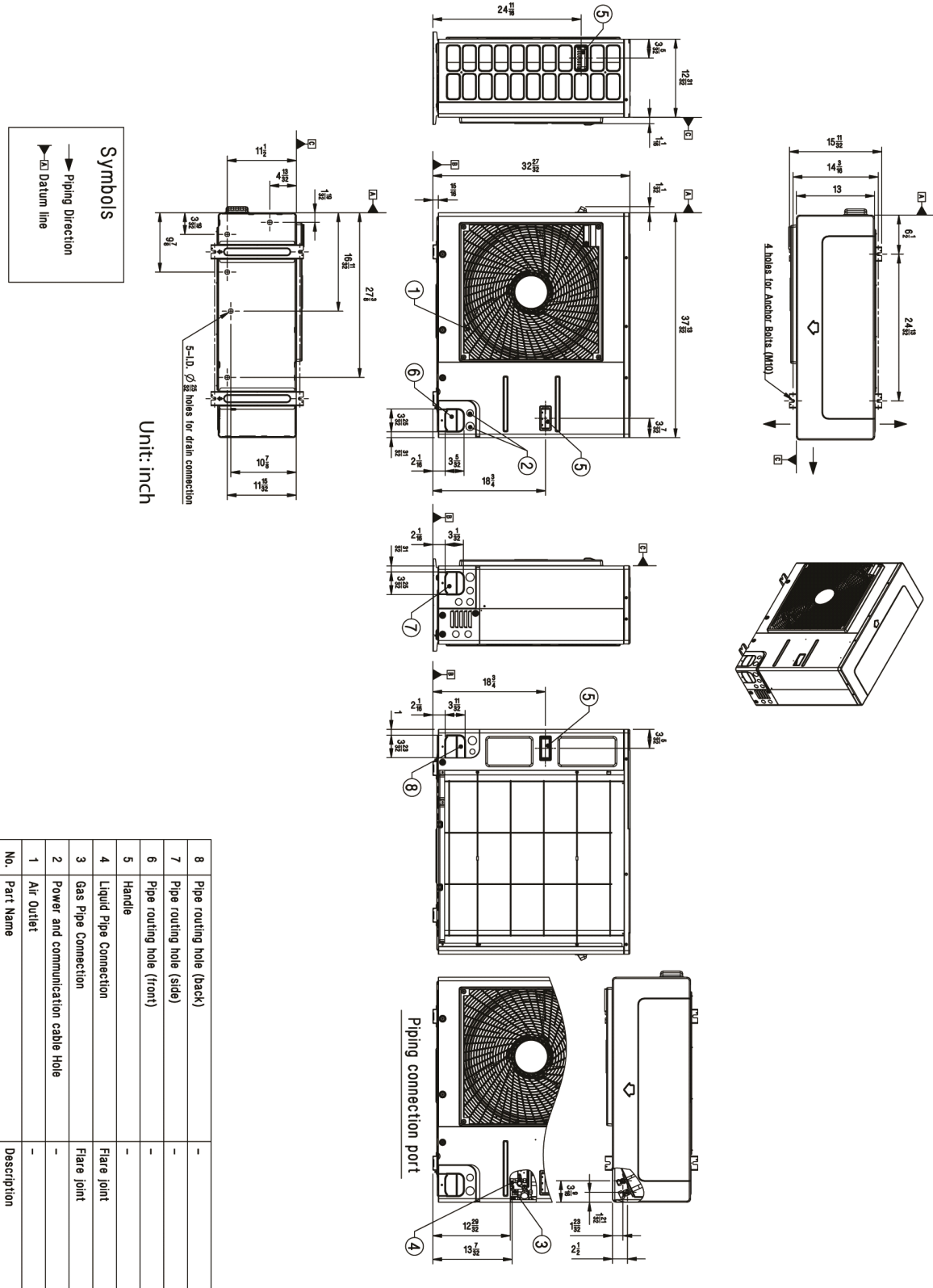

OUTDOOR UNIT DIMENSIONS



LUU360HHV, LUU420HHV, LUU480HHV

Figure 6: LUU360HHV, LUU420HHV, LUU480HHV Outdoor Unit Dimensions.

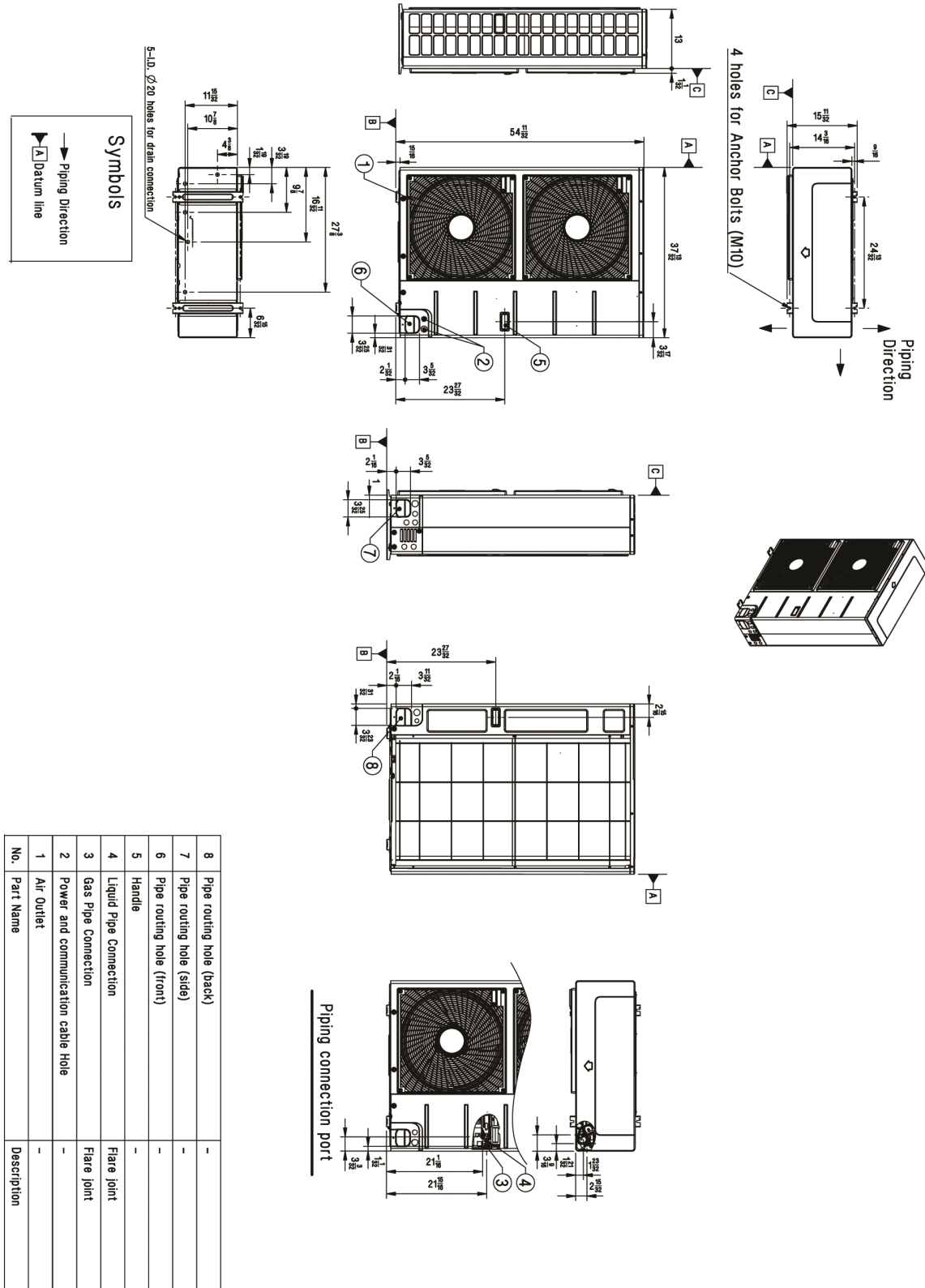

Due to our policy of continuous product innovation, some specifications may change without notification.
 © LG Electronics U.S.A., Inc., Englewood Cliffs, NJ. All rights reserved. "LG" is a registered trademark of LG Corp.



Figure 7: LUU180HHV and LUU240HHV Center of Gravity and Corner Weight Diagram.

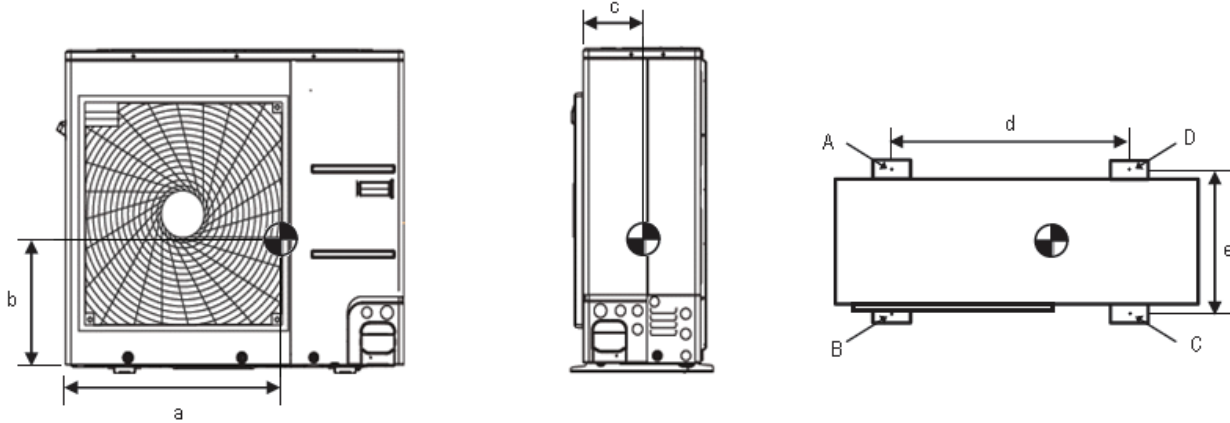

Table 6: LUU180HHV and LUU240HHV Center of Gravity and Corner Weights.

Model No.	Weight (lb.)		Center of Gravity (in.)			Leg (in.)		Corner Weight (lb.)			
	Shipping	Net	a	b	c	d	e	A	B	C	D
LUU180HHV	144.4	133.4	23-7/32	12-19/32	5-29/32	24-13/32	14-3/16	18.8	26.4	51.4	36.7
LUU240HHV	144.4	133.4	23-7/32	12-19/32	5-29/32	24-13/32	14-3/16	18.8	26.4	51.4	36.7

Figure 8: LUU360HHV, LUU420HHV, and LUU480HHV Center of Gravity and Corner Weight Diagram.

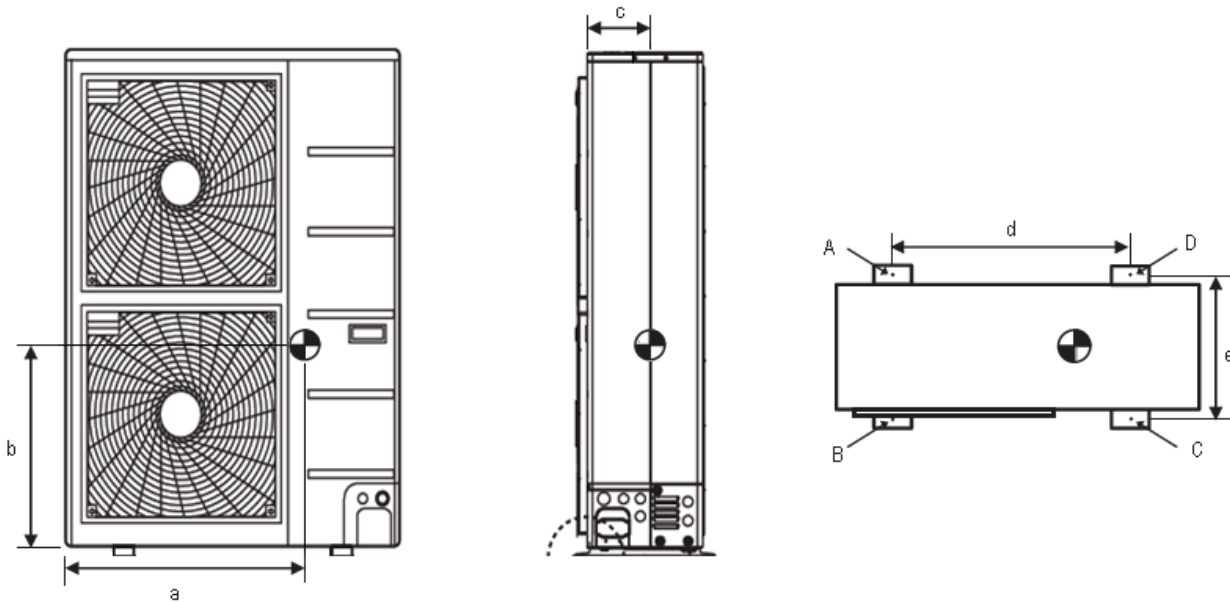

Table 7: LUU360HHV, LUU420HHV, and LUU480HHV Center of Gravity and Corner Weights.

Model No.	Weight (lb.)		Center of Gravity (in.)			Leg (in.)		Corner Weight (lb.)			
	Shipping	Net	a	b	c	d	e	A	B	C	D
LUU360HHV	223.1	198.9	27-7/32	21-15/32	6-5/8	24-13/32	14-3/16	16.3	18.6	87.4	76.6
LUU420HHV	234.1	210.9	27-7/32	21-15/32	6-5/8	24-13/32	14-3/16	17.28	19.72	92.7	81.21
LUU480HHV	234.1	210.9	27-7/32	21-15/32	6-5/8	24-13/32	14-3/16	17.28	19.72	92.7	81.21

Note:

- Design features and information of indoor and outdoor unit may be changed without notifications due to our policy of innovation.
- The center of gravity and corner weight may be different from the actual values because these are simulation results.

INDOOR UNIT DIMENSIONS



LCN188HV4

Figure 9: LCN188HV4 Indoor Unit Dimensions.

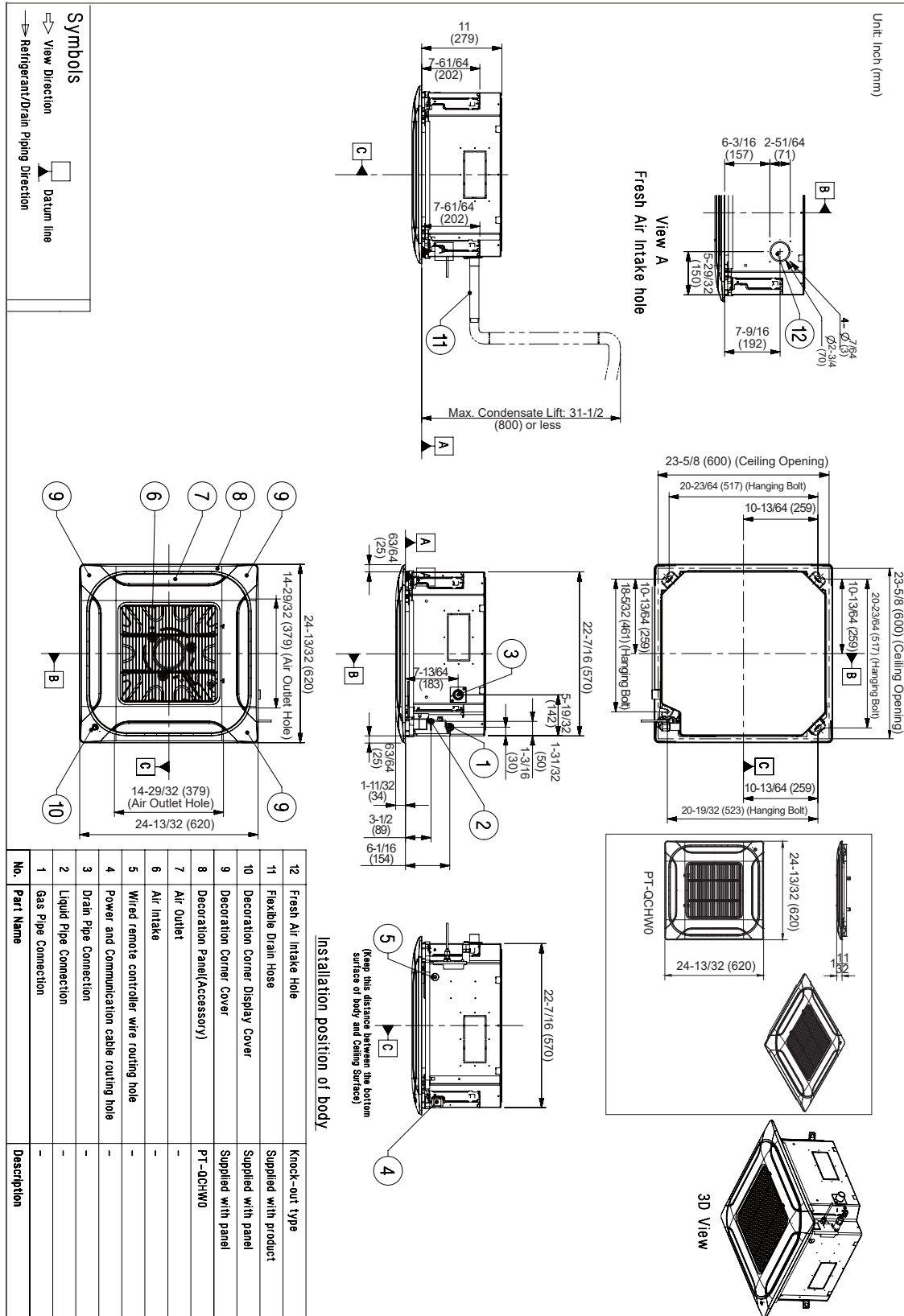

Single-Zone LGRED® Four-Way Ceiling-Cassette System Engineering Manual



Figure 12: Indoor Unit Sound Pressure Level Measurement Location.

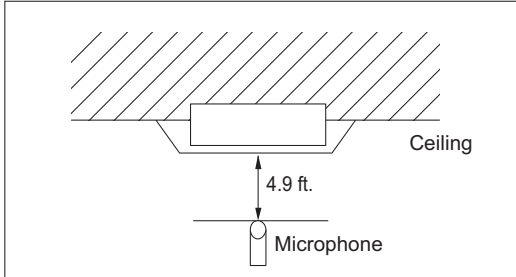

- Measurements taken with no attenuation and units operating at full load normal operating condition.
- Sound level will vary depending on a range of factors such as construction (acoustic absorption coefficient) of particular area in which the equipment is installed.
- Sound pressure levels are measured in dB(A)±1.
- Tested in anechoic chamber per ISO Standard 3745.

Table 8: Four-Way Ceiling Cassette Indoor Unit Sound Levels (dB[A]).

Model	Sound Pressure Levels (dB[A])					
	Cooling			Heating		
	H	M	L	H	M	L
LCN188HV4	41	39	36	41	39	36
LCN249HV	40	37	35	40	37	35
LCN369HV	44	42	41	44	42	41
LCN429HV	46	43	41	46	43	41
LCN489HV	46	43	41	46	43	41

Figure 13: Four-Way Ceiling Cassette Indoor Unit Sound Pressure Level Diagrams.

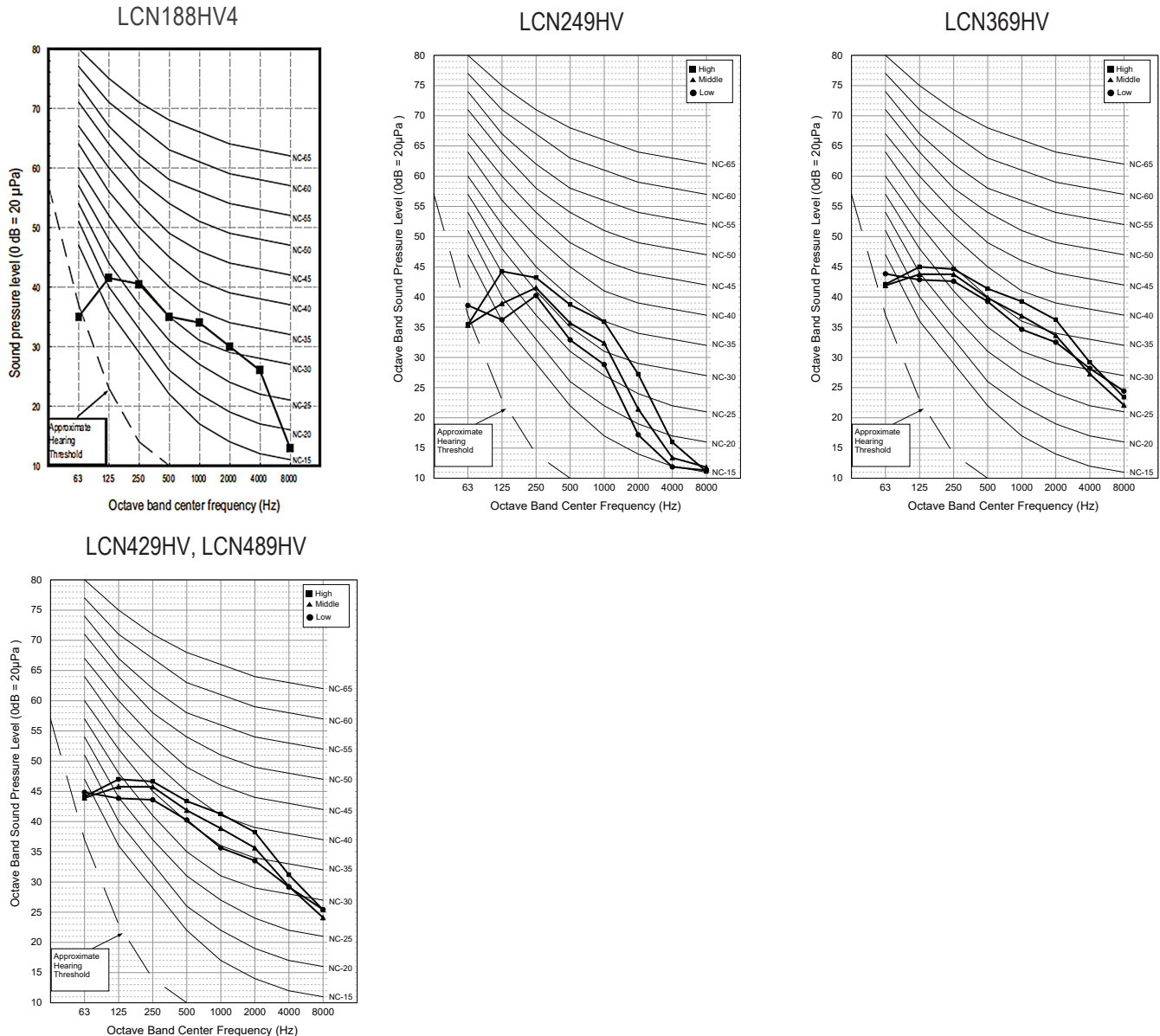

Product Data

ACOUSTIC DATA



Indoor Units

- Data is valid under diffuse field conditions.
- Data is valid under nominal operating conditions.
- Sound power level is measured using rated conditions, and tested in a reverberation room per ISO 3741 standards.
- Sound power level will vary depending on a range of factors such as construction (acoustic absorption coefficient) of particular area in which the equipment is installed
- Reference acoustic intensity $0\text{dB} = 10\text{E-}6\mu\text{W}/\text{m}^2$

Table 9: Four-Way Ceiling Cassette Indoor Unit Sound Power Levels (dB[A]).

Model	Sound Power Levels (dB[A])
LCN188HV4	-
LCN249HV	57
LCN369HV	61
LCN429HV	62
LCN489HV	62

Figure 14: Four-Way Ceiling Cassette Indoor Unit Sound Power Level Diagrams.

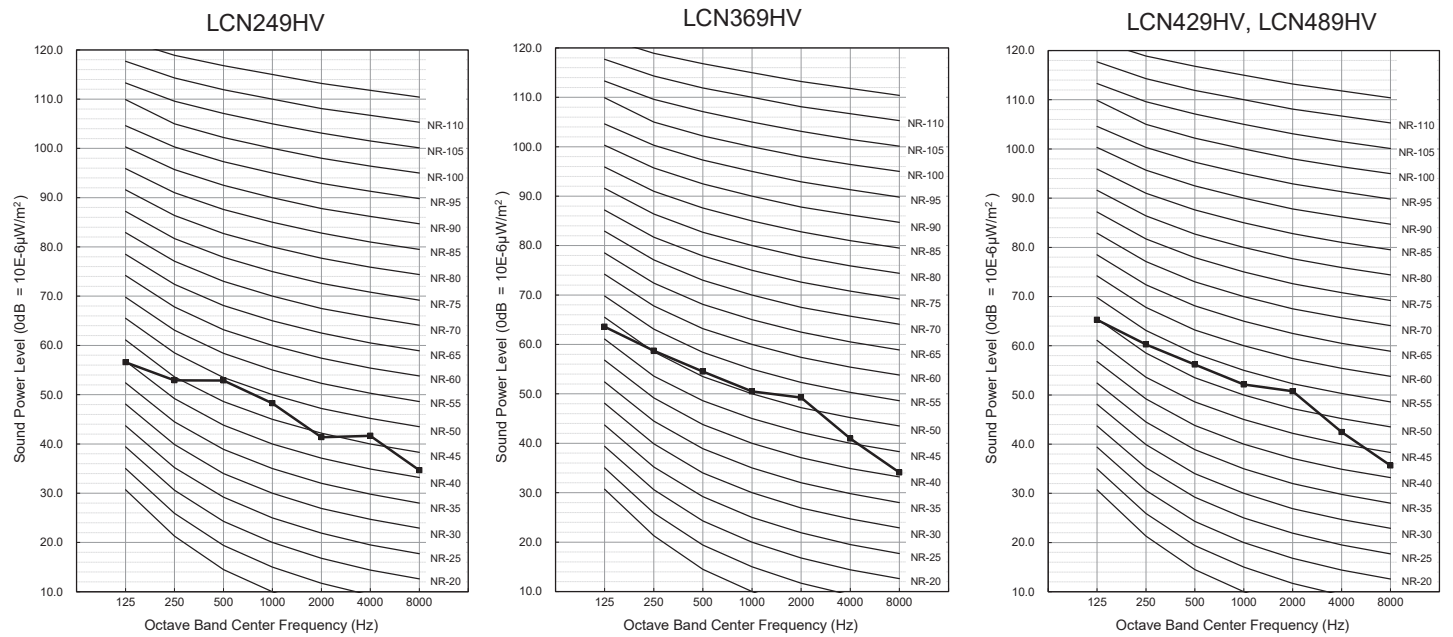
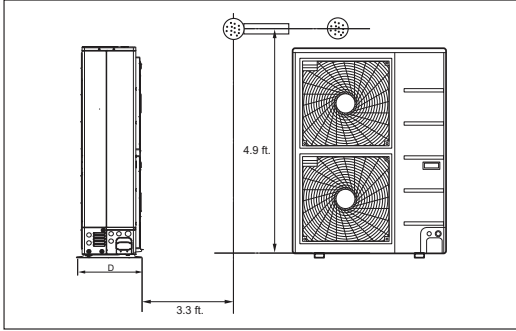

Figure 15: Four-Way Ceiling Cassette Outdoor Unit Sound Pressure Level Measurement Location.



- Measurements taken with no attenuation and units operating at full load normal operating condition.
- Sound level will vary depending on a range of factors such as construction (acoustic absorption coefficient) of particular area in which the equipment is installed.
- Sound pressure levels are measured in dB(A)±1.
- Tested in anechoic chamber per ISO Standard 3745.

Table 10: Four-Way Ceiling Cassette Outdoor Unit Sound Pressure Levels (dB[A]).

Model	Sound Pressure Levels (dB[A])	
	Cooling	Heating
LUU180HHV	51	52
LUU240HHV	51	52
LUU360HHV	52	54
LUU420HHV	54	56
LUU480HHV	54	56

Figure 16: Four-Way Ceiling Cassette Outdoor Unit Sound Pressure Level Diagrams.

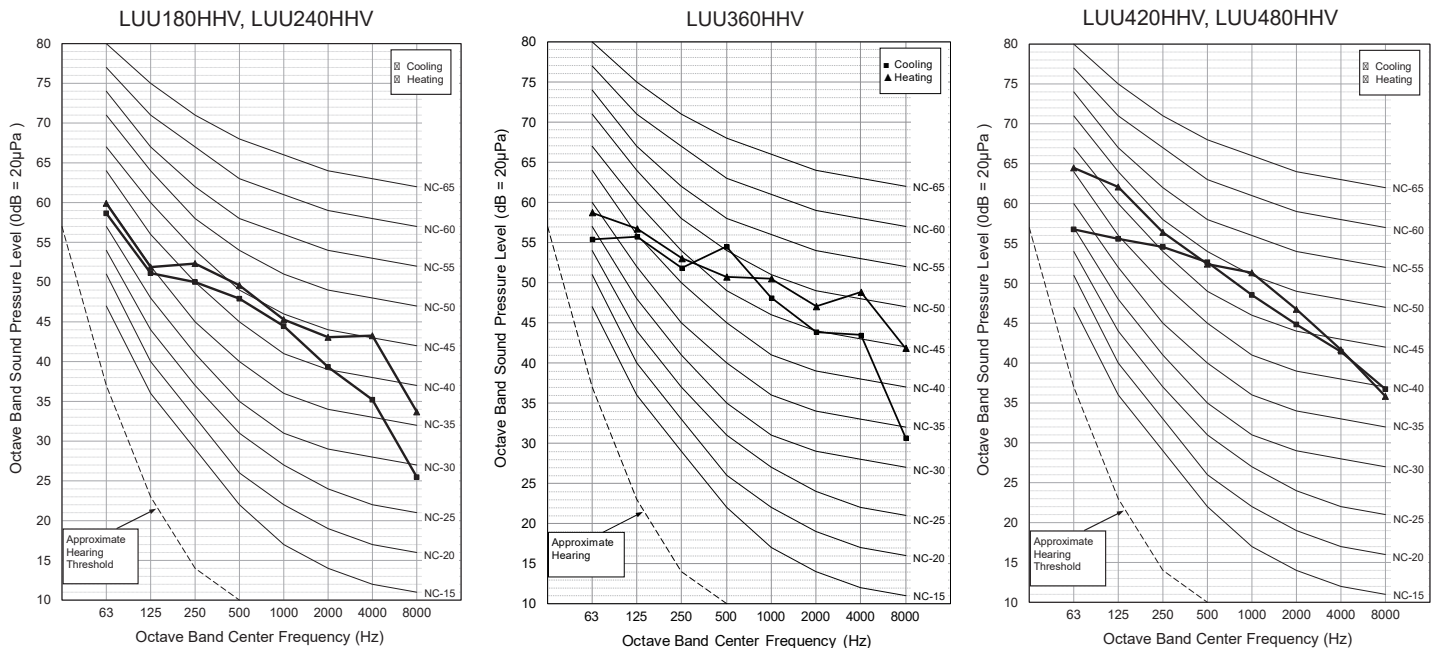

ACOUSTIC DATA



Outdoor Units

- Data is valid under diffuse field conditions.
- Data is valid under nominal operating conditions.
- Sound power level is measured using rated conditions, and tested in a reverberation room per ISO 3741 standards.
- Sound power level will vary depending on a range of factors such as construction (acoustic absorption coefficient) of particular area in which the equipment is installed
- Reference acoustic intensity $0\text{dB} = 10\text{E-}6\mu\text{W}/\text{m}^2$

Table 11: Four-Way Ceiling Cassette Outdoor Unit Sound Power Levels (dB[A]).

Model	Sound Power Levels (dB[A])
LUU180HHV	67
LUU240HHV	67
LUU360HHV	69
LUU420HHV	71
LUU480HHV	71

Figure 17: Four-Way Ceiling Cassette Outdoor Unit Sound Power Level Diagrams.

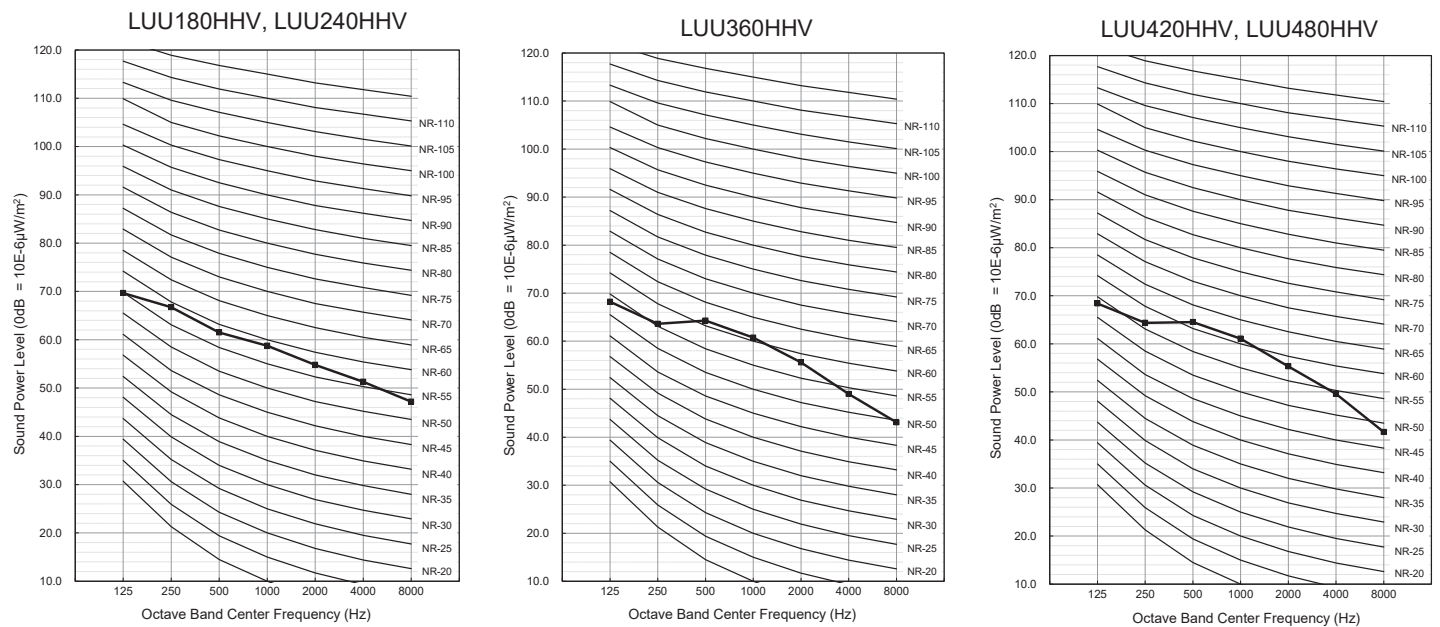

Figure 18: LCN188HV4 Refrigerant Flow Diagram.

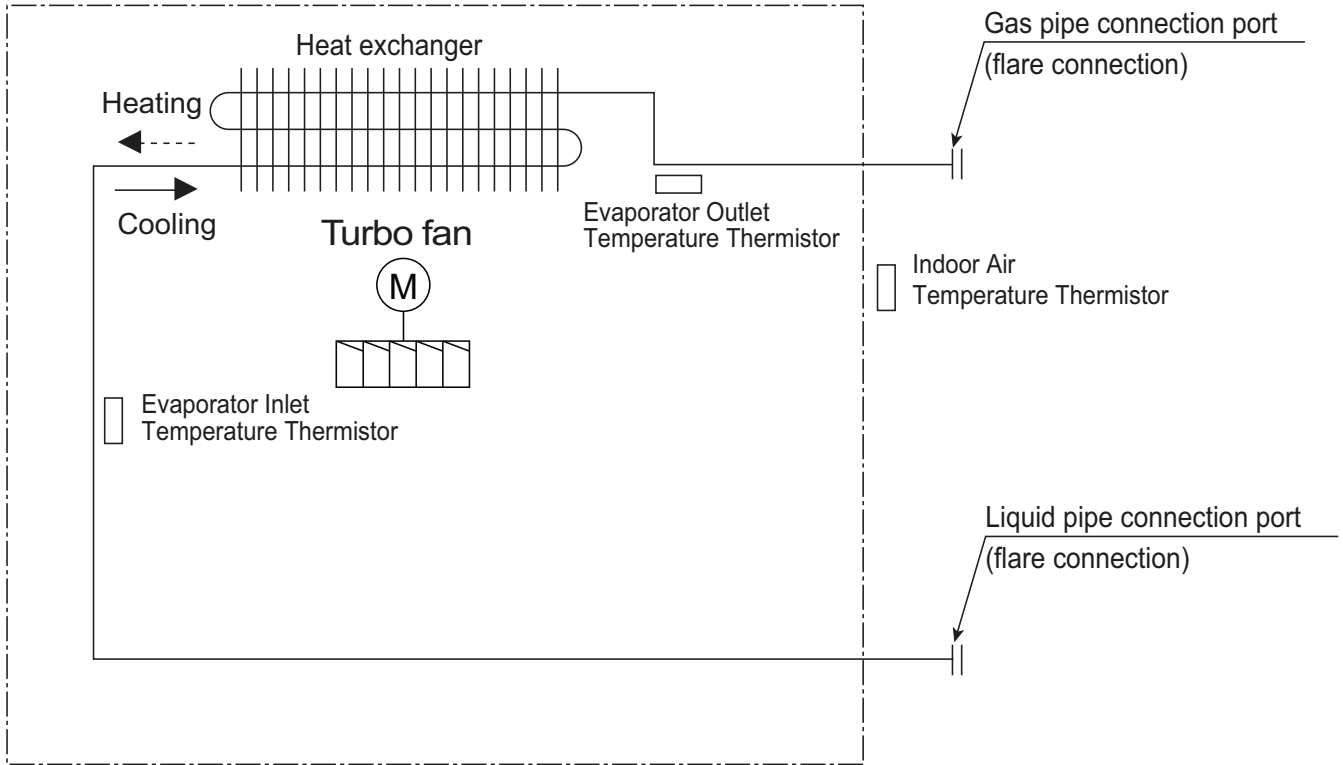

Table 12: LCN188HV4 Four-Way Ceiling Cassette Indoor Unit Thermistor Details.

Description (Based on Cooling Mode)	PCB Connector
Indoor Air Temperature Thermistor	CN-ROOM
Evaporator Inlet Temperature Thermistor	CN-PIPE / IN
Evaporator Outlet Temperature Thermistor	CN-PIPE / OUT

Table 13: LCN188HV4 Four-Way Ceiling Cassette Indoor Unit Refrigerant Pipe Connections.

Model No.	Vapor (inch)	Liquid (inch)
LCN188HV4	1/2	1/4

Table 14: LCN188HV4 Four-Way Ceiling Cassette Indoor Unit Refrigerant Pipe Sizes.

Model No.	Vapor (inch)	Liquid (inch)
LCN188HV4	5/8	3/8

Table 15: LCN188HV4 Connection Socket Dimensions.

Model No.	Vapor (inch)	Liquid (inch)
LCN188HV4	Ø1/2 – Ø5/8	Ø1/4 – Ø3/8

Figure 19: LCN188HV4 Refrigerant Pipe Connections.

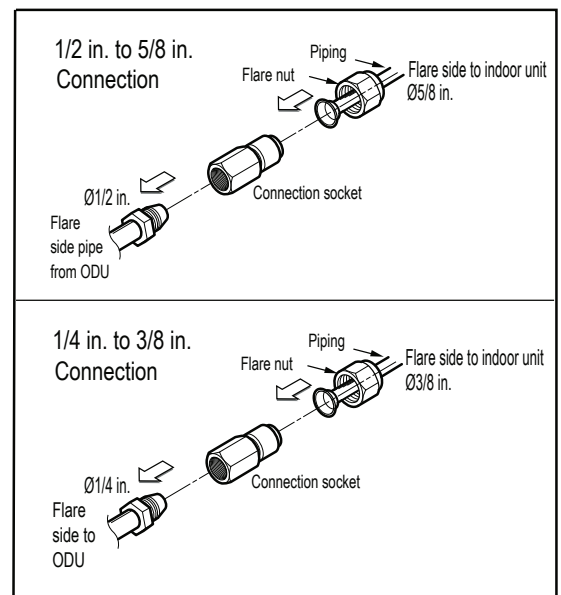

REFRIGERANT FLOW DIAGRAMS

LCN249HV, LCN369HV Indoor Units

Figure 20: LCN249HV, LCN369HV Refrigerant Flow Diagram.

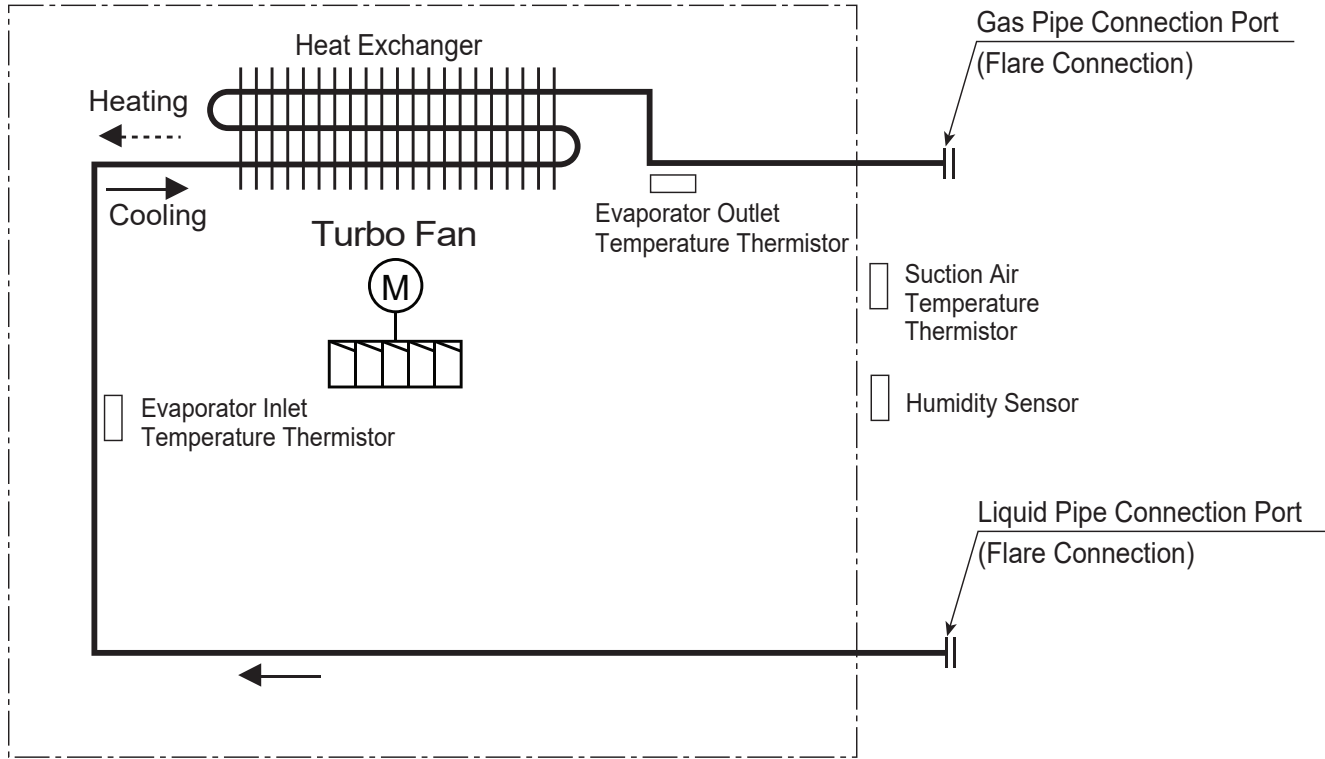

Table 16: LCN249HV, LCN369HV Four-Way Ceiling Cassette Indoor Unit Thermistor Details.

Description (Based on Cooling Mode)	PCB Connector
Suction Air Temperature Thermistor	CN_ROOM
Evaporator Inlet Temperature Thermistor	CN_PIPE_IN
Evaporator Outlet Temperature Thermistor	CN_PIPE_OUT
Humidity Sensor	CN_ROOM_HUMID

Table 17: LCN249HV, LCN369HV Four-Way Ceiling Cassette Indoor Unit Refrigerant Pipe Connections.

Model No.	Vapor (inch)	Liquid (inch)
LCN249HV, LCN369HV	5/8	3/8

Table 18: LCN249HV, LCN369HV Four-Way Ceiling Cassette Indoor Unit Refrigerant Pipe Sizes.

Model No.	Vapor (inch)	Liquid (inch)
LCN249HV, LCN369HV	5/8	3/8

Figure 21: LCN429HV, LCN489HV Refrigerant Flow Diagram.

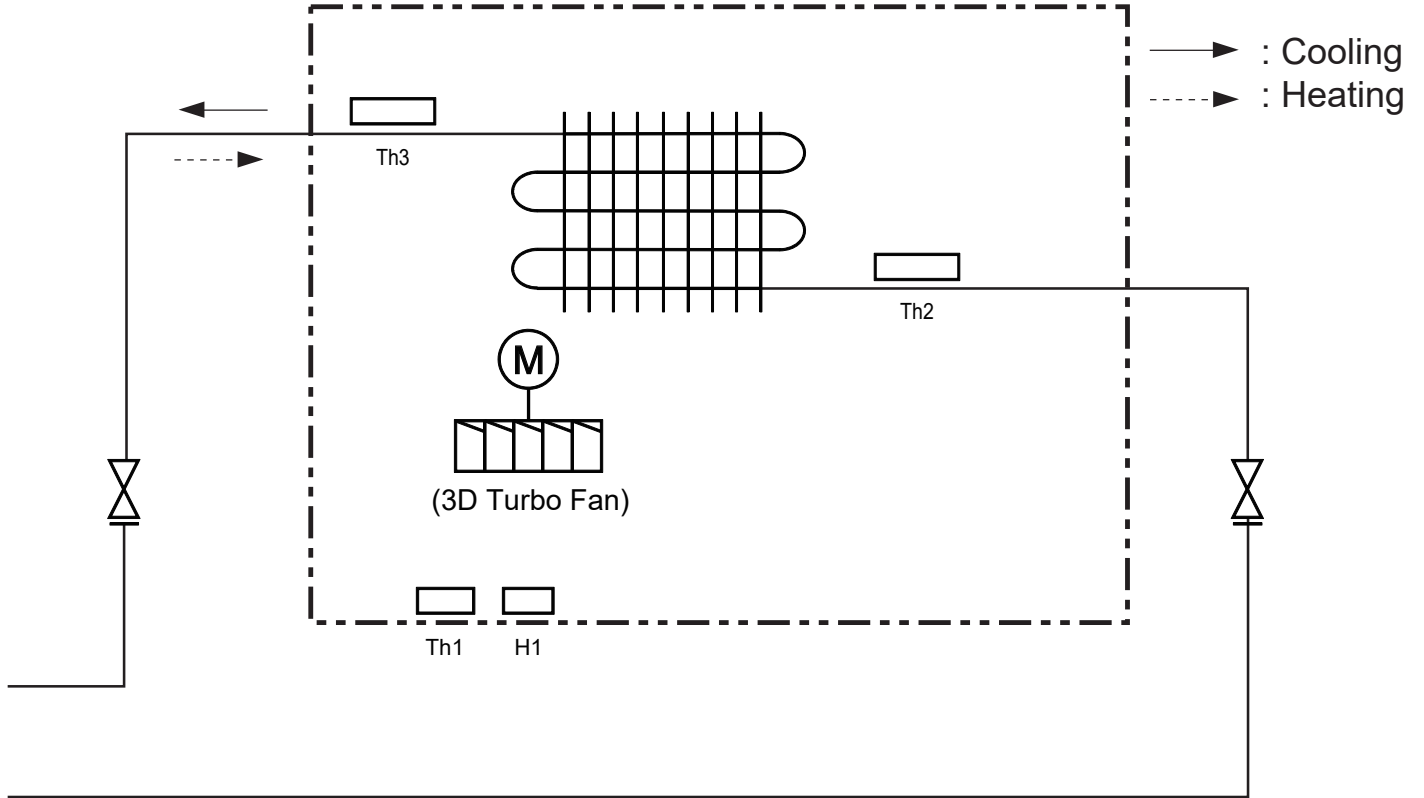

Product Data

Table 19: LCN429HV, LCN489HV Four-Way Ceiling Cassette Indoor Unit Thermistor Details.

Thermistor	Description (Based on Cooling Mode)	PCB Connector
Th1	Indoor Air Temperature Thermistor	CN_ROOM
Th2	Evaporator Inlet Temperature Thermistor	CN_PIPE_IN
Th3	Evaporator Outlet Temperature Thermistor	CN_PIPE_OUT
H1	Humidity Sensor	CN_ROOM_HUMID

Table 20: LCN429HV, LCN489HV Four-Way Ceiling Cassette Indoor Unit Refrigerant Pipe Connections.

Model No.	Vapor (inch)	Liquid (inch)
LCN429HV, LCN489HV	5/8	3/8

Table 21: LCN429HV, LCN489HV Four-Way Ceiling Cassette Indoor Unit Refrigerant Pipe Sizes.

Model No.	Vapor (inch)	Liquid (inch)
LCN429HV, LCN489HV	5/8	3/8

REFRIGERANT FLOW DIAGRAMS



LUU180HHV, LUU240HV, LUU360HV Outdoor Units

Figure 22: LUU180HHV, LUU240HHV, LUU360HHV Refrigerant Flow Diagram.

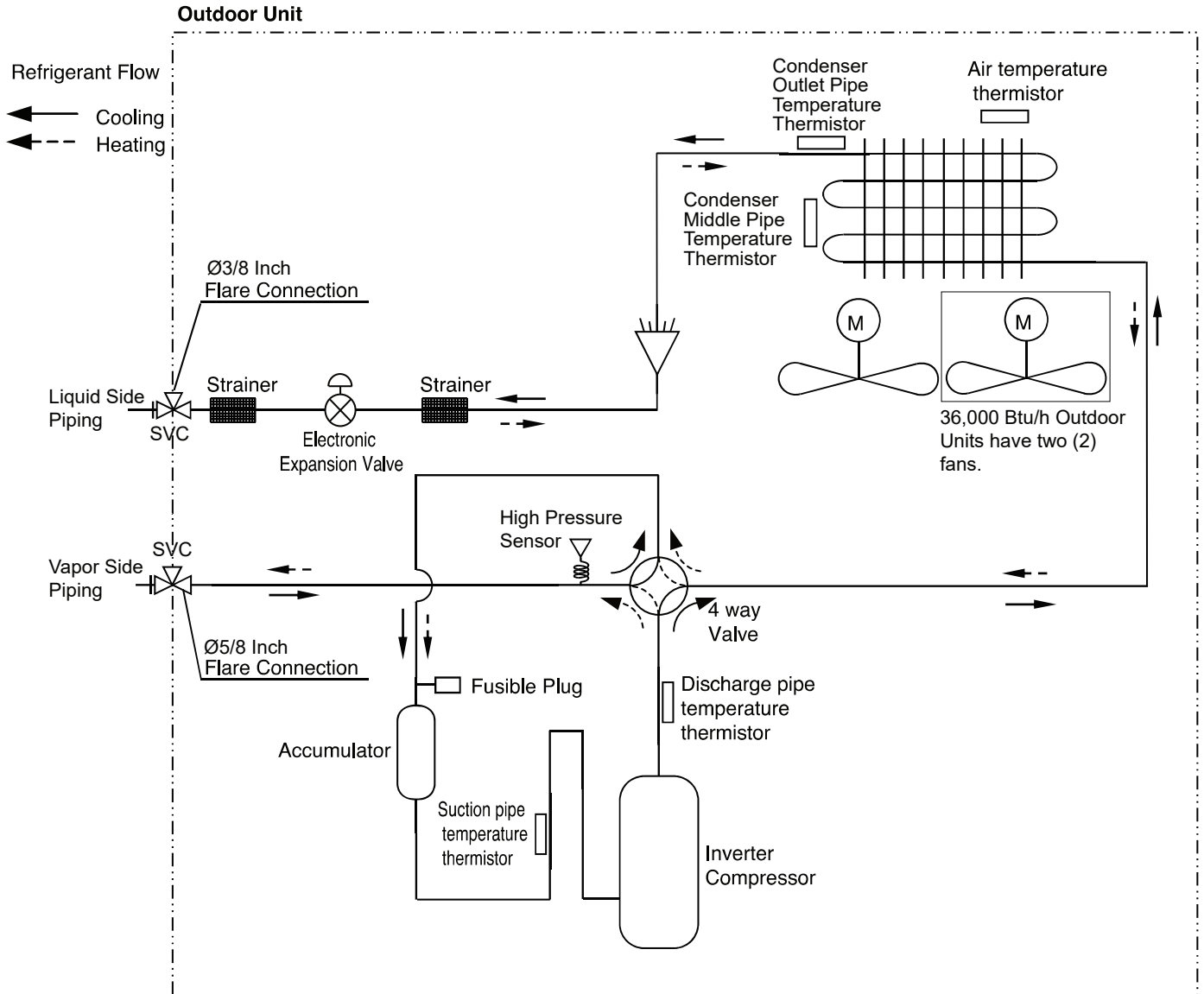
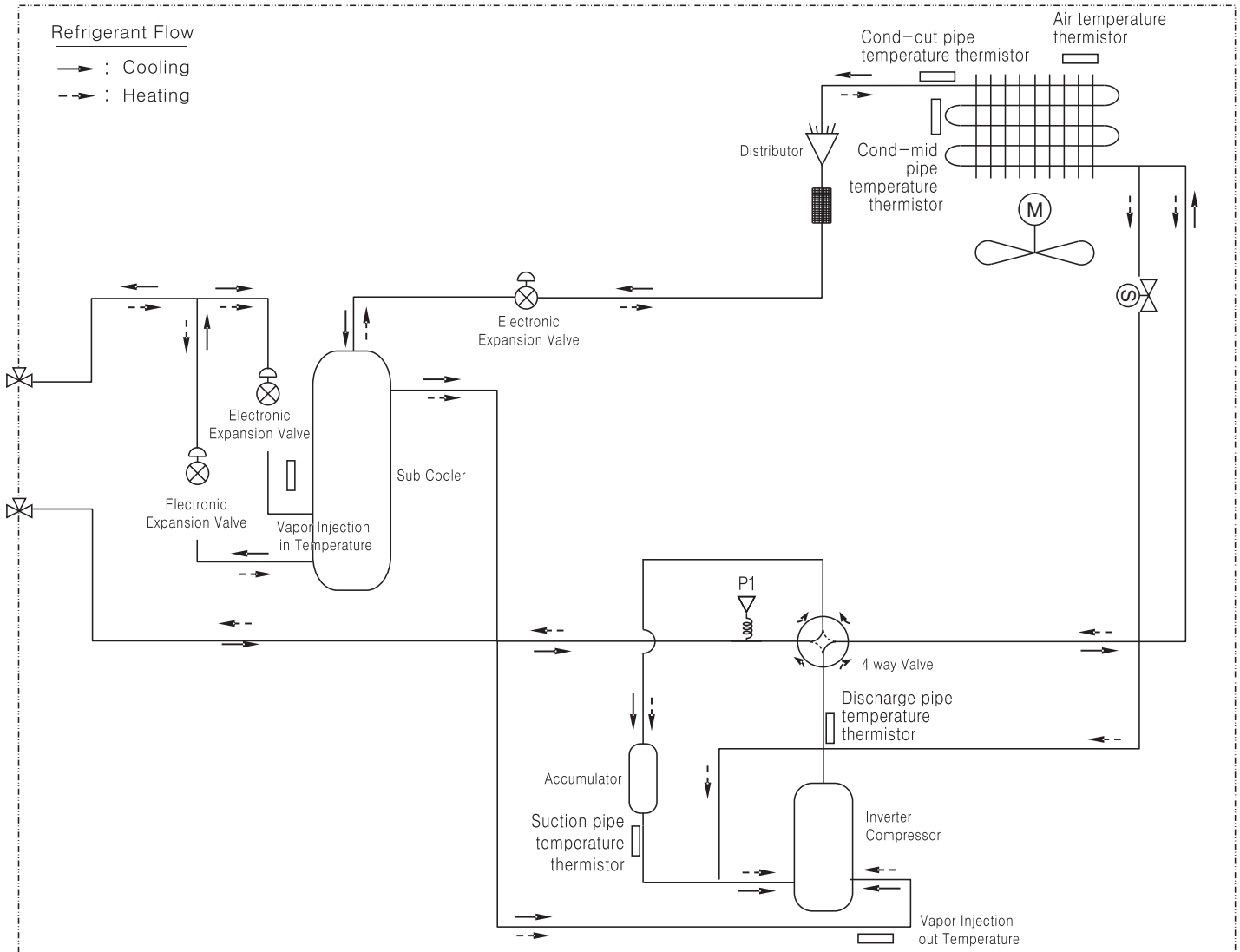

Table 22: LUU180HHV, LUU240HHV, LUU360HHV Four-Way Ceiling Cassette Outdoor Unit Thermistor Details.

Description	PCB Connector
Discharge Pipe Temperature Thermistor	CN_DISCHARGE_BK
Suction Pipe Temperature Thermistor	CN_SUCTION_GR
Condenser Outlet Pipe Temperature Thermistor	CN_C_PIPE_VI
Air Temperature Thermistor	CN_AIR_YL
Condenser Middle Pipe Temperature Thermistor	CN_MID_BR
Pressure Sensor	CN_H_PRESS_RD

Figure 23: LUU420HHV, LUU480HHV Refrigerant Flow Diagram.



Product Data

Table 23: LUU420HHV, LUU480HHV Four-Way Ceiling Cassette Outdoor Unit Thermistor Details.

Description	PCB Connector
Discharge Pipe Temperature Thermistor	CN_DISCHARGE_BK
Suction Pipe Temperature Thermistor	CN_SUCTION_GR
Condenser Outlet Pipe Temperature Thermistor	CN_C_PIPE_VI
Air Temperature Thermistor	CN_AIR_YL
Condenser Middle Pipe Temperature Thermistor	CN_MID_BR
Vapor Injection Inlet Temperature Thermistor	CN_VI_IN_WH
Vapor Injection Outlet Temperature Thermistor	CN_VI_OUT_BL
Pressure Sensor	CN_H_PRESS_RD

Figure 25: LCN249HV, LCN369HV Four-Way Ceiling Cassette Indoor Unit Wiring Diagram.

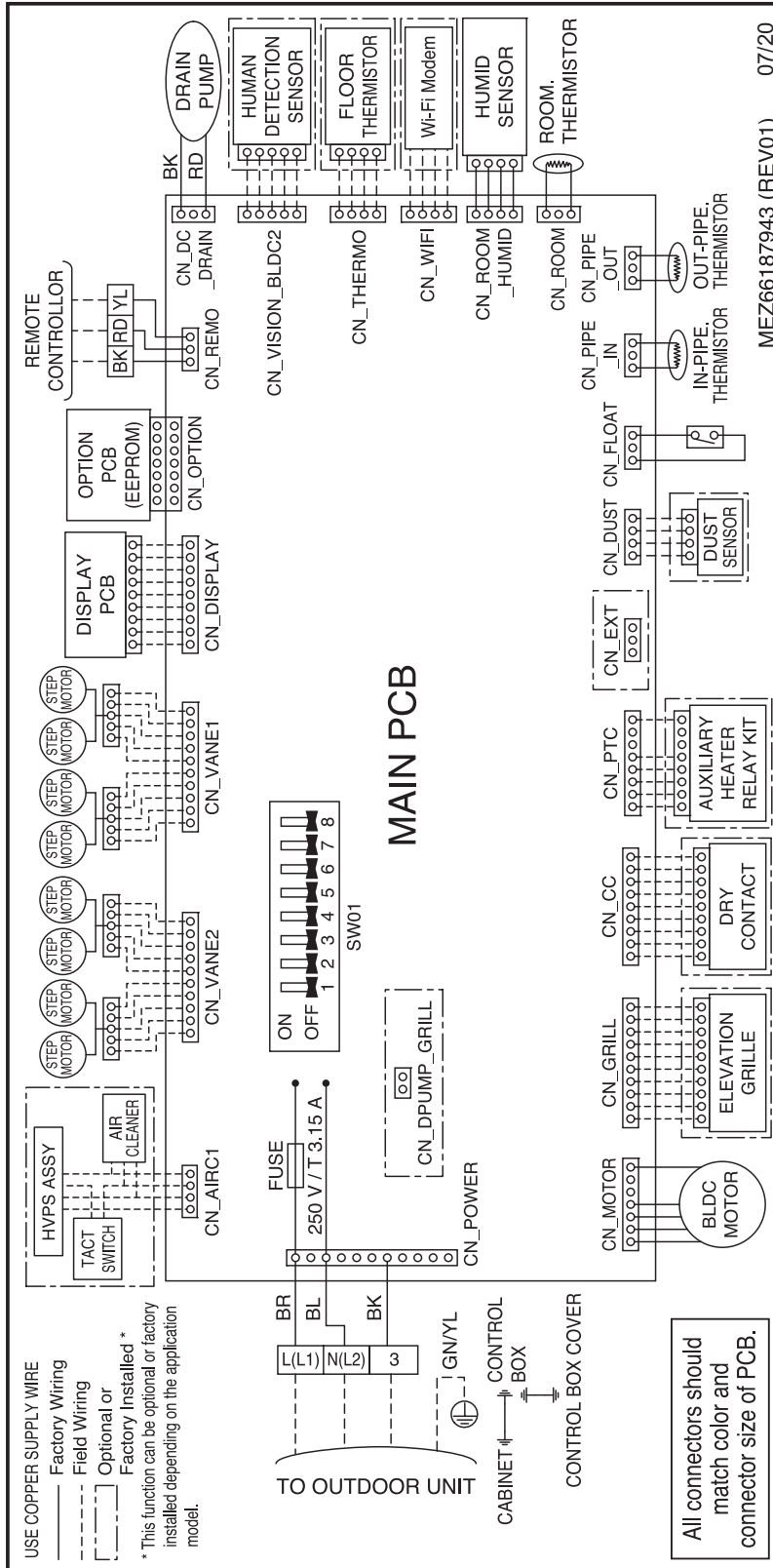

Product Data

WIRING DIAGRAMS

LCN429HV, LCN489HV Indoor Units



Figure 26: LCN429HV, LCN489HV 3x3 Four-Way Ceiling Cassette Indoor Unit Wiring Diagram.

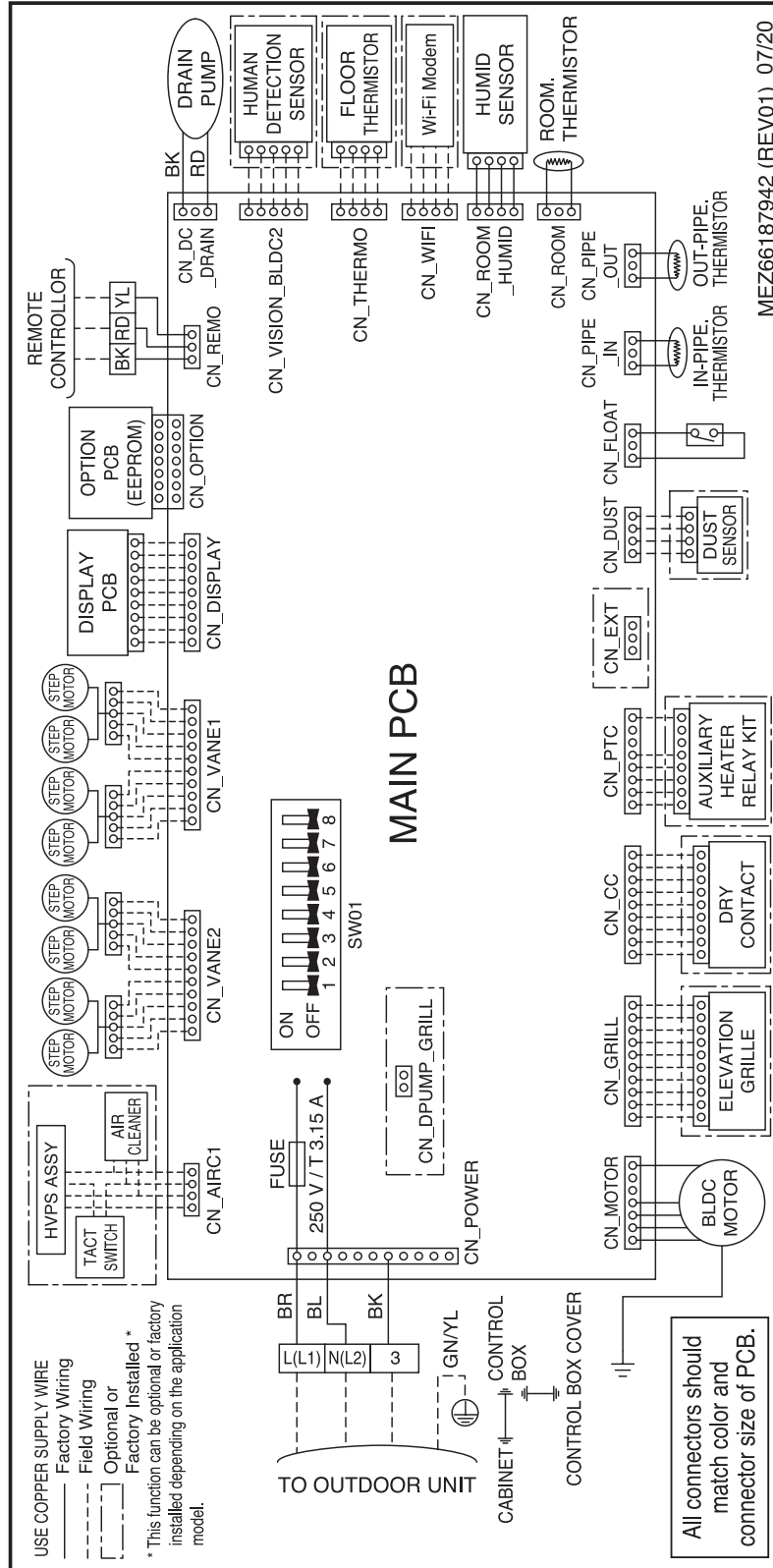

Single-Zone LGRED® Four-Way Ceiling-Cassette System Engineering Manual



Figure 27: LUU180HHV, LUU240HHV Outdoor Unit Wiring Diagram.

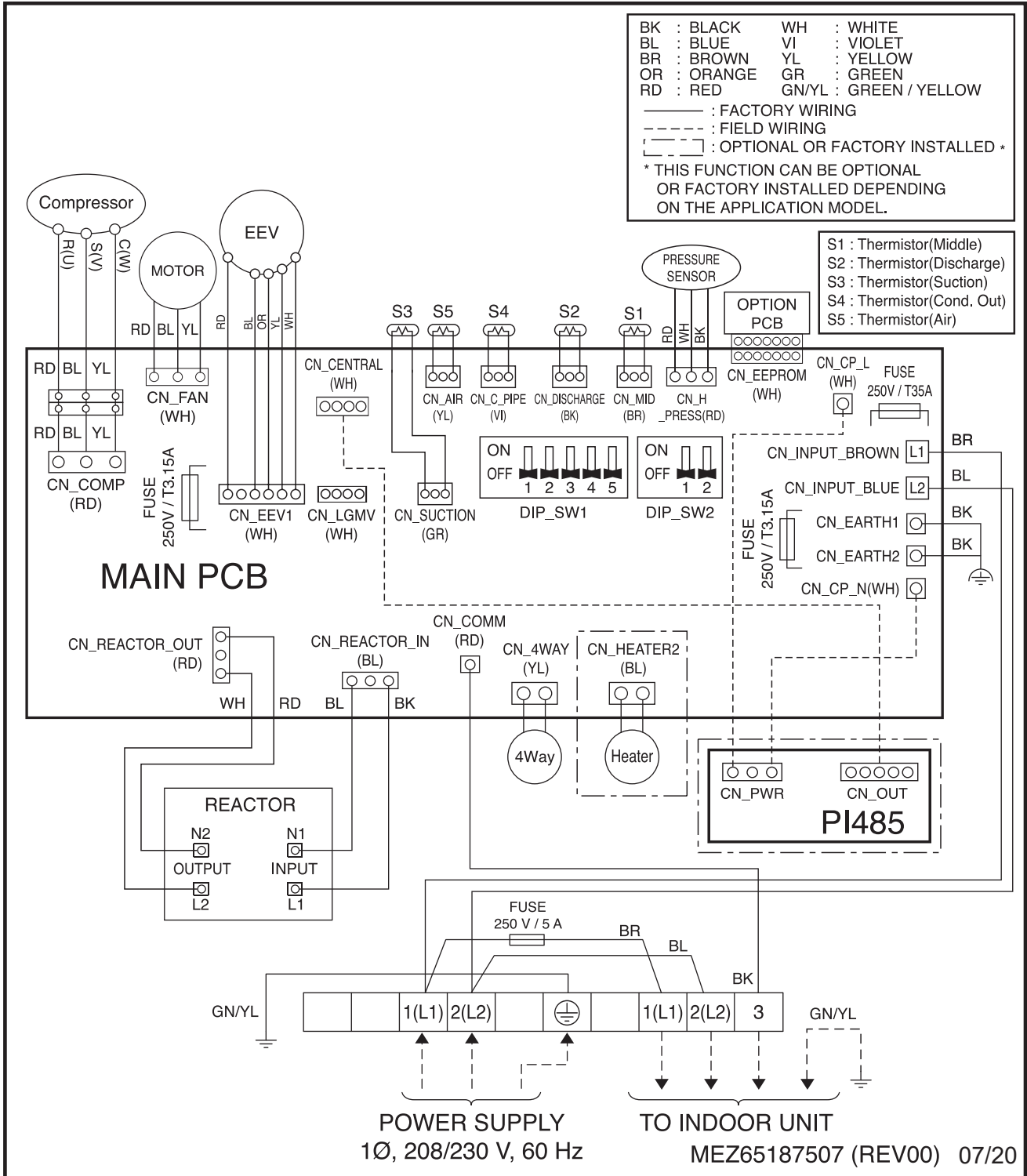

WIRING DIAGRAMS

LUU360HHV, LUU420HHV, LUU480HHV Outdoor Units

Figure 28: LUU360HHV, LUU420HHV, LUU480HHV Outdoor Unit Wiring Diagram.

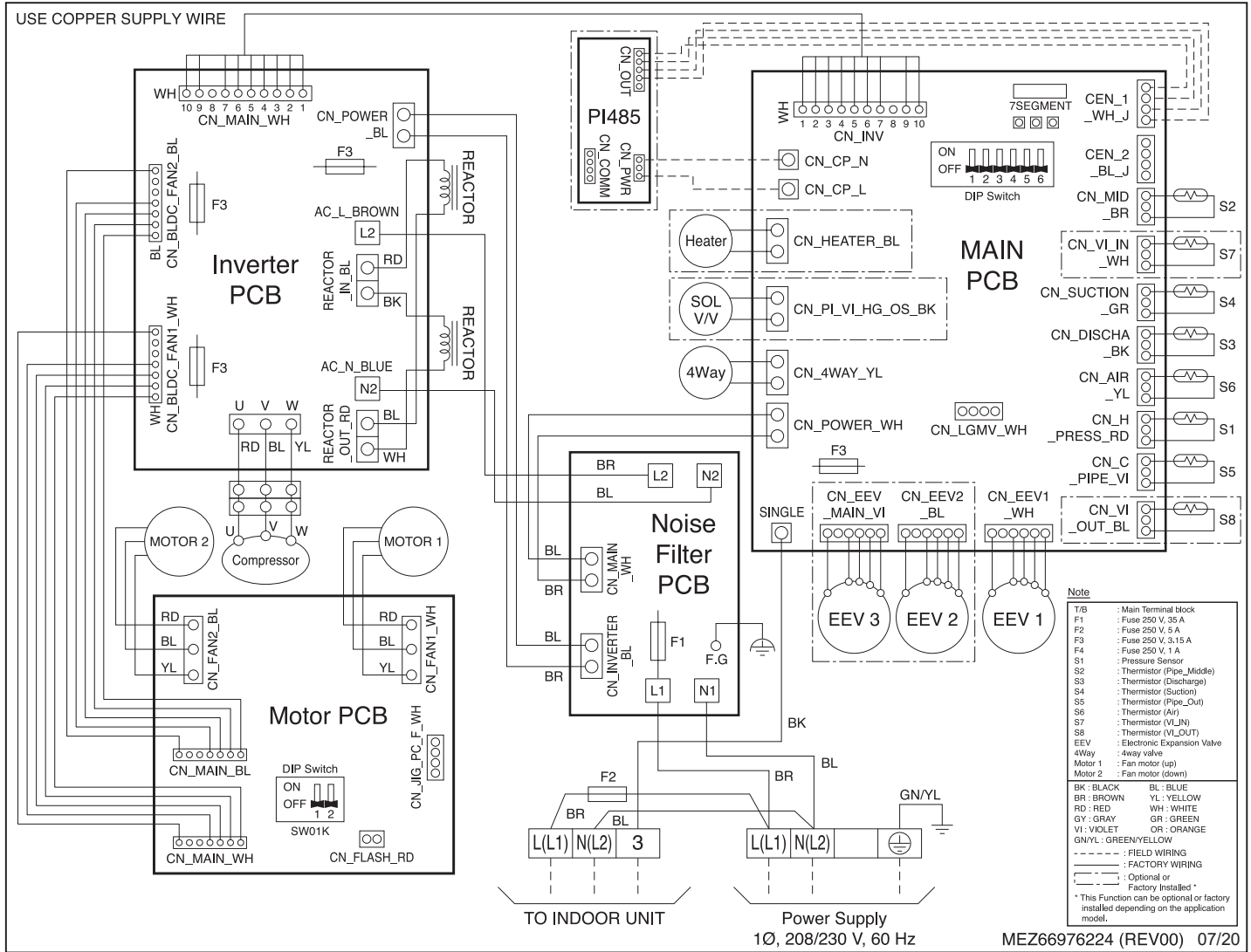

General Power Wiring / Communications Cable Guidelines

- Follow manufacturer's circuit diagrams displayed on the inside of the control box cover.
- Confirm power source specifications.
- Properly ground the outdoor unit and the indoor unit per National Electrical Code (NEC) and local codes.
- Connect the wiring firmly so that the wires cannot be easily pulled out.
- Confirm that the electrical capacity is sufficient.
- Power supply to the outdoor unit must be selected based on NEC and local codes. Maximum allowable voltage fluctuation $\pm 10\%$ or name-plate rated value.
- It is recommended that a circuit breaker is installed, especially if conditions could become wet or moist.
- Include a disconnect in the power wiring system. Add an air gap contact separation of at least 1/8 inch in each active (phase) conductor.
- Any openings where the field wiring enters the cabinet must be completely sealed.

⊘ Do not install power wiring to the outdoor unit and the communication / connection (power) cable from the outdoor unit to the indoor unit in the same conduit. Use separate conduits.

Power Wiring / Communications Cable Specifications

- Power wiring to the outdoor unit must be solid or stranded, and must comply with the applicable local and national electric codes.
- Communication / connection (power) cable from the outdoor unit to the indoor unit must be a minimum of 14 AWG, four (4) conductor, stranded, shielded or unshielded (if shielded, must be grounded to chassis at the outdoor unit only) and must comply with applicable local and national codes.
- Communication cable from the indoor unit to optional remote controller is to be 22 AWG, three (3) conductor, twisted, stranded, unshielded. Wiring must comply with all applicable local and national codes.

⚠ WARNING

- Terminal screws will become loose during transport. Properly tighten the terminal connections during installation or risk electric shock, physical injury, or death.
- Loose wiring will cause unit to malfunction, overheat, and catch fire, resulting in severe injury or death.

Note:

- Terminal screws will loosen during transport. Properly tighten the terminal connections during installation or risk equipment malfunction or property damage.
- Loose wiring will cause unit malfunction, the wires to burnout or the terminal to overheat and catch fire. There is a risk of equipment malfunction or property damage.

A voltage drop will cause the following problems:

- Magnetic switch vibration, fuse breaks, or disturbance to the normal function of an overload protection device.
- Compressor will not receive the proper starting current.

Figure 29: General Four-Way Ceiling Cassette System Power / Communications System Schematic (Appearances May Vary).

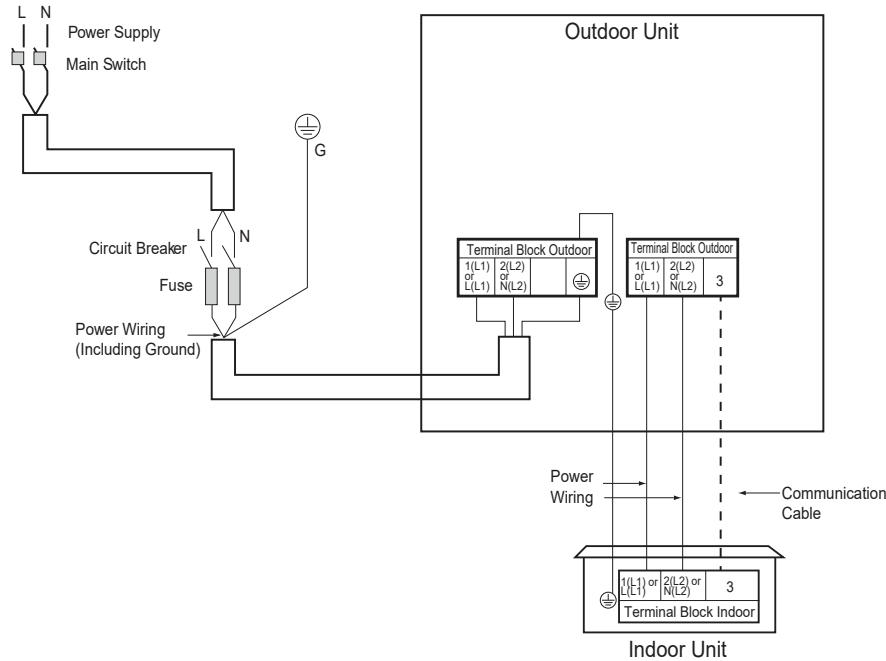

Note:

- Use a conduit for the communications cable / power wiring from the outdoor unit to the indoor units.
- Make sure the communications cable / power wiring from the outdoor units to the indoor units, and the power wiring to the outdoor unit are separate, otherwise, the outdoor unit operation will be affected by electrical noise and will malfunction or fail.

Controller Options

Single Zone LGRED Four-Way Ceiling Cassette systems include a wireless handheld remote controller (18,000 Btu/h models Model No. PQWRHQ0FDB; Part No. AKB73757604 for 18,000 Btu/h cassette indoor units; Part No. AKB75735404 for 24,000 to 48,000 Btu/h cassette indoor units). Optional LG-supplied wired controllers are available. See “Functions, Controls, Options”, or contact an LG representative for more information.

Figure 30: PQWRHQ0FDB (AKB73757604) Wireless Handheld Remote Controller for 18,000 Btu/h Cassette Indoor Units.

Wireless Handheld Remote Controller features:

- Display Panel: Displays operation conditions.
- On / Off Buttons: Turns system operation on and off.
- Mode Button: Selects the operation mode: Cooling, Heating, Auto, Dry (Dehumidification), or Fan.
- Temp Up / Down Buttons: Adjusts the desired room temperature in the different modes.
- Fan Speed Button: Sets desired fan speed.
- Reset: Initializes the handheld remote control settings.

Wired Controller Connections

Optional controllers (see “Functions, Controls, Options”, or contact an LG representative for more information) can connect to the Four-Way Ceiling Cassette indoor unit in one of two different ways.

1. LG Wired Remote Extension Cable with Molex plug (PZCWRC1; sold separately) that connects to the CN-REMO terminal on the indoor unit PCB.
2. Field-supplied controller cable that connects to the indoor unit terminal block (must be at least UL2547 or UL1007, and at least FT-6 rated if local electric and building codes require plenum cable usage). Communication cable from indoor unit to remote controller(s) is to be 22 AWG, 3-conductor, twisted, stranded, unshielded. Wiring must comply with all applicable local and national codes.

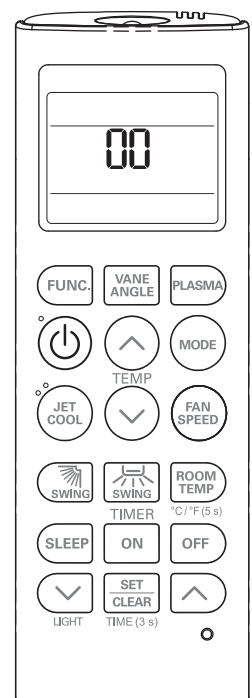

Note:

When using field-supplied controller cable, make sure to connect the yellow to yellow (communications wire), red to red (12V power wire), and black to black (ground wire) terminals from the remote controller to the indoor unit terminal blocks.

Figure 32: PZCWRC1 LG Wired Remote Extension Cable.

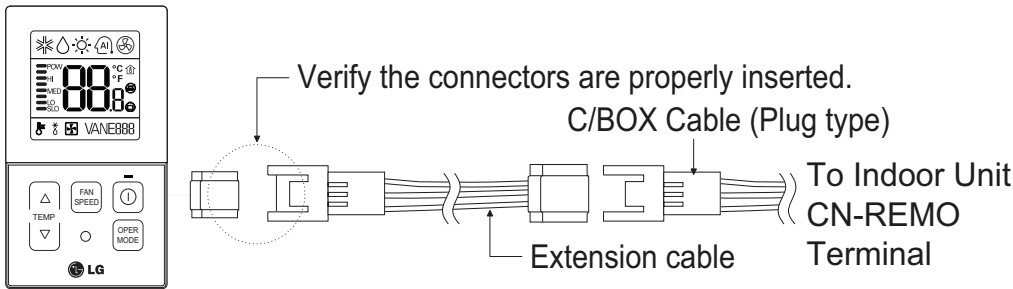
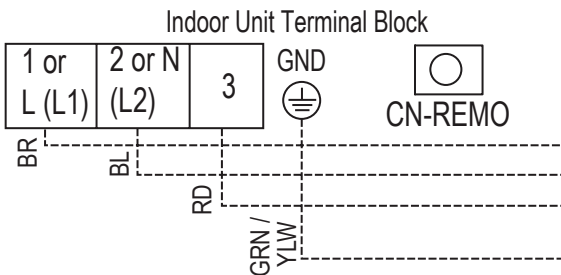

Figure 33: Wired Controller Connection (Example Only).



Wired Controller Placement

Wired controllers include a sensor to detect room temperature. To maintain comfort levels in the conditioned space, the wired controller must be installed in a location away from direct sunlight, high humidity, and where it could be directly exposed to cold air. Controller must be installed four (4) to five (5) feet above the floor where its LED display can be read easily, in an area with good air circulation, and where it can detect an average room temperature.

- ⊘ Do not install the wired controller near or in:
 - Drafts or dead spots behind doors and in corners.
 - Hot or cold air from ducts.
 - Radiant heat from the sun or appliances.
 - Concealed pipes and chimneys.
 - An area where temperatures are uncontrolled, such as an outside wall.

Figure 31: Proper Location for the Wired Controller.

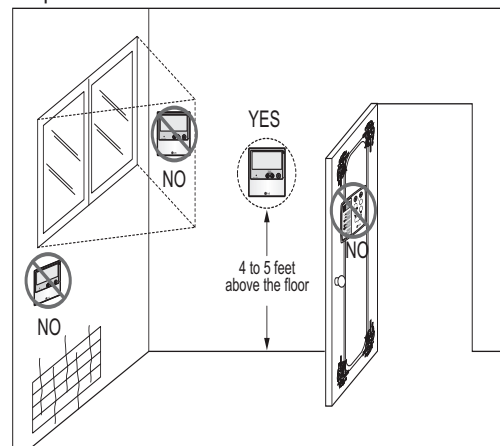

Assigning the Thermistor for Temperature Detection

Each indoor unit includes a return air thermistor assigned to sense the temperature. If a wired controller is installed, there is a choice of sensing temperature with either the indoor unit return air thermistor or the thermistor in the wired controller. It is also an option to set both thermistors to sense temperature so that indoor unit bases its operation on the first thermistor to reach the designated temperature differential.

AIR VELOCITY AND TEMPERATURE DISTRIBUTION

Figure 34: LCN188HV4 Air Velocity and Temperature Distribution Charts.

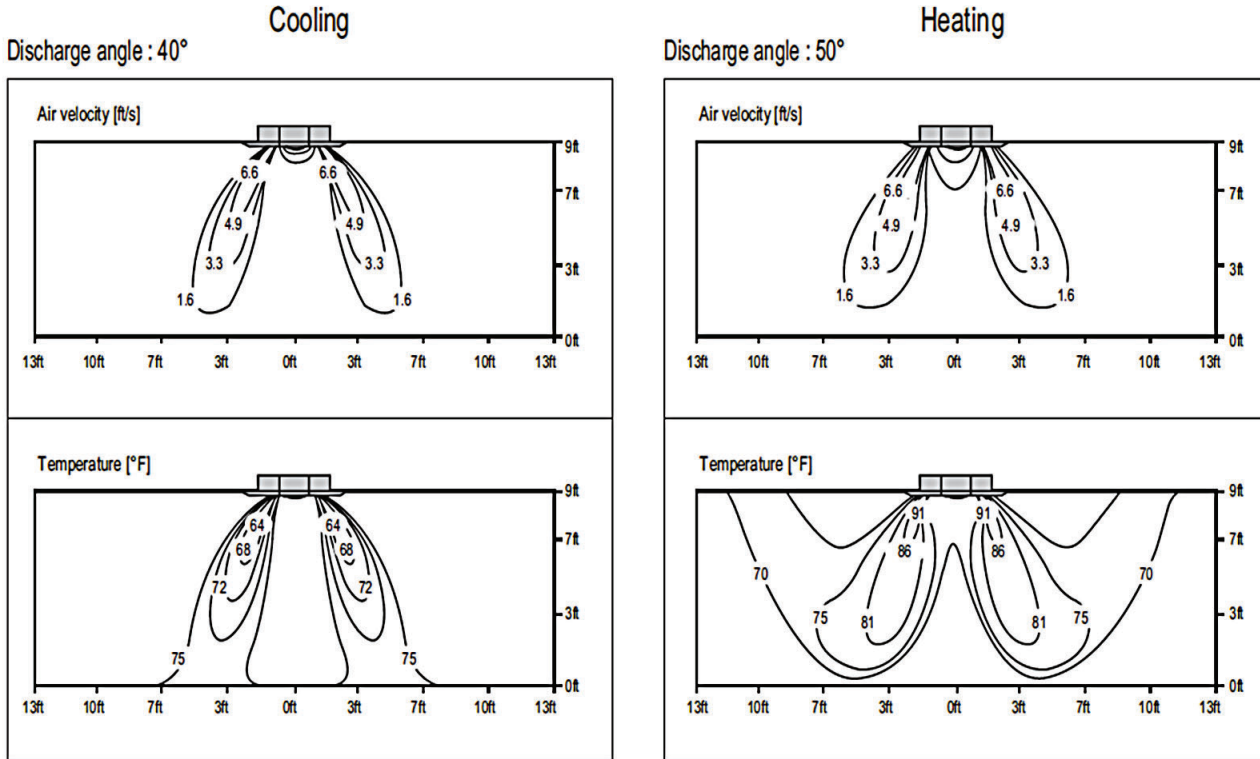

Figure 35: LCN249HV Air Velocity and Temperature Distribution Charts.

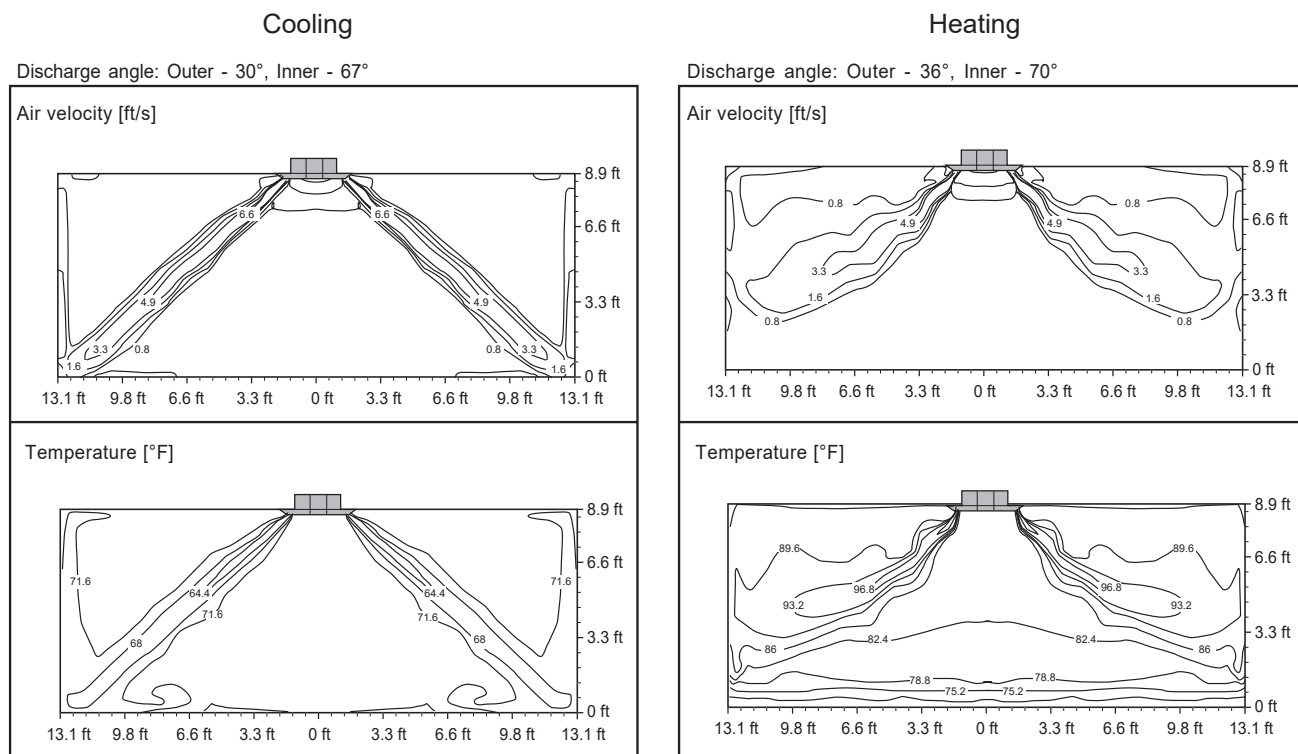

Figure 36: LCN369HV Air Velocity and Temperature Distribution Charts.

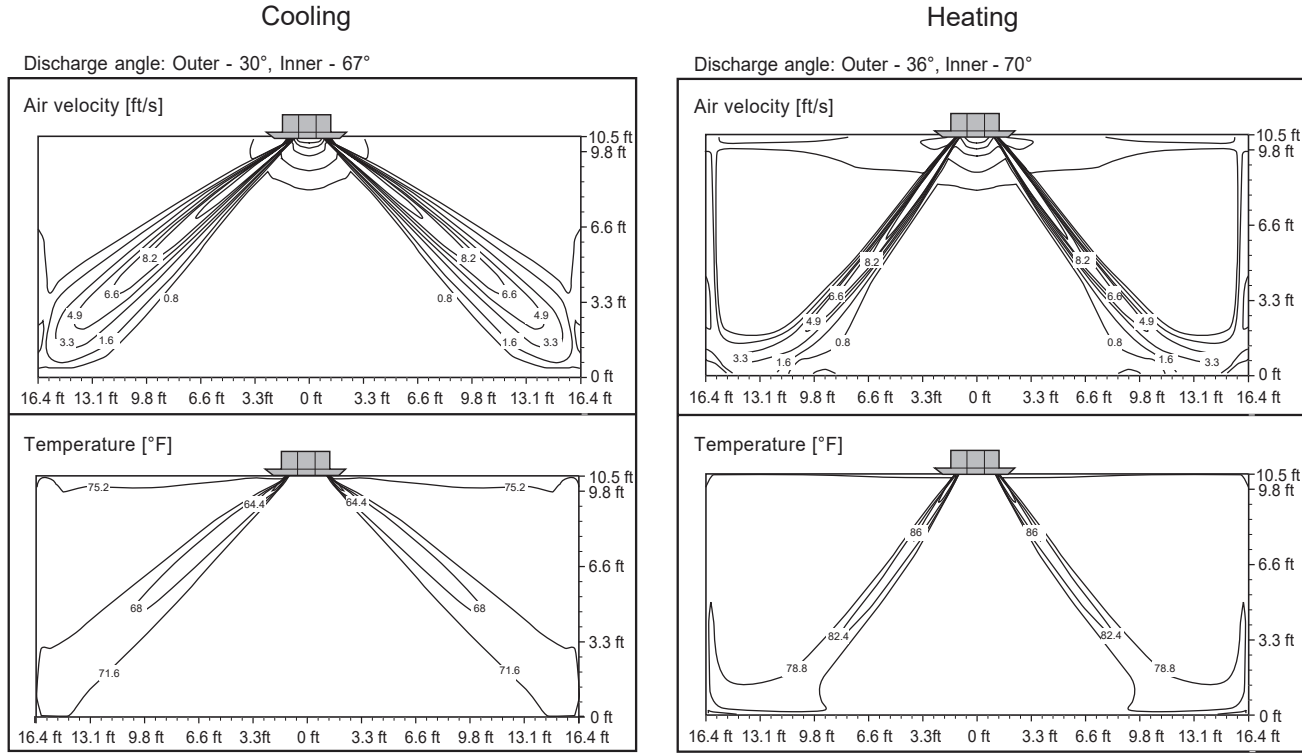
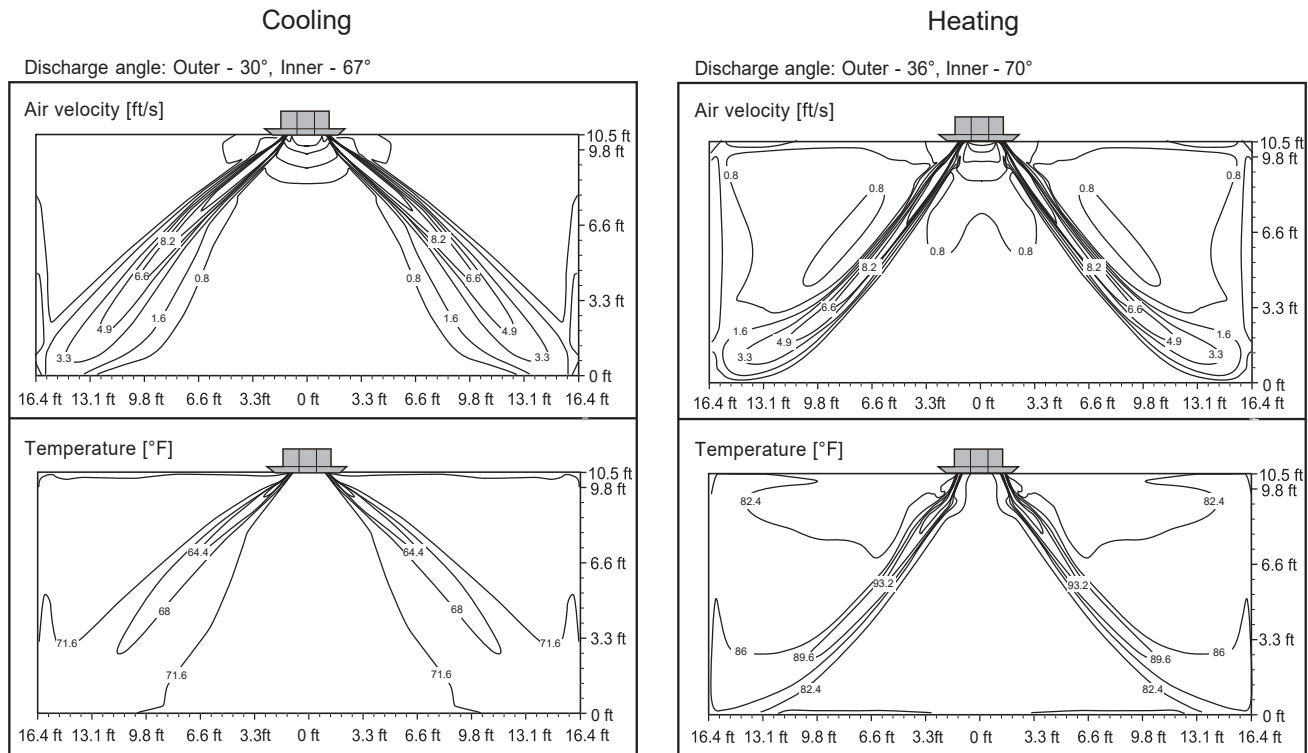

Figure 37: LCN429HV, LCN489HV Air Velocity and Temperature Distribution Charts.



LG Monitoring View (LGMV) Diagnostic Software and Cable

LGMV software allows the service technician or commissioning agent to connect a computer USB port to the outdoor unit main printed circuit board (PCB) using an accessory cable without the need for a separate interface device. The main screen for LGMV allows user to view the following real time data on one screen:

- Actual inverter compressor speed
- Target inverter compressor speed
- Actual outdoor fan speed
- Target outdoor unit fan speed
- Actual superheat
- Target superheat
- Actual subcooler circuit superheat
- Target subcooler circuit superheat
- Main EEV position
- Subcooling EEV position
- Inverter compressor current transducer value
- Outdoor air temperature
- Actual high pressure/saturation temperature
- Actual low pressure/saturation temperature
- Suction temperature
- Inverter compressor discharge temperature
- Constant speed compressor discharge temperature
- temperature
- Front outdoor coil pipe temperature
- Back outdoor coil pipe temperature
- Liquid line pipe temperature
- Subcooler inlet temperature
- Subcooler outlet temperature
- Average indoor unit (IDU) pipe temperature
- Inverter compressor operation indicator light
- Four-way reversing valve operation indicator light
- Pressure graph showing actual low pressure and actual high pressure levels
- Error code display
- Operating mode indicator
- Target high pressure
- Target low pressure
- PCB (printed circuit board) version
- Software version
- Installer name
- Model no. of outdoor units
- Site name
- Total number of connected indoor units
- Communication indicator lights
- Indoor unit capacity
- Indoor unit operating mode
- Indoor unit fan speed
- Indoor unit EEV position
- Indoor unit room temperature
- Indoor unit inlet pipe temperature
- Indoor unit outlet pipe temperature
- Indoor unit error code



Additional screens can be accessed by tabs on the main screen:

1. Cycleview: Graphic of internal components including:
 - Compressors showing actual speeds
 - EEVs
 - Indoor Units
 - Liquid injection valves
 - Temperature and pressure sensors
 - Four-way reversing valve
 - Outdoor fans showing status and speeds
2. Graph: Full screen graph of actual high and low pressures and high and low pressure limits. A sliding bar enables user to go back in time and view data.
3. Control IDU: Enables user to turn on all IDU's default setpoints of 86°F in heat mode or 64°F in cool mode.
4. Setting: Converts metric values to imperial values.
5. Making Data: Recording of real time data to a separate file created to be stored on the user's computer.
6. Loading Data: Recorded data from a saved ".CSV" file can be loaded to create an LGMV session.
7. Electrical Data: The lower half of main screen is changed to show the following:
 - Inverter compressor
 - Amps
 - Volts
 - Power Hz
 - Inverter control board fan Hz
 - Constant compressor
 - Current transducer value
 - Phase

Figure 38: Sample Cycleview.

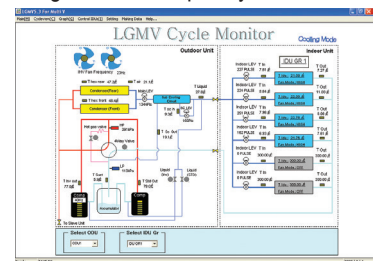

In lieu of connecting to the outdoor unit, user has the option to connect to the indoor unit with the use of a USB to RS-485 connector kit. When connected through the indoor unit, user will not be able to record data.

This software can be used to both commission new systems and troubleshoot existing systems. LGMV data can be recorded to a ".CSV" file and emailed to an LG representative to assist with diagnostic evaluations.

Recommended Minimum PC Configuration:

- CPU: Pentium® IV 1.6 GHz
- Operating System: Windows® NT/2000/XP/Vista
- Main Memory: 256 MB
- Hard Disk: 600 MB when operating
- Web Browser: Internet Explorer® 5.0

LGMV is available in different formats, including Mobile LGMV, which is a app for use on wireless devices. Contact your LG Sales Representative for more information.

LG Smart Inverter Monitoring System (SIMS)

SIMS can be used to display and graph operational data for single zone systems and respective components (indoor unit and outdoor unit). SIMS also displays error codes and a troubleshooting guide. SIMS consists of a hardware Wireless Local Area Network (WLAN) module, an interface cable, and a free downloadable application (app) for iOS® or Android™. The user must supply either an Apple® or an Android smart phone; SIMS is not optimized for tablets, and only be used with LG single zone and Multi F systems.

Only trained HVAC service technicians familiar with variable refrigerant flow (VRF) systems in general and with LG's single zone and multi zone products can use SIMS. The technician must understand inverter air conditioning operation cycles, the meaning of the data displayed by SIMS, and how to use the data to troubleshoot the system.

iOS is a registered trademark of Cisco in the U.S. and other countries. Android is a trademark of Google Inc. Apple is a trademark of Apple Inc., registered in the U.S. and other countries.

Contact your LG Sales Representative for system requirements, the latest version of SIMS, how to download the app, or other information.

Figure 39: LG SIMS WLAN Module.



Four-Way Ceiling-Cassette Accessories Overview

Table 24: Four-Way Ceiling-Cassette Accessories Overview.

Model No.	Description
ZLABGP04A	Low Ambient Wind Baffle for 18k and 24k Outdoor Units (One [1] Required), 36k, 42k and 48k Outdoor Units (Two [2] Required)
PT-QCHW0 / PT-UQC	Ceiling Grilles for 2' x 2' Indoor Units
PTDCQ	Decorative Cover for 2' x 2' Indoor Unit (Can Only Be Used with the PT-UQC Ceiling Grille)
PT-AAGW0	Ceiling Grilles for 3' x 3' Indoor Units
PTVK430	Outside Air Flange for All Capacities (Must comply with applicable codes for fire isolation dampers.)
PRARH1	Auxiliary Heat Relay Kit for All Capacities
PMNFP14A1	PI-485 for All Capacities
PAHCMR000	AHU Communication Kit for All Capacities
PWFMD200	Wi-Fi Module for All Capacities

PERFORMANCE DATA

Cooling Capacity Data on page 43

Maximum Cooling Capacity Data on page 48

Heating Capacity Data on page 53

Maximum Heating Capacity Data on page 56

Equipment Selection Procedure on page 59

Cooling Capacity Table for LC188HHV4 (LCN188HV4 + LUU180HHV)

Table 25: LCN188HHV4 / LUU180HHV Cooling Capacities.

Outdoor Air Temp. (°F DB)	Indoor Air Temp. °F DB / °F WB																	
	68 / 57			73 / 61			77 / 64			80 / 67			86 / 72			90 / 75		
	TC	SHC	PI	TC	SHC	PI	TC	SHC	PI	TC	SHC	PI	TC	SHC	PI	TC	SHC	PI
-4	17.70	12.52	0.83	18.80	13.22	0.86	19.89	12.80	0.90	20.69	13.07	0.91	22.09	13.18	0.92	23.19	13.43	0.94
-0.4	17.69	12.59	0.84	18.79	13.30	0.87	19.88	12.88	0.91	20.68	13.15	0.92	22.08	13.26	0.93	23.18	13.51	0.95
5	17.67	12.70	0.86	18.77	13.42	0.89	19.87	12.99	0.92	20.66	13.26	0.93	22.06	13.38	0.95	23.16	13.63	0.97
10	17.66	12.80	0.87	18.76	13.52	0.90	19.85	13.09	0.93	20.64	13.37	0.95	22.05	13.48	0.96	23.14	13.74	0.98
15	17.65	12.90	0.88	18.74	13.63	0.91	19.84	13.20	0.95	20.63	13.47	0.96	22.03	13.59	0.98	23.12	13.85	1.00
20	17.63	13.00	0.90	18.73	13.74	0.93	19.82	13.30	0.96	20.61	13.58	0.97	22.01	13.69	0.99	23.11	13.95	1.01
25	17.62	13.10	0.91	18.71	13.84	0.94	19.81	13.40	0.98	20.60	13.69	0.99	22.00	13.80	1.00	23.09	14.06	1.03
30	17.60	13.20	0.92	18.70	13.95	0.95	19.79	13.51	0.99	20.58	13.79	1.00	21.98	13.91	1.02	23.07	14.17	1.04
35	17.59	13.30	0.93	18.68	14.05	0.97	19.78	13.61	1.00	20.57	13.90	1.01	21.96	14.01	1.03	23.05	14.28	1.05
40	17.58	13.41	0.95	18.67	14.16	0.98	19.76	13.71	1.02	20.55	14.00	1.03	21.94	14.12	1.05	23.04	14.39	1.07
45	17.56	13.51	0.96	18.66	14.27	0.99	19.75	13.81	1.03	20.53	14.10	1.04	21.93	14.22	1.06	23.02	14.49	1.08
50	17.55	13.60	0.97	18.64	14.37	1.01	19.73	13.92	1.04	20.52	14.21	1.06	21.91	14.33	1.08	23.00	14.60	1.10
55	17.54	13.70	0.98	18.63	14.48	1.02	19.72	14.02	1.06	20.50	14.31	1.07	21.89	14.43	1.09	22.98	14.71	1.11
60	17.52	13.80	1.00	18.61	14.58	1.03	19.70	14.12	1.07	20.49	14.42	1.08	21.88	14.54	1.10	22.97	14.81	1.13
65	17.51	13.90	1.01	18.60	14.69	1.05	19.69	14.22	1.08	20.47	14.52	1.10	21.86	14.64	1.12	22.95	14.92	1.14
70	17.50	14.00	1.02	18.58	14.79	1.06	19.67	14.32	1.10	20.46	14.62	1.11	21.84	14.75	1.13	22.93	15.03	1.15
75	17.08	13.77	1.08	18.16	14.57	1.12	19.24	14.12	1.16	20.03	14.43	1.17	21.41	14.57	1.19	22.50	14.86	1.22
80	16.66	13.54	1.13	17.74	14.34	1.17	18.82	13.91	1.22	19.60	14.23	1.23	20.98	14.38	1.25	22.06	14.68	1.28
85	16.24	13.29	1.19	17.32	14.10	1.23	18.40	13.70	1.28	19.17	14.02	1.29	20.55	14.19	1.31	21.63	14.50	1.34
90	15.82	13.04	1.24	16.90	13.85	1.29	17.97	13.48	1.33	18.75	13.80	1.35	20.12	13.99	1.38	21.20	14.31	1.40
95	15.37	12.90	1.30	16.44	13.73	1.34	17.51	13.37	1.39	18.00	13.50	1.41	19.65	13.92	1.44	20.72	14.24	1.47
100	14.99	12.56	1.35	16.06	13.38	1.40	17.13	13.05	1.45	17.77	13.29	1.47	19.28	13.62	1.50	20.35	13.95	1.53
105	14.62	12.21	1.41	15.69	13.03	1.46	16.76	12.74	1.51	17.53	13.08	1.53	18.90	13.32	1.56	19.97	13.66	1.59
110	14.24	11.79	1.46	15.32	12.61	1.52	16.39	12.34	1.57	17.16	12.69	1.59	18.53	12.94	1.62	19.60	13.29	1.65
115	13.87	11.44	1.52	14.94	12.26	1.57	16.01	12.02	1.63	16.79	12.37	1.65	18.15	12.63	1.68	19.22	12.98	1.71
118	13.65	11.36	1.55	14.72	12.18	1.61	15.79	11.95	1.67	16.56	12.31	1.69	17.93	12.59	1.72	19.00	12.95	1.75
122	13.57	11.33	1.60	14.64	12.16	1.65	15.71	11.93	1.71	16.49	12.29	1.73	17.85	12.57	1.77	18.92	12.94	1.80

Performance Data

DB: Dry Bulb Temperature (°F) WB: Wet Bulb Temperature (°F) TC: Total Capacity (kBtu/h)
SHC: Sensible Capacity (kBtu/h) PI: Power Input (kW) (includes compressor, indoor fan motor and outdoor fan motor)

1. All capacities are net, evaporator fan motor heat is deducted.
2. Cooling range can be extended from 5°F down to -4°F using the Low Ambient Wind Baffle Kit (sold separately).
3. Grey shading indicates reference data. When operating at this temperature, these values can be different if the system is not running consistently.

4. Direct interpolation is permissible. ☹ Do not extrapolate.
Capacity as rated: 0 ft. above sea level with 24.6 ft. of refrigerant piping, 0 ft. level difference between outdoor and indoor units.
Cooling capacity rating obtained with air entering the indoor unit at 80°F dry bulb (DB) and 67°F wet bulb (WB), and outdoor ambient conditions of 95°F dry bulb (DB) and 75°F wet bulb (WB).

PERFORMANCE DATA



Cooling Capacity

LC249HHV

Cooling Capacity Table for LC249HHV (LCN249HV + LUU240HHV)

Table 26: LCN249HV / LUU240HHV Cooling Capacities.

Outdoor Air Temp. (°F DB)	Indoor Air Temp. °F DB / °F WB																	
	68 / 57			73 / 61			77 / 64			80 / 67			86 / 72			90 / 75		
	TC	SHC	PI	TC	SHC	PI	TC	SHC	PI	TC	SHC	PI	TC	SHC	PI	TC	SHC	PI
-4	23.60	18.25	1.13	25.06	19.28	1.17	26.53	18.66	1.21	27.58	19.06	1.22	29.46	19.22	1.25	30.92	19.58	1.27
-0.4	23.58	18.35	1.14	25.05	19.39	1.18	26.51	18.77	1.22	27.57	19.17	1.24	29.44	19.33	1.26	30.91	19.70	1.29
5	23.56	18.51	1.16	25.03	19.56	1.20	26.49	18.94	1.24	27.55	19.34	1.26	29.42	19.50	1.28	30.88	19.87	1.31
10	23.55	18.66	1.18	25.01	19.71	1.22	26.47	19.09	1.26	27.53	19.49	1.28	29.39	19.65	1.30	30.86	20.03	1.33
15	23.53	18.81	1.19	24.99	19.87	1.24	26.45	19.24	1.28	27.50	19.64	1.30	29.37	19.81	1.32	30.83	20.18	1.35
20	23.51	18.96	1.21	24.97	20.02	1.25	26.43	19.39	1.30	27.48	19.80	1.31	29.35	19.96	1.34	30.81	20.34	1.37
25	23.49	19.10	1.23	24.95	20.18	1.27	26.41	19.54	1.32	27.46	19.95	1.33	29.33	20.12	1.36	30.79	20.50	1.39
30	23.47	19.25	1.24	24.93	20.33	1.29	26.39	19.69	1.34	27.44	20.10	1.35	29.30	20.27	1.38	30.76	20.66	1.40
35	23.46	19.40	1.26	24.91	20.49	1.31	26.37	19.84	1.35	27.42	20.26	1.37	29.28	20.43	1.40	30.74	20.81	1.42
40	23.44	19.54	1.28	24.89	20.64	1.32	26.35	19.99	1.37	27.40	20.41	1.39	29.26	20.58	1.41	30.72	20.97	1.44
45	23.42	19.69	1.29	24.87	20.80	1.34	26.33	20.14	1.39	27.38	20.56	1.41	29.24	20.73	1.43	30.69	21.13	1.46
50	23.40	19.83	1.31	24.85	20.95	1.36	26.31	20.29	1.41	27.36	20.71	1.43	29.21	20.89	1.45	30.67	21.28	1.48
55	23.38	19.98	1.33	24.84	21.10	1.38	26.29	20.43	1.43	27.34	20.86	1.44	29.19	21.04	1.47	30.64	21.44	1.50
60	23.37	20.12	1.35	24.82	21.26	1.40	26.27	20.58	1.45	27.32	21.02	1.46	29.17	21.19	1.49	30.62	21.59	1.52
65	23.35	20.27	1.36	24.80	21.41	1.41	26.25	20.73	1.46	27.29	21.17	1.48	29.15	21.35	1.51	30.60	21.75	1.54
70	23.33	20.41	1.38	24.78	21.56	1.43	26.23	20.88	1.48	27.27	21.32	1.50	29.13	21.50	1.53	30.57	21.91	1.56
75	22.77	20.08	1.46	24.21	21.24	1.51	25.66	20.59	1.56	26.70	21.03	1.58	28.55	21.24	1.61	29.99	21.66	1.64
80	22.21	19.73	1.53	23.65	20.90	1.59	25.09	20.28	1.64	26.13	20.74	1.66	27.97	20.97	1.69	29.42	21.40	1.73
85	21.65	19.37	1.60	23.09	20.55	1.66	24.53	19.97	1.72	25.57	20.44	1.74	27.40	20.69	1.78	28.84	21.13	1.81
90	21.09	19.01	1.68	22.53	20.19	1.74	23.96	19.65	1.80	25.00	20.12	1.82	26.83	20.40	1.86	28.27	20.86	1.90
95	20.49	18.81	1.75	21.92	20.01	1.82	23.35	19.50	1.88	24.00	19.68	1.91	26.20	20.29	1.94	27.63	20.77	1.98
100	19.99	18.30	1.83	21.42	19.50	1.89	22.85	19.03	1.96	23.69	19.38	1.99	25.70	19.85	2.02	27.13	20.34	2.06
105	19.49	17.80	1.90	20.92	19.00	1.97	22.35	18.57	2.04	23.38	19.07	2.07	25.20	19.42	2.11	26.63	19.91	2.15
110	18.99	17.19	1.98	20.42	18.38	2.05	21.85	17.99	2.12	22.88	18.50	2.15	24.70	18.86	2.19	26.13	19.37	2.23
115	18.49	16.68	2.05	19.92	17.87	2.13	21.35	17.52	2.20	22.38	18.03	2.23	24.20	18.41	2.27	25.63	18.93	2.32
118	18.19	16.56	2.10	19.62	17.76	2.17	21.05	17.43	2.25	22.08	17.95	2.28	23.90	18.35	2.32	25.33	18.88	2.37
122	18.10	16.52	2.16	19.52	17.72	2.23	20.95	17.40	2.32	21.98	17.92	2.34	23.81	18.33	2.39	25.23	18.86	2.43

DB: Dry Bulb Temperature (°F) WB: Wet Bulb Temperature (°F) TC: Total Capacity (kBtu/h)
 SHC: Sensible Capacity (kBtu/h) PI: Power Input (kW) (includes compressor, indoor fan motor and outdoor fan motor)

1. All capacities are net, evaporator fan motor heat is deducted.
2. Cooling range can be extended from 5°F down to -4°F using the Low Ambient Wind Baffle Kit (sold separately).
3. Grey shading indicates reference data. When operating at this temperature, these values can be different if the system is not running consistently.

4. Direct interpolation is permissible. ⚠ Do not extrapolate.

Capacity as rated: 0 ft. above sea level with 24.6 ft. of refrigerant piping. 0 ft. level difference between outdoor and indoor units.

Cooling capacity rating obtained with air entering the indoor unit at 80°F dry bulb (DB) and 67°F wet bulb (WB), and outdoor ambient conditions of 95°F dry bulb (DB) and 75°F wet bulb (WB).



Cooling Capacity Table for LC369HHV (LCN369HV + LUU360HHV)

Table 27: LCN369HV / LUU360HHV Cooling Capacities.

Outdoor Air Temp. (°F DB)	Indoor Air Temp. °F DB / °F WB																	
	68 / 57			73 / 61			77 / 64			80 / 67			86 / 72			90 / 75		
	TC	SHC	PI	TC	SHC	PI	TC	SHC	PI	TC	SHC	PI	TC	SHC	PI	TC	SHC	PI
-4	35.39	26.04	1.69	37.59	27.50	1.75	39.79	26.63	1.82	41.38	27.19	1.84	44.19	27.42	1.87	46.38	27.94	1.91
-0.4	35.37	26.19	1.71	37.57	27.66	1.77	39.77	26.79	1.84	41.35	27.35	1.86	44.16	27.58	1.89	46.36	28.10	1.93
5	35.34	26.42	1.74	37.54	27.91	1.80	39.73	27.02	1.87	41.32	27.59	1.89	44.12	27.82	1.92	46.32	28.35	1.96
10	35.32	26.63	1.76	37.51	28.13	1.83	39.70	27.24	1.90	41.29	27.81	1.92	44.09	28.04	1.95	46.28	28.57	1.99
15	35.29	26.84	1.79	37.48	28.35	1.86	39.67	27.45	1.92	41.26	28.03	1.95	44.06	28.26	1.98	46.25	28.80	2.02
20	35.26	27.05	1.82	37.45	28.57	1.88	39.64	27.66	1.95	41.23	28.25	1.97	44.02	28.49	2.01	46.21	29.02	2.05
25	35.24	27.26	1.84	37.43	28.79	1.91	39.61	27.88	1.98	41.19	28.47	2.00	43.99	28.71	2.04	46.18	29.25	2.08
30	35.21	27.47	1.87	37.40	29.01	1.94	39.58	28.09	2.01	41.16	28.68	2.03	43.96	28.93	2.07	46.14	29.47	2.11
35	35.18	27.67	1.89	37.37	29.23	1.96	39.55	28.31	2.03	41.13	28.90	2.06	43.92	29.15	2.10	46.11	29.70	2.14
40	35.16	27.88	1.92	37.34	29.45	1.99	39.52	28.52	2.06	41.10	29.12	2.08	43.89	29.37	2.12	46.07	29.92	2.17
45	35.13	28.09	1.94	37.31	29.67	2.02	39.49	28.73	2.09	41.07	29.34	2.11	43.86	29.58	2.15	46.04	30.14	2.20
50	35.10	28.30	1.97	37.28	29.89	2.04	39.46	28.94	2.12	41.04	29.55	2.14	43.82	29.80	2.18	46.00	30.37	2.22
55	35.08	28.51	2.00	37.25	30.11	2.07	39.43	29.16	2.14	41.01	29.77	2.17	43.79	30.02	2.21	45.97	30.59	2.25
60	35.05	28.71	2.02	37.23	30.33	2.10	39.40	29.37	2.17	40.97	29.99	2.20	43.76	30.24	2.24	45.93	30.81	2.28
65	35.02	28.92	2.05	37.20	30.55	2.12	39.37	29.58	2.20	40.94	30.20	2.22	43.72	30.46	2.27	45.90	31.03	2.31
70	34.99	29.13	2.07	37.17	30.77	2.15	39.34	29.79	2.23	40.91	30.42	2.25	43.69	30.67	2.29	45.86	31.26	2.34
75	34.15	28.65	2.18	36.32	30.30	2.26	38.49	29.37	2.35	40.05	30.01	2.37	42.82	30.30	2.42	44.99	30.90	2.47
80	33.31	28.16	2.30	35.47	29.82	2.38	37.64	28.94	2.47	39.20	29.60	2.50	41.96	29.92	2.54	44.12	30.54	2.59
85	32.48	27.64	2.41	34.63	29.32	2.50	36.79	28.49	2.59	38.35	29.16	2.62	41.10	29.52	2.67	43.26	30.15	2.72
90	31.64	27.12	2.52	33.79	28.81	2.61	35.94	28.03	2.71	37.50	28.71	2.74	40.25	29.10	2.79	42.40	29.76	2.85
95	30.74	26.84	2.63	32.88	28.55	2.73	35.02	27.82	2.83	36.00	28.08	2.86	39.30	28.95	2.91	41.44	29.63	2.97
100	29.99	26.12	2.74	32.13	27.83	2.84	34.27	27.15	2.95	35.53	27.65	2.98	38.55	28.32	3.04	40.69	29.02	3.10
105	29.24	25.40	2.86	31.38	27.11	2.96	33.52	26.49	3.07	35.07	27.21	3.10	37.80	27.70	3.16	39.94	28.41	3.22
110	28.49	24.53	2.97	30.63	26.23	3.08	32.77	25.67	3.19	34.32	26.40	3.22	37.05	26.92	3.28	39.20	27.64	3.35
115	27.74	23.80	3.08	29.88	25.49	3.19	32.02	24.99	3.31	33.57	25.72	3.35	36.31	26.27	3.41	38.45	27.01	3.48
118	27.29	23.62	3.15	29.43	25.34	3.26	31.57	24.87	3.38	33.12	25.61	3.42	35.86	26.18	3.48	38.00	26.93	3.55
122	27.14	23.56	3.24	29.28	25.29	3.35	31.43	24.82	3.48	32.97	25.57	3.52	35.71	26.15	3.58	37.85	26.91	3.65

Performance Data

DB: Dry Bulb Temperature (°F) WB: Wet Bulb Temperature (°F) TC: Total Capacity (kBtu/h)
SHC: Sensible Capacity (kBtu/h) PI: Power Input (kW) (includes compressor, indoor fan motor and outdoor fan motor)

1. All capacities are net, evaporator fan motor heat is deducted.
2. Cooling range can be extended from 5°F down to -4°F using the Low Ambient Wind Baffle Kit (sold separately).
3. Grey shading indicates reference data. When operating at this temperature, these values can be different if the system is not running consistently.

4. Direct interpolation is permissible. ☹ Do not extrapolate.
Capacity as rated: 0 ft. above sea level with 24.6 ft. of refrigerant piping. 0 ft. level difference between outdoor and indoor units.
Cooling capacity rating obtained with air entering the indoor unit at 80°F dry bulb (DB) and 67°F wet bulb (WB), and outdoor ambient conditions of 95°F dry bulb (DB) and 75°F wet bulb (WB).

PERFORMANCE DATA



Cooling Capacity

LC429HHV

Cooling Capacity Table for LC429HHV (LCN429HV + LUU420HHV)

Table 28: LCN429HV / LUU420HHV Cooling Capacities.

Outdoor Air Temp. (°F DB)	Indoor Air Temp. °F DB / °F WB																	
	68 / 57			73 / 61			77 / 64			80 / 67			86 / 72			90 / 75		
	TC	SHC	PI	TC	SHC	PI	TC	SHC	PI	TC	SHC	PI	TC	SHC	PI	TC	SHC	PI
-4	41.29	31.54	1.94	43.86	33.32	2.01	46.42	32.26	2.08	48.27	32.94	2.11	51.55	33.22	2.15	54.11	33.85	2.19
-0.4	41.27	31.73	1.96	43.83	33.52	2.03	46.40	32.45	2.11	48.25	33.14	2.13	51.52	33.42	2.17	54.08	34.05	2.22
5	41.24	32.00	1.99	43.80	33.81	2.07	46.36	32.74	2.14	48.21	33.42	2.17	51.48	33.71	2.21	54.04	34.34	2.25
10	41.20	32.26	2.02	43.76	34.08	2.10	46.32	33.00	2.17	48.17	33.69	2.20	51.44	33.98	2.24	54.00	34.62	2.28
15	41.17	32.51	2.05	43.73	34.35	2.13	46.29	33.26	2.21	48.13	33.96	2.23	51.40	34.24	2.27	53.96	34.89	2.32
20	41.14	32.77	2.08	43.70	34.62	2.16	46.25	33.52	2.24	48.10	34.22	2.26	51.36	34.51	2.31	53.92	35.16	2.35
25	41.11	33.02	2.11	43.66	34.88	2.19	46.22	33.78	2.27	48.06	34.49	2.29	51.32	34.78	2.34	53.88	35.44	2.38
30	41.08	33.28	2.14	43.63	35.15	2.22	46.18	34.04	2.30	48.02	34.75	2.33	51.28	35.04	2.37	53.83	35.71	2.42
35	41.05	33.53	2.17	43.60	35.42	2.25	46.15	34.29	2.33	47.99	35.02	2.36	51.24	35.31	2.40	53.79	35.98	2.45
40	41.02	33.78	2.20	43.56	35.68	2.28	46.11	34.55	2.36	47.95	35.28	2.39	51.20	35.58	2.44	53.75	36.25	2.48
45	40.98	34.03	2.23	43.53	35.95	2.31	46.07	34.81	2.40	47.91	35.54	2.42	51.17	35.84	2.47	53.71	36.52	2.52
50	40.95	34.28	2.26	43.50	36.22	2.34	46.04	35.07	2.43	47.88	35.81	2.45	51.13	36.11	2.50	53.67	36.79	2.55
55	40.92	34.54	2.29	43.46	36.48	2.37	46.00	35.32	2.46	47.84	36.07	2.49	51.09	36.37	2.53	53.63	37.06	2.58
60	40.89	34.79	2.32	43.43	36.75	2.40	45.97	35.58	2.49	47.80	36.33	2.52	51.05	36.64	2.57	53.59	37.33	2.62
65	40.86	35.04	2.35	43.40	37.01	2.43	45.93	35.84	2.52	47.77	36.59	2.55	51.01	36.90	2.60	53.55	37.60	2.65
70	40.83	35.29	2.38	43.36	37.28	2.46	45.90	36.09	2.55	47.73	36.85	2.58	50.97	37.16	2.63	53.50	37.87	2.68
75	39.84	34.71	2.51	42.37	36.71	2.60	44.90	35.59	2.69	46.73	36.36	2.72	49.96	36.71	2.77	52.49	37.44	2.83
80	38.86	34.11	2.63	41.39	36.13	2.73	43.91	35.07	2.83	45.73	35.86	2.86	48.95	36.25	2.92	51.48	37.00	2.97
85	37.89	33.49	2.76	40.41	35.52	2.86	42.92	34.52	2.97	44.74	35.33	3.00	47.96	35.76	3.06	50.47	36.53	3.12
90	36.91	32.86	2.89	39.43	34.90	3.00	41.94	33.96	3.10	43.75	34.79	3.14	46.96	35.26	3.20	49.47	36.05	3.26
95	35.86	32.51	3.02	38.36	34.59	3.13	40.85	33.70	3.24	42.00	34.02	3.28	45.85	35.07	3.34	48.35	35.90	3.41
100	34.98	31.64	3.15	37.48	33.72	3.26	39.98	32.90	3.38	41.46	33.49	3.42	44.98	34.32	3.48	47.47	35.16	3.55
105	34.11	30.77	3.27	36.61	32.85	3.39	39.11	32.10	3.52	40.91	32.97	3.56	44.10	33.56	3.63	46.60	34.42	3.70
110	33.24	29.72	3.40	35.74	31.78	3.53	38.23	31.10	3.66	40.04	31.98	3.70	43.23	32.61	3.77	45.73	33.48	3.84
115	32.37	28.83	3.53	34.86	30.89	3.66	37.36	30.28	3.79	39.17	31.17	3.84	42.36	31.83	3.91	44.86	32.72	3.99
118	31.84	28.62	3.61	34.34	30.70	3.74	36.84	30.13	3.88	38.64	31.03	3.92	41.83	31.72	3.99	44.33	32.63	4.07
122	31.67	28.55	3.71	34.16	30.64	3.85	36.66	30.07	3.99	38.47	30.98	4.03	41.66	31.68	4.11	44.16	32.60	4.19

DB: Dry Bulb Temperature (°F) WB: Wet Bulb Temperature (°F) TC: Total Capacity (kBtu/h)
 SHC: Sensible Capacity (kBtu/h) PI: Power Input (kW) (includes compressor, indoor fan motor and outdoor fan motor)

- All capacities are net, evaporator fan motor heat is deducted.
- Cooling range can be extended from 5°F down to -4°F using the Low Ambient Wind Baffle Kit (sold separately).
- Grey shading indicates reference data. When operating at this temperature, these values can be different if the system is not running consistently.

4. Direct interpolation is permissible. ⚠ Do not extrapolate.

Capacity as rated: 0 ft. above sea level with 24.6 ft. of refrigerant piping. 0 ft. level difference between outdoor and indoor units.

Cooling capacity rating obtained with air entering the indoor unit at 80°F dry bulb (DB) and 67°F wet bulb (WB), and outdoor ambient conditions of 95°F dry bulb (DB) and 75°F wet bulb (WB).



Cooling Capacity Table for LC489HHV (LCN489HV + LUU480HHV)

Table 29: LCN489HV / LUU480HHV Cooling Capacities.

Outdoor Air Temp. (°F DB)	Indoor Air Temp. °F DB / °F WB																	
	68 / 57			73 / 61			77 / 64			80 / 67			86 / 72			90 / 75		
	TC	SHC	PI	TC	SHC	PI	TC	SHC	PI	TC	SHC	PI	TC	SHC	PI	TC	SHC	PI
-4	47.19	34.27	2.27	50.12	36.20	2.35	53.05	35.05	2.44	55.17	35.79	2.47	58.91	36.09	2.52	61.84	36.78	2.57
-0.4	47.16	34.47	2.30	50.09	36.41	2.38	53.02	35.26	2.47	55.14	36.00	2.50	58.88	36.30	2.54	61.81	36.99	2.59
5	47.13	34.77	2.33	50.05	36.73	2.42	52.98	35.56	2.51	55.09	36.31	2.54	58.83	36.62	2.58	61.76	37.31	2.64
10	47.09	35.05	2.37	50.01	37.02	2.46	52.94	35.85	2.54	55.05	36.60	2.57	58.79	36.91	2.62	61.71	37.61	2.67
15	47.05	35.32	2.40	49.98	37.31	2.49	52.90	36.13	2.58	55.01	36.89	2.61	58.74	37.20	2.66	61.67	37.91	2.71
20	47.02	35.60	2.44	49.94	37.61	2.53	52.86	36.41	2.62	54.97	37.18	2.65	58.70	37.49	2.70	61.62	38.20	2.75
25	46.98	35.88	2.47	49.90	37.90	2.56	52.82	36.70	2.66	54.93	37.47	2.69	58.65	37.78	2.74	61.57	38.50	2.79
30	46.95	36.15	2.51	49.86	38.19	2.60	52.78	36.98	2.69	54.88	37.75	2.72	58.61	38.07	2.78	61.52	38.79	2.83
35	46.91	36.43	2.54	49.82	38.48	2.63	52.74	37.26	2.73	54.84	38.04	2.76	58.56	38.36	2.81	61.48	39.09	2.87
40	46.87	36.70	2.58	49.79	38.77	2.67	52.70	37.54	2.77	54.80	38.33	2.80	58.52	38.65	2.85	61.43	39.38	2.91
45	46.84	36.97	2.61	49.75	39.06	2.71	52.66	37.82	2.80	54.76	38.61	2.84	58.47	38.94	2.89	61.38	39.68	2.95
50	46.80	37.25	2.64	49.71	39.35	2.74	52.62	38.10	2.84	54.72	38.90	2.87	58.43	39.23	2.93	61.34	39.97	2.99
55	46.77	37.52	2.68	49.67	39.63	2.78	52.58	38.38	2.88	54.67	39.18	2.91	58.38	39.52	2.97	61.29	40.26	3.03
60	46.73	37.79	2.71	49.63	39.92	2.81	52.54	38.66	2.92	54.63	39.47	2.95	58.34	39.80	3.00	61.24	40.56	3.06
65	46.70	38.06	2.75	49.60	40.21	2.85	52.50	38.93	2.95	54.59	39.75	2.99	58.30	40.09	3.04	61.20	40.85	3.10
70	46.66	38.34	2.78	49.56	40.50	2.88	52.46	39.21	2.99	54.55	40.04	3.02	58.25	40.37	3.08	61.15	41.14	3.14
75	45.54	37.70	2.93	48.43	39.88	3.04	51.32	38.66	3.15	53.41	39.50	3.19	57.10	39.88	3.25	59.99	40.67	3.31
80	44.41	37.06	3.08	47.30	39.25	3.20	50.18	38.10	3.31	52.26	38.96	3.35	55.95	39.38	3.41	58.83	40.20	3.48
85	43.30	36.38	3.23	46.18	38.59	3.35	49.05	37.50	3.47	51.13	38.38	3.51	54.81	38.85	3.58	57.68	39.69	3.65
90	42.19	35.70	3.38	45.06	37.92	3.51	47.93	36.90	3.63	50.00	37.79	3.68	53.66	38.31	3.75	56.53	39.17	3.82
95	40.98	35.32	3.53	43.84	37.58	3.66	46.69	36.62	3.80	48.00	36.96	3.84	52.40	38.10	3.91	55.25	39.00	3.99
100	39.98	34.37	3.68	42.84	36.63	3.82	45.69	35.74	3.96	47.38	36.39	4.00	51.40	37.28	4.08	54.26	38.20	4.16
105	38.98	33.43	3.83	41.84	35.68	3.97	44.69	34.87	4.12	46.76	35.82	4.17	50.40	36.46	4.24	53.26	37.40	4.33
110	37.99	32.29	3.98	40.84	34.53	4.13	43.70	33.79	4.28	45.76	34.75	4.33	49.41	35.43	4.41	52.26	36.37	4.50
115	36.99	31.32	4.13	39.84	33.56	4.29	42.70	32.90	4.44	44.76	33.86	4.49	48.41	34.58	4.58	51.26	35.55	4.67
118	36.39	31.09	4.22	39.24	33.35	4.38	42.10	32.73	4.54	44.16	33.71	4.59	47.81	34.46	4.68	50.66	35.45	4.77
122	36.19	31.02	4.34	39.05	33.28	4.50	41.90	32.67	4.67	43.96	33.66	4.72	47.61	34.42	4.81	50.46	35.42	4.91

DB: Dry Bulb Temperature (°F) WB: Wet Bulb Temperature (°F) TC: Total Capacity (kBtu/h)
 SHC: Sensible Capacity (kBtu/h) PI: Power Input (kW) (includes compressor, indoor fan motor and outdoor fan motor)

- All capacities are net, evaporator fan motor heat is deducted.
- Cooling range can be extended from 5°F down to -4°F using the Low Ambient Wind Baffle Kit (sold separately).
- Grey shading indicates reference data. When operating at this temperature, these values can be different if the system is not running consistently.

4. Direct interpolation is permissible. ⊘ Do not extrapolate.

Capacity as rated: 0 ft. above sea level with 24.6 ft. of refrigerant piping, 0 ft. level difference between outdoor and indoor units.

Cooling capacity rating obtained with air entering the indoor unit at 80°F dry bulb (DB) and 67°F wet bulb (WB), and outdoor ambient conditions of 95°F dry bulb (DB) and 75°F wet bulb (WB).

PERFORMANCE DATA



Maximum Cooling Capacity

LC188HHV4

Maximum Cooling Capacity Table for LC188HHV4 (LCN188HV4 + LUU180HHV)

Table 30: LCN188HV4 / LUU180HHV Maximum Cooling Capacities.

Outdoor Air Temp. (°F DB)	Indoor Air Temp. °F DB / °F WB																	
	68 / 57			73 / 61			77 / 64			80 / 67			86 / 72			90 / 75		
	TC	SHC	PI	TC	SHC	PI	TC	SHC	PI	TC	SHC	PI	TC	SHC	PI	TC	SHC	PI
-4	24.38	16.10	1.69	25.90	17.00	1.75	27.41	16.46	1.81	28.50	16.81	1.83	30.44	16.95	1.87	31.95	17.27	1.90
-0.4	24.37	16.19	1.70	25.88	17.10	1.77	27.40	16.56	1.83	28.49	16.91	1.85	30.42	17.05	1.89	31.94	17.37	1.93
5	24.35	16.33	1.73	25.86	17.25	1.80	27.37	16.70	1.86	28.46	17.06	1.88	30.40	17.20	1.92	31.91	17.53	1.96
10	24.33	16.46	1.76	25.84	17.39	1.82	27.35	16.84	1.89	28.44	17.19	1.91	30.37	17.34	1.95	31.88	17.67	1.99
15	24.31	16.59	1.78	25.82	17.53	1.85	27.33	16.97	1.92	28.42	17.33	1.94	30.35	17.47	1.97	31.86	17.80	2.01
20	24.29	16.72	1.81	25.80	17.66	1.88	27.31	17.10	1.94	28.40	17.46	1.97	30.33	17.61	2.00	31.84	17.94	2.04
25	24.27	16.85	1.83	25.78	17.80	1.90	27.29	17.24	1.97	28.38	17.60	1.99	30.30	17.75	2.03	31.81	18.08	2.07
30	24.26	16.98	1.86	25.76	17.94	1.93	27.27	17.37	2.00	28.36	17.73	2.02	30.28	17.88	2.06	31.79	18.22	2.10
35	24.24	17.11	1.89	25.74	18.07	1.95	27.25	17.50	2.03	28.33	17.87	2.05	30.26	18.02	2.09	31.76	18.36	2.13
40	24.22	17.24	1.91	25.72	18.21	1.98	27.23	17.63	2.05	28.31	18.00	2.08	30.24	18.15	2.12	31.74	18.50	2.16
45	24.20	17.37	1.94	25.70	18.35	2.01	27.21	17.76	2.08	28.29	18.14	2.11	30.21	18.29	2.14	31.71	18.64	2.19
50	24.18	17.49	1.96	25.68	18.48	2.03	27.19	17.89	2.11	28.27	18.27	2.13	30.19	18.43	2.17	31.69	18.77	2.22
55	24.16	17.62	1.99	25.66	18.62	2.06	27.16	18.03	2.14	28.25	18.40	2.16	30.17	18.56	2.20	31.67	18.91	2.25
60	24.14	17.75	2.01	25.64	18.75	2.09	27.14	18.16	2.16	28.23	18.54	2.19	30.14	18.69	2.23	31.64	19.05	2.27
65	24.13	17.88	2.04	25.62	18.89	2.11	27.12	18.29	2.19	28.20	18.67	2.22	30.12	18.83	2.26	31.62	19.19	2.30
70	24.11	18.01	2.07	25.60	19.02	2.14	27.10	18.42	2.22	28.18	18.81	2.24	30.10	18.96	2.29	31.59	19.32	2.33
75	23.53	17.71	2.18	25.02	18.73	2.26	26.51	18.16	2.34	27.59	18.55	2.37	29.50	18.73	2.41	30.99	19.10	2.46
80	22.95	17.41	2.29	24.44	18.44	2.37	25.93	17.89	2.46	27.00	18.30	2.49	28.91	18.50	2.53	30.40	18.88	2.58
85	22.37	17.09	2.40	23.86	18.13	2.49	25.34	17.61	2.58	26.42	18.03	2.61	28.32	18.25	2.66	29.80	18.64	2.71
90	21.80	16.77	2.51	23.28	17.81	2.60	24.76	17.33	2.70	25.83	17.75	2.73	27.73	17.99	2.78	29.21	18.40	2.84
95	21.17	16.59	2.62	22.65	17.65	2.72	24.12	17.20	2.82	24.80	17.36	2.85	27.07	17.90	2.90	28.55	18.32	2.96
100	20.66	16.15	2.73	22.13	17.20	2.83	23.61	16.79	2.94	24.48	17.09	2.97	26.56	17.51	3.03	28.03	17.94	3.09
105	20.14	15.70	2.85	21.62	16.76	2.95	23.09	16.38	3.06	24.16	16.82	3.09	26.04	17.13	3.15	27.52	17.57	3.21
110	19.63	15.17	2.96	21.10	16.22	3.06	22.58	15.87	3.18	23.64	16.32	3.21	25.53	16.64	3.27	27.00	17.08	3.34
115	19.11	14.71	3.07	20.59	15.76	3.18	22.06	15.45	3.30	23.13	15.90	3.33	25.01	16.24	3.40	26.49	16.70	3.47
118	18.80	14.61	3.14	20.28	15.67	3.25	21.75	15.37	3.37	22.82	15.83	3.41	24.70	16.19	3.47	26.18	16.65	3.54
122	18.70	14.57	3.22	20.17	15.63	3.34	21.65	15.35	3.46	22.71	15.81	3.50	24.60	16.17	3.57	26.07	16.64	3.64

DB: Dry Bulb Temperature (°F) WB: Wet Bulb Temperature (°F) TC: Total Capacity (kBtu/h)

SHC: Sensible Capacity (kBtu/h) PI: Power Input (kW) (includes compressor, indoor fan motor and outdoor fan motor)

- All capacities are net, evaporator fan motor heat is deducted.
- Cooling range can be extended from 5°F down to -4°F using the Low Ambient Wind Baffle Kit (sold separately).
- Grey shading indicates reference data. When operating at this temperature, these values can be different if the system is not running consistently.

4. Direct interpolation is permissible. ⚠ Do not extrapolate.

Capacity as rated: 0 ft. above sea level with 24.6 ft. of refrigerant piping. 0 ft. level difference between outdoor and indoor units.

Maximum capacity based on full-load (maximum) compressor operation rather than part-load operation as published in rated capacity tables.



Maximum Cooling Capacity Table for LC249HHV (LCN249HV + LUU240HHV)

Table 31: LCN249HV / LUU240HHV Maximum Cooling Capacities.

Outdoor Air Temp. (°F DB)	Indoor Air Temp. °F DB / °F WB																	
	68 / 57			73 / 61			77 / 64			80 / 67			86 / 72			90 / 75		
	TC	SHC	PI	TC	SHC	PI	TC	SHC	PI	TC	SHC	PI	TC	SHC	PI	TC	SHC	PI
-4	29.49	19.47	1.77	31.33	20.57	1.84	33.16	19.92	1.91	34.48	20.34	1.93	36.82	20.51	1.96	38.65	20.90	2.00
-0.4	29.48	19.59	1.79	31.31	20.69	1.86	33.14	20.03	1.93	34.46	20.45	1.95	36.80	20.63	1.99	38.63	21.02	2.03
5	29.45	19.76	1.82	31.28	20.87	1.89	33.11	20.21	1.96	34.43	20.63	1.98	36.77	20.81	2.02	38.60	21.20	2.06
10	29.43	19.91	1.85	31.26	21.04	1.92	33.09	20.37	1.99	34.41	20.80	2.01	36.74	20.97	2.05	38.57	21.37	2.09
15	29.41	20.07	1.88	31.24	21.20	1.95	33.06	20.53	2.02	34.38	20.96	2.04	36.71	21.14	2.08	38.54	21.54	2.12
20	29.39	20.23	1.90	31.21	21.37	1.97	33.04	20.69	2.05	34.35	21.12	2.07	36.69	21.30	2.11	38.51	21.71	2.15
25	29.36	20.38	1.93	31.19	21.53	2.00	33.01	20.85	2.07	34.33	21.29	2.10	36.66	21.47	2.14	38.48	21.87	2.18
30	29.34	20.54	1.96	31.16	21.70	2.03	32.99	21.01	2.10	34.30	21.45	2.13	36.63	21.63	2.17	38.45	22.04	2.21
35	29.32	20.70	1.99	31.14	21.86	2.06	32.96	21.17	2.13	34.28	21.61	2.16	36.60	21.80	2.20	38.42	22.21	2.24
40	29.30	20.85	2.01	31.12	22.03	2.09	32.94	21.33	2.16	34.25	21.78	2.19	36.57	21.96	2.23	38.39	22.38	2.27
45	29.27	21.01	2.04	31.09	22.19	2.11	32.91	21.49	2.19	34.22	21.94	2.22	36.55	22.13	2.26	38.36	22.54	2.30
50	29.25	21.16	2.07	31.07	22.36	2.14	32.89	21.65	2.22	34.20	22.10	2.25	36.52	22.29	2.29	38.34	22.71	2.33
55	29.23	21.32	2.09	31.04	22.52	2.17	32.86	21.81	2.25	34.17	22.26	2.27	36.49	22.45	2.32	38.31	22.88	2.36
60	29.21	21.47	2.12	31.02	22.68	2.20	32.83	21.96	2.28	34.14	22.43	2.30	36.46	22.61	2.35	38.28	23.04	2.39
65	29.18	21.63	2.15	31.00	22.85	2.23	32.81	22.12	2.31	34.12	22.59	2.33	36.43	22.78	2.38	38.25	23.21	2.42
70	29.16	21.78	2.17	30.97	23.01	2.25	32.78	22.28	2.34	34.09	22.75	2.36	36.41	22.94	2.41	38.22	23.37	2.46
75	28.46	21.42	2.29	30.27	22.66	2.38	32.07	21.97	2.46	33.38	22.45	2.49	35.69	22.66	2.54	37.49	23.11	2.59
80	27.76	21.06	2.41	29.56	22.30	2.50	31.36	21.65	2.59	32.66	22.14	2.62	34.97	22.38	2.67	36.77	22.84	2.72
85	27.06	20.67	2.53	28.86	21.93	2.62	30.66	21.31	2.71	31.96	21.81	2.75	34.25	22.07	2.80	36.05	22.55	2.85
90	26.37	20.28	2.64	28.16	21.54	2.74	29.95	20.96	2.84	31.25	21.47	2.87	33.54	21.77	2.93	35.33	22.26	2.99
95	25.61	20.07	2.76	27.40	21.35	2.86	29.18	20.80	2.97	30.00	21.00	3.00	32.75	21.65	3.06	34.53	22.16	3.12
100	24.99	19.53	2.88	26.77	20.81	2.98	28.56	20.31	3.09	29.61	20.67	3.13	32.13	21.18	3.19	33.91	21.70	3.25
105	24.37	18.99	3.00	26.15	20.27	3.10	27.93	19.81	3.22	29.22	20.35	3.25	31.50	20.72	3.32	33.29	21.25	3.38
110	23.74	18.35	3.11	25.53	19.62	3.23	27.31	19.20	3.34	28.60	19.74	3.38	30.88	20.13	3.45	32.66	20.67	3.52
115	23.12	17.80	3.23	24.90	19.07	3.35	26.69	18.69	3.47	27.98	19.24	3.51	30.26	19.65	3.58	32.04	20.20	3.65
118	22.74	17.67	3.30	24.53	18.95	3.42	26.31	18.60	3.55	27.60	19.15	3.59	29.88	19.58	3.65	31.67	20.14	3.73
122	22.62	17.62	3.39	24.40	18.91	3.52	26.19	18.56	3.65	27.48	19.12	3.69	29.76	19.56	3.76	31.54	20.12	3.83

Performance Data

DB: Dry Bulb Temperature (°F) WB: Wet Bulb Temperature (°F) TC: Total Capacity (kBtu/h)
 SHC: Sensible Capacity (kBtu/h) PI: Power Input (kW) (includes compressor, indoor fan motor and outdoor fan motor)

1. All capacities are net, evaporator fan motor heat is deducted.
2. Cooling range can be extended from 5°F down to -4°F using the Low Ambient Wind Baffle Kit (sold separately).
3. Grey shading indicates reference data. When operating at this temperature, these values can be different if the system is not running consistently.

4. Direct interpolation is permissible. ⊘ Do not extrapolate.

Capacity as rated: 0 ft. above sea level with 24.6 ft. of refrigerant piping. 0 ft. level difference between outdoor and indoor units.

Maximum capacity based on full-load (maximum) compressor operation rather than part-load operation as published in rated capacity tables.

PERFORMANCE DATA



Maximum Cooling Capacity

LC369HHV

Maximum Cooling Capacity Table for LC369HHV (LCN369HV + LUU360HHV)

Table 32: LCN369HV / LUU360HHV Maximum Cooling Capacities.

Outdoor Air Temp. (°F DB)	Indoor Air Temp. °F DB / °F WB																	
	68 / 57			73 / 61			77 / 64			80 / 67			86 / 72			90 / 75		
	TC	SHC	PI	TC	SHC	PI	TC	SHC	PI	TC	SHC	PI	TC	SHC	PI	TC	SHC	PI
-4	45.22	31.14	3.20	48.03	32.89	3.32	50.84	31.85	3.44	52.87	32.52	3.48	56.46	32.79	3.54	59.27	33.41	3.61
-0.4	45.20	31.32	3.24	48.01	33.08	3.35	50.81	32.03	3.48	52.84	32.71	3.52	56.43	32.98	3.58	59.24	33.61	3.65
5	45.16	31.59	3.29	47.97	33.37	3.41	50.77	32.31	3.53	52.80	32.99	3.57	56.38	33.27	3.64	59.19	33.90	3.71
10	45.13	31.84	3.34	47.93	33.64	3.46	50.73	32.57	3.59	52.76	33.26	3.63	56.34	33.54	3.69	59.14	34.17	3.77
15	45.09	32.09	3.39	47.89	33.90	3.51	50.69	32.83	3.64	52.72	33.52	3.68	56.30	33.80	3.75	59.10	34.44	3.82
20	45.06	32.34	3.43	47.86	34.17	3.56	50.66	33.08	3.69	52.68	33.78	3.73	56.25	34.06	3.80	59.05	34.71	3.88
25	45.02	32.59	3.48	47.82	34.43	3.61	50.62	33.34	3.74	52.64	34.04	3.78	56.21	34.33	3.86	59.01	34.98	3.93
30	44.99	32.84	3.53	47.78	34.70	3.66	50.58	33.60	3.79	52.60	34.30	3.84	56.17	34.59	3.91	58.96	35.25	3.99
35	44.96	33.09	3.58	47.75	34.96	3.71	50.54	33.85	3.85	52.56	34.56	3.89	56.12	34.85	3.96	58.92	35.51	4.04
40	44.92	33.34	3.63	47.71	35.22	3.76	50.50	34.11	3.90	52.52	34.82	3.94	56.08	35.12	4.02	58.87	35.78	4.10
45	44.89	33.59	3.68	47.68	35.49	3.81	50.46	34.36	3.95	52.48	35.08	4.00	56.04	35.38	4.07	58.83	36.05	4.15
50	44.85	33.84	3.73	47.64	35.75	3.86	50.42	34.61	4.00	52.44	35.34	4.05	56.00	35.64	4.13	58.78	36.32	4.21
55	44.82	34.09	3.77	47.60	36.01	3.91	50.39	34.87	4.06	52.40	35.60	4.10	55.95	35.90	4.18	58.74	36.58	4.26
60	44.78	34.34	3.82	47.57	36.27	3.96	50.35	35.12	4.11	52.36	35.86	4.15	55.91	36.16	4.23	58.69	36.85	4.32
65	44.75	34.58	3.87	47.53	36.53	4.01	50.31	35.37	4.16	52.32	36.12	4.21	55.87	36.42	4.29	58.65	37.11	4.37
70	44.72	34.83	3.92	47.49	36.79	4.06	50.27	35.63	4.21	52.28	36.38	4.26	55.82	36.68	4.34	58.60	37.38	4.43
75	43.64	34.26	4.13	46.41	36.23	4.28	49.18	35.12	4.44	51.18	35.89	4.49	54.72	36.24	4.57	57.49	36.95	4.67
80	42.56	33.67	4.34	45.33	35.66	4.50	48.09	34.61	4.67	50.09	35.40	4.72	53.62	35.78	4.81	56.38	36.52	4.91
85	41.50	33.06	4.56	44.25	35.06	4.72	47.01	34.07	4.89	49.00	34.87	4.95	52.52	35.30	5.04	55.28	36.06	5.14
90	40.43	32.43	4.77	43.18	34.45	4.94	45.93	33.52	5.12	47.92	34.34	5.18	51.43	34.80	5.28	54.18	35.59	5.38
95	39.27	32.09	4.98	42.01	34.14	5.16	44.74	33.27	5.35	46.00	33.58	5.41	50.22	34.62	5.51	52.95	35.43	5.62
100	38.32	31.23	5.19	41.05	33.28	5.38	43.79	32.47	5.58	45.40	33.06	5.64	49.26	33.87	5.75	52.00	34.70	5.86
105	37.36	30.37	5.40	40.10	32.42	5.60	42.83	31.68	5.80	44.81	32.54	5.87	48.30	33.13	5.98	51.04	33.98	6.10
110	36.40	29.34	5.61	39.14	31.37	5.82	41.88	30.70	6.03	43.85	31.57	6.10	47.35	32.19	6.21	50.08	33.05	6.34
115	35.45	28.46	5.82	38.18	30.49	6.04	40.92	29.89	6.26	42.90	30.76	6.33	46.39	31.42	6.45	49.13	32.29	6.58
118	34.87	28.25	5.95	37.61	30.30	6.17	40.35	29.74	6.39	42.32	30.63	6.47	45.82	31.31	6.59	48.55	32.21	6.72
122	34.68	28.18	6.12	37.42	30.24	6.34	40.15	29.68	6.58	42.13	30.58	6.65	45.63	31.28	6.78	48.36	32.18	6.91

DB: Dry Bulb Temperature (°F) WB: Wet Bulb Temperature (°F) TC: Total Capacity (kBtu/h)
 SHC: Sensible Capacity (kBtu/h) PI: Power Input (kW) (includes compressor, indoor fan motor and outdoor fan motor)

1. All capacities are net, evaporator fan motor heat is deducted.
2. Cooling range can be extended from 5°F down to -4°F using the Low Ambient Wind Baffle Kit (sold separately).
3. Grey shading indicates reference data. When operating at this temperature, these values can be different if the system is not running consistently.

4. Direct interpolation is permissible. ⚠ Do not extrapolate.

Capacity as rated: 0 ft. above sea level with 24.6 ft. of refrigerant piping. 0 ft. level difference between outdoor and indoor units.

Maximum capacity based on full-load (maximum) compressor operation rather than part-load operation as published in rated capacity tables.



Maximum Cooling Capacity Table for LC429HHV (LCN429HV + LUU420HHV)

Table 33: LCN429HV / LUU420HHV Maximum Cooling Capacities.

Outdoor Air Temp. (°F DB)	Indoor Air Temp. °F DB / °F WB																	
	68 / 57			73 / 61			77 / 64			80 / 67			86 / 72			90 / 75		
	TC	SHC	PI	TC	SHC	PI	TC	SHC	PI	TC	SHC	PI	TC	SHC	PI	TC	SHC	PI
-4	48.17	34.08	3.25	51.17	36.00	3.37	54.16	34.85	3.50	56.32	35.59	3.54	60.14	35.89	3.60	63.13	36.57	3.67
-0.4	48.15	34.27	3.29	51.14	36.21	3.41	54.13	35.06	3.53	56.29	35.80	3.57	60.11	36.10	3.64	63.10	36.78	3.72
5	48.11	34.57	3.34	51.10	36.52	3.47	54.08	35.36	3.59	56.24	36.11	3.63	60.06	36.41	3.70	63.05	37.10	3.78
10	48.07	34.85	3.39	51.06	36.81	3.52	54.04	35.64	3.64	56.20	36.39	3.69	60.01	36.70	3.76	63.00	37.40	3.83
15	48.03	35.12	3.44	51.02	37.10	3.57	54.00	35.93	3.70	56.16	36.68	3.74	59.97	36.99	3.81	62.95	37.69	3.89
20	48.00	35.40	3.49	50.98	37.39	3.62	53.96	36.21	3.75	56.11	36.97	3.79	59.92	37.28	3.87	62.90	37.99	3.94
25	47.96	35.67	3.54	50.94	37.68	3.67	53.92	36.49	3.80	56.07	37.25	3.85	59.88	37.57	3.92	62.85	38.28	4.00
30	47.92	35.95	3.59	50.90	37.97	3.72	53.88	36.77	3.86	56.03	37.54	3.90	59.83	37.86	3.97	62.81	38.57	4.05
35	47.89	36.22	3.64	50.86	38.26	3.77	53.84	37.05	3.91	55.98	37.83	3.96	59.78	38.14	4.03	62.76	38.87	4.11
40	47.85	36.49	3.69	50.82	38.55	3.82	53.79	37.32	3.96	55.94	38.11	4.01	59.74	38.43	4.08	62.71	39.16	4.17
45	47.81	36.76	3.74	50.78	38.84	3.88	53.75	37.60	4.02	55.90	38.39	4.06	59.69	38.72	4.14	62.66	39.45	4.22
50	47.78	37.04	3.79	50.75	39.12	3.93	53.71	37.88	4.07	55.86	38.68	4.12	59.65	39.01	4.19	62.61	39.74	4.28
55	47.74	37.31	3.84	50.71	39.41	3.98	53.67	38.16	4.12	55.81	38.96	4.17	59.60	39.29	4.25	62.57	40.03	4.33
60	47.70	37.58	3.89	50.67	39.70	4.03	53.63	38.44	4.18	55.77	39.24	4.22	59.56	39.58	4.30	62.52	40.33	4.39
65	47.67	37.85	3.94	50.63	39.98	4.08	53.59	38.71	4.23	55.73	39.53	4.28	59.51	39.86	4.36	62.47	40.62	4.45
70	47.63	38.12	3.99	50.59	40.27	4.13	53.55	38.99	4.28	55.68	39.81	4.33	59.46	40.15	4.41	62.42	40.91	4.50
75	46.49	37.49	4.20	49.44	39.66	4.35	52.39	38.44	4.51	54.52	39.28	4.57	58.29	39.66	4.65	61.24	40.44	4.74
80	45.34	36.85	4.42	48.28	39.03	4.58	51.23	37.88	4.74	53.35	38.74	4.80	57.11	39.16	4.89	60.06	39.97	4.99
85	44.20	36.18	4.63	47.14	38.37	4.80	50.08	37.29	4.98	52.20	38.16	5.03	55.95	38.63	5.13	58.88	39.46	5.23
90	43.07	35.49	4.85	46.00	37.70	5.02	48.93	36.69	5.21	51.04	37.58	5.27	54.78	38.09	5.36	57.71	38.95	5.47
95	41.83	35.12	5.06	44.75	37.37	5.25	47.66	36.41	5.44	49.00	36.75	5.50	53.49	37.89	5.60	56.41	38.78	5.72
100	40.82	34.18	5.28	43.73	36.42	5.47	46.64	35.54	5.67	48.37	36.18	5.73	52.47	37.07	5.84	55.39	37.98	5.96
105	39.80	33.24	5.49	42.71	35.48	5.69	45.63	34.67	5.90	47.73	35.61	5.97	51.45	36.26	6.08	54.37	37.18	6.20
110	38.78	32.10	5.71	41.69	34.33	5.91	44.61	33.60	6.13	46.71	34.55	6.20	50.44	35.23	6.32	53.35	36.17	6.44
115	37.76	31.14	5.92	40.67	33.37	6.14	43.59	32.71	6.36	45.69	33.67	6.43	49.42	34.38	6.56	52.33	35.34	6.69
118	37.15	30.92	6.05	40.06	33.16	6.27	42.98	32.54	6.50	45.08	33.52	6.57	48.81	34.27	6.70	51.72	35.25	6.83
122	36.94	30.84	6.22	39.86	33.09	6.45	42.77	32.49	6.68	44.88	33.47	6.76	48.60	34.23	6.89	51.52	35.22	7.03

Performance Data

DB: Dry Bulb Temperature (°F) WB: Wet Bulb Temperature (°F) TC: Total Capacity (kBtu/h)
 SHC: Sensible Capacity (kBtu/h) PI: Power Input (kW) (includes compressor, indoor fan motor and outdoor fan motor)

- All capacities are net, evaporator fan motor heat is deducted.
- Cooling range can be extended from 5°F down to -4°F using the Low Ambient Wind Baffle Kit (sold separately).
- Grey shading indicates reference data. When operating at this temperature, these values can be different if the system is not running consistently.

4. Direct interpolation is permissible. ⚠ Do not extrapolate.
 Capacity as rated: 0 ft. above sea level with 24.6 ft. of refrigerant piping, 0 ft. level difference between outdoor and indoor units.
 Maximum capacity based on full-load (maximum) compressor operation rather than part-load operation as published in rated capacity tables.

PERFORMANCE DATA



Maximum Cooling Capacity

LC489HHV

Maximum Cooling Capacity Table for LC489HHV (LCN489HV + LUU480HHV)

Table 34: LCN489HV / LUU480HHV Maximum Cooling Capacities.

Outdoor Air Temp. (°F DB)	Indoor Air Temp. °F DB / °F WB																	
	68 / 57			73 / 61			77 / 64			80 / 67			86 / 72			90 / 75		
	TC	SHC	PI	TC	SHC	PI	TC	SHC	PI	TC	SHC	PI	TC	SHC	PI	TC	SHC	PI
-4	52.11	37.84	3.44	55.34	39.97	3.57	58.58	38.70	3.70	60.92	39.52	3.74	65.05	39.85	3.81	68.29	40.61	3.89
-0.4	52.08	38.06	3.48	55.31	40.21	3.61	58.55	38.93	3.74	60.88	39.75	3.78	65.01	40.09	3.85	68.25	40.84	3.93
5	52.04	38.39	3.54	55.27	40.56	3.67	58.50	39.27	3.80	60.83	40.10	3.84	64.96	40.43	3.92	68.19	41.20	4.00
10	52.00	38.70	3.59	55.22	40.88	3.72	58.45	39.58	3.86	60.79	40.42	3.90	64.91	40.76	3.97	68.14	41.53	4.05
15	51.96	39.00	3.64	55.18	41.20	3.78	58.41	39.89	3.91	60.74	40.73	3.96	64.86	41.08	4.03	68.09	41.86	4.11
20	51.92	39.31	3.69	55.14	41.52	3.83	58.36	40.21	3.97	60.69	41.05	4.01	64.81	41.40	4.09	68.04	42.18	4.17
25	51.88	39.61	3.75	55.10	41.85	3.88	58.32	40.52	4.03	60.65	41.37	4.07	64.76	41.72	4.15	67.99	42.51	4.23
30	51.84	39.92	3.80	55.06	42.17	3.94	58.28	40.83	4.08	60.60	41.69	4.13	64.71	42.04	4.21	67.93	42.84	4.29
35	51.80	40.22	3.85	55.01	42.49	3.99	58.23	41.14	4.14	60.55	42.00	4.19	64.66	42.36	4.26	67.88	43.16	4.35
40	51.76	40.52	3.90	54.97	42.81	4.05	58.19	41.45	4.19	60.51	42.32	4.24	64.62	42.68	4.32	67.83	43.49	4.41
45	51.72	40.83	3.96	54.93	43.13	4.10	58.14	41.76	4.25	60.46	42.64	4.30	64.57	43.00	4.38	67.78	43.81	4.47
50	51.68	41.13	4.01	54.89	43.45	4.15	58.10	42.07	4.31	60.42	42.95	4.36	64.52	43.31	4.44	67.73	44.13	4.53
55	51.64	41.43	4.06	54.85	43.76	4.21	58.05	42.37	4.36	60.37	43.27	4.41	64.47	43.63	4.50	67.67	44.46	4.59
60	51.60	41.73	4.11	54.80	44.08	4.26	58.01	42.68	4.42	60.32	43.58	4.47	64.42	43.95	4.55	67.62	44.78	4.65
65	51.56	42.03	4.17	54.76	44.40	4.32	57.96	42.99	4.48	60.28	43.89	4.53	64.37	44.26	4.61	67.57	45.10	4.70
70	51.52	42.33	4.22	54.72	44.71	4.37	57.92	43.30	4.53	60.23	44.21	4.58	64.32	44.58	4.67	67.52	45.42	4.76
75	50.28	41.63	4.45	53.47	44.04	4.61	56.66	42.69	4.78	58.97	43.62	4.83	63.05	44.04	4.92	66.24	44.91	5.02
80	49.04	40.92	4.67	52.22	43.34	4.84	55.41	42.06	5.02	57.71	43.02	5.08	61.78	43.49	5.17	64.96	44.38	5.28
85	47.81	40.17	4.90	50.99	42.61	5.08	54.16	41.41	5.26	56.46	42.38	5.33	60.52	42.90	5.43	63.69	43.82	5.53
90	46.58	39.42	5.13	49.75	41.87	5.32	52.92	40.74	5.51	55.21	41.73	5.57	59.26	42.30	5.68	62.42	43.25	5.79
95	45.25	39.00	5.36	48.40	41.49	5.55	51.55	40.43	5.75	53.00	40.81	5.82	57.86	42.07	5.93	61.01	43.06	6.05
100	44.15	37.95	5.58	47.30	40.44	5.79	50.45	39.46	6.00	52.31	40.18	6.07	56.76	41.16	6.18	59.91	42.17	6.31
105	43.05	36.91	5.81	46.20	39.40	6.02	49.35	38.50	6.24	51.63	39.55	6.31	55.65	40.26	6.43	58.81	41.29	6.56
110	41.94	35.65	6.04	45.10	38.12	6.26	48.25	37.31	6.49	50.52	38.36	6.56	54.55	39.12	6.68	57.71	40.16	6.82
115	40.84	34.58	6.27	43.99	37.05	6.49	47.15	36.32	6.73	49.42	37.39	6.81	53.45	38.18	6.94	56.60	39.25	7.08
118	40.18	34.33	6.40	43.33	36.83	6.64	46.49	36.14	6.88	48.76	37.22	6.96	52.79	38.05	7.09	55.94	39.14	7.23
122	39.96	34.25	6.58	43.11	36.75	6.82	46.26	36.08	7.07	48.54	37.17	7.16	52.57	38.01	7.29	55.72	39.11	7.44

DB: Dry Bulb Temperature (°F) WB: Wet Bulb Temperature (°F) TC: Total Capacity (kBtu/h)
 SHC: Sensible Capacity (kBtu/h) PI: Power Input (kW) (includes compressor, indoor fan motor and outdoor fan motor)

- All capacities are net, evaporator fan motor heat is deducted.
- Cooling range can be extended from 5°F down to -4°F using the Low Ambient Wind Baffle Kit (sold separately).
- Grey shading indicates reference data. When operating at this temperature, these values can be different if the system is not running consistently.

4. Direct interpolation is permissible. ⚠ Do not extrapolate.

Capacity as rated: 0 ft. above sea level with 24.6 ft. of refrigerant piping, 0 ft. level difference between outdoor and indoor units.

Maximum capacity based on full-load (maximum) compressor operation rather than part-load operation as published in rated capacity tables.



Heating Capacity Table for LC188HHV4 (LCN188HV4 + LUU180HHV)

Table 36: LCN188HV4 / LUU180HHV Heating Capacities.

Outdoor Air Temp.		Indoor Air Temp. °F DB											
°F DB	°F WB	61		64		68		70		72		75	
		TC	PI	TC	PI	TC	PI	TC	PI	TC	PI	TC	PI
-13	-13.4	7.63	1.15	6.85	1.18	6.95	1.22	6.90	1.24	6.86	1.25	6.52	1.29
-4	-4.4	10.24	1.23	9.56	1.27	9.46	1.30	9.34	1.33	9.24	1.34	8.84	1.38
0	-0.4	11.45	1.27	10.80	1.30	10.61	1.34	10.46	1.37	10.33	1.38	9.90	1.42
5	4.5	12.88	1.31	12.29	1.35	11.99	1.39	11.79	1.42	11.64	1.43	11.17	1.47
10	9	13.84	1.35	13.28	1.39	12.91	1.44	12.69	1.46	12.51	1.48	12.02	1.52
17	15	14.89	1.41	14.38	1.45	13.92	1.50	13.67	1.52	13.47	1.54	12.95	1.58
20	19	15.53	1.44	15.04	1.49	14.54	1.53	14.27	1.56	14.05	1.58	13.52	1.63
25	23	16.61	1.48	16.11	1.53	15.55	1.57	15.26	1.60	15.02	1.62	14.46	1.67
30	28	17.69	1.52	17.14	1.57	16.56	1.62	16.25	1.65	16.01	1.67	15.42	1.72
35	32	18.78	1.56	18.18	1.61	17.56	1.66	17.24	1.69	16.99	1.71	16.38	1.76
40	36	19.73	1.60	19.18	1.65	18.57	1.70	18.25	1.73	17.99	1.75	17.34	1.81
45	41	20.93	1.64	20.43	1.70	19.83	1.75	19.50	1.78	19.24	1.80	18.54	1.86
47	43	21.41	1.66	20.93	1.71	20.33	1.77	20.00	1.80	19.73	1.82	19.02	1.88
50	46	21.47	1.65	21.04	1.70	20.52	1.75	20.22	1.77	19.98	1.80	19.31	1.84
55	51	21.58	1.63	21.22	1.67	20.83	1.71	20.59	1.73	20.40	1.75	19.79	1.78
60	56	21.68	1.61	21.40	1.65	21.14	1.68	20.95	1.69	20.81	1.70	20.28	1.72
63	59	21.74	1.60	21.51	1.63	21.32	1.65	21.18	1.66	21.06	1.67	20.57	1.69
68	64	21.81	1.59	21.62	1.61	21.51	1.63	21.40	1.64	21.31	1.64	20.86	1.65

Heating Capacity Table for LC249HHV (LCN249HV + LUU240HHV)

Table 35: LCN249HV / LUU240HHV Heating Capacities.

Outdoor Air Temp.		Indoor Air Temp. °F DB											
°F DB	°F WB	61		64		68		70		72		75	
		TC	PI	TC	PI	TC	PI	TC	PI	TC	PI	TC	PI
-13	-13.4	7.00	1.43	6.09	1.48	6.31	1.52	6.30	1.55	6.28	1.56	5.95	1.61
-4	-4.4	11.30	1.54	10.49	1.58	10.42	1.63	10.29	1.66	10.19	1.68	9.74	1.73
0	-0.4	13.29	1.58	12.51	1.63	12.31	1.68	12.14	1.71	12.00	1.73	11.49	1.78
5	4.5	15.65	1.64	14.92	1.69	14.56	1.74	14.33	1.77	14.14	1.79	13.57	1.84
10	9	17.23	1.69	16.53	1.74	16.07	1.80	15.80	1.83	15.57	1.85	14.96	1.90
17	15	18.97	1.76	18.31	1.81	17.73	1.87	17.41	1.90	17.15	1.92	16.49	1.98
20	19	20.02	1.80	19.38	1.86	18.74	1.92	18.39	1.95	18.11	1.98	17.42	2.03
25	23	21.79	1.85	21.14	1.91	20.41	1.97	20.02	2.00	19.71	2.03	18.97	2.09
30	28	23.57	1.90	22.84	1.97	22.05	2.03	21.65	2.06	21.33	2.09	20.54	2.15
35	32	25.35	1.95	24.54	2.01	23.71	2.08	23.28	2.11	22.94	2.14	22.11	2.20
40	36	26.64	2.00	25.89	2.06	25.07	2.13	24.63	2.16	24.29	2.19	23.41	2.26
45	41	28.26	2.05	27.58	2.12	26.77	2.19	26.32	2.23	25.97	2.26	25.02	2.32
47	43	28.90	2.07	28.26	2.14	27.45	2.21	27.00	2.25	26.64	2.28	25.67	2.35
50	46	28.99	2.06	28.40	2.12	27.70	2.18	27.30	2.22	26.98	2.24	26.07	2.30
55	51	29.13	2.04	28.65	2.09	28.12	2.14	27.79	2.16	27.54	2.18	26.72	2.23
60	56	29.27	2.02	28.89	2.06	28.53	2.09	28.29	2.11	28.09	2.12	27.38	2.16
63	59	29.35	2.01	29.03	2.04	28.78	2.07	28.59	2.08	28.43	2.09	27.77	2.11
68	64	29.44	1.99	29.18	2.02	29.04	2.04	28.89	2.05	28.77	2.05	28.17	2.07

DB: Dry Bulb Temperature (°F) WB: Wet Bulb Temperature (°F) TC: Total Capacity (kBtu/h)

PI: Power Input (kW) (includes compressor, indoor fan motor and outdoor fan motor)

1. All capacities are net, evaporator fan motor heat is deducted.
2. Direct interpolation is permissible. Ⓞ Do not extrapolate.

Capacity as rated: 0 ft. above sea level with 24.6 ft. of refrigerant piping. 0 ft. level difference between outdoor and indoor units.

Heating capacity rating obtained with air entering the indoor unit at 70°F dry bulb (DB) and 60°F wet bulb (WB), and outdoor ambient conditions of 47°F dry bulb (DB) and 43°F wet bulb (WB).

PERFORMANCE DATA



Heating Capacity

LC369HHV, LC429HHV

Heating Capacity Table for LC369HHV (LCN369HV + LUU360HHV)

Table 37: LCN369HV / LUU360HHV Heating Capacities.

Outdoor Air Temp.		Indoor Air Temp. °F DB											
°F DB	°F WB	61		64		68		70		72		75	
		TC	PI	TC	PI	TC	PI	TC	PI	TC	PI	TC	PI
-13	-13.4	9.45	1.94	8.15	2.00	8.49	2.06	8.48	2.09	8.47	2.12	8.01	2.18
-4	-4.4	16.04	2.10	14.86	2.17	14.77	2.23	14.60	2.27	14.46	2.30	13.82	2.36
0	-0.4	19.08	2.17	17.96	2.24	17.67	2.31	17.42	2.35	17.22	2.38	16.50	2.45
5	4.5	22.70	2.26	21.64	2.33	21.12	2.40	20.78	2.44	20.51	2.48	19.68	2.55
10	9	25.12	2.34	24.10	2.42	23.43	2.49	23.03	2.53	22.71	2.57	21.81	2.64
17	15	27.78	2.45	26.82	2.53	25.97	2.61	25.50	2.65	25.12	2.68	24.16	2.76
20	19	29.40	2.52	28.46	2.60	27.51	2.68	27.00	2.73	26.59	2.76	25.58	2.85
25	23	32.10	2.59	31.15	2.68	30.06	2.76	29.50	2.81	29.04	2.84	27.95	2.93
30	28	34.83	2.68	33.75	2.77	32.59	2.86	31.99	2.91	31.51	2.94	30.36	3.03
35	32	37.55	2.75	36.36	2.84	35.12	2.93	34.49	2.98	33.98	3.02	32.76	3.11
40	36	39.47	2.83	38.36	2.92	37.14	3.01	36.49	3.06	35.98	3.10	34.68	3.20
45	41	41.86	2.91	40.86	3.01	39.66	3.11	39.00	3.16	38.47	3.20	37.07	3.30
47	43	42.82	2.95	41.86	3.05	40.66	3.15	40.00	3.20	39.47	3.24	38.03	3.34
50	46	42.94	2.93	42.08	3.02	41.04	3.11	40.44	3.15	39.97	3.19	38.62	3.28
55	51	43.15	2.90	42.44	2.97	41.65	3.04	41.18	3.08	40.79	3.11	39.59	3.17
60	56	43.36	2.87	42.80	2.93	42.27	2.98	41.91	3.00	41.62	3.02	40.56	3.07
63	59	43.49	2.85	43.01	2.90	42.64	2.94	42.35	2.96	42.12	2.97	41.14	3.00
68	64	43.61	2.83	43.23	2.87	43.02	2.90	42.80	2.91	42.62	2.92	41.73	2.94

Heating Capacity Table for LC429HHV (LCN429HV + LUU420HHV)

Table 38: LCN429HV / LUU420HHV Heating Capacities.

Outdoor Air Temp.		Indoor Air Temp. °F DB											
°F DB	°F WB	61		64		68		70		72		75	
		TC	PI	TC	PI	TC	PI	TC	PI	TC	PI	TC	PI
-13	-13.4	7.17	1.96	5.79	2.01	6.30	2.07	6.36	2.11	6.40	2.13	5.99	2.19
-4	-4.4	16.06	2.14	14.78	2.21	14.76	2.28	14.60	2.31	14.47	2.34	13.81	2.41
0	-0.4	20.17	2.23	18.93	2.30	18.66	2.37	18.40	2.41	18.20	2.44	17.42	2.51
5	4.5	25.04	2.33	23.86	2.40	23.30	2.48	22.92	2.52	22.62	2.55	21.71	2.62
10	9	28.31	2.43	27.16	2.50	26.40	2.58	25.95	2.62	25.59	2.66	24.58	2.73
17	15	31.90	2.55	30.79	2.63	29.82	2.71	29.28	2.76	28.85	2.80	27.74	2.88
20	19	34.08	2.64	32.99	2.72	31.89	2.81	31.30	2.85	30.82	2.89	29.65	2.97
25	23	37.72	2.72	36.60	2.81	35.33	2.90	34.66	2.94	34.13	2.98	32.84	3.07
30	28	41.39	2.82	40.11	2.92	38.74	3.01	38.02	3.06	37.46	3.10	36.08	3.19
35	32	45.07	2.91	43.63	3.00	42.14	3.10	41.39	3.15	40.78	3.19	39.31	3.29
40	36	47.36	2.99	46.03	3.09	44.56	3.19	43.79	3.24	43.17	3.29	41.61	3.39
45	41	50.23	3.10	49.03	3.20	47.59	3.30	46.80	3.36	46.17	3.40	44.49	3.51
47	43	51.38	3.14	50.23	3.24	48.80	3.35	48.00	3.41	47.36	3.45	45.64	3.55
50	46	51.53	3.12	50.49	3.21	49.24	3.31	48.53	3.36	47.96	3.40	46.34	3.49
55	51	51.78	3.09	50.92	3.16	49.98	3.24	49.41	3.28	48.95	3.30	47.50	3.38
60	56	52.03	3.05	51.36	3.11	50.73	3.17	50.29	3.19	49.94	3.21	48.67	3.26
63	59	52.19	3.03	51.62	3.08	51.17	3.13	50.82	3.15	50.54	3.16	49.37	3.20
68	64	52.34	3.01	51.88	3.05	51.62	3.09	51.36	3.10	51.14	3.10	50.07	3.13

DB: Dry Bulb Temperature (°F) WB: Wet Bulb Temperature (°F) TC: Total Capacity (kBtu/h)
 PI: Power Input (kW) (includes compressor, indoor fan motor and outdoor fan motor)

1. All capacities are net, evaporator fan motor heat is deducted.
2. Direct interpolation is permissible. ⊙ Do not extrapolate.

Capacity as rated: 0 ft. above sea level with 24.6 ft. of refrigerant piping. 0 ft. level difference between outdoor and indoor units.

Heating capacity rating obtained with air entering the indoor unit at 70°F dry bulb (DB) and 60°F wet bulb (WB), and outdoor ambient conditions of 47°F dry bulb (DB) and 43°F wet bulb (WB).



Heating Capacity Table for LC489HHV (LCN489HV + LUU480HHV)

Table 39: LCN489HV / LUU480HHV Heating Capacities.

Outdoor Air Temp.		Indoor Air Temp. °F DB											
°F DB	°F WB	61		64		68		70		72		75	
		TC	PI	TC	PI	TC	PI	TC	PI	TC	PI	TC	PI
-13	-13.4	11.12	2.36	9.47	2.43	9.94	2.50	9.95	2.54	9.96	2.57	9.40	2.64
-4	-4.4	19.96	2.55	18.46	2.63	18.37	2.71	18.16	2.75	17.99	2.78	17.18	2.86
0	-0.4	24.04	2.63	22.61	2.72	22.26	2.80	21.95	2.84	21.70	2.88	20.78	2.96
5	4.5	28.89	2.74	27.54	2.82	26.88	2.91	26.45	2.96	26.10	2.99	25.05	3.08
10	9	32.14	2.83	30.84	2.92	29.98	3.01	29.46	3.06	29.05	3.10	27.91	3.19
17	15	35.71	2.96	34.47	3.05	33.38	3.15	32.78	3.20	32.30	3.24	31.05	3.34
20	19	37.88	3.04	36.67	3.14	35.45	3.24	34.79	3.29	34.26	3.34	32.96	3.43
25	23	41.50	3.13	40.27	3.23	38.87	3.33	38.14	3.39	37.55	3.43	36.14	3.53
30	28	45.16	3.23	43.77	3.34	42.26	3.44	41.49	3.50	40.87	3.55	39.36	3.65
35	32	48.82	3.32	47.27	3.43	45.66	3.53	44.84	3.59	44.18	3.64	42.58	3.75
40	36	51.31	3.40	49.87	3.51	48.28	3.63	47.44	3.69	46.77	3.74	45.08	3.85
45	41	54.42	3.51	53.12	3.62	51.55	3.74	50.70	3.80	50.01	3.86	48.20	3.97
47	43	55.66	3.55	54.42	3.67	52.86	3.78	52.00	3.85	51.31	3.90	49.44	4.02
50	46	55.83	3.53	54.70	3.63	53.35	3.74	52.57	3.79	51.95	3.84	50.20	3.94
55	51	56.10	3.49	55.17	3.58	54.15	3.66	53.53	3.70	53.03	3.74	51.46	3.82
60	56	56.37	3.45	55.64	3.52	54.95	3.58	54.48	3.61	54.11	3.63	52.72	3.69
63	59	56.53	3.43	55.92	3.49	55.44	3.54	55.06	3.56	54.75	3.57	53.48	3.61
68	64	56.70	3.41	56.20	3.45	55.92	3.49	55.63	3.50	55.41	3.51	54.25	3.54

DB: Dry Bulb Temperature (°F) WB: Wet Bulb Temperature (°F) TC: Total Capacity (kBtu/h)
PI: Power Input (kW) (includes compressor, indoor fan motor and outdoor fan motor)

1. All capacities are net, evaporator fan motor heat is deducted.
2. Direct interpolation is permissible. Ⓞ Do not extrapolate.

Capacity as rated: 0 ft. above sea level with 24.6 ft. of refrigerant piping. 0 ft. level difference between outdoor and indoor units.

Heating capacity rating obtained with air entering the indoor unit at 70°F dry bulb (DB) and 60°F wet bulb (WB), and outdoor ambient conditions of 47°F dry bulb (DB) and 43°F wet bulb (WB).

PERFORMANCE DATA



Maximum Heating Capacity

LC188HHV4, LC249HHV

Maximum Heating Capacity Table for LC188HHV4 (LCN188HV4 + LUU180HHV)

Table 40: LCN188HV4 / LUU180HHV Maximum Heating Capacities.

Outdoor Air Temp.		Indoor Air Temp. °F DB											
°F DB	°F WB	61		64		68		70		72		75	
		TC	PI	TC	PI	TC	PI	TC	PI	TC	PI	TC	PI
-13	-13.4	17.12	3.33	16.74	3.44	16.26	3.55	15.99	3.61	15.78	3.66	15.21	3.77
-4	-4.4	19.19	3.17	18.76	3.28	18.22	3.38	17.92	3.44	17.69	3.49	17.04	3.59
0	-0.4	20.17	3.13	19.72	3.23	19.16	3.34	18.85	3.40	18.60	3.44	17.92	3.55
5	4.5	21.41	3.08	20.93	3.18	20.33	3.28	20.00	3.34	19.73	3.39	19.02	3.49
10	9	22.56	3.11	22.05	3.21	21.42	3.31	21.07	3.37	20.79	3.41	20.04	3.52
17	15	24.08	3.13	23.55	3.23	22.87	3.33	22.50	3.39	22.20	3.44	21.39	3.54
20	19	24.27	3.02	23.73	3.12	23.05	3.22	22.67	3.28	22.37	3.32	21.56	3.42
25	23	24.45	2.92	23.91	3.01	23.22	3.11	22.84	3.16	22.54	3.21	21.72	3.30
30	28	24.68	2.79	24.13	2.88	23.44	2.97	23.06	3.02	22.75	3.06	21.92	3.16
35	32	24.86	2.68	24.31	2.77	23.61	2.86	23.23	2.91	22.92	2.95	22.09	3.04
40	36	25.05	2.58	24.49	2.66	23.79	2.75	23.40	2.80	23.09	2.84	22.25	2.92
45	41	25.28	2.45	24.71	2.53	24.01	2.61	23.61	2.66	23.30	2.69	22.45	2.77
47	43	25.37	2.40	24.80	2.48	24.09	2.56	23.70	2.60	23.39	2.64	22.53	2.71
50	46	25.44	2.38	24.93	2.45	24.31	2.52	23.96	2.56	23.68	2.59	22.88	2.66
55	51	25.57	2.36	25.14	2.42	24.68	2.47	24.40	2.50	24.17	2.52	23.45	2.58
60	56	25.69	2.33	25.36	2.38	25.05	2.42	24.83	2.44	24.66	2.45	24.03	2.49
63	59	25.77	2.32	25.49	2.35	25.27	2.39	25.09	2.40	24.95	2.41	24.37	2.44
68	64	25.84	2.30	25.61	2.33	25.49	2.36	25.36	2.36	25.25	2.37	24.72	2.39

Maximum Heating Capacity Table for LC249HHV (LCN249HV + LUU240HHV)

Table 41: LCN249HV / LUU240HHV Maximum Heating Capacities.

Outdoor Air Temp.		Indoor Air Temp. °F DB											
°F DB	°F WB	61		64		68		70		72		75	
		TC	PI	TC	PI	TC	PI	TC	PI	TC	PI	TC	PI
-13	-13.4	23.13	4.36	22.61	4.50	21.97	4.64	21.61	4.73	21.32	4.79	20.55	4.93
-4	-4.4	26.13	4.27	25.54	4.42	24.81	4.56	24.41	4.64	24.08	4.70	23.21	4.84
0	-0.4	27.36	4.22	26.75	4.36	25.98	4.50	25.56	4.58	25.22	4.64	24.30	4.78
5	4.5	28.90	4.15	28.26	4.29	27.45	4.42	27.00	4.50	26.64	4.56	25.67	4.70
10	9	29.68	4.04	29.02	4.18	28.19	4.31	27.73	4.38	27.36	4.44	26.37	4.58
17	15	30.72	3.97	30.03	4.10	29.18	4.23	28.70	4.30	28.32	4.36	27.29	4.49
20	19	31.38	3.90	30.68	4.03	29.80	4.16	29.31	4.23	28.92	4.29	27.87	4.41
25	23	32.04	3.83	31.32	3.96	30.43	4.09	29.93	4.16	29.53	4.21	28.46	4.34
30	28	32.86	3.75	32.12	3.87	31.21	4.00	30.70	4.07	30.29	4.12	29.19	4.25
35	32	33.52	3.69	32.77	3.81	31.83	3.93	31.31	4.00	30.89	4.05	29.77	4.17
40	36	34.17	3.62	33.41	3.74	32.46	3.86	31.93	3.93	31.50	3.98	30.36	4.10
45	41	35.00	3.54	34.21	3.65	33.24	3.77	32.69	3.84	32.26	3.89	31.09	4.00
47	43	35.32	3.50	34.53	3.62	33.55	3.74	33.00	3.80	32.56	3.85	31.38	3.97
50	46	35.43	3.48	34.71	3.59	33.85	3.69	33.36	3.75	32.97	3.79	31.86	3.89
55	51	35.60	3.45	35.01	3.53	34.36	3.61	33.97	3.66	33.65	3.69	32.66	3.77
60	56	35.77	3.41	35.31	3.47	34.87	3.54	34.58	3.56	34.34	3.59	33.46	3.64
63	59	35.88	3.39	35.49	3.44	35.18	3.49	34.94	3.51	34.75	3.52	33.94	3.57
68	64	35.98	3.36	35.67	3.41	35.49	3.45	35.31	3.46	35.16	3.46	34.43	3.49

DB: Dry Bulb Temperature (°F) WB: Wet Bulb Temperature (°F) TC: Total Capacity (kBtu/h)
 PI: Power Input (kW) (includes compressor, indoor fan motor and outdoor fan motor)

1. All capacities are net, evaporator fan motor heat is deducted.
2. Direct interpolation is permissible. ⚠ Do not extrapolate.
3. Grey shading indicates reference data. When operating at this temperature, these values can be different if the system is not running consistently.

Capacity as rated: 0 ft. above sea level with 24.6 ft. of refrigerant piping. 0 ft. level difference between outdoor and indoor units.

Maximum capacity based on full-load (maximum) compressor operation rather than part-load operation as published in rated capacity tables.



Maximum Heating Capacity Table for LC369HHV (LCN369HV + LUU360HHV)

Table 42: LCN369HV / LUU360HHV Maximum Heating Capacities.

Outdoor Air Temp.		Indoor Air Temp. °F DB											
°F DB	°F WB	61		64		68		70		72		75	
		TC	PI	TC	PI	TC	PI	TC	PI	TC	PI	TC	PI
-13	-13.4	32.11	5.22	31.40	5.39	30.50	5.57	30.00	5.66	29.60	5.74	28.53	5.91
-4	-4.4	38.50	5.83	37.64	6.03	36.56	6.22	35.97	6.33	35.49	6.41	34.20	6.61
0	-0.4	40.42	5.97	39.51	6.17	38.39	6.37	37.76	6.48	37.26	6.56	35.90	6.76
5	4.5	42.82	6.14	41.86	6.34	40.66	6.55	40.00	6.66	39.47	6.75	38.03	6.95
10	9	43.60	5.84	42.62	6.03	41.41	6.23	40.73	6.33	40.19	6.42	38.73	6.61
17	15	44.64	5.62	43.64	5.81	42.39	6.00	41.70	6.10	41.15	6.18	39.65	6.37
20	19	45.29	5.44	44.28	5.62	43.02	5.80	42.31	5.90	41.75	5.98	40.23	6.16
25	23	45.95	5.26	44.93	5.43	43.64	5.60	42.93	5.70	42.36	5.78	40.82	5.95
30	28	46.77	5.03	45.73	5.19	44.42	5.36	43.70	5.45	43.12	5.52	41.55	5.69
35	32	47.43	4.84	46.37	5.00	45.05	5.16	44.31	5.25	43.72	5.32	42.13	5.48
40	36	48.09	4.66	47.01	4.81	45.67	4.96	44.93	5.05	44.33	5.12	42.72	5.27
45	41	48.91	4.43	47.82	4.57	46.45	4.72	45.69	4.80	45.09	4.87	43.45	5.01
47	43	49.24	4.33	48.14	4.48	46.76	4.62	46.00	4.70	45.39	4.76	43.74	4.91
50	46	49.38	4.31	48.39	4.44	47.19	4.56	46.51	4.63	45.96	4.69	44.41	4.81
55	51	49.63	4.26	48.80	4.37	47.90	4.47	47.35	4.52	46.91	4.56	45.52	4.66
60	56	49.87	4.22	49.22	4.30	48.61	4.38	48.20	4.41	47.86	4.43	46.64	4.50
63	59	50.01	4.19	49.47	4.26	49.04	4.32	48.70	4.34	48.43	4.36	47.31	4.41
68	64	50.16	4.16	49.72	4.21	49.47	4.26	49.22	4.28	49.01	4.28	47.99	4.32

Maximum Heating Capacity Table for LC429HHV (LCN429HV + LUU420HHV)

Table 43: LCN429HV / LUU420HHV Maximum Heating Capacities.

Outdoor Air Temp.		Indoor Air Temp. °F DB											
°F DB	°F WB	61		64		68		70		72		75	
		TC	PI	TC	PI	TC	PI	TC	PI	TC	PI	TC	PI
-13	-13.4	38.52	5.73	37.66	5.92	36.58	6.10	35.99	6.21	35.51	6.29	34.22	6.48
-4	-4.4	45.99	6.24	44.96	6.44	43.68	6.65	42.97	6.76	42.39	6.85	40.85	7.06
0	-0.4	48.39	6.29	47.31	6.50	45.95	6.71	45.20	6.82	44.60	6.92	42.98	7.12
5	4.5	51.38	6.36	50.23	6.57	48.80	6.78	48.00	6.90	47.36	6.99	45.64	7.20
10	9	52.62	6.19	51.44	6.40	49.97	6.60	49.16	6.71	48.50	6.81	46.74	7.01
17	15	54.27	6.07	53.06	6.27	51.54	6.47	50.70	6.58	50.03	6.67	48.21	6.87
20	19	55.33	5.96	54.09	6.16	52.54	6.36	51.69	6.47	51.00	6.56	49.14	6.75
25	23	56.38	5.86	55.12	6.06	53.55	6.25	52.67	6.36	51.97	6.44	50.08	6.64
30	28	57.70	5.73	56.41	5.92	54.80	6.11	53.90	6.22	53.19	6.30	51.25	6.49
35	32	58.76	5.63	57.44	5.82	55.80	6.00	54.89	6.11	54.16	6.19	52.19	6.38
40	36	59.81	5.53	58.47	5.71	56.80	5.89	55.88	6.00	55.13	6.08	53.13	6.26
45	41	61.13	5.40	59.76	5.58	58.06	5.76	57.11	5.86	56.35	5.94	54.30	6.11
47	43	61.66	5.35	60.28	5.52	58.56	5.70	57.60	5.80	56.83	5.88	54.77	6.06
50	46	61.84	5.31	60.59	5.47	59.09	5.63	58.23	5.72	57.55	5.78	55.61	5.94
55	51	62.14	5.26	61.11	5.39	59.98	5.52	59.29	5.58	58.74	5.63	57.00	5.75
60	56	62.44	5.20	61.63	5.30	60.87	5.40	60.35	5.44	59.93	5.47	58.40	5.56
63	59	62.62	5.17	61.94	5.25	61.41	5.33	60.98	5.36	60.65	5.38	59.24	5.44
68	64	62.80	5.13	62.25	5.20	61.94	5.26	61.63	5.28	61.37	5.29	60.09	5.33

DB: Dry Bulb Temperature (°F) WB: Wet Bulb Temperature (°F) TC: Total Capacity (kBtu/h)
 PI: Power Input (kW) (includes compressor, indoor fan motor and outdoor fan motor)
 1. All capacities are net, evaporator fan motor heat is deducted.
 2. Direct interpolation is permissible. Ⓞ Do not extrapolate.
 3. Grey shading indicates reference data. When operating at this temperature, these values can be different if the system is not running consistently.

Capacity as rated: 0 ft. above sea level with 24.6 ft. of refrigerant piping, 0 ft. level difference between outdoor and indoor units.
 Maximum capacity based on full-load (maximum) compressor operation rather than part-load operation as published in rated capacity tables.

PERFORMANCE DATA



Maximum Heating Capacity

LC489HHV

Maximum Heating Capacity Table for LC489HHV (LCN489HV + LUU480HHV)

Table 44: LCN489HV / LUU480HHV Maximum Heating Capacities.

Outdoor Air Temp.		Indoor Air Temp. °F DB											
°F DB	°F WB	61		64		68		70		72		75	
		TC	PI	TC	PI	TC	PI	TC	PI	TC	PI	TC	PI
-13	-13.4	38.51	5.68	37.65	5.87	36.57	6.06	35.98	6.17	35.50	6.25	34.21	6.44
-4	-4.4	46.82	6.19	45.77	6.39	44.46	6.60	43.74	6.71	43.15	6.80	41.59	7.01
0	-0.4	50.75	6.25	49.61	6.45	48.20	6.66	47.41	6.77	46.78	6.87	45.08	7.07
5	4.5	55.66	6.32	54.42	6.53	52.86	6.73	52.00	6.85	51.31	6.94	49.44	7.15
10	9	56.81	6.21	55.54	6.42	53.95	6.63	53.07	6.74	52.37	6.83	50.46	7.04
17	15	58.34	6.14	57.03	6.34	55.41	6.55	54.50	6.66	53.78	6.75	51.82	6.95
20	19	59.33	6.08	58.01	6.28	56.35	6.48	55.43	6.59	54.69	6.68	52.70	6.88
25	23	60.33	6.02	58.98	6.22	57.29	6.42	56.36	6.53	55.61	6.62	53.59	6.82
30	28	61.57	5.94	60.19	6.14	58.47	6.34	57.52	6.45	56.75	6.53	54.69	6.73
35	32	62.56	5.88	61.16	6.08	59.42	6.27	58.45	6.38	57.67	6.47	55.57	6.66
40	36	63.56	5.82	62.14	6.02	60.36	6.21	59.38	6.32	58.59	6.40	56.46	6.59
45	41	64.80	5.75	63.35	5.94	61.54	6.13	60.54	6.23	59.73	6.32	57.56	6.51
47	43	65.30	5.72	63.84	5.91	62.01	6.10	61.00	6.20	60.19	6.28	58.00	6.47
50	46	65.49	5.68	64.17	5.85	62.58	6.02	61.67	6.11	60.95	6.18	58.89	6.35
55	51	65.81	5.62	64.72	5.76	63.52	5.90	62.79	5.96	62.21	6.02	60.37	6.15
60	56	66.13	5.56	65.27	5.67	64.46	5.77	63.91	5.82	63.47	5.85	61.85	5.94
63	59	66.32	5.52	65.60	5.61	65.03	5.70	64.58	5.73	64.23	5.75	62.74	5.82
68	64	66.51	5.49	65.93	5.56	65.60	5.62	65.26	5.64	64.99	5.65	63.64	5.70

DB: Dry Bulb Temperature (°F) WB: Wet Bulb Temperature (°F) TC: Total Capacity (kBtu/h)

PI: Power Input (kW) (includes compressor, indoor fan motor and outdoor fan motor)

1. All capacities are net, evaporator fan motor heat is deducted.
2. Direct interpolation is permissible. ⊙ Do not extrapolate.
3. Grey shading indicates reference data. When operating at this temperature, these values can be different if the system is not running consistently.

Capacity as rated: 0 ft. above sea level with 24.6 ft. of refrigerant piping. 0 ft. level difference between outdoor and indoor units.

Maximum capacity based on full-load (maximum) compressor operation rather than part-load operation as published in rated capacity tables.



Cooling / Heating Correction Factors

For Four-Way Ceiling Cassette systems, calculate the equivalent length of the liquid line from the outdoor unit to the indoor unit. Also, determine the elevation difference of the indoor unit above or below the outdoor unit. Find corresponding cooling or heating capacity correction factors as shown below. Multiply the correction factors by the cooling or heating capacity obtained from the capacity table using design conditions. The resultant is the NET cooling or heating capacity.

Refrigerant Line Length Derates

For air-cooled systems, a capacity correction factor will have to be applied to account for the length of the system's refrigerant pipe. Rate of change in capacity due to increased piping lengths is shown below.

Table 45: 18,000 to 48,000 Btu/h Capacity Cassette System Cooling and Heating Capacity Coefficient Factors.

Piping Length (ft.)		16.4	24.6	32.8	49.2	65.6	82.0	98.4	114.8	131.2	147.6	164	180.4	196.9	213.3	229.7	246
<i>Cooling Capacity Coefficient Factor.</i>																	
Rate of Capacity Change (%)	LC188HHV4 (18,000 Btu/h)	100	100	100	100	100	99.4	98.8	98.2	97.5	96.9	96.3	-	-	-	-	-
	LC249HHV (24,000 Btu/h)	100	100	100	100	100	99.4	98.8	98.2	97.5	96.9	96.3	-	-	-	-	-
	LC369HHV (36,000 Btu/h)	100	100	100	100	100	99.3	98.5	97.8	97.0	96.3	95.5	94.8	94.0	93.3	92.5	91.8
	LC429HHV (42,000 Btu/h)	100	100	98.8	97.5	96.3	95.1	93.9	92.7	91.5	90.3	89.1	87.9	86.7	85.5	84.3	83.1
	LC489HHV (48,000 Btu/h)	100	100	98.8	97.5	96.3	95.1	93.9	92.7	91.5	90.3	89.1	87.9	86.7	85.5	84.3	83.1
<i>Heating Capacity Coefficient Factor.</i>																	
Rate of Capacity Change (%)	LC188HHV4 (18,000 Btu/h)	100	100	100	100	100	99.4	98.8	98.2	97.5	96.9	96.3	-	-	-	-	-
	LC249HHV (24,000 Btu/h)	100	100	100	100	100	99.4	98.8	98.2	97.5	96.9	96.3	-	-	-	-	-
	LC369HHV (36,000 Btu/h)	100	100	100	100	100	99.3	98.5	97.8	97.0	96.3	95.5	94.8	94.0	93.3	92.5	91.8
	LC429HHV (42,000 Btu/h)	100	100	98.8	97.5	96.3	95.1	93.9	92.7	91.5	90.3	89.1	87.9	86.7	85.5	84.3	83.1
	LC489HHV (48,000 Btu/h)	100	100	98.8	97.5	96.3	95.1	93.9	92.7	91.5	90.3	89.1	87.9	86.7	85.5	84.3	83.1

Performance Data

Equivalent Piping Length for Piping Components

Table 46: Equivalent Piping Length for Elbows.

Component	Size (Inches)													
	1/4	3/8	1/2	5/8	3/4	7/8	1	1-1/8	1-1/4	1-3/8	1-1/2	1-5/8	1-3/4	2-1/8
Elbow (ft.)	0.5	0.6	0.7	0.8	1.2	1.3	1.5	1.6	1.8	2.0	2.1	2.3	2.5	2.8

Altitude Correction Factor

The impact of air density must be considered on systems installed at a significant altitude above sea level, therefore, locally accepted altitude correction factors must be applied.

Defrost Correction Factor for Heating Operation

The outdoor unit heating capacity will need to be adjusted for frost accumulation on air-cooled systems. If design day conditions are below the dewpoint of the surrounding air, frost will not be a problem and no correction factor is needed. In certain weather conditions, however, frost will form and accumulate on the air-cooled outdoor unit coil and impact the coils ability to transfer heat. If significant frost accumulates on the outdoor unit coil, a defrost algorithm will start automatically. The timing between defrost periods is determined by the system's ability to achieve a target head pressure value.

Capacity and AHRI ratings tables do not factor in capacity reduction when frost has accumulated on the condenser coil, nor during defrost operation.

Integrated heating capacity values can be obtained using the formula: **Table 47: Outdoor Unit Frost Accumulation Factor (Heating)¹.**

$$A = B \times C$$

Where:

A = Integrated Heating Capacity.

B = Value found in the Capacity Table.

C = Correction Factor for Frost Accumulation Factor (from table at right).

Entering DB (°F)	19.4	23.0	26.6	32.0	37.4	41.0	44.6
Derate factor	0.98	0.95	0.93	0.86	0.93	0.96	1.0

¹At 85% outdoor air relative humidity.

The frost accumulation factor does not account for effects of snow accumulation restricting airflow through the outdoor unit coil.

Note:

There will be a temporary reduction in capacity when frost / ice accumulates on the outside surface of the outdoor unit heat exchanger. The level of capacity reduction depends on a number of factors, for example, outdoor temperature (°F DB), relative humidity (RH), and the amount of frost present.

Check the Indoor and Outdoor Unit Selection(s)

Compare the corrected cooling and heating capacities to the load calculations. Is each capacity sufficient for the zone it serves?

For each indoor unit, the corrected capacity must be at least equal to the total of the cooling design load (plus ventilation load, if applicable) for the space(s) served by the indoor unit. For each indoor unit, the corrected capacity also must be at least equal to the total of the heating design load (plus ventilation load, if applicable) for the space(s) and / or thermal zones served by the indoor unit.

The outdoor unit selected must be large enough to offset the total cooling load for all spaces it serves (account for ventilation air cooling load if the ventilation air has not been pretreated to room neutral conditions). The outdoor unit must also be large enough to offset the total heating load for all spaces it serves.

If the corrected heating capacity ratio exceeds 100%, reselect the equipment, or change the system design by moving some of the load to another system.

System Sizing Check Formulas

1. Outdoor Unit Rated Capacity.

$Q_{odu(rated)}$ (From capacity tables).

2. Outdoor Unit Capacity at T_i , T_o Temperature.

$Q_{odu(T_i, T_o)}$ (From capacity tables).

3. Outdoor Unit Capacity Coefficient Factor.

$F_{(T_i, T_o)} = Q_{odu(T_i, T_o)} / Q_{odu(rated)}$

4. Piping Correction Factor (From Capacity Coefficient Factor Tables).

$F_{(length)}$ for each piping length

5. Individual Indoor Unit Combination Capacity.

$Q_{idu(combi)} = Q_{odu(rated)} \times Q_{idu(rated)} / Q_{idu(rated-total)}$

6. Individual Indoor Unit Actual Capacity.

$Q_{idu(actual)} = Q_{odu(combi)} \times F_{(T_i, T_o)} \times F_{(length, altitude)}$

Conclusions and Recommendations

- Understand the design safety factors.
- Reference load calculations for actual cooling and heating capacities (applies in 99% of applications – consider total load when latent load is greater than 30%).
- Verify that the sensible load of the zone is satisfied.
- Use caution when sizing to meet listed capacity specifications for the scheduled manufacturer's equipment.

If further system design assistance is needed, or you have a unique application you would like to discuss, contact your LG sales rep.

APPLICATION GUIDELINES

Placement Considerations on page 62

Installing Outdoor Units Indoors on page 70

Refrigerant Piping Design on page 73

Selecting the Best Location for the Indoor Unit

⚠ WARNING

The unit should not be installed where sulfuric acid and flammable or corrosive gases are generated, vented into, or stored. There is risk of fire, explosion, and physical injury or death.

Note:

Do's

Select a location for installing the indoor units that will meet the following conditions:

- Place the unit where air circulation will not be blocked.
- Locate the indoor unit in a location that is level, and where it can be easily connected to the outdoor unit.
- Place the unit in a location where condensation drainage can be conveniently routed away.
- Include enough space around the indoor unit so that it is accessible for maintenance and service purposes.
- Place the unit in a location where electrical noise / electromagnetic waves will not impact operation. Maintain proper distances between the indoor units and electric wires, audio and visual appliances, breaker / circuit panels, etc.
- Place in an area that is level and with enough strength to bear the weight of the indoor unit(s).

⊘ Do Not's

- No obstacles to air circulation around the unit; keep proper distances from ceilings, doorways, floor, walls, etc.
- The unit should not be installed near a heat or steam source, or where considerable amounts of oil, iron powder, or flour are used.
- The unit should not be installed where sulfuric acid and flammable or corrosive gases are generated, vented into, or stored.
- Avoid installing the unit near high-frequency generators or near any equipment that generates an electromagnetic field (minimum 3-1/3 feet away).

Figure 41: 2 x 2 Cassette Ceiling Opening Dimensions and Bolt Locations.

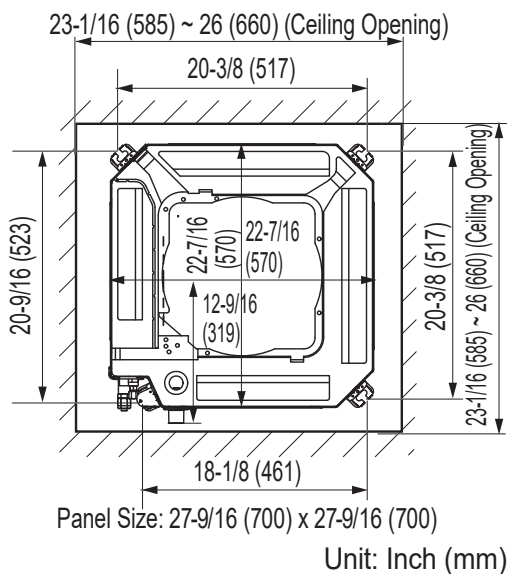

Figure 40: Indoor Unit Clearance Requirements.

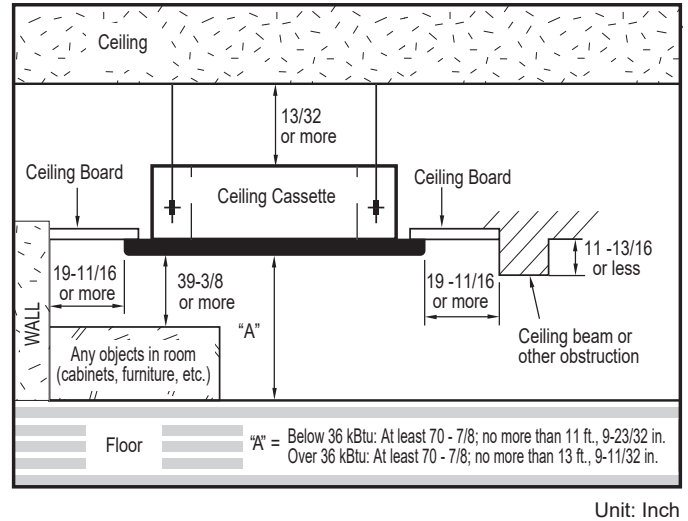
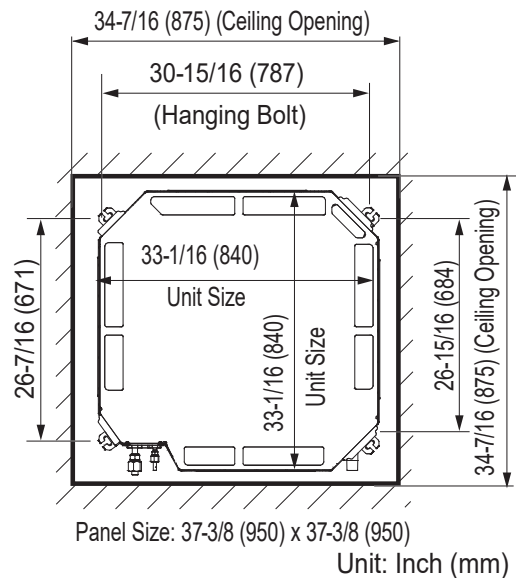

Figure 42: 3 x 3 Cassette Ceiling Opening Dimensions and Bolt Locations.



Note:

- Indoor units (IDUs) should not be placed in an environment where the IDUs will be exposed to harmful volatile organic compounds (VOCs) or in environments where there is improper air make up or supply or inadequate ventilation. If there are concerns about VOCs in the environment where the IDUs are installed, proper air make up or supply and / or adequate ventilation should be provided. Additionally, in buildings where IDUs will be exposed to VOCs consider a factory-applied epoxy coating to the fan coils for each IDU.
- If the unit is installed near a body of water, certain components are at risk of being corroded. Appropriate anti-corrosion methods should be taken for the unit and all components.

The unit will be damaged, will malfunction, and / or will not operate as designed if installed in any of the conditions listed.

Installing in a High or Dropped Ceiling

High or dropped ceilings, often found in commercial buildings and offices, will cause a wide temperature differentiation. To countermeasure:

- Change the indoor unit mode selection to allow for higher ceilings (see table).
- Install an air circulator.
- Set the air discharge outlet so that heated air flows in a downward direction.
- Use a dual door system to protect the building gate or exit.

Table 48: Indoor Unit High Ceiling Mode Selection Options (LCN188HV4).

Ceiling Height	Mode Selection
≤7-1/2 feet	Low Ceiling
7-1/2 feet to 8-7/8 feet	Standard
8-7/8 feet to 10-3/16 feet	High Ceiling
10-3/16 feet to 11-13/16 feet	Super High Ceiling

Table 49: Indoor Unit High Ceiling Mode Selection Options (LCN249HV, LCN369HV, LCN429HV, LCN489HV).

Ceiling Height	Mode Selection
≤8-7/8 feet	Low Ceiling
8-7/8 feet to 10-1/2 feet	Standard
10-1/2 feet to 11-13/16 feet	High Ceiling
11-13/16 feet to 16-3/8 feet	Super High Ceiling

Installing in an Area Exposed to Unconditioned Air

In some installation applications, areas (floors, walls) in some rooms will be exposed to unconditioned air (room will be above or next to an unheated garage or storeroom). To countermeasure:

- Verify that carpet is or will be installed (carpet will increase the temperature by three degrees).
- Add insulation between the floor joists.
- Install radiant heat or another type of heating system to the floor.

Installing in an Area with High Humidity Levels

If the environment is prone to humidity levels of 80% or more (near the ocean, lakes, etc.) or where steam could collect in the plenum:

- Install additional insulation to the indoor unit (glass wool insulation >13/32 inches thick).
- Install additional insulation to the refrigerant piping (insulation >13/16 inches thick).
- Seal all gaps between the indoor unit and the ceiling tiles (make the area air tight) so that humidity does not transfer from the plenum to the conditioned space. Also, add a ceiling grille for ventilation.



PLACEMENT CONSIDERATIONS

LGRED[®]

Outdoor Unit

Selecting the Best Location for the Outdoor Unit

⚠ DANGER

- ⓧ Do not install the unit in an area where combustible gas will generate, flow, stagnate, or leak. These conditions can cause a fire, resulting in bodily injury or death.
- ⓧ Do not install the unit in a location where acidic solution and spray (sulfur) are often used as it can cause bodily injury or death.
- ⓧ Do not use the unit in environments where oil, steam, or sulfuric gas are present as it can cause bodily injury or death.

⚠ CAUTION

When deciding on a location to place the outdoor unit, be sure to choose an area where run-off from defrost will not accumulate and freeze on sidewalks or driveways, which will create unsafe conditions. Properly install and insulate any drain hoses to prevent the hose from freezing, cracking, leaking, and causing unsafe conditions from frozen condensate.

⚠ WARNING

Install a fence to prevent vermin from crawling into the unit or unauthorized individuals from accessing it. Vermin and unauthorized individuals will cause a fire, electric shock, physical injury or death. Follow the placement guidelines set forth in "Clearance Requirements".

Note:

Install a fence to prevent vermin from crawling into the unit or unauthorized individuals from accessing it. Vermin and unauthorized individuals will damage the unit. Follow the placement guidelines set forth in "Clearance Requirements".

Select a location for installing the outdoor unit that will meet the following conditions:

- Where there is enough strength to bear the weight of the unit.
- A location that allows for optimum air flow and is easily accessible for inspection, maintenance, and service.
- Where piping between the outdoor unit and indoor unit is within allowable limits.
- Include space for drainage to ensure condensate flows properly out of the unit when it is in heating mode. ⓧ Avoid placing the outdoor unit in a low-lying area where water could accumulate.
- If the outdoor unit is installed in a highly humid environment (near an ocean, lake, etc.), ensure that the site is well-ventilated and has a lot of natural light (Example: Install on a rooftop).

ⓧ Do Not's

- Where it will be subjected to direct thermal radiation from other heat sources, or an area that would expose the outdoor unit to heat or steam like discharge from boiler stacks, chimneys, steam relief ports, other air conditioning units, kitchen vents, plumbing vents, and other sources of extreme temperatures.
- Where high-frequency electrical noise / electromagnetic waves will affect operation.
- Where operating sound from the unit will disturb inhabitants of surrounding buildings.
- Where the unit will be exposed to direct, strong winds.
- Where the discharge of one outdoor unit will blow into the inlet side of an adjacent unit (when installing multiple outdoor units).

Outdoor Unit Condensate Drain Piping

Outdoor unit requires condensate drain piping. Condensate drain pipe is constructed with materials approved by local code. See pages 67-69 for information in reference to outdoor unit placement.

Planning for Snow and Ice

To ensure the outdoor unit operates properly, certain measures are required in locations where there is a possibility of heavy snowfall or severe windchill or cold:

1. Prepare for severe winter wind chills and heavy snowfall, even in areas of the country where these are unusual phenomena.
2. Position the outdoor unit so that its airflow fans are not buried by direct, heavy snowfall. If snow piles up and blocks the airflow, the system will malfunction.
3. Remove any snow that has accumulated four (4) inches or more on the top of the outdoor unit.
4. In climates that will experience significant snow buildup, mount the outdoor unit on a raised, field-provided platform or stand. The raised support platform must be high enough to allow the unit to remain above possible snow drifts, and must be higher than the maximum anticipated snowfall for the location.
5. Design the mounting base to prevent snow accumulation on the platform in front or back of the unit frame.
6. Provide a field fabricated snow protection hood to keep snow and ice and/or drifting snow from accumulating on the coil surfaces.
7. To prevent snow and heavy rain from entering the outdoor unit, install the condenser air inlets and outlets facing away from direct winds.
8. Consider tie-down requirements in case of high winds or where required by local codes.

Planning for Snow and Ice, continued.

⚠ CAUTION

When deciding on a location to place the outdoor unit, be sure to choose an area where run-off from defrost will not accumulate and freeze on sidewalks or driveways, which will create unsafe conditions. Properly install and insulate any drain hoses to prevent the hose from freezing, cracking, leaking, and causing unsafe conditions from frozen condensate.

Underground Refrigerant Piping

Refrigerant pipe installed underground must be routed inside a vapor tight protective sleeve to prevent insulation deterioration and water infiltration. Refrigerant pipe installed inside underground casing must be continuous without any joints. Underground refrigerant pipe must be located at a level **below the frost line**.

Table 50: Utility Conduit Sizes (Inches).

Liquid Pipe ¹	Vapor Pipe ¹			
	3/8 (2.0 ^{2,5})	1/2 (2.0 ^{2,5})	5/8 (2-1/8 ^{2,5})	3/4 (2-1/4 ^{2,5})
1/4 (1.0) ³	4	4	4	4
3/8 (1-1/8) ³	4	4	4	5
1/2 (1-1/2) ⁴	5	5	5	5
5/8 (1-5/8) ⁴	5	5	5	5
3/4 (1-3/4) ⁴	5	5	5	5

¹OD pipe diameter in inches; Values in parenthesis () indicate OD of pipe with insulation jacket.
²Diameter of pipe with insulation. Thickness of pipe insulation is typical. Actual required thickness will vary based on surrounding ambient conditions and must be calculated and specified by the design engineer.
³Insulation thickness (value in parenthesis) = 3/8 inch.
⁴Insulation thickness (value in parenthesis) = 1 inch.
⁵Insulation thickness (value in parenthesis) = 3/4 inch.

Tie-Downs and Lightning Protection

Tie-Downs

- The strength of the roof must be checked before installing the outdoor units.
- If the installation site is prone to high winds or earthquakes, when installing on the wall or roof, securely anchor the mounting base using a field-provided tie-down configuration approved by a local professional engineer.
- The overall tie-down configuration must be approved by a local professional engineer.

Note:

Always refer to local code when using a wind restraint system.

Lightning Protection

- To protect the outdoor unit from lightning, it must be placed within the specified lightning safety zone.

Table 52: Safety Zone Specifications.

Building Height (feet)	66	98	148	197
Protection Angle (°)	55	45	35	25

- Power cable and communication cable must be installed five (5) feet away from lightning rod.
- A high-resistance ground system must be included to protect against induced lightning or indirect strike.

Note:

If the building does not include lightning protection, the outdoor unit will be damaged from a lightning strike. Inform the customer of this possibility in advance.



Figure 43: Typical Arrangement of Single Zone Refrigerant Pipe and Cable(s) in a Utility Conduit.

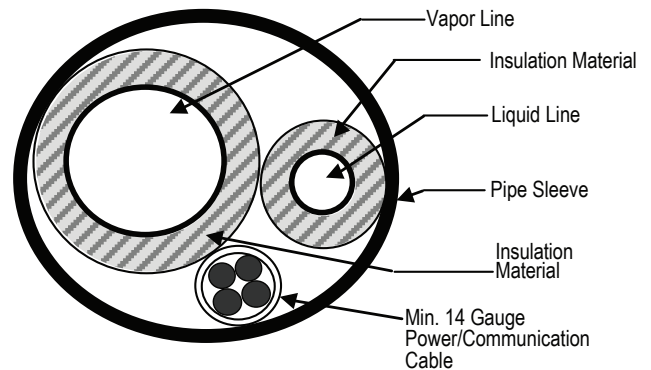
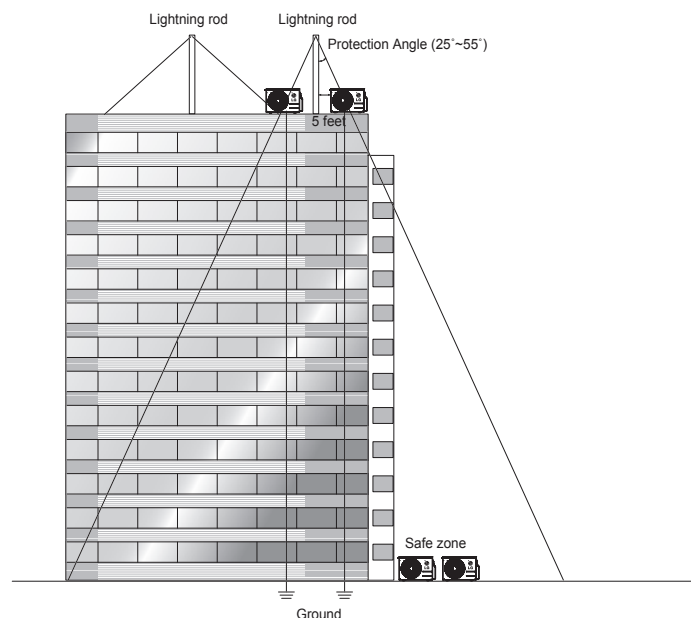

Table 51: Outdoor Unit Refrigerant Pipe Connections.

Model	Liquid Conn. (inches)	Vapor Conn. (inches)
LC188HHV4	3/8	5/8
LC249HHV, LC369HHV, LC429HHV, LC489HHV	3/8	5/8

Figure 44: Lightning Protection Diagram.



Oceanside Applications

Use of a Windbreak to Shield from Sea Wind

Note:

Ocean winds will cause corrosion, particularly on the condenser and evaporator fins, which, in turn could cause product malfunction or inefficient performance.

- Avoid installing the outdoor unit where it would be directly exposed to ocean winds.
- Install the outdoor unit on the side of the building opposite from direct ocean winds.
- Select a location with good drainage.
- Periodically clean dust or salt particles off of the heat exchanger with water.
- If the outdoor unit must be placed in a location where it would be subjected to direct ocean winds, install a concrete windbreak strong enough to block any winds.
- Windbreak must be more than 150% of the outdoor unit's height. There must be 2 to 3-1/2 inches of clearance between the outdoor unit and the windbreaker for purposes of air flow.

Use of a Building to Shield from Sea Wind

If a windbreak is not possible, a building or larger structure must be used to shield the outdoor unit from direct exposure to the sea wind. The unit must be placed on the side of the building directly opposite to the direction of the wind as shown in the figure at right.

Figure 45: Oceanside Placement Using Windbreak.

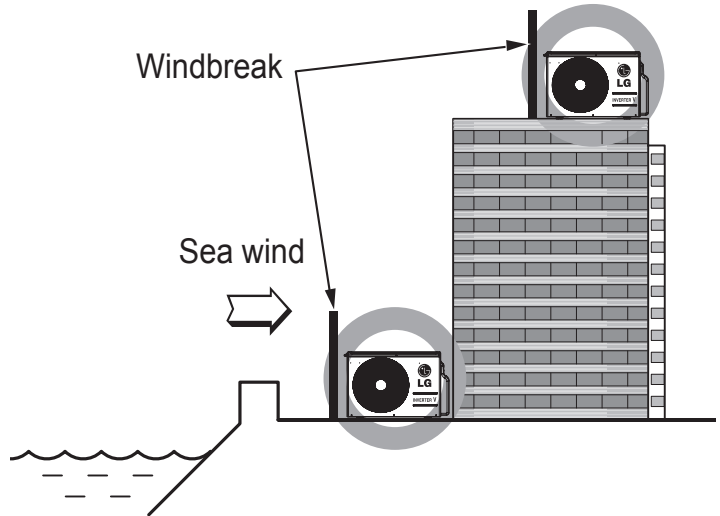

Note:

Additional anti-corrosion treatment will need to be applied to the outdoor unit at oceanside locations.

Figure 46: Placement Using Building as Shield.

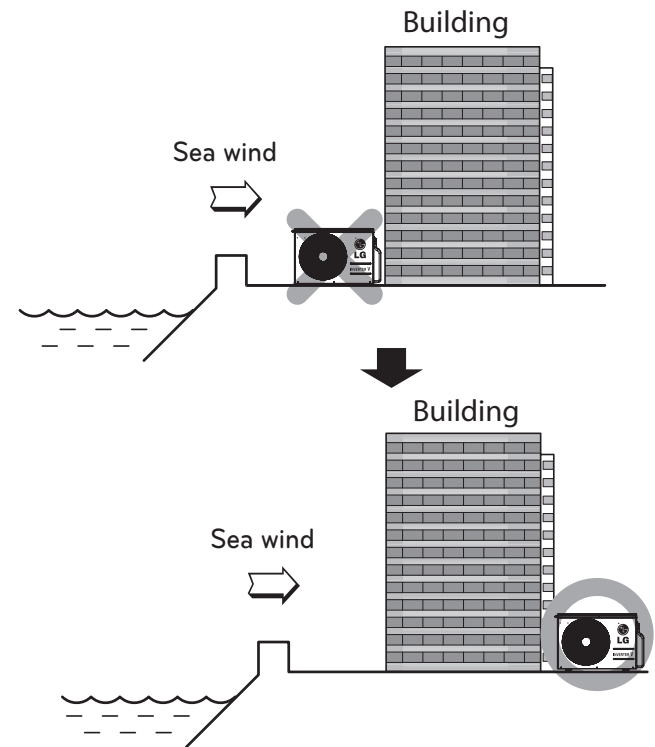

Minimum Allowable Clearance and Service Access Requirements

Proper clearance for the outdoor unit coil is critical for proper unit operation. When installing the outdoor unit, consider service, inlet and outlet and minimum allowable space requirements as illustrated in the diagrams below and on the following pages.

- Include enough space for airflow and for service access. If installing multiple outdoor units, ⚠ avoid placing the units where the discharge of one unit will blow into the inlet side of an adjacent unit.
- If an awning is built over the unit to prevent direct sunlight or rain exposure, make sure that the discharge air of the outdoor unit isn't restricted.
- ⚠ No obstacles to air circulation around the unit; keep proper distances from ceilings, fences, floor, walls, etc. (Install a fence to prevent pests from damaging the unit or unauthorized individuals from accessing it.)

Outdoor Unit (18,000 and 24,000 Capacity) Service Access and Allowable Clearances

Specific clearance requirements in the diagram below are for 18,000 and 24,000 Btu/h capacities. The figure below shows the overall minimum clearances that must be observed for safe operation and adequate airflow around the outdoor unit.

When placing the outdoor unit under an overhang, awning, sunroof or other "roof-like structure", observe the clearance requirements (as shown in Cases 1 and 2) for height in relation to the unit. To have successful service access to the outdoor unit, see the figure below for minimum spacing. When installing multiple outdoor units, see Cases 4 and 5 for correct spacing requirements.

Note:

If the outdoor unit is installed between standard and minimum clearances, capacity decreases approximately 10%.

Figure 47: 18,000 and 24,000 Capacity Outdoor Unit Service Access and Allowable Clearances Diagram.

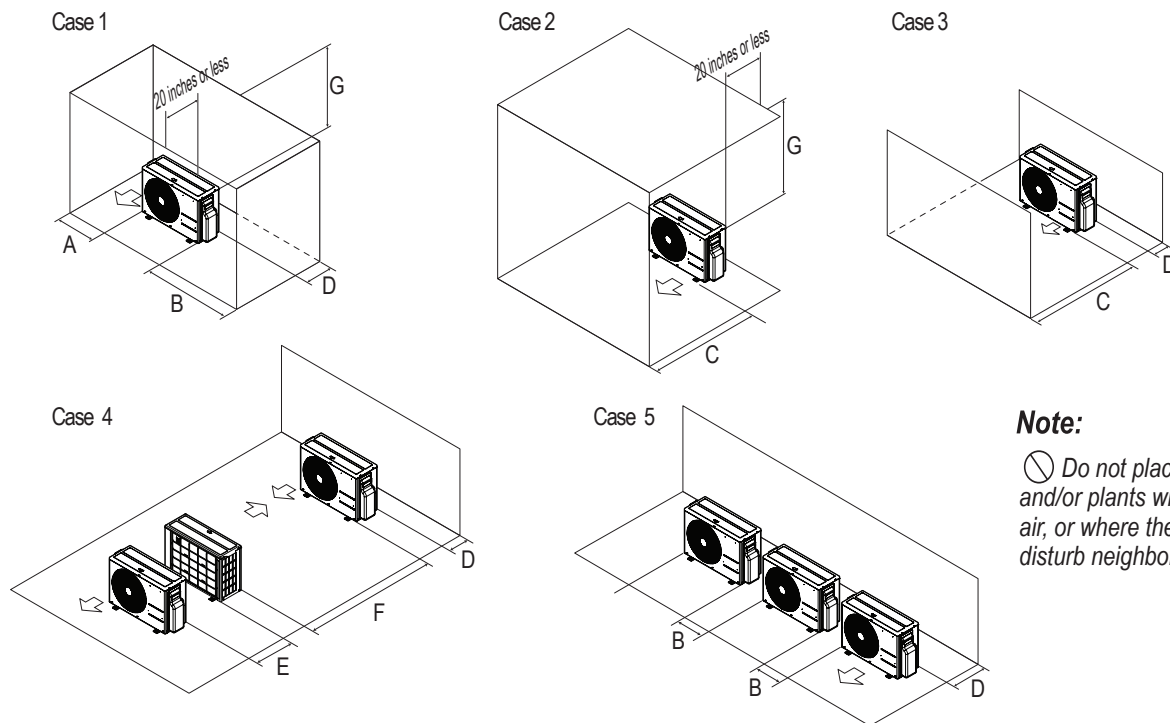

Note:

⚠ Do not place the unit where animals and/or plants will be in the path of the warm air, or where the warm air and/or noise will disturb neighbors.

Table 53: 18,000 to 24,000 Outdoor Unit Service Access and Allowable Clearances Diagram Legend.

Unit: Inch		A	B	C	D	E	F	G
Case 1	Standard	12	24	-	12	-	-	-
	Minimum	4	10	-	4	-	-	40
Case 2	Standard	-	-	20	-	-	-	-
	Minimum	-	-	14	-	-	-	40
Case 3	Standard	-	-	20	12	-	-	-
	Minimum	-	-	14	4	-	-	-
Case 4	Standard	-	-	-	12	24	-	-
	Minimum	-	-	-	4	8	79	-
Case 5	Standard	-	24	-	12	-	-	-
	Minimum	-	10	-	4	-	-	-

PLACEMENT CONSIDERATIONS



Outdoor Unit

Outdoor Unit (36,000 to 48,000 Btu/h Capacity) Service Access and Allowable Clearances

When installing the outdoor unit, consider service, inlet, and outlet, and minimum allowable space requirements as illustrated in the following diagrams.

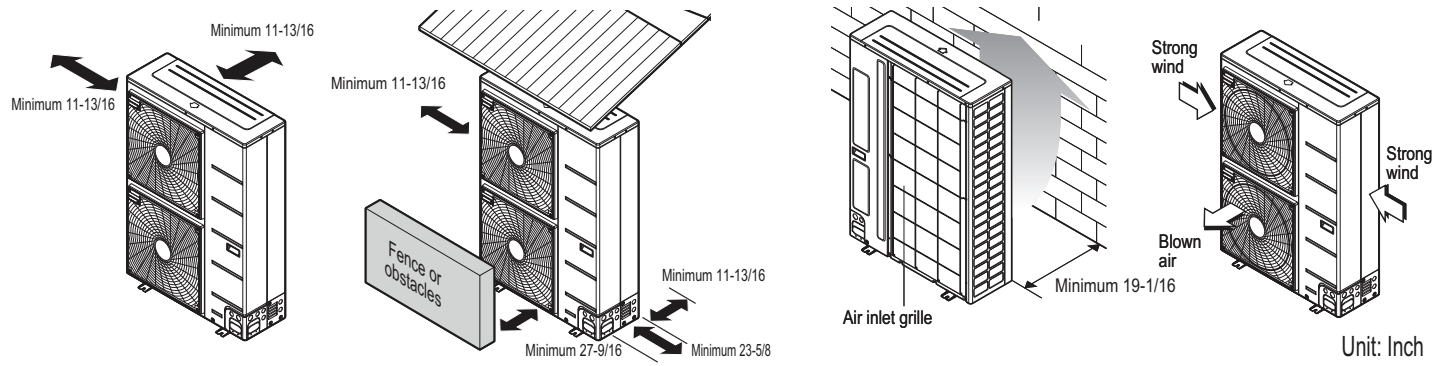

Ensure that the space at the back of the outdoor unit is a minimum of 11-13/16 inches, and include a minimum of 23-5/8 inches at the right side of the unit for service.

If the outdoor unit discharge side faces a wall, include a minimum of 19-11/16 inches between the outdoor unit and the wall. Install the outdoor unit so that the discharge port is set at a right angle to the wind direction.

Clearance Requirements when Different Obstacles are Present (Unit: Inch).

Obstacle on the suction side only.

Obstacles on the suction side and on both left and right sides.

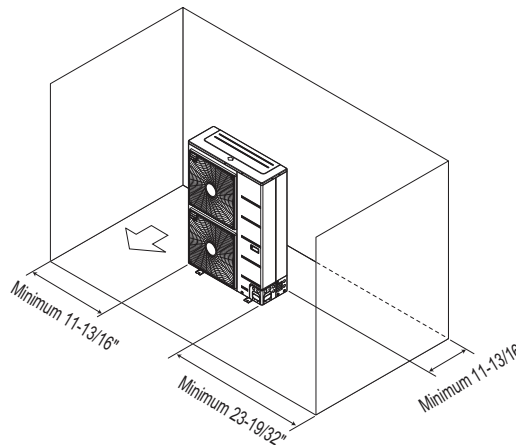
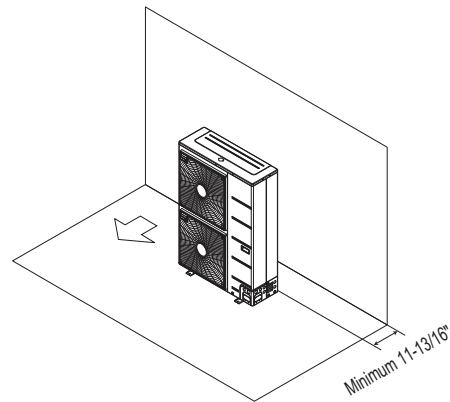

Obstacles above and on the air intake side. Obstacles above, on the air intake side, and on both left and right sides

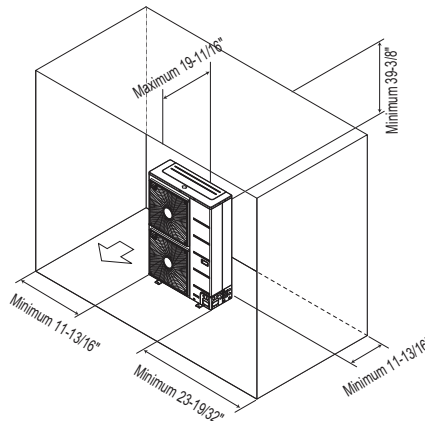
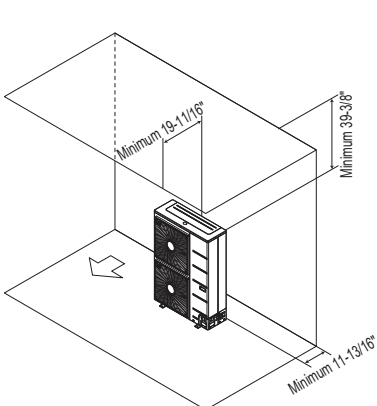

Obstacle just on the air discharge side.

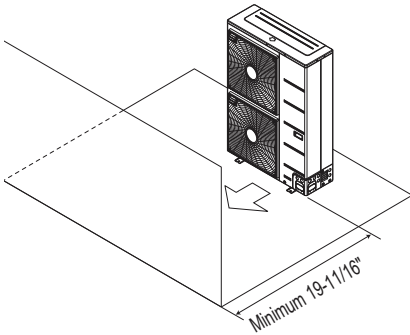

Obstacles above and on the air discharge side.

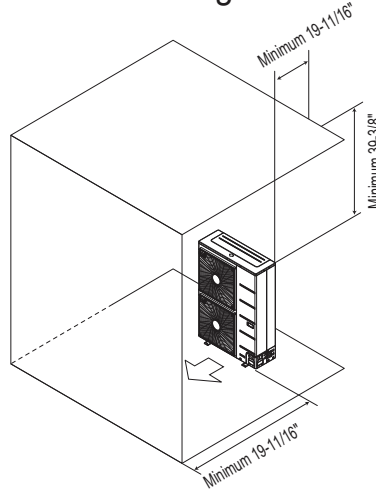

Where there are obstacles on both suction and discharge sides (discharge side obstacle is higher than the outdoor unit).

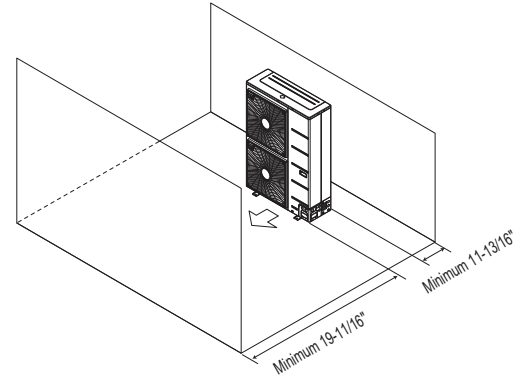

Where there are obstacles above, and on both suction and discharge sides (discharge side obstacle is higher than the outdoor unit).

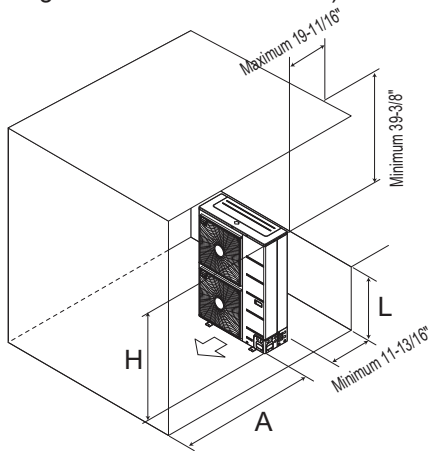
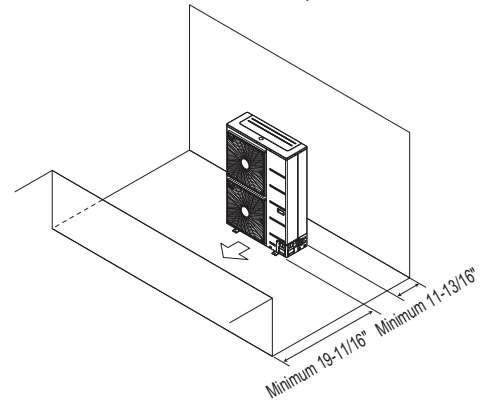

Table 54: Ratio among H, A, and L.

	L	A
$L \leq H$	$0 < L \leq 1/2 H$	29-1/32 inches
	$1/2 H < L$	39-3/8 inches
$H < L$	Set Stand as: $L \leq H$	

If a stand is necessary, it should be contained (not open frame) to prevent the discharge air from short cycling.

Where there are obstacles on both suction and discharge sides (discharge side obstacle is lower than the outdoor unit).



Where there are obstacles above, and on both suction and discharge sides (discharge side obstacle is lower than the outdoor unit).

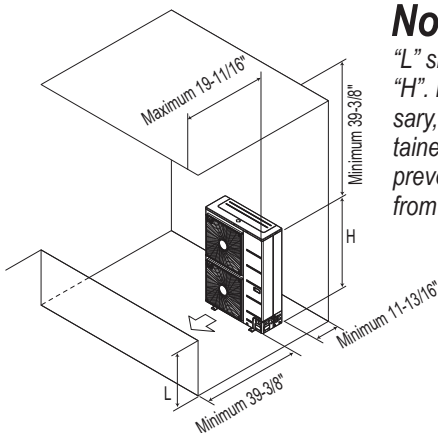

Note:

"L" should be lower than "H". If a stand is necessary, it should be contained (not open frame) to prevent the discharge air from short cycling.

Series installation

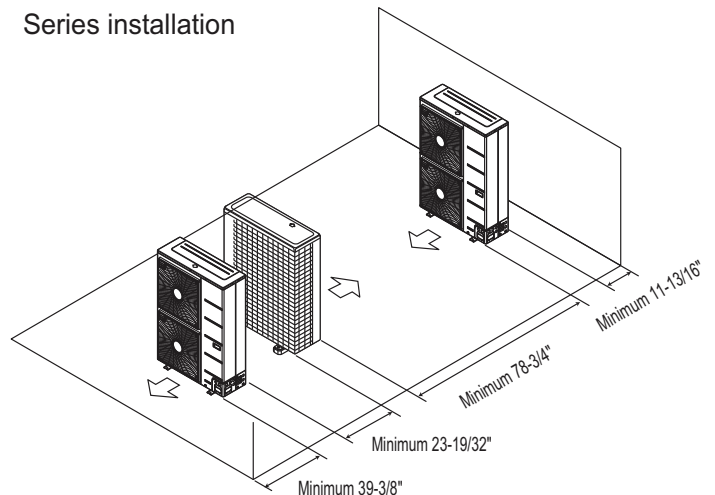

Installing Outdoor Units Indoors

Single Zone Cassette outdoor units are engineered to be mounted outdoors and include technology designed to minimize the negative effects of winter weather's freezing rain, sleet, and snow. Some building projects, however, necessitate placing the HVAC outdoor units indoors:

- Lack of ground space.
- Lack of an appropriate outdoor location that meets system design requirements.
- When mounting on the roof is not an option due to a lack of roof space.
- Roof warranty will be voided if mechanical equipment is placed on the membrane.
- On retrofit projects, a former chiller / boiler / air handler equipment room, mechanical area, or penthouse already exists.
- To curtail the potential need for redundant zone heating devices such as wall-fin radiators or duct heaters.
- In extremely cold environments where there is a significant amount of run-time at temperatures well below freezing outside the outdoor unit ambient air temperature range published in this engineering manual.

Benefits of Installing Outdoor Units Indoors

- Shelters the outdoor unit from direct exposure to prevailing winds that decrease the heating capability of the outdoor unit.
- Protects equipment from freezing precipitation and / or potential ice build-up that could hinder unit operation.
- Maintains coil heat transfer efficiency by reducing the number of and shortening the cycle time for defrost operation.
- Easier maintenance and servicing during inclement weather.
- When mounted in a fully enclosed space, limiting the ambient air temperature will allow the Single Zone Cassette system designer to eliminate oversizing.
- The outdoor unit to compensate for loss of capacity at low ambient temperatures.
- Will also curtail the need to provide inefficient redundant zone heating devices such as wall-fin radiators and second-stage ancillary heating devices.

Design Considerations Include:

- Enclosure types and elements such as louvers (see next page), rain hoods, dampers and controls, heating methods and sizing of heating devices.
- Heating strategies.
- Duct design.
- Condensate handling.

General Guidelines

- Follow ASHRAE 62.1 design guidelines.
- Depending on the project / application, a roof over the outdoor units in combination with a wind break will be all that is necessary.
- Consider the potential for snow accumulation near louvers / roof openings. Outside air intakes and discharge ducts/louvers must be engineered to clear anticipated snow accumulation levels by at least one (1) foot.
- In situations where operation is anticipated at temperatures lower than the product's minimum operating temperature, ancillary heat must be provided to heat the outdoor unit coils to ensure continuous compressor operation and heating.

It will be necessary to use a field-fabricated air guide to prevent discharge air from short-cycling back to the coil inlet.

- Consider the direction of prevailing winds and opening placement. If possible, locate inlet openings upwind of discharge openings and other exhaust outlets.
- When inlet and outlet openings are placed on the same wall, minimum distance between the two openings must be approximately three (3) feet (minimum distance varies significantly with variations in outlet opening face velocity).
- If roof-mounted ventilation openings are used, strategically locate the inlet ventilation opening(s) upwind of the outlet opening(s).
- Discharge and supply ductwork must be designed to avoid weather related long periods of water entrainment and the potential for microbial growth.

Provide a means to drain the condensate generated during heating mode and defrost cycle in addition to rainwater that infiltrates the inlet louver enclosed area.

- Install a field-provided drain pan under the outdoor units and provide a path to a nearby floor drain.
- If the ambient air temperature is expected to drop below 32°F in the enclosure, heat the bottom surface of the pan, drain line, and floor drain so that the condensate does not freeze before reaching the drain.

⚠ CAUTION

When deciding on a location to place the outdoor unit, be sure to choose an area where run-off from defrost will not accumulate and freeze on sidewalks or driveways which will create unsafe conditions.

Allow for ventilation intake and exhaust air based on maximum outdoor unit fan capacity.

- Select the size, type and orientation of architectural louvers with adequate “net free area” face velocity to ensure the total external static pressure from the outdoor unit fan does not exceed design limitations (see specification data tables).
- No obstructions must be placed in front of the louver that could hamper the free flow (throw) of air.
- Roof top openings and / or discharge and supply louvers must be equipped with screens to prevent bird and insect infiltration.

Note:

For louver recommendations, see below and on the next page.

As always, the best solution for each project balances acceptable heating performance (considering local weather conditions), capital costs, life cycle energy consumption, and limitations set forth by local building codes.

Louver Recommendations for Outdoor Unit Enclosure

1. Outdoor Unit Enclosure: Manual Door Open Type.
2. Louver Angle: No More Than 15° Horizontally.
3. Space Between Louvers: More than 4 inches (Recommend).
4. Louver Shape: Wing or Plane Type.

Note:

- Open Rate and Inlet must be taken into consideration when designing the louvered outdoor unit enclosure.
- Do not use “S” type louvers.

Note:

If the Louver Open Rate is Too Small

1. Noise can occur because of the increased air velocity passing through the louver blade.
2. Noise can occur from louver blade vibrations.
3. A drop in outdoor unit fan performance (excess static pressure can cause a drop in outdoor unit performance and heat exchanger efficiency).
4. If the louver open rate is too small or there is insufficient air flow exchange, the air conditioner might stop operating.

Figure 48: Louver Recommendations.

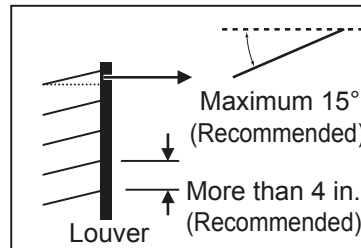
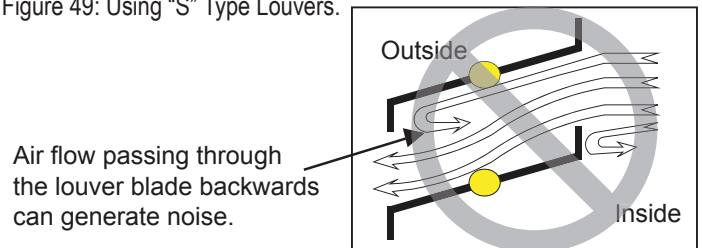

Figure 49: Using “S” Type Louvers.



PLACEMENT CONSIDERATIONS

Installing Outdoor Units Indoors

Open Rate by Louver Radian

Figure 50: Open Rate by Louver Radian Formula.

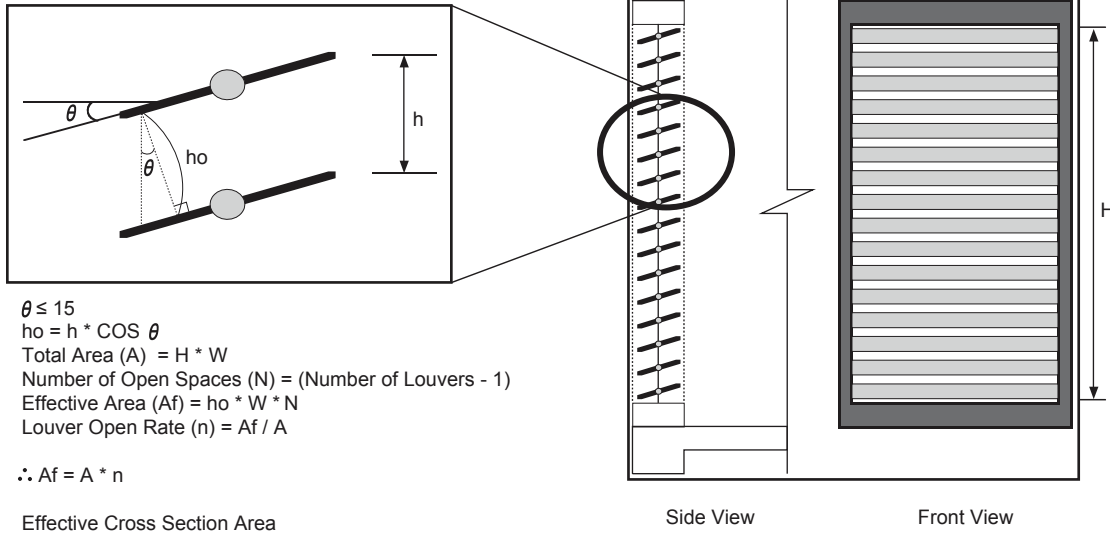

Confirming Air Flow Rate / Total Opening Rate

• Example: LSU180HSV5.

• Discharge Airflow Rate: 2,119 ft.³/min.

• Velocity of Outlet Air: 16.4 ft./s

• Velocity of Inlet Air: 8.2 ft./s

• Open Rate = 80% or More

$$\text{Open Rate} = \frac{\text{Effective Face Area (Af)}}{\text{Total Face Area (A)}}$$

• Inlet airflow must match or exceed discharge airflow.

• Separate inlet airflow from discharge airflow to prevent recirculation.

Figure 51: Example of Installing Outdoor Unit Indoors.

Louver Dimensions

Air Guide Duct on Outdoor Unit

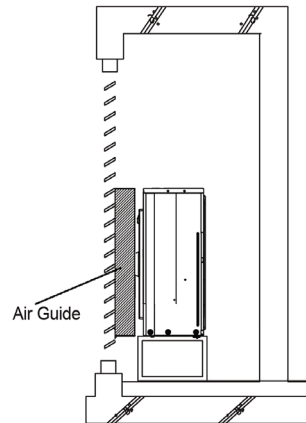
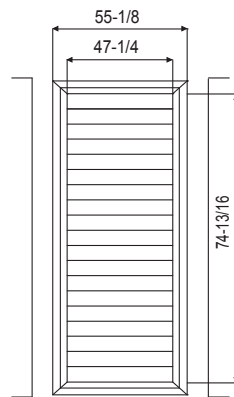

Outdoor Unit Dimensions

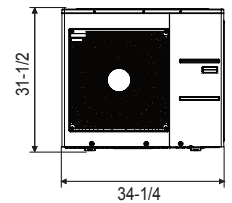

Unit: Inch

Formula

• Total Louver Dimension (Excluding Frame) (A) = 3.9 feet x 6.2 feet = 24.2 ft.²

• Area Blocked by Outdoor Unit (Discharge) (B) = 2.6 feet x 2.8 feet = 7.41 ft.²

• Inlet Louver Dimension (A - B) = 16.8 ft.²

• Equivalent Inlet Dimension (Open Rate 80%) = 16.8 ft.² x 0.8 = 13.44 ft.²

• Equivalent Inlet Airflow = 13.44 ft.² x 8.2 ft./s x 60 sec./min. = 6,612 ft.³/min.

• Equivalent Inlet Airflow / Discharge Airflow = 6,612 ft.³/min. / 2,119 ft.³/min. = 312% (Within Allowable Limits)

Device Connection Limitations

A single-zone system consists of one outdoor unit and one indoor unit. One of the most critical elements of a single-zone system is the refrigerant piping. If the connection piping is not within allowable limits, there will be reliability, performance, noise, and vibration issues. The table below lists pipe length limits that must be followed in the design of a Single Zone LGRED Four-Way Ceiling-Cassette refrigerant pipe system. See paragraph below for calculating additional refrigerant charge necessary for longer piping lengths. Refer to the figures for maximum length and elevation of piping.

Table 55: Single-Zone Four-Way LGRED Ceiling Cassette Refrigerant Piping System Limitations.

System Model Name		LC188HHV4, LC249HHV	LC369HHV, LC429HHV, LC489HHV
Pipe Sizes	Vapor	5/8	5/8
	Liquid	3/8	3/8
Pipe Length (ELF = Equivalent Length of Pipe)	Standard length (no add'l refrigerant)	24.9 feet	24.9 feet
	Longest total equivalent piping length	164 feet	246 feet
	Shortest total equivalent piping length	16.4	16.4
	Distance between fittings and indoor or outdoor units	≥20 inches	≥20 inches
Elevation (All Elevation Limitations are Measured in Actual Feet)	If outdoor unit is above indoor unit	98.4 feet	98.4 feet
	If outdoor unit is below indoor unit	98.4 feet	98.4 feet
Additional Refrigerant Needed (oz/ft)		0.43	0.43

Figure 52: Typical LC188HHV4 and LC249HHV System Layout.

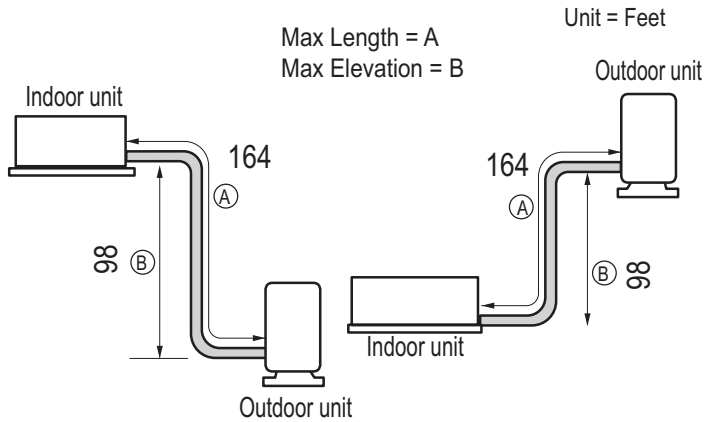
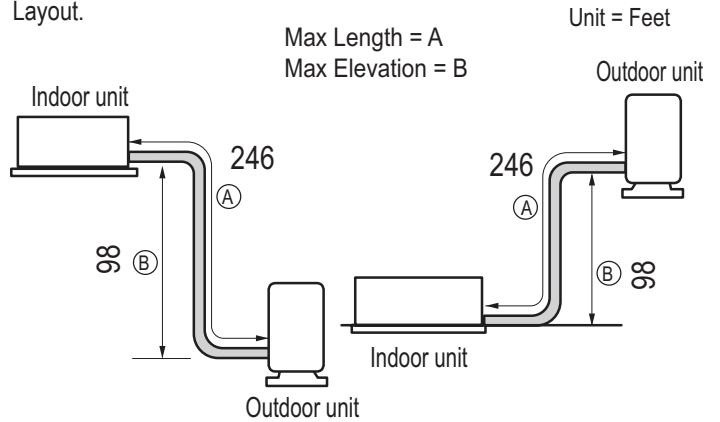

Figure 53: Typical LC369HHV, LC429HHV, and LC489HHV System Layout.



Additional Refrigerant Charge

Each outdoor unit is factory charged (nameplate charge) for the evaporator as well as a standard 24.9 foot line. Any time a line set is used longer than the standard 24.9 foot line set length, the refrigerant charge has to be adjusted.

The charge must be adjusted on 0.43 oz. of R410A per foot based on how many feet of piping are added. The factory charge accommodates pipe lengths up to the standard length without requiring refrigerant removal.

Note:

If the unit charge is unknown, reclaim, evacuate and weigh in the correct charge using the unit nameplate (capacity) charge adjusting for line sets longer than 24.9 ft. This will prevent any interruptions to the functioning of the unit and possible damage.

Example:

A 50 foot line set is used -- 25.1 additional feet x 0.43 oz. per foot. = Add 10.79 oz. of R410A.

Inverter

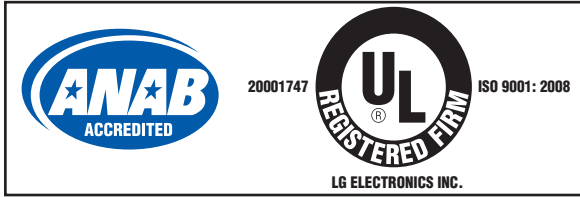

LG Electronics, U.S.A., Inc.
Air Conditioning Technologies
4300 North Point Parkway
Alpharetta, Georgia 30022
www.lghvac.com

