

OPERATION MANUAL

OFFICE PRO 63

Unit Serial Number Range: 0711XXXX630 to Present
(From July 2011 to Present)



**READ THIS MANUAL CAREFULLY FOR INSTRUCTIONS ON CORRECT
INSTALLATION AND USAGE AND READ ALL SAFEGUARDS**

SECCIÓN EN ESPAÑOL
SECTION EN FRANÇAIS
AVAILABLE AT WWW.MOVINCOOL.COM



MOVINCOOL®
THE #1 SPOT COOLING SOLUTION

SERIAL NUMBER LOCATION AND IDENTIFICATION

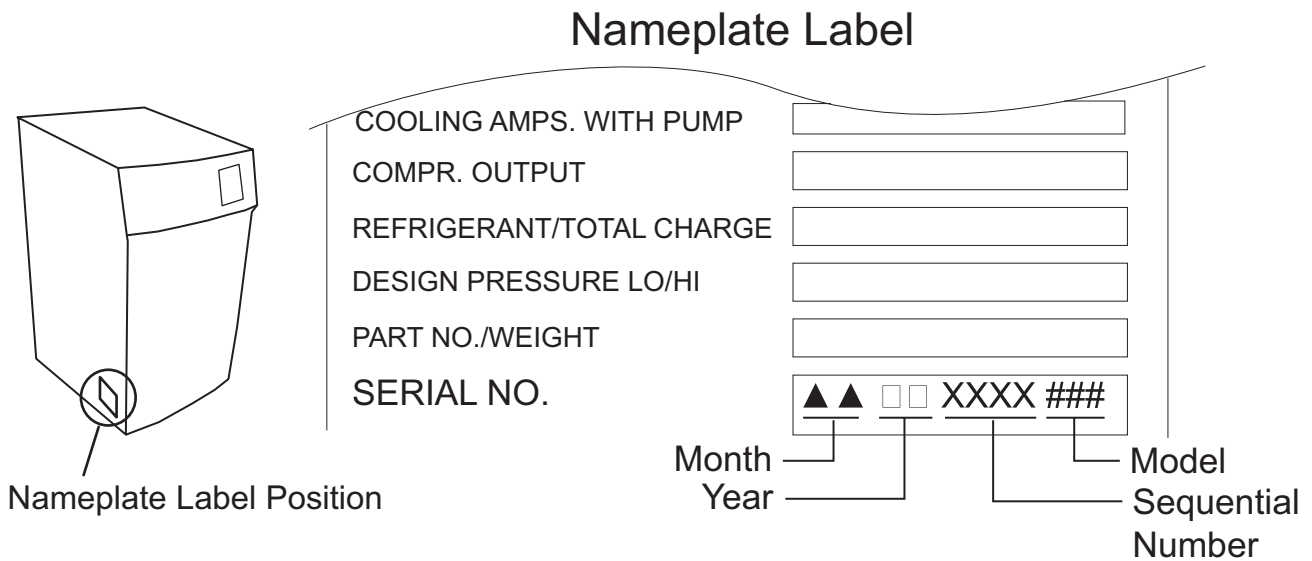

© 2013 DENSO PRODUCTS AND SERVICES AMERICAS, INC.
All rights reserved. This book may not be reproduced or copied, in whole or in part, without the written permission of the publisher. DENSO PRODUCTS AND SERVICES AMERICAS, INC. reserves the right to make changes without prior notice. MovinCool®, Office Pro®, and SpotCool® are registered trademarks of DENSO Corporation.

OPERATION MANUAL

OFFICE PRO 63

MOVIN**COOL**®
THE #1 SPOT COOLING SOLUTION

Table of Contents

SERIAL NUMBER LOCATION AND IDENTIFICATION	2
FOREWORD	5
Definition of Terms.....	5
GENERAL WARNINGS & CAUTIONS	6
INVENTORY	7
INSTALLATION	8
Choosing an Installation Site	8
Moving the Unit	9
Plugging in the Unit	10
Warning Signal Connection	11
Fire Alarm Control Panel Connection	12
FEATURES	13
OPERATION	14
Control Panel	14
LCD Indicators	15
Set Clock	16
Operating in COOL Mode	16
Operating in FAN ONLY Mode	17
Changing from FAN ONLY Mode to COOL Mode.....	17
Keypad Lock	17
How to Set a Program	18
How to View and Delete Program	19
How to Run and Stop Program	19
Operating Modes	20
Self-Diagnostic Codes	21
Empty the Drain Tank (If equipped).....	22
Drain Pump	23
HOSE INSTALLATION	24
DAILY INSPECTION & MAINTENANCE	25
Empty the Drain Tank	25
Clean the Air Filters	25
Filter Removal Method.....	25
Filter Cleaning Method.....	26
In-Season/Off-Season Inspection & Maintenance.....	26
TROUBLESHOOTING	27
TECHNICAL SPECIFICATONS	28

FOREWORD

Congratulations on purchasing the MovinCool portable air conditioner. This manual explains how to assemble, install and operate the MovinCool Office Pro 63 portable air conditioning unit. Please read this operation manual thoroughly to familiarize yourself with the features of the unit and to ensure years of reliable operation.

You may also find it useful to keep this operation manual on hand for reference. Components and/or procedures are subject to change without prior notice.

Definition of Terms



WARNING: Describes precautions that should be observed in order to prevent injury to the user during installation or unit operation.



CAUTION: Describes precautions that should be observed in order to prevent damage to the unit or its components, which may occur during installation or unit operation if sufficient care is not taken.

Note: Provides additional information that facilitates installation on unit operation.

GENERAL WARNINGS & CAUTIONS

1. All electrical work, if necessary, should only be performed by qualified electrical personnel. Repair to electrical components by non-certified technicians may result in personal injury and/or damage to the unit. All electrical components replaced must be genuine MovinCool parts, purchased from an authorized reseller.
2. The proper electrical outlet for MovinCool units must be equipped with a UL approved ground-fault breaker to prevent electrical shock from the unit.
3. The Office Pro 63 is equipped with a six (6) foot (1.8 meter) power cord. For replacement, fixed location (hard wire) or power cord lengthening (extension cord) cords are required, contact your reseller or a qualified electrician for approved replacement methods.
4. Never fold or place heavy objects on the power cord. This could result in damage to the power cord causing electrical shock or fire.
5. Do not place water or any other liquid on the unit. This can cause damage to the unit and increase the risk of electrical shock.
6. Do not sit or stand on the unit.

INVENTORY

After unpacking your MovinCool unit, please check to make sure you have the following items:

- 1. Office Pro 63 MovinCool Unit (1)**
- 2. Operation Manual / Product Registration (1)**

Note: If any of these items were not included in the box or appear damaged, please contact your MovinCool reseller for replacement.

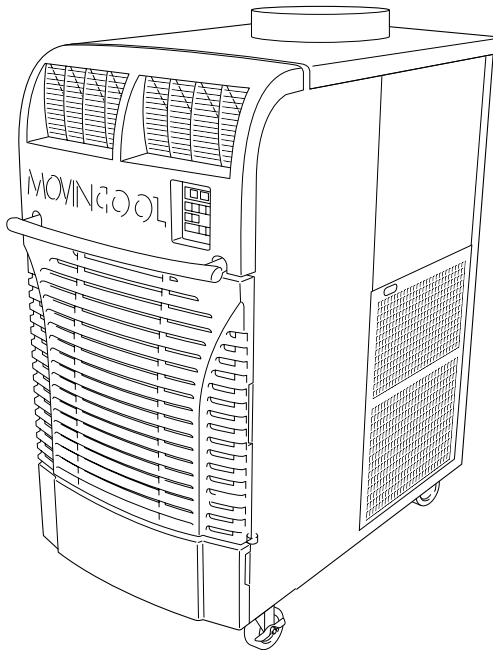

OFFICE PRO 63 MOVINCool UNIT



**OPERATION MANUAL /
PRODUCT REGISTRATION**

INSTALLATION

Choosing an Installation Site



CAUTION: Following are some precautions to consider before choosing your installation site. Please review carefully as improper installation may result in personal injury or damage to the unit.

1. Do not use the unit in areas where leakage of flammable gas may occur.
2. Do not use the unit in areas where it is exposed to rain or water.
3. Do not use the unit in an atmosphere of excessively corrosive gas or vapor.
4. Do not use in areas where the temperature is outside the allowable operating range.
5. Do not install the unit in sloping areas. The unit may move or topple over even if the casters are set to the LOCKED position.
6. Install the unit in areas that can with-stand the weight of the unit. The Office Pro 63 unit weighs approximately 739 lbs (335kg) (when the drain tank is full of water).
7. Allow 24 inches (610mm) of unobstructed airflow for both the air inlets and outlets.
8. Do not use the Office Pro 63 unit at condition above 106°F (41°C) 50% RH.

INSTALLATION (cont.)

Moving the Unit

Unlock all 4 casters and push the MovinCool unit, using the front or rear handles, to a flat, level surface and set the casters back to the LOCKED position.

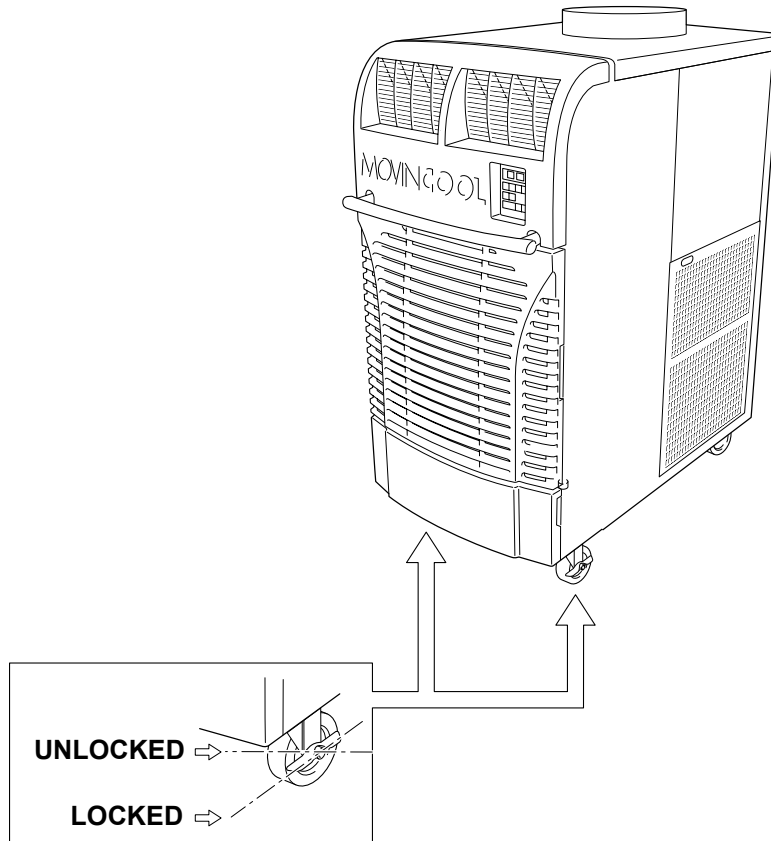

INSTALLATION (cont.)

Plugging in the Unit

1. Check the prong and surface of the power cord plug for dust/dirt. If dust and/or dirt are present, wipe off with a clean, dry cloth.
2. Check the power cord, plug and prong for damage or excess play. If any damage or excess play is found, contact your MovinCool reseller for repair.



WARNING:

1. **If the power cord or plug is damaged, repair should only be performed by qualified electrical personnel.**
2. **Do not connect/disconnect the power cord or attempt to operate buttons with wet hands. This could result in electrical shock.**



CAUTION:

The AC outlet (480 VAC 3 Phase, 60Hz) needs to be rated at 20A or higher. Do not share the outlet with any other instrument or equipment.

Note:

1. *Make sure the AC outlet is free of dirt, dust, oil, water or any other foreign matter.*
2. *The Office Pro 63 is equipped with an approved NEMA plug configuration (L16-20). The appropriate outlet must be used for this plug type.*

INSTALLATION (cont.)

Warning Signal Connection (Output Signal Terminal L+ and L-)

The controller is equipped with a warning signal output relay type (Form C, normal open dry contact) which can be used to monitor the failure condition.

Relay contactor (not connector) is closed when the following condition has occurred:

- a. Tank full
- b. Temperature sensor fails
- c. High pressure switch error

The relay output contactor is rated 2A at 30VDC or 2A at 30VAC (resistive load) and it is compatible with various warning devices such as alarm speaker, light indicators, etc.

Connecting Warning Signal From Controller

1. Remove service panel from the rear of the unit.
2. Squeeze the inner latches and push out the black cap from inside the panel.
3. Use recommended warning signal wire size from 16AWG to 26AWG for a solid wire, or 16AWG to 22AWG for a stranded wire with ring terminal for #6 stud size.
4. Connect warning device to terminal L+ and L- according to its polarities.

INSTALLATION (cont.)

Fire Alarm Control Panel Connection (Input Signal Terminal E+ and E-)

The controller is equipped with a normal open input signal, which can be connected directly from the fire alarm control panel. When receiving the signal from the fire alarm control panel, the unit turns off and does not turn back on until it has been RESET.

Connecting Fire Alarm Control Panel to Controller

1. Remove service panel from the rear of the unit.
2. Squeeze the inner latches and push out the black cap from inside the panel (see drawing of cap and inner latch shapes).
3. Use recommended warning signal wire size from 16AWG to 26AWG for a solid wire, or 16AWG to 22AWG for a stranded wire with ring terminal for #6 stud size.
4. Connect warning device to terminal E+ and E- according to its polarities.

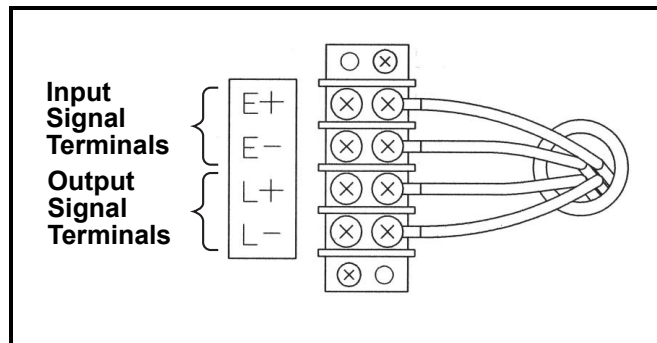
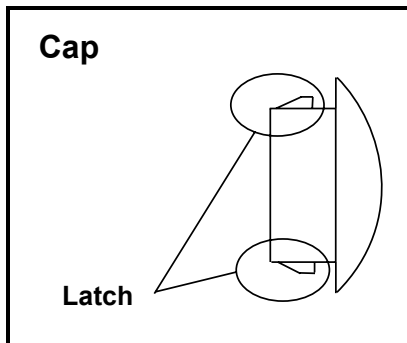

FEATURES

For all models:

1. A digital electronic control panel, which allows the user to control the unit's operation easily.
2. Dual fan speeds (either HIGH or LOW) in both COOL and FAN ONLY modes.
3. Digital LCD display with blue backlight that indicates:
 - a. Clock with day and time
 - b. Room temperature and set point temperature (either Fahrenheit or Celsius)
 - c. Fan speed status
 - d. Cool mode status
 - e. Program start time and stop time
 - f. Program run and stop
 - g. Status codes
 - h. Key locked option
4. The set point temperature can be adjusted between 65°F (18.3°C) and 90°F (32.2°C) by the SET TEMP buttons (Δ/∇).
5. Fire alarm control panel connection ready for automatic shut off.
6. Automatic shut off and warning signal output and alarm for temperature sensor failure, cooling failure.
7. A condensate drain "TANK FULL" indicator (LED) and display (LCD).
8. An automatic restart feature when the power is lost and regained.
9. A condensate pump with safety switch shut off.

OPERATION

Control Panel

Before operating the unit, it is important to familiarize yourself with the basic controls located on the control panel.

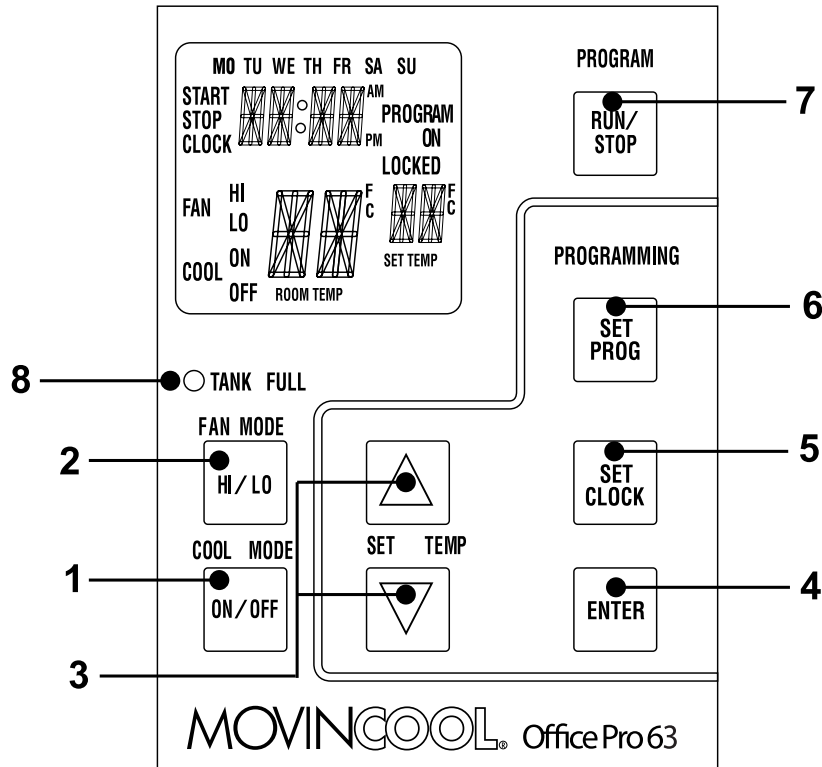

- 1. COOL Mode Button** Activates/deactivates the COOL mode/turns the unit off.
- 2. FAN Mode Button** Activates/deactivates the high, low, and off fan speed.
- 3. SET TEMP Buttons (Δ/∇)** Temperature scale illuminates to indicate the current LED temperatures being displayed are either in $^{\circ}\text{C}$ or $^{\circ}\text{F}$; also displays the clock when programming.
- 4. ENTER Button** Press to select set up value.
- 5. SET CLOCK Button** Press to set clock (day and time).
- 6. SET PROG Button** Press to set or view program.
- 7. RUN/STOP Button** Activates/deactivates program(s).
- 8. TANK FULL LED** Flashes when the drain tank is full.

OPERATION (cont.)

Control Panel (cont.)

LCD Indicators

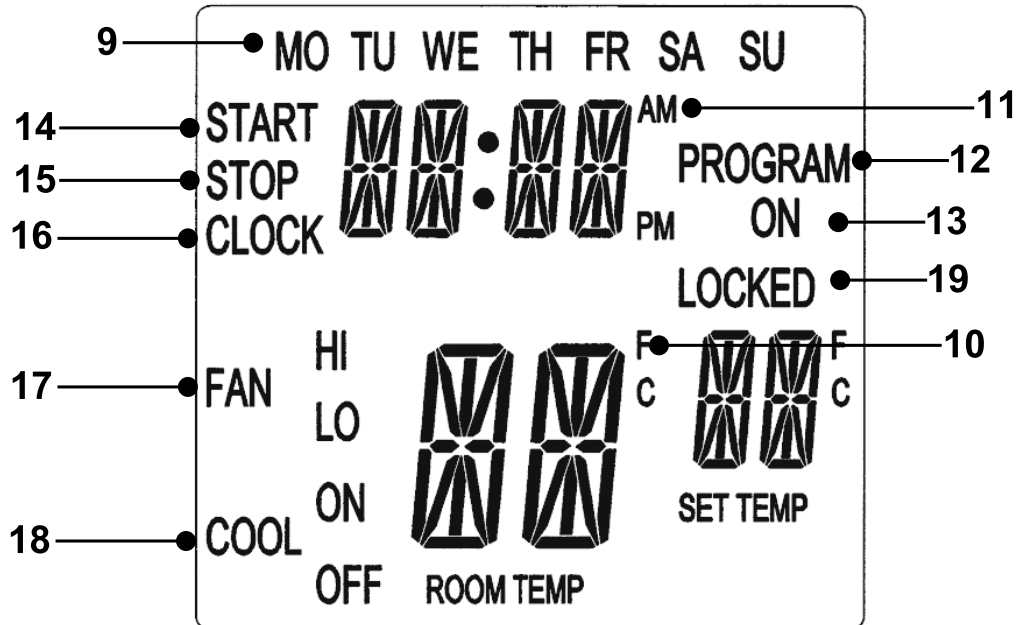

9. MO...SU

Illuminates to indicate selected day of the week.

10. °C or °F

Temperature displayed in either Fahrenheit or Celsius (see Note).

11. AM/PM

Illuminates to indicate AM or PM time of day.

12. PROGRAM

Blinking during program editing mode.

13. PROGRAM ON

Illuminates to indicate program is running.

14. START

Illuminates to indicate program start time.

15. STOP

Illuminates to indicate program stop time.

16. CLOCK

Illuminates to indicate clock status.

17. FAN HI/LO

Illuminates to indicate selected fan speed.

18. COOL ON/OFF

Illuminates to indicate cool on or off.

19. LOCKED

Illuminates to indicate key lock up.

Note: ROOM TEMP display range from 16°F to 109°F (-9°C to 42°C). In Fahrenheit only, when display values are greater than 99°F, it displays values of +0F (for 100°F), +1F (for 101°F) and +9F (for 109°F).

OPERATION (cont.)

Set Clock

Prior to operating the Office Pro 63 users should set the clock of the controller to the correct time as shown in the steps below.

1. Press and hold the SET CLOCK button for 3 seconds or until beep. (LCD indicates blinking “CLOCK” and blinking “day of the week”.)
2. Press SET TEMP buttons to select day of the week.
3. Press ENTER button to set hour.
4. Press SET TEMP buttons to select desired hour.
5. Press ENTER button to set minute.
6. Press SET TEMP buttons to select desired minute. Press SET CLOCK button to exit set clock mode.

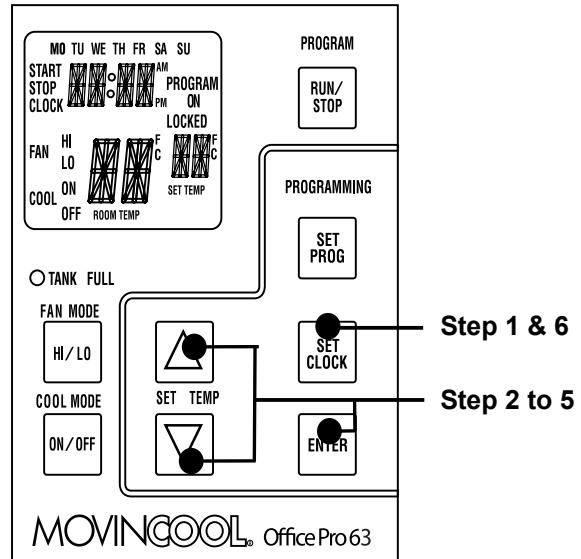

Note: User should check clock periodically to confirm clock accuracy.

Operating in COOL Mode

1. The unit can be operated in COOL mode by pressing the COOL ON/OFF button (LCD indicates “COOL ON”).
Note: In COOL mode the unit can only be turned off by pressing the COOL ON/OFF button again, not by pressing the fan buttons.
2. Change the fan speed by pressing the FAN HI/LO button.
3. Change the temperature set point by pressing the SET TEMP buttons (Δ/∇).

Note: When turning the unit on, the set point and fan speed are determined by the last operating mode. (This function does not apply to PROGRAM mode.)

OPERATION (cont.)

Operating in FAN ONLY Mode

1. The unit can also be operated in FAN ONLY mode by pressing FAN HI/LO button (LCD indicates “FAN HI/LO” and “COOL OFF”).
2. The unit can then be turned off by pressing the FAN HI/LO button until fan turns off (FAN ONLY mode speed sequences are HI→LO→OFF).

Changing from FAN ONLY Mode to COOL Mode

The COOL mode can be activated while the unit is operating in FAN ONLY mode. To do this, simply press the COOL ON/OFF button (LCD indicates “COOL ON”).

Note: The FAN ONLY mode does not operate after the COOL mode has been activated. After the COOL mode has been activated, the unit cannot be turned off by pressing the fan buttons. The COOL ON/OFF button must be pressed.

Keypad Lock

Keypad lock disables all buttons on the controller panel except keypad lock and unlock operations.

1. To lock, press and hold ENTER and SET CLOCK buttons simultaneously for 5 seconds.
2. To unlock, press and hold ENTER and SET CLOCK buttons simultaneously for 5 seconds again.

Note: When the unit detects operation failure, keypad is unlocked automatically and self-diagnostic code illuminates.

OPERATION (cont.)

How to Set a Program

SET START TIME

1. Press and hold the SET PROG button for 3 seconds or until beep.
2. Press SET TEMP buttons to select day of the week.
3. Press ENTER button.
4. Press SET TEMP buttons to select desired hour.
5. Press ENTER button.
6. Press SET TEMP buttons to select desired minute.
7. Press ENTER button.

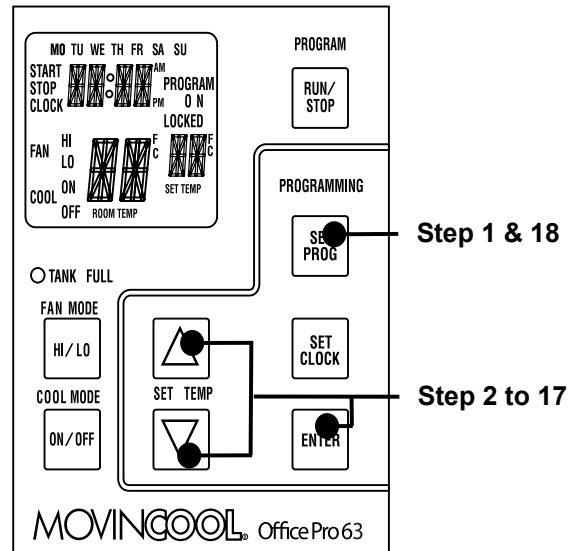

SET STOP TIME

8. Press SET TEMP buttons to select day of the week.
9. Press ENTER button.
10. Press SET TEMP buttons to select desired hour.
11. Press ENTER button.
12. Press SET TEMP buttons to select desired minute.
13. Press ENTER button.

SET FAN SPEED

14. Press SET TEMP buttons to select desired fan speed.
15. Press ENTER button.

SET SET-POINT TEMPERATURE

16. Press SET TEMP buttons to select desired temperature.
17. Press ENTER button.

EXIT PROGRAM EDITING MODE

18. Press SET PROG button to exit program editing mode.

EDIT MULTIPLE PROGRAMS

19. Repeat step 1. to 18. to set up multiple programs.

Note: Maximum 7 programming sequences

OPERATION (cont.)

How to View and Delete Program

1. Press and hold the SET PROG button for 3 seconds or until beep.
2. To view edited program - While pressing and holding the SET PROG button, press SET TEMP buttons (Δ/∇) to scroll the program sequence.
3. To delete a program - Press ENTER and SET PROG buttons once simultaneously.
4. To delete multiple program - Press and hold ENTER and SET PROG buttons simultaneously.

How to Run and Stop Program

1. Press RUN/STOP button to activate preset program (LCD indicates "PROGRAM ON"). During PROGRAM RUN mode, if you push RESET (press FAN HI/LO and COOL ON/OFF buttons simultaneously for 5 seconds), PROGRAM RUN mode is terminated. To resume PROGRAM RUN mode, you must push RUN/STOP button again.
2. Press RUN/STOP button to stop program.

Note:

1. *The unit returns to the previous mode if a program is turned off while it is running.*
2. *The LCD continues to indicate "PROGRAM ON" during program activating.*
3. *Program can be set during power on standby, during unit running, or during program running.*
4. *During programming, the unit returns to the previous mode if no activity occurs within approximately 3 minutes.*

OPERATION (cont.)

Operating Modes

Office Pro 63 operates in 2 modes, FAN ONLY and COOL. When in FAN ONLY mode, the unit circulates the surrounding air, Office Pro 63 is equipped with an automatic fan speed control when operating in FAN ONLY mode. When in COOL mode, the compressor is operated and cool air is circulated. Office Pro 63 is equipped with automatic condenser fan speed control depending on room temperature.

Office Pro 63 operates in FAN ONLY mode for approximately 120 seconds before the compressor engages.

(Time delay setting is around 120 seconds.)

1. Temperature Control

The room temperature thermistor allows the unit to switch automatically between COOL and FAN ONLY modes. This is dependent upon inlet air temperature versus set point temperature.

2. Fan Mode Control DIP Switch

The fan mode control DIP switch determines whether the fan continues to operate or stop when the compressor cycles off. (Set point temperature equals inlet air or room temperature.) The unit has been preset at the factory for continuous fan operation.

3. Temperature Scale Display DIP Switch

The temperature scale display DIP switch changes the temperature(s) that are displayed to either °C or °F. The unit has been preset from the factory to display the temperature(s) in °F.

Note: If you wish to change the fan mode operation (OPERATE to STOP), and/or the temperature scale display (°F to °C), contact your MovinCool reseller.

OPERATION (cont.)

Self-Diagnostic Codes

Self-diagnostic codes are displayed on the control board under the following conditions.

LCD Display Codes	Condition
	<p>When the drain tank switch shuts off the unit, LCD displays “TANK FL” and “TANK FULL” LED flashes. Once emptying the drain tank procedure is completed and ON/OFF has been pushed, unit returns to normal operation.</p>
	<p>When the drain pump malfunctions, the compressor shuts off, and the LCD displays “AS”. Once drain pump is fixed and unit has been RESET, the unit returns to normal operation. To RESET: Press FAN HI/LO and COOL ON/OFF buttons simultaneously for 5 seconds.</p>
	<p>When high pressure switch is activated, display shows “HP” if high pressure switch is activated 3 times in 24 hours, unit displays blinking “HP” and a buzzer turns on (see page 27). Unit returns to normal operation after problem is fixed and controller is RESET. To RESET: Press FAN HI/LO and COOL ON/OFF buttons simultaneously for 5 seconds.</p>
	<p>When room thermistor becomes open or shorted, display shows “OPEN RT” or “SHRT RT” and cool mode operation is off. Display and cool mode operation are returned to normal operation after room thermistor is fixed.</p>
	<p>When freeze thermistor becomes open or shorted, display shows “OPEN FT” or “SHRT FT” and cool mode operation is off. Display and cool mode operation are returned to normal operation after freeze thermistor is fixed.</p>
	<p>When the unit detects a signal from the fire alarm system, the display shows “ALRM” and a buzzer turns on. Check the fire alarm system and confirm that there is no signal input to the unit. The unit returns to the normal operation after the problem is fixed and the controller is RESET. To RESET: Press FAN HI/LO and COOL ON/OFF buttons simultaneously for 5 seconds.</p>

Contact your MovinCool reseller or a qualified technician if problem persists.

OPERATION (cont.)

Empty the Drain Tank (If equipped)

During COOL mode, condensate water accumulates in the drain tank. When the drain tank becomes full, the “TANK FULL” LED flashes and LCD displays “TANK FL”, and the alarm signal output is turned ON and the unit turns off automatically.

Note: If you want to empty the drain tank, while the unit is in operation, press the COOL ON/OFF button to turn the unit off.

OFFICE PRO 63 MODEL

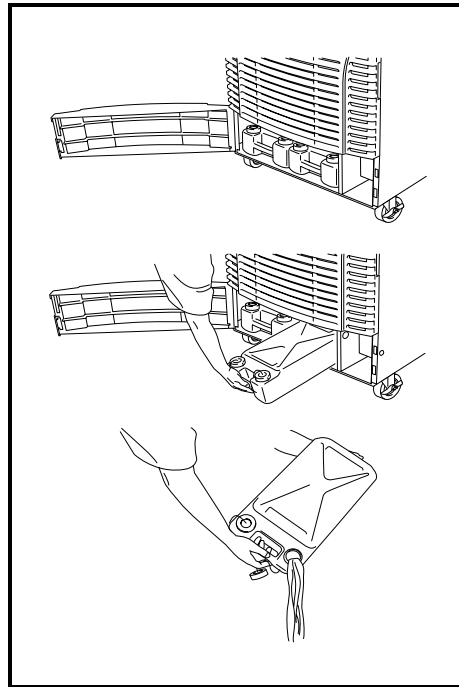

1. Open the drain tank door of Office Pro 63.
2. Pull the drain tank from the unit, display indicates “TANK” and alarm signal output stays ON.
3. Remove the cap and empty the drain tank.
4. Replace the cap and return the drain tank to the unit.
5. Close the front panel or drain tank door.
6. Press the COOL ON/OFF button to continue running the unit, display and alarm signal return to normal operation.

OPERATION (cont.)

Drain Pump

A drain pump is included for the Office Pro 63.

A drain pump provides a continuous operation and eliminates the need for a drain tank.

1. When the water collects to level (A) in the pump reservoir, the drain pump begins to operate and discharge the water. During drain pump operating period, the compressor cycles off.
2. When the water level drops below level (B), the drain pump stops and compressor restarts after delay time has expired.

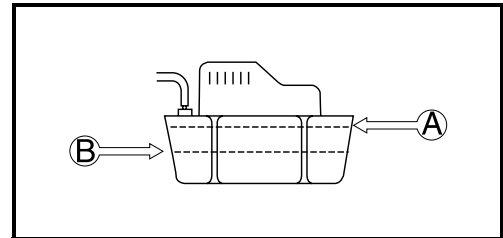

Note:

1. If for any reason the water level exceeds that of level (A) in the pump reservoir, an overflow drain switch stops the compressor operation.
2. If the fan mode control DIP switch (see page 20) has been set from the COOL to the STOP position, the Fan also turns off while the drain pump is discharging the water.

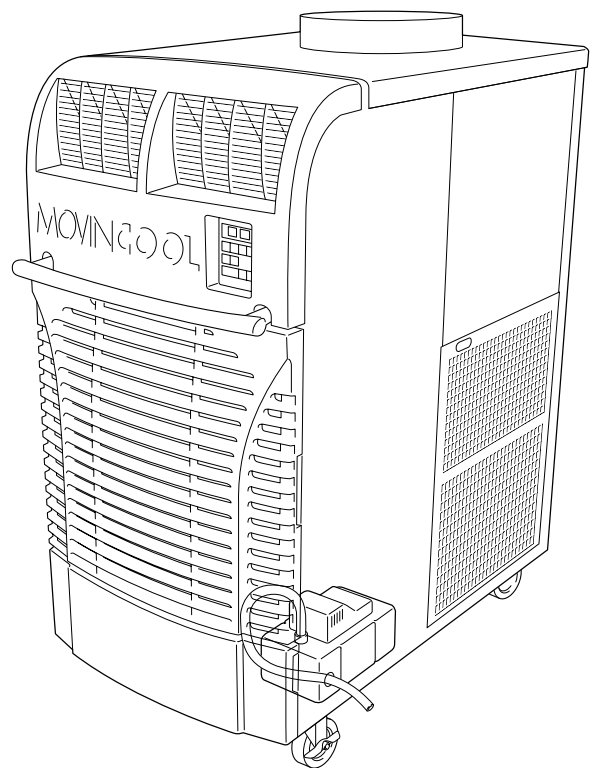

HOSE INSTALLATION

Note: The Office Pro 63 is supplied with a 20 foot (6m) hose.

Connect the 20 foot (6m) hose to the drain stem and feed it through the grommet on the right hand side of the unit.

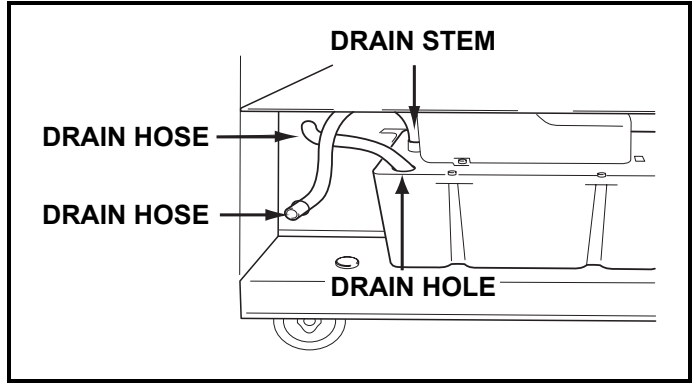
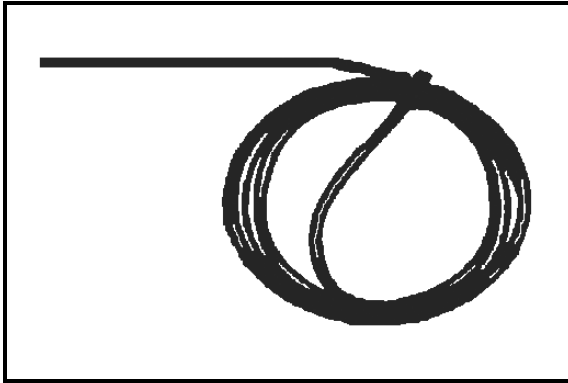

Note: The pump's maximum lift is 17 feet (5.2m) at rated voltage (460V). Please check the drainage performance after installation. It is important that the drainage line from the pump is free of kinks and is not pinched. Power fluctuation or low voltage could result in incorrect drainage.

To insure proper drainage, locate the highest vertical position, no more than 17 feet (5.2m), and run the drain hose on a downward slope at a minimum rate of 1/4 inch (6.25mm) per foot.

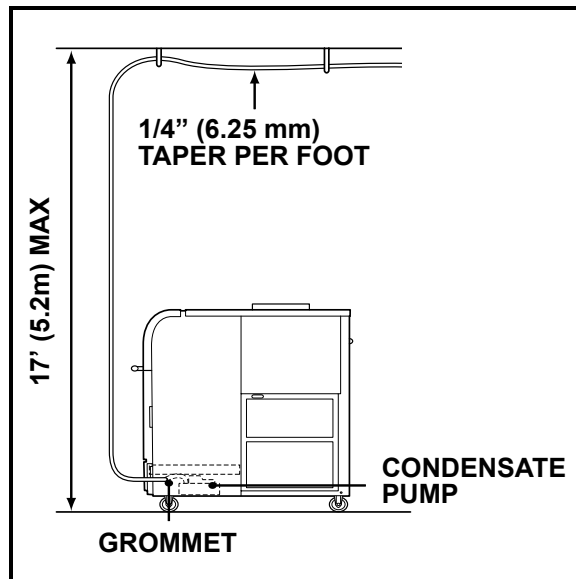

DAILY INSPECTION & MAINTENANCE

Empty the Drain Tank

To empty the drain tank, refer to instructions on page 22.

Clean the Air Filters

Clean the air filters once a week. If the unit is used in a dusty environment, more frequent cleaning may be required. A dirty air filter can reduce air output resulting in a decrease of the cooling capacity.

Filter Removal Method

1. Turn the unit off, by pressing the COOL ON/OFF button. If a program is running, you must first press the PROGRAM RUN button.
2. Remove the two air filters.

Note: To remove the filters from the Office Pro 63, open the front panel and side panel filter doors. On the side panel door, carefully remove the filter element from wire frame attachment points. On the front, unclip the wire frame and remove filter.

FRONT PANEL FILTER DOOR

SIDE PANEL FILTER DOOR

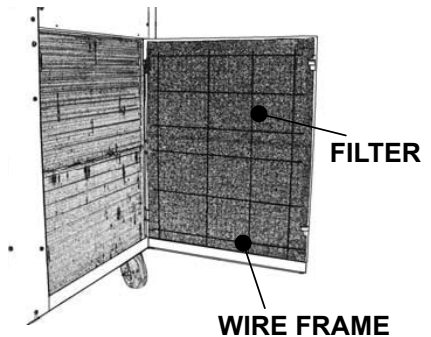
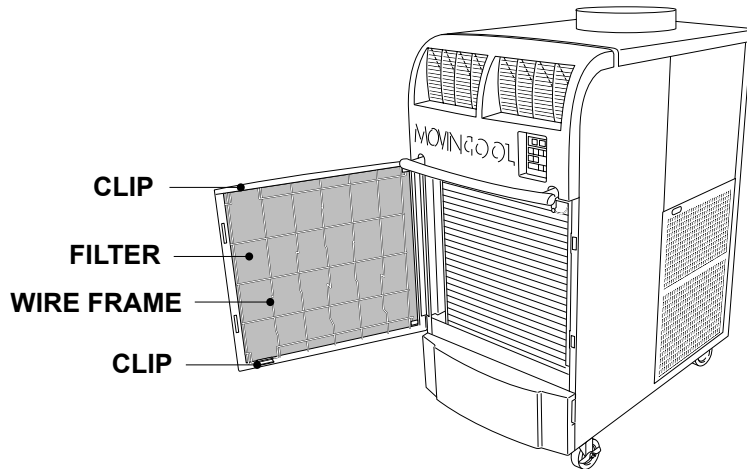

DAILY INSPECTION & MAINTENANCE (cont.)

Filter Cleaning Method

1. Remove dust from the element with a vacuum cleaner, or rinse in cold or lukewarm water. If the element is extremely dirty, wash with a neutral detergent.
2. After the element has been cleaned, rinse with clean running water, allow to dry, then reinstall.

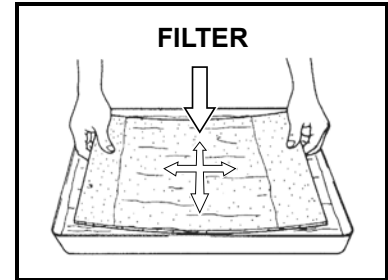

In-Season/Off-Season Inspection & Maintenance

In-Season

1. Check the prongs and surface of the power cord plug for dust and/or dirt. If dust and/or dirt are present, wipe off with a clean dry cloth.
2. Check the power cord, plug and prongs for damage or excess play. If any damage or excess play is found, contact your MovinCool reseller for repair.
3. Check the air filters and drain tank.
4. Clean the outside of the unit(s) with a damp cloth or mild nonabrasive cleaner.

Off-Season

1. Operate the unit in FAN ONLY mode for 8 hours.
Note: Operation is necessary to dry out the inside of the unit.
2. Disconnect the power cord from the AC outlet.
3. Check the prongs and surface of the power cord plug for dust and/or dirt. If dust and/or dirt are present, wipe off with a clean dry cloth.
4. Check the power cord, plug and prongs for damage or excess play. If any damage or excess play is found, contact your MovinCool reseller for repair.
5. Clean the air filters.
6. Empty all water from the drain tank.

TROUBLESHOOTING

Check the following items before calling your MovinCool reseller or a qualified technician.

CONDITION	POSSIBLE CAUSE	REMEDY
Unit does not operate.	1. Ground fault breaker trip or LCDI power cord trip.	Reset breaker or reset power cord.
	2. Drain tank is full. ("TANK FULL" LED flashes.)	Empty the drain tank.
	3. High pressure switch activated 10 times in 24 hours.	<ol style="list-style-type: none"> 1. Clean air filter. 2. Check inlet and outlet air to make sure that there are no objects preventing the air flow into or out from the unit. 3. Check environmental condition whether it is within operation range or not. 4. Reset controller To RESET: Press FAN HI/ LO and COOL ON/OFF buttons simultaneously for 5 seconds, controller returns to normal operation.
Insufficient cooling.	1. Dirty/Blocked air filters.	Clean air filter.
	2. Air inlet/outlet blocked.	Clean air inlet/outlet.
	3. Improper temperature setting.	Adjust temperature setting.

If conditions persist after the above actions have been taken, turn the unit off, disconnect the power and contact your MovinCool reseller or a qualified technician.



MOVINCOOL®

THE #1 SPOT COOLING SOLUTION

WARRANTY STATEMENT

DENSO PRODUCTS AND SERVICES AMERICAS, INC. ("DENSO") warrants its MOVINCOOL products only to the extent stated in its official written warranties. Unless otherwise specifically provided in writing by DENSO, DENSO warrants to the original end-user that the products shall be free of defects in materials or workmanship and will function in accordance with DENSO's published specifications under ordinary intended use and service for a period listed below beginning from the date of purchase on the invoice to the end-user:

Office Pro 63 Warranty: 3 Years with warranty registration OR 1 Year for unregistered units.

DENSO shall, at its sole discretion, repair or replace any defective product covered by this warranty. Such remedy shall be end-user's sole remedy with respect to any particular defect in the products.

This warranty does not cover defects or malfunctions which result from causes beyond DENSO's control, including, without limitation, (i) unusual physical or electrical stress; (ii) accident, neglect, abuse, misuse or other abnormal use; (iii) failure to perform routine maintenance in accordance with DENSO's recommended procedures; (iv) normal wear and tear; (v) repairs or attempted repairs by an unauthorized person; (vi) modifications or alterations to the products; (vii) use with parts or devices not supplied or approved by DENSO; (viii) improper installation or service; (ix) shipping damage to any units or spare parts during shipping. This includes and is not limited to compressors, evaporators and condenser coils. This warranty shall extend only to the original end-user and shall be void if any labels or other identifying marks permanently affixed to products when shipped by DENSO are removed, altered, defaced or obliterated.

TO THE EXTENT PERMITTED BY LAW, THIS WARRANTY, AS LIMITED HEREIN, SHALL BE IN LIEU OF AND EXCLUSIVE OF ALL OTHER WARRANTIES, EITHER EXPRESSED OR IMPLIED, ON THE PART OF DENSO PRODUCTS AND SERVICES AMERICAS, INC., OR DENSO CORPORATION, WHETHER ARISING FROM LAW, COURSE OF DEALING, USAGE OF TRADE, OR OTHERWISE, INCLUDING WITHOUT LIMITATION ANY IMPLIED WARRANTY OF MERCHANTABILITY OR FITNESS OF A PARTICULAR PURPOSE OR ANY LIABILITY FOR COMMERCIAL LOSSES BASED UPON NEGLIGENCE OR MANUFACTURER'S STRICT LIABILITY. EXCEPT AS EXPRESSLY PROVIDED HEREIN, NEITHER DENSO PRODUCTS AND SERVICES AMERICAS, INC., NOR DENSO CORPORATION WILL, IN ANY EVENT, BE LIABLE FOR LOST PROFITS, COSTS OF PROCESSING, INJURY, GOODWILL, OR ANY OTHER CONSEQUENTIAL DAMAGES OF ANY KIND ARISING FROM BREACH OF THIS WARRANTY.

DENSO PRODUCTS AND SERVICES AMERICAS, INC. reserves the right to make changes without prior notice. MovinCool®, Office Pro® and SpotCool® are registered trademarks of DENSO Corporation.

PURCHASE DATE: _____

SERIAL NUMBER: _____

DENSO

DENSO PRODUCTS AND SERVICES AMERICAS, INC.

Long Beach, CA 90810

www.movincool.com

P/N: 484007-3601EN

Second Issue: April 2013