

# Use & Care Guide

## Vent Hood

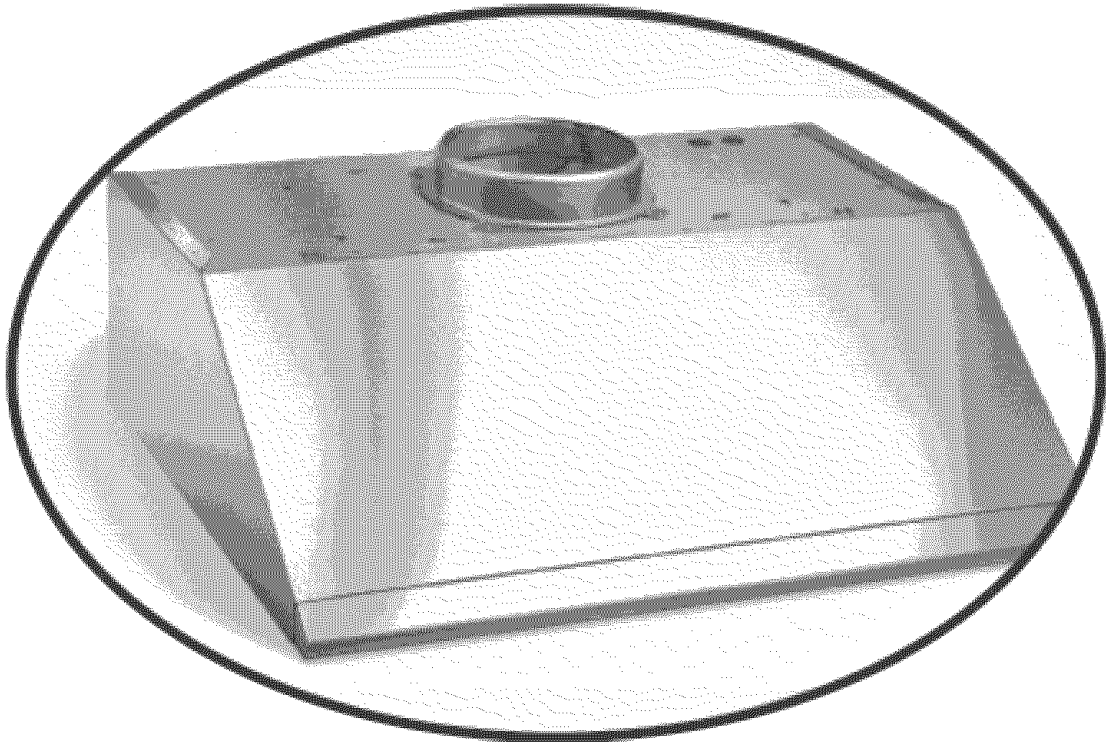

 **Electrolux**

E30WV60EPS

E36WV60EPS

E48WV12EPS

E308WV60ES

E368WV60ES

E488WV120S

5995438586

# 2 Finding Information

---

## PLEASE READ AND SAVE THIS GUIDE

---

Attach your sales receipt to this page for future reference.

Thank you for choosing **Electrolux**, the new premium brand in home appliances. This *Use & Care Guide* is part of our commitment to customer satisfaction and product quality throughout the service life of your new hood.

We view your purchase as the beginning of a relationship. To ensure our ability to continue serving you, please use this page to record key product information.

### IMPORTANT

**PLEASE READ** all instructions completely before attempting to install or operate the unit.

Once you have your unit installed, we suggest you keep this manual in a safe place for future reference. Should any problems occur, refer to the **Troubleshooting** section of this manual. This information will help you quickly identify a problem and get it remedied. In the event you require assistance, please contact the dealer where you purchased your unit.

## MAKE A RECORD FOR QUICK REFERENCE

---

Whenever you call to request information or service, you will need to know your model number and serial number. You can find this information on the serial plate located on the inside wall of your unit and on the product registration card.

## PRODUCT REGISTRATION INFORMATION

The package containing this manual also includes your product registration information. Warranty coverage begins at the time your Electrolux vent hood was purchased.

If you received a damaged product, immediately contact your dealer or builder. Do not install or use a damaged appliance.

### NOTE

Registering your product with Electrolux enhances our ability to serve you. You can register online (at the Internet address below) or by dropping your Product Registration Card in the mail. Complete and mail the Product Registration Card as soon as possible to validate the registration date.

Please record the purchase date of your Electrolux unit and your dealer's name, address and telephone number.

\_\_\_\_\_

Purchase Date

\_\_\_\_\_

Electrolux Model Number

\_\_\_\_\_

Electrolux Serial Number

\_\_\_\_\_

Dealer Name

\_\_\_\_\_

Dealer Address

\_\_\_\_\_

Dealer Telephone

Keep this manual and the sales receipt together in a safe place for further reference.

## QUESTIONS?

For toll-free telephone support in the U.S. and Canada:  
**1-877- 4ELECTROLUX (1-877-435-3287)**

For online support and Internet product information:  
**[www.electroluxusa.com](http://www.electroluxusa.com)**

## TABLE OF CONTENTS

---

<b>Finding Information</b> .....	2
Please Read And Save This Guide .....	2
Make A Record For Quick Reference .....	2
Questions .....	3
Table Of Contents .....	4
<b>Safety</b> .....	5
Important Safety Instructions .....	5
General Precautions .....	6
<b>Getting Started</b> .....	8
Operating Your Hood .....	8
<b>Care and Cleaning</b> .....	10
Cleaning Your Hood .....	10
<b>Maintenance</b> .....	11
Changing the Bulb .....	11
<b>Troubleshooting</b> .....	12
If Service is Required .....	12
Troubleshooting Guide .....	13
<b>Warranty Information</b> .....	14

## IMPORTANT SAFETY INSTRUCTIONS

---

### Safety Precautions

Do not attempt to install or operate your unit until you have read the safety precautions in this manual. Safety items throughout this manual are labeled with a Warning or Caution based on the risk type.

### Definitions

 This is the safety alert symbol. It is used to alert you to potential personal injury hazards. Obey all safety messages that follow this symbol to avoid possible injury or death.

#### **WARNING**

**WARNING** indicates a potentially hazardous situation which, if not avoided, could result in death or serious injury.

#### **CAUTION**

**CAUTION** indicates a potentially hazardous situation which, if not avoided, may result in minor or moderate injury.

#### **CAUTION**

**CAUTION** used without the safety alert symbol indicates a potentially hazardous situation which, if not avoided, may result in property damage.

#### **IMPORTANT**

Indicates installation, operation or maintenance information which is important but not hazard related.

# 6 Safety

## General Precautions

### **WARNING**

- To reduce the risk of a range top grease fire:
  - a) Never leave surface units unattended at high settings. Boilovers cause smoking and greasy spillovers that may ignite. Heat oils slowly on low or medium settings.
  - b) Always turn hood ON when cooking at high heat or when flambing food (i.e. Crepes Suzette, Cherries Jubilee, Peppercorn Beef Flambe').
  - c) Clean ventilating fans frequently. Grease should not be allowed to accumulate on fan or filter.
  - d) Use proper pan size. Always use cookware appropriate for the size of the surface element.
- To reduce the risk of injury to persons in the event of a range top grease fire, observe the following:
  - a) **SMOTHER FLAMES** with a close-fitting lid, cookie sheet, or metal tray, then turn off the burner. **BE CAREFUL TO PREVENT BURNS.** If the flames do not go out immediately, **EVACUATE AND CALL THE FIRE DEPARTMENT.**
  - b) **NEVER PICK UP A FLAMING PAN** - You may be burned.
  - c) **DO NOT USE WATER**, including wet dishcloths or towels - a violent steam explosion will result.
  - d) Use an extinguisher **ONLY** if:
    - 1) You know you have a Class ABC extinguisher, and you already know how to operate it.
    - 2) The fire is small and contained in the area where it started.
    - 3) The fire department is being called.
    - 4) You can fight the fire with your back to an exit.
- To reduce the risk of fire, electric shock, or injury to persons, observe the following:
  - a) Use this unit only in the manner intended by the manufacturer. If you have questions, contact the manufacturer.
- Unplug or disconnect this appliance from the power supply before servicing.

### **CAUTION**

For general ventilating use only. Do not use to exhaust hazardous or explosive materials and vapors.

## CAUTION

- Begin by ensuring proper installation and grounding of the hood by a qualified installer. Have the installer show you where the fuse or junction box is located so that you know how and where to turn off power.
- Always be certain that nothing will interfere with the vent intake.
- Use the vent system for its intended purpose only as outlined in this manual.
- Clean the filters and all grease-laden surfaces often to prevent grease fires and maintain performance.
- If the cooktop and hood are near a window, use an appropriate window treatment. Avoid long drapes or other window coverings that could blow over the cooktop and hood, resulting in a fire hazard.
- Always run the blower whenever a cooktop is operating.
- Never operate the hood without the filters in place.
- Do not operate the blower if a flame or flare-up develops. In the event of a flame, immediately turn off the blower. Smother the flame or use an appropriate class dry chemical or foam-type fire extinguisher.
- Never leave the appliance unattended when using high heat settings. Boil-overs and greasy spills may smoke and/or ignite.
- Do not leave children alone or unattended in the area where the cooktop and vent are in use. Never allow children to sit or stand on an appliance. Do not let children play with a cooktop or vent.
- Do not repair or replace any part of the vent system unless specifically recommended in literature accompanying this appliance. All service should be referred to a qualified technician.
- Do not use water on grease fires. A violent steam explosion may result. Also, avoid using wet potholders, sponges or clothes, as steam burn may occur.

## CAUTION

Do not store items of interest to children above or at the back of the cooktop or vent, as they could climb on the appliance to reach items and be injured.

# 8 Getting Started

---

## OPERATING YOUR HOOD

---

### IMPORTANT

Do not operate the vent system without the filters in place or with dirty, grease-laden filters.

The hood has two knobs that control the function of the hood's halogen lights and exhaust blower.

Turning the knobs clockwise will turn on the lights and the blower. The blower has a variable speed range between settings.

### Operating Tips:

- 1 Activate the blower a few minutes before starting to cook to establish an airflow pattern in the room.
- 2 Adjust the fan speed according to the volume and weight of the cooking exhaust.
- 3 Always activate the blower whenever using the cooking appliance.
- 4 Eliminate air currents in the hood vicinity by shutting nearby windows and doors, turning off ceiling fans and closing adjacent heating and air conditioning outlets.
- 5 Place your largest pans, skillets and stock pots on the rear burners whenever possible.

## ENERGY SAVING TIPS

---

- 1 Do not operate the blower at a speed that is higher than necessary to remove the cooking exhaust. Running at excessive speeds removes more air from the inside of the house that must be replaced by outside air. This may be especially costly when the housing air conditioning or heating system is in operation.
- 2 Clean filters and grease-laden surfaces often to improve efficiency.
- 3 Turn off the blower as soon as all cooking smoke and odors have been eliminated.
- 4 Always use lids on cookware to retain heat and moisture.
- 5 Minimize the amount of liquid used to cook food.
- 6 Select cookware of the proper size, material and construction for the cooking task being performed.

# 10 Care and Cleaning

---

## CLEANING YOUR HOOD

---

Proper cleaning is necessary to maintain vent performance and appearance, while also ensuring safe operation. The frequency of cleaning should be adjusted according to the type and amount of cooking. Best results will be achieved by cleaning soiled components as soon as possible.

Filters must be cleaned regularly. Remove one filter at a time, grasp the filter handle and gently push back and pull the front down.

The filters may be cleaned by hand washing in hot water with a mild detergent solution or by placing them in an automatic dishwasher. Dry the filters completely before using them again.

Stainless steel should be cleaned with a solution of mild detergent and warm water. Rinse and dry with a soft lint-free cloth.

### **CAUTION**

**If commercially available stainless steel cleaners are used, it is important to read the labels for chlorine compounds. Chlorine is a corrosive substance. If these compounds are present, rinse thoroughly and dry with a soft lint-free cloth.**

Follow manufacturer's instructions for application of polish.

Always wipe stainless steel surfaces with the grain. Never wipe across the grain.

After cleaning, reinstall the filters carefully.

## CHANGING THE BULB

---

The suction cup, part number 5304448673, supplied with the hood, is designed to assist in the removal and replacement of the halogen light bulbs, should they burn out. To remove a bulb, simply press the suction cup onto the face of the bulb and unscrew in a counter-clockwise direction (as you are facing the bulb). To install the new bulb, start the new bulb in the socket in a clockwise direction by turning a few times by hand, then attach the suction cup to the face of the bulb and complete the installation. Keep the suction cup in a safe place for future maintenance.

For replacement lamps, contact Electrolux at 1-877-435-3287 and order part number 5304448674.

### **IMPORTANT**

No maintenance, other than the CARE AND CLEANING INSTRUCTIONS identified in this Use & Care Manual, should be attempted by the owner/operator.

All other maintenance and service must be performed by a qualified appliance technician.

# 12 Troubleshooting

---

## IF SERVICE IS REQUIRED

---

First, review the recommended checks listed in the **Troubleshooting Guide**. Then, be certain that the appliance has been installed properly and is being operated correctly. Familiarize yourself with the warranty terms and conditions listed in the **Warranty** section.

If the above checks have been completed and the problem has not yet been remedied, contact the dealer where you purchased the unit. State the Model and Serial number and explain the problem. The Model and Serial number plate is located inside the unit at upper right hand corner.

If you do not know the name of the selling dealer or local service company, you can check online at [www.electroluxusa.com](http://www.electroluxusa.com).

## TROUBLESHOOTING GUIDE

---

### IMPORTANT

Unnecessary service calls may be expensive, frustrating and time consuming. Before you call for service, please review the potential problems, possible causes and remedies shown in the table below.

<i>Troubleshooting - What to check when problems occur</i>		
<b>Problem</b>	<b>Possible Cause</b>	<b>Remedy</b>
Nothing works.	Vent power supply interrupted or not energized.	Have electrician check power supply, including house circuit breaker and fuses.
Lights do not turn on.	A loose or burned out light.	Check the light.

# 14 Warranty Information

## **HOOD WARRANTY** *Your hood is protected by this warranty*

	WARRANTY PERIOD	THROUGH OUR AUTHORIZED SERVICERS, WE WILL:	THE CONSUMER WILL BE RESPONSIBLE FOR:
<b>FULL ONE-YEAR WARRANTY</b>	One year from original purchase date.	Pay all costs for repairing or replacing any parts of this product which prove to be defective in materials or workmanship.	Costs of service calls that are listed under <b>NORMAL RESPONSIBILITIES OF THE CONSUMER.*</b>
<b>LIMITED WARRANTY (Applicable to the State of Alaska)</b>	Time periods listed above.	All of the provisions of the full warranties above and the exclusions listed below apply.	Costs of the technician's travel to the home and any costs for pick up and delivery of the appliance required because of service.

In the U.S.A., your appliance is warranted by Electrolux Home Products, Inc. We authorize no person to change or add to any of our obligations under this warranty. Our obligations for service and parts under this warranty must be performed by us or an authorized Electrolux Home Products, Inc. servicer. In Canada, your appliance is warranted by Electrolux Canada Corp.

### \*NORMAL RESPONSIBILITIES OF THE CUSTOMER

**This warranty applies only to products in ordinary household use, and the consumer is responsible for the items listed below:**

1. Proper use of the appliance in accordance with instructions provided with the product.
2. Proper installation by an authorized servicer in accordance with instructions provided with the appliance and in accordance with all local plumbing, electrical and/or gas codes.
3. Proper connection to a grounded power supply of sufficient voltage, replacement of blown fuses, repair of loose connections or defects in house wiring.
4. Expenses for making the appliance accessible for servicing, such as removal of trim, cupboards, shelves, etc., which are not a part of the appliance when it was shipped from the factory.
5. Damages to finish after installation.
6. Replacement of light bulbs and/or fluorescent tubes (on models with these features).

### EXCLUSIONS

**This warranty does not cover the following:**

1. CONSEQUENTIAL OR INCIDENTAL DAMAGES SUCH AS PROPERTY DAMAGE AND INCIDENTAL EXPENSES RESULTING FROM ANY BREACH OF THIS WRITTEN OR ANY IMPLIED WARRANTY.  
*Note: Some states do not allow the exclusion or limitation of incidental or consequential damages, so this limitation or exclusion may not apply to you.*
2. Service calls which do not involve malfunction or defects in workmanship or material, or for appliances not in ordinary household use. The consumer shall pay for such service calls.
3. Damages caused by services performed by servicers other than Electrolux Home Products, Inc., Electrolux Canada Corp., or its authorized servicers; use of parts other than genuine Electrolux Home Products parts; obtained from persons other than such servicers; or external causes such as abuse, misuse, inadequate power supply or acts of God.
4. Products with original serial numbers that have been removed or altered and cannot be readily determined.

### IF YOU NEED SERVICE

Keep your bill of sale, delivery slip, or some other appropriate payment record. The date on the bill establishes the warranty period should service be required. If service is performed, it is in your best interest to obtain and keep all receipts. This written warranty gives you specific legal rights. You may also have other rights that vary from state to state. Service under this warranty must be obtained by contacting Electrolux Home Products, Inc. or Electrolux Canada Corp.

This warranty only applies in the 50 States of the U.S.A. and Puerto Rico, and Canada. Product features or specifications as described or illustrated are subject to change without notice. All warranties are made by Electrolux Home Products, Inc. In Canada, your appliance is warranted by Electrolux Canada Corp.

**USA**  
**1-877-4ELECTROLUX**  
 Electrolux Home Products, Inc.  
 P.O. Box 212378  
 Augusta, GA 30917

**Canada**  
**1-866-294-9911**  
 Electrolux Canada Corp.  
 6150 McLaughlin Road  
 Mississauga, Ontario  
 L5R 4C2