

Spec-Bar® Corner/Angle Workboards

INSTALLATION INSTRUCTIONS

CAUTION

INSPECT CONTENTS IMMEDIATELY AND FILE CLAIM WITH DELIVERING CARRIER FOR ANY DAMAGE. **SAVE YOUR BOX AND ALL PACKING MATERIALS.** YOU ARE RESPONSIBLE FOR DAMAGE TO YOUR UNIT IF RETURNED IMPROPERLY PACKED.

Parts List

qty	part #	description
1 ... *	workboard
12 ...	300794 ...	#8 x 1/2 drive screws

* Part number varies per order.

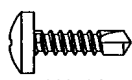

#300794
(actual size)

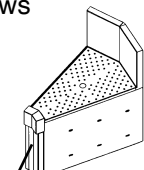

inner angle
workboard

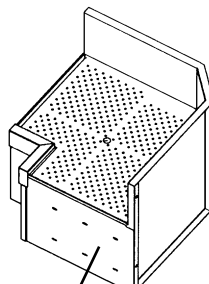

inner corner
workboard

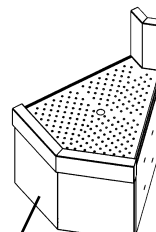

outer angle
workboard

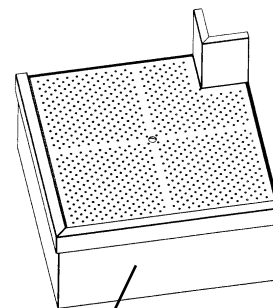

outer corner
workboard

Step 1 - Align corner/angle workboard with adjacent unit.

- Line up both units so that the backsplashes and fronts are flush with each other.
- If available, use a “C”-clamp to hold the units together temporarily.

Step 2 - Attach corner/angle workboard to adjoining unit.

- Using a drill, drive the self-tapping screws through the predrilled holes of the workboard and into the side panel of the adjoining unit.
- Remove the “C”-clamp, if one has been applied.

Please note: Be sure to use all of the holes.

Note: Angle Workboards might not allow the use of a drill. Holes need to be predrilled into adjoining unit. In place of screws provided, 1”-long hex-head bolts and nuts (sold separately) are required.

- Repeat **Step 1**.
- From underneath the angle workboard, mark hole locations with a marker.
- Set aside angle workboard.
- Drill 1/8”-diameter holes into the adjoining unit.
- Line up angle workboard to adjoining unit, again using a “C”-clamp if necessary.
- From underneath the adjoining unit, run bolt through each new hole, through each predrilled hole of the angle workboard, and fasten with nut. Repeat on all remaining holes. Tighten all hardware.
- Remove “C”-clamp, if one had been used.

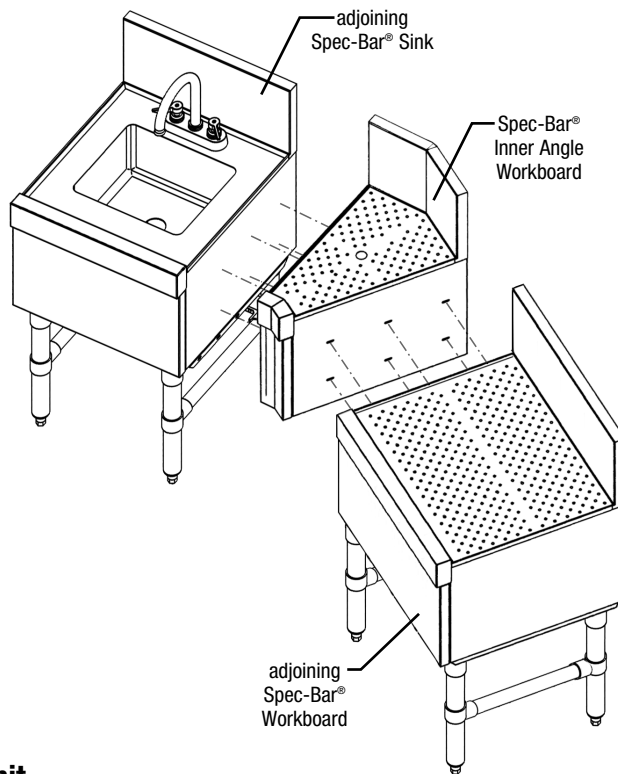

Step 3 - Attach corner/angle workboard to second adjacent unit.

- Repeat **Steps 1 & 2**.

(End) Installation is complete.

EG10064 Revised 09/23