

BEVERAGE CENTER
Owner's Manual.....1 - 8

MODEL • MODÈLE • MODELO
DBC122KD1BSS





Important Safety Information

READ AND FOLLOW ALL SAFETY INSTRUCTIONS

SAFETY REQUIREMENTS

To reduce the risk of fire, electrical shock or injury when using the appliance, follow these basic precautions.

DANGER: Risk of fire or explosion. Flammable refrigerant used. Do not puncture refrigerant tubing.

- Do not use mechanical devices to defrost refrigerator.
- Ensure that servicing is done by factory authorized service personnel, to minimize product damage or safety issues.
- Children aged from 3 to 8 years are allowed to load and unload refrigerating appliances.
- Cleaning and user maintenance shall not be made by children without supervision.
- Regularly clean surfaces that can come in contact with bottles and accessible drainage systems.
- Consult repair manual or owner's guide before attempting to service this product. All safety precautions must be followed.
- Dispose of properly in accordance with federal or local regulations.
- Follow handling instructions carefully.

WARNING: Keep ventilation openings, in the appliance enclosure or in the built-in structure, clear of obstruction.

WARNING: Do not use mechanical devices or other means to accelerate the defrosting process.

WARNING: Do not damage the refrigerant circuit.

WARNING: Do not use electrical appliances inside the food storage compartments of the appliance.

CAUTION: Children should be supervised to ensure that they do not play with the appliance.

DANGER: Risk of child entrapment. Before throwing away an old appliance:

- Remove the door or lid.
- Leave shelves in place so that children may not easily climb inside.

SAFETY REQUIREMENTS

This appliance is intended to be used in household and similar applications such as:

- Staff kitchen areas in shops, offices and other working environments;
- Farm houses and by clients in hotels, motels and other residential type environments;
- Bed and breakfast type environments;
- Catering and similar non-retail applications.

This appliance can be used by children aged from 8 years and above and persons whose physical, sensory or mental capabilities may be different or reduced, or who lack experience or knowledge, unless such persons receive supervision or training to operate the appliance by a person responsible for their safety.

Opening the door for long periods can cause a significant increase of the temperature inside the appliance.

To prevent damaging the door gasket ensure that the door is all the way open before removing a shelf.

This appliance must be positioned so that the plug is accessible. Do not move the cabinet while it is loaded with wine as this can warp the cabinet. Do not touch the compressor as it can be hot.

Do not store explosive substances such as aerosol cans with a flammable propellant in this appliance.

Never clean appliance parts with flammable fluids. The fumes can create a fire hazard or explosion.

Do not store or use gasoline or any other flammable vapors and liquids in the vicinity of this or any other appliance. The fumes can create a fire hazard or explosion.

If the refrigerant is R600a, flammable and explosive articles should not be put in or near the cabinet to avoid fire or explosion.



SAVE THESE INSTRUCTIONS!



Important Safety Information

READ AND FOLLOW ALL SAFETY INSTRUCTIONS

GROUNDING INSTRUCTIONS

This appliance must be grounded. Grounding reduces the risk of electrical shock by providing an escape wire for the electrical current.

This appliance has a cord that has a grounding wire with a 3-prong plug. The power cord must be plugged into an outlet that is properly grounded. If the outlet is a 2-prong wall outlet, it must be replaced with a properly grounded 3-prong wall outlet. The serial rating plate indicates the voltage and frequency the appliance is designed for.

WARNING - Improper use of the grounding plug can result in a risk of electric shock. Consult a qualified electrician or service agent if the grounding instructions are not completely understood, or if doubt exists as to whether the appliance is properly grounded.

Do not connect your appliance to extension cords or together with another appliance in the same wall outlet. Do not splice the power cord. Do not under any circumstances cut or remove the third ground prong from the power cord. Do not use extension cords or ungrounded (two prongs) adapters.

If the power supply cord is damaged, it must be replaced by the manufacturer, its service agent or similar qualified person in order to avoid hazard.

LOCATION

Remove interior and exterior packaging prior to installation. Wipe the outside of the appliance with a soft, dry cloth and the inside with a lukewarm wet cloth.

Place the appliance on a floor that is strong enough to support it when it is fully loaded.

Do not place the appliance in direct sunlight or near sources of heat, such as a stove or heater, as this can increase electrical consumption. Extreme cold ambient temperatures may also cause the appliance to perform improperly.

Do not use the appliance near water, for example in a wet basement or near a sink.

This appliance is intended for household use only. It is not designed for outside installation, including anywhere that is not temperature controlled (garages, porches, vehicles, etc.).

Before connecting the appliance to a power source, let it stand upright for approximately 6 hours. This will reduce the possibility of a malfunction in the cooling system from handling during transportation.

This appliance is 49.3 cm wide by 83 cm high by 61.5 cm deep.

This appliance is intended for free-standing installation only and is not intended to be built into a cabinet or counter. Building in this appliance can cause it to malfunction.

SAVE THESE INSTRUCTIONS!

OPERATING INSTRUCTIONS

FEATURES

1. **Control Panel**
2. **Magnetic Door Gaskets:** Tight fitting seals retain all the cooling power and humidity levels.
3. **Glass Shelves**
4. **Leveling leg**
5. **Interior Light:** (not pictured) Illuminates the compartment.

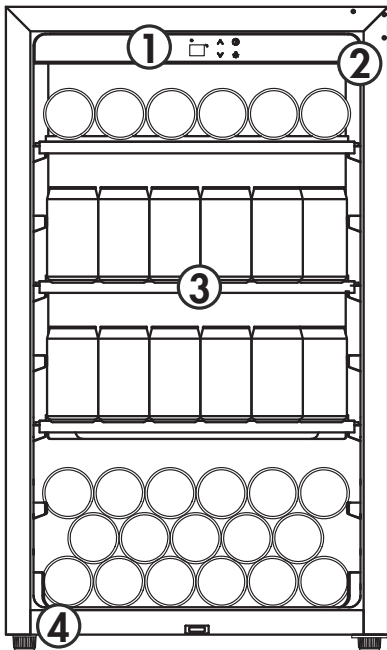

LEVELING INSTRUCTIONS

There is an adjustable leg on the bottom of the appliance that can be turned up or down to ensure that the appliance is level.

1. Turn the leveling leg counter-clockwise as far as it will go, until the top of the foot is touching the bottom of the cabinet.
2. Slowly turn the leveling leg clockwise until the appliance is level.

STOCKING INSTRUCTIONS

This beverage center has a maximum capacity of 122, 355 ml cans.

The first shelf will hold 18 cans.

The second and third shelves will hold 35 cans each.

The bottom section will hold 34 cans when stocked as pictured below.

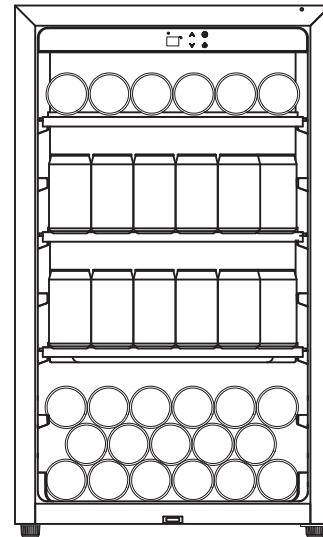

SHELF INSTRUCTIONS

To remove a shelf from its locked position, tilt the shelf as shown and then pull outward.

To reinstall the shelf, ensure it is resting securely on the support brackets and push inward until it locks into place.

Note: The bottom shelves in both compartments are not secured in place. Do not attempt to pull on these shelves when they are stocked with bottles or cans.

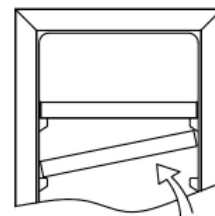

OPERATING INSTRUCTIONS

CONTROL PANEL

1. **Power indicator light:** Illuminates to signify that the compressor is in operation.
2. **Display:** Shows the set temperature. Press and hold the up or down button for 3 seconds to display the actual temperature inside the cabinet. After 5 seconds the display will resume normal operation.
3. **Up and Down Buttons:** Used to adjust the temperature setting in 1° increments.
4. **Power button:** Press this button to turn the appliance on. Press and hold this button for 3 seconds to turn the appliance off.
5. **Light button**



INTERIOR LIGHT

The interior light will default to turning on and off when the door is opened or closed.

Press and hold the light button for 5 seconds until the display shows "LP" to set the light to continuous illumination. After 4 seconds the display will return to normal operation and the light will remain on until manually turned off.

To resume normal light function, press and hold the light button for 5 seconds until the display show "LF". After 4 seconds the display will return to normal operation and the light will be set to turn on and off when the door is opened and closed.

FUNCTION INSTRUCTION

The default temperature setting is 6°C.

The temperature can be set as low as 2°C or as high as 12°C.

Actual temperature inside the appliance can vary based on ambient temperature, how often the door is opened and how many warm bottles have recently been added to the appliance.

Temperature Memory: If the appliance loses power, the control panel will remember the set temperature. Once power is restored, the appliance will return to normal functioning automatically.

Temperature Alarm: If the inner cabinet temperature is higher than 23°C for one hour, the error code "HI" will show on the display panel and an alarm will sound.

If the inner cabinet temperature is lower than -2°C the error code "LO" will show on the display panel and an alarm will sound.

Door Ajar Alarm: If the door is not closed completely for 5 minutes, an alarm will sound. Close the door to silence the alarm.

If the door is closed and the alarm continues to sound, check that the actuator at the bottom of the door is making contact with the switch on the appliance.

Demo Mode: Demo mode can be used to show how the appliance will look while functioning without running the compressor. The fan will run on low speed but all alarms and beeping will be disabled.

To engage demo mode, press and hold the up and down buttons at the same time for 10 seconds. The display will flash "dE" and "On" five times to acknowledge demo mode is active.

To disengage demo mode, press and hold the up and down buttons at the same time for 10 seconds. The display will flash "dE" and "Of" five times to acknowledge demo mode is disabled.

OPERATING INSTRUCTIONS

DOOR REVERSAL INSTRUCTIONS

If the appliance is placed on its back or side for any length of time it must be allowed to remain upright for 6 hours before plugging it in to avoid damage to the internal components.

1. Open the door to a 90° angle and remove the hinge screws. Slide the bottom of the door outward to remove it from the cabinet.
2. Remove lower hinge from the cabinet. Remove the upper right hinge from the cabinet. Remove the axis plate from the door. Remove the door stop from the bottom right side of the door. Remove the actuator from the bottom of the door.
3. Remove the screw hole covers from the top left of the cabinet and install them in the screw holes on the top right side of the cabinet. Install the upper left hinge.
4. Turn the lower hinge over and install it on the lower left side of the cabinet.
5. When reinstalling the door, it will need to be flipped 180° from its original position to ensure that the handle is on the correct side. Install the actuator at the top of the door frame. Screw holes can be found by gently pulling back the rubber gasket. Install the axis plate and the door stop on the upper right side of the door.
6. Flip the door 180° and install it on the cabinet by sliding it onto the upper hinge and sliding the bottom of the door toward the cabinet. Before securing the hinge screws ensure the top of the door is properly aligned with the top of the cabinet, that the actuator is making contact with the switch on the cabinet and that the rubber gasket makes a good seal with the cabinet all the way around.

- | |
|----------------------|
| a. Hinge screws |
| b. Axis plate |
| c. Lower hinge |
| d. Door stop |
| e. Actuator |
| f. Upper right hinge |
| g. Screw hole covers |
| h. Upper left hinge |

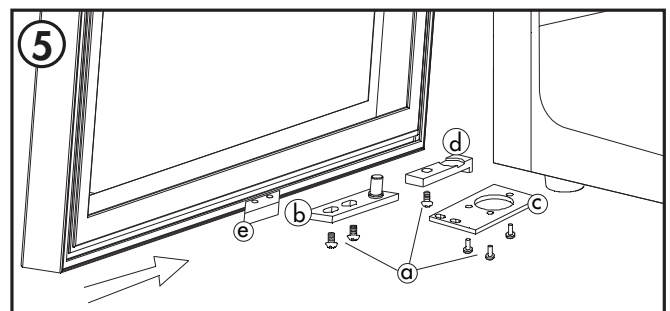
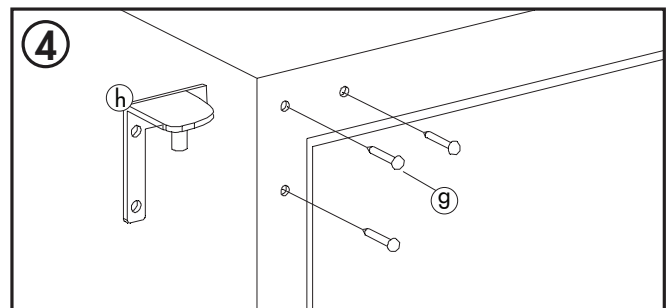
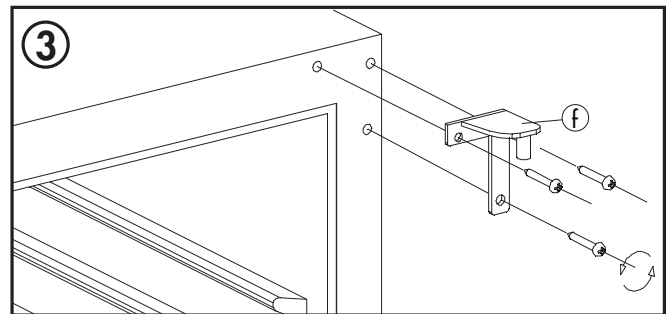
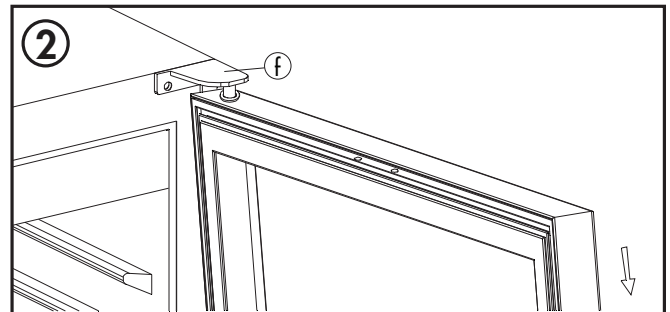
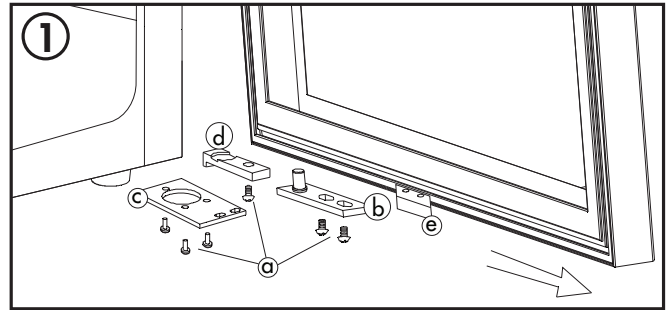

CARE & MAINTENANCE

CLEANING

Ensure the appliance is unplugged before cleaning.

- To clean the inside of the appliance, use a soft cloth and a solution of a tablespoon of baking soda to one quart of water or some mild detergent.
- Wash removable shelves in a mild detergent solution, then dry and wipe with a soft cloth.
- Clean the outside with a soft, damp cloth and some mild detergent.
- It is important to keep the area clean where the door seals against the cabinet. Clean this area with a soapy cloth. Rinse with a damp cloth and let dry.

Note: Do not use cleaners containing ammonia or alcohol on the appliance. Ammonia or alcohol can damage the appearance of the appliance. Never use any commercial or abrasive cleaners or sharp objects on any part of the appliance.

POWER FAILURE

Most power failures are corrected within a few hours and should not affect the temperature of your appliance if you minimize the number of times the door is opened. If the power is going to be off for a longer period of time, take the proper steps to protect your contents.

Note: Wait 3 to 5 minutes before attempting to restart the appliance if operation has been interrupted.

DEFROST

This appliance is equipped with an automatic defrost function and does not require manual defrosting. Defrost water from the appliance is channeled into a drip tray located above the compressor. Heat transfer from the compressor causes the defrost water to evaporate.

VACATION

- **Short vacations:** Leave the appliance operating during vacations of less than three weeks.
- **Long vacations:** If the appliance will not be used for several months, remove all items and turn off the appliance. Clean and dry the interior thoroughly. To prevent odor and mold growth, leave the door open slightly, blocking it open if necessary.

MOVING

- Ensure the appliance is empty.
- Secure the door with tape.
- Turn the adjustable leg up to the base to avoid damage.
- Protect the outside of the appliance with a blanket or similar item.
- Ensure the appliance stays in the upright position during transportation.
- If the appliance is placed on its back or side during transportation, upon reaching the destination, allow it to remain upright for 6 hours before plugging in to avoid damage to the internal components.

DISPOSAL



This marking indicates that this product should not be disposed with other household wastes throughout the EU. To prevent possible harm to the environment or human health from uncontrolled waste disposal, recycle it responsibly to promote the sustainable reuse of material resources. To return your used device, please use the return and collection systems or contact the retailer where the product was purchased. They can take this product for environmental safe recycling.

TROUBLESHOOTING

Danby Consumer Care

Consumer Helpline: 0300 303 3904

Consumer Email: danby@ukwarranty.com

Appliance warranty registration: <https://danby.warrantyonline.co.uk>

Information in this manual is subject to change without notice.

PROBLEM	POSSIBLE CAUSE
No power	<ul style="list-style-type: none">• A fuse may be blown or the circuit breaker tripped• Plug not fully inserted into the wall outlet
Internal temperature not cold enough Appliance runs continuously	<ul style="list-style-type: none">• Door is not shut properly or opened excessively• Exhaust vent is obstructed• Recently added a large quantity of warm contents to the cabinet• Close proximity to heat source or direct sunlight• Ambient temperature or humidity is very high• Possible system leak, evaporator fan failure or compressor failure
Condensation on the cabinet or door	<ul style="list-style-type: none">• Door is not shut properly or opened excessively• Ambient temperature or humidity is very high
Excessive noise	<ul style="list-style-type: none">• Appliance is not level• Gurgling noises are normal; this is the coolant moving through the lines in the cabinet• Contraction and expansions of the inside walls can cause crackling or popping noises, especially if the ambient temperature is very warm
Door will not close	<ul style="list-style-type: none">• Appliance is not level• Door gasket is dirty or bent• Shelves are not pushed all the way in• Door swing was reversed and not properly reinstalled

WARRANTY

**Congratulations on the purchase of your new Danby product.
This appliance comes with a 2 year warranty.**

Please call 0300-303-3904 to register your product and receive full terms and conditions.

This quality product is warranted to be free from manufacturer's defects in material and workmanship, provided that the unit is used under the normal operating conditions intended by the manufacturer. This warranty is available only to the person to whom the unit was originally sold by a Danby Products authorized dealer.

TERMS OF WARRANTY

During the first twenty-four (24) months, any functional parts of this product found to be defective will be repaired or replaced, at warrantor's option, at no charge to the original purchaser.

EXCLUSIONS

Save as herein provided, by Danby, there are no other warranties, conditions, representations or guarantees, express or implied, made or intended by Danby or its authorized distributors and all other warranties, conditions, representations or guarantees, including any warranties, conditions, representations or guarantees under any Sale of Goods Act or like legislation or statute is hereby expressly excluded. Save as herein provided, Danby shall not be responsible for any damages to persons or property, including the unit itself, howsoever caused or any consequential damages arising from the malfunction of the unit and by the purchase of the unit, the purchaser does hereby agree to indemnify and hold harmless Danby from any claim for damages to persons or property caused by the unit.

There are no express warranties other than those on the face here of and described above. No warranties whether expressed or implied, including but not limited to, any implied warranties of merchantability or fitness for a particular purpose, shall extend beyond the respective warranty periods provided above. This warranty does not affect the consumer's legal rights under applicable National legislation.

Service administered by UK Warranty Limited
Pacifica House, Rainton Business Park
Houghton Le Spring, England, DH4 5RA
danby.warrantyonline.co.uk

0300-303-3904
08/18

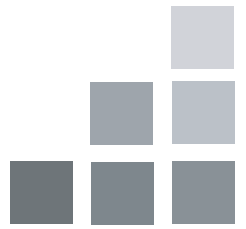

MODEL
DBC122KD1BSS

Distributed by Exertis (UK) Ltd.
Technology House, Magnesium Way, Hampton, Burnley, England, BB12 7BF