



# TOPENS<sup>®</sup>

TC175P

## Wired Keypad User Manual



**Controlled Access, Enhanced Safety !**



## Product Description

The wired touch panel keypad is an intelligent access control device that features advanced contactless RFID transponder technology for secure, keyless gate access. To operate the gate, simply enter a short password or tap a compatible RFID card (not included). The keypad can be powered by either the gate opener's control board or an external 12-24VDC power source.



## 1 SPECIFICATIONS AND DIMENSIONS

<b>Operating Voltage</b>	12-24VDC $\pm$ 10%
<b>Operating Current</b>	< 100 mA
<b>Relay Output</b>	SPDT, 3A 120VAC / 24VDC
<b>Relay Unlock Output Time</b>	0.2-99 seconds (Adjustable)
<b>User Capacity</b>	4000 Users
<b>Card Type (Alternative)</b>	125KHz EM or ID Card / Tag
<b>Card Reading Distance</b>	1-15cm (0.4-6")
<b>Working Temperature</b>	-20°C ~ +50°C (0°F to 120°F)

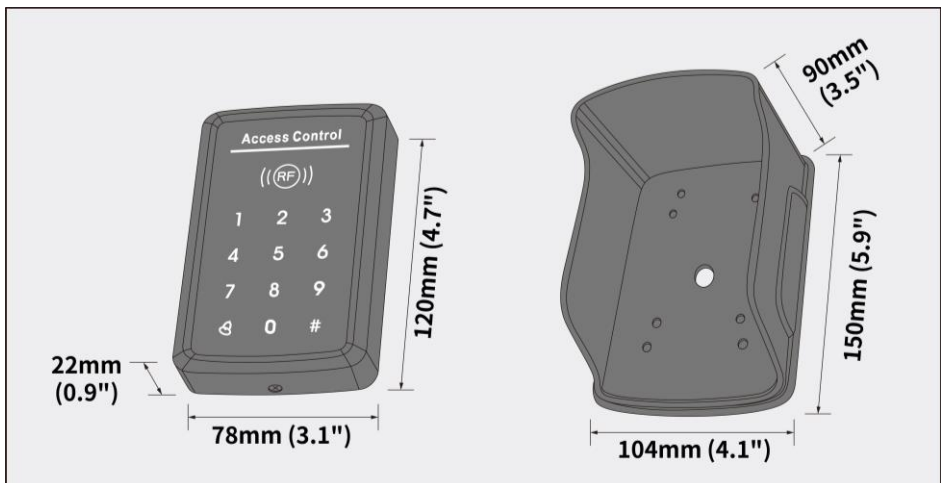

## 2 KEYPAD ILLUSTRATION

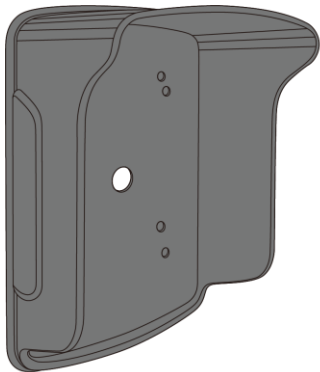

Waterproof Housing

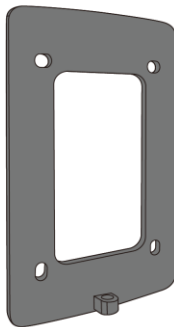

Back Cover



Main Functional Unit

## 3 DEFAULT SETTINGS OF THE KEYPAD

<b>Programming Password</b>	123456
<b>Common Access Password</b>	None
<b>Backlight</b>	Auto (Optional Setting)
<b>Relay Unlock Output Time</b>	5 Seconds
<b>W26 Port</b>	Input (Optional Feature)
<b>Security Mode</b>	OFF
<b>Open Mode</b>	Card or Access Password

## 4 POWER LIGHT AND BUZZER INDICATORS

Power Light Indicators (located at the “RF” position on the keypad)

Light Description	Access Control Status
Red light flashes every 1 second (slow flash)	Standby mode
Red light remains steadily on	Programming mode
Green light remains steadily on during open time	Unlocking state
Green light flashes every 0.5 seconds (fast flash)	Waiting for further action

## Buzzer Sound Indicators

Sound Description	Indication
1 short beep	Valid input
3 short beeps	Invalid input
1 long beep	Programming successful
Continuous long beep	Restoring factory programming password

## 5 TERMINAL FUNCTIONS OF THE KEYPAD

### JP1 Terminals - For Door Access Control System Only

No.	Terminal	Wire Color	Function
1	12/24V	Red	Power+ (12-24VDC Positive)
2	GND	Black	Power- (12-24VDC Negative)
3	PUSH	Blue	Low Level Output
4	OPEN	Yellow	Door Release
5	BEL+	Grey	Bell
6	BEL-	White	Bell

### JP2 Terminals - For Gate Openers and Door Access Control Systems

No.	Terminal	Wire Color	Function
1	12/24V	Red	Power+ (12-24VDC Positive)
2	GND	Black	Power- (12-24VDC Negative)
3	D0	Green	Wiegand DATA0
4	D1	White	Wiegand DATA1
5	NC	Brown	Relay Normally Closed Output
6	COM	Blue	Relay Common Output
7	NO	Purple	Relay Normally Open Output

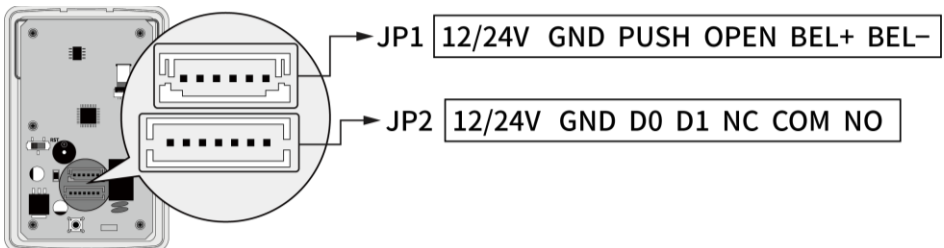

## 6 INSTALLING THE KEYPAD

**STEP 1:** Remove the screw at the bottom of the keypad and detach the back cover from the unit.

**STEP 2:** Position the back cover on the wall or post. Drill four holes aligned with the mounting points on the cover, then insert four plastic anchors (not included) into the drilled holes.

**STEP 3:** Attach the included waterproof gasket to the back of the waterproof housing.

**STEP 4:** Route the extension cable (not included) through the hole in the waterproof housing and the back cover. Secure both components to the wall or post using screws (not included).

**STEP 5:** Connect the wires from the JP2 terminals of the keypad to the gate opener's control board via the extension cable.

- ◆ Connect the "COM" and "NO" terminals to the push button terminals on the gate opener's control board.
- ◆ Connect the "12/24V" and "GND" terminals to the auxiliary power output on the control board, or to an external power source.
- ◆ For detailed wiring instructions with a TOPENS gate opener, refer to the *Accessory Connection* section in the corresponding gate opener's installation manual.

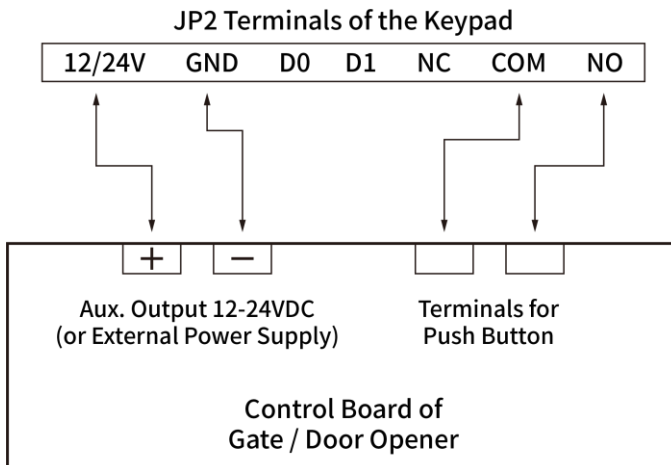

**STEP 6:** Reattach the keypad to the back cover and fasten it securely.

**Notes:**

- Use a 4C x 0.3 mm<sup>2</sup> (22AWG) cable for wiring (not included), and keep the wire length within 15 meters (50 feet) for optimal performance. For longer distances, use thicker, shielded cables to maintain signal stability. The maximum allowable distance between the keypad and the control board is 30 meters (100 feet).
- Mounting hardware is NOT included.

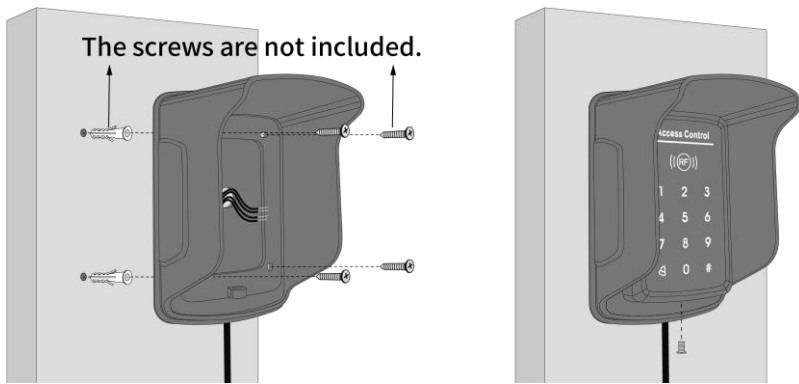

## **7 PROGRAMMING THE KEYPAD**

◆ The keypad supports three operating modes:

**01 - Card Only**

Swipe the card directly to operate the gate.

**02 - Card or Access Password (default)**

Either swipe the card to operate the gate, or enter the Access Password (common access password or PIN), then press the “#” button.

**03 - Card + Card Password**

Swipe the card, enter the associated Card Password, and press the “#” button to operate the gate.

Choose and set the mode that best suits your access needs.

- ◆ There are three types of passwords used with the keypad: **Programming Password, Access Password, and Card Password.**
  - **Programming Password:** Used for system programming.
  - **Access Password:** Used to operate the gate opener when the keypad is in “Card or Access Password” mode. It includes: **Common Access Password** - Shared by all users, and **Private Access Password (PIN)** - Assigned to individual users.
  - **Card Password:** Required after swiping an RFID card when the keypad is set to “Card + Card Password” mode.
- ◆ User ID represents the number assigned to each Private Access Password. It is a 4-digit auto-generated number starting from 0001 and increases sequentially with each new user added. Deleting users does not affect the sequence. The Common Access Password does not have an associated User ID.
- ◆ All passwords must be 3 to 6 digits in length. The factory default Programming Password is “123456” .

### Program a New Programming Password

# Old Programming Password # 0 New Programming Password #  
 New Programming Password #

### Add a Card

# Programming Password # 1 Read Card #

**Note:** *If adding multi cards, read them consecutively.*

### Add a New Common Access Password

# Programming Password # 21 New Common Access Password #

**Note:** *Only one Common Access Password can be set at a time. It cannot be deleted directly, but you can change it by resetting a new one. The password will be removed only when the keypad is reset to factory default settings.*

### Add a New Private Access Password (PIN)

# Programming Password # 22 Private Access Password #

**Note:** *Up to 4,000 PINs can be configured.*

### Add a Card by Entering Card Number

# Programming Password # 23 Card Number #

**Note:** The card number should be 8 or 10 digits long and will be automatically recognized by the keypad.

### Add Multiple Cards by Entering Card Number Range

# Programming Password # 24 Start Card Number Card Quantity #

**Note:** Enter a 4-digit number as the card quantity. For example, to add 20 cards, input 0020.

### Add a “Card + Card Password” User

# Programming Password # 3 Read Card Card Password #

**Note:** Enter a 3- to 6-digit number as the Card Password. You can change it as follows:

- ◆ After reading the card and entering the current Card Password to open the gate, press and hold the “#” button on the keypad within 5 seconds, until the green light flashes rapidly.
- ◆ Enter “New Card Password # New Card Password #” . A long beep will confirm that the New Card Password has been set successfully.

### Delete All Users

# Programming Password # 40 0000 #

**Note:** All cards and PINs will be deleted, except for the Common Access Password.

### Delete a User by Reading Card

# Programming Password # 41 Read Card #

**Note:** If deleting multi cards, read them consecutively.

### Delete the User by Entering User ID Number

# Programming Password # 42 User ID Number #

### Delete the User by Entering Card Number

# Programming Password # 43 Card Number #

### Delete the User by Entering PIN

# Programming Password # 44 PIN #

## Delete All PINs

# Programming Password # 45 1111 #

## Change the “Relay Unlock Output”

# Programming Password # 5 XX #

**Note:** XX must be a 2-digit number, with a maximum value of 99. If 00 is entered, the signal output time will be 0.2 seconds.

## Set Open Mode

# Programming Password # 6 XX #

**Note:** XX must be a 2-digit number: 01-Card only; 02-Card or Access Password; 03-Card + Card Password

## Set as a Card Reader (Optional)

# Programming Password # 6 04 #

**Note:** The keypad can function as a card reader with standard Wiegand 26 (W26) output.

## Set Security Function and Anti-dismantle Alarm (Optional)

# Programming Password # 7 XX #

### Notes:

- ◆ XX must be a 2-digit number: 01-Security function OFF; 02-Security function ON; 03-Anti-dismantle alarm OFF; 04-Anti-dismantle alarm ON.
- ◆ When the security function is enabled, the keypad will lock for 5 minutes after 10 consecutive attempts to read an unauthorized card or enter an incorrect access password.

## Set Backlight (Optional)

# Programming Password # 8 XX #

**Note:** XX must be a 2-digit number: 01-Normally ON; 02-Normally OFF.

## Set Power Light (Optional)

# Programming Password # 8 XX #

**Note:** XX must be a 2-digit number: 04-Normally OFF; 05-Normally ON.

## Reset to Factory Default Settings

# Programming Password # 8 99 #

**Note:** This will reset all settings to factory defaults, except for the Programming Password.

## Reset to Factory Programming Password

**STEP1:** Power off the keypad. Then, turn the RST DIP switch on the back of the keypad to the right.

**STEP2:** Power on the keypad. The buzzer will emit three long beeps, and the green light will flash rapidly.

**STEP3:** Power off the keypad again, then return the DIP switch to the left.

**STEP4:** Power on the keypad once more. The Programming Password will be reset to the factory default value: “123456” .

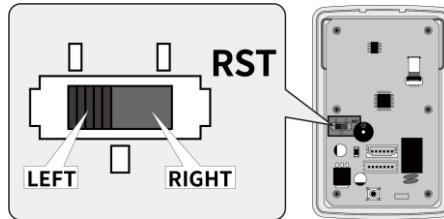

## Feedback & Review

Your comments and suggestions are important to us as they help us provide the best possible service.

Should you have any need to contact us, the info below will help you get in touch:



TOPENS Website

[www.topens.com](http://www.topens.com)

Contact Us:

E-mail: [support@topens.com](mailto:support@topens.com)

*Kindly include your purchase channel, order #, gate information, issue description and your contact information. All your concerns will be replied within 24 hours.*

Tel: +1 (888) 750 9899 (Toll Free USA & Canada)