

# CONTENTS

## ***Your induction hob***

Introduction	4
Control panel	5
Description	6

## ***Safety instructions***

What you should pay attention to	7
Connection and repair	7
During use	7
Temperature safety	9
Cooking-time limiter	9

## ***Use***

Using the touch controls	10
Induction cooking	10
How does induction work	11
Induction Noises	11
Pans	12

## ***Operation***

Switching on the hob and setting the power	14
Residual warmth indicator	14
Boost	15
Two cooking zones behind each other	15
How to bridge the adaptive induction zones	16
Switching off the hob	16
Stand-by mode	17
Eco stand-by mode	17
Child lock	18
Pause	18
Recognizing a mode	19
Timer / Kitchen timer	20
Switching on and off the beep	22
Automatic cooking programs	23
Healthy cooking	27
Cooking settings	28

## ***Maintenance***

Cleaning	29
----------	----

## ***Faults***

General	30
Troubleshooting table	30

## ***Installation***

What you need to consider	32
Electrical connection	36
Building in	37
Technical details	38

## ***Environmental aspects***

Disposal of packaging and appliance	39
-------------------------------------	----

# YOUR INDUCTION HOB

## *Introduction*

---

This hob has been designed for the real lover of cooking. Cooking on an induction hob has a number of advantages. It is easy, because the hob reacts quickly and can also be set to a very low power level. Because, moreover, it can also be set to a high power level, it can bring dishes to the boil very quickly. The ample space between the cooking zones makes cooking comfortable.

Cooking on an induction hob is different from cooking on a traditional appliance. Induction cooking makes use of a magnetic field to generate heat. This means that you cannot use just any pan on it. The pans section gives more information about this.

For optimum safety the induction hob is equipped with several temperature protections and a residual heat indicator, which shows which cooking zones are still hot.

This manual describes how you can make the best possible use of the induction hob. In addition to information about operation, you will also find background information that can assist you in using this product. You will also find cooking tables and maintenance tips.

**Read the manual thoroughly before using the appliance and store it in a safe place for future reference.**

The manual also serves as reference material for service technicians.

**Please, therefore, stick the appliance identification card in the space provided, at the back of the manual.** The appliance identification card contains all the information that the service technician will need in order to respond appropriately to your needs and questions.

Enjoy your cooking!

## YOUR INDUCTION HOB

### Control panel

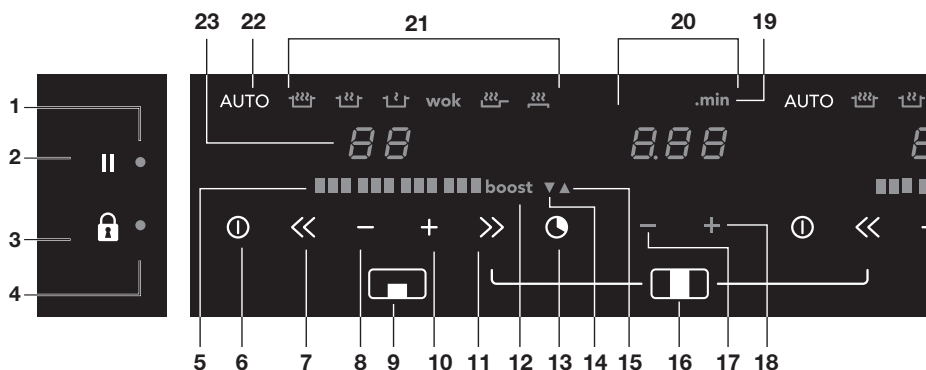

1. Pause indicator
2. Pause button
3. Childproof lock/Eco stand-by button
4. Childproof lock indicator/Eco stand-by indicator
5. Level indicator in cubes
6. On/off button
7. Reduce the power quickly
8. Reduce the power
9. Cooking zone indicator
10. Increase the power
11. Increase the power quickly
12. Boost
13. Timer/alarmclock button
14. Alarmclock indicator
15. Cooking time indicator
16. Bridge function (Two zones are connected; this creates one 'big' zone. Control 2 zones with one slider)
17. 'Reduce the time' button
18. 'Raise the time' button
19. 'Minutes after dot' indicator
20. Timer/alarmclock
21. Auto functions (see page 23-27; 'Automatic cooking programs')
22. Auto button
23. Level indicator

## YOUR INDUCTION HOB

### *Description*

Hi1683g

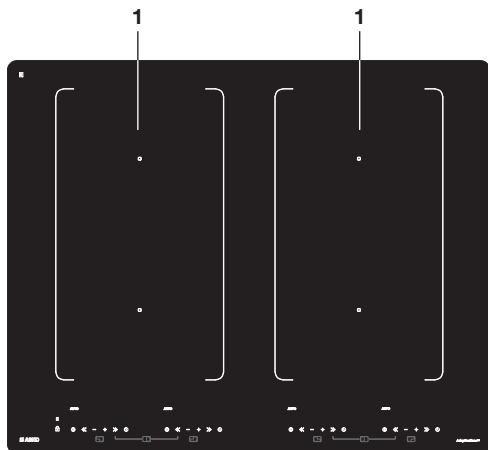

Hi1983g

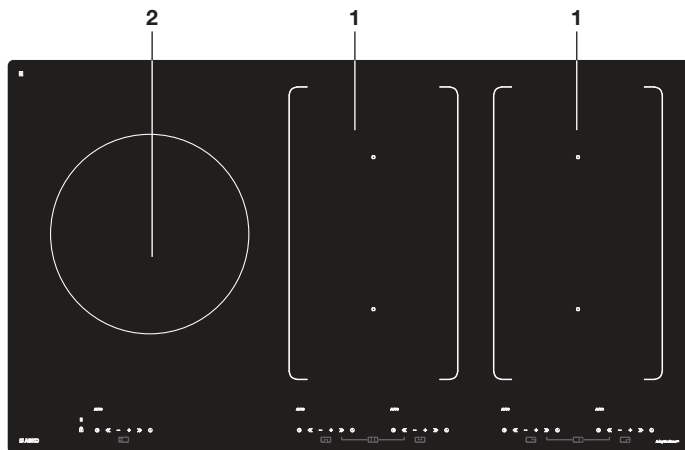

1. Adaptive zone 180 x 220 mm 3,7kW (zones that can be connected)
2. Cooking zone Ø260 5,5 kW (double ring)

## SAFETY

### What you should pay attention to



- Induction cooking is extremely safe. Various safety devices have been incorporated in the hob such as a residual heat indicator and a cooking time limiter. There are nevertheless a number of precautions you should take.
- ASKO cannot be held liable for damage resulting from incorrect or improper use or operation of the appliance.

### Connection and repair



- This appliance may only be connected by a qualified professional.
- Never open the casing. The casing may only be opened by the service technician.
- Disconnect the electricity from the appliance before starting any repair work. Preferably unplug the appliance, switch the (automatic) fuse(s) off or, in the event of a permanent connection, set the switch in the power supply lead to zero.

### During use



- **WARNING:** The appliance and its accessible parts become hot during use. Care should be taken to avoid touching heating elements. Children less than 8 years of age shall be kept away unless continuously supervised.
- This appliance can be used by children aged from 8 years and above and persons with reduced physical, sensory or mental capabilities or lack of experience and knowledge if they have been given supervision or instruction concerning use of the appliance in a safe way and understand the hazards involved. Children shall not play with the appliance. Cleaning and user maintenance shall not be made by children without supervision.
- **WARNING:** Unattended cooking on a hob with fat or oil can be dangerous and may result in fire. NEVER try to extinguish a fire with water, but switch off the appliance and then cover flame e.g. with a lid or a fire blanket.
- **WARNING:** Danger of fire: do not store items on the cooking surfaces.
- **WARNING:** If the surface is cracked, switch off the appliance to avoid the possibility of electric shock.
- Metallic objects such as knives, forks, spoons and lids should not be placed on the hob surface since they can get hot.
- After use, switch off the hob element by its control and do not rely on the pan detector.
- Do not use the hob in temperatures below 5 °C.

## SAFETY

- This cooking appliance is designed for household use. It is to be used for food preparation only.
- When you use the hob for the first time you will notice a “new smell”. This is normal. If the kitchen is well ventilated the smell will soon disappear.
- Remember that if the hob is used on a high setting the heating time will be incredibly short. Do not leave the hob unattended if you are using a zone on a high setting.
- Ensure there is adequate ventilation while the hob is in use. Keep all natural ventilation openings open.
- Do not allow pans to boil dry. The hob itself is protected against overheating but the pan will get very hot indeed and could be damaged. The guarantee does not cover any damage caused by a pan boiling dry.
- Ensure that there is several centimetres clearance between the hob and the contents of the drawer.
- Do not keep anything combustible in the drawer under the hob.
- Make sure that flexes of electrical appliances, such as a mixer, cannot touch the hot cooking zone.
- Never flambé food under the cooker hood. The high flames could cause a fire, even if the cooker hood is switched off.
- The ceramic top is extremely strong, but not unbreakable. A spice jar or pointed utensil falling on it, for example, could cause it to break.
- Keep magnetizable objects (credit cards, bank cards, floppy disks, etc.) away from the appliance. We advise anyone with a pacemaker to consult their cardiologist before using an induction hob.
- Never use a pressure cleaner or steam cleaner to clean the hob.
- Never let an empty pan stand on a hotplate that is switched on. While the hotplate is protected and will switch itself off, the pan will be extremely hot. The pan could be damaged.
- The appliance is not intended to be operated by means of an external timer or separate remote-control system.
- A small object like a pan that is too small (diameter of bottom smaller than 12 cm), a fork or a knife will not be recognised by the appliance. The display continues to flash and the cooking zone will not switch on.
- If the connecting cable is damaged, it may only be replaced by the manufacturer, the manufacturer’s service organisation or equivalently qualified persons, in order to avoid dangerous situations.
- Accessible parts may become hot during use. To avoid burns young children should be kept away.

## SAFETY

- A cooking zone can remain hot for several minutes after use. Avoid touching the hot areas during this time.

### For users with heart pacemakers and active implants

- The functioning of the hob conforms to current electromagnetic interference standards and thus is in total compliance with legal requirements. In order to avoid interference between your cooking hob and a pacemaker, your pacemaker must be designed and programmed in compliance with the regulations that apply to it. Consequently, we can only guarantee that our own product is compliant. With regard to the compliance of the pacemaker or any potential incompatibility, you should obtain information from the manufacturer or your attending physician.

### Temperature safety

- A sensor continuously measures the temperature of certain parts of the hob. Every cooking zone is equipped with a sensor that measures the temperature of the bottom of the pan to avoid any risk of overheating when a pan boils dry. In case of temperatures rising too high, the power is reduced automatically or the hob switches off automatically.

### Cooking-time limiter



- The cooking-time limiter is a safety function of your cooking appliance. It will operate if you forget to switch off your hob.
- Depending on the setting you have chosen, the cooking time will be limited as follows:

Setting	The cooking zone switches automatically off after:
1 and 2	9 hours
3, 4 and 5	5 hours
6, 7 and 8	4 hours
9	3 hours
10	2 hours
11 and 12	1 hour

The cooking-time limiter switches the cooking zones off if the time in the table has elapsed.

Setting	The cooking zone switches automatically to setting 12 after:
boost	10 minutes

## Using the touch controls

The touch controls may take some getting used to if you are used to other (rotary) controls. Place your fingertip flat on the control to achieve the best results. You do not have to apply any pressure.

The touch sensors only react to the light pressure of a fingertip. Do not operate the controls with any other objects.

## Induction cooking

### **Induction cooking is fast**

- To start you will be surprised by the speed of induction cooking. Especially at higher settings, foods and liquids will boil very rapidly. It is best not to leave pans unattended to avoid them boiling over or boiling dry.

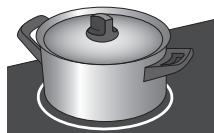

*No heat loss and cold handles with induction cooking.*

### **The power will be adjusted**

- In the case of induction cooking, it is only the part of the zone on which the pan stands that is used. If you use a small pan on a large zone, the power will be adjusted to the diameter of the pan. The power will thus be lower and it will take longer before the food in the pan comes to the boil.

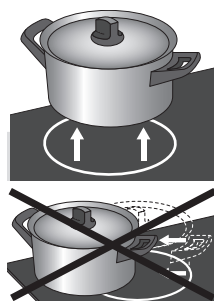

### **Attention**

- Grains of sand may cause scratches which cannot be removed. Only put pans with a clean base on the cooking surface and always pick pans up to move them.
- Do not use the hob as a worktop.
- Always keep the lid on the pan when cooking, in order to avoid energy loss.

## How does induction work

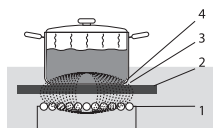

The coil (1) in the hob (2) generates a magnetic field (3). By placing a pan with an iron base (4) on the coil, a current is induced in the base of the pan.

A magnetic field is generated in the appliance. By placing a pan with an iron base on a cooking zone, a current is induced in the pan base. This induced current generates heat in the base of the pan.

### Easy

The electronic controls are accurate and easy to set. On the lowest setting, you can melt chocolate directly in the pan, for example, or cook ingredients that you would normally heat in au bain-marie.

### Fast

Thanks to the induction hob's high power levels, bringing food to the boil is very quick. Cooking food through takes just as long as for other types of cooking.

### Clean

The hob is easy to clean. Because the cooking zones do not get any hotter than the pans themselves, food spills cannot burn on.

### Safe

The heat is generated in the pan itself. The glass top does not get any warmer than the pan. This means that the cooking zone is considerable cooler compared to that from a Ceramic hob or a gasburner. Once a pan has been taken away, the cooking zone cools down quickly.

## Induction Noises

Whistling Noise may be emitted if bridged zones are used or if the booster function is used.

### A ticking sound

This is caused by the capacity limiter on the front and back zones. Ticking can also occur at lower settings.

### Pans are making noise

- Pans can make some noise during cooking. This is caused by the energy flowing from the hob to the saucepan. At high settings this is perfectly normal for some pans. It will not damage either the pans or the hob.

- If the pan base is made from layers of different material (i.e sandwich base), it might emit a crackling sound.

### The fan is making noise

To enlarge the lifespan of the electronics, the appliance is equipped with a fan. If you use the appliance intense, the fan is activated to cool down the appliance and you will hear a buzzing sound. The fan runs on for several minutes after the hob has been switched off.

## Pans

### Pans for induction cooking

Induction cooking requires a particular quality of pan.



#### Attention

- Pans that have already been used for cooking on a gas hob are no longer suitable for use on an induction hob.
- Only use pans that are suitable for electric and induction cooking with:
  - a thick base (minimum 2.25 mm);
  - a flat base.



#### Tip

You can check for yourself whether your pans are suitable using a magnet. A pan is suitable if the base of the pan is attracted by the magnet.

Suitable	Unsuitable
Special stainless steel pans	Earthenware
Class Induction	Stainless steel
Hard-wearing enamelled pans	Porcelain
Enamelled cast-iron pans	Copper
	Plastic
	Aluminium



#### Attention

Be careful with enamelled sheet-steel pans:

- the enamel may chip (the enamel comes loose from the steel), if you switch the hob on at a high setting when the pan is (too) dry;
- the base of the pan may warp - due, for example, to overheating or to the use of too high a power level.



### **Attention**

Never use pans with a uneven base. It is highly recommended that the pans have a flat base. A hollow or rounded base can interfere with the operation of the overheating protection, so that the appliance becomes too hot. This may lead to the glass top cracking and the pan base melting. Damage arising from the use of unsuitable pans or from boiling dry is excluded from the guarantee.

### **Minimum pan diameter**

The diameter of the bottom of the pan must be at least 12 cm. You will achieve the best results by using a pan with the same diameter as the zone. If a pan is too small the zone will not work.

### **Pressure cookers**

Induction cooking is very suitable for cooking in pressure cookers. The cooking zone reacts very quickly, and so the pressure cooker is quickly up to pressure. As soon as you switch a cooking zone off, the cooking process stops immediately.

## OPERATION

### Switching on the hob and setting the power

The cooking zones have 12 levels. Beside it there is a level 'boost'.

1. Put a pan on a cooking zone.
2. Press the child lock button.  
*You will hear a single beep.*
3. Press the on/off button of the cooking zone concerned.  
*A flashing '-' appears in the display and you will hear a single beep.*  
*If no further action is taken, the cooking zone will automatically switch off after a few seconds.*
4. Press the + or - button, or the << or >> button to select the desired setting. The cooking zone starts automatically in the level that has been set (when a pan is detected).
  - ▷ If you press the + or - button first, level 6 appears.
  - ▷ If you press the >> button first, level 12 + 'boost' appear in the display. This is power level 'boost' and you can use this setting if you want to bring dishes to the boil quickly (see page 15).
  - ▷ If you press the << button first, level 1 will appear.



#### Tips

- With the + or - button you can increase or reduce the power setting step by step. By pressing the << or >> button, you can increase or reduce the power setting quick.
- Press and hold the << , - , + or >> button to set the desired power level more quickly.

#### Pandetection

If the hob does not detect a (ferrous) pan after the cooking power has been set, the display will blink and the hob will remain cold. If a (ferrous) pan is not placed on the cooking zone within 1 minute, the cooking zone will automatically switch off (see also page 12 and 13 'Pans').

### Residual warmth indicator



A cooking zone that has been used intensively will retain heat for several minutes after it has been switched off. An 'H' appears in the display as long as the cooking zone is hot.

## OPERATION

### Boost

You can use the 'boost' function to cook at the highest power level during a short period of time (max.10 minutes). After the maximum boost time the power will be reduced to setting 12.



#### Switching on 'boost'

1. Put a pan on a cooking zone.
2. Press the >> button immediately after you have switched on the zone.

*Level 12 and 'boost' appear in the display.*

- If a cooking zone has already been set to a power level and you want to use 'boost', press several times the >> button or the + button of the cooking zone concerned.

#### Switching off 'boost'

*'Boost' has been switched on, the display shows level 12 and 'boost'.*

1. Press the << button or the - button.

*In the display you will see a lower level.*

#### Or:

2. Press the on/off button of the cooking zone you want to switch off.

*You will hear a beep and the level in the display disappears.*

*The cooking zone has been switched off completely.*

### Two cooking zones one in front of the other

- Two cooking zones one in front of the other affect each other. When both of these cooking zones are switched on at the same time, the power is automatically shared between them. The first set cooking zone will remain at the set setting at all times. The maximum set setting for the cooking zones to the front or back that is added later, depends on the setting of the first cooking zone. When you have reached the maximum amount of cooking setting combinations, the last set setting will start to flash and is automatically lowered to the highest possible setting.
- Two cooking zones alongside each other have no effect on each other. You can set both cooking zones on a high setting.
- If the adaptive zones are bridged, they cannot be set to 'boost' and the menu functions cannot be used.

### How to bridge the adaptive induction zones



The adaptive induction zones can be bridged. Both zones in the front and the back will have the same settings after activating this function (they are now connected; one big zone for a large cooking pan).

- If the adaptive zones are bridged, they cannot be set to 'boost' and the menu functions cannot be used.

Use a (fish) pan where at least one of the centre/middle positions of the vario zones is covered.

#### **Activating the bridge mode**

1. Put a large cooking pan on both cooking zones. Make sure the zones are covered correct.
2. Switch on the cooking zone in the front.
3. Hold two keys down at the same time (for a few seconds): first press the << button on the rear adaptive zone and then immediately the >> button on the front adaptive zone.

*'BR' appears in the display of the zone at the back. Now you can use the controls of the zone in the front to set the power for both adaptive zones.*

4. Set the power using the + or - button, or using the << or >> button of the zone in the front. Both zones are set to the same power.



#### **Deactivating the bridge mode**

1. Touch simultaneously the >> button of the adaptive zone in the front and the << button of the adaptive zone at the back to deactivate the bridge mode.

*The zone in the front will continue with the power that has been set in bridge mode.*

**Or:**

2. Press the on/off button of the cooking zone you want to switch off.  
*You will hear a beep and the level in the display disappears.  
The cooking zone has been switched off completely.*

### Switching off

#### **Switching off one cooking zone**

Press the on/off button of the cooking zone you want to switch off.  
*You will hear a beep and the level in the display disappears.*

- If all cooking zones have been switched off in this way, the hob will automatically be in the stand-by mode (also refer to 'stand-by mode').

## OPERATION

### Switching off all cooking zones

Press the child lock button to switch off all the cooking zones at the same time.

*You will hear a beep. The red childproof lock indicator next to the child lock button will blink very slowly.*

- The induction hob is now in eco stand-by mode (see also 'eco stand-by mode').

### Stand-by mode

In stand-by mode the induction hob is switched off. You can switch to the stand-by mode from the eco stand-by mode, or by switching off all cooking zones.

From the stand-by mode you can directly start cooking by pressing the on/off button of the desired cooking zone.



### Switching the hob from the eco stand-by mode to the stand-by mode

*The red light next to the child lock button keeps slowly going on and off.*

- Press the child lock button for a short while to switch to the stand-by mode.

*A single beep will be heard. All lights on the hob are off.*

### Eco stand-by mode

In the eco stand-by mode the hob is switched off and it uses as little energy as possible.

The hob can also be switched to the eco stand-by mode from the stand-by mode and when cooking zones are still active.



### Did you know that

The hob uses less than 0,5 Watt in the eco- stand-by mode. That is even less than in the stand-by mode of the hob.

### Switching the hob to the eco stand-by mode

- Press the child lock button.

*A will hear a single beep. The eco stand-by mode is active, the red light next to the child lock button keeps slowly going on and off.*

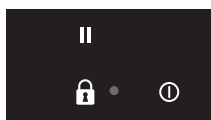

## OPERATION

From the eco stand-by mode you can't immediately start cooking. To be able to, the hob first needs to be switched to the stand-by mode.



### Did you know that

After 30 minutes in the stand-by mode the hob will automatically switch to the eco stand-by mode to prevent unnecessary energy consumption.

## Child lock

Your induction hob is equipped with a childproof lock that lets you lock the appliance. It prevents unintended switching on.

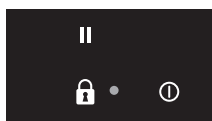

### Switching on the child lock

1. Press the child lock button for two seconds.

*You will hear a double beep. All buttons are active now, except for the child lock button. The hob first switches to the eco stand-by mode and then to the childproof lock mode. The red light is constantly on.*

2. Press the button again for 2 seconds to get the hob of the childproof lock.

*A single beep will be heard. The hob is now in the stand-by mode. The red light next to the child lock button is out.*



### Tip

Set the hob to the child lock mode before cleaning the hob to prevent it from accidentally switching on.



### Did you know that

When the hob is set to the child lock, it uses just as little energy as when it is in the eco stand-by mode.

## Pause

With this pause function, you can set the entire hob to 'pause' for 5 minutes during cooking. In this way you can leave or clean the hob in a safe way during a short period of time, without losing settings.

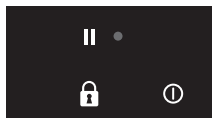

## Switching the hob to the pause mode

- Press the pause button once.  
*You will hear a double beep, the settings change into a lower setting and the red light next to the pause button flashes.*
  - Any set timers/kitchen timers stop. All cooking zones are automatically changed to a lower setting.
  - All buttons are inactive except for the child lock button and the pause button.
  - The on/off button of the individual cooking zones also remain active, they do however react with a delay of two seconds.
- If you press the pause button again within 5 minutes, the paused cooking process will be resumed.  
*You will hear a double beep, the hob resumes the settings as they were set before the pause.*
- If you do not undertake any further action within 5 minutes:  
*All active cooking zones will be switched off automatically. After that the pause button will keep flashing for 25 minutes to indicate the cooking processes have been ended by the pause mode. The hob automatically switches from the pause mode to the eco stand-by mode after 25 minutes.*

## Recognizing a mode

<b>The stand-by mode</b>	Not a single light is lit.
<b>The eco stand-by mode</b>	The red light next to the child lock button keeps slowly going on and off.
<b>The child lock mode</b>	The red light next to the child lock button is constantly on.
<b>The pause mode</b>	The red light next to the pause button flashes.

## OPERATION

### Timer / Kitchen timer

The timer/alarmclock button of each cooking zone has two functions:

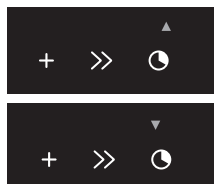

The timer function	The kitchen timer function
This function can be recognized by the red small arrow pointing up.	This function can be recognized by the red small arrow pointing down.
The time increases in the timer function.	The time decreases in the kitchen timer function.
The timer cannot be linked to a cooking zone.	The kitchen timer can be linked to a cooking zone. This means the cooking zone switches off if the set time has passed.
When the timer button is pressed, the timer function automatically switches on after 3 seconds if you do nothing.	The kitchen timer function can be reached from the timer function by pressing the red + button or red - button.



#### Attention

- Per set of two cooking zones (front and back) one timer/kitchen timer is available. In the case of a 5th cooking zone, the 5th cooking zone has its own timer/kitchen timer.
- The timer/kitchen timer can only be linked to one of both cooking zones per set of two cooking zones.
- The timer-/kitchen timer function can also be used without activating an accompanying cooking zone.

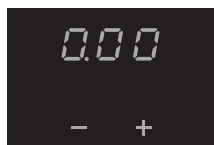

#### Switching on the timer

1. Press the timer/alarmclock button of the cooking zone once.  
*The display of the timer lights up and you'll see three zeroes flashing. Under that appears a + and -.*
- If you do not set a time with the + or - button, the timer will start running automatically after 3 seconds. The timer can go as far as 9 hours and 59 minutes.  
*The red arrow pointing up lights up and the time increases.*
2. Press the timer/alarmclock button of the cooking zone again, to switch it off.

## OPERATION

### Switching on the kitchen timer

1. Press the timer/alarmclock button of the cooking zone once.
2. Press the + or - button to switch from the timer function to the kitchen timer function. After that you can set the desired cooking time with the + button. Then you can change the set time with the - button.

*The red small arrow pointing down lights up. Time is counting down.*

3. Press the timer/alarmclock button of the cooking zone again, to switch it off.

### Attention



- The kitchen timer is linked to the cooking zone if the accompanying cooking zone is switched on.
- If the kitchen timer is linked to a cooking zone, the cooking zone will switch off after the set time has passed.

*The kitchen timer alarm beeps for a quarter of an hour while decreasing as the time passes, while '0.00' and the arrow pointing down keeps flashing. Press the timer/alarm clock button of the cooking zone again, to switch off the kitchen timer alarm.*

### Setting the cooking time

- Switch the kitchen timer on.

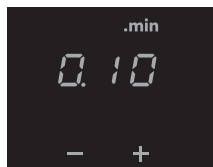
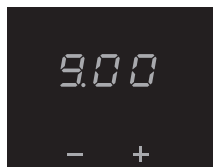

Button	Steps of x per button contact	Time
+	x = 1 minute	0.00 to ...
-	x = 10 seconds	5.00 - 0.00
-	x = 30 seconds	9.00 - 5.00
-	x = 1 minute	... to 9.00

*After 9 minutes and 0 seconds ('9.00') the word '.min' appears above the display and the minutes will be added behind the dot.*



### Tip

You can press and hold the + or - button to set the desired cooking time quicker.

### Switching on and off the beep

1. Press the on/off button on the far left twice.
2. Press and hold the << button and the + button simultaneously until you hear a beep.

*The beep is now switched off for all button operations, except for the pause button and the child lock button. Note: the kitchen timer alarm and the beep for error messages cannot be switched off.*

3. Use the same button combination to switch the sound back on.

### Automatic cooking programs

Your hob is fitted with 6 automatic cooking programs. You can set any end time of an automatic cooking program with the aid of the kitchen timer function (refer to page 21). The cooking programs are based on regular quantities. The tables are meant as a guideline, because of the large margins you can alter the dish according to your wishes.

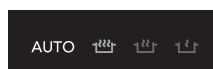

#### **To set an automatic program**

*The cooking zone is switched on.*

- Press the menu button.  
*A series of 6 icons will light up, one of which brighter than the others.*
- Again press the menu button, or press and hold down the menu button to go to the next menu functions.  
*The selected cooking programme automatically starts after 3 seconds. An 'A' for 'automatic' appears in the display.*

If an automatic cooking program is active, you can use the following buttons to go back to the manual cooking process:

<<, +, -, >> .



#### **Attention**

**The automatic cooking programs cannot be used if the adaptive zones are bridged.**

## OPERATION



### Boiling function\*

This function brings the content of the pan to a boil (100 °C) and keeps it boiling. A beep can be heard when the content is cooking or if the food has to be added. This function works only with the lid on the pan.

Dish	Number of people	Quantity	Pan	Zone	Fill the pan up to: (start the cooking process)
Cooked potatoes	1 - 3	200 - 500 g	Saucepan (Ø 200)	Ø 145	1,0 l incl. potatoes
	3 - 5	500 - 800 g	Low pan (Ø 200)	Ø 180	1,5 l incl. potatoes
	3 - 5	500 - 800 g	High pan (Ø 200)	Ø 180	1,5 l incl. potatoes
	6 - 8	1000 - 1400 g	High pan (Ø 200)	Ø 210 / adaptive	2,5 l incl. potatoes
	9 - 15	1500 - 2200 g	Large pan (Ø 240)	Ø 260	3,5 l incl. potatoes
	9 - 15	1500 - 2200 g	Large pan (Ø 240)	Ø 260 double	3,5 l incl. potatoes
Cooked (hard) vegetables	1 - 3	150 - 250 g	Saucepan (Ø 200)	Ø 145	1,0 l incl. vegetables
	3 - 4	300 - 500 g	Low pan (Ø 200)	Ø 180	1,5 l incl. vegetables
	3 - 4	300 - 500 g	High pan (Ø 200)	Ø 180	1,5 l incl. vegetables
	4 - 6	500 - 750 g	High pan (Ø 200)	Ø 210 / adaptive	2,5 l incl. vegetables
	6 - 8	750 - 900 g	Large pan (Ø 240)	Ø 260	3,5 l incl. vegetables
	6 - 8	750 - 900 g	Large pan (Ø 240)	Ø 260 double	3,5 l incl. vegetables
Eggs	2 - 6	2 - 6 eggs	Saucepan (Ø 200)	Ø 145	1,0 l incl. eggs
	8 - 12	8 - 12 eggs	Low pan (Ø 200)	Ø 180	1,5 l incl. eggs
Rice	1	100 g	Saucepan (Ø 200)	Ø 145	1,0 l only water <sup>1)</sup>
	2 - 4	200 - 400 g	Low pan (Ø 200)	Ø 180	1,5 l only water <sup>1)</sup>
	2 - 4	200 - 400 g	High pan (Ø 200)	Ø 180	1,5 l only water <sup>1)</sup>
	4 - 5	400 - 500 g	High pan (Ø 240)	Ø 210 / adaptive	2,0 l only water <sup>1)</sup>
Pasta	1 - 2	100 - 200 g	Low pan (Ø 200)	Ø 180	1,0 l only water <sup>1)</sup>
	2 - 3	200 - 300 g	High pan (Ø 200)	Ø 210 / adaptive	2,0 l only water <sup>1)</sup>
	4 - 6	400 - 600 g	Large pan (Ø 240)	Ø 260	3,0 l only water <sup>1)</sup>
	4 - 6	400 - 600 g	Large pan (Ø 240)	Ø 260 double	3,5 l only water <sup>1)</sup>

1) After the beep the rice or pasta can be added.

\* These menu functions work best if they are started at the beginning of the cooking process.

## OPERATION



### Simmering function

The temperature of the dish is constantly kept near the boiling point (90 °C - 95 °C). The simmer setting works best with a lid on the pan. Thicker dishes have to be stirred every 15 minutes. The maximum simmering time is 8 hours, unless a shorter time has been set with the aid of a timer.

Dish	Quantity +/-	Pan	Zone
Sauce or soup	1 l	Low pan (Ø 200)	Ø 145
	1 l	Low pan (Ø 200)	Ø 180
	1,5 l	High pan (Ø 200)	Ø 180
	1 l	Low pan (Ø 200)	Ø 210 / adaptive
	1,5 l	High pan (Ø 200)	Ø 210 / adaptive
	2,5 l	Large pan (Ø 240)	Ø 260
	2,5 l	Large pan (Ø 240)	Ø 260 double



### Function for keeping warm

The temperature of a dish is automatically kept at a constant temperature of 70 °C - 75 °C. The setting for keeping warm works best with a lid on the pan. Larger quantities and thicker dishes need to be stirred occasionally. The maximum time for keeping warm is 8 hours, unless a shorter time has been set with the aid of a timer.

Dish	Number of people	Quantity +/-	Pan	Zone
All dishes	1	1000 g	Saucepan (Ø 200)	Ø 145
	2 - 3	1500 g	Low pan (Ø 200)	Ø 180
	4	2000 g	High pan (Ø 200)	Ø 180
	4	2000 g	High pan (Ø 200)	Ø 210 / adaptive
	8	4000 g	Large pan (Ø 240)	Ø 260
	8	4000 g	Large pan (Ø 240)	Ø 260 double

## OPERATION

### wok

#### Wok function\*

The wok setting provides an optimal wok temperature, for both the oil and the wok. After the beep the pan has reached its temperature, the oil can be put in the pan and then the dish.

Dish	Number of people	Maximum amount of meat or fish / vegetables	Pan	Zone
Meat, fish, vegetables	1 - 2	300 g / 300 g	Wokpan	Ø 145
	1 - 2	300 g / 300 g	Wokpan	Ø 180
	3 - 4	600 g / 600 g	Wokpan	Ø 210 / adaptive
	3 - 4	600 g / 600 g	Wokpan	Ø 260
	1 - 2	300 g / 300 g	Wokpan	Ø 260 double



#### Searing function\*

The searing setting provides the optimal searing temperature. After the beep the pan has reached its temperature. The oil or butter can be put into the pan and then the dish.

Dish	Number of people	Quantity	Pan	Zone
Meat, fish	1 - 2	150 - 200 g	Frying pan	Ø 145
	2 - 3	200 - 400 g	Frying pan	Ø 180
	4 - 5	400 - 500 g	Frying pan	Ø 210 / adaptive
	5 - 6	500 - 600 g	Frying pan	Ø 260
	5 - 6	500 - 600 g	Frying pan	Ø 260 double

\* These menu functions work best if they are started at the beginning of the cooking process.

## OPERATION



### Grill function\*

The grill setting provides the optimal grilling temperature. A beep can be heard when the pan has reached its temperature.

Dish	Number of people	Quantity	Pan	Zone
Meat, fish, vegetables	1 - 2	100 - 200 g	Grill pan / plate	Ø 145
	2 - 3	200 - 300 g	Grill pan / plate	Ø 180
	3 - 4	300 - 400 g	Grill pan / plate	Ø 210 / adaptive
	4 - 6	400 - 600 g	Grill pan / plate	Ø 260
	4 - 6	400 - 600 g	Grill pan / plate	Ø 260 double

### Healthy cooking

#### Burning point of different types of oil

To ensure your food is fried as healthily as possible, Asko recommends choosing the type of oil according to the frying temperature. Each oil has a different burning point at which toxic gasses are released. The below table shows the burning points for various types of oil.

Oil	Smoke point °C
Extra virgin olive oil	160 °C
Butter	177 °C
Coconut oil	177 °C
Canola oil	204 °C
Virgin olive oil	216 °C
Sunflower oil	227 °C
Corn oil	232 °C
Peanut oil	232 °C
Rice oil	255 °C
Olive oil	242 °C

\* These menu functions work best if they are started at the beginning of the cooking process.

## OPERATION

### Cooking settings

Because the settings depend on the quantity and composition of the contents of the pan, the table below is intended as a guideline only.

#### **Use setting 'boost' and setting 12 to:**

- bring the food or liquid to the boil quickly;
- 'shrink' greens;
- heat oil and fat;
- bring a pressure cooker up to pressure.

#### **Use setting 11 to:**

- sear meats;
- fry flatfish;
- fry omelettes;
- fry boiled potatoes;
- deep fry foods.

#### **Use setting 10 to:**

- fry thick pancakes;
- fry thick slices of breaded meat;
- fry bacon (fat);
- fry raw potatoes;
- make French toast;
- fry breaded fish.

#### **Use setting 8 and 0 to:**

- complete the cooking of large quantities;
- defrost hard vegetables;
- fry thin slices of breaded meat.

#### **Use settings 1-7 to:**

- simmer bouillon;
- stew meats;
- simmer vegetables;
- melting chocolate;
- melting cheese.

### Cleaning

#### **Tip**

Set the child lock before you start cleaning the hob.

#### **Daily cleaning**

- Although food spills cannot burn into the glass, we nevertheless recommend you to clean the hob immediately after use.
- Best for daily cleaning is a damp cloth with a mild cleaning agent.
- Dry with kitchen paper or a dry tea cloth.

#### **Stubborn stains**

- Stubborn stains can also be removed with a mild cleaning agent such as washing-up liquid.
- Remove water marks and lime scale with vinegar.
- Metal marks (caused by sliding pans) can be difficult to remove. Special agents are available.
- Use a glass scraper to remove food spills. Melted plastic and sugar is also best removed with a glass scraper.

#### **Never use**

- Never use abrasives. They leave scratches in which dirt and lime scale can accumulate.
- Never use anything sharp such as steel wool or scourers.



## TROUBLESHOOTING

### *General*

If you notice a crack in the glass top (however small), switch the hob off immediately, unplug the hob, turn off the (automatic) fuse switch(es) in the meter cupboard or, in the event of a permanent connection, set the switch in the power supply lead to zero.) Contact the service department.

### *Troubleshooting table*

If the appliance does not work properly, this does not always mean that it is defective. Try to deal with the problem yourself first by checking the points mentioned below.

Symptom	Possible cause	Solution
The display lights up when the hob is activated for the first time.	This is the standard set-up routine.	Normal operation.
The fan runs on for several minutes after the hob has been switched off.	The hob is cooling.	Normal operation.
A slight smell is noticeable the first few times the hob is used.	The new appliance is heating up.	This is normal and will disappear once it has been used a few times. Ventilate the kitchen.
You can hear a ticking sound in your hob.	This is caused by the capacity limiter on the front and back zones. Ticking can also occur at lower settings.	Normal operation.
The pans make a noise while cooking.	This is caused by the energy flowing from the hob to the saucepan.	At high settings this is perfectly normal for some pans. It will not damage either the pans or the hob.
You have switched on a cooking zone, but the display keeps flashing.	The pan you are using is not suitable for induction cooking, or has a diameter of less than 12 cm.	Use a suitable pan, see page 12 and 13.
A cooking zone suddenly stops working and you hear a signal.	The preset time has ended.	Switch the bleep off by pressing the + or - button of the timer.

## TROUBLESHOOTING

Symptom	Possible cause	Solution
The hob is not working and nothing appears in the display.	There is no power supply due to a defective cable or a faulty connection.	Check the fuses or the electric switch (if there is no plug).
A fuse blows as soon as the hob is switched on.	The hob has been wrongly connected.	Check the electrical connections.
'br' appears in the display and the touch controls are not working.	The bridge function is activated.	Deactivate the bridge function (see pagina 16).
Error code F00.	The control panel is dirty or has water lying on it.	Clean the control panel.
Error code F0 up to and including F6 and FC.	Defective generator.	Contact the service department.
Error code F7.	The ambient temperature is not good.	Switch off all heat sources in the vicinity of the cooking plate.
Error code F8 and F08.	Appliance over heated.	The appliance has been switched off because of over heating. Let the appliance cool down and start again on a lower setting.
Error code F9 and/or continuous beep.	The appliance has been connected incorrectly and/or the mains voltage is too high.	Let your connection be changed.
Error code F99.	You have pressed two or more buttons at the same time.	Do not operate more than one button at the same time.
Error code FA.	Mains voltage is too low.	Contact your energy supplier.
Error code FAN.	Air circulation not good.	Make sure the venting holes under the cooking plate are open.
Other error codes.	Defective generator.	Contact the service department.

## *What you need to consider*

### **Safety instructions for the installation**

- The connection must comply with national and local regulations.
- The appliance must always be earthed.
- This appliance must be connected by a qualified person and comply with the local AS/NZS regulations.
- For the connection, use an approved cable (for example type HO7RR) in accordance with the regulations. The cable casing should be of rubber.
- The connection cable must hang freely and is not to be fed through a drawer.
- If you want to make a fixed connection, make sure that a multi-polar switch with a contact separation of at least 3 mm is fitted in the supply line.
- The worktop the hob is built into must be flat.
- The walls and the worktop surrounding the appliance must be heat resistant up to at least 85 °C. Even though the appliance itself does not get hot, the heat of the hot pan could discolour or deform the wall.
- Damage caused by incorrect connection, installation or use, will not be covered by the Manufacturer Warranty.
- The wall socket and plug must be accessible at all times.
- Ensure that the power cord will not come in contact with parts that can become hot.
- Do not use an adapter or an extension lead to connect the device to the electrical mains. Safe use of the device cannot be guaranteed with these accessories.
- Installation, maintenance or repairs should only be carried out by professionals who are authorized by the manufacturer, as failure to do so will void the warranty.
- Disconnect the electricity from the appliance before starting any repair work. Preferably unplug the appliance, switch the (automatic) fuse(s) off or, in the event of a permanent connection, set the switch in the power supply lead to zero.

## INSTALLATION

- Faulty parts may only be replaced by original Asko parts. Only those parts are guaranteed by Asko to meet the safety requirements.
- If the connecting cable is damaged, it may only be replaced by the manufacturer, the manufacturer's service organisation or equivalently qualified persons, in order to avoid dangerous situations.

### Clearance

Sufficient all-round clearance is essential to the safe use of the hob. Check that there is enough clearance.

\* HI1683g: min. 65 cm

HI1983g: min. 90 cm

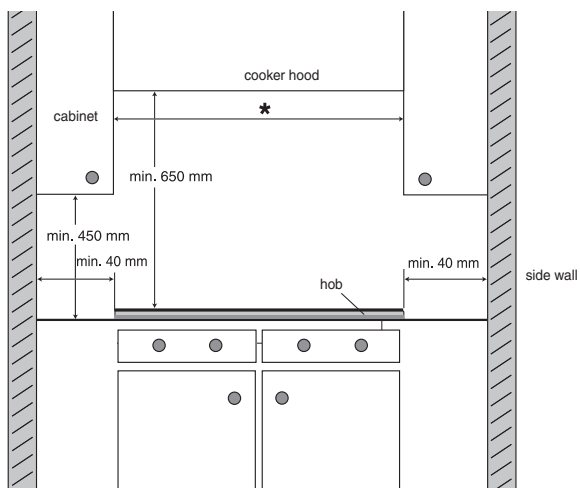

# INSTALLATION

## Installation dimensions

The dimensions and recesses are shown in the illustrations beneath.

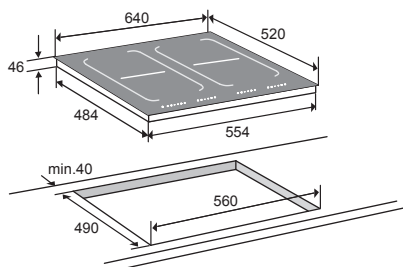

**Hi1683g**

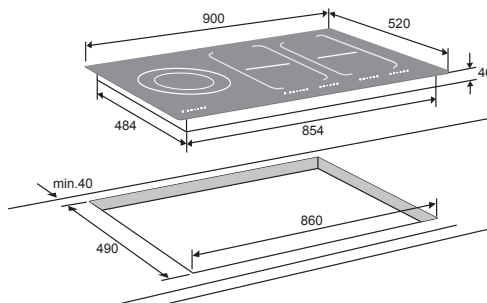

**Hi1983g**

If the hob is wider than the cupboard, with a worktop less than 46 mm thick, saw a cut-out in both sides of the cupboard, so the appliance is detached from the cupboard.

*Installation dimensions  
inside the cabinet*  
 $x < 46 \text{ mm}: y = 46 \text{ mm} - x$   
 $x \geq 46 \text{ mm}: y = 0 \text{ mm}$

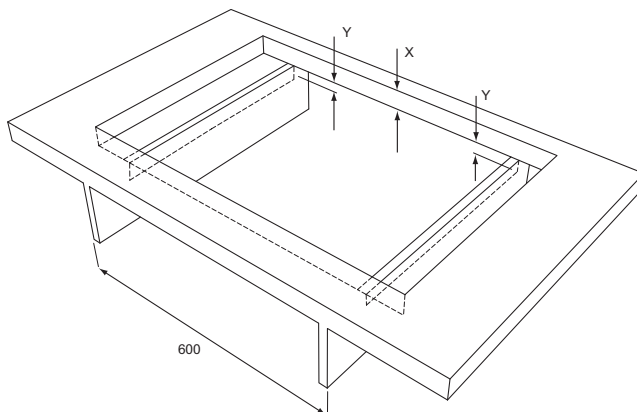

# INSTALLATION

## Ventilation

The electronics in the appliance need cooling. The appliance will automatically switch off if there is insufficient air circulation. There are ventilation openings on the underside of the appliance. It must be possible for cool air to be drawn in through these openings. Air vents are located at the front of the appliance.

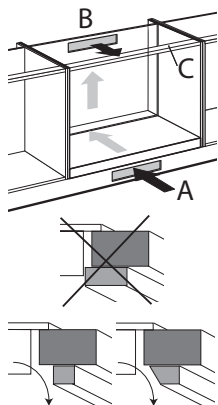

## Constructing above a load or an oven or fixed panel

Ventilation occurs through the plinth (A) and the back of the cupboard (B). Saw out the ventilation openings (min. 100 cm<sup>2</sup>). Air supply A is not necessary if there is another opening that can supply air together with opening B.

Make sure the crossbar does not impede the airflow. Plane or saw the crossbar C diagonally if necessary.

## It is important to ensure adequate ventilation (intake and outlet).

- Create a ventilation opening at the front of the kitchen unit.  
The opening must be at least as wide as the appliance itself and must be at least 3 mm high, if the appliance is being installed above a drawer or a shelf. Ensure a clearance of at least 20 mm between the hob and drawer or shelf 'D'.
- If creating a ventilation opening is impossible, ensure that there is a gap of at least 60 mm between the hob and the drawer or shelf.

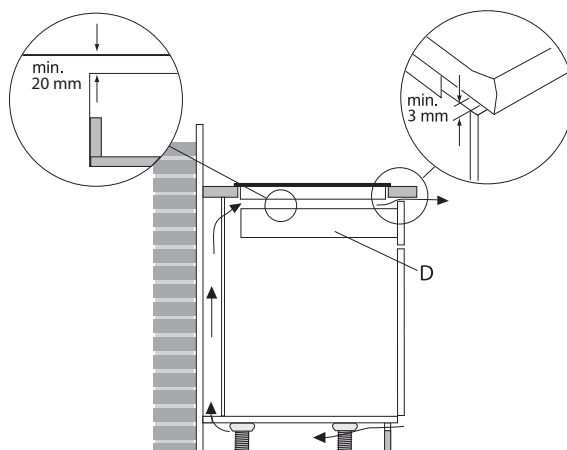

# INSTALLATION

## Electrical connection

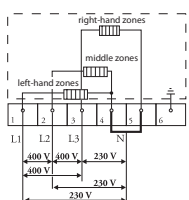
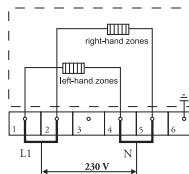
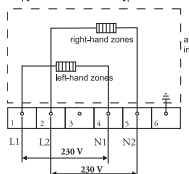
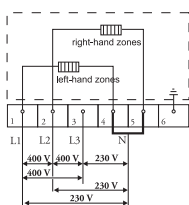

### Common connections:

- 3 phases with 1 neutral connection (3 1N, 400 V ~ / 50 Hz):
  - ▷ The voltage between the phases and the neutral is 230 V ~. The voltage between the phases is 400 V ~. Fit a connecting bridge between connecting points 4-5. Phase 3 carries no load. The groups must have fuses of at least 16 A (3x). The core diameter of the connecting cable must be at least 2.5 mm<sup>2</sup>.
- 2 phase and 2 neutral connection (2 2N, 230 V ~ / 50 Hz):
  - ▷ The voltage between the phases and the neutrals is 230 V ~.
  - ▷ The group must have fuses of at least 16 A (2x). The core diameter of the connecting cable must be at least 2.5 mm<sup>2</sup>.

### Special connections:

- Single phase connection (1 1N, 230 V ~ / 50 Hz):
  - ▷ The voltage between the phase and the neutral is 230 V ~. Fit a connecting bridge between connecting points 1-2 and 4-5. The group must have a fuse of at least 32 A. The core diameter of the connecting should be at least 6 mm<sup>2</sup>.

### Connection for hob Hi1983g:

- 3 phases with 1 neutral connection (3 1N, 400 V ~ / 50 Hz):
  - ▷ The voltage between the phases and the neutral is 230 V ~.
  - ▷ The voltage between the phases is 400 V ~. Fit a connecting bridge between connecting points 4-5. The groups must have fuses of at least 16 A (3x). The core diameter of the connecting cable must be at least 2.5 mm<sup>2</sup>.

The bridges on the connecting block can be used to create the required connections, as indicated in these illustrations.

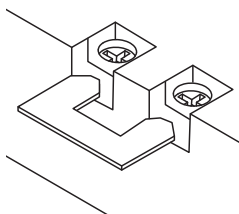

Fix the cable with a pull relief and close the cover.

Connecting point, wall-mounting socket and plug must be accessible at all times.

## INSTALLATION

### Building in

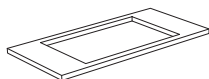

Check that the cabinet and the cut-out meet the dimension and ventilation requirement

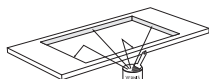

Treat the sawn ends of wooden or synthetic worktops with sealing varnish if necessary, to prevent moisture causing the worktop to swell.

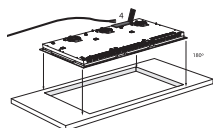

Lay the hob upside down on the worktop.

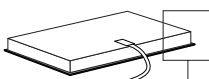

Fit the connecting cable to the appliance in compliance with the requirements (see page 36).

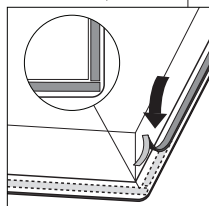

Remove the protective layer from the sealing tape and apply the tape in the groove of the aluminium profile or on the edge of the glass plate. Do not stick tape round the corners, but cut 4 separate pieces to seal the corners well.

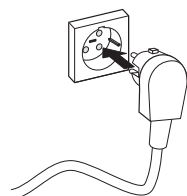

Turn the hob over and lay it in the recess.

Connect the appliance to the mains. A short bleep will be heard and all the displays will light up briefly. The appliance is ready for use.

Check that it works properly. If the appliance has been wrongly connected either a bleep will sound or nothing will appear in the displays, depending on the error.

# INSTALLATION

## *Technical details*

This appliance complies with all relevant CE directives.

<b>Hob type</b>	<b>Hi1683g</b>	<b>Hi1983g</b>
Induction	x	x
Connection	230V - 50Hz	230V - 50Hz
Phases	2	3
<b>Maximum capacity cooking zones</b>		
Middle left		5,5 kW (Ø260)
Front left	3,7 kW (180x220)	3,7 kW (180x220)
Rear left	3,7 kW (180x220)	3,7 kW (180x220)
Rear right	3,7 kW (180x220)	3,7 kW (180x220)
Front right	3,7 kW (180x220)	3,7 kW (180x220)
<b>Connected load</b>		
L1	3,7 kW	3,7 kW
L2	3,7 kW	3,7 kW
L3		3,7 kW
Total connected load	7400 W	11000 W
<b>(Building in) dimensions</b>		
Appliance width x depth	640 x 520 mm	900 x 520 mm
Build-in height from top of worktop	43 mm	43 mm
Cut-out width x depth	560 x 490 mm	860 x 490 mm
Minimal distance cut-out to back wall	40 mm	40 mm
Minimal distance cut-out to side wall	40 mm	40 mm

## ENVIRONMENTAL ASPECTS

### Disposal of packaging and appliance

In the manufacturing of this appliance durable materials were used. Make sure to dispose of this equipment responsibly at the end of its lifecycle. Ask the authorities for more information regarding this.

The appliance packaging is recyclable. The following may have been used:

- cardboard;
- polythene film (PE);
- CFC-free polystyrene (PS hard foam).

Dispose of these materials in a responsible manner and in accordance with government regulations.



As a reminder of the need to dispose of household appliances separately, the product is marked with the symbol of a crossed-out wheeled dustbin. This means that at the end of its working life, the product must not be disposed of as urban waste. It must be taken to a special local authority differentiated waste collection centre or to a dealer providing this service.

Disposing of a household appliance separately avoids possible negative consequences for the environment and health deriving from inappropriate disposal and enables the constituent materials to be recovered to obtain significant savings in energy and resources.



### **Declaration of conformity**

We declare that our products meet the applicable European Directives, Decisions and Regulations and the requirements listed in the standards referenced.

