

DIGITAL CAMERA

DC128 Optical Zoom Camera User Manual

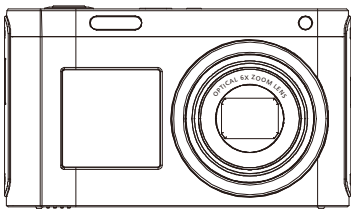

- To ensure proper use of this product, please read this user manual carefully before use.
- Please keep this manual in a safe place for future reference.

Catalogue

DIGITAL CAMERA	1
Pre-Usage Instructions	2
Camera Functions	3
1. Button Icons	3
2. Indicator light description	4
3. Button Function Descriptions	5
4. Photo preview screen	6
5. Photo mode quick settings	7
6. Video Preview Screen	8
7. Video Mode Quick Settings	9
8. Playback Preview Screen	9
Camera settings	10
1. Photo Settings	10
2. Video Settings	11
3. System Settings	12
4. Playback Settings	13
App usage	14
1. Download the App	14
2. Wi-Fi connection	14
Connect & Charge	15
1. Battery Charging	15
2. Connect to Computer	16

Pre-Usage Instructions

1. Thank you for choosing this product. Please read the following instructions for better use.
2. This product is a 12X optical zoom HD digital camera.
3. Wi-Fi name: DC128-xxxxxxx, initial password: 12345678.
4. Supports up to 256GB TF card. For optimal performance, use a U3 high-speed card (read speed 100MB/s, write speed 60MB/s or above).
5. The images in this manual are for reference only; please refer to the actual functionality.

Camera Functions

1. Button Icons

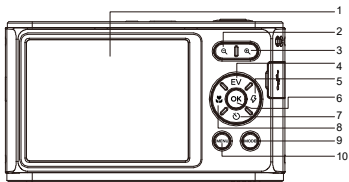

- | | |
|----------------------------------|------------------------|
| 1. Display Screen | 6. Confirm Button |
| 2. Zoom Out Button | 7. Down/Timer Shortcut |
| 3. Zoom In Button | 8. Left/Macro shortcut |
| 4. Up/EV Function Shortcut | 9. Mode Button |
| 5. Right/LED Fill Light Shortcut | 10. Menu Button |

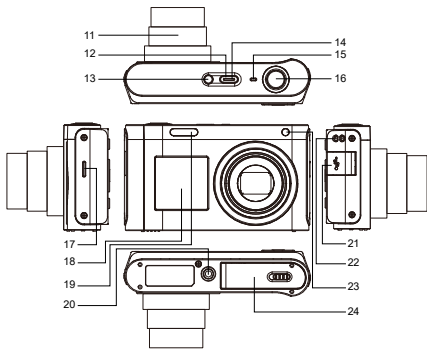

- | | |
|---------------------------|---------------------------|
| 11. Optical Zoom Lens | 18. Front Display Screen |
| 12. Power Button | 19. Flash |
| 13. Switch Screens Button | 20. Tripod Mount Hole |
| 14. Indicator Light | 21. TYPE-C Port |
| 15. Microphone(MIC) | 22. Buckle |
| 16. Shutter Button | 23. Focus Assist Light |
| 17. Horn | 24. Battery/ TF Card Solt |

2. Indicator light description

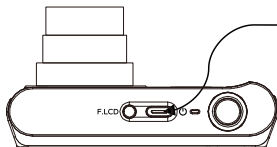

- 【 Green indicator Light】**
When the camera starts, the green light is steady on
- 【 Red indicator Light】**
When charging the camera battery, the red light is steady on. When the battery is fully charged, the red light will go off.

3. Button Function Descriptions

Buttons	Function Descriptions
Power Button	<ol style="list-style-type: none">1. In the powered-off state, a short press will turn the camera on;2. In the powered-on state, a short press will turn the camera off.
Shutter Button	<ol style="list-style-type: none">1. In photo mode, press and hold the shutter button to focus, then press again to take the photo once the focus box turns green.2. In video mode, press to start or stop recording.
Zoom out button	<ol style="list-style-type: none">1. After zooming in with the [⊕] key in preview mode, press the [⊖] key to zoom out.2. In MF mode, adjust the focus manually.3. In playback mode, zoom out the image.
Zoom in button	<ol style="list-style-type: none">1. In preview mode, press the [⊕] key to zoom in on the image.2. In MF mode, manually adjust the focus.3. In playback mode, zoom in on the image.
EV function shortcut key	<ol style="list-style-type: none">1. In preview mode, press this key to quickly access the EV adjustment menu.2. In menu settings and other interfaces, it functions as the scroll-up key.3. While recording, press this key to pause or resume recording.
Timer photo shortcut key	<ol style="list-style-type: none">1. In preview mode, press this key to quickly open the timer photo selection menu.2. In menu settings and other interfaces, it functions as the scroll-down key.
Macro shortcut key	<ol style="list-style-type: none">1. In preview mode, press this key to quickly open the focus mode options menu, offering 4 options: Macro (Auto), Macro (Manual), AF (Auto Focus), and MF (Manual Focus).2. In menu settings and playback mode, it functions as the scroll-left key.
Fill light shortcut key	<ol style="list-style-type: none">1. In preview mode, press this key to quickly open the flash mode options menu, offering 3 choices: Forced Flash, Auto Flash, and Forced Off.2. In recording mode, press this key to quickly turn on the fill light, which will stay on until pressed again to turn it off.3. In settings and playback mode, it functions as the scroll-right key.
OK button	<ol style="list-style-type: none">1. In the menu settings, used to confirm selections.2. In the preview mode, press the [OK] key to bring up the quick settings menu.
Menu button	In any mode, press the [MENU] button briefly to enter the settings menu.
Mode button	Mode switch: In preview mode, a short press cycles through photo mode, video mode, and playback mode.

4. Photo preview screen



Icon	Explanation
	This icon shows the current photo shooting scene setting.
[xxxxx]	This icon displays the number of photos that can be stored on the current memory card, decreasing as photos are taken.
	This icon shows the current photo resolution setting.
	This icon shows the photo quality setting for shooting.
	This icon shows the current metering mode setting.
	This icon shows the current filter mode setting.
	This icon shows the current white balance setting.
	This icon shows whether the current setting is for single-shot or continuous shooting.
ISO AUTO	This icon shows the current ISO setting.
	This icon shows the current battery level.
	TF card status: There are 2 possible states—either the card is inserted or not inserted.
	Timer photo status: Opened through the timer photo shortcut key, offering 4 options: Off, 2 seconds, 5 seconds, and 10 seconds. The default is Off.
AF	Focus status: Opened through the macro shortcut key, offering 4 options: Macro (Auto), Macro (Manual), AF (Auto Focus), and MF (Manual Focus).
	Flash status: In photo mode, opened through the flash shortcut key, offering 3 options: Auto, Forced Flash, and No Forced Flash. The default is No Forced Flash.
+0	EV value status: Opened through the EV shortcut key, offering a range from -2 to +2, with the default set to +0.0.

5. Photo mode quick settings

In the photo preview screen, press the [OK] key to bring up the photo quick settings menu, as shown below:



Use the up/down keys to select items, press the right key to enter the submenu, and use the up/down keys to choose submenu options. Press the left or right keys to exit the submenu and return to the item options. Press [OK] to exit quick settings and return to preview mode.

Option	Explanation
Resolution	Allows you to set the photo pixel resolution.
Scene selection	Set the photo scene, offering 11 options: Auto, scenery, Portrait, Sport, Night Portrait, Night Scenery, Party, Sun Set, Back Light, Fireworks, and Beauty.
Image quality	Set the image quality of the photos, offering 3 options: Super Fine, Fine, and Normal, with the default set to Fine.
Filter Mode	Set the photo filter effects, offering 11 options: Standard, Color Enhancement (Red), Color Enhancement (Green), Color Enhancement (Blue), Color Enhancement (Orange), Color Enhancement (Yellow), Color Enhancement (Purple), Sepia, Monochrome, Pen, and Vivid.
AWB	Set the white balance, offering 5 options: Auto, Daylight, Cloudy, Tungsten, and Fluorescent, with the default set to Auto.
ISO sensitivity	Set the ISO (sensitivity), offering 7 options: Auto, ISO 100, ISO 200, ISO 400, ISO 800, and ISO 1600, with the default set to Auto.
Metering	Offers 3 options: Multi (Average Metering), Center, and Spot, with the default set to Center. Different metering modes result in varying photo brightness. For example, when photographing the moon at night, Spot Auto Metering is recommended.
Burst Mode	Offers 2 options: Burst Mode and Single. With Burst Mode, pressing the shutter will quickly capture 3 photos.

6. Video Preview Screen

In photo mode, press the [MODE] button to enter video mode. The video mode screen is shown below:

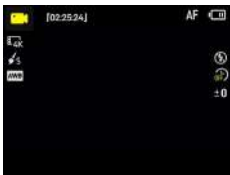

Icon	Explanation
	This icon indicates that the device is in video recording mode.
[xx:xx:xx]	This shows the remaining recording time on the memory card.
	This shows the current video resolution setting.
	This shows the current filter mode setting.
	This shows the current white balance setting.
	This shows the current battery level.
	This shows the current focus mode setting.
	Fill light status: In video mode, press the fill light shortcut key to turn the fill light on or off. Two options are available: On and Off, with the default set to Off.
	This shows the current time-lapse recording status.
	This shows the current EV value.

7. Video Mode Quick Settings

In the video preview screen, press the [OK] key to bring up the video quick settings menu, as shown below:

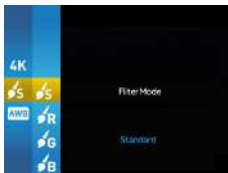

Use the up/down keys to select items, then press the right key to enter the submenu. Use the up/down keys to choose submenu options. After entering the submenu, press the left/right keys to exit back to the item options. Press [OK] to exit quick settings and return to preview mode.

Option	Explanation
Resolution	Set different video resolutions.
Filter mode	Set the photo filter effects, offering 11 options: Standard, Color Enhancement (Red), Color Enhancement (Green), Color Enhancement (Blue), Color Enhancement (Orange), Color Enhancement (Yellow), Color Enhancement (Purple), Sepia, Monochrome, Pen, and Vivid.
AWB	Set the white balance, offering 5 options: Auto, Daylight, Cloudy, Tungsten, and Fluorescent, with the default set to Auto.

8. Playback Preview Screen

In video mode, press the [MODE] button to enter playback mode. After entering playback mode, you can perform the following actions:

1. In playback mode, use the left/right keys to browse through the photos and videos taken.
2. Press the zoom-out button to enter the 9-grid thumbnail preview, and press the zoom-in button to enlarge the photo. Use the up/down/left/right keys to move the photo.
3. In full-screen preview, press the up key to rotate the photo.

Camera settings

1. Photo Settings

In the photo mode preview screen, press the [MENU] button to enter the photo menu settings, as shown below:



Sharpness	Select this item, then press the right key to choose the photo sharpness. Three options are available: Normal, Sharp, and Soft, with the default set to Normal.
Anti-shake	Select this item, press right to choose anti-shake: On or Off (default: Off). If anti-shake is on, use the flash in low light to avoid noise.
Date Stamp	Select this item, press right to enable or disable the date watermark (On/Off, default: Off). If On, the current date and time will appear in the bottom-right corner of the photo. Ensure the correct time is set in system settings or via Wi-Fi to avoid incorrect timestamps.
Quick Review	Select this item, press right to set the photo preview duration after capture: Off, 2 seconds, or 5 seconds (default: Off).

2. Video Settings

In the video mode preview screen, press the [MENU] button to enter the video menu settings, as shown below:



Metering	Select this item, then press the right key to set the camera's metering mode. Offers 3 options: Multi (Average Metering), Center, and Spot, with the default set to Center.
Date label	Select this item, press right to enable or disable the date watermark (On/Off, default: Off). If On, the current date and time will appear in the bottom-right corner of the photo. Ensure the correct time is set in system settings or via Wi-Fi to avoid incorrect timestamps.
Time-lapse video	Select this item, press right to choose time-lapse recording options: Off, 1 second, 3 seconds, or 5 seconds (default: Off).
recording sensitivity	Select this item, press right to set microphone sensitivity: Strong, Soft, or Normal (default: Strong).

3. System Settings

In photo, video, or playback mode, press the [MENU] button to enter the menu settings, then press the right key to enter the system menu settings, as shown below:



Wi-Fi	Select this item, press right to enable the device's Wi-Fi hotspot for connection via the mobile app. If already connected, press [OK] to turn off the hotspot. If no connection is made within 2 minutes, the hotspot will automatically turn off.
Auto screen off	Select this item, press right to set the device's auto power-saving mode after inactivity. Options: Off, 3 minutes, 5 minutes, or 10 minutes (default: 3 minutes). The screen turns off, and the indicator light pulses.
Language	Select this item, press right to set the device's interface language. Multiple options are available, with the default set to English.
Frequency	Select this item, press right to choose the power frequency. Two options are available: 50Hz and 60Hz. Note: Select the appropriate frequency based on your region to avoid frequency stripes in the image.
LCD Brightness	Select this item, press right to set the display brightness. Three options are available: Normal, Strong, and Soft, with the default set to Normal.
Set date	Select this item, press right to manually set the date and time. When connected to the device's Wi-Fi hotspot, the phone's date and time will sync automatically, no manual setting required.
Format	Select this item, press right to format the TF card and follow the prompts. Note: Formatting erases all files, so back up important data beforehand.
Default	Select this item, press right to enter the factory reset screen and follow the prompts.
Version	Select this item, press right to view the current software version of the device.

4. Playback Settings

In the playback mode preview screen, press the [MENU] button to enter the playback menu settings, as shown below:



Protection	Used to lock a photo, preventing deletion. To delete, unlock it first. Press up/down to select, then press [OK] for options: Lock current, Unlock current, Lock all, Unlock all.
Delete	Used to delete photos and videos. Press up/down to select, then press [OK] to choose: Delete current photo or Delete all files.
Rotate	Used to set photo rotation. Press up/down to select, then press [OK] to choose: Off, 90°, 180°, or 270°.

App usage

1. Download the App

For iOS or Android phones, use your browser to scan the QR code below or the one displayed on the screen after enabling Wi-Fi to download the app.



For instructions on how to use the VD Cam app, refer to the in-app guide.

2. Wi-Fi connection

1. Keep the camera on.
2. Press [MENU] → Set → Wi-Fi → turn on hotspot.
3. On your phone, connect to SSID: DC128-xxxxxxx, password: 12345678.
4. Open the app and tap the camera icon.
5. Once connected, use the app to adjust settings, record, take photos, and view/download media.

- To ensure proper camera operation, do not modify the Wi-Fi name or password.
- The camera and phone should be within 10 meters of each other without walls in between.
- After the camera is connected to the phone, press [OK] to turn off the Wi-Fi hotspot.
- Other camera functions will be unavailable during Wi-Fi connection.
- If no connection is made within 2 minutes, the camera will automatically turn off the Wi-Fi hotspot.

Connect & Charge

1. Battery Charging

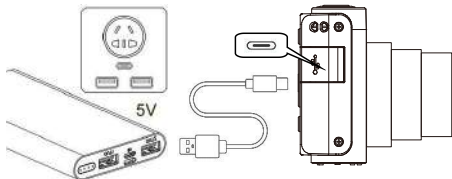

1. Connect the USB cable to the charging port on the side of the camera.
2. Connect the other end of the USB cable to a 5V/2A USB power adapter or power bank.
3. The camera indicator light will turn red while charging.
4. Once fully charged, the light will turn off. Charging takes approximately 2-3 hours.

Note:

* If the camera is not used for a long time, it is recommended to charge the battery every 3 months and then discharge it to maintain battery life.

2. Connect to Computer

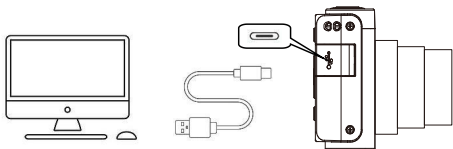

The camera can be used as an MSDC (Mass Storage Device Class) or a PC camera.

1. Keep the camera powered on.
2. Connect the camera to the computer using a USB cable.
3. The MSDC & PC Camera options will appear on the camera screen. Use the up and down buttons to select, then press the OK button to confirm.
4. Select MSDC for USB drive mode to download photos and videos to the computer; select PC for webcam mode to use the camera as a live-streaming webcam.

FCC Warning

This device complies with Part 15 of the FCC Rules. Operation is subject to the following two conditions:

(1) This device may not cause harmful interference, and (2) this device must accept any interference received, including interference that may cause undesired operation.

NOTE 1: This equipment has been tested and found to comply with the limits for a Class B digital device, pursuant to part 15 of the FCC Rules. These limits are designed to provide reasonable protection against harmful interference in a residential installation. This equipment generates, uses and can radiate radio frequency energy and, if not installed and used in accordance with the instructions, may cause harmful interference to radio communications. However, there is no guarantee that interference will not occur in a particular installation. If this equipment does cause harmful interference to radio or television reception, which can be determined by turning the equipment off and on, the user is encouraged to try to correct the interference by one or more of the following measures:

- Reorient or relocate the receiving antenna.
- Increase the separation between the equipment and receiver.
- Connect the equipment into an outlet on a circuit different from that to which the receiver is connected.
- Consult the dealer or an experienced radio/TV technician for help.

NOTE 2: Any changes or modifications to this unit not expressly approved by the party responsible for compliance could void the user's authority to operate the equipment.

The device has been evaluated to meet general RF exposure requirement. The device can be used in portable exposure condition without restriction.