

Use & Care MANUAL



Tuscany Hoods

TVWH360
TVWH480
TVWH660

Congratulations

Your purchase of a Tuscan hood attests to the importance you place upon the quality and performance of the major appliances you use. With minimal care, as outlined in this guide, your new hood is designed to provide you with years of reliable service. Please take a few minutes to learn about its proper and efficient use and care.

This guide will provide you with the information you need to become familiar with your hood's care and operation. Your complete satisfaction is our ultimate goal. If you have any questions or comments about this product, please contact the dealer from whom you purchased it, or contact our Consumer Support Center at 1-888-845-4641.

We appreciate your choosing a Viking Range, LLC product, and hope that you will again select our products for your other major appliance needs. For more information about the complete and growing selection of our products, visit us online at vikingrange.com

Table of Contents

Getting Started

| | |
|-------------------------|---|
| Before Using Hood _____ | 2 |
| Warnings _____ | 3 |

Product Controls/Operation

| | |
|------------------------------|---|
| Settings and Functions _____ | 4 |
| Hood Operation _____ | 4 |

Product Care

| | |
|--------------------------------|---|
| Cleaning and Maintenance _____ | 5 |
| Hood Canopy _____ | 5 |
| Enamel Finish _____ | 5 |
| Stainless Steel Finish _____ | 5 |
| Baffle Filters _____ | 6 |
| Light Bulbs _____ | 7 |
| Service Information _____ | 7 |
| Warranty _____ | 8 |

Before Using Your Hood

Although the hood is cleaned upon completion of the manufacturing process, you will probably need to clean your hood again after installation. Wipe the surface of the hood with a good household cleaner applied with a soft cloth, or stainless steel polish, depending on the finish of your hood. This will leave a protective finish on the hood.

Warnings

READ AND SAVE THESE INSTRUCTIONS

WARNING

To reduce the risk of fire, electric shock, or injury when using your unit, observe the following:

- Installation work and electrical wiring must be done by qualified person(s) in accordance with all applicable codes and standards, including fire-rated construction.
- Sufficient air is needed for proper combustion and exhausting of gases through the flue (chimney) of fuel burning equipment to prevent back drafting. Follow the heating equipment manufacturer's guideline and safety standards such as those published by the National Fire Protection Association (NFPA), and the American Society for Heating, Refrigeration and Air Conditioning Engineers (ASHRAE), and the local code authorities.
- When cutting or drilling into wall or ceiling, do not damage electrical wiring and other hidden utilities.
- Ducted fans must always be vented to the outdoors.
- **WARNING!:** To reduce the risk of fire, use only metal ductwork.
- **CAUTION!:** To reduce risk of fire and to properly exhaust air, be sure to duct air outside. Do not vent exhaust air into spaces within walls or ceilings, or into attics, crawl spaces, or garages.

WARNING

For general ventilating use only.

- **DO NOT use to exhaust hazardous or explosive materials and vapors.**
- **DO NOT flambe under the hood.**

WARNING

Accessible parts may become hot when used with cooking appliance.

- Children should be supervised to ensure that they do not play with the appliance.
- This appliance is not intended for use by persons (including children) with reduced physical sensory or mental capabilities, or lack of experience and knowledge, unless they have been given supervision or instruction concerning use of the appliance by a person responsible for their safety.

WARNING

Unplug power cords from control panel before cleaning or servicing hood.

WARNING

To reduce the risk of fire, electric shock, or injury to persons, observe the following:

- Use this unit only in the manner for which it is intended. If you have any questions, contact the manufacturer.
- Before servicing or cleaning unit, switch power off at service panel and lock service panel to prevent power from being switched on accidentally. When the service disconnecting means cannot be locked, securely fasten a prominent warning device, such as a tag, to the service panel.

WARNING

TO REDUCE THE RISK OF A RANGETOP GREASE FIRE:

1. Never leave surface units unattended at high setting. Boilovers cause smoking and greasy spillovers that may ignite. Heat oils slowly on low or medium settings.
2. Always turn hood ON when cooking at high heat or when cooking flaming foods. (i.e. Crepes suzette, Cherries jubilee, Peppercorn beef flambé).
3. Clean ventilating fans frequently. Grease should not be allowed to accumulate on fan or filter.
4. Use proper pan size. Always use cookware appropriate for the size of the surface element.

WARNING

TO REDUCE THE RISK OF FIRE, ELECTRICAL SHOCK, OR INJURY TO PERSONS, RANGEHOODS MUST BE INSTALLED WITH THE VENTILATORS THAT ARE SPECIFIED ON THEIR CARTON INDICATING SUITABILITY WITH THIS MODEL. OTHER VENTILATORS CANNOT BE SUBSTITUTED.

WARNING

DO NOT place flammable material on warming shelves when using heat lamps.

WARNING

If the power to the hood is not disconnected during cleaning, the heat sensor thermostat can cause the blower to turn on.

WARNING

Do not use a porcelain cleaner or rough abrasive cleaner.

⚠️ WARNING

To reduce the risk of injury to persons in the event of a rangetop grease fire, observe the following: (Based on "Kitchen Firesafety Tips," published by NFPA.)

1. SMOTHER FLAMES with a close fitted lid, cookie sheet, or metal tray, then turn off the burner. BE CAREFUL TO PREVENT BURNS. If the flames do not go out immediately, EVACUATE AND CALL THE FIRE DEPARTMENT.
2. NEVER PICK UP A FLAMING PAN. You may be burned.
3. DO NOT USE WATER, including wet dishcloths or towels a violent steam explosion will result.
4. Use an extinguisher ONLY if
 - You know it is a Class ABC extinguisher, and you already know how to operate it.
 - The fire is small and contained in the area where it started.
 - The fire department is being called.
 - You can fight the fire with your back to an

⚠️ CAUTION

This appliance is not to be used by persons (including children) with reduced physical, sensory or mental capabilities, or lack of experience and knowledge, unless they have been given supervision or instruction concerning the use of the appliance by a person responsible for their safety. Children should be supervised to ensure that they do not play with the appliance.

Settings and Functions

Hood Operation

Always turn on your hood before you begin cooking to establish airflow in the kitchen. Also let the blower run for a few minutes to clear the air after you turn off your cooking appliance. This will help keep the kitchen air cleaner.

ON/OFF - Blower speed knob—Starts and stops the blower. When turned on the blower will operate at the previous setting of the speed control. Push in on the knob to allow it to pop out. Turn the knob clockwise to increase the blower speed and counter clockwise to decrease speed. 0 is off, 1 is lowest speed, and 5 is the highest speed. The type of cooking you are doing will dictate the speed of the blower you use.

Light On/Off / Dimmer knob —Controls the 8-watt LED lights located in the front of the hood. Push in on the knob to allow it to pop out. Turn the knob clockwise to brighten the LED lights and counter clockwise to dim the lights.. 0 is off, 1 is dimmest and 5 is the brightest.

Heat lamp switches— Push to turn the heat lamps on and off.

Each professional 18" H. wall hood will be equipped with one or two heat lamp outlets. **The 250-watt infrared bulbs are not included and should be purchased locally.**

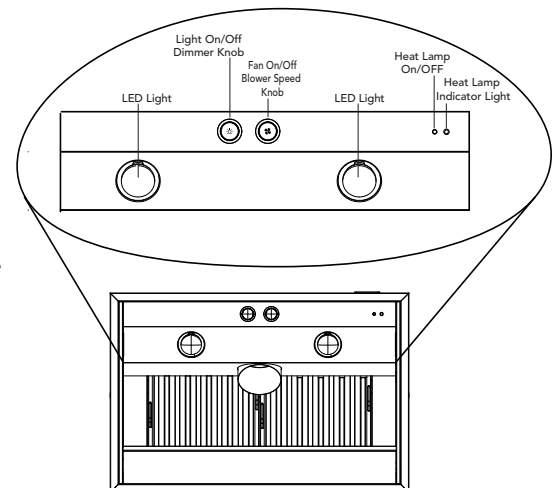

Cleaning and Maintenance

⚠ CAUTION

Unplug power cords from control panel before cleaning or servicing hood.

⚠ CAUTION

Do not use a porcelain cleaner or rough abrasive cleaner.

Any piece of equipment works better and lasts longer when maintained properly and kept clean. Ventilation equipment is no exception. Your hood must be kept clean and maintained properly.

Cleaning Hood Canopy

Finishes in enamel or stainless steel are highly resistant to damage or discoloration due to grease, steam, and heat—provided that reasonable care is given to the equipment. The following suggestions will help keep your hood looking new.

1. Do not allow an excessive accumulation of grease. For best results, you should wipe your hood clean with a cloth dipped in warm, soapy water. **DO NOT USE ABRASIVE CLEANSERS, STEEL WOOL PADS, OR ABRASIVE CLOTHS. DO NOT** use cleansers that contain chlorides; the chlorides in the cleaner could damage the stainless steel finish. If you need to scrape stainless steel to remove encrusted materials, first soak the area with hot towels to loosen the material, then use a wooden or nylon spatula or scraper. **DO NOT** use a metal knife, spatula, or any other metal tool to scrape stainless steel.
2. Every 3 months give your hood a thorough cleaning. On painted surfaces, use a new coat of wax. A good wax cleaner—available at either a grocery or hardware store—will do both jobs at once. On stainless steel surfaces, use a good stainless steel cleaner and polish.

Renewing Enamel Finish (Painted Models Only)

If discoloration occurs, you should thoroughly polish the finish on your hood to renew its gloss and luster and to remove any grease residue which may have a yellowing effect. Use any good enamel polish, refrigerator polish, or automotive polish.

Renewing Stainless Steel Finish

Regular cleaning is the best way to assure that your stainless steel finish stays bright and unscratched. Use lemon oil or stainless steel polish to coat and protect stainless steel.

Cleaning and Maintenance

Cleaning Baffle Filters

As air passes through a baffle filter, grease particles collect on the stainless steel U-shaped baffle channels and drip down into the bottom of the filter. Baffle filters are extremely efficient when compared to mesh filters. The power of the hood is increased as more air passes through a baffle filter than with mesh filters, which are usually dirty. Baffle filters are almost universally required in commercial installations due to their superior ability to capture grease. The baffle filters should be examined periodically to assure that all surfaces and parts are clean. The filters can be washed in a dishwasher or in a sink with hot, soapy water. Simple periodic cleaning will ensure maximum filter effectiveness.

- Do not use caustic detergent to clean the filters. An abrasive or corrosive cleaner may damage the finish.
- Do not take the baffle filters apart to clean them. It is not necessary and will void the filter warranty.

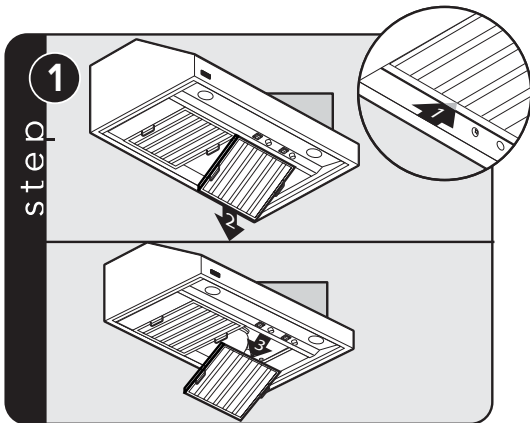

Slide filter forward off of rear lip. Lower filter rear, then slide filter front out.

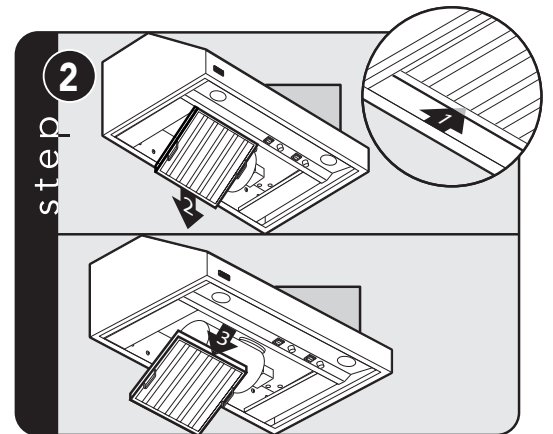

Slide filter forward off of rear lip. Lower filter rear, then slide filter front out.

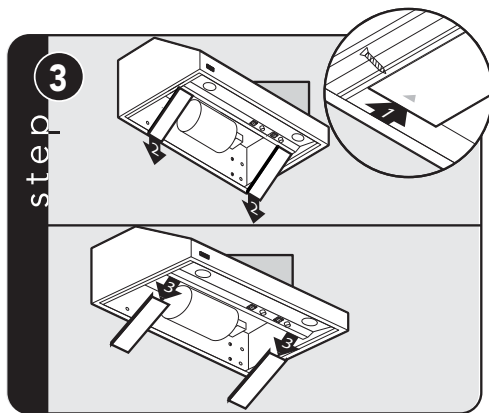

Remove the screws located on the side at the top and bottom of each spacer and slide spacer forward off of rear lip. Lower spacer rear, then slide spacer front out.

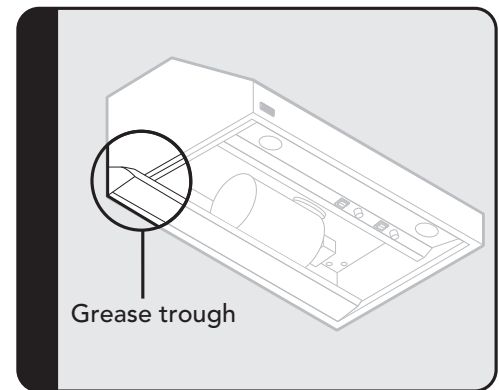

When cleaning filters, always remove the grease trough and clean by soaking in a sink with hot soapy water.

Replacing the Light Bulbs

When removing bulbs use an oven mitt to protect your hand in case the bulb breaks.

LED Lights

1. Unscrew bulb.
2. Replace the bulb with a 120 volt, Phillips R20 8-watt LED bulb (8R20/F90 2700 DIM). Can be purchased locally.

Infrared Heat Lamp

1. Unscrew infrared bulb from heat lamp socket.
2. Replace the bulb with an R40, 120 volt, 250-watt infrared bulb. (not included with product)

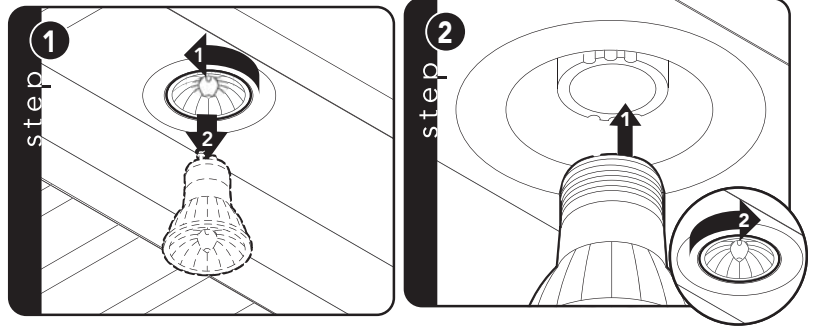

Service Information

If service is required, call your authorized service agency.

Have the following information readily available.

- Model number
- Serial number
- Date purchased
- Name of dealer from whom purchased

Clearly describe the problem that you are having. If you are unable to obtain the name of an authorized service agency, or if you continue to have service problems, contact Viking Range, LLC at 1-888-845-4641, or write to:

**VIKING RANGE, LLC
PREFERRED SERVICE
111 Front Street
Greenwood, Mississippi 38930 USA**

Record the information indicated below. You will need it if service is ever required. The model and serial number for your hood is located behind the baffle filter on the left side panel in the lower right corner.

Model no. _____ Serial no. _____

Date of purchase _____ Date installed _____

Dealer's name _____

Address _____

If service requires installation of parts, use only authorized parts to ensure protection under the warranty.

THIS MANUAL SHOULD REMAIN WITH THE HOOD FOR FUTURE REFERENCE.

Warranty

HOODS WARRANTY TWO YEAR FULL WARRANTY

Hoods and all of their component parts, except as detailed below*†, are warranted to be free from defective materials or workmanship in normal residential use for a period of two (2) years from the date of original retail purchase or closing date for new construction, whichever period is longer. Viking Range, LLC, warrantor, agrees to repair or replace, at its option, any part which fails or is found to be defective during the warranty period.

***FULL NINETY (90) DAY COSMETIC WARRANTY:** Product is warranted to be free from cosmetic defects in materials or workmanship (such as scratches on stainless steel, paint/porcelain blemishes, etc.) for a period of ninety (90) days from the date of original retail purchase or closing date for new construction, whichever period is longer. Any defects must be reported to the selling dealer within ninety (90) days from date of original retail purchase. Viking Range, LLC uses high quality processes and materials available to produce all color finishes. However, slight color variation may be noticed because of the inherent differences in painted parts and porcelain parts as well as differences in kitchen lighting, product locations, and other factors. Therefore, this warranty does not apply to color variation attributable to such factors.

†FULL NINETY (90) DAY WARRANTY IN "RESIDENTIAL PLUS" APPLICATIONS: This full warranty applies to applications where use of the product extends beyond normal residential use, but the warranty period for products used in such applications is ninety (90) days. Examples of applications covered by this warranty are bed and breakfasts, fire stations, private clubs, churches, yachts, etc. Under this "Residential Plus" warranty, the product, its components and accessories are warranted to be free from defective material or workmanship for a period of ninety (90) days from the date of original retail purchase. This warranty excludes use of the product in all commercial locations such as restaurants, food service locations and institutional food service locations.

FIVE YEAR LIMITED WARRANTY ON VENTILATION MOTORS

Any ventilator motor which fails due to defective materials or workmanship in normal household use during the third year through the fifth year from the date of original retail purchase will be repaired or replaced, free of charge for the part itself, with the owner paying all other costs, including labor.

TERMS AND CONDITIONS

This warranty extends to the original purchaser of the product warranted hereunder and to each transferee owner of the product during the term of the warranty and applies to products purchased and located in the United States, Canada, Mexico, and the Caribbean (excluding Cuba, Haiti, and Dominican Republic). Products must be purchased in the country where service is requested. If the product or one of its component parts contains a defect or malfunction during the full warranty period after a reasonable number of attempts by the warrantor to remedy the defect or malfunction, the owner is entitled to either a refund or replacement of the product or its component part or parts. Replacement of a component part includes its free installation, except as specified under the limited warranty. Under the terms of this warranty, service must be performed by a factory authorized Viking Range, LLC service agent or representative. Service will be provided during normal business hours, and labor performed at overtime or premium rates shall not be covered by this warranty.

Owner shall be responsible for proper installation, providing reasonable and necessary maintenance, providing proof of purchase upon request, and making the appliance reasonably accessible for service. The return of the Owner Registration Card is not a condition of warranty coverage. You should, however, return the Owner Registration Card so that Viking Range, LLC can contact you should any question of safety arise which could affect you.

This warranty gives you specific legal rights, and you may also have other rights which may vary from jurisdiction to jurisdiction.

WHAT IS NOT COVERED BY THIS WARRANTY: This warranty shall not apply to -consumable items such as filters and bulbs, damage resulting from abuse, failure to provide reasonable and necessary maintenance, accident, delivery, negligence, natural disaster, loss of electrical power to the product for any reason, alteration, outdoor use, improper installation, improper operation, or repair or service of the product by anyone other than an authorized Viking Range, LLC service agency or representative. This warranty does not apply to commercial usage.

LIMITATION OF REMEDIES AND DURATION OF IMPLIED WARRANTY

OWNER'S SOLE AND EXCLUSIVE REMEDY FOR A CLAIM OF ANY KIND WITH RESPECT TO THIS PRODUCT SHALL BE THE REMEDIES SET FORTH ABOVE. VIKING RANGE IS NOT RESPONSIBLE FOR CONSEQUENTIAL OR INCIDENTAL DAMAGE, INCLUDING BUT NOT LIMITED TO FOOD OR MEDICINE LOSS, DUE TO PRODUCT FAILURE, WHETHER ARISING OUT OF BREACH OF WARRANTY, BREACH OF CONTRACT OR OTHERWISE. Some jurisdictions do not allow the exclusion or limitation of incidental or consequential damages, so the above limitation or exclusions may not apply to you. Any implied warranties of merchantability or fitness for a particular purpose applicable to this product are limited in duration to the period of coverage of the applicable express written limited warranties set forth above. Some states do not allow limitations on how long an implied warranty lasts, so the above limitation may not apply to you.

WARRANTY SERVICE

To obtain warranty service, contact an authorized Viking Range, LLC service agent, or Viking Range, LLC, 111 Front Street, Greenwood, Mississippi 38930, (888) 845-4641. Provide model and serial number and date of original purchase or closing date for a new construction. For the name of your nearest authorized Viking Range, LLC service agency, call Viking Range, LLC. IMPORTANT: Retain proof of original purchase to establish warranty period.

Specifications subject to change without notice.

Viking Range, LLC
111 Front Street
Greenwood, Mississippi 38930 USA
(662) 455-1200

For product information call 1-888-845-4641, or visit the Viking Web site at vikingrange.com in the US or brigade.ca in Canada