

USE AND CARE MANUAL

DISCOVERY™ RANGE

Models ER36D, ER36D-C, ER48D, ER48D-C



Optional black knobs shown

Table of Contents

Important Safety Instructions	1
Getting to Know Your Range	4
Setting Up Your Range	8
Operating the Cooktop	11
Operating the Oven	13
Cooking Tips	23
Care and Cleaning	24
Before You Call for Service.....	30
Replacement Parts and Accessories	32
Warranty and Service	32
Warranty Card	Back Cover





To Our Valued Customer:

Congratulations on your purchase of the very latest in Dacor® products! Our unique combination of features, style and performance make us The Life of the Kitchen™, and a great addition to your home.

In order to familiarize yourself with the controls, functions and full potential of your new Distinctive Appliance, read this use and care manual thoroughly, beginning with the **Important Safety Instructions** section.

All Dacor appliances are designed and manufactured with quality and pride, while working within the framework of our company value. Should you ever experience a problem with your product, please first check the **Before You Call for Service** section of this manual for guidance. It provides useful suggestions and remedies prior to calling for service.

Valuable customer input helps us to continuously improve our products and services, so please feel free to contact our Customer Service Team for assistance with any of your product support needs.

Dacor Customer Service Team
14425 Clark Avenue
City of Industry, CA 91745

Telephone: (800) 793-0093
Fax: (626) 403-3130
Hours of Operation: Monday through Friday
6:00 A.M. to 5:00 P.M. Pacific Time
Web Site: www.dacor.com

Thank you for choosing Dacor for your home. We are a company built by families for families and we are dedicated to serving yours. We are confident that your new Dacor product will deliver a high level of performance and enjoyment for many years to come.

Sincerely,

The Dacor Customer Service Team

Important Safety Instructions

Installer: Leave these instructions with the appliance.

Consumer: Read this use and care manual completely before using this appliance. Save it for future reference.

For service and warranty information, see page 32.

If you have any questions, call:

Dacor Customer Service

(800) 793-0093 (U.S.A. and Canada)

Monday — Friday 6:00 A.M. to 5:00 P.M. Pacific Time

Web site: www.dacor.com

Have the complete model and serial number identification of your range ready. Record these numbers below for easy access. The numbers are found on a label inside the grill, inside the door. See the diagram below.

Model number _____

Serial number _____

Date of purchase _____

Serial number labels is located inside the grate

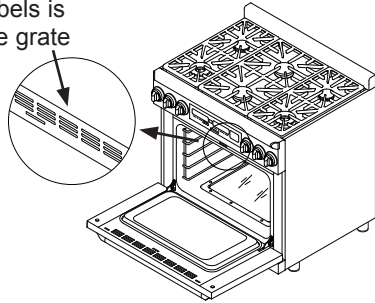

Model and Serial Number Location

Important Information About Safety Instructions

The **Important Safety Instructions** and warnings in this manual are not meant to cover all possible problems and situations that can occur. Use common sense and caution when installing, maintaining or operating this or any other appliance.

Always contact the Dacor Customer Service Team about problems or situations that you do not understand.

Safety Symbols and Labels

DANGER

Immediate hazards which **WILL** result in severe personal injury or death.

WARNING

Hazards or unsafe practices which **COULD** result in severe personal injury or death.

CAUTION

Hazards or unsafe practices which **COULD** result in minor personal injury or property damage.

WARNING

WARNING - NEVER use this appliance as a space heater to heat or warm the room. Doing so may result in carbon monoxide poisoning and overheating of the appliance.

WARNING

Tip-over hazard:

- A child or adult can tip the range and be killed.
- Verify that the anti-tip bracket has been properly attached to the floor or wall as directed in the installation instructions. Using a flashlight, verify that the range's anti-tip foot is engaged with the anti-tip bracket as shown below.
- After moving the range, be sure to re-engage the rear leg with the floor or wall mounted anti-tip bracket as shown below.
- Do not operate the range without the anti-tip foot engaged with the anti-tip bracket.
- Failure to follow these instructions can result in death or serious burns to children and adults.

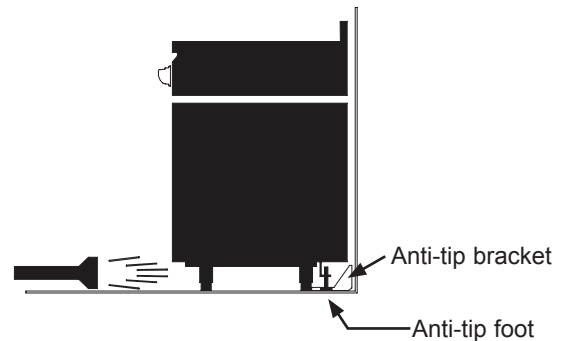

At Dacor, we continuously improve the quality and performance of all our products. We may need to make changes to this appliance without updating these instructions. Visit www.dacor.com to download the latest version of this manual.

CALIFORNIA PROPOSITION 65 WARNING

The burning of gas cooking fuel generates some by-products that are on the list of substances which are known by the State of California to cause cancer or reproductive harm. California law requires businesses to warn customers of potential exposure to such substances. To minimize exposure to these substances, always operate this unit according to the use and care manual, ensuring you provide good ventilation when cooking with gas.

READ AND SAVE THESE INSTRUCTIONS

Important Safety Instructions

General Safety Precautions

To reduce the risk of fire, electric shock, serious injury or death when using your range, follow basic safety precautions, including the following:

DANGER

IMPORTANT: If you smell gas:

- Do not use or light any appliance.
- Do not touch any electrical switch or use any electrical devices including the telephone in your building.
- From a neighbors phone, immediately call the gas supplier. Follow the gas supplier's instructions.
- If you cannot contact the gas supplier, call the fire department.

IMPORTANT: To avoid the possibility of explosion or fire, do not store or use combustible, flammable or explosive vapors and liquids (such as gasoline) inside or in the vicinity of this or any other appliance. Also keep items that could explode, such as aerosol cans away from the burners and the oven. Do not store flammable or explosive materials in adjacent cabinets or areas.

IMPORTANT: Child entrapment and suffocation are not problems of the past. Junked or abandoned appliances are still dangerous, even if they sit out for "just a few days." If you are getting rid of your old range, please follow the instructions below to help prevent accidents. Before you throw away your old range:

- Take off the oven door(s).
- Leave the racks in place so that children cannot easily climb inside.
- Cut the prongs off of the power plug.
- Cut off the power cable and discard it separately from the appliance.

WARNING

- If you receive a damaged product, immediately contact your dealer or builder. Do not install or use a damaged appliance.
- Make sure that the range has been properly installed and grounded by a qualified installer according to the accompanying installation instructions. Have the installer show you the location of the gas shut off valve and the fuse or junction box so that you know where and how to turn off the gas supply and power to the range.
- If the wall behind the cooktop is constructed of combustible material, the installer must attach the optional 3", 9", or 24" backguard to the back of the range instead of the island trim. Do not operate the range without the backguard in place if the back wall is made of combustible materials. A fire may result.
- Do not install, repair, or replace any part of the range unless specifically recommended in the literature accompanying it. A qualified service technician should perform all other service.
- Before performing any type of service, make sure that the gas supply and electrical power to the range is turned off.
- NEVER block or cover any slots, holes or passages anywhere inside the oven or on the outside of the range. Doing so blocks airflow through the oven and cooktop and may cause carbon monoxide poisoning or fire. See the **Getting to Know Your Range** section for the location of the various air holes (slots).
- Only use the range for cooking tasks expected of a home appliance as outlined in this manual. This range is not intended for commercial use.
- DO NOT TOUCH THE SURFACES OF THE OVEN OR COOKTOP DURING OR IMMEDIATELY AFTER USE.
- Make sure individuals who use the range are able to operate it properly.
- Never allow anyone, including children to sit, stand or climb on any part of the range, including the door(s). Doing so may cause tipping, damage, serious injury or death.
- Do not leave children alone or unattended in the area around the range. Do not allow children to play with the controls, pull on the handle(s) or touch other parts of the range.
- Do not store items of interest to children on top of or above the range. Children could be burned or injured while climbing on the appliance.
- Do not attempt to use this appliance in the event of a power failure.
- Do not tamper with the controls.
- Do not cover the burners and grates with anything except properly selected utensils. Decorative covers may cause a fire hazard or damage to the range if a burner is accidentally turned on with the cover in place.
- Do not heat unopened food containers such as baby food jars and cans. Pressure build up may cause the container to burst and cause injury.
- Clean the cooktop thoroughly before operating it for the first time.

Important Safety Instructions

WARNING

- NEVER cover any slots, holes or passages in the oven bottom or cover an entire rack with materials such as aluminum foil. Doing so blocks air flow through the oven and may cause carbon monoxide poisoning. Aluminum foil linings may also trap heat, causing a fire hazard.
- Do not use water on grease fires. A violent steam explosion may result. Smother any flames with a lid, cookie sheet or flat tray. Use baking soda or a foam extinguisher to extinguish flaming grease. Be careful to avoid getting burned.
- Keep flammable items, such as paper, cardboard, plastic and cloth away from the burners and other hot surfaces. Do not place such items in the oven. Do not allow pot holders to touch hot surfaces or gas burners.
- Do not wear loose or hanging apparel while using the range. Do not allow clothing to come into contact with the interior of the oven or the cooktop and surrounding areas during and immediately after use.
- Do not use towels or bulky cloth as pot holders.
- Do not hang flammable or heat sensitive objects over the range.
- If the range is near a window, do not use long curtains as window treatment. The curtains could blow over the cooktop and create a fire hazard.
- To avoid the possibility of fire, do not leave the range unattended when using the cooktop.
- When deep fat frying:
 - Be certain that the pan is large enough to contain the desired volume of food without overflow caused by the bubbling of the fat. Never leave a deep fat fryer unattended.
 - Avoid frying moist or frost-covered foods. Foods with high water content may cause spattering or spilling of the hot fat.
 - Heat fat slowly, and stir together any combination of oils and fats prior to applying heat. Utilize a deep fat frying thermometer to avoid heating the fat to temperatures above the flash point.
- Do not use the oven for storage.
- Clean and maintain the range regularly as instructed in this manual. Keep the entire range, ventilation filters and range hoods free of grease that could catch fire.
- Do not touch the burner assembly, grates and surrounding surfaces (including the backguard) or the interior surfaces of the oven(s) during use. After use, make sure these surfaces have had sufficient time to cool before touching them.
- Do not touch the outside surfaces of the range during the self clean cycle. They will be hot. Venting from the oven may cause the cooktop and backguard to become hot.
- Before using glazed cookware, such as glass, ceramic, or earthenware, check the manufacturer's temperature and usage recommendations. Glazed cookware that is not designed for high heat use may crack or break, causing a spill or burn hazard.
- Exercise caution when opening the oven door(s). Let hot air or steam escape before looking or reaching into the oven(s).
- Use extreme caution if adding water to food on a hot cooktop or in the oven. The steam can cause serious burns or scalds.
- Use only dry pot holders when removing food and cookware from the cooktop or oven. Wet pot holders can cause steam burns.
- Make sure that all the cooktop parts are dry before lighting a burner.
- Use cookware only for its intended purpose. Check the manufacturer's recommendations before use to determine if a utensil is suitable for use on a cooktop or in an oven. Certain types of glass, ceramic, and earthenware are not suitable for use on a cooktop. Personal injury or damage may result from the improper use of cookware.
- Select cookware carefully. Use utensils of the proper size, material and construction for the particular type of cooking being done. Utensils need to be large enough to contain the desired quantity of food without boil-overs or spill-overs. Choose pans with easy to hold handles that will stay cool while cooking. Do not use utensils with loose handles. Avoid using pans that are too heavy to lift safely.
- Turn the knobs to the **OFF** position prior to removing them from the valve stems.
- The cooktop should never be operated without the knobs and trim rings in place.
- For your safety, do not use the oven to cook without the convection filter(s) installed. When the filter is not installed, the spinning fan blades at the back of the oven are exposed.
- Do not allow food to sit in the oven for more than one hour before or after cooking. Eating spoiled food can result in food poisoning.
- Non-stick coatings, when heated, can be harmful to birds. Remove birds to a separate, well-ventilated room during cooking.

Important Safety Instructions

CAUTION

- Do not allow acids (citrus juices, tomato sauces, etc.) to remain on the range's surfaces. The porcelain finish may stain.
- Never use the cooktop surface as a cutting board.
- Do not try to remove heavy spills with a sharp object such as a knife or metal spatula. Sharp objects may scratch the range's surfaces.
- To prevent damage, remove the meat probe from the oven when it is not being used.
- Do not line the oven with aluminum foil or other materials. These items can melt or burn up during self cleaning and cause permanent damage to the oven(s).
- Do not leave metal objects, such as aluminum foil, the meat probe, cookie sheets, etc. on the bottom of the oven(s). Objects left on the bottom of the oven could damage the bake element. In addition, the objects themselves may be damaged.
- On some ovens, the bake and broil elements are behind glass panels on the floor and ceiling of the oven chamber. Do not allow these glass panels to become covered up by cookie sheets, aluminum foil, pots, pans, etc. Covering them could cause the heating elements to over-heat, damaging the oven.
- Do not expose the knobs or trim rings to direct flame, hot utensils, or other sources of heat.
- Always ensure that the light fixture lens covers are in place when using the oven(s). The lens covers protect the light bulbs from breakage caused by high oven temperatures or mechanical shock.

Getting to Know Your Range

Model Identification

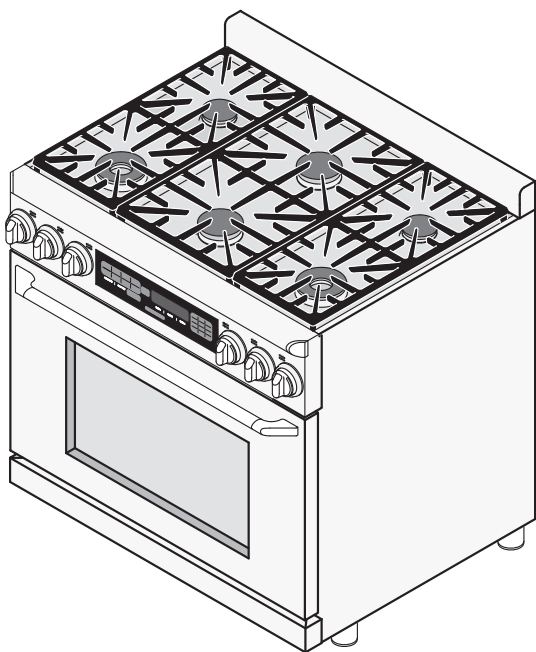

36-Inch (ER36D): 6 Burners - 1 Oven

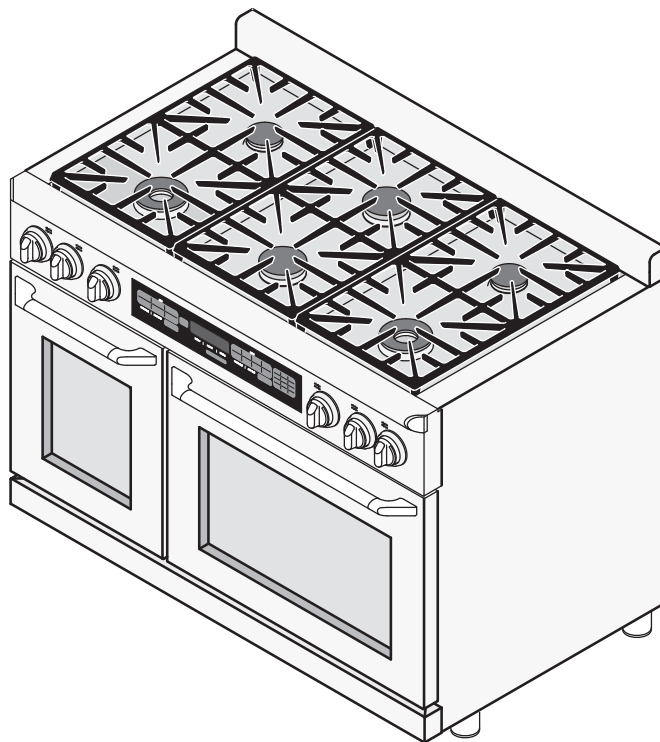

48-Inch (ER48D): 6 Burners - 2 Ovens

Getting to Know Your Range

About the Cooktop

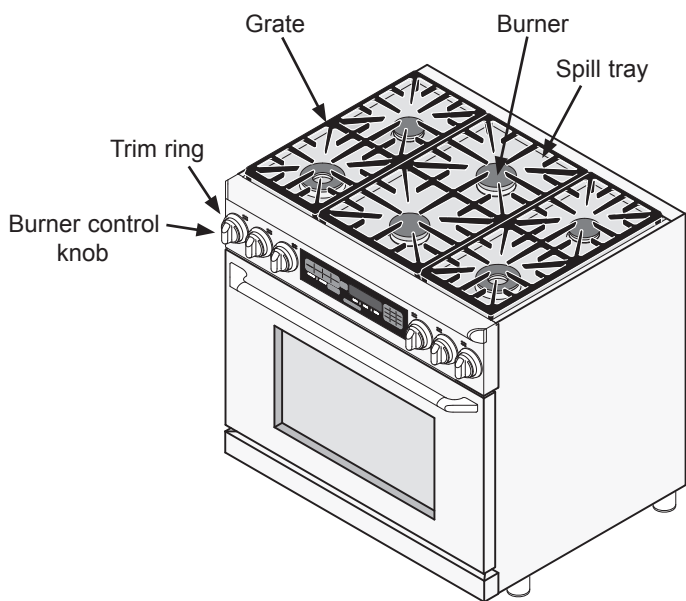

Model ER36D with Island Trim

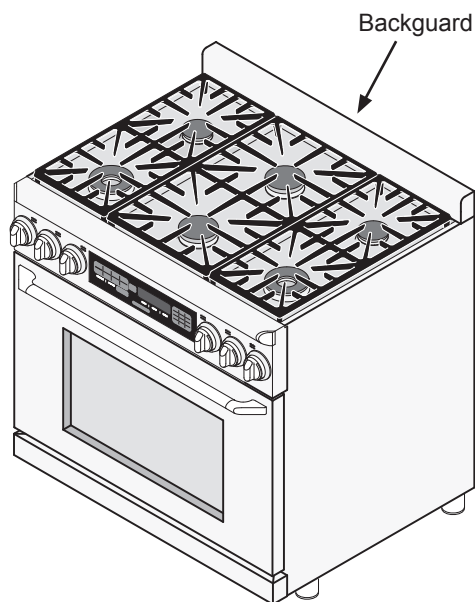

Model ER36D with Backguard

BACKGUARD: The range comes with the standard island trim package. The optional backguard comes in three sizes, 3", 9" or 24". It is attached by the installer if the wall behind your range is combustible. It protects the wall from the effects of heat and splattering grease. See the installation instructions.

SPILL TRAY: The spill tray catches any food that falls through the cooktop grates.

GRATES: The porcelain coated cast iron grates support the cooking utensils during cooking. They are removable to allow the area below and around the burners to be cleaned easily. The size and location of the grates depends on the model of the range.

BURNERS: The size and location of each burner depends on the range model. The range generates a spark to light the burner when you turn the knob to **ON**. Gaskets around the underside of the burner bases prevent spilled liquids from leaking into the range's internal parts.

BURNER CONTROL KNOBS: Use the knobs to turn on the burners and adjust the flame size. The corresponding knob illuminates when a burner is on.

TRIM RINGS: Located behind each knob. They prevent liquids from getting into the range's internal parts.

Burner Locations

- A. 2000 to 8500 BTU stack burner
- B. 2200 to 16000 BTU stack burner
- C. 1000 to 18000 BTU crown burner

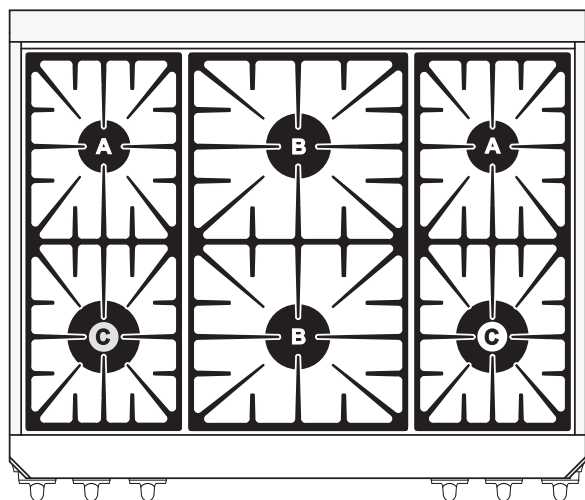

Special Cooktop Features

Perma-Flame™: The Perma-Flame instant re-ignition feature automatically re-lights a burner quickly if it goes out. With Perma-Flame, your cooking experience is uninterrupted because the flame is re-ignited at the same level as when it went out.

Smart Flame™: Smart Flame technology reduces the temperature under the fingers of the porcelain-coated cast iron grates. Smart-Flame extends grate life and protects the finish.

SimmerSear™: Dacor's exclusive precision burner control system. It allows you to cook with a wide range of heat settings, from simmer to sear.

Getting to Know Your Range

Parts of the Oven

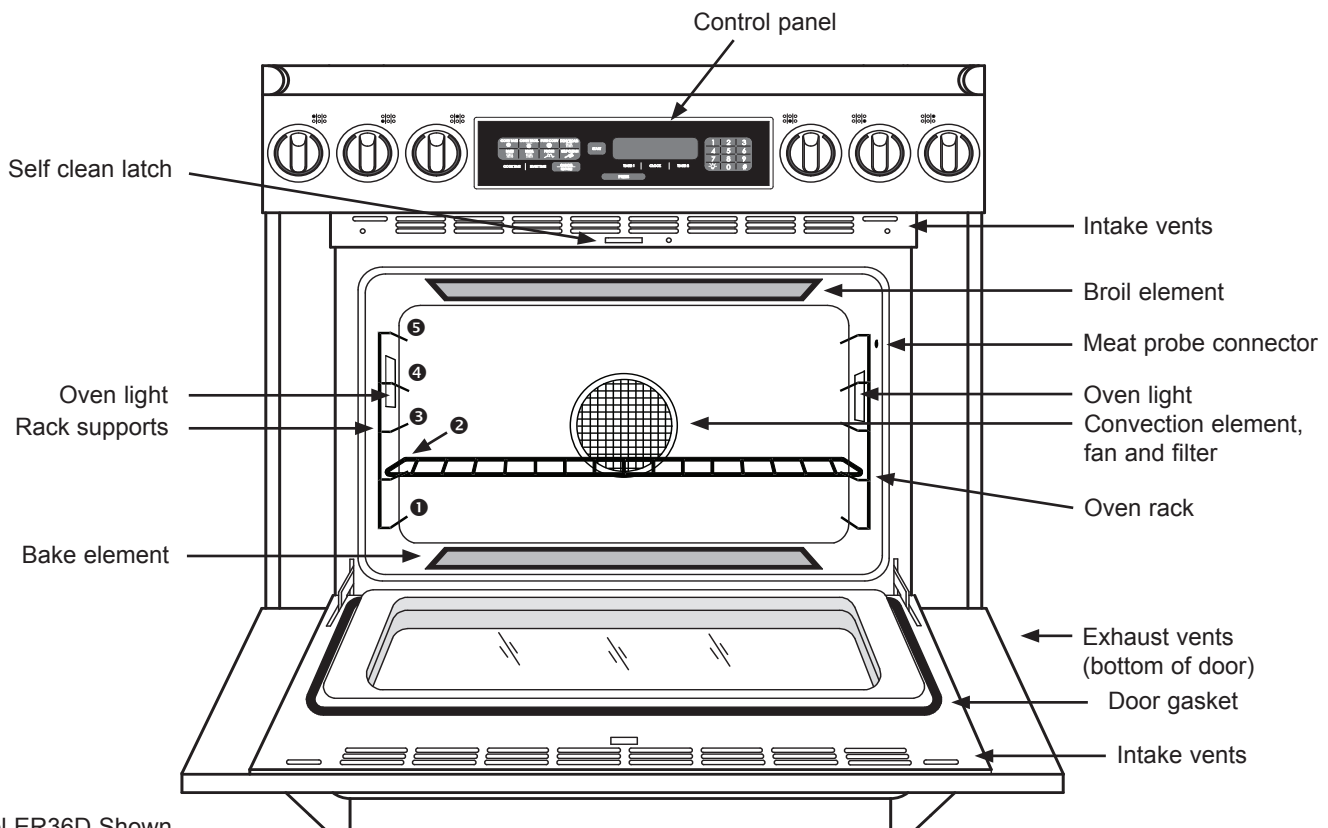

Model ER36D Shown

CONTROL PANEL: Your oven's control panel consists of a touch pad and a display. Use the control panel to operate all the oven's features (sometimes called modes).

OVEN RACKS: Each oven comes with chrome-plated adjustable oven racks. See the table below for the number and type provided with your model. Page 13 describes the difference between rack types.

Rack Type	ER36D	ER48D
Standard	1	1 - 26", 3 - 18"
GlideRack™	2	2 - 26"

RACK SUPPORTS: There are five rack positions inside each oven chamber. The rack positions are numbered from the bottom counting up.

MEAT PROBE CONNECTOR: When you use the meat probe, insert the skewer into the meat and plug the other end into the connector. The left oven on model ER48D does not have the meat probe feature. See the **Meat Probe** section on page 20 for proper operation.

BAKE ELEMENT: The source of bottom heat, attached to the floor of the oven. The bake element for the model ER36D oven and the large oven on model ER48D are hidden below the glass panel on the floor of the oven chamber.

BROIL ELEMENT: The source of top heat, attached to the oven's ceiling. The broil element for the model ER36D oven and the large oven for model ER48D are hidden above the glass panel on the ceiling of the oven chamber.

CONVECTION FAN: The convection fan blows heated air into the oven chamber during the convection cooking process. The convection filter covers it.

CONVECTION ELEMENT: The convection element heats the air that is blown into the oven chamber by the convection fan during the convection cooking process. The convection filter covers it.

CONVECTION FILTER: The convection filter covers the convection fan. It helps prevent the transfer of taste from one food to another when you are cooking a whole meal. It also keeps the oven cleaner, especially when convection roasting or convection broiling. In addition, it covers the moving convection fan blades for safety purposes.

OVEN LIGHTS: There are two oven lights inside the oven chamber so that you can easily see inside (the left oven on model ER48D has only one). You can use the lights when the door is open or to see inside through the window when the door is closed. The lights turn on or off only when you press the light key on the control panel. The bulbs are 12 Vac, 20 Watt, halogen.

DOOR GASKET: The door gasket prevents heat from escaping when the door is closed.

Self clean LATCH: The self clean latch automatically locks the oven door during the self clean cycle. The door latches for your safety. There are very high temperatures inside the oven during the self clean cycle.

Getting to Know Your Range

Control Panel Layout

DISPLAY: The control panel display provides various types of information about the oven, including the current time (once the clock is set), the current cook settings and the cooking temperature. The control panel can pivot up for easier access.

NUMBER KEYPAD: When you want to set the temperature, cook time or the time, use the number keypad.

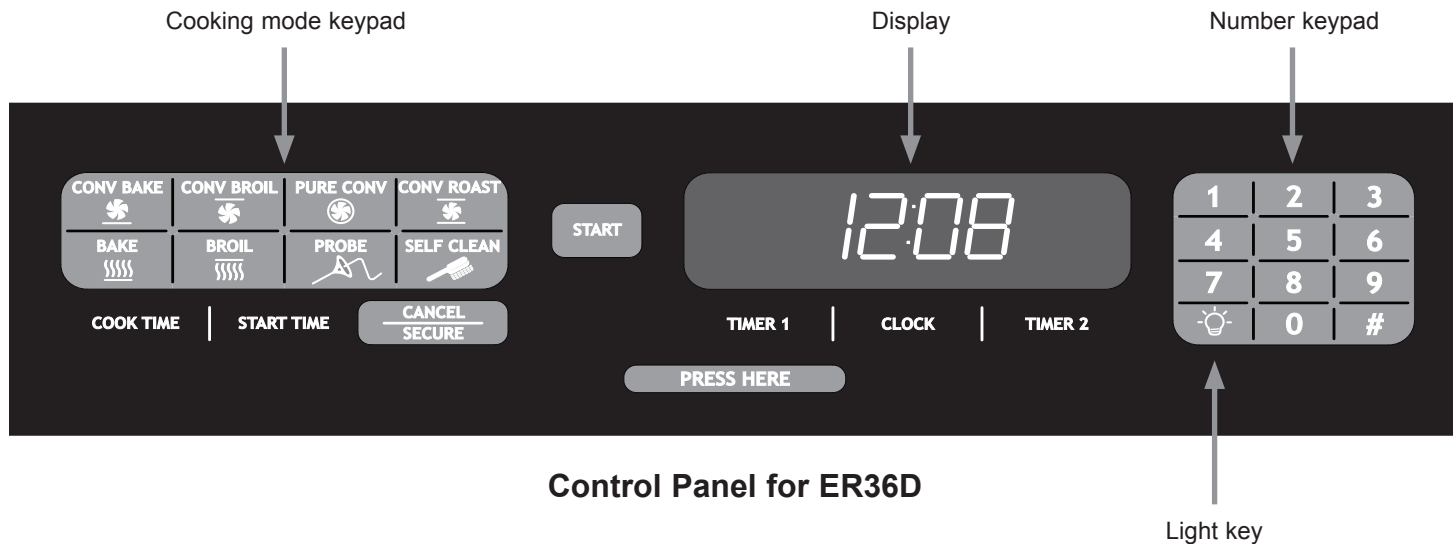

Control Panel for ER36D

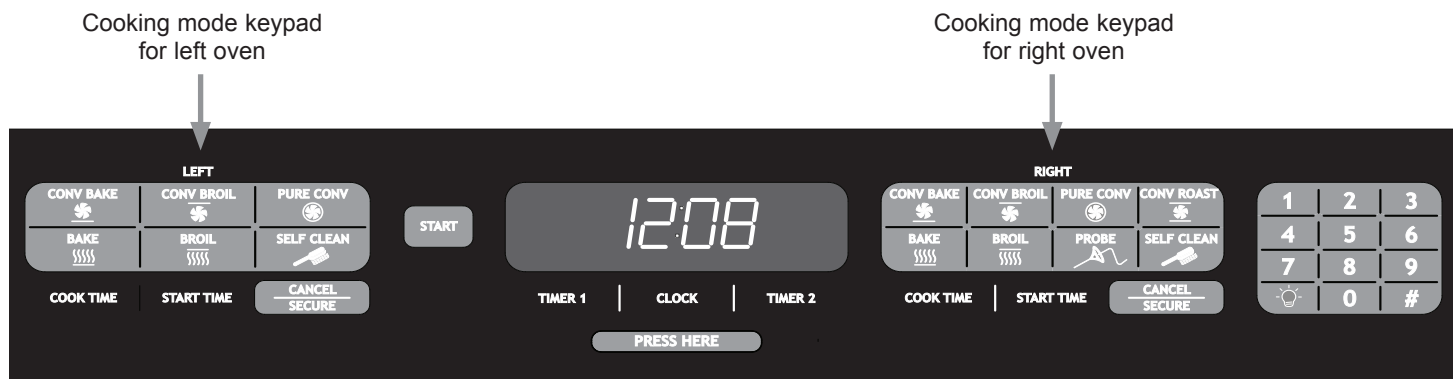

Control Panel for ER48D

Control Panel Keys

CLOCK: Use this key to set the clock.

TIMER: Use the **TIMER 1** and **TIMER 2** keys to time an event. The two timers operate separately from each other. You can use them even if the oven is not in use. They do not turn the oven on or off. See page 18 for instructions.

START: When you use the various features (or modes) on your oven, select the cooking mode first, then press the **START** key. Also use the **START** key to start the timers.

CANCEL-SECURE: Use this key to turn off your oven. This key sets all temperature settings back to zero and turns off any features (except the timer) that are currently in use. It also activates the lock-out feature.

LIGHT: Located on the number keypad. If you need to turn the oven lights on or off, press the light key.

COOKING MODES: Select the type of cooking you want to perform by pressing one of the cooking mode keys. Also includes the **Self clean** and **PROBE** keys.



Selects the oven's self clean feature.



Press this key if you want to use the meat probe to monitor the internal cooking temperature of meat when roasting. There is no meat probe for the left oven on model ER48D.

Setting Up Your Range

Cooktop Assembly

WARNING

To avoid the chance of fire, explosion or carbon monoxide poisoning, do not attempt to use your range without the burners completely and properly assembled. The burner rings spread the flame evenly around the burner cap. The burner rings must be properly seated for proper burner lighting and operation.

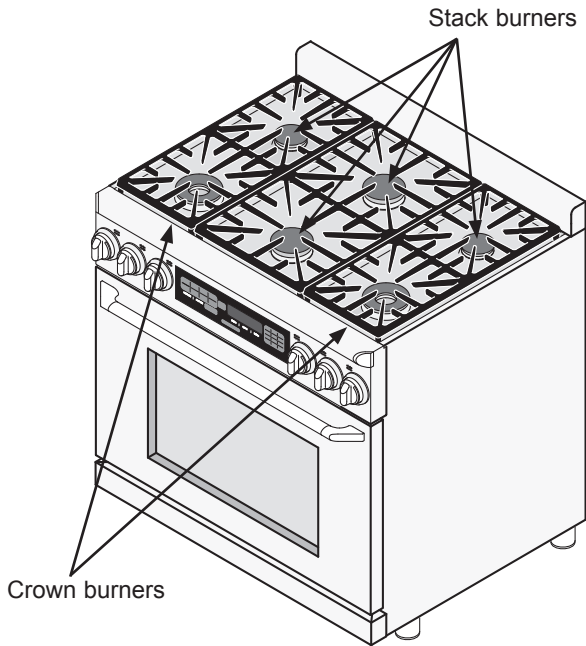

Burner Locations

Stack Burner Assembly

1. Put the burner rings on the burner bases as shown below. Match the correct sizes. The bottom of the correct size burner ring fits inside the top of the matching burner base.
2. Turn the ring until it drops into place. Twist each ring back and forth slightly to make sure it is properly seated.
3. Put the burner caps on top of the burner rings. The ridge around the bottom edge of the cap goes around the top of the burner ring.

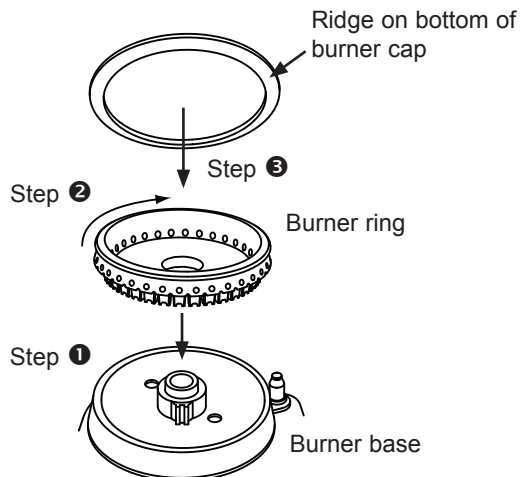

Crown Burner Assembly

1. Put the burner heads in place as shown below. The locating tab on the burner head goes in the keyed hole as shown.
2. Put the burner rings on the burner heads as shown below. Match the tabs on the bottom of the ring to the slots on the burner head. Twist each ring back and forth slightly to make sure it is properly seated.
3. Put the burner caps on top of the burner rings. The ridge around the bottom edge of the cap goes around the top of the burner ring.

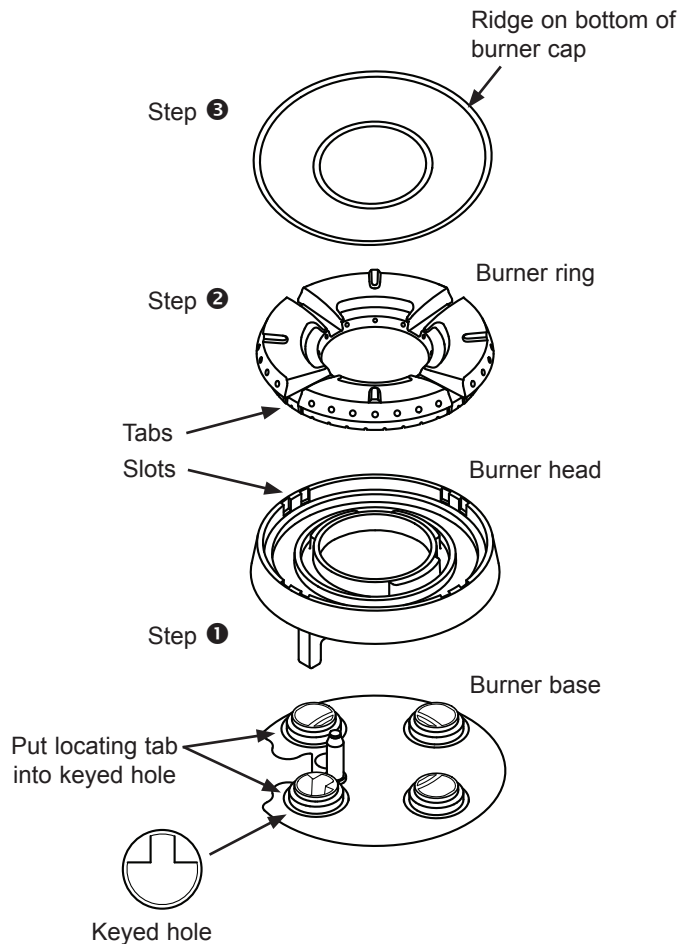

Setting Up Your Range

Grates

Gently set the grates on top of the spill tray. Put the legs of each grate into the corresponding dimples. On the model ER36D, the middle grate is larger than the other two.

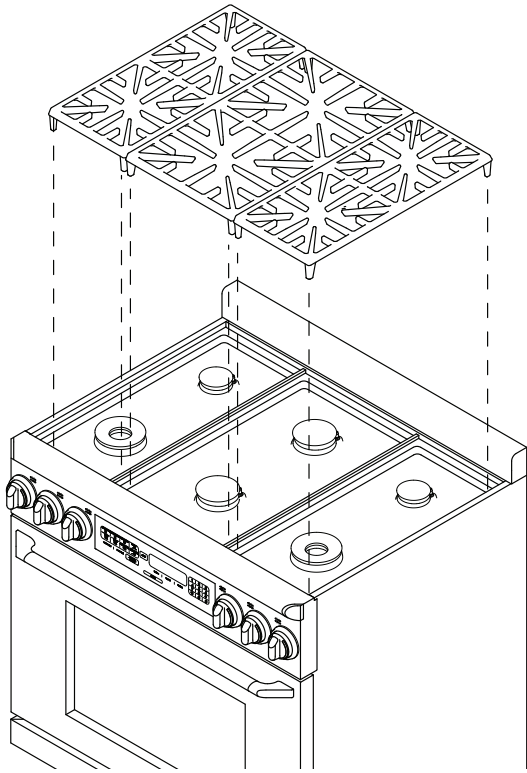

2. When installing the knobs, align the "D" shaped opening on the back of the knob with the end of the valve shaft. Carefully push the knob on until it stops.

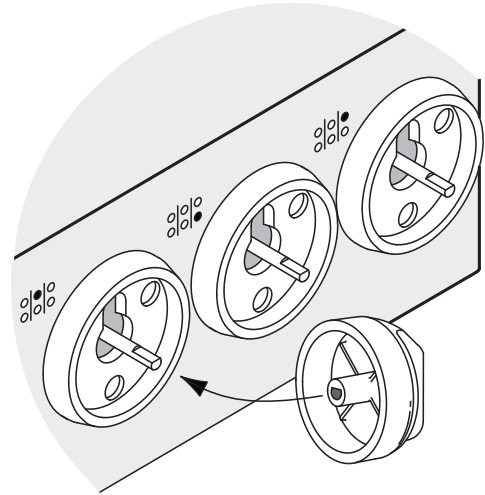

3. Put the remaining knobs on the outer valve shafts.

Installing the Burner Knobs

There are two different types of knobs for the range. The knobs for the center burners have the words "**MAX GRIDDLE**" on them.

1. Put the knobs with "**MAX GRIDDLE**" written on them onto the inner (center burner) valve shafts.

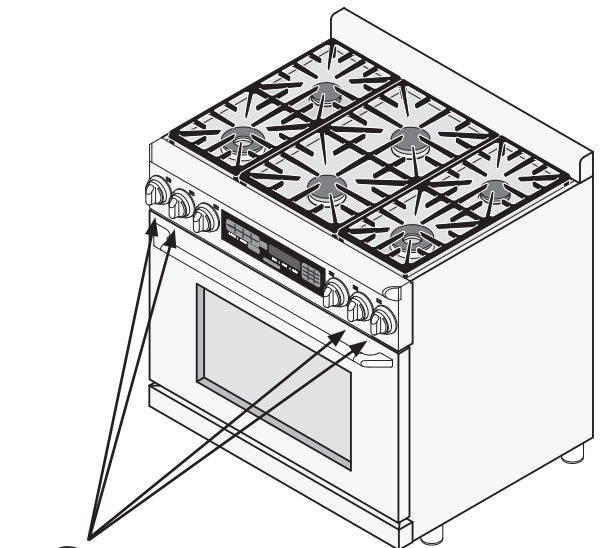
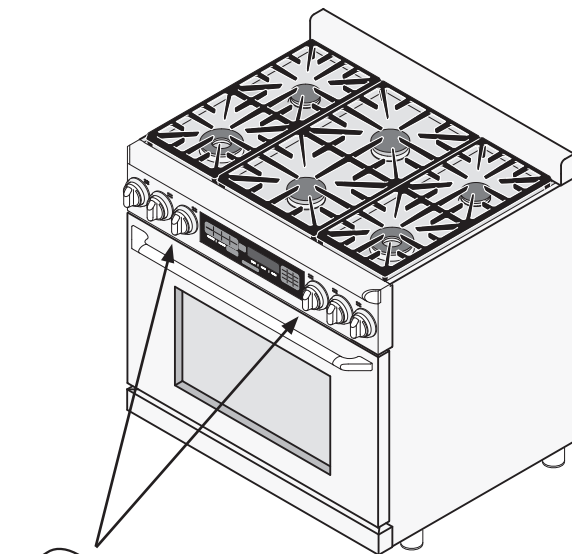

CAUTION

Installing the range knobs in the wrong position may result in damage to the griddle included with the range. The knobs for the center burners are marked with the maximum griddle settings.

Setting Up Your Range

Control Panel Settings

Setting the Time

IMPORTANT:

- The clock cannot be set during delay timed cooking or if one or both timers are in use.
- After a power failure, the time on the display may flash, indicating that the time may not be correct.

To set the time:

1. Press the **CLOCK** key. "TIME" will flash on the display.
2. Enter the current time and press **START**. For example: For 12:08 Press 1-2-0-8 on the keypad, then **START**.

IMPORTANT: After pressing the clock key, you must enter the time and press **START** soon afterward. If you wait longer than six seconds between pressing keys, the display will go back to the original setting.



↑
Clock key

24/12 Hour Clock (Military Time)

The range is set to 12-hour (non-military) time at the factory. 24-hour time is also known as military time. 1:36 PM = 13:36 military time.



If you want to switch the clock to 24 hour time or switch from military back to regular time:

1. Press and hold the clock key for six seconds. The display will indicate the mode the clock is currently set to, **12 HR** or **24 HR**.
2. Press the **SELF CLEAN** key within six seconds to change the clock mode. To leave the setting as is, do not touch any keys.
3. Wait six seconds. The control panel will go back to the regular clock display, set to the new time standard. If you have set the clock to 24 hour time, the keypad will allow you to enter military time when setting the clock.

Setting the Temperature Scale

The control panel allows you to select the temperature scale (Fahrenheit or Celsius) it uses to display the cooking temperature. The oven is preset at the factory to Fahrenheit.

To change the temperature scale:

1. Press and hold the **BROIL** key for six seconds.
2. The display will indicate the temperature scale the control panel is currently set to, "F" or "C".
3. Press the **SELF CLEAN** key within six seconds to change the temperature scale. To leave the setting as is, do not touch any keys.
4. Wait six seconds. The control panel will go back to the regular clock display, set to the new temperature scale.

Control Panel Position

The control panel can be swiveled to a 50° angle for easier viewing and use.

To pivot the control panel:

1. Push in on the bottom of the control panel where it says "PRESS HERE." The control panel will pivot up.
2. Pull up on the bottom of the control panel housing (under "PRESS HERE") until it locks in place.

To put the control panel back in the vertical position:

1. Pull up on the bottom of the control panel housing (under "PRESS HERE") to unlock it.
2. Push in where it says "PRESS HERE" until it locks into the vertical position.

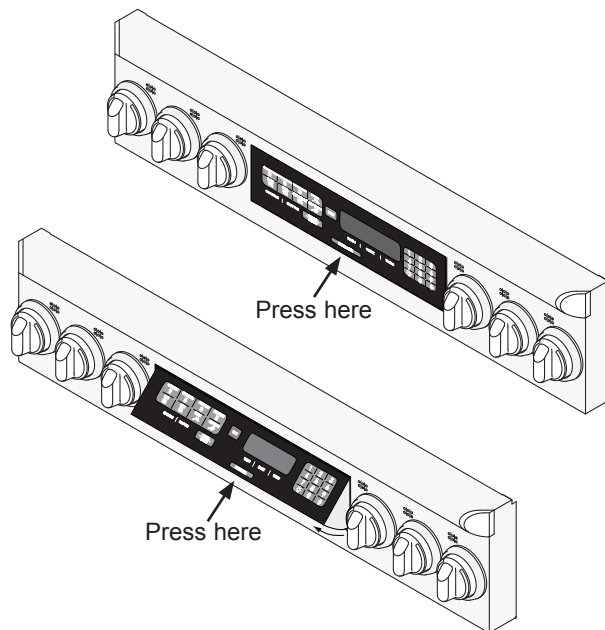

CAUTION

When changing the control panel position, push in only on the spot marked "PRESS HERE". If you push in on the right or left side you may damage the pivot mechanism.

Operating the Cooktop

WARNING

- Always check the position of the control knobs to make sure the cooktop is off when you are finished cooking.
- Do not operate the cooktop without all the burner components in place. If the burner ring and cap are not properly seated, the burner may not operate correctly. See page 8 for assembly instructions.
- Never light the burners with a match or other open flame.

IMPORTANT:

- Avoid spills as much as possible. The porcelain surfaces of the grates, spill trays, and burner caps are acid-resistant but not acid-proof. Some foods can cause permanent damage if allowed to remain on porcelain surfaces.
- To keep the burners operating properly, keep the burner igniters, burner rings and burner caps clean and dry. See page 26 for cleaning instructions.

CAUTION

Cookware with rough bottoms can cause permanent damage to the coated surfaces.

Selecting the Cookware

For overall safety and best performance, select the correct cooking utensil for the food being cooked. Improperly selected cooking utensils will not cook evenly or efficiently.

Use cookware that:

- Has flat, smooth bottoms
- Is well balanced
- Has tight fitting lids to keep heat, odors and steam in

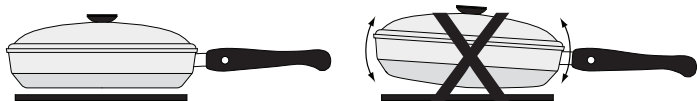

WARNING

- To avoid burns and scalding, always turn pan handles to a position where they cannot be easily hit. Also, handles should not extend over adjacent burners. Always set utensils gently onto the grates and center them so that they are well-balanced.
- Do not drag cookware across the grates. Sliding may damage the finish. Lift utensils to reposition them. Do not drop them on the grate.
- To avoid burns or fire hazard, reduce the flame level if it extends beyond the bottom of the utensil. A flame that extends up the sides of the utensil is potentially dangerous.

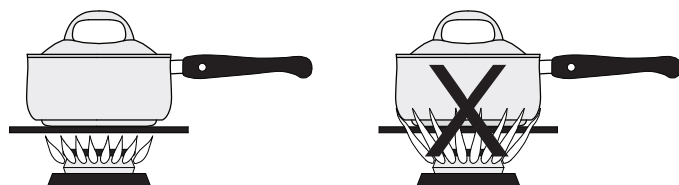

Lighting a Burner

WARNING

- In the interest of safety, always light the burner first before putting the cooking utensil on the grate. Turn the burner knob to the **OFF** position before removing the utensil.
- Do not turn the knob past the **HIGH** position until lit. Doing so may result in a burst of flame that could cause burns or damage to the surrounding area.
- Do not touch any burner cap, burner base or igniter while the igniter is sparking. An electrical shock could result.
- If the gas does not ignite after four seconds or if the flame goes out and gas escapes, turn the knob to the off position. Open a window and allow at least five minutes for the gas to dissipate. Repeat the lighting procedure.

Each burner control knob has a small diagram next to it to tell you which burner it operates.



To Light a Burner:

1. Push in on the knob and turn it counter-clockwise to the **HIGH** position. The igniter for the burner will spark repeatedly until it lights. The spark makes a "clicking" sound. The burner should light within four seconds.

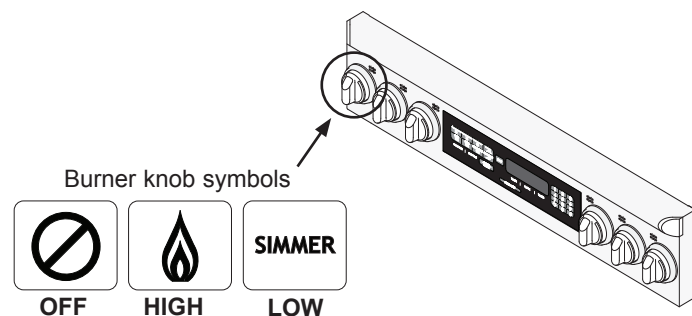

2. The flame should burn evenly around the perimeter of the burner, except underneath each grate support finger, where the flame height is reduced by Dacor's Smart Flame feature. A normal flame is steady and blue in color. Foreign material in the gas line, especially in new construction, may cause an orange flame during initial operation. This will disappear with further use. Small yellow tips on the ends of the flames are normal when using LP gas.
3. If a burner does not ignite, the igniter continues to spark or if the flame is not spread evenly around the burner cap, see the **Before You Call for Service** section on page 30.
4. Place the cooking utensil on the grate.
5. Adjust the flame to the level necessary to perform the desired cooking process.

IMPORTANT: When the cooktop is cool, the igniter may continue to spark if the control knob is set to the low position. The burner will stop sparking when warm. The tendency to spark when cold can be reduced by operating the burner at a higher flame setting for about 60 seconds. After 60 seconds, lower the flame to cook. The burner will also warm up faster if a utensil is placed on the grate. The igniter will also spark automatically if the flame is distorted by a draft or by the household ventilation system. Eliminate any drafts or reduce the ventilation blower speed to reduce this type of problem.

Operating the Cooktop

Cooktop Tips

- Dacor's SimmerSear feature allows you precision control of the flame. The larger the burner size, the wider the range of control. See page 5 for the heat ranges of the different burners.
- Food cooks just as quickly at a gentle boil as it does at a vigorous, rolling boil. Maintaining a higher boil than necessary wastes energy and cooks moisture, food flavor and nutrients out of the food.
- Use a low or medium flame when cooking with utensils that are poor conductors of heat, such as glass, ceramic or cast iron. Reduce the flame until it covers approximately 1/3 of the utensil diameter. Doing so will ensure even heating and reduce the likelihood of burning or scorching the food.

Using the Griddle

For best results, allow the griddle to preheat for about 10 minutes before you start to cook.

1. Before using the griddle for the first time, wash it in hot, soapy water. Rinse it and allow it to dry thoroughly.
2. With all of the burners off and the range cool to the touch, put the griddle over the top of the center grate on the range*. The grease trap goes toward the back of the range. Fit the tabs that stick out of the bottom of the feet into the inside corners of the grate. When it is correctly installed, the griddle will rest securely about 1/2" above the top surface of the grate. It may rock slightly, which is normal.
3. Turn the center front burner knob to the light (high) position. Once lit, turn the knob to the **MAX GRIDDLE** position, or lower if desired. **DO NOT** keep the burner knobs higher than the **MAX GRIDDLE** setting after they are lit!
4. Repeat step 3 for the center rear burner knob.

During cooking be careful with metal utensils on the surface because they can scratch the non-stick coating.

Clean the griddle after each use. See page 28 for instructions.

* The center grate has burners of the same size in the front and back for even heating.

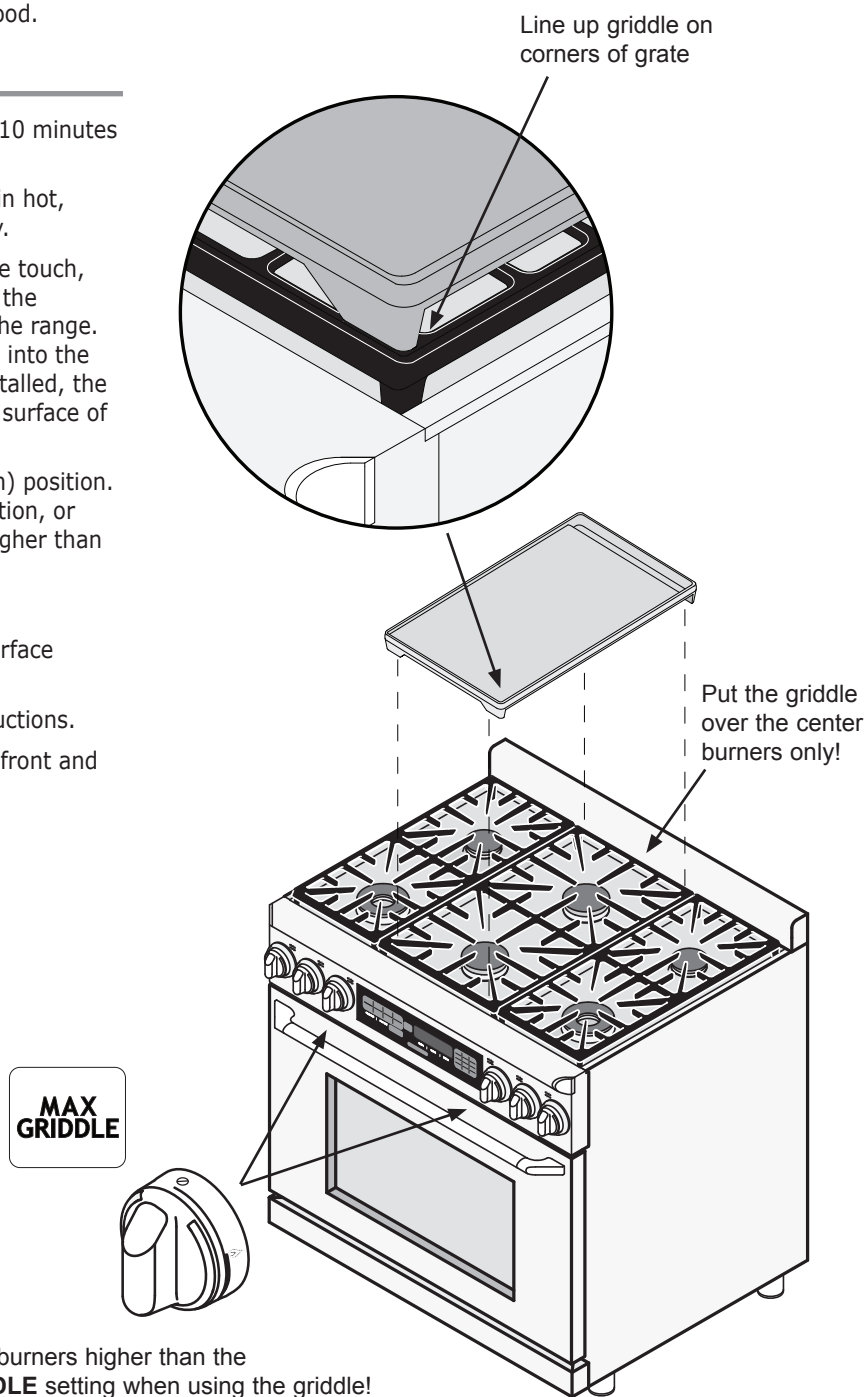

Operating the Oven

Before You Cook...

- When you use your oven to bake or roast, it preheats automatically. The preheat cycle rapidly brings the oven chamber up to the proper cooking temperature. It takes several minutes to preheat the oven. Preheat time depends on the temperature settings. The time may be longer depending on the type of electrical supply in your community. There is no preheat cycle for any of the broil modes.
- After you pull food out of the oven, it will continue to cook. This process is called "carry-over". The larger the portion of food, the longer it will cook. It is best to let the meat rest after it comes out of the oven for 10 to 15 minutes before carving. Doing so will allow the meat to retain its juices and make it easier to carve.
- Dacor recommends turning the oven on for one hour at 500°F to burn off any residual oils used during the manufacturing process. Any of these oils left on the inner parts can cause an undesirable smell the first few times the oven is used.

Oven Racks

You may use either rack type on any level.

WARNING

To reduce the chance of burns, position the oven racks when the oven is cool. If you must reposition a rack when the oven is hot, use potholders.

To Insert Standard Oven Racks:

1. Insert the end of the rack with the safety notches into the oven first.
2. Attach both sides of the rack to the rack supports in the oven as shown in the diagram below.
3. Begin to slide the rack in, and then, lift up so that the safety notches clear the ends of the rack supports.
4. Push the rack all the way in with both hands.

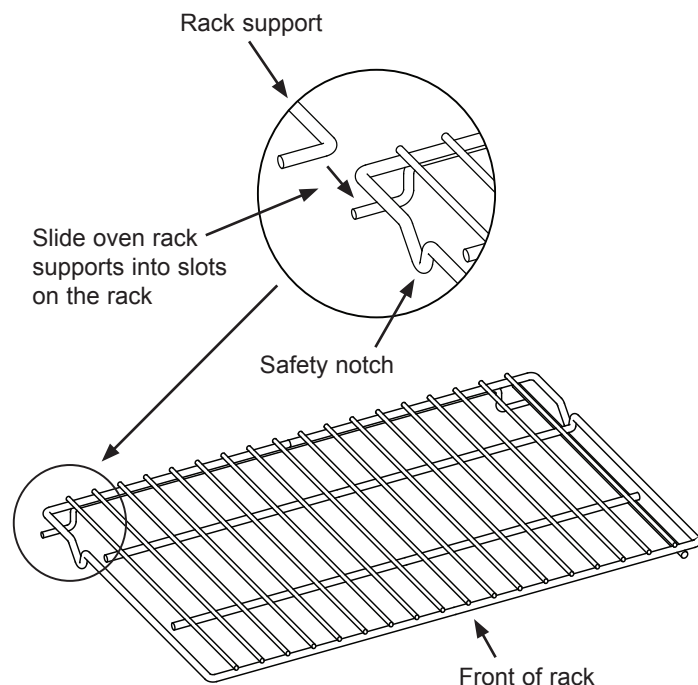

To Remove Standard Oven Racks:

- If you want to remove an oven rack, grasp it with both hands and pull gently straight out toward you until it stops.
- To remove the rack completely, lift the front of the rack up about six inches and continue to pull it out. Lifting the rack releases the safety notches. The safety notches reduce the chances of a rack coming out of the oven accidentally.

To Insert Your GlideRack Oven Racks:

Your oven comes with Dacor GlideRack oven racks. When you use them, you can effortlessly slide heavy pots, pans or other items out to check, stir or add ingredients quickly and safely.

1. Extend both rack guides completely as shown below.
2. Align both sets of safety clips (right and left) on the back of the rack guides with the oven rack supports as shown.
3. Insert the rack into the oven, sliding the rack supports between the rear safety clips as shown. As you slide the rack in, hold the front of the rack up slightly until the front safety clips just clear the front of the rack supports.
4. Lower the front of the rack so that the front of the rack support is between the front safety clip and the rack stop.
5. Grasp the rack in the center of the front and pull. The rack should come forward while the guides remain in place.

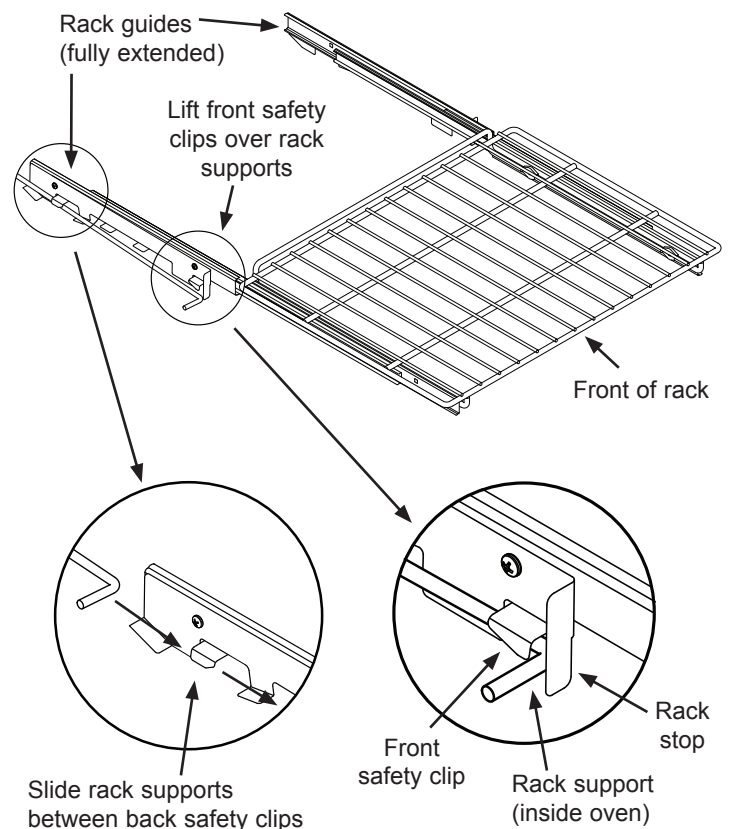

To Remove Your GlideRack Oven Racks:

- Grasp the rack with both hands and pull it gently straight out toward you until it stops.
- Lift up until the front safety clips just clear the front of the rack supports on the oven. Continue to pull out. Moving the end of the rack back and forth slightly, left to right, as you pull, will make it easier to remove.

Operating the Oven

Starting Your Oven

1. Adjust the racks to the appropriate level.
2. Determine the best cooking mode for the type of food to be cooked.

START

Select from the following:

- **CONVECTION BAKE** - A combination of the convection fan and a bottom heat source. Good for single rack items in a deep pan.
- **CONVECTION BROIL** - A combination of the convection fan and a top heat source. Good for items that do not need to be flipped, such as thinner cuts of meat, fish, and garlic bread.
- **PURE CONVECTION™** - Uses convection cooking only for even heat. Use for baked goods and multiple rack cooking.
- **BAKE** - Cooks with a bottom heat source only. Commonly used for basic recipes.
- **BROIL** - Cooks using a top heat source alone. Use for grilling smaller cuts of meat or toasting bread.
- **CONVECTION ROAST** - Combines top and bottom heat sources with the convection fan. Best for rib roasts, turkeys, chickens, etc.

See pages 16 to 18 for detailed descriptions of the various cooking modes.



WARNING

In the interest of safety, keep the oven door completely shut when using the broil modes.

IMPORTANT: The broil modes will not work when the meat probe is connected.

1. Press the key for the desired cooking mode ①. The preset (jump-in) temperature will appear on the display (see page 15 for more details).
2. Press **START** ②, to cook at the preset temperature. Or you may enter a different cooking temperature (for example 3-5-0) on the number keypad ③, then press **START**.

You can enter any temperature between 100°F and 555°F. The suggested broil temperature is 555°F. On model ER48D the same **START** key is used to start both ovens.

If you are using one of the bake or roast modes, "**PRE-**" for pre-heating, along with the current oven temperature will appear on the display until the oven reaches the set temperature. Once the set temperature is reached, the oven will beep and "**PRE-**" will disappear from the display. Carefully place your food in the oven. Excessive browning will occur if you put the food in too soon.

Turning Off Your Oven

- To turn the oven off, press the **CANCEL-SECURE** key ④.

**CANCEL
SECURE**

NOTE: After you turn off the oven, the cooling fans may continue to run until the range's internal parts have cooled down.

Changing the Temperature

(after you press **START**)

1. Press the key for the current cooking mode. The current cooking mode appears on the display (for example **BAKE**).
2. Enter the temperature on the keypad (for example 3-7-5) and press **START**.

Changing the Oven Cooking Mode

(after you press **START**)

To change to a different cooking mode while the oven is on, for example to change from convection bake to bake:

1. Press the key for the new cooking mode, for example **BAKE**.
2. Press **START**.

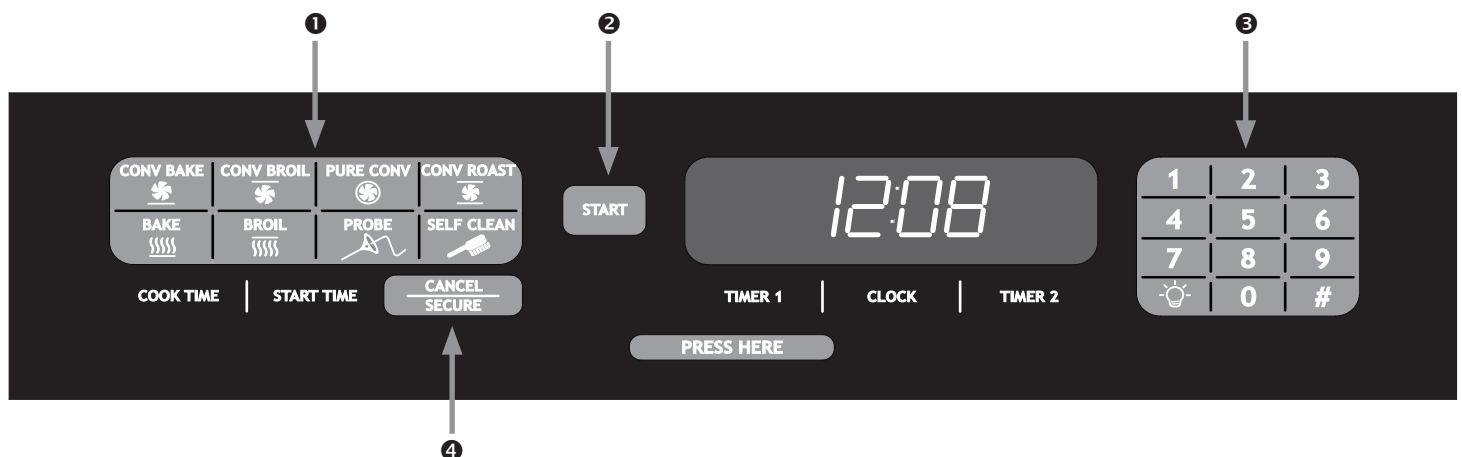

Operating the Oven

Preset (Jump-in) Temperature Settings

Your oven has a preset “jump-in” temperature setting for each of the cooking modes to reduce the need to always enter the temperature. See the table below. See **Starting Your Oven** on page 14 for directions on how to cook at the preset temperature.

Cooking Mode	Preset Temperature
Bake	350°F
Convection bake	325°F
Pure Convection	325°F
Convection roast	375°F
Broil	555°F
Convection broil	555°F

12 Hour Shut-off Feature

Your range is equipped with a feature that automatically turns the oven off after 12 hours of continuous use. The 12 hour shut-off time starts over again if you change the cooking temperature or cooking mode. This feature does not apply to the cooktop.

The range ships from the factory with the 12 hour shut-off enabled.

To disable or enable the 12 hour shut-off feature:

- With the oven off, push and hold the **TIMER 1** key **2** for about ten seconds, until the control panel beeps. “ON” will appear on the display if 12 hour shut-off is enabled.
- Push the **SELF CLEAN** key **3** to disable (or enable) the 12 hour shut-off feature.
- Push **START** **4** to save the changes and return to the clock display.

Turning the Control Panel “Beep” Off/On

The control panel beeps any time you press any of the keys or when various error conditions exist. It also beeps when a timer is done counting down (page 18) or whenever the oven performs certain preset functions, for example, pre-heat is complete. The tone may be silenced so that it does not function under the above conditions. To turn the control panel “beep” off (or on):

1. Press and hold the **START TIME** key **5** for six seconds, until “beep” appears on the display.
2. Press the **SELF CLEAN** key **3** repeatedly to switch between “On” and “Off”.
3. Press **CANCEL · SECURE** **1** when the desired mode appears on the display.

To change the control panel back to the previous mode, repeat the above steps.

Lock-Out Feature

If you want to disable the keys on the control panel when the oven is not in use:

- Push and hold the **CANCEL-SECURE** key **1** for about four seconds. The control panel keys will stop working and “OFF” will appear on the display. Only the **CANCEL-SECURE** and the oven light keys remain functional.
- To reactivate the control panel, press and hold the **CANCEL-SECURE** key for four seconds. On model ER48D, press either **CANCEL-SECURE** key to disable the control panel.

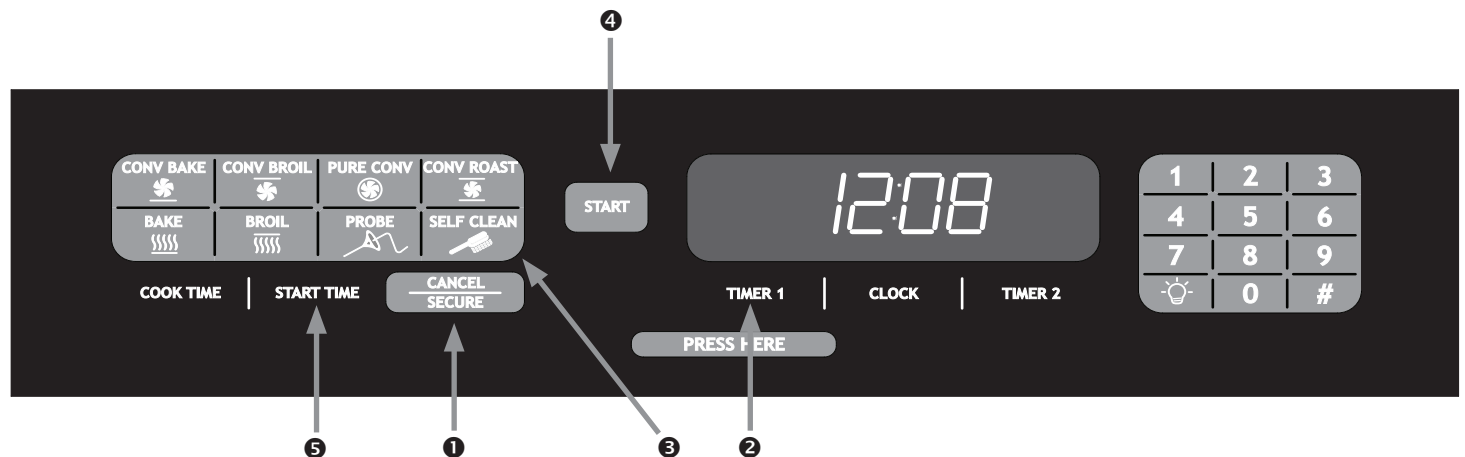

Operating the Oven

Understanding the Various Oven Modes

The three basic styles of cooking in an oven are:

- ❖ **BAKING** - The gentle cooking of dry goods such as cookies, cakes, soufflés, etc.
- ❖ **ROASTING** - The cooking of meats or vegetables over a period of time.
- ❖ **BROILING** - Cooking with an intense heat for a short amount of time.

Bake

Uses only a heat source from below the food. This mode is the stand-by, non-convection mode. All baked items will turn out nicely in this mode.



Baking Tips

- For best results, use a single rack in the lowest position when using bake mode. For cooking on multiple racks, Dacor recommends using one of the convection modes (See the following pages). Follow your recipe's original cooking time and temperature.
- Do not open the oven door frequently during baking. Look through the oven door window to check the progress of baking whenever possible.
- Use the timers to determine baking time.
- Use the lowest rack position.
- Wait until the shortest recommended baking time before checking the food. For most baked goods, a wooden toothpick placed in the center should come clean when the food is done.

Common Problems When Using Standard Bake Mode

Problem	May Be Caused By	What to Do
Cookies burn on the bottom.	Oven door opened too often.	Set timer to shortest recommended cooking time and check food when timer beeps. Use door window to check food.
	Incorrect rack position used.	Change rack position.
	Dark, heat absorbing cookie sheets used.	Use shiny, reflective cookie sheets.
Cookies are too brown on top.	Rack position being used is too high.	Change rack position.
	Food placed in oven during preheat.	Wait until oven is preheated.
	Incorrect baking mode being used	See " Select from... " section on page 14 for guidelines.
Cakes burn on the sides or are not done in the center.	Oven temperature too high.	Reduce oven temperature.
	Dark, heat absorbing cake pans used.	Use shiny, reflective cake pans.
Cakes crack on top.	Oven temperature too high.	Reduce oven temperature.
Cakes are not level.	Oven and/or oven rack not level.	Level oven and rack as needed.
Pies burn around the edges or are not done in the center.	Oven temperature too high.	Reduce oven temperature.
	Dark, heat absorbing pans used.	Use shiny, reflective pans.
	Oven and/or rack over-crowded.	Reduce number of pans.

Operating the Oven

The Three Convection Cooking Modes

- **Pure Convection**
- **Convection bake**
- **Convection roast**

As a general rule, in the convection modes time is about 25% shorter. Set the timer 15 minutes before the shortest stated time and add more time if necessary.

For Pure Convection and Convection Bake Modes:

Some recipes, especially those that are homemade, may require adjustment and testing when converting from standard to convection baking. If you are unsure how to convert a recipe, begin by preparing the recipe using the standard bake settings. After achieving acceptable results, follow the convection guidelines in the Dacor Cooking Guide. If the food is not cooked to your satisfaction during this first convection trial, adjust one recipe variable at a time (such as cooking time, rack position, or temperature) and repeat the convection test. If necessary, continue adjusting one recipe variable at a time until you get satisfactory results.

Pure Convection

The uniform air circulation provided by Pure Convection allows you to use more oven capacity at once. Use this mode for single rack baking, multiple rack baking, roasting and preparation of complete meals. Many foods, such as pizzas, cakes, cookies, biscuits, muffins, rolls and frozen convenience foods can be successfully prepared on two or three racks at a time. Pure Convection is also good for whole roasted duck, lamb shoulder and short leg of lamb.

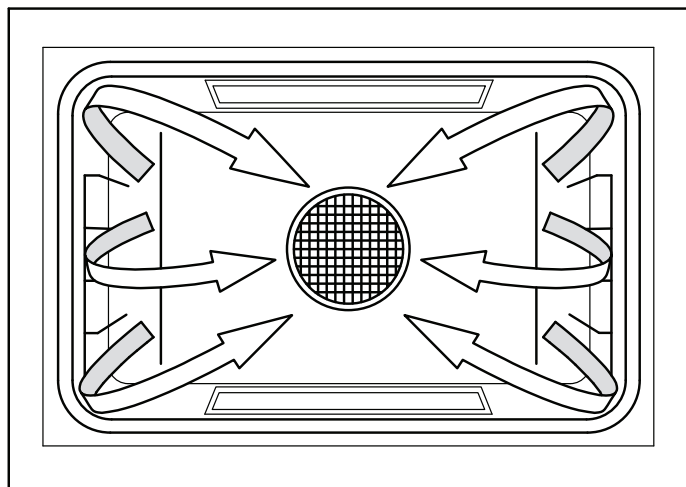

For Multiple Rack Baking:

Typically, when baking on two racks, use rack positions #1 and #3 or #2 and #4 (counting from the bottom up). When adapting a single rack recipe to multiple rack baking, it may be necessary to add to the baking time due to the extra bulk of the food in the oven.

Convection Bake



Use this mode for single rack baking. The combination of the convection fan and bottom heat source is best for fruit crisps, custard pies, double-crust fruit pies, quiches, yeast breads in a loaf pan and popovers. Also, items baked in a deep ceramic dish or earthenware clay pots are best in this mode. Most of these items cook in a deep pan and require browning on the top and bottom.

Convection Roast



Your range's convection roast mode uses a combination of the convection fan and heat sources above and below the food. Best for rib roasts, turkeys, chickens, etc.

Roasting Tips

All baking modes can be used to successfully roast in your oven. However, the convection roast mode is recommended to produce meats that are deliciously seared on the outside and succulently juicy on the inside in record time. Foods that are exceptional, when prepared in the convection roast mode, include: beef, pork, ham, lamb, turkey, chicken and cornish hens.

Always roast meats fat side up in a shallow pan, using a roasting rack. Always use a pan that fits the size of the food being prepared. The broiler pan and grill, accompanying the oven, can be used in most cases. No basting is required when the fat side is up. Do not add water to the pan. It will cause a steamed effect. Roasting is a dry heat process.

Poultry should be placed breast side up on a rack in a shallow pan that fits the size of the food. Again, the broiler pan and grill accompanying the oven can be used. Brush poultry with melted butter, margarine, or oil before and during roasting.

When using the roast mode, do not use pans with tall sides. They interfere with the circulation of heated air over the food.

If using a meat thermometer, insert the probe halfway into the center of the thickest portion of the meat. For poultry, insert the thermometer probe between the body and leg into the thickest part of the inner thigh. To ensure an accurate reading, the tip of the probe should not touch bone, fat or gristle. Check the meat temperature $\frac{2}{3}$ of the way through the recommended roasting time. After reading the meat thermometer once, insert it $\frac{1}{2}$ inch further into the meat, then take a second reading. If the second temperature registers below the first, continue cooking the meat.

Remove meats from the oven when the thermometer registers 5 to 10°F below the desired temperature. The meat will continue to carry-over.

Allow roasts to stand 15 to 20 minutes after roasting in order to make carving easier.

Roasting times always vary according to the size, shape and quality of meats and poultry. Less tender cuts of meat are best prepared in bake and may require moist cooking techniques. Follow your favorite cookbook recipes.

Reduce spatter by lining the bottom of the roasting pan with lightly crushed aluminum foil.

Operating the Oven

Understanding the Various Oven Modes (continued)

The Two Broil Modes

- **Broil**
- **Convection broil**

Broiling is a quick and flavorful way to prepare many foods, including steaks, chicken, chops, hamburgers, and fish. In the interest of safety, keep the oven door completely shut when using the broil modes.

CAUTION

To avoid damage to the meat probe, remove it from the oven when using either of the broil modes. It can be damaged by temperatures above 450°F.

Convection Broil



This mode uses a combination of the convection fan and a top heat source. It is best for items that do not need to be flipped such as, thinner cuts of meat, fish and garlic bread.

Broil



Uses a top heat source. Best for broiling smaller amounts of food.

Broiling Tips

If the meat probe is plugged into the oven, disconnect and remove it before selecting one of the broil modes. The broil modes do not function with the meat probe connected.

It is normal and necessary for some smoke to be present to give the food a broiled flavor.

Setting the timer is recommended to time the broiling process.

Always use a broiler pan and grill to provide drainage for excess fat and grease. Doing so will reduce spatter, smoke and flare-ups.

Start with a room temperature broiler pan for even cooking.

Use tongs or a spatula to turn and remove meats. Never pierce meat with a fork because the natural juices will escape.

Broil food on the first side for a little more than half of the recommended time, then season and turn. Season the second side just before removing the food from the oven.

To prevent sticking, lightly grease the broiler grill. Excess grease will result in heavy smoke. For easier cleaning, remove the broiler pan and grill when the food is removed.

Timers

WARNING

The timers on your range do not turn the oven on or off. They are only for timing purposes. When you want to turn the oven off automatically, use the *Delay Timed Cooking Features* (see page 19).

IMPORTANT: Pressing the **CANCEL-SECURE** key does NOT turn off the timers.

Your range is equipped with 2 built-in timers:

- You can use both of them at the same time.
- You can time from 1 minute up to 11 hours and 59 minutes.

To use the timers on your range:

1. Press the **TIMER 1** or **TIMER 2** key.
2. Enter the hours and minutes to be timed on the keypad and press **START**. To enter 11 hours, 30 minutes, press 1-1-3-0. To time 25 minutes, press 2-5. When you press **START**, the time will appear on the display and will begin to count down.

The alarm (a beeping sound) will go off when the timer is done counting down. Timer 1 and Timer 2 have different beeping patterns so you can easily tell which one has gone off. There is also a special beeping pattern when both alarms go off at the same time.

Timer	Alarm Pattern
1	1 second on, 1 second off, repeat
2	1 second on, 1 second off, 2 seconds on, 1 second off, repeat
1 and 2	2 seconds on, 1 second off, repeat

Press the **TIMER 1** (or **TIMER 2**) key to stop the alarm.

While a timer is running you can:

- Press **CLOCK** to view the current time.
- Press **TIMER 1** to view the time left on (or set) **TIMER 1**.
- Press **TIMER 2** to view the time left on (or set) **TIMER 2**.

To change the amount of time on a timer:

1. Press the **TIMER 1** or **TIMER 2** key.
2. Enter the new time on the keypad and press **START**.

To stop a timer before time runs out:

1. Press the **TIMER 1** or **TIMER 2** key twice.
2. The timer will stop and the display will read 0:00.

Operating the Oven

Delay Timed Cooking Features

If you want to set the oven to automatically turn itself on or off at a later time, you can use the delay timed features.

Things to Know About Delay Timed Cooking

- The delay timed options work for all of the various cook modes, except broil and convection broil.
- You may use the timers while using the delay timed features. The timers do not have an effect on any of the delay timed cooking options.
- The delay timed cycle can be canceled at any time by pushing **CANCEL-SECURE**.



WARNING

Food safety is an important consideration when using the delay timed features. To avoid potential sickness and the spoiling of food, take the following steps:

- Avoid using foods that will spoil while waiting for the oven to start cooking. Typical foods to avoid include: those containing eggs and dairy products, cream soups and cooked or uncooked meats, poultry and fish.
- Do not allow foods to remain in the oven after it turns completely off (after hold mode.) When the temperature drops below 140°F, bacteria can develop.
- If cooking will not begin immediately, place only very cold or frozen food into the oven. Most unfrozen foods should never stand in the oven for more than two hours before cooking begins.

Delay Timed Cooking Set-up

Before setting the controls:

- Adjust the racks to the appropriate level.
- Put the food in the oven.

The Three Ways to Use Delayed Timed Cooking

1. Set the time the oven turns on (**START TIME**) and the amount of time it cooks (**COOK TIME**) before going into hold mode.
2. Set the **START TIME** only, then turn the oven off manually when you are done cooking.
3. Turn the oven on manually, then set the amount of **COOK TIME**. The oven will go into hold mode after the time expires.

To set both the start and cook times:

1. Press the key for the desired cooking mode (except the broil modes).
2. Enter the desired cooking temperature on the number keypad and press **START**.
3. Press the **START TIME** key.
4. Enter the time you want the oven to start on the keypad and press **START**. For 12:35, press 1-2-3-5. You may enter a time up to 11 hours and 59 minutes ahead of the present time.
5. Press the **COOK TIME** key.

6. Enter the amount of time you want the oven to be on (after it starts), using the keypad and press **START**. For 1 hour and 35 minutes, press 1-3-5. For 25 minutes, press 2-5. You may enter from 1 minute up to 11 hours and 59 minutes.
7. The oven will start at the start time entered, cook for the amount of cook time entered and then, go into hold mode.

IMPORTANT: The time required to preheat the oven must be included in the cook time. For cooking temperatures 350°F and below, add 13 minutes to the cook time. Increase the cook time as the temperature increases above 350°F.

To set the start time only:

1. Press the key for the desired cooking mode (except the broil modes).
2. Enter the desired cooking temperature on the number keypad and press **START**.
3. Press the **START TIME** key.
4. Enter the time you want the oven to start on the keypad and press **START**. For 12:35, press 1-2-3-5. You may enter a time up to 11 hours and 59 minutes ahead of the present time.
5. The oven will start at the start time entered. Since you did not enter a cook time, you must turn the oven off manually by pressing **CANCEL-SECURE**.

To set the cook time only:

1. Press the key for the desired cooking mode (except the broil modes).
2. Enter the desired cooking temperature on the number keypad and press **START**. The oven will turn on.
3. Press the **COOK TIME** key.
4. Enter the amount of time you want the oven to be on, using the keypad and press **START**. For 1 hour and 35 minutes, press 1-3-5. For 25 minutes, press 2-5. You may enter from 1 minute up to 11 hours and 59 minutes.
5. The oven will cook for the amount of time entered and then, go into hold mode.

Other Things to Know About Delayed Timed Cooking

When the oven is in delay timed mode...

- Push the **CLOCK** key to view the time.
- Push the **START TIME** key to view the current start time setting.
- Push the **COOK TIME** key to view the current cook time setting.

Hold Mode

- When the oven reaches the end of the cook time you have set, it will go into "hold" mode (**HLD** appears on the display.) The oven will keep the temperature at 150°F for two hours.
- Press **CANCEL-SECURE** to turn the oven off.
- To prevent sickness, do not allow foods to remain in the oven after it is off (after hold mode turns off).

Operating the Oven

Using the Meat Probe

When you cook foods like roasts and poultry, the internal temperature is the best way to tell when the food is properly cooked. Your oven's meat probe is an easy way to take the guesswork out of roasting. You can use it to cook food to the exact temperature you desire. The probe can be set from 100°F to 200°F.

NOTE: The meat probe does not work with the **BROIL** or **CONVECTION BROIL** modes.



WARNING

- To avoid the possibility of burns, use hot pads to handle, connect, and unplug the meat probe when the oven is hot.
- Use the handles to insert and remove the meat probe's skewer and to connect it to the oven. Pushing or pulling on either end of the cable could damage the meat probe.
- To avoid breaking the meat probe, make sure the food is completely defrosted before inserting the skewer.
- Never store the meat probe inside the oven, especially during the self clean cycle.
- Use of meat probes other than the one provided with your range may result in damage to the meat probe and/or the oven.

To use the meat probe:

1. Prepare the meat for cooking prior to setting the oven. Insert the meat probe skewer into the center of the meat. Make sure that the skewer is not inside any fatty portions of the meat and does not touch any bones. The point should rest in the thickest part of the meat. When you are cooking fowl, the tip of the skewer should rest toward the center of the bird.
2. Before putting the meat in the oven, close the door and push the **BAKE, CONVECTION BAKE, PURE CONVECTION** or **CONVECTION ROAST** key. The preset temperature will appear on the display. If you want to cook using a different oven temperature, enter it on the keypad.
3. Press **START**.
4. Allow the oven to preheat.
5. Once the oven has preheated, put the meat in the oven using potholders. Plug the meat probe into the connector inside the oven.
6. Push the **PROBE** key. The preset temperature (160°F) will appear on the display.

7. If you want to cook using a different probe temperature, enter it on the keypad. Use the USDA **Minimum Safe Cooking Temperature Chart** on the facing page as a guideline for the type of meat you are cooking.
8. Press **START**. If you do not press **START**, the probe mode will start automatically after six seconds.

When the meat probe is in use, the oven will automatically control the cooking time. The temperature on the display during cooking is the temperature measured inside the meat. The oven will continue to cook until the meat temperature reaches the temperature you have entered.

When the meat is done, the oven will go into hold mode. The temperature will reduce to 150°F for two hours to keep the meat warm and safe for serving. To prevent sickness, do not allow foods to remain in the oven after it has turned off. Press **CANCEL-SECURE** to cancel hold mode and turn the oven completely off.

To change the meat probe temperature during cooking:

1. Press **PROBE**. The current probe temperature will appear on the display.
2. Enter the new temperature. The oven will automatically change to the new probe temperature. If you do not enter a temperature, the oven will continue to cook at the current setting.

To change the cooking mode during meat probe cooking:

1. Press the key for the new desired cooking mode (**BAKE, CONVECTION BAKE, PURE CONVECTION** or **CONVECTION ROAST**).
2. You may enter a new temperature on the keypad or use the default temperature.
3. Push **START**. The oven will cook until the meat's internal temperature reaches the previously selected meat probe temperature.

To cancel meat probe operation while the oven is cooking:

- Press the **PROBE** key twice. Disconnect the meat probe from the connector. If you do not disconnect the meat probe, an error tone will sound. The oven will return to any previous settings that were entered before the **PROBE** key was pressed.

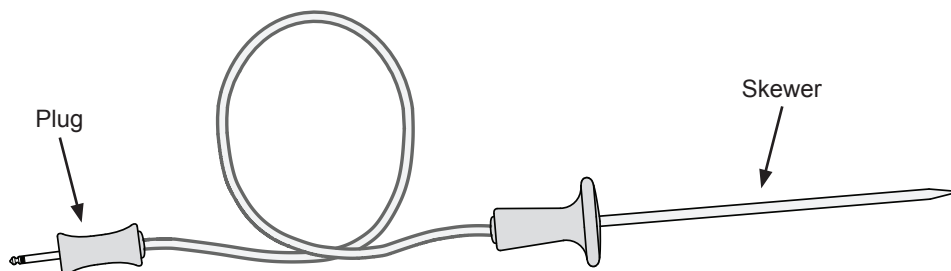

Meat Probe

Operating the Oven

Important Details About the Meat Probe

- You must select the specific cooking mode (**BAKE, CONVECTION BAKE, PURE CONVECTION** or **CONVECTION ROAST**) before you press the **PROBE** key.
- There is no preheat cycle when the meat probe feature is used. For best results, select the mode and allow the oven to preheat prior to starting the meat probe feature.
- The meat probe cannot be used with the broil modes. An error tone will sound.
- If you disconnect the meat probe from the oven during cooking, probe mode will cancel. The oven will continue to cook until you press **CANCEL-SECURE**.
- If you leave the meat probe plugged into the oven, but the meat probe feature is not selected on the control panel, "**PRB**" will flash on the screen.
- The meat probe function will automatically cancel after 30 seconds if the meat probe is not connected. "**PRB**" will flash on the display.
- The meat probe feature takes precedence over the delay timed cooking feature. Delay timed cooking does not work when the meat probe is in use. The oven will continue to cook the meat until it reaches the selected meat probe temperature. However, if delay timed cooking was selected before the **PROBE** key was pressed, the oven will shut off instead of going into hold mode.

USDA Minimum Safe Internal Cooking Temperatures

GROUND MEAT AND MEAT MIXTURES	
Beef, pork veal, lamb	160°F
Turkey, chicken	165°F
FRESH BEEF, VEAL, AND LAMB	
Medium rare	145°F
Medium	165°F
Well Done	170°F
POULTRY	
Chicken/turkey, whole (temp taken in thigh)	180°F
Poultry breasts, roast	170°F
Poultry thighs, wings, legs	180°F
Duck and goose	180°F
Stuffing	165°F
FRESH PORK	
Medium	160°F
Well done	170°F
HAM	
Fresh (raw)	160°F
Pre-cooked (reheat)	140°F

NOTE: The minimum safe internal cooking temperatures are subject to change. There are changes in bacteria and the temperatures required to eradicate them. For the most current information, contact the USDA.

USDA Meat and Poultry Hot-line:
Phone: (800) 535-4355
www.fsis.usda.gov

Dehydrating/Defrosting

Your range can be used to dehydrate or defrost foods at low heat settings in the Pure Convection mode.

WARNING

To avoid food poisoning, cook meats immediately after defrosting them.

To dehydrate or defrost foods:

- Adjust the racks to the appropriate level.
- Place the food on the center of the oven rack. (If you are dehydrating, prepare food as recommended, then place it on a drying rack).
- Press the **PURE CONVECTION** key.
- To defrost meats, enter the temperature up to 150°F on the keypad. To dehydrate, start by setting the temperature according to the table below. When dehydrating, you may need to experiment with higher temperatures.
- Press **START**.

Food Type	Dehydrating Temperature
Fruit	100°F
Vegetables	125°F
Meat	150°F

Dacor recommends that you use one of the timers to time the process.

Dehydrating Tips

Equipment Recommended:

- Half sheet pan or jelly roll pan with ½" rim all the way around
- Baking rack that fits inside the half sheet pan
- Cheesecloth
- 4 quart sauce pot with lid
- Steamer basket that fits inside 4 quart saucepan. One that is perforated and opens up will work well.
- Slotted spoon
- Paper towels
- A sharp knife

When you dehydrate:

- Wash and remove excess moisture from all fruits and vegetables before dehydrating.
- Cut fruits and vegetables into uniform pieces.
- You can add honey, spices, lime juice or orange juice to give the fruit a different flavor.
- It is best to dehydrate on a baking rack with a pan underneath to catch any juices. If the fruit is small, use cheesecloth over the rack. If you use a rack, it will allow for maximum air circulation around the fruit. The cheesecloth will prevent the fruit from sticking to the rack.
- Place the food onto the center of the oven rack.

continued...

Operating the Oven

Dehydrating Tips (continued)

Solving Discoloration Problems

To prevent darkening during dehydration and storage, you should steam blanch apples, apricots, peaches, nectarines, pears or foods that will oxidize.

To steam blanch:

1. Add 1 inch of water to a 4 quart sauce pot. Insert the steam basket and place the fruit in it.
2. Cover the pot and steam for 1 to 2 minutes.
3. Remove with a slotted spoon and dab with a paper towel to remove excess moisture before dehydrating.

Apples, pears, pineapples and some other fruits will brown or darken during dehydration. To prevent discoloration, dip fruits in pineapple juice or lemon juice after steam blanching.

Creating a Candied Effect

To give fruit a candied effect and to help retain color, blanch them in a simple syrup. You can candy the fruits mentioned above as well as figs and plums. The basic ratio for a simple syrup is 1 cup of sugar to 1 cup of water. Add these ingredients to a 4 quart stock pot and bring to a boil. Stir until all the sugar dissolves. Remove the saucepan from the cooktop and allow it to cool. Dip fruit into the simple syrup after it has cooled.

Preventing Tough Skins

You should water blanch items with tough skins such as grapes, prunes, dark plums, cherries, figs, and some types of berries. Water blanching these types of fruit will crack the skins so that moisture can escape and dehydration can be done more effectively.

To water blanch:

1. Bring 2 quarts of water to boil in a 4 quart sauce pot.
2. Drop the fruit in the water for 1 to 2 minutes, or until the skin begins to crack.
3. Remove the fruit with a slotted spoon and dab dry with a paper towel before dehydrating. The pit can be left inside or removed half way through the dehydrating process.

Defrosting Tips

- Food that takes an exceptional amount of time to defrost will not defrost well in a convection oven.
- You should not defrost anything that would normally take over 2 hours to thaw. The food will begin to spoil because the defrost temperature is not high enough to cook the food.
- If you have a partially defrosted turkey, rib roast or other large cut of meat, you may continue to defrost it in your convection oven. If wing tips and legs begin to dry out when you defrost poultry, you may wrap the tips with aluminum foil.
- If you are defrosting a small cut of meat, lay it on a flat cookie sheet with a 1 inch rim to catch juices as the meat thaws.
- Thick, frozen casseroles such as lasagna will not defrost well in your oven. Instead, defrost according to the food manufacturer's suggestions. You may also defrost casseroles in the refrigerator overnight. You should leave the food in its original container and keep it covered.
- You can bake some foods from frozen. Some examples are: pizza, frozen pastries, croissants, cookies, etc. Before baking frozen food, allow the oven to preheat.

Proofing

You can use your range to proof yeasted doughs at a low and draft-free temperature using the bake mode.

1. Press the **BAKE** key.
2. Enter the temperature of 100°F on the keypad.
3. Press **START**.
4. Place the dough in a greased bowl inside of the oven. Cover it with either a damp cloth or plastic wrap coated with a non-stick spray.
5. Turn on the oven lights.
6. Set the timer for the amount of rise time in the recipe.

Information About Operation on Sabbath and Jewish Holidays

For Sabbath and other Jewish holidays, use the delay start (**START TIME**) feature with the 12 hour shut-off feature disabled and the control panel beep turned off.

- Turning off the 12 hour shut-off feature allows the oven to be used continuously without it shutting off automatically. See page 15.
- Turning off the control panel "beep" prevents the control panel from emitting a beep when you press the control panel buttons. See page 15.
- Place the food in the oven in advance and use only the **START TIME** feature (See **Delay Timed Cooking** on page 19) to start the oven. Other oven modes (including the meat probe and the timers) are not considered Sabbath compliant.

Please visit www.star-k.org for further information about Sabbath compliance and usage of this product.

Cooking Tips

Food Placement

NOTE: The rack positions mentioned below are counting from the bottom up.

- Typically, when baking on 2 racks, use rack positions #2 and #4 or #1 and #3. When baking on 3 racks, use rack positions #1, #3 and #5.
- Turn pans on the racks so that the long sides run left to right, as you face them.
- When you are cooking a food item that is very heavy, use a Dacor GlideRack oven rack. You can pull it out further than a conventional rack, making it easier to check the food, stir or add ingredients.
- Heavier roasting pans and dishes will cook better on rack position #1.
- When using the optional baking stone, use rack position #1 for best results. If you put a baking stone on a GlideRack oven rack, instead of one of the standard oven racks, you can pull the stone out of the oven further, making pizza easier to remove.

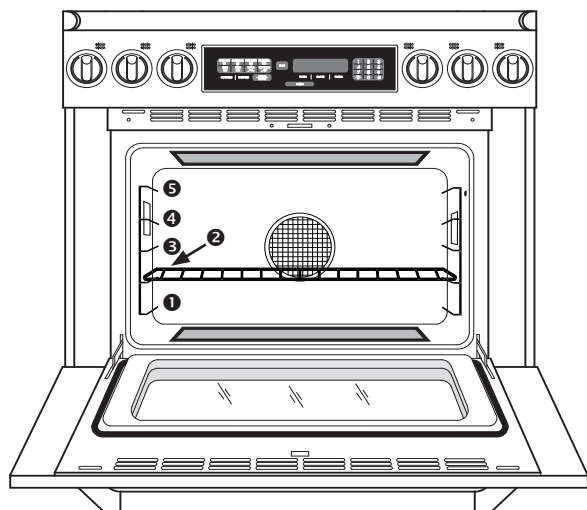

Oven Rack Positions

The Best Use of Bake Ware

- You should bake cakes, quick breads, muffins and cookies in shiny, reflective pans for light, golden crusts. Avoid old, darkened, warped, dented, stainless steel and tin-coated pans. They heat unevenly and will not give good baking results.
- Use medium gauge aluminum sheets with low sides when preparing cookies, biscuits and cream puffs. Dacor cookie sheets, with their low profiles, will give you the best results.
- Bake most frozen foods in their original foil containers, placed flat on a cookie sheet. Follow the package recommendations. When using glass bake ware, reduce the recipe temperature by 25°F, except when baking pies or yeast breads. Follow the standard recipe baking time for pies and yeast breads.
- Use the pan size and type recommended by the recipe for best results.

- For roasting, Dacor's optional "V" shaped rack and broil/roast pan works best to allow air circulation around the food. Dacor's roasting pan works particularly well and two of them will fit side by side in a 30 inch oven.

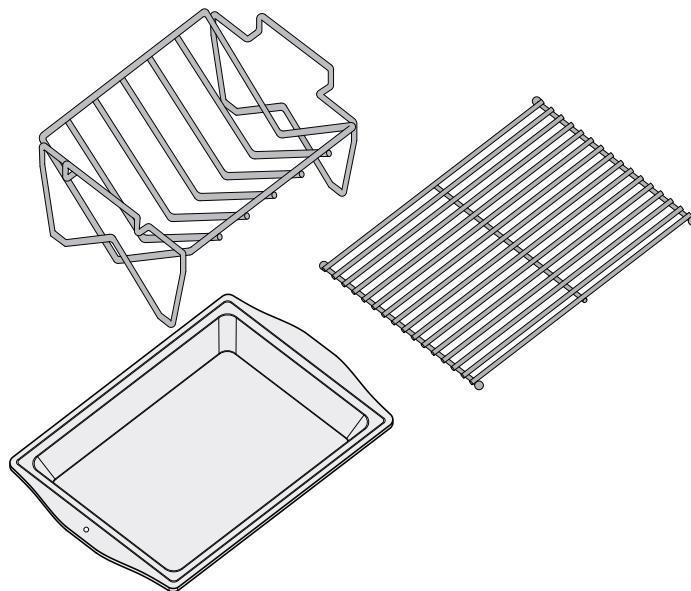

High Altitude Cooking

Due to the lower atmospheric pressure at higher altitudes, foods tend to take longer to cook. Therefore, recipe adjustments should be made in some cases. In general, no recipe adjustment is necessary for yeast-risen baked goods, although allowing the dough or batter to rise twice before the final pan rising develops a better flavor. Try making the adjustments below for successful recipes. Take note of the changes that work best and mark your recipes accordingly. You may also consult a cookbook on high altitude cooking for specific recommendations.

Altitude (feet)	Baking Powder for each teaspoon decrease by:	Sugar for each teaspoon decrease by:	Liquid, for each cup add:
3000	5-10%	10-25%	5-10%
5000	10%	10%	20%
7000	25%	20%	20-25%

Care and Cleaning

WARNING

- Clean only the parts of the range listed in this manual. Clean them only in the manner specified.
- To avoid dangerous fumes or damage to your range's surfaces and accessories, use only the types of cleaning solutions specified in this manual.
- To avoid electrical shock or burns, turn off the burners and the oven(s). Make sure all parts are cool before cleaning.
- To prevent damage, do not use abrasive or corrosive cleaners or applicators such as steel wool or scouring pads, on any part of the range unless instructed to do so. Use only a sponge, soft cloth, fibrous or plastic brush, or nylon cleaning pad for cleaning the surfaces of your range.
- Do not use a steam cleaner to clean the range. Steam could penetrate the electrical components and cause a short circuit.
- Do not try to force the door open after it is locked. Damage to the door or latch may result.
- Do not try to remove heavy spills with a sharp object such as a knife or metal spatula. Sharp objects may scratch your range's surfaces.
- Always wipe up excess grease and other food spills with a damp cloth prior to using the self clean cycle. Doing so will minimize smoke and increase efficiency. See proper cleaning instructions on this page.
- Do not touch the outside surfaces of the oven during the self clean cycle. They will be hot.
- **CAUTION: DO NOT LEAVE FOOD, COOKING UTENSILS, OVEN RACKS, THE CONVECTION FILTER, ETC., IN THE OVEN DURING THE SELF-CLEAN CYCLE.**
- **ATTENTION : NE LAISSER AUCUN ALIMENT, UTENSILE DE CUISINE, GRILLES DU FOUR, LE FILTRE DE CONVECTION, ETC., DANS LE FOUR DURANT LE CYCLE D'AUTONETTOYAGE.**
- Ensure that the anti-tip bracket is engaged after the range is moved out for cleaning. Use a flashlight to look underneath the range and verify that the anti-tip bracket covers the anti-tip foot when the range is moved back into place.

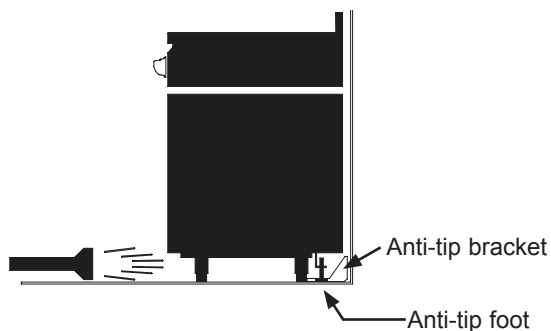

Your Oven's Self Clean Feature

About the Self Clean Cycle

- The oven will run better and produce better baked goods when it is clean. During self cleaning, the oven is heated to very high temperatures which burn off any deposits on the surfaces of the oven. Self cleaning eliminates the need for manual scrubbing of interior surfaces. The self clean process takes about three hours.

- It is normal for the oven to emit smoke during the first few self clean cycles. It is also normal for the oven to emit popping sounds during self cleaning. These sounds are caused by the expansion and contraction of metal surfaces when the oven heats up and cools down.
- Self clean mode will not function if the meat probe is connected.

How to Use the Self Clean Feature

IMPORTANT: On model ER48D: The control panel will only allow one oven chamber to be self cleaned at a time due to the amount of power consumed. Also, model ER48D range's computer will not allow you to cook in one oven while the other is in self clean mode.

1. Before self cleaning the oven, remove the racks, the convection filter, all cookware (pots, pans, forks, etc.), the meat probe, foil and any other loose objects from the oven chamber. See page 27 for instructions on how to remove and clean the filter.
2. Clean soil from the porcelain surfaces of the door outside of the door gasket. Rinse surfaces well with a solution of vinegar and water, then wipe dry. Heavily soiled areas may be cleaned with a non-scratching scouring pad.
3. Clean the door gasket by dabbing it with a solution of water and mild soap.

WARNING

Take extreme caution when cleaning the door gasket. Rubbing or displacing it may damage the tight door seal required for proper cooking and self cleaning.

4. Turn on kitchen fans or vents to help remove odors during the self clean cycle.
5. Make sure the oven door is shut.
6. Press the **SELF CLEAN** key.
7. Press **START**.



The control panel automatically locks the oven door during self cleaning. The latch prevents the door from being opened since the high interior oven temperatures can easily cause injury. If the door is not shut, "**DOOR**" will appear on the display. To correct the problem, press **CANCEL-SECURE** and wait approximately one minute, then close the door. When the door is properly closed, start the self clean process again.

The display shows the self clean cycle status:

- "**CLEAN**" indicates that self clean is in process.
- "**LOCK**" indicates that the door is latched.
- "**ON**" indicates that the heating elements are on.

On model ER48D, "**OVEN 1**" (left oven) or "**OVEN 2**" (right oven) will appear on the display indicating the oven is in self clean.

If you want to stop the self clean cycle, press the **CANCEL-SECURE** key. Keep in mind that the oven door will remain locked until it is safe enough to open. "**LOCK**" will disappear from the display when the door lock is released. You will still need to exercise caution when the door lock is released because the inside of the oven may still be hot.

Care and Cleaning

After the Self Clean Cycle is Complete

- The door latch will release when the inside has cooled down. The words "**CLEAN**", "**LOCK**" and "**ON**" will disappear from the display. Exercise caution because the oven will still be hot (about 400°F) at the time the door lock is released.
- Reinstall the convection filter and oven racks before using your oven.
- You may notice a powder ash residue in the bottom of the oven after self cleaning. This is normal. Use a damp cloth or sponge to wipe up the residue after the oven cools down.

Self Cleaning Tips

- If any soil remains in the oven after the self clean cycle is done, you may repeat the cycle if you want.
- Self clean the oven regularly to prevent excessive soil build-up. Doing so will make the self clean cycle work better and reduce smoke and odors.

Setting the Oven To Self Clean At a Later Time

1. Prepare the oven for self cleaning as instructed on page 24. Observe all safety precautions and remove all items listed from inside the oven. Clean the door gasket and around the door as instructed.
2. Close the oven door.
3. Press the **START TIME** key.
4. Enter the desired start time. For example, press 1-2-3-0 for 12:30. You may enter a time up to 11 hours and 59 minutes ahead of the present time.
5. Press **START**.

6. Press the **SELF CLEAN** key.
7. Press **START**.
8. When you press **START**, "**Delay**" will appear on the display and the oven door will lock. The oven will start to self clean at the time you have selected.



Display When Self Clean Delay is ON

NOTES:

- If you want the display to return to the clock, you may push the **CLOCK** key.
- If the clock is showing on the display, you may push the **START TIME** key to check the self clean start time.
- When self clean starts, "**Delay**" will disappear and "**ON**" will appear on the display.

To cancel the time delayed self clean cycle:

- Press **CANCEL-SECURE**.
- If the self clean process has not started, allow about a minute for the door to unlock before attempting to use the oven.
- If the oven is in the middle of the self clean process, the door will unlock when the oven has cooled down enough to open safely. The oven will still be hot.

General Cleaning

CAUTION

Use only a sponge, soft cloth, fibrous or plastic brush, or nylon pad for cleaning the surfaces of your range. Avoid the use of abrasive cleaners such as steel wool.

Knobs and Trim Rings

CAUTION

- Do not soak the knobs in water or put them in the dishwasher.
- Do not remove the trim rings from the range. Clean only the outside edges of the trim rings. If you get moisture inside the trim rings, damage to the knob lights or other parts of the range can occur.
- Installing the range knobs in the wrong position may result in damage to the griddle included with the range. The knobs for the center burners are marked with the maximum griddle settings.
- To prevent damage, do not use abrasive or corrosive cleaners or applicators.

- Wash the knobs regularly with a solution of warm soapy water. Dacor recommends hand dishwashing liquid.
- Turn the knobs to the off position to remove them for cleaning or replacement.
- Grasp each knob and pull straight back, off of the valve shaft.
- Clean the outside edges of the trim rings while the knobs are removed. Wipe them with a soft damp rag.
- To replace the knobs, align the "D" shaped opening on the back of the knob with the end of the valve shaft. Carefully push the knob on until it stops. Make sure you put the two knobs with the words "**MAX GRIDDLE**" on the center burner valve stems (closest to the control panel).

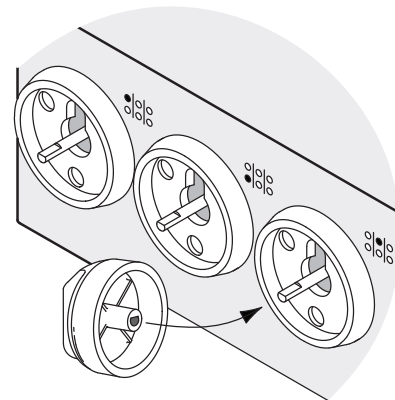

Care and Cleaning

General Cleaning (continued)

Cleaning the Cooktop

CAUTION

- After cleaning the burners, reassemble all of the burner parts before attempting to operate the cooktop.
- Always dry the cooktop parts completely before use.
- Do not clean the cooktop grates, burner parts or WOK ring in a dishwasher. They will be damaged.
- Use care while cleaning the igniters. The porcelain is fragile and can crack or break.

To keep the cooktop looking and operating its best, clean it after every use. Also, quickly wipe up spills that occur while cooking. Be careful not to touch any hot areas. Spills that remain on hot burner parts will be very difficult to clean, especially if allowed to burn on. Certain types of food, such as tomatoes, citrus juices, vinegar, alcohol and milk can damage the finishes if you allow them to stand for any length of time.

IMPORTANT: The cooktop is exposed to extremely high temperatures. The grates are put under a lot of stress when hot utensils are placed on them. In addition, the cooktop parts are occasionally exposed to acidic food spill-overs. These severe operating conditions, cause the porcelain enamel parts on your cooktop to undergo a change in appearance over time. If you care for and clean these parts carefully, you will slow down, but not eliminate, the aging process.

Cooktop Disassembly

- When the cooktop is cool, remove the grates from the top of the range.
- Lift the burner caps and burner rings off of the burners. Remove the burner heads from the crown burners.

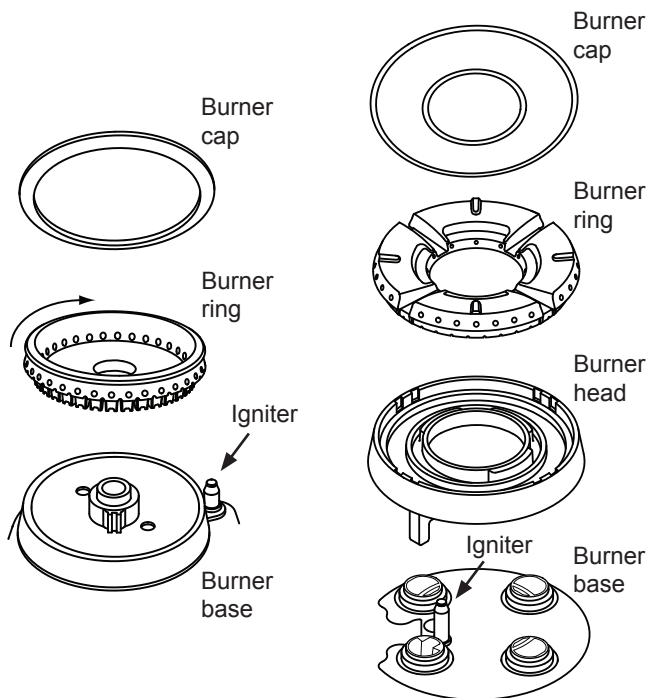

Stack Burner Parts

Crown Burner Parts

Cleaning the Grates, Spill Trays and WOK Ring

- The grates, spill tray and WOK ring are coated with a porcelain finish. For everyday cleaning, use a soft cloth or non-abrasive pad with warm soapy water to clean all of the porcelain parts.
- If necessary, tough stains may be removed by applying full strength sprays such as Simple Green, Ajax All-Purpose Cleaner or Formula 409. To minimize wear, use the mildest cleaner needed to get the surface clean.
- For extremely stubborn stains, you may use a mildly abrasive cleaner or applicator, such as Soft Scrub, Bon Ami, S.O.S. pads or other soap-filled steel wool pads. **Use these cleaners with extreme care and only on occasion.** Aggressive or extensive use of these types of abrasives will damage the finish. **Finish damage due to the use of abrasives is not covered under your warranty.**

Cleaning the Burner Components and Igniters

IMPORTANT: The igniter will not work properly if the burner cap, burner ring, burner base or the igniter itself are not clean. Dirty or wet igniters may not spark at all.

1. After disassembling the burners, check for any dirt or grime deposited on the individual parts, including the igniters.
2. Use a firm tooth brush to gently clean completely around the igniter, including all of the metal top and porcelain base. Do not use water to clean the igniters. If necessary, use a small amount of rubbing alcohol to help dissolve grime.
3. Examine the burner rings. Remove anything stuck in the holes with a straightened paper clip, wire or needle. Be careful not to scratch or damage the ring and cap. Do not distort the shape of the burner ring holes.
4. Clean all the burner parts, including the burner bases, with window cleaner or rubbing alcohol. Use a cleaning brush with plastic bristles or a firm tooth brush. When done, rinse the parts well with clean water. Dry all the parts thoroughly before re-assembling them.
5. Reassemble the cooktop according to the burner and grate assembly instructions starting on page 8. Test the burners after reassembling them. If the flame is uneven, be sure that the brass burner ring and porcelain burner cap are properly positioned, then check for any remaining dirt or grime on the burner parts or igniter. If erratic clicking is still present, make sure the igniter is completely dry. If the unit still exhibits problems after drying, call your local Dacor Authorized Service Agent.

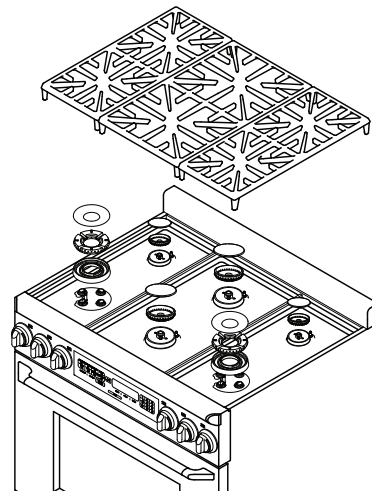

Care and Cleaning

Cleaning the Control Panel

CAUTION

Do not use abrasive cleaners or scrubbers on the control panel. They will permanently damage the finish.

To avoid accidentally turning the oven on while cleaning the control panel, activate the lock-out feature. Press the **CANCEL-SECURE** key for four seconds. The lock-out feature disables the keys. When the control panel is locked, the word "OFF" appears on the display.



When you want to re-activate the control panel, press **CANCEL-SECURE** for four seconds.

Clean the control panel with the soft side of a sponge dampened with a mild solution of detergent and warm water. Dry the control panel completely with a soft, lint-free cloth.

Cleaning Stainless Steel Surfaces

CAUTION

Always wipe stainless steel (silver colored) surfaces with the grain. To prevent scratching, do not use abrasive cleaners or scrubbers on stainless steel surfaces.

Clean stainless steel surfaces with a mild solution of detergent and warm water. Rinse and dry with a soft, lint-free cloth. You may also use Dacor Stainless Steel Cleaner. Use it according to the directions on the package.

Cleaning Brass, Chrome and Copper Surfaces

CAUTION

To prevent scratching, do not use abrasive cleaners or scrubbers on metal surfaces.

Using a soft cloth, clean metal surfaces with a mild solution of detergent and warm water. Rinse and dry with a soft, lint-free cloth.

Glass Cleaning (Interior and Exterior)

Use a mild glass cleaner to remove finger prints on glass surfaces. You can also clean glass surfaces with Dacor Cooktop Cleaning Creme. Use it according to the directions on the package.

You may scrub the oven light lens with the rough side of a sponge and warm, soapy water. Be careful not to scratch it.

Cleaning the Oven

WARNING

To avoid electrical shock or burns, turn off the oven and be sure that it is cool before cleaning.

Your oven's self clean feature eliminates the need for manual scrubbing of interior surfaces. The steps below are for cleaning surfaces and items that are not cleaned by the self clean process. To use the self clean feature see page 24.

Cleaning the Convection Filter

WARNING

For your safety and proper oven performance, re-install the filter before using the oven to cook. If you don't, the spinning fan blades at the back of the oven will be exposed.

The convection filter is located in the back of each oven chamber. Clean the filter regularly. If you allow it to become clogged, the oven's convection cooking modes will not work properly. You also need to remove the filter during the self clean cycle.

Removing your oven's convection filter:

When the oven is cool, put your fingers around the edges of the filter and gently push up.

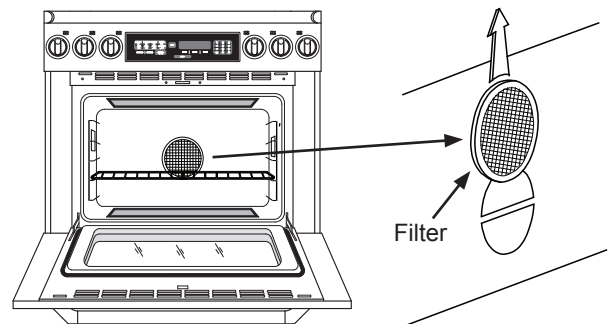

To clean the filter:

Soak it in hot, soapy water. Rinse well. You may also place it in a dishwasher on the top rack. Dry the filter before re-installing it.

Installing your oven's convection filter:

Carefully hook the metal clips on the back of the filter over the metal bar across the fan hole. Make sure it is centered over the hole. Be careful not to scratch the porcelain surfaces with the back of the filter.

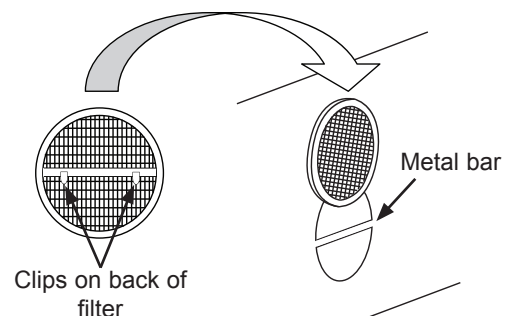

Care and Cleaning

General Cleaning (continued)

Cleaning the Door Gasket (Seal)

WARNING

Take extreme caution when cleaning the door gasket. Rubbing or displacing it may damage the tight door seal required for proper cooking and self cleaning.

Clean the door gasket by dabbing it with a solution of water and mild soap. Do not scrub it or it will become damaged.

Cleaning the Oven Racks

CAUTION

To prevent damage, do not self clean the oven racks.

To clean the oven racks, apply a solution of detergent and hot water. When you need to clean heavy soil, use a scouring pad such as steel wool with plenty of water. You may also use a solution of one cup of ammonia to two gallons of water.

Cleaning the Meat Probe

WARNING

To prevent damage, do not immerse the meat probe in water.

The meat probe is constructed of silicone handles, a wire, a plug and a stainless steel skewer. To clean the skewer, use a scouring pad and hot, soapy water. When you clean the handles, wipe them with a soft sponge soaked with a solution of detergent and warm water.

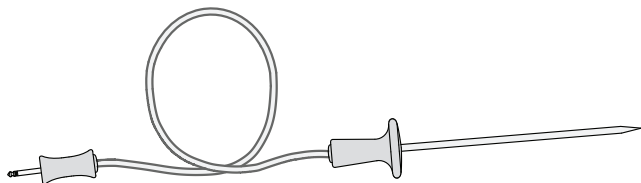

Cleaning the Broil Pan

Your broil pan has a porcelain enamel finish. When you clean it, use a solution of detergent and hot water. If your broil pan is heavily soiled, use a scouring pad with plenty of water. Rinse it well after cleaning.

Cleaning the Griddle

Clean the griddle after each use. Wash it thoroughly in hot soapy water to avoid stains from grease build-up. The griddle is coated with a non-stick coating for easy cleaning. Warm water and liquid detergent are all that are needed for cleaning. Remove stubborn spots with a non-abrasive plastic mesh pad. To prevent scratching, do not use abrasives or abrasive cleaners. Use the soft side of a sponge to scrub it. Dry it with a lint-free cloth.

Cleaning the Optional Roast/Broil Pan with "V" Shaped Rack

Your roast/broil pan has a porcelain enamel finish. When you clean it, use a solution of detergent and hot water. If your roast/broil pan is heavily soiled, use a scouring pad and plenty of water.

Rinse it well after cleaning.

The optional "V" shaped rack is finished with an Excalibur™ nonstick coating. When you clean it, use a mild solution of detergent and warm water. Use the soft side of a sponge to scrub it and dry it with a lint-free cloth.

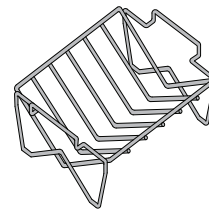

Cleaning the Optional Baking Stone

Wash the optional baking stone with hot water and scrub it clean before you use it for the first time. Do not use any soap or detergents to wash the stone. The stone is porous and soap will get trapped inside. The trapped soap will affect the flavor of the food cooked on it. Don't be alarmed if the stone gets stains on it after it is used for a while. Stains do not affect the stone's ability to bake properly.

When you need to remove large food particles from the baking stone, use warm water and a scrub brush. If there is a lot of oil build-up, it may smoke and create odors. If you need to remove the oily build up, use a scouring pad or brush to remove it. You may also use a paste of baking soda and water to scrub off small stains.

Cleaning the Optional Cookie Sheets

Clean the optional aluminum cookie sheets with a solution of detergent and warm water. Since aluminum can scratch, you need to use the soft side of a sponge. A way for you to keep cookie sheets cleaner is to use parchment paper over the cooking surface during baking. The parchment paper will also prevent food from sticking.

Care and Cleaning

Replacing the Light Bulbs

WARNING

- To prevent electrical shock and/or personal injury, make certain that the oven and light bulb(s) are cool and that power to the oven has been turned off at the main power supply before replacing the light bulb(s).
- Always make sure the lens covers are in place when using the oven. The lens covers protect the bulbs from breakage.
- Replacing the lens cover without lining up the cutout with the light socket will damage the light fixture.
- Do not use a screwdriver to remove the lens cover.

Light bulb replacement is considered to be a homeowner maintenance operation. If the lights do not work, before replacing them, please consult the **Problem Solution Guide** on page 30.

IMPORTANT: Do not touch the replacement halogen light bulb with your fingers. Halogen bulbs are sensitive to the oils from your hand. The oils from your hand will stick to the bulb and may cause it to burn out faster than normal.

To replace the light bulbs, follow these steps:

1. Replace the light bulb only with Dacor part number 100429. See page 32 for ordering information.
2. Turn off power to the range at the circuit breaker panel or fuse box.
3. Hold your hand under the lens for support and gently pry it loose using a spatula or table knife. Pull the lens cover straight out.
4. Grasp the old bulb and pull it straight out of the socket.
5. Using a glove, insert the new bulb into the socket.
6. As you reinstall the lens cover, line up the cutout on the inside rim with the light socket. Gently press it into its original position.
7. Turn the power to the range back on. Reset the clock (see page 10).

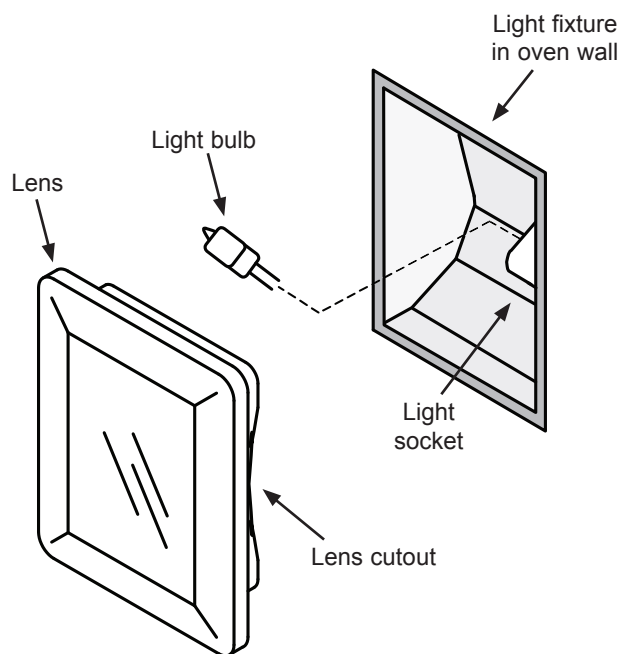

Adjusting the Oven Temperature Control



Even though your oven is adjusted at the factory to cook at the temperature shown on the display, it may cook faster or slower than your old oven.

WARNING

Do not adjust the probe or self clean offset temperatures. The offset for the probe and self clean offsets must remain at 0 for proper and/or safe operation.

IMPORTANT: Do not measure the temperature inside the oven with a thermometer. Opening the door will cause an incorrect reading. Also, the temperature inside the oven will vary as the elements cycle on and off.

If you are not satisfied with the results from your oven, you can adjust the temperature offset as follows:

1. With the oven off, press and hold the **BAKE** key for about six seconds. On model ER48D, press the **BAKE** key for the oven you wish to adjust. 
2. The current offset temperature will appear on the display, for example "0," if you have not adjusted the temperature before.
3. Enter the new offset temperature.
4. Within six seconds, enter the amount you want to increase or decrease the temperature on the number keypad. To enter a minus sign, press the **SELF CLEAN** key after the number(s). A minus sign means that the oven will be cooler by the amount shown. When there is no sign in front of the number, the oven will be hotter by the amount shown. You may enter a number between 35°F or -35°F (19°C or -19°C). 
5. Press **CANCEL/SECURE** to save the changes. 

IMPORTANT: If you do not press **CANCEL/SECURE**, your changes will not be saved.

Determining the Amount of Adjustment Needed

See the chart below for suggestions on the amount you need to adjust the oven for the results you want. The amount of food browning, moistness and rise time during baking will suggest the amount of adjustment you need.

To Cook Food...	Change Temperature By...
A little bit more...	+10°F (+6°C)
Moderately more...	+20°F (+11°C)
A lot more...	+30°F (+17°C)
A little bit less...	-10°F (-6°C)
Moderately less...	-20°F (-11°C)
A lot less...	-30°F (-17°C)

Before You Call for Service

Problem Solution Guide - Oven

NOTE: See *Common Problems When Using the Bake Mode* in the *Operating the Oven* section for problems with cooking food.

Problem	May Be Caused By	What to Do
Nothing works.	Range not connected to electrical power.	Have electrician connect range to properly wired electrical connection.
	Power is off.	Turn power on at junction box. Check for tripped circuit breaker or blown fuse.
	Control panel locked.	Press CANCEL-SECURE key for four seconds to reactivate control panel.
	Power outage.	Contact power company.
Oven will not heat.	Oven setting not correct.	Press CANCEL-SECURE , then follow instructions in <i>Operating the Oven</i> section of this manual.
	Oven set for delay timed cooking.	Oven will turn on automatically at preset time. Press CANCEL-SECURE to return to normal operation.
	Attempting to broil with meat probe connected.	Broil and convection broil settings will not work when meat probe is connected. Disconnect meat probe.
Oven shuts off by itself after it has been on for 12 hours.	12 hour shut-off feature is on. Unit is set to turn off automatically after 12 hours of continuous use.	Turn off 12 hour shut-off. See page 15.
Time on display not correct.	Time of day not set.	Set time. See <i>Setting Up Your Range</i> section.
	Power failure or power was turned off.	Reset time. See <i>Setting Up Your Range</i> section.
Time flashes on display.	Power failure or power was turned off.	Reset time. See <i>Setting Up Your Range</i> section.
Oven does not self clean.	Door not shut tightly.	Check for obstructions. Close door tightly.
	Oven set for delay timed cleaning.	Oven will start to self clean at preset time. Press CANCEL-SECURE to return to normal operation.
	Model ER48D only: Other oven is on or self-cleaning	Due to power consumption on model ER48D, one oven cannot self clean while the other is in use or self cleaning. Turn off other oven.
	Oven not set properly.	Follow instructions in <i>Care and Cleaning</i> section of this manual.
	Meat probe connected.	Oven will not start self clean cycle when meat probe is connected. Disconnect and remove meat probe.
Oven lights will not work.	Oven in self clean mode.	Lights do not work when oven is in self clean mode.
	Light bulbs burned out.	Replace light bulbs. See <i>Care and Cleaning</i> section.
Foods over or under cook.	Incorrect cooking time or temperature.	Follow instructions in <i>Operating the Oven</i> section.
Cooling fan continues to run after oven is turned off.	Normal operation.	The cooling fan may run for a while after the oven is turned off, until the internal parts have cooled.
Oven door will not open.	Oven is set to self clean.	Check display. If " LOCK " appears on display oven door cannot be opened. Wait for oven to complete self clean cycle or press CANCEL-SECURE . Door will unlock once oven has cooled.

Before You Call for Service

Problem Solution Guide - Cooktop

Problem	May Be Caused By	What to Do
Igniters do not spark.	Power not supplied to unit.	Have electrician connect range to properly wired electrical connection.
	Power to range is off.	Turn power on at junction box. Check for tripped circuit breaker or blown fuse.
	Wet or dirty igniter.	Clean according to Care and Cleaning section.
	Power outage.	Contact power company.
No flame.	Igniter not working (no clicking sound).	Clean according to Care and Cleaning section.
	Wet or dirty igniter.	Clean and dry according to Care and Cleaning section.
	Gas is turned off.	Make sure the gas supply valve is in the on position.
	Gas supply interrupted.	Contact gas company.
Flame is distorted, yellow or very large.	Burner ring or burner cap is dirty or clogged.	Clean and dry according to Care and Cleaning section.
	Burner ring or burner cap not properly positioned.	Make sure burner is assembled according to the Setting Up Your Range section.
	Range set up to use a different type of gas (Natural or LP) or set up for different altitude.	Have qualified service technician check to make sure that the range is set up for the type of gas and the correct altitude.
	Gas regulator is not installed or faulty.	Have qualified service technician check the gas regulator.
Igniter continues to spark (click) after flame ignites.	Burner is cold.	Burners may continue to spark for up to 60 seconds when cold and set to low. See Operating the Cooktop section for more information on how to minimize.
	Flame distorted by air draft.	Minimize any air drafts around the range. Close nearby windows.
	Wet or dirty igniter.	Clean and dry according to Care and Cleaning section.
	Burner ring or burner cap is dirty.	Clean and dry according to Care and Cleaning section.
	Burner ring or burner cap not properly positioned.	Make sure burner is assembled according to the Setting Up Your Range section.
Flame goes out at low setting.	Air intake holes obstructed.	Check to make sure air holes above knobs are not blocked.
	Low gas pressure.	Contact gas company.

Replacement Parts and Accessories

Description	Dacor Part Number
Halogen light bulb (12 Volt, 20 Watt)	100429
Meat probe	72723
Wok ring	AWR4
Cooktop griddle	AG1424
Cooktop grill	AEGR3648
Standard broil pan	82107
Standard broil pan grill	82108
3-Inch backguard, model ER36D	AERB36D03
3-Inch backguard, model ER48D	AERB48D03
9-Inch backguard, model ER36D	AERB36D09
9-Inch backguard, model ER48D	AERB48D09
24-Inch backguard, model ER36D	AERB36D24
24-Inch backguard, model ER48D	AERB48D24
Standard type oven rack, model ER36D and large oven on model ER48D	62783
Standard type oven rack, small oven on model ER48D	62782
GlideRack™ oven rack	ARGRK36
Large capacity roast/broil pan with "V" shaped rack	AORPVR
Pizza baking stone	ABS16
Cookie sheets* , models ER36D and ER48D (3 per carton)	ACS363
10" grate, model ER36D (2 used per unit)	700037
14" grate, model ER36D (1 used per unit) and ER48D (3 used per unit)	700038
Toe skirt kit, model ER36D	ARTS36
Toe skirt kit, model ER48D	ARTS48
Black Knob Kit	AKBID6

* The Dacor full sized cookie sheets maximize oven rack baking capabilities by utilizing the total usable rack space.

To order parts and accessories, contact your Dacor dealer or visit www.everythingdacor.com.

Warranty and Service

Getting Help

Before you request service:

1. Review **Before You Call for Service** section of this manual (see page 30).
2. Use the helpful tips found in our **Problem Solution Guide**.
3. Become familiar with the warranty terms and conditions of your product.
4. If none of these tips or suggestions resolves your problem, call our Customer Service center at the number below.

Dacor's Customer Service center is available 6:00 A.M. – 5:00 P.M. Pacific Time

For warranty repairs or questions and for Dacor Distinctive Service (DDS) in the US and Canada
Phone: (800) 793-0093, extension 2822

For non-warranty repairs or questions in the US and Canada
Phone: (800) 793-0093, extension 2813

Contact us through our web site at:

www.dacor.com/contact-us

Warranty and Service

Warranty

What Is Covered

CERTIFICATE OF WARRANTIES: DACOR RANGES

WITHIN THE FIFTY STATES OF THE U.S.A., THE DISTRICT OF COLUMBIA AND CANADA*:

FULL ONE-YEAR WARRANTY

The warranty applies only to the Dacor appliance sold to the first use purchaser, starting from the date of original retail purchase or closing date for new construction, whichever period is longer. Warranty is valid on products purchased brand new from a Dacor Authorized Dealer, or other seller authorized by Dacor.

If your Dacor product fails to function within one year of the original date of purchase, due to a defect in material or workmanship, Dacor will remedy it without charge to you.

All cosmetic damage (such as scratches on stainless steel, paint/porcelain blemishes, etc.) to the product or included accessories must be reported to Dacor within 60 days of the original purchase date to qualify for warranty coverage.

Consumable parts such as filters and light bulbs are not covered and are the responsibility of the purchaser.

LIMITATIONS OF COVERAGE

Service will be provided by a Dacor designated service company during regular business hours. Please note service providers are independent entities and are not agents of Dacor.

Dealer display and model home display products with a production date greater than 5 years, products sold "As Is," and products installed for non-residential use, which include but not limited to religious organizations, fire stations, bed & breakfast, and spas carry a one year parts warranty only. All delivery, installation, labor costs, and other service fees are the responsibility of the purchaser.

Warranty will be null and void on product that has altered, defaced, or missing serial numbers and tags.

The owner must provide proof of purchase or closing statement for new construction upon request. All Dacor products must be accessible for service.

*Warranty is null and void if non-ETL or non-CUL approved product is transported from the U.S.A.

OUTSIDE THE FIFTY STATES OF THE U.S.A., THE DISTRICT OF COLUMBIA AND CANADA:

LIMITED FIRST YEAR WARRANTY

If your Dacor product fails to function within one year of the original date of purchase due to a defect in material or workmanship, Dacor will furnish a new part, F.O.B. factory to replace the defective part.

All delivery, installation, labor costs, and other service fees are the responsibility of the purchaser.

What Is Not Covered

- Slight color variations may be noticed because of differences in painted parts, kitchen lighting, product placement, and other factors; this warranty does not apply to color variation.
- Service calls to educate the customer on proper use and care of the product.
- Service fees for travel to islands and remote areas, which include but not limited to, ferries, toll roads or other travel expenses.
- Consequential or incidental damage, including but not limited to food or medicine loss, time away from work or restaurant meals.
- Failure of the product when used for commercial, business, rental or any application other than for residential consumer use.
- Failure of the product caused by improper product installation.
- Replacement of house fuses, fuse boxes or resetting of circuit breakers.
- Damage to the product caused by accident, fire, flood, power interruption, power surges or other acts of God.
- Liability or responsibility for damage to surrounding property including cabinetry, floors, ceilings and other structures or objects around the product.
- Breakage, discoloration, or damage to glass, metal surfaces, plastic components, trim, paint or other cosmetic finish caused by improper usage, care, abuse, or neglect.

Out of Warranty

Should you experience a service issue beyond the standard warranty period, please contact us. Dacor reviews each issue and customer concern to provide the best possible solution based on the circumstances.

THE REMEDIES PROVIDED IN THE ABOVE EXPRESS WARRANTIES ARE THE SOLE AND EXCLUSIVE REMEDIES. THEREFORE, NO OTHER EXPRESS WARRANTIES ARE MADE, AND OUTSIDE THE FIFTY STATES OF THE UNITED STATES, THE DISTRICT OF COLUMBIA AND CANADA, ALL IMPLIED WARRANTIES, INCLUDING BUT NOT LIMITED TO, ANY IMPLIED WARRANTY OF MERCHANTABILITY OR FITNESS FOR A PARTICULAR USE OR PURPOSE, ARE LIMITED IN DURATION TO ONE YEAR FROM THE DATE OF ORIGINAL PURCHASE. IN NO EVENT SHALL DACOR BE LIABLE FOR INCIDENTAL EXPENSE OR CONSEQUENTIAL DAMAGES. IN THE EVENT DACOR PREVAILS IN ANY LAWSUIT, DACOR SHALL BE ENTITLED TO REIMBURSEMENT OF ALL COSTS AND EXPENSES, INCLUDING ATTORNEY'S FEES, FROM THE DACOR CUSTOMER. NO WARRANTIES, EXPRESS OR IMPLIED, ARE MADE TO ANY BUYER FOR RESALE.

Some states do not allow limitations on how long an implied warranty lasts, or do not allow the exclusion or limitation of consequential damages, therefore the above limitations or exclusions may not apply to you. This warranty gives you specific legal rights, and you may also have other rights that vary from state to state.

Notes

Notes

Notes

fold here



NO POSTAGE
NECESSARY
IF MAILED
IN THE
UNITED STATES

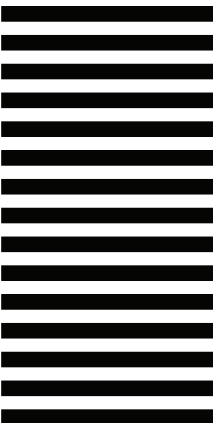

BUSINESS REPLY MAIL
FIRST-CLASS MAIL PERMIT NO 1600 CITY OF INDUSTRY CA

POSTAGE WILL BE PAID BY ADDRESSEE

**DACOR
ATTN WARRANTY PROCESSING DEPT
PO BOX 90070
CITY OF INDUSTRY CA 91715-9907**





Please visit www.dacor.com to activate your warranty online.

WARRANTY INFORMATION



IMPORTANT:

Your warranty will not be activated until you activate it online or return this form to Dacor. If you have purchased more than one Dacor product, please return all forms in one envelope or activate the warranty for each product online.

Please rest assured that under no conditions will Dacor sell your name or any of the information on this form for mailing list purposes. We are very grateful that you have chosen Dacor products for your home and do not consider the sale of such information to be a proper way of expressing our gratitude!

Owner's Name: _____
Last (Please Print or Type) First Middle

Street: _____

City: _____ State: _____ Zip: _____

Purchase Date: _____ Email: _____ Telephone: _____

Dealer: _____

City: _____ State: _____ Zip: _____

Your willingness to take a few seconds to fill in the section below will be sincerely appreciated. Thank you.

1. How were you **first** exposed to Dacor products? (Please check one only.)

- A. T.V. Cooking Show
- B. Magazine
- C. Appliance Dealer Showroom
- D. Kitchen Dealer Showroom
- E. Home Show
- F. Builder
- G. Architect/Designer
- H. Another Dacor Owner
- I. Model Home
- J. Other _____

2. Where did you buy your Dacor appliances?

- A. Appliance Dealer
- B. Kitchen Dealer
- C. Builder Supplier
- D. Builder
- E. Other _____

3. For what purpose was the product purchased?

- A. Replacement **only**
- B. Part of a Remodel
- C. New Home
- D. Other _____

4. What is your household income?

- A. Under \$75,000
- B. \$75,000 – \$100,000
- C. \$100,000 – \$150,000
- D. \$150,000 – \$200,000
- E. \$200,000 – \$250,000
- F. Over \$250,000

5. What other brands of appliances do you have in your kitchen?

- A. Cooktop _____
- B. Oven _____
- C. Dishwasher _____
- D. Refrigerator _____

6. Would you buy or recommend another Dacor product?

- Yes
- No

Comments: _____

Thank you very much for your assistance. The information you have provided will be extremely valuable in helping us plan for the future and giving you the support you deserve.



cut here