



Model IW5739-00
20V Brushless Impact Wrench



Model BY519603
**20V Lithium Battery
with Fuel Gauge**



Model AD592301
**20V PWRAssist
USB Charging Adapter**

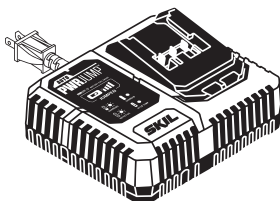

Model QC536001
20V Charger

SKIL®

Owner's Manual



Model: IW5739-00

PWRCORE 20™ **20V Brushless Impact Wrench**

▲ WARNING: To reduce the risk of injury, the user must read and understand the Owner's Manual before using this product. Save these instructions for future reference.



*For Customer Service
Pour le service à la clientèle
Servicio al cliente*

1-877-SKIL-999 OR **www.skil.com**

TABLE OF CONTENTS

General Power Tool Safety Warnings	3-5
Safety Warnings for Impact Wrench	5
Symbols	6-9
Get to Know Your Impact Wrench	10
Specifications	10
Operating Instructions	11-15
Maintenance	16
Trouble Shooting	16
Limited Warranty of Skil Cordless Tool	17

WARNING

- Some dust created by power sanding, sawing, grinding, drilling and other construction activities contains chemicals known to the State of California to cause cancer, birth defects or other reproductive harm. Some examples of these chemicals are:
 - Lead from lead-based paints.
 - Crystalline silica from bricks, cement, and other masonry products.
 - Arsenic and chromium from chemically-treated lumber.
- Your risk from these exposures varies, depending upon how often you do this type of work. To reduce your exposure to these chemicals:
 - Work in a well-ventilated area.
 - Work with approved safety equipment, such as dust masks that are specially designed to filter out microscopic particles.
 - Avoid prolonged contact with dust from power sanding, sawing, grinding, drilling, and other construction activities. Wear protective clothing and wash exposed areas with soap and water. Allowing dust to get into your mouth or eyes or to lie on the skin may promote absorption of harmful chemicals.

General Power Tool Safety Warnings



Read all safety warnings, instructions, illustrations and specifications provided with this power tool. Failure to follow all instructions listed below may result in electric shock, fire and/or serious injury.

SAVE ALL WARNINGS AND INSTRUCTIONS FOR FUTURE REFERENCE.

The term “power tool” in the warnings refers to your mains-operated (corded) power tool or battery-operated (cordless) power tool.

Work area safety

Keep work area clean and well lit. Cluttered or dark areas invite accidents.

Do not operate power tools in explosive atmospheres, such as in the presence of flammable liquids, gases or dust. Power tools create sparks which may ignite the dust or fumes.

Keep children and bystanders away while operating a power tool. Distractions can cause you to lose control.

Electrical safety

Power tool plugs must match the outlet. Never modify the plug in any way. Do not use any adapter plugs with earthed (grounded) power tools. Unmodified plugs and matching outlets will reduce risk of electric shock.

Avoid body contact with earthed or grounded surfaces, such as pipes, radiators, ranges and refrigerators. There is an increased risk of electric shock if your body is earthed or grounded.

Do not expose power tools to rain or wet conditions. Water entering a power tool will increase the risk of electric shock.

Do not abuse the cord. Never use the cord for carrying, pulling or unplugging the power tool. Keep cord away from heat, oil, sharp edges or moving parts. Damaged or entangled cords increase the risk of electric shock.

When operating a power tool outdoors, use an extension cord suitable for outdoor use. Use of a cord suitable for outdoor use reduces the risk of electric shock.

If operating a power tool in a damp location is unavoidable, use a ground fault circuit interrupter (GFCI) protected supply. Use of a GFCI reduces the risk of electric shock.

Personal safety

Stay alert, watch what you are doing and use common sense when operating a power tool. Do not use a power tool while you are tired or under the influence of drugs, alcohol or medication. A moment of inattention while operating power tools may result in serious personal injury.

Use personal protective equipment. Always wear eye protection. Protective equipment such as a dust mask, non-skid safety shoes, hard hat or hearing protection used for appropriate conditions will reduce personal injuries.

Prevent unintentional starting. Ensure the switch is in the off-position before connecting to power source and/or battery pack, picking up or carrying the tool. Carrying power tools with your finger on the switch or energising power tools that have the switch on invites accidents.

Remove any adjusting key or wrench before turning the power tool on. A wrench or a key left attached to a rotating part of the power tool may result in personal injury.

Do not overreach. Keep proper footing and balance at all times. This enables better control of the power tool in unexpected situations.

Dress properly. Do not wear loose clothing or jewellery. Keep your hair and clothing away from moving parts. Loose clothes, jewellery or long hair can be caught in moving parts.

If devices are provided for the connection of dust extraction and collection facilities, ensure these are connected and properly used. Use of dust collection can reduce dust-related hazards.

Do not let familiarity gained from frequent use of tools allow you to become complacent and ignore tool safety principles. A careless action can cause severe injury within a fraction of a second.

Power tool use and care

Do not force the power tool. Use the correct power tool for your application. The correct power tool will do the job better and safer at the rate for which it was designed.

Do not use the power tool if the switch does not turn it on and off. Any power tool that cannot be controlled with the switch is dangerous and must be repaired.

Disconnect the plug from the power source and/or remove the battery pack, if detachable, from the power tool before making any adjustments, changing accessories, or storing power tools. Such preventive safety measures reduce the risk of starting the power tool accidentally.

Store idle power tools out of the reach of children and do not allow persons unfamiliar with the power tool or these instructions to operate the power tool. Power tools are dangerous in the hands of untrained users.

Maintain power tools and accessories. Check for misalignment or binding of moving parts, breakage of parts and any other condition that may affect the power tool's operation. If damaged, have the power tool repaired before use. Many accidents are caused by poorly maintained power tools.

Keep cutting tools sharp and clean. Properly maintained cutting tools with sharp cutting edges are less likely to bind and are easier to control.

Use the power tool, accessories and tool bits etc. in accordance with these instructions, taking into account the working conditions and the work to be performed. Use of the power tool for operations different from those intended could result in a hazardous situation.

Keep handles and grasping surfaces dry, clean and free from oil and grease. Slippery handles and grasping surfaces do not allow for safe handling and control of the tool in unexpected situations.

Battery tool use and care

Recharge only with the charger specified by the manufacturer. A charger that is suitable for one type of battery pack may create a risk of fire when used with another battery pack.

Use power tools only with specifically designated battery packs. Use of any other battery packs may create a risk of injury and fire.

When battery pack is not in use, keep it away from other metal objects, like paper clips, coins, keys, nails, screws or other small metal objects, that can make a connection from one terminal to another. Shorting the battery terminals together may cause burns or a fire.

Under abusive conditions, liquid may be ejected from the battery; avoid contact. If contact accidentally occurs, flush with water. If liquid contacts eyes, additionally seek medical help. Liquid ejected from the battery may cause irritation or burns.

Do not use a battery pack or tool that is damaged or modified. Damaged or modified

batteries may exhibit unpredictable behaviour resulting in fire, explosion or risk of injury.

Do not expose a battery pack or tool to fire or excessive temperature. *Exposure to fire or temperature above 265 °F may cause explosion.*

Follow all charging instructions and do not charge the battery pack or tool outside the temperature range specified in the instructions. *Charging improperly or at temperatures outside the specified range may damage the battery and increase the risk of fire.*

Service

Have your power tool serviced by a qualified repair person using only identical replacement parts. *This will ensure that the safety of the power tool is maintained.*

Never service damaged battery packs. Service of battery packs should only be performed by the manufacturer or authorized service providers.

SAFETY WARNINGS FOR IMPACT WRENCH





Hold the power tool by insulated gripping surfaces, when performing an operation where the fastener may contact hidden wiring. Fasteners contacting a “live” wire may make exposed metal parts of the power tool “live” and could give the operator an electric shock.

SYMBOLS

Safety Symbols

The purpose of safety symbols is to attract your attention to possible dangers. The safety symbols and the explanations with them deserve your careful attention and understanding. The symbol warnings do not, by themselves, eliminate any danger. The instructions and warnings they give are no substitutes for proper accident prevention measures.

⚠ WARNING Be sure to read and understand all safety instructions in this Owner's Manual, including all safety alert symbols such as "**DANGER**," "**WARNING**," and "**CAUTION**" before using this tool. Failure to following all instructions listed below may result in electric shock, fire, and/or serious personal injury.

The definitions below describe the level of severity for each signal word. Please read the manual and pay attention to these symbols.	
	This is the safety alert symbol. It is used to alert you to potential personal injury hazards. Obey all safety messages that follow this symbol to avoid possible injury or death.
	DANGER indicates a hazardous situation which, if not avoided, will result in death or serious injury.
	WARNING indicates a hazardous situation which, if not avoided, could result in death or serious injury.
	CAUTION, used with the safety alert symbol, indicates a hazardous situation which, if not avoided, will result in minor or moderate injury.

Damage Prevention and Information Messages

These inform the user of important information and/or instructions that could lead to equipment or other property damage if they are not followed. Each message is preceded by the word "NOTICE", as in the example below:









NOTICE: Equipment and/or property damage may result if these instructions are not followed.





⚠ WARNING The operation of any power tools can result in foreign objects being thrown into your eyes, which can result in severe eye damage. Before beginning power tool operation, always wear safety goggles or safety glasses with side shields and a full face shield when needed. We recommend a Wide Vision Safety Mask for use over eyeglasses or standard safety glasses with side shields. Always use eye protection which is marked to comply with ANSI Z87.1.

SYMBOLS (CONTINUED)







IMPORTANT: Some of the following symbols may be used on your tool. Please study them and learn their meaning. Proper interpretation of these symbols will allow you to operate the tool better and more safely.

Symbol	Name	Designation/Explanation
V	Volts	Voltage (potential)
A	Amperes	Current
Hz	Hertz	Frequency (cycles per second)
W	Watt	Power
kg	Kilograms	Weight
min	Minutes	Time
s	Seconds	Time
Wh	Watt-hours	Battery capacity
Ah	Ampere-Hours	Battery capacity
∅	Diameter	Size of drill bits, grinding wheels, etc.
n_0	No-load speed	Rotational speed, at no load
n	Rated speed	Maximum attainable speed
.../min	Revolutions or reciprocations per minute	Revolutions, strokes, surface speed, orbits, etc. per minute
0	Off position	Zero speed, zero torque...
1,2,3,... I,II,III,	Selector settings	Speed, torque or position settings. Higher number means greater speed
	Infinitely variable selector with off	Speed is increasing from 0 setting
	Arrow	Action in the direction of arrow
	Alternating current	Type or a characteristic of current
	Direct current	Type or a characteristic of current
	Alternating or direct current	Type or a characteristic of current
	Class II tool	Designates Double Insulated Construction tools.
	Earthing terminal	Grounding terminal
	Li-ion RBRC seal	Designates Li-ion battery recycling program

Symbol	Name	Designation/Explanation
	Ni-Cad RBRC seal	Designates Ni-Cad battery recycling program
	Read manual symbol	Alerts user to read manual
	Wear eye protection symbol	Always wear safety goggles or safety glasses with side shields and a full face shield when operating this product.

SYMBOLS (CERTIFICATION INFORMATION)

IMPORTANT: Some of the following symbols for certification information may be used on your tool. Please study them and learn their meaning. Proper interpretation of these symbols will allow you to operate the tool better and more safely.

Symbol	Designation/Explanation
	This symbol designates that this tool is listed by Underwriters Laboratories.
	This symbol designates that this tool is recognized by Underwriters Laboratories.
	This symbol designates that this tool is listed by Underwriters Laboratories, to United States and Canadian Standards.
	This symbol designates that this tool is listed by the Canadian Standards Association.
	This symbol designates that this tool is listed by the Canadian Standards Association, to United States and Canadian Standards.
	This symbol designates that this tool is listed by the Intertek Testing Services, to United States and Canadian Standards.
	This symbol designates that this tool complies to NOM Mexican Standards.

GET TO KNOW YOUR IMPACT WRENCH

20V Brushless Impact Wrench

Fig. 1

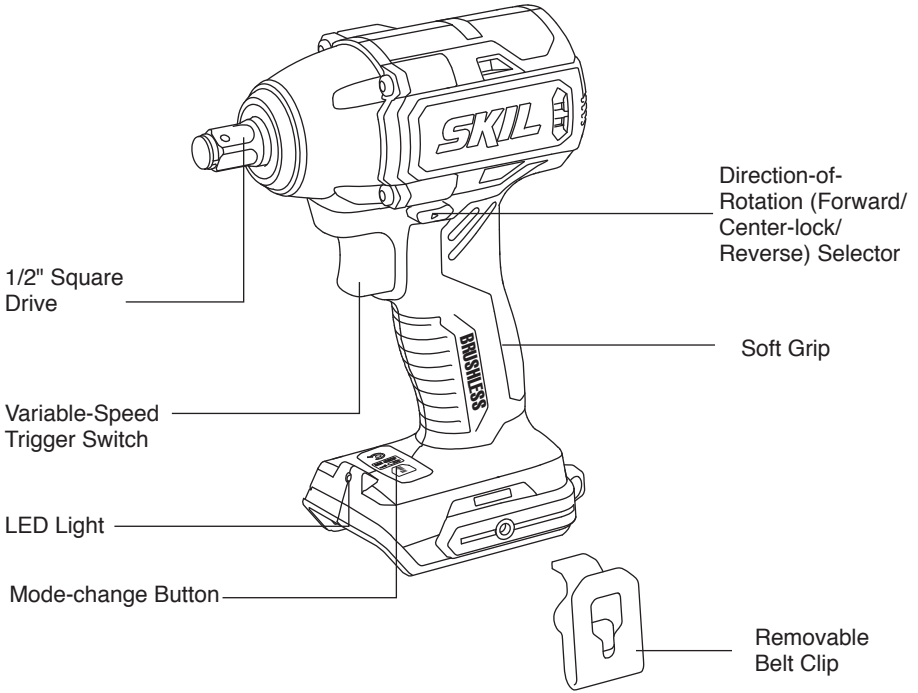

SPECIFICATIONS

Rated voltage	20V d.c.
Square drive	1/2"
No-load speed	0~2100/0~2400/min
Impacts per minute	0~2800/0~3200 /min
Recommended working temperature	14~104°F (-10~40°C)
Recommended storage temperature	32~104°F (0~40°C)

OPERATING INSTRUCTIONS

⚠ WARNING To reduce the risk of fire, personal injury, and product damage due to a short circuit, never immerse your tool, battery pack or charger in fluid or allow a fluid to flow inside them. Corrosive or conductive fluids, such as seawater, certain industrial chemicals, and bleach or bleach-containing products, etc. can cause a short circuit.

⚠ WARNING If any parts are damaged or missing, do not operate this product until the parts are replaced. Use of this product with damaged or missing parts could result in serious personal injury.

⚠ WARNING Do not attempt to modify this Impact Wrench or create accessories not recommended for use with this Impact Wrench. Any such alteration or modification is misuse and could result in a hazardous condition leading to possible serious injury.

⚠ WARNING To prevent accidental starting that could cause serious personal injury, always remove the battery pack from the Impact Wrench when assembling parts, making adjustments, cleaning, or performing maintenance.

This cordless impact wrench must be used only with the battery packs and chargers listed below:

Battery pack					Charger	
2Ah	2Ah	2.5Ah	4Ah	5Ah		
SKIL BY519701	SKIL BY519702	SKIL BY519703	SKIL BY519601	SKIL BY519603	SKIL SC535801	SKIL QC536001

NOTICE: Please refer to the battery and charger manual for detailed operating information.

To Attach/Detach Battery Pack (Fig.2)

Lock the trigger switch "OFF" on the tool by placing the direction-of-rotation (forward/center-lock/reverse) selector in the center position before attaching or detaching the battery pack.

To attach the battery pack:

Align the raised rib on the battery pack with the grooves of the tool, and then slide the battery pack onto the tool.

NOTICE: Make sure that the latch on the battery pack snaps into place and that the battery pack is secured to the tool before beginning operation.

To detach the battery pack:

Depress the battery-release button located on the front of the battery pack to release the battery pack. Pull the battery pack out and remove it from the tool.

NOTICE: When placing the battery pack onto the tool, be sure that the raised rib on the battery pack aligns with the groove inside the tool and that the latches snap into place properly. Improper attachment of the battery pack can cause damage to internal components.

⚠ WARNING Battery tools are always in operating condition. Therefore, the direction-of-rotation (forward/center-lock/reverse) selector should always be locked in center position when not in use or carrying at your side.

Fig. 2

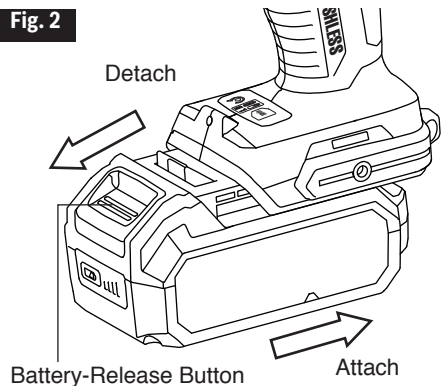

Direction-of-Rotation (Forward/Center-Lock/Reverse) Selector

⚠ WARNING After tool use, lock the direction-of-rotation selector in the “OFF” position (center-lock) to help prevent accidental starts and possible injury.

Your tool is equipped with a direction-of-rotation selector, located above the trigger switch. This selector is used to change the direction of rotation of the bit and to lock the variable-speed trigger in the “OFF” (center-lock) position (Fig. 3).

- Position the direction-of-rotation selector to the far right of the tool for forward rotation.
- Position the direction-of-rotation selector to the far left of the tool for reverse rotation.
- Setting the switch in “OFF” (center-lock) position helps to reduce the possibility of accidental starting when not in use.

NOTICE: To prevent gear damage, always allow the impact wrench to come to a complete stop before changing the direction of rotation.

NOTICE: The impact wrench will not run unless the direction-of-rotation selector is engaged fully to the left or right.

Fig. 3

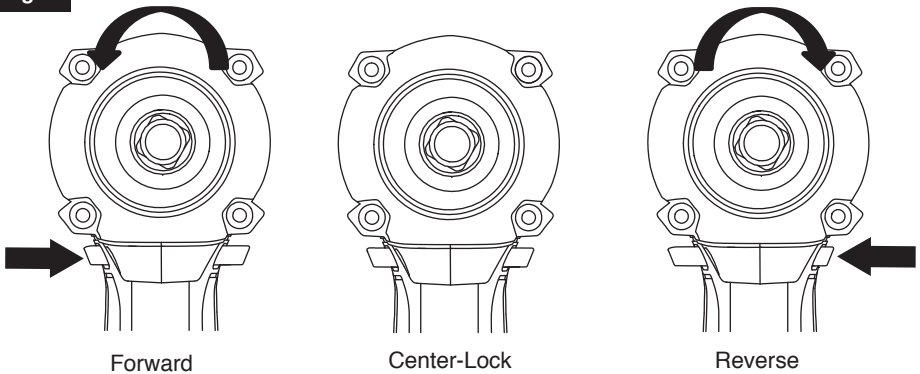

Variable-Speed Trigger Switch

Your tool is equipped with a variable-speed trigger switch. The tool can be turned “ON” or “OFF” by depressing or releasing the variable-speed trigger switch.

The variable-speed trigger switch delivers higher speed with increased trigger pressure and lower speed with decreased trigger pressure (Fig. 4).

Fig. 4

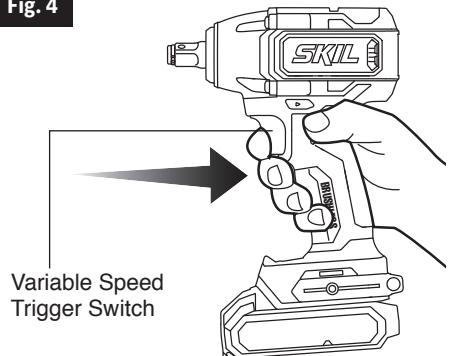

Changing the Impact Force (Fig.5)

Fig. 5

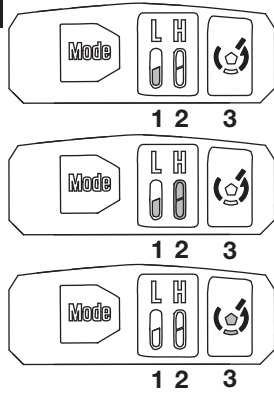

a. When the tool rotates clockwise (forward direction), you can change the impact force between two modes:

LO Mode

HI Mode.

This allows a tightening force suitable to the work. Every time the mode-change button is pressed, the number of mode progresses in order, as follows:

LO Mode

HI Mode

HI Mode.

- Indicator light 1 shines green for “LO Mode” to indicate “low-speed mode”.
- Both indicator light 1 and indicator light 2 shine green for “HI Mode” to indicate “high-speed mode”.
- Indicator light 3 shines green to indicate “high-speed mode”, which is same to the HI Mode.

b. When the tool rotates counterclockwise (reverse direction), you can change the impact force among three modes:

LO Mode

HI Mode

Reverse Control Mode.

Every time the mode-change button is pressed, the mode progresses in order, as follows:

LO Mode

HI Mode

Reverse Control Mode.

- Indicator light 1 shines green for “LO Mode” to indicate “low-speed mode”.
- Both indicator light 1 and indicator light 2 shine green for “HI Mode” to indicate “high-speed mode”.
- Indicator light 3 shines green to indicate “reverse control mode”.

In reverse control mode, the tool stops the reverse rotation and the impact within seconds once the fastener is loosened.

NOTICE: The reverse control mode is available only when the tool rotates counterclockwise and the trigger switch is fully depressed.

NOTICE: The impact force mode can be changed only when any mode-indicator light is shining and the trigger switch is not depressed. The impact force mode cannot be activated when the motor is running.

The impact force mode will be stored and applied in the next operation when the tool is turned on again or when the direction of rotation has been changed. Reset the impact modes as desired.

When the trigger is squeezed slightly, one of the three indicator lights will automatically shine green, to indicate the force mode stored at the last use and will turn off approximately 60 seconds after the variable speed trigger switch is released. It means that during approximately one minute after releasing the switch trigger, the impact force can be changed.

Impact force mode displayed	Maximum IPM (Impacts per minute)	Purpose	Example of application
High	3200 min ⁻¹ (/min)	Tightening when force and speed are desired.	Assembling steel frames
Low	2800 min ⁻¹ (/min)	Tightening when you need fine adjustment with small diameter bolt.	Assembling furnitures
Reverse Control Mode	3200 min ⁻¹ (/min)	Loosening with automatic control.	Disassembling nuts or bolts.

LED Light

Your tool is equipped with an LED light, located on the base of the tool. This provides additional light on the surface of the work piece for operation in lower-light areas.

The LED light will automatically turn on with a slight squeeze on the variable-speed trigger switch before the tool starts running, and will turn off approximately 10 seconds after the variable-speed trigger switch is released.

The LED light will rapidly flash when the tool and/or battery pack becomes overloaded or too hot, and the internal sensors will turn the tool off. Rest the tool for a while or place the tool and battery pack separately under air flow to cool them.

The LED light will flash more slowly to indicate that the battery is at low-battery capacity. Recharge the battery pack.

Fig. 6

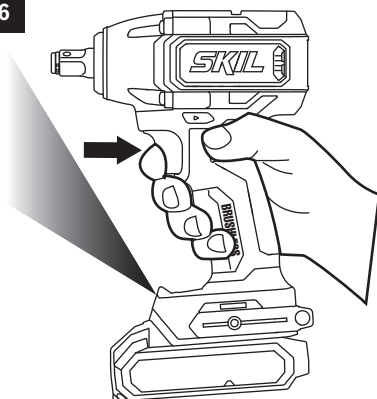

Removable Belt Clip (Fig.7)

Your tool is equipped with removable belt clip, which can be positioned on the left side of the tool for convenient transport.

Install the belt clip onto the tool:

- Remove the battery pack from the tool.
- Align the rib of the belt clip with the threaded hole on the base of the tool.
- Insert the screw and securely tighten the screw with a screwdriver.

Remove the belt clip from the tool:

- Remove the battery pack from the tool.
- Use a screwdriver to loosen the screw that attaches the belt clip to the impact wrench.
- Remove the screw and the belt clip.

Fig. 7

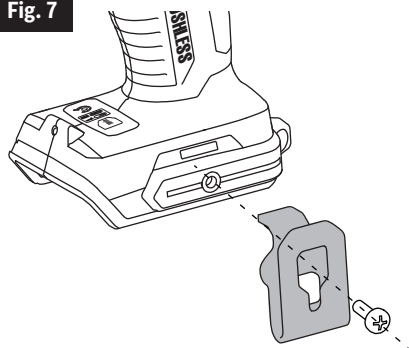

Install and Remove the Impact Socket (Fig.8)

Fig. 8

Lock the trigger switch "OFF" by placing the direction-of-rotation selector in the center position.

CAUTION: Make sure that the impact socket and the mounting portion are not damaged before installing the impact socket.

To install the Impact Socket:

- Align the square of the impact socket with the square drive and push the impact socket onto the square drive until it locks into place.
- Tap it lightly if required.

Remove the Impact Socket:

To remove the impact socket, simply pull it off.

⚠ WARNING Use protective gloves when removing the impact socket from the tool, or first allow the impact socket to cool down. The impact socket may be hot after prolonged use.

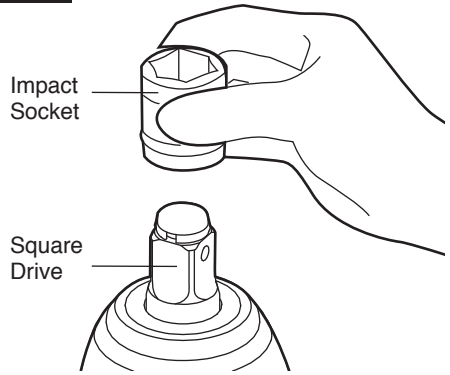

Tighten and loosen nuts and bolts

Variable speed control must be used with caution for driving nuts and bolts with socket set attachments. The technique is to start slowly, increasing speed as the nut or bolt runs down. Set the nut or bolt snugly by slowing the tool to a stop. If this procedure is not followed, the tool will have a tendency to torque or twist in your hands when the nut or bolt seats.

- Select hex socket that matches the nut or bolt. Then mount the socket on the square drive, and grip the nut or bolt to be tightened with the hex socket.
- Hold the tool firmly and apply just enough pressure to keep the socket engaged on the nut or bolt. Then press the trigger switch to impact the nut or bolt for several seconds.

NOTICE: Always use the correct size impact socket for bolts and nuts. An incorrect size impact socket will result in inaccurate and inconsistent fastening torque and/or damage to the bolt or nut.

⚠ WARNING Do not over-tighten, as the force of the impact tool can break the fastener. Hold the tool vertical with the bolt or nut, otherwise the head of the bolt or nut will be damaged.

MAINTENANCE

⚠ WARNING To avoid serious personal injury, always remove the battery pack from the tool when cleaning or performing any maintenance.

Service

⚠ WARNING Preventive maintenance performed by unauthorized personnel may result in misplacing of internal wires and components which could cause serious hazard. We recommend that all tool service be performed by a Skil Factory Service Center or Authorized Skil Service Station.

General Maintenance

⚠ WARNING When servicing, use only identical replacement parts. Use of any other parts could create a hazard or cause product damage.

NOTE: Periodically inspect the entire product for damaged, missing, or loose parts such as screws, nuts, bolts, caps, etc. Tighten securely all fasteners and caps and do not operate this product until all missing or damaged parts are replaced. Please contact customer service or an authorized service center for assistance.

Cleaning

⚠ WARNING The tool may be cleaned most effectively with compressed dry air. **Always wear safety goggles when cleaning tools with compressed air.**

Ventilation openings and switch levers must be kept clean and free of foreign matter. Do not attempt to clean by inserting pointed objects through openings.

⚠ WARNING Certain cleaning agents and solvents damage plastic parts. Some of these are: gasoline, carbon tetrachloride, chlorinated cleaning solvents, ammonia and house hold detergents that contain ammonia.

Storage

Store the tool indoors in a place that is inaccessible to children. Keep away from corrosive agents.

TROUBLE SHOOTING

Problem	Cause	Remedy
Tool will not start.	<ol style="list-style-type: none">1. Battery pack is depleted.2. Tool is over-loaded.3. Battery pack is over temperature.4. Battery pack is not installed properly.5. Burned out switch.	<ol style="list-style-type: none">1. Charge the battery.2. Release the variable-speed trigger switch and try again.3. Turn off the impact wrench and cool the battery pack under air flow.4. Confirm that the battery is locked and secured to the tool.5. Have the switch replaced by an Authorized SKIL Service Center or Service Station.
LED light rapidly flashes.	<ol style="list-style-type: none">1. Tool is over-loaded.2. Tool is over-temperature.	<ol style="list-style-type: none">1. Release the trigger switch.2. Cool the tool under air flow.

LIMITED WARRANTY FOR SKIL CORDLESS TOOL

5 YEARS LIMITED WARRANTY

Chervon North America, Inc. (“Seller”) warrants to the original purchaser only, that all SKIL consumer POWER TOOLS will be free from defects in material or workmanship for a period of five years from date of purchase, if original purchaser registers the product within 30 days from purchase. BATTERIES AND CHARGERS are warranted for 2 years. Product registration can be completed online at www.Registermyskil.com. Original purchasers should also retain their receipt as proof of purchase. THE FIVE-YEAR WARRANTY PERIOD FOR POWER TOOLS IS CONDITIONED ON REGISTRATION OF THE PRODUCT WITHIN 30 DAYS OF PURCHASE. If original purchasers do not register their product timely, the foregoing limited warranty will apply for a duration of three years for power tools. All batteries and chargers will remain under the two-year limited warranty.

Notwithstanding the foregoing, if a SKIL consumer portable power tool is used for industrial, professional or commercial purposes, the foregoing warranty will apply for a duration of ninety days, regardless of registration.

SELLER’S SOLE OBLIGATION AND YOUR EXCLUSIVE REMEDY under this Limited Warranty and, to the extent permitted by law, any warranty or condition implied by law, shall be the repair or replacement of parts, without charge, which are defective in material or workmanship and which have not been misused, carelessly handled, or repaired by persons other than Seller or Authorized Service Station. To make a claim under this Limited Warranty, you must return the complete product, transportation prepaid, to any SKIL Factory Service Center or Authorized Service Station. For Authorized SKIL Power Tool Service Stations, please visit www.Registermyskil.com or call 1-877-SKIL-999 (1-877-754-5999).

THIS LIMITED WARRANTY DOES NOT APPLY TO ACCESSORY ITEMS SUCH AS CIRCULAR SAW BLADES, DRILL BITS, ROUTER BITS, JIGSAW BLADES, SANDING BELTS, GRINDING WHEELS AND OTHER RELATED ITEMS.

ANY IMPLIED WARRANTIES APPLICABLE TO A PRODUCT SHALL BE LIMITED IN DURATION EQUAL TO THE DURATION OF THE EXPRESS WARRANTIES APPLICABLE TO SUCH PRODUCT, AS SET FORTH IN THE FIRST PARAGRAPH ABOVE. SOME STATES IN THE U.S., SOME CANADIAN PROVINCES DO NOT ALLOW LIMITATIONS ON HOW LONG AN IMPLIED WARRANTY LASTS, SO THE ABOVE LIMITATION MAY NOT APPLY TO YOU.

IN NO EVENT SHALL SELLER BE LIABLE FOR ANY INCIDENTAL OR CONSEQUENTIAL DAMAGES (INCLUDING BUT NOT LIMITED TO LIABILITY FOR LOSS OF PROFITS) ARISING FROM THE SALE OR USE OF THIS PRODUCT. SOME STATES IN THE U.S. AND SOME CANADIAN PROVINCES DO NOT ALLOW THE EXCLUSION OR LIMITATION OF INCIDENTAL OR CONSEQUENTIAL DAMAGES, SO THE ABOVE LIMITATION OR EXCLUSION MAY NOT APPLY TO YOU.

THIS LIMITED WARRANTY GIVES YOU SPECIFIC LEGAL RIGHTS, AND YOU MAY ALSO HAVE OTHER RIGHTS WHICH VARY FROM STATE TO STATE IN THE U.S., PROVINCE TO PROVINCE IN CANADA AND FROM COUNTRY TO COUNTRY.

THIS LIMITED WARRANTY APPLIES ONLY TO PRODUCTS SOLD WITHIN THE UNITED STATES OF AMERICA, CANADA AND THE COMMONWEALTH OF PUERTO RICO. FOR WARRANTY COVERAGE WITHIN OTHER COUNTRIES, CONTACT YOUR LOCAL SKIL DEALER OR IMPORTER.

© Chervon North America, 1203 E. Warrenville Rd, Naperville, IL 60563.

08/19

SKIL

Owner's Manual

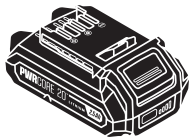
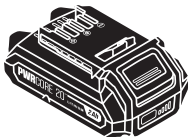

Model: BY519701 / BY519703 / BY519601 / BY519603

PWRCORE 20™ 20V Lithium Battery with Fuel Gauge

⚠ WARNING: To reduce the risk of injury, the user must read and understand the Owner's Manual before using this product. Save these instructions for future reference.



For Customer Service
Pour le service à la clientèle
Servicio al cliente

1-877-SKIL-999 OR **www.skil.com**

TABLE OF CONTENTS

Safety Instructions	3-6
Symbols	7-12
Get to Know Your Battery	13
Specifications	13
Operating Instructions	14-16
Maintenance	17-18
Battery Care	18
Battery Disposal	19
Limited Warranty of SKIL Battery Pack	20-21

SAFETY INSTRUCTIONS

 WARNING Read all safety warnings, instructions, illustrations and specifications. Failure to follow all instructions listed below may result in electric shock, fire and/or serious injury.

SAVE ALL WARNINGS AND INSTRUCTIONS FOR FUTURE REFERENCE.

The term “power tool” in the warnings refers to your mains-operated (corded) power tool or battery-operated (cordless) power tool.

Work area safety

Keep work area clean and well lit. Cluttered or dark areas invite accidents.

Do not operate power tools in explosive atmospheres, such as in the presence of flammable liquids, gases or dust. Power tools create sparks which may ignite the dust or fumes.

Electrical safety

Do not expose power tools to rain or wet conditions. Water entering a power tool will increase the risk of electric shock.

Battery tool use and care

Recharge only with the charger specified by the manufacturer. A charger that is suitable for one type of battery pack may create a risk of fire when used with another battery pack.

Use power tools only with specifically designated battery packs. Use of any other battery packs may create a risk of injury and fire.

When battery pack is not in use, keep it away from other metal objects, like paper clips, coins, keys, nails, screws or other small metal objects, that can make a connection from one terminal to another. Shorting the battery terminals together may cause burns or a fire.

Under abusive conditions, liquid may be ejected from the battery; avoid contact. If contact accidentally occurs, flush with water. If liquid contacts eyes, additionally seek medical help.

Liquid ejected from the battery may cause irritation or burns.

Do not use a battery pack or tool that is damaged or modified.

Damaged or modified batteries may exhibit unpredictable behaviour resulting in fire, explosion or risk of injury.

Do not expose a battery pack or tool to fire or excessive temperature. Exposure to fire or temperature above 265 °F may cause explosion.

Follow all charging instructions and do not charge the battery pack or tool outside the temperature range specified in the instructions. Charging improperly or at temperatures outside the specified range may damage the battery and increase the risk of fire.

Service

Have your power tool serviced by a qualified repair person using only identical replacement parts. This will ensure that the safety of the power tool is maintained.

Never service damaged battery packs. Service of battery packs should only be performed by the manufacturer or authorized service providers.

Specific Safety Rules

Before using battery, read all instructions and cautionary markings on (1) battery charger, (2) battery pack, and (3) product using battery.

Risk of fire and burns. Do not recharge, disassemble, heat above 100 °C(212 °F), or incinerate. Keep battery out of reach of children and in original package until ready to use.

Battery tools do not have to be plugged into an electrical outlet; therefore, they are always in operating condition. Be aware of possible hazards when not using your battery tool or when changing accessories.

Do not place battery tools or their batteries near fire or heat.

Charge battery pack within the required temperature range.

Store charger and battery pack in locations where temperature is within the recommended storage temperature range. This is important to prevent serious damage to the battery cells.

Do not crush, drop or damage the battery pack. Do not use a battery pack or charger that has been dropped or received a sharp blow. A damaged battery is subject to explosion. Properly dispose of a dropped or damaged battery immediately.

Do not insert battery pack in charger if battery pack case is cracked. Using damaged battery pack may result in electric shock or fire.

Batteries vent hydrogen gas and can explode in the presence of a source of ignition such as a pilot light. To reduce the risk of serious personal injury, never use any cordless product in the presence of open flame. An exploded battery can propel debris and chemicals. If exposed, flush with water immediately.

Do not recharge battery in damp or wet environment. Do not expose charger to rain or snow. Water entering battery charger may result in electric shock or fire.

Do not store outside or in vehicles.

Do not store battery pack in charger. Battery pack stored in charger over a long period of time could lead to battery pack damage and fire.

Battery leakage may occur under extreme usage or temperature conditions. Avoid contact with skin and eyes. The battery liquid is caustic and could cause chemical burns to tissues. If liquid comes in contact with skin, wash quickly with soap and water. If the liquid contacts your eyes, flush them with water for a minimum of 10 minutes and seek medical attention.

Do not let gasoline, oils, petroleum-based products, etc. come in contact with plastic parts. They contain chemicals that can damage, weaken or destroy plastic.

Do not touch the uninsulated portion of output connector or uninsulated battery terminal. There is a risk of electric shock.

Replace battery pack if a substantial drop in operating time per charge is observed. Battery pack may be nearing the end of its life.

Symbols

Safety Symbols

The purpose of safety symbols is to attract your attention to possible dangers. The safety symbols and the explanations with them deserve your careful attention and understanding. The symbol warnings do not, by themselves, eliminate any danger. The instructions and warnings they give are no substitutes for proper accident prevention measures.

 **WARNING** Be sure to read and understand all safety instructions in this Owner's Manual, including all safety alert symbols such as "**DANGER**," "**WARNING**," and "**CAUTION**" before using this tool. Failure to following all instructions listed below may result in electric shock, fire, and/or serious personal injury.

The definitions below describe the level of severity for each signal word. Please read the manual and pay attention to these symbols.



This is the safety alert symbol. It is used to alert you to potential personal injury hazards. Obey all safety messages that follow this symbol to avoid possible injury or death.

 **DANGER**

DANGER indicates a hazardous situation which, if not avoided, will result in death or serious injury.

 **WARNING**

WARNING indicates a hazardous situation which, if not avoided, could result in death or serious injury.



CAUTION, used with the safety alert symbol, indicates a hazardous situation which, if not avoided, will result in minor or moderate injury.

Damage Prevention and Information Messages

These inform the user of important information and/or instructions that could lead to equipment or other property damage if they are not followed. Each message is preceded by the word “NOTICE”, as in the example below:

NOTICE: Equipment and/or property damage may result if these instructions are not followed.













The operation of any power tools can result in foreign objects being thrown into your eyes, which can result in severe eye damage. Before beginning power tool operation, always wear safety goggles or safety glasses with side shields and a full face shield when needed. We recommend a Wide Vision Safety Mask for use over eyeglasses or standard safety glasses with side shields. Always use eye protection which is marked to comply with ANSI Z87.1.

SYMBOLS (CONTINUED)

IMPORTANT: Some of the following symbols may be used on your tool. Please study them and learn their meaning. Proper interpretation of these symbols will allow you to operate the tool better and more safely.





Symbol	Name	Designation/Explanation
V	Volts	Voltage (potential)
A	Amperes	Current
Hz	Hertz	Frequency (cycles per second)
W	Watt	Power
kg	Kilograms	Weight
min	Minutes	Time
s	Seconds	Time
Wh	Watt-hours	Battery capacity
Ah	Ampere-Hours	Battery capacity
Ø	Diameter	Size of drill bits, grinding wheels, etc.
n_0	No load speed	Rotational speed, at no load
n	Rated speed	Maximum attainable speed
.../min	Revolutions or reciprocation per minute	Revolutions, strokes, surface speed, orbits, etc. per minute
0	Off position	Zero speed, zero torque...





Symbol	Name	Designation/Explanation
1,2,3,... I,II,III,	Selector settings	Speed, torque or position settings. Higher number means greater speed
	Infinitely variable selector with off	Speed is increasing from 0 setting
	Arrow	Action in the direction of arrow
	Alternating current	Type or a characteristic of current
	Direct current	Type or a characteristic of current
	Alternating or direct current	Type or a characteristic of current
	Class II tool	Designates Double Insulated Construction tools.
	Earthing terminal	Grounding terminal
	Li-ion RBRC seal	Designates Li-ion battery recycling program
	Ni-Cad RBRC seal	Designates Ni-Cad battery recycling program
	Read manual symbol	Alerts user to read manual

Symbol	Name	Designation/Explanation
	Wear eye protection symbol	Always wear safety goggles or safety glasses with side shields and a full face shield when operating this product.

SYMBOLS (CERTIFICATION INFORMATION)

IMPORTANT: Some of the following symbols for certification information may be used on your tool. Please study them and learn their meaning. Proper interpretation of these symbols will allow you to operate the tool better and more safely.

Symbol	Designation/Explanation
	This symbol designates that this tool is listed by Underwriters Laboratories.
	This symbol designates that this tool is recognized by Underwriters Laboratories.
	This symbol designates that this tool is listed by Underwriters Laboratories, to United States and Canadian Standards.
	This symbol designates that this tool is listed by the Canadian Standards Association.

Symbol	Designation/Explanation
	<p>This symbol designates that this tool is listed by the Canadian Standards Association, to United States and Canadian Standards.</p>
	<p>This symbol designates that this tool is listed by the Intertek Testing Services, to United States and Canadian Standards.</p>
	<p>This symbol designates that this tool complies to NOM Mexican Standards.</p>
	<p>This symbol designates that this tool is listed by the California Energy Commission.</p>

GET TO KNOW YOUR BATTERY

PWRCORE 20™ Lithium Battery Pack

Fig. 1

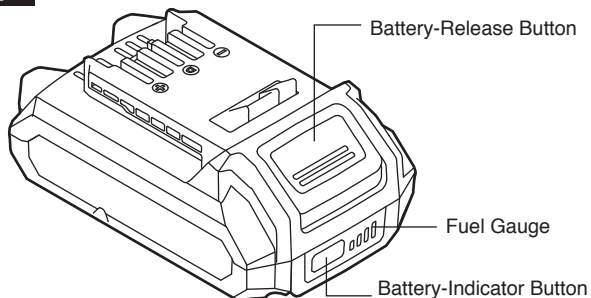

SPECIFICATIONS

Model No.	SKIL BY519701	SKIL BY519703	SKIL BY519601	SKIL BY519603
Battery Capacity	2Ah	2.5Ah	4Ah	5Ah
Battery Voltage	20 V			
Recommended Charging Temperature	41°F(5°C) ~ 104°F(40°C)			
Recommended Storage Temperature	32°F (0°C) ~104°F (40°C)			



WARNING

The batteries listed above can only be charged with SKIL SC535801, QC536001 chargers.

Note: Use of chargers or battery packs not sold by SKIL will void the warranty.

OPERATING INSTRUCTIONS

⚠ WARNING To reduce the risk of fire, personal injury, and product damage due to a short circuit, never immerse your charger or battery pack in fluid or allow a fluid to flow inside them. Corrosive or conductive fluids, such as seawater, certain industrial chemicals, and bleach or bleach-containing products, etc., can cause a short circuit.

When to Charge the Battery Pack

It is not necessary to run down the battery pack charge before recharging. The Lithium-Ion battery can be charged at any time and will not develop a “memory” when charged after only a partial discharge.

Remove the battery pack from the tool when it is convenient for you and your job.

“Top off” the battery pack charge by charging it for a time before starting a big job or use for long period of use.

How to Charge the Battery Pack

NOTICE: The Lithium battery pack is shipped partially charged.

Before using it the first time, fully charge the battery pack.

- Charge the battery pack with the correct charger.
- Connect the charger to a power supply. The red Defect Indicator and green Charging Indicator will shine for one second and then go out, indicating that the charger self-inspection is completed.

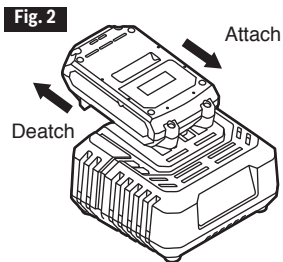

- c. Align the raised ribs of the battery pack with the slot in the charger.
- d. Insert the battery pack into the charger (Fig. 2).
- e. The charger will communicate with the battery pack to evaluate the condition of the battery pack.
- f. The charger will charge the battery pack automatically.

Please refer to the charger manual for detailed charging operation.

NOTICE: If the battery pack cannot accept a charge, the contacts of the charger or battery pack may be contaminated. Clean the contacts of the charger or battery pack (e. g., by inserting and removing the battery several times or by cleaning with a cotton swab and alcohol), replace a new charger or replace the battery pack, as required.

Defective Battery Pack

If the charger detects a problem, the red Defect Indicator will begin flashing. Remove and re-insert the battery pack in the charger. If the Defect Indicator flashes a second time, try charging a different battery pack.

- a. If a different battery pack charges normally, have the first defective battery pack serviced by an Authorized SKIL Service Station.
 - b. If a different battery pack also indicates “defective,” the charger may be defective. Have the charger serviced by an Authorized SKIL Service Station.
-

Fuel Gauge (Fig.3)

The four LEDs on the front housing of the battery indicate the current battery capacity when the battery-indicator button is depressed.

If the first LED on the Fuel Gauge flashes slowly when the battery-indicator button is depressed, this indicates a low charge level. Recharge the battery.

If the first and third LED on the fuel gauge rapidly flash green when the battery-indicator button is depressed, this indicates that the battery is too hot. Cool the battery pack under air flow.

To Attach/Detach Battery Pack

Follow the instructions in the Owner's Manual for the individual SKIL tool.

Fig. 3 Battery-Indicator Button

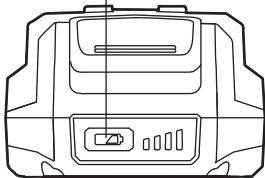

MAINTENANCE

Service

⚠ WARNING Preventive maintenance performed by unauthorized personnel may result in misplacing of internal wires and components which could cause serious hazard. We recommend that all tool service be performed by a SKIL Factory Service Center or Authorized SKIL Service Station.

General Maintenance

⚠ WARNING When servicing, use only identical replacement parts. Use of any other parts could create a hazard or cause product damage.

Periodically inspect the entire product for damaged, missing, or loose parts such as screws, nuts, bolts, caps, etc. Tighten securely all fasteners and caps and do not operate this product until all missing or damaged parts are replaced. Please contact customer service or an authorized service center for assistance.

⚠ WARNING To avoid serious personal injury, always remove the battery pack from the charger/tool when cleaning or performing any maintenance.

Cleaning

⚠ WARNING The tool may be cleaned most effectively with compressed dry air. **Always wear safety goggles when cleaning tools with compressed air.** Do not attempt to clean by inserting pointed objects through openings.

⚠ WARNING Certain cleaning agents and solvents damage plastic parts. Some of these are: gasoline, carbon tetrachloride, chlorinated cleaning solvents, ammonia and household detergents that contain ammonia.

Storage

Store the tool indoors in a place that is inaccessible to children.
Keep away from corrosive agents.

BATTERY CARE

 **WARNING** When batteries are not in tool or charger, keep them away from metal objects. For example, to protect terminals from shorting DO NOT place batteries in a tool box or pocket with nails, screws, keys, etc. Fire or injury may result.

DO NOT PUT BATTERIES INTO FIRE OR EXPOSE TO HIGH HEAT. They may explode.

BATTERY DISPOSAL

⚠ WARNING Do not attempt to disassemble the battery or remove any component projecting from the battery terminals. Fire or injury may result. Prior to disposal, protect exposed terminals with heavy insulating tape to prevent shorting.

Lithium-Ion Batteries: If equipped with a lithium-ion battery, the battery must be collected, recycled or disposed of in an environmentally sound manner.



The EPA certified RBRC Battery Recycling Seal on the lithium-ion (Li-ion) battery indicates Chervon North America is voluntarily participating in an industry program to collect and recycle these batteries at the end of their useful life, when taken out of service in the United States or Canada. The RBRC program provides a convenient alternative to placing used Li-ion batteries into the trash or the municipal waste stream, which may be illegal in your area.

Please call 1-800-8-BATTERY for information on Li-ion battery recycling and disposal bans/restrictions in your area, or return your batteries to a SKIL Service Center for recycling. Chervon North America's involvement in this program is part of our commitment to preserving our environment and conserving our natural resources.

LIMITED WARRANTY OF SKIL CONSUMER TOOLS

2 YEAR LIMITED WARRANTY- LEGAL

Chervon North America, Inc. ("Seller") warrants to the original purchaser only, that all SKIL consumer BATTERIES AND CHARGERS will be free from defects in material or workmanship for a period of two years from date of purchase.

Product registration can be completed online at www.Registermyskil.com. Original purchasers should also retain their receipt as proof of purchase.

Notwithstanding the foregoing, if a SKIL consumer portable power tool is used for industrial, professional or commercial purposes, the foregoing warranty will apply for a duration of ninety days, regardless of registration.

SELLER'S SOLE OBLIGATION AND YOUR EXCLUSIVE REMEDY under this Limited Warranty and, to the extent permitted by law, any warranty or condition implied by law, shall be the repair or replacement of parts, without charge, which are defective in material or workmanship and which have not been misused, carelessly handled, or repaired by persons other than Seller or Authorized Service Station. To make a claim under this Limited Warranty, you must return the complete product, transportation prepaid, to any SKIL Factory Service Center or Authorized Service Station. For Authorized SKIL Power Tool Service Stations, please visit www.Registermyskil.com or call 1-877-SKIL-999 (1-877-754-5999).

THIS LIMITED WARRANTY DOES NOT APPLY TO ACCESSORY ITEMS SUCH AS CIRCULAR SAW BLADES, DRILL BITS.

ANY IMPLIED WARRANTIES APPLICABLE TO A PRODUCT SHALL BE LIMITED IN DURATION EQUAL TO THE DURATION OF THE EXPRESS WARRANTIES APPLICABLE TO SUCH PRODUCT, AS SET FORTH IN THE FIRST PARAGRAPH ABOVE. SOME STATES IN THE U.S., SOME CANADIAN PROVINCES DO NOT ALLOW LIMITATIONS ON HOW LONG AN IMPLIED WARRANTY LASTS, SO THE ABOVE LIMITATION MAY NOT APPLY TO YOU.

IN NO EVENT SHALL SELLER BE LIABLE FOR ANY INCIDENTAL OR CONSEQUENTIAL DAMAGES (INCLUDING BUT NOT LIMITED TO LIABILITY FOR LOSS OF PROFITS) ARISING FROM THE SALE OR USE OF THIS PRODUCT. SOME STATES IN THE U.S. AND SOME CANADIAN PROVINCES DO NOT ALLOW THE EXCLUSION OR LIMITATION OF INCIDENTAL OR CONSEQUENTIAL DAMAGES, SO THE ABOVE LIMITATION OR EXCLUSION MAY NOT APPLY TO YOU.

THIS LIMITED WARRANTY GIVES YOU SPECIFIC LEGAL RIGHTS, AND YOU MAY ALSO HAVE OTHER RIGHTS WHICH VARY FROM STATE TO STATE IN THE U.S., PROVINCE TO PROVINCE IN CANADA AND FROM COUNTRY TO COUNTRY.

THIS LIMITED WARRANTY APPLIES ONLY TO PRODUCTS SOLD WITHIN THE UNITED STATES OF AMERICA, CANADA AND THE COMMONWEALTH OF PUERTO RICO. FOR WARRANTY COVERAGE WITHIN OTHER COUNTRIES, CONTACT YOUR LOCAL SKIL DEALER OR IMPORTER.

© Chervon North America, 1203 E. Warrenville Rd, Naperville, IL 60563.

01/19

SKIL

Owner's Manual

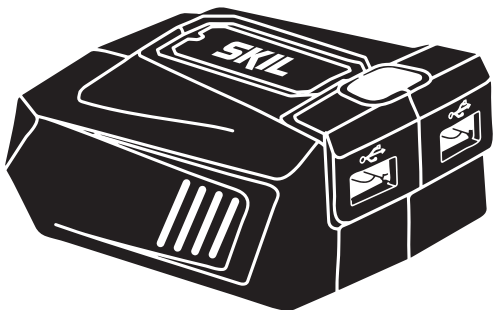

Model: AD592301

20V PWR Assist USB Charging Adapter

⚠ WARNING: To reduce the risk of injury, the user must read and understand the Owner's Manual before using this product. Save these instructions for future reference.



For Customer Service
Pour le service à la clientèle
Servicio al cliente

1-877-SKIL-999 OR www.skil.com

TABLE OF CONTENTS

Safety Instructions	3-5
Symbols	6-10
Get to Know Your USB Charging Adapter	11-12
Specifications	11
Operating Instructions	13-15
Maintenance	16-17
Troubleshooting	17
Limited Warranty of SKIL Cordless Tool	18-19

SAFETY INSTRUCTIONS

IMPORTANT SAFETY INSTRUCTIONS



Read all safety warnings and instructions.

Failure to follow the warnings and instructions may result in electric shock, fire and/or serious injury.

Save these instructions - This operator's manual contains important safety and operating instructions for the 20V USB Charging Adapter. Before using the adapter, read this operator's manual, your battery pack and charger operator's manual, and all labels on the battery pack, charger and adapter.

Work area safety

Avoid dangerous environments. Do not use in rain, snow, damp or wet locations. Do not use in the presence of explosive atmospheres (gaseous fumes, dust or flammable materials) because sparks may be generated when inserting or removing battery pack, possibly causing fire.

Electrical safety

Do not use an extension cord with the adapter. Using an extension cord could result in the risk of fire and electrical shock.

Personal safety

Follow adapter manufacturers' instructions regarding operation and power. Use of the adapter different from those intended could result in a hazardous situation.

Use the correct adapter for the application.

Stay alert, watch what you are doing and use common sense when operating adapter. Do not use while you are tired or under the influence of drugs, alcohol or medication. A moment of inattention may result in serious personal injury.

Use and care

Remove the battery pack or any other devices from the adapter before storing. Such preventive safety measures reduce the risk of starting the adapter accidentally.

Prevent unintentional starting. Ensure the switch is in the off-position before connecting to battery pack, picking up or carrying the adapter. Carrying the adapter with your finger on the switch or energizing adapter that have the switch on invites accidents.

Store idle adapter and battery pack out of the reach of children and do not allow persons unfamiliar with the adapter, battery pack or these instructions to operate them. Adapters and battery packs are dangerous in the hands of untrained users.

Disconnect the battery pack from the adapter before making any adjustments, changing accessories, maintenance, or storing adapter.

Check for misalignment, breakage of parts and any other condition that may affect the adapter operation. If damaged, have the adapters repaired before use. Many accidents are caused by poorly maintained adapters.

Use the adapter in accordance with these instructions, taking into account the working conditions and the work to be performed. Use of the adapter for operations different from those intended could result in a hazardous situation.

Keep adapter and battery pack away from other metal objects like paper clips, coins, keys, nails, screws, or other small metal objects that can make a connection from one terminal to another. Shorting the terminals together may cause burns or a fire.

Under abusive conditions, liquid may be ejected from the battery; avoid contact. If contact accidentally occurs, flush with water. If liquid contacts eyes, additionally seek medical help. Liquid ejected from the battery may cause irritation or burns.

Do not use a battery pack or adapter that is damaged or modified. Damaged or modified batteries may exhibit unpredictable behavior resulting in fire, explosion or risk of injury.

Battery use and care

Adapter is rated for 20 V DC only. Use only appropriate battery packs as in adapter the specification mentioned. Use of any other battery packs may create a risk of injury and fire.

Recharge only with the charger specified by the manufacturer. A charger that is suitable for one type of battery pack may create a risk of fire when used with another battery pack.

To reduce the risk of electric shock, always remove battery pack before cleaning or maintenance.

Do not expose a battery pack or adapter to fire or excessive temperature. Exposure to fire or temperature above 265°F (130°C) may cause explosion.

Follow all charging instructions and do not charge the battery pack or adapter outside of the temperature range specified in the instructions. Charging improperly or at temperatures outside of the specified range may damage the battery and increase the risk of fire.

Service

Do not disassemble. Incorrect reassembly may result in the risk of electric shock or fire. If it is damaged, take it to a specified service facility.

Store in a cool, dry place. Do not store where temperatures may exceed 104°F (40°C) such as in direct sunlight, a vehicle or metal building during the summer.

Maintain labels and nameplates. These carry important information. If unreadable or missing, contact a specified service facility for a free replacement.

Have servicing performed by a qualified repair person using only identical replacement parts. This will ensure that the safety of the product is maintained.

Do not modify or attempt to repair the adapter or the battery pack except as indicated in the instructions for use and care.



SAVE THESE INSTRUCTIONS

SYMBOLS

Safety Symbols

The purpose of safety symbols is to attract your attention to possible dangers. The safety symbols and the explanations with them deserve your careful attention and understanding. The symbol warnings do not, by themselves, eliminate any danger. The instructions and warnings they give are no substitutes for proper accident prevention measures.

 **WARNING** Be sure to read and understand all safety instructions in this Owner's Manual, including all safety alert symbols such as “**DANGER**,” “**WARNING**,” and “**CAUTION**” before using this tool. Failure to following all instructions listed below may result in electric shock, fire, and/or serious personal injury.

The definitions below describe the level of severity for each signal word. Please read the manual and pay attention to these symbols.	
	This is the safety alert symbol. It is used to alert you to potential personal injury hazards. Obey all safety messages that follow this symbol to avoid possible injury or death.
	DANGER indicates a hazardous situation which, if not avoided, will result in death or serious injury.
	WARNING indicates a hazardous situation which, if not avoided, could result in death or serious injury.



CAUTION, used with the safety alert symbol, indicates a hazardous situation which, if not avoided, will result in minor or moderate injury.

Damage Prevention and Information Messages

These inform the user of important information and/or instructions that could lead to equipment or other property damage if they are not followed. Each message is preceded by the word “NOTICE”, as in the example below:





NOTICE: Equipment and/or property damage may result if these instructions are not followed







The operation of any power tools can result in foreign objects being thrown into your eyes, which can result in severe eye damage. Before beginning power tool operation, always wear safety goggles or safety glasses with side shields and a full face shield when needed. We recommend a Wide Vision Safety Mask for use over eyeglasses or standard safety glasses with side shields. Always use eye protection which is marked to comply with ANSI Z87.1.

SYMBOLS (CONTINUED)



IMPORTANT: Some of the following symbols may be used on your tool. Please study them and learn their meaning. Proper interpretation of these symbols will allow you to operate the tool better and more safely.

Symbol	Name	Designation/Explanation
V	Volts	Voltage (potential)
A	Amperes	Current
Hz	Hertz	Frequency (cycles per second)
W	Watt	Power
kg	Kilograms	Weight
min	Minutes	Time
s	Seconds	Time
Wh	Watt-hours	Battery capacity
Ah	Ampere-Hours	Battery capacity
	Alternating current	Type or a characteristic of current
	Direct current	Type or a characteristic of current
	Alternating or direct current	Type or a characteristic of current
	Class II construction	Designates Double Insulated Construction tools.

Symbol	Name	Designation/Explanation
	Earthing terminal	Grounding terminal
	Li-ion RBRC seal	Designates Li-ion battery recycling program
	Ni-Cad RBRC seal	Designates Ni-Cad battery recycling program
	Read manual symbol	Alerts user to read manual
	Wear eye protection symbol	Alerts user to wear eye protection

SYMBOLS (CERTIFICATION INFORMATION)

IMPORTANT: Some of the following symbols for certification information may be used on your tool. Please study them and learn their meaning. Proper interpretation of these symbols will allow you to operate the tool better and more safely.

Symbol	Designation/Explanation
	This symbol designates that this tool is listed by Underwriters Laboratories.
	This symbol designates that this tool is recognized by Underwriters Laboratories.

Symbol	Designation/Explanation
	<p>This symbol designates that this tool is listed by Underwriters Laboratories, to United States and Canadian Standards.</p>
	<p>This symbol designates that this tool is listed by the Canadian Standards Association.</p>
	<p>This symbol designates that this tool is listed by the Canadian Standards Association, to United States and Canadian Standards.</p>
	<p>This symbol designates that this tool is listed by the Intertek Testing Services, to United States and Canadian Standards.</p>
	<p>This symbol designates that this tool complies to NOM Mexican Standards.</p>
	<p>This symbol designates that this tool is listed by the California Energy Commission.</p>

GET TO KNOW YOUR USB CHARGING ADAPTER

SKIL PWRCORE 20™ USB Charging Adapter

Fig. 1

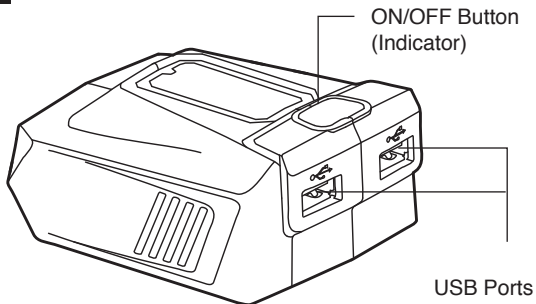

SPECIFICATIONS

Rated input	20V d.c.	
Output voltage	5.1V d.c.	
Output current	Max. 2.1 A (each port) Max. 3.6 A (in total)	
Battery Pack Compatibility	2.0Ah	SKIL BY519701、 SKIL BY519702
	2.5Ah	SKIL BY519703
	4.0Ah	SKIL BY519601
	5.0Ah	SKIL BY519603

Charger Compatibility	SKIL SC535801
Recommended Charging Temperature	41°F(5°C) ~ 104°F(40°C)
Recommended Adapter and Battery Pack Storage Temperature	32°F (0°C)~104°F (40°C)

 *WARNING* This USB charging adapter must be used only with the battery packs and charger listed above.

NOTICE: Please refer to the battery and charger manuals for detailed operating information.

OPERATING INSTRUCTIONS

⚠ WARNING To reduce the risk of fire, personal injury, and product damage due to a short circuit, never immerse your tool or battery pack in fluid or allow a fluid to flow inside them. Corrosive or conductive fluids, such as seawater, certain industrial chemicals, and bleach or bleach-containing products, etc, can cause a short circuit.

⚠ WARNING If any parts are damaged or missing, do not operate this product until the parts are replaced. Use of this product with damaged or missing parts could result in serious personal injury.

⚠ WARNING Do not attempt to modify this product or create accessories not recommended for use with this product. Any such alteration or modification is misuse and could result in a hazardous condition leading to possible serious injury.

⚠ WARNING Do not use USB charging adaptor in explosive atmospheres, such as in the presence of flammable liquids, gases or dust.

⚠ CAUTION This USB charging adaptor is used to charge cell phone, tablet, e-book and other USB device.

To Attach/Detach Battery Pack (Fig. 2)

- To attach the battery pack:
Align the raised rib on the battery pack with the grooves of the adapter, and then slide the battery pack onto the adapter.

Fig. 2

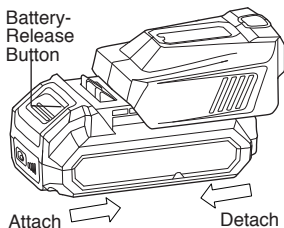

- b. To detach the battery pack:

Depress the battery-release button, located on the front of the battery pack, to release the battery pack. Pull the battery pack out and remove it from the adapter.

NOTICE: When assembling the battery pack to the adapter, be sure that the raised rib on the battery pack aligns with the groove inside the adapter and that the latches snap into place properly. Improper attachment of the battery pack can cause damage to internal components.

NOTICE: Battery products are always in operating condition. Therefore, always remove the adapter from the battery when it is not in use.

ON/OFF Button (Fig. 3)

- a. To turn on the adapter, press the ON/OFF button. The indicator will shine green, indicating that the adapter is active.
- b. To turn off the adapter, press the ON/OFF button. The indicator will be off to indicate that the adapter is deactivated

NOTICE: When the adapter has not been in use for approximately 3 hours, it will automatically turn off and the green light will be off.

Fig. 3

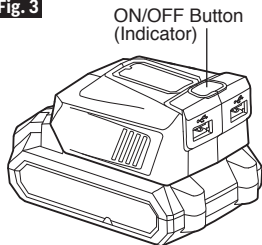

Using with a USB Device (Fig. 4)

Fig. 4

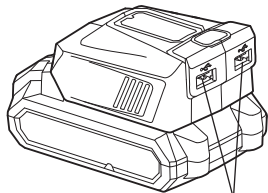

When a battery pack is installed, place it on a surface to avoid damage to the adapter during operation.

- a. Insert a battery pack into the adapter.
- b. Plug a USB cable (not included) into one of the USB ports in the adapter and plug the other end of the cable into your device.
- c. Press the ON/OFF button to begin charging the USB device.
- d. The USB device will fully charge.
- e. After charging is completed, if left connected with the adapter, it will automatically shut off after approximately 3 hours, and the charging process will stop.
- f. To reactivate the adapter, press the ON/OFF button.
- g. When not using or after charging, remove the USB cable and remove the adapter from the battery.

NOTICE:

- The maximum current draw is 2.1A for each port and 3.6A total for both ports.
- If the device draws more than the rated output of the ports, the adapter will shut off to protect the battery pack. To reactivate the adapter, remove the device and press the ON/OFF button.
- Charging time is dependent upon the device.
- The adapter may warm with several continuous cycles; this is part of its normal operation. Always use the adapter in a well-ventilated area.

MAINTENANCE

⚠ WARNING To avoid serious personal injury, always remove the battery pack from the tool when cleaning or performing any maintenance.

Service

⚠ WARNING Preventive maintenance performed by unauthorized personnel may result in misplacing of internal wires and components which could cause serious hazard. We recommend that all tool service be performed by a SKIL Factory Service Center or Authorized SKIL Service Station.

General Maintenance

⚠ WARNING When servicing, use only identical replacement parts. Use of any other parts could create a hazard or cause product damage.

Periodically inspect the entire product for damaged, missing, or loose parts such as screws, nuts, bolts, caps, etc. Tighten securely all fasteners and caps and do not operate this product until all missing or damaged parts are replaced. Please contact customer service or an authorized service center for assistance.

Cleaning

⚠ WARNING The tool may be cleaned most effectively with a soft, dry cloth. Keep the power ports clean, dry and free of oil or grease. Do not attempt to clean by inserting pointed objects through openings.

⚠ WARNING Certain cleaning agents and solvents damage plastic parts. Some of these are: gasoline, carbon tetrachloride, chlorinated cleaning solvents, ammonia and house hold detergents that contain ammonia.

Storage

Store the tool indoors in a place that is inaccessible to children.
Keep away from corrosive agents.

TROUBLESHOOTING

Problem	Cause	Remedy
The USB charging adapter does not work.	<ol style="list-style-type: none"><li data-bbox="310 362 587 425">1. Low battery capacity.<li data-bbox="310 439 587 531">2. The device draws more than the rated output of the ports.	<ol style="list-style-type: none"><li data-bbox="601 362 928 391">1. Charge the battery.<li data-bbox="601 439 928 531">2. Remove the device and turn the adapter on again.

LIMITED WARRANTY OF SKIL CONSUMER TOOLS

5 YEAR LIMITED WARRANTY- LEGAL

Chervon North America, Inc. ("Seller") warrants to the original purchaser only, that all SKIL consumer TOOLS will be free from defects in material or workmanship for a period of five years from date of purchase, if original purchaser registers the product within 30 days from purchase. BATTERIES AND CHARGERS are warranted for 2 years. Product registration can be completed online at www.Registermyskil.com. Original purchasers should also retain their receipt as proof of purchase. THE FIVE-YEAR WARRANTY PERIOD FOR TOOLS IS CONDITIONED ON REGISTRATION OF THE PRODUCT WITHIN 30 DAYS OF PURCHASE. If original purchasers do not register their product timely, the foregoing limited warranty will apply for a duration of three years for tools. All batteries and chargers will remain under the two-year limited warranty.

Notwithstanding the foregoing, if a SKIL consumer tool is used for industrial, professional or commercial purposes, the foregoing warranty will apply for a duration of ninety days, regardless of registration.

SELLER'S SOLE OBLIGATION AND YOUR EXCLUSIVE REMEDY under this Limited Warranty and, to the extent permitted by law, any warranty or condition implied by law, shall be the repair or replacement of parts, without charge, which are defective in material or workmanship and which have not been misused, carelessly handled, or repaired by persons other than Seller or Authorized Service Station. To make a claim under this Limited Warranty, you must return the complete product, transportation prepaid, to any SKIL Factory Service Center or Authorized Service Station. For Authorized SKIL Power Tool Service Stations, please visit www.Registermyskil.com or call 1-877-SKIL-999 (1-877-754-5999).

THIS LIMITED WARRANTY DOES NOT APPLY TO ACCESSORY ITEMS SUCH AS CIRCULAR SAW BLADES, DRILL BITS,

ROUTER BITS, JIGSAW BLADES, SANDING BELTS, GRINDING WHEELS AND OTHER RELATED ITEMS.

ANY IMPLIED WARRANTIES APPLICABLE TO A PRODUCT SHALL BE LIMITED IN DURATION EQUAL TO THE DURATION OF THE EXPRESS WARRANTIES APPLICABLE TO SUCH PRODUCT, AS SET FORTH IN THE FIRST PARAGRAPH ABOVE. SOME STATES IN THE U.S., SOME CANADIAN PROVINCES DO NOT ALLOW LIMITATIONS ON HOW LONG AN IMPLIED WARRANTY LASTS, SO THE ABOVE LIMITATION MAY NOT APPLY TO YOU.

IN NO EVENT SHALL SELLER BE LIABLE FOR ANY INCIDENTAL OR CONSEQUENTIAL DAMAGES (INCLUDING BUT NOT LIMITED TO LIABILITY FOR LOSS OF PROFITS) ARISING FROM THE SALE OR USE OF THIS PRODUCT. SOME STATES IN THE U.S. AND SOME CANADIAN PROVINCES DO NOT ALLOW THE EXCLUSION OR LIMITATION OF INCIDENTAL OR CONSEQUENTIAL DAMAGES, SO THE ABOVE LIMITATION OR EXCLUSION MAY NOT APPLY TO YOU.

THIS LIMITED WARRANTY GIVES YOU SPECIFIC LEGAL RIGHTS, AND YOU MAY ALSO HAVE OTHER RIGHTS WHICH VARY FROM STATE TO STATE IN THE U.S., PROVINCE TO PROVINCE IN CANADA AND FROM COUNTRY TO COUNTRY.

THIS LIMITED WARRANTY APPLIES ONLY TO PRODUCTS SOLD WITHIN THE UNITED STATES OF AMERICA, CANADA AND THE COMMONWEALTH OF PUERTO RICO. FOR WARRANTY COVERAGE WITHIN OTHER COUNTRIES, CONTACT YOUR LOCAL SKIL DEALER OR IMPORTER.

© Chervon North America, 1203 E. Warrenville Rd, Naperville, IL 60563.

09/18

SKIL

Owner's Manual

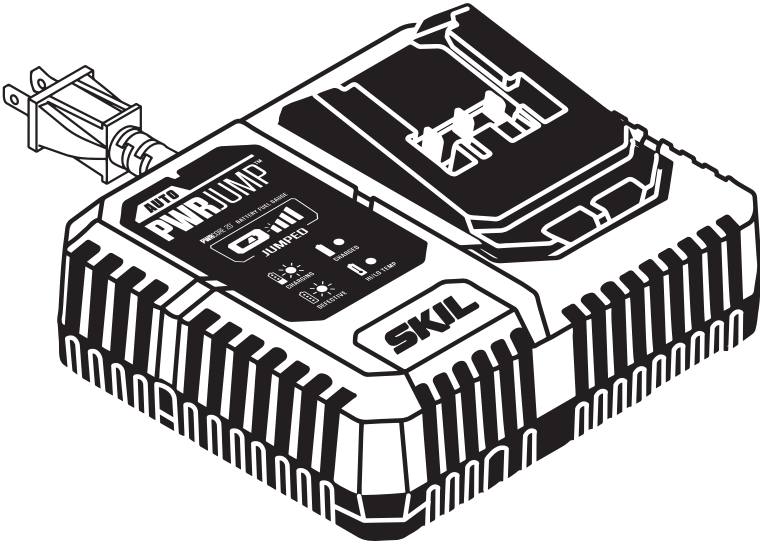

Model: QC536001

PWRCORE 20™ Charger

⚠ WARNING: To reduce the risk of injury, the user must read and understand the Owner's Manual before using this product. Save these instructions for future reference.



For Customer Service
Pour le service à la clientèle
Servicio al cliente

1-877-SKIL-999 OR **www.skil.com**

TABLE OF CONTENTS

Charger Safety Instructions	3-4
Extension Cords	4
FCC Caution	5
Symbols	6-9
Get to Know Your Charger	10
Specifications	10
Important Charging Notes	11
Operating Instructions	12-14
Maintenance	15
Troubleshooting	15
Limited Warranty of SKIL Charger	16

IMPORTANT SAFETY INSTRUCTIONS - SAVE THESE INSTRUCTIONS

⚠ DANGER TO REDUCE THE RISK OF FIRE OR ELECTRIC SHOCK, CAREFULLY FOLLOW THESE INSTRUCTIONS.

CHARGER SAFETY INSTRUCTIONS

Save these instructions. This manual contains important safety and operating instructions for battery charger model QC536001.

Before using battery charger, read all instructions and cautionary markings on battery charger, battery and product using battery.

⚠ CAUTION To reduce risk of injury, charge only SKIL rechargeable batteries listed in the manual. Other types of batteries may burst causing personal injury and damage.

Charge battery pack within the required temperature range. Store charger and battery pack in locations where temperature is within the recommended storage temperature range. This is important to prevent serious damage to the battery cells.

Do not recharge battery in damp or wet environment. Do not expose charger to rain or snow. Water entering battery charger may result in electric shock or fire.

Battery leakage may occur under extreme usage or temperature conditions. Avoid contact with skin and eyes. The battery liquid is caustic and could cause chemical burns to tissues. If liquid comes in contact with skin, wash quickly with soap and water. If the liquid contacts your eyes, flush them with water for a minimum of 10 minutes and seek medical attention.

Place charger on flat nonflammable surfaces and away from flammable materials when recharging battery pack. Carpeting and other heat insulating surfaces block proper air circulation which may cause overheating of the charger and battery pack. If smoke or melting of the charger or battery pack is observed, unplug the charger immediately and do not use the battery pack or charger. Contact customer service immediately.

Keep the cord and charger from heat to prevent damage to housing or internal parts.

Do not allow gasoline, oils, petroleum-based products, etc. to come in contact with plastic parts. These materials contain chemicals that can damage, weaken, or destroy plastic.

Make sure cord is located so that it will not be stepped on, tripped over, or otherwise subjected to damage or stress. Damaged plug and cord may result in electric shock or fire.

Disconnect the charger by pulling the plug rather than the cord. Do not operate charger with damaged cord or plug; have them replaced immediately. Damaged plug or cord may result in electric shock or fire.

Do not insert battery pack in charger if battery pack case is cracked. Using damaged battery pack may result in electric shock or fire.

Do not disassemble charger or operate the charger if it has received a sharp blow, been dropped or otherwise damaged in anyway. Incorrect reassembly or damage may result in electric shock or fire.

Before each use, check the battery charger, cable and plug. If damage is detected, do not use the battery charger. Never open the battery charger yourself, take it to a SKIL Factory Service Center, or qualified serviceman only using original spare parts. Incorrect reassembly may result in electric shock or fire.

Do not touch the uninsulated portion of output connector or uninsulated battery terminal. There is a risk of electric shock.

Do not use attachment not recommended or sold by SKIL. Using attachments not recommended may result in electric shock or fire.

Do not store battery pack in charger. Battery pack stored in charger over a long period of time could lead to battery pack damage and fire.

Unplug charger from outlet before storage, attempting any maintenance or cleaning. Such preventive safety measures reduce the risk of electric shock or fire.

Keep the battery charger clean by blowing compressed air on charger vents and wiping the charger housing with a damp cloth. Contamination may result in electric shock or fire.

Replace battery pack if a substantial drop in operating time per charge is observed. Battery pack may be nearing the end of its life.

To reduce the risk of injury, close supervision is necessary when an appliance is used near children.

Do not use outdoors.

EXTENSION CORDS

⚠ WARNING AN EXTENSION CORD SHOULD NOT BE USED UNLESS ABSOLUTELY NECESSARY. Use of improper extension cord could result in risk of fire and electrical shock. If an extension cord is used, make sure:

- The pins on plug of extension cord are the same number, size, and shape as those of plug on charger.
- The extension cord is properly wired and in good electrical condition.
- The wire size is large enough for AC ampere rating of charger as specified below:

Length of Cord (Feet)	25'	50'	100'	150'
Size of Cord (AWG)	18	16	16	14

Extension Cord Chart for 220/240 Volt Tools:	
0.75mm ² CORD	50 Meters
1.0mm ² CORD	75 Meters

- An extension cord is a temporary solution. Move the charger to a standard receptacle as soon as the job has been completed.

FCC CAUTION

1. This device complies with Part 15 of the FCC Rules. Operation is subject to the following two conditions:

- (1) This device may not cause harmful interference.
- (2) This device must accept any interference received, including interference that may cause undesired operation.

2. Changes or modifications not expressly approved by the party responsible for compliance could void the user's authority to operate the equipment.

NOTE: This equipment has been tested and found to comply with the limits for a Class B digital device, pursuant to Part 15 of the FCC Rules. These limits are designed to provide reasonable protection against harmful interference in a residential installation. This equipment generates, uses, and can radiate radio frequency energy and, if not installed and used in accordance with the instructions, may cause harmful interference to radio communications. However, there is no guarantee that interference will not occur in a particular installation. If this equipment does cause harmful interference to radio or television reception, which can be determined by turning the equipment off and on, the user is encouraged to try to correct the interference by one or more of the following measures:

- Reorient or relocate the receiving antenna.
- Increase the separation between the equipment and receiver.
- Connect the equipment into an outlet on a circuit different from that to which the receiver is connected.
- Consult the dealer or an experienced radio/TV technician for help.

 DANGER People with electronic devices, such as pacemakers, should consult their physician(s) before using this product. Operation of electrical equipment in close proximity to a heart pacemaker could cause interference or failure of the pacemaker.

SYMBOLS

Safety Symbols

The purpose of safety symbols is to attract your attention to possible dangers. The safety symbols and the explanations with them deserve your careful attention and understanding. The symbol warnings do not, by themselves, eliminate any danger. The instructions and warnings they give are no substitutes for proper accident prevention measures.

⚠ WARNING Be sure to read and understand all safety instructions in this Owner's Manual, including all safety alert symbols such as "**DANGER**," "**WARNING**," and "**CAUTION**" before using this tool. Failure to following all instructions listed below may result in electric shock, fire, and/or serious personal injury.

The definitions below describe the level of severity for each signal word. Please read the manual and pay attention to these symbols.	
	This is the safety alert symbol. It is used to alert you to potential personal injury hazards. Obey all safety messages that follow this symbol to avoid possible injury or death.
⚠ DANGER	DANGER indicates a hazardous situation which, if not avoided, will result in death or serious injury.
⚠ WARNING	WARNING indicates a hazardous situation which, if not avoided, could result in death or serious injury.
⚠ CAUTION	CAUTION, used with the safety alert symbol, indicates a hazardous situation which, if not avoided, will result in minor or moderate injury.

Damage Prevention and Information Messages

These inform the user of important information and/or instructions that could lead to equipment or other property damage if they are not followed. Each message is preceded by the word "NOTICE", as in the example below:









NOTICE: Equipment and/or property damage may result if these instructions are not followed.





⚠ WARNING The operation of any power tools can result in foreign objects being thrown into your eyes, which can result in severe eye damage. Before beginning power tool operation, always wear safety goggles or safety glasses with side shields and a full face shield when needed. We recommend a Wide Vision Safety Mask for use over eyeglasses or standard safety glasses with side shields. Always use eye protection which is marked to comply with ANSI Z87.1.

SYMBOLS (CONTINUED)





IMPORTANT: Some of the following symbols may be used on your tool. Please study them and learn their meaning. Proper interpretation of these symbols will allow you to operate the tool better and more safely.

Symbol	Name	Designation/Explanation
V	Volts	Voltage (potential)
A	Amperes	Current
Hz	Hertz	Frequency (cycles per second)
W	Watt	Power
kg	Kilograms	Weight
min	Minutes	Time
s	Seconds	Time
Wh	Watt-hours	Battery capacity
Ah	Ampere-Hours	Battery capacity
∅	Diameter	Size of drill bits, grinding wheels, etc.
n_0	No load speed	Rotational speed, at no load
n	Rated speed	Maximum attainable speed
.../min	Revolutions or reciprocation per minute	Revolutions, strokes, surface speed, orbits, etc. per minute
0	Off position	Zero speed, zero torque...
1,2,3,... I,II,III,	Selector settings	Speed, torque or position settings. Higher number means greater speed
	Infinitely variable selector with off	Speed is increasing from 0 setting
	Arrow	Action in the direction of arrow
	Alternating current	Type or a characteristic of current
	Direct current	Type or a characteristic of current
	Alternating or direct current	Type or a characteristic of current
	Class II tool	Designates Double Insulated Construction tools.
	Earthing terminal	Grounding terminal
	Li-ion RBRC seal	Designates Li-ion battery recycling program
	Ni-Cad RBRC seal	Designates Ni-Cad battery recycling program

Symbol	Name	Designation/Explanation
	Read manual symbol	Alerts user to read manual
	Wear eye protection symbol	Always wear safety goggles or safety glasses with side shields and a full face shield when operating this product.

SYMBOLS (CERTIFICATION INFORMATION)

IMPORTANT: Some of the following symbols for certification information may be used on your tool. Please study them and learn their meaning. Proper interpretation of these symbols will allow you to operate the tool better and more safely.

Symbol	Designation/Explanation
	This symbol designates that this tool is listed by Underwriters Laboratories.
	This symbol designates that this tool is recognized by Underwriters Laboratories.
	This symbol designates that this tool is listed by Underwriters Laboratories, to United States and Canadian Standards.
	This symbol designates that this tool is listed by the Canadian Standards Association.
	This symbol designates that this tool is listed by the Canadian Standards Association, to United States and Canadian Standards.
	This symbol designates that this tool is listed by the Intertek Testing Services, to United States and Canadian Standards.
	This symbol designates that this tool complies to NOM Mexican Standards.
	This symbol designates that this tool is listed by the California Energy Commission.

GET TO KNOW YOUR CHARGER

PWRCore 20™ Charger

Fig. 1

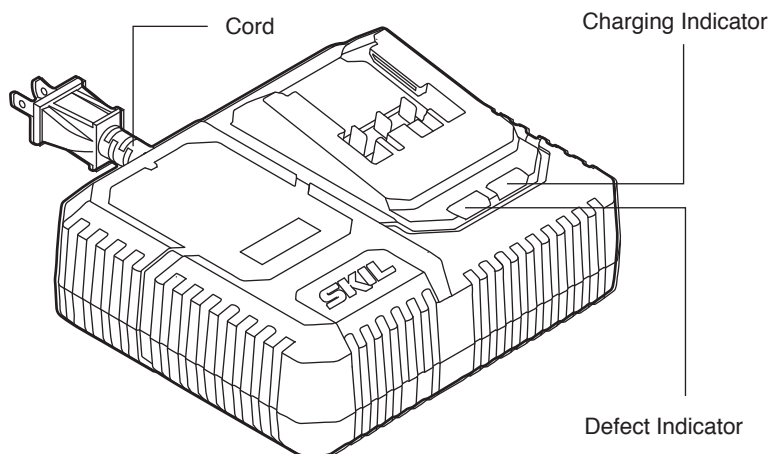

SPECIFICATIONS

Rated input	120V a.c. 60Hz 150W			
Rated output	20V			
Battery Compatibility	2Ah: SKIL BY519701 SKIL BY519702	2.5Ah: SKIL BY519703	4Ah: SKIL BY519601	5Ah: SKIL BY519603
Recommended Charging Temperature	41°F(5°C) ~ 95°F(35°C)			
Recommended Storage Temperature	32°F (0°C)~104°F (40°C)			

IMPORTANT CHARGING NOTES

1. The charger was designed to rapidly charge the battery only when the battery temperature is between 41°F (5°C) and 95°F (35°C). If the battery pack is too hot or too cold, the charger will not begin charging the battery. (This may happen if the battery pack is hot from heavy use). Once the battery temperature returns to its safe charging temperature, the charger will automatically begin charging.
2. A substantial drop in operating time per charge may mean that the battery pack is nearing the end of its life and should be replaced.
3. Remember to unplug the charger during storage.
4. If battery does not charge properly:
 - a. Check for power at the outlet by plugging another electrical device into the outlet.
 - b. Check to see if outlet is connected to a light switch that turns power “off” when the lights are turned off.
 - c. Check the battery pack terminals for dirt. Clean with a cotton swab and alcohol, if necessary.
 - d. If proper charging still does not occur, take or send the tool, battery pack and charger to your local SKIL Service Center. Please refer to the Customer Service information on the cover of this manual.

Note: Use of chargers or battery packs not sold by SKIL will void the tool warranty.

OPERATING INSTRUCTIONS

⚠ WARNING To reduce the risk of fire, personal injury, and product damage due to a short circuit, never immerse your charger or battery pack in fluid or allow a fluid to flow inside them. Corrosive or conductive fluids, such as seawater, certain industrial chemicals, and bleach or bleach-containing products, etc, can cause a short circuit.

How to Charge the Battery Pack

NOTICE: The battery pack is shipped partially charged. Before using it the first time, fully charge the battery pack. The charger charges a fully-depleted 2.0Ah battery pack to approximately 25% capacity in 5 minutes.

- a. Charge the battery pack with the correct charger.
- b. Connect the charger to a power supply. The red Defect Indicator and green Charging Indicator will shine for one second and then go out, indicating that the charger self-inspection is completed.
- c. Align the raised ribs of the battery pack with the slot in the charger.
- d. Insert the battery pack into the charger (Fig. 2).
- e. The charger will communicate with the battery pack to evaluate the condition of the battery pack.
- f. If the battery pack temperature is within the charging temperature range, the charger will automatically start charging the battery pack. The green charging indicator will flash during charging. After the charging is complete, the green charging indicator will remain green, without flashing.
- g. A flashing red defect indicator indicates a defective battery, a defective charger, or a bad connection between the battery and the charger.
- h. A solid red defect indicator indicates that the battery is warmer or colder than the optimal temperature. Remove the battery pack from the charger. If the battery is too hot, cool the battery under air flow. If the battery is too cold, place it indoors until it reaches room temperature.
- i. It is not recommended that the battery pack remain on the charger for more than 24 hours.

NOTICE: If the battery pack cannot accept a charge, the contacts of the charger or battery pack may be contaminated. Clean the contacts of the charger or battery pack (e. g., by inserting and removing the battery several times or cleaning with a cotton swab and alcohol), or replace the charger or replace the battery pack, as required.

Fig. 2

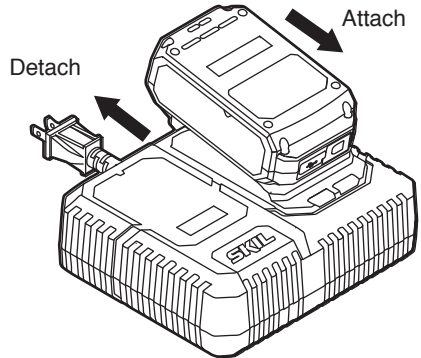

Charger Display (Fig. 3)

Fig. 3

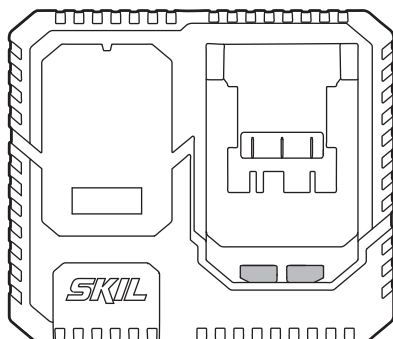

Mode	Charging Indicator (green)	Defect Indicator (red)	Note
Self-inspection completed	1 second	1 second	Shines for 1 second.
Self-inspection failed	Either or both are off		Either or both will normally have no reaction when the charger is plugged in.
Normal charging	Flashing	Off	The charger will automatically start charging the battery pack, if the battery pack temperature is within the charging temperature range.
Fully Charged	Steady green	Off	
Hot/Cold Battery	Off	Steady red	Remove the battery from the charger.
Defective	Off	Flashing or Off	Charging defect.

NOTICE: Charger may become warm with several continuous charge cycles. This is part of the normal operation of the charge. Charge in a well ventilated area.

Defective Charger

If the charger self-inspection fails to react when the charger is plugged in, the causes include no power to the charger, bad contacts, or a defective charger. Check to see if the charger self-inspection can be activated when the charger is plugged in again or plugged into a different outlet. If it still fails, have the charger serviced by an Authorized SKIL Service Station.

Defective Battery Pack

If the charger detects a problem, the red Defect Indicator will begin flashing. Remove and re-insert the battery pack in the charger. If the Defect Indicator flashes a second time, try charging a different battery pack.

- a) If a different battery pack charges normally, have the first defective battery pack serviced by an Authorized SKIL Service Station.
 - b) If a different battery pack also indicates “defective,” the charger may be defective. Have the charger serviced by an Authorized SKIL Service Station.
-

MAINTENANCE

Service

⚠ WARNING Preventive maintenance performed by unauthorized personnel may result in misplacing of internal wires and components which could cause serious hazard. We recommend that all tool service be performed by a SKIL Factory Service Center or Authorized SKIL Service Station.

General Maintenance

⚠ WARNING When servicing, use only identical replacement parts. Use of any other parts could create a hazard or cause product damage.

Periodically inspect the entire product for damaged, missing, or loose parts such as screws, nuts, bolts, caps, etc. Securely tighten all fasteners and caps and do not operate this product until all missing or damaged parts are replaced. Please contact customer service or an authorized service center for assistance.

⚠ WARNING To avoid serious personal injury, always remove the battery pack from the charger/tool when cleaning or performing any maintenance.

Cleaning

⚠ WARNING The tool may be cleaned most effectively with compressed dry air. **Always wear safety goggles when cleaning tools with compressed air.**

Ventilation openings and switch selectors must be kept clean and free of foreign matter. Do not attempt to clean by inserting pointed objects through openings.

⚠ WARNING Certain cleaning agents and solvents damage plastic parts. Some of these are: gasoline, carbon tetrachloride, chlorinated cleaning solvents, ammonia and household detergents that contain ammonia.

Storage

Store the tool indoors in a place that is inaccessible to children. Keep away from corrosive agents.

TROUBLESHOOTING

Problem	Cause	Remedy
Battery pack will not charge.	<ol style="list-style-type: none">1. Charger is not plugged into a functioning outlet.2. Battery pack is not properly inserted into the charger.3. Bad contacts.4. Battery is over- or under-temperature.5. Battery pack is damaged.6. Charger is damaged.	<ol style="list-style-type: none">1. Confirm that the charger is plugged into a functioning outlet.2. Confirm that the battery pack is inserted into the charger completely.3. Clean the contacts of the charger or battery packs.4. Cool the battery if too hot. Place the battery indoors if too cold.5. Have the battery pack serviced by an Authorized SKIL Service Station.6. Have the charger serviced by an Authorized SKIL Service Station.

LIMITED WARRANTY OF SKIL CONSUMER TOOLS

2 YEAR LIMITED WARRANTY- LEGAL

Chervon North America, Inc. ("Seller") warrants to the original purchaser only, that all SKIL consumer BATTERIES AND CHARGERS will be free from defects in material or workmanship for a period of two years from date of purchase.

Product registration can be completed online at www.Registermyskil.com. Original purchasers should also retain their receipt as proof of purchase.

Notwithstanding the foregoing, if a SKIL consumer portable power tool is used for industrial, professional or commercial purposes, the foregoing warranty will apply for a duration of ninety days, regardless of registration.

SELLER'S SOLE OBLIGATION AND YOUR EXCLUSIVE REMEDY under this Limited Warranty and, to the extent permitted by law, any warranty or condition implied by law, shall be the repair or replacement of parts, without charge, which are defective in material or workmanship and which have not been misused, carelessly handled, or repaired by persons other than Seller or Authorized Service Station. To make a claim under this Limited Warranty, you must return the complete product, transportation prepaid, to any SKIL Factory Service Center or Authorized Service Station. For Authorized SKIL Power Tool Service Stations, please visit www.Registermyskil.com or call 1-877-SKIL-999 (1-877-754-5999).

THIS LIMITED WARRANTY DOES NOT APPLY TO ACCESSORY ITEMS SUCH AS CIRCULAR SAW BLADES, DRILL BITS.

ANY IMPLIED WARRANTIES APPLICABLE TO A PRODUCT SHALL BE LIMITED IN DURATION EQUAL TO THE DURATION OF THE EXPRESS WARRANTIES APPLICABLE TO SUCH PRODUCT, AS SET FORTH IN THE FIRST PARAGRAPH ABOVE. SOME STATES IN THE U.S., SOME CANADIAN PROVINCES DO NOT ALLOW LIMITATIONS ON HOW LONG AN IMPLIED WARRANTY LASTS, SO THE ABOVE LIMITATION MAY NOT APPLY TO YOU.

IN NO EVENT SHALL SELLER BE LIABLE FOR ANY INCIDENTAL OR CONSEQUENTIAL DAMAGES (INCLUDING BUT NOT LIMITED TO LIABILITY FOR LOSS OF PROFITS) ARISING FROM THE SALE OR USE OF THIS PRODUCT. SOME STATES IN THE U.S. AND SOME CANADIAN PROVINCES DO NOT ALLOW THE EXCLUSION OR LIMITATION OF INCIDENTAL OR CONSEQUENTIAL DAMAGES, SO THE ABOVE LIMITATION OR EXCLUSION MAY NOT APPLY TO YOU.

THIS LIMITED WARRANTY GIVES YOU SPECIFIC LEGAL RIGHTS, AND YOU MAY ALSO HAVE OTHER RIGHTS WHICH VARY FROM STATE TO STATE IN THE U.S., PROVINCE TO PROVINCE IN CANADA AND FROM COUNTRY TO COUNTRY.

THIS LIMITED WARRANTY APPLIES ONLY TO PRODUCTS SOLD WITHIN THE UNITED STATES OF AMERICA, CANADA AND THE COMMONWEALTH OF PUERTO RICO. FOR WARRANTY COVERAGE WITHIN OTHER COUNTRIES, CONTACT YOUR LOCAL SKIL DEALER OR IMPORTER.

© Chervon North America, 1203 E. Warrenville Rd, Naperville, IL 60563.

02/19