

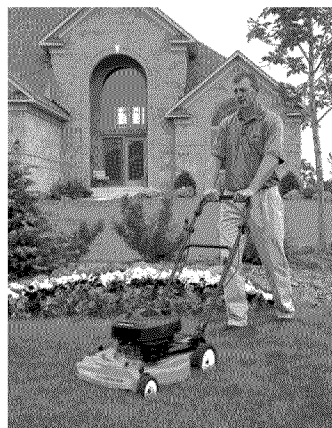

LAWN-BOY®

Quality of Cut

MANUAL

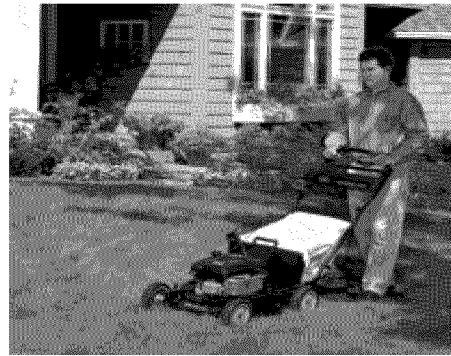

About This Manual

We hope that you find this manual a valuable addition to your service shop. If you have comments or questions about this manual contact your Distributor Service Manager or us directly at the following address:

**The Toro Company
Consumer Service Department
8111 Lyndale Avenue South
Bloomington, MN 55420-1196**

The Toro Company reserves the right to change product specifications or this manual without notice.

Table of Contents

Introduction

Manual Purpose	1-1
Intended Audience	1-1
Contents	1-1

Elements of Great Quality of Cut

Overview	2-1
Setup	2-1
Operator Instruction	2-2
Mower Preparation	2-2
Lawn Preparation	2-2
Safety	2-2
Mowing Tips	2-3

Inspecting and Sharpening the Blade

Overview	3-1
Removing the Blade	3-1
Inspecting the Blade	3-2
Sharpening the Blade	3-2
Balancing the Blade	3-2
Installing the Blade	3-3

Checking and Adjusting the Blade Level

Overview	4-1
Walk Behind Mower Overview	4-1
Riding Mower Overview	4-2
Checking Blade Level—All Mowers	4-2
Preparing the Workspace	4-2
Measuring Blade Level	4-3
Checking and Adjusting Blade Tracking	4-4
Walk Behind Mowers	4-4
Riding Mowers	4-4
Adjusting Blade Level	4-4
Walk Behind Mowers	4-4
Specifications and Tolerances	4-4
Adjusting Height of Cut	4-5
Models with Height of Cut Lever on Each Wheel	4-5
Mechanism Descriptions	4-5
Slipping Height of Cut Adjuster	4-5
Wheel Does Not Touch Ground	4-6



Table of Contents

Adjusting Side-to-Side Level	4-6
Adjusting Front-to-Rear Pitch	4-6
Models with Single Height of Cut Adjustment Lever	4-7
Wheel Does Not Touch Ground	4-7
Adjusting Side-to-Side Level	4-7
Adjusting Front-to-Rear Pitch	4-7
Riding Mowers	4-8
825 Rear Engine Rider	4-8
Adjusting Side-to-Side Level	4-8
Adjusting Front-to-Rear Pitch	4-8
Adjusting Blade Tracking	4-8
32-inch Rear Engine Rider	4-8
Adjusting Side-to-Side Level	4-9
Adjusting Front-to-Rear Pitch	4-9
Adjusting Blade Tracking	4-9
XL Series Front Engine Rider	4-9
Adjusting Side-to-Side Level—All Cutting Units	4-10
Adjusting Front-to-Rear Pitch	4-11
32-inch (81.3cm) Cutting Unit	4-11
38-inch (96.5cm) Cutting Unit	4-12
44-inch (111.7cm) Cutting Unit	4-13
Adjusting Blade Tracking	4-14
32-inch (81.3cm) Cutting Unit	4-14
38- and 44-inch (96.5 and 111.7cm) Cutting Units	4-15
260 Series Tractor	4-16
38-inch (96.5cm) Mower	4-16
Adjusting Side-to-Side Level	4-16
Adjusting Front-to-Rear Pitch	4-17
42-, 48-, 52-inch (106.6, 121.9, 132.0cm) Mowers	4-17
Adjusting Side-to-Side Level with Mower Suspended	4-18
Front-to-Rear Pitch	4-18
Blade Tracking—All 260 Series	4-18
300-400-500 Series Garden Tractor (Excluding 5xi Series)	4-19
Adjusting Side-to-Side Level	4-19
Adjusting Front-to-Rear Pitch	4-19
Adjusting Blade Tracking	4-20



Table of Contents

5xi Series Tractors	4-20
Adjusting Side-to-Side Level	4-20
44-, 48-, 52-inch (111.7, 121.9, 132.0cm) Mowers	4-20
60-inch (152.4cm) Mower	4-21
Adjusting Front-to-Rear Pitch	4-21
Adjusting Transport Blade Pitch	4-21
Adjusting Blade Tracking	4-22
TimeCutter Z	4-22
Adjusting Side-to-Side Level	4-22
Adjusting Front-to-Rear Pitch	4-23
Adjusting Blade Tracking	4-23
Troubleshooting Quality of Cut	
General Troubleshooting Procedures	5-1
Specific Quality of Cut Problems and Possible Solutions	5-1
Blowout	5-1
Clumping	5-1
Clogged Chute (Bagging or Side Discharging Only)	5-2
Dribbling	5-2
Ragged Cut	5-2
Scalping	5-2
Stair Step or Sawtooth Cut	5-2
Stragglers	5-2
Streaking	5-2
Uncut Grass	5-3
Windrow	5-3
Kits to Improve Quality of Cut	
Toro Recycler Mulch Plug	6-1
Washout Port Kit P/N 95-3282	6-1
Cast Deck Height of Cut Notch Repair Kits	6-1
Anti-scalping Roller Kit P/N 93-3898	6-2
Level Assist Kit P/N 94-9780	6-2
Level Assist Kit P/N 94-1592	6-2
Baffle Kits	6-2
Appendices	
Glossary	7-1
Special Tools	7-7
Mower Quality of Cut Checklist	7-8



This page intentionally left blank.

Manual Purpose

This manual describes the setup, operator instruction, and mowing tips that promote a great quality of cut. This manual contains material covering Toro and Lawn-Boy brand rotary mowers built in 2002. This information also applies to similarly-designed products produced before or after 2002. The Toro Company has made every effort to make the information in this manual complete and correct.

Intended Audience

This manual is written expressly for the Toro and Lawn-Boy servicing dealer. It assumes the reader has basic mechanical knowledge and skills.

Contents

This manual contains the following sections:

1. *Introduction* — This section.
2. *Elements of a Great Quality of Cut* — This section provides an overview of the setup and operator instruction that promote a great quality of cut.
3. *Inspecting and Sharpening the Blade* — This section describes how to remove, inspect, sharpen, balance, and install a blade.
4. *Checking and Adjusting Blade Level* — This section describes how to check and adjust the blade level on all types of Toro and Lawn-Boy brand rotary mowers built in 2002.
5. *Troubleshooting Quality of Cut* — This section describes general quality of cut troubleshooting procedures and procedures for addressing specific quality of cut problems.
6. *Kits to Improve Quality of Cut* — This section describes kits designed to address specific quality of cut problems on certain Toro and Lawn-Boy brand rotary mowers.
7. *Appendices* — This section contains a glossary of quality of cut terms and a list of special tools used in addressing quality of cut problems. It also contains a Mower Quality of Cut Checklist for use when troubleshooting quality of cut problems.

This page intentionally left blank.

Elements of Great Quality of Cut

Overview

Quality of cut issues are best handled before they happen. Two factors largely determine quality of cut: proper mower setup and adequate operator instruction. This section describes the elements of proper mower setup. It also describes the elements mower preparation, lawn preparation, safety procedures, and mowing tips the operator should know to use the mower safely to get a great quality of cut.



Figure 1

5300.012.TIF

We have found that an improperly set up mower can start the customer off with a feeling that their new mower is defective and will never be right. Once an operator gets the idea that the mower is defective, it can be very difficult and very time consuming to prove the machine is performing properly.

Customer education is the other part of the quality of cut formula. When a customer begins to use a new machine and it performs improperly, a complaint can be the result. When the machine is checked, sometimes no technical problems are found. This may indicate the customer is not operating the machine properly for the conditions.

It can be very difficult to convince a customer that a problem cannot be resolved in the shop, but must be resolved instead by a change in operating the mower. Initial customer education is critical in preventing this situation. If this situation arises after the customer has taken delivery of the mower, a visit to the customer's lawn for demonstration of the problem and the suggested solution may be necessary.



Figure 2

5300.010.TIF

Setup

On all mowers, proper mower setup consists of doing the following and making any necessary adjustments:

1. Inspect for damage, scratches, dents, and for bent or crooked parts. Make sure the wheels roll true and the control cables are undamaged. Repair any problems before continuing.
2. Fill engine with gas and oil (4 cycle) or fuel mix (2 cycle).
3. Check that all grease fittings are greased.
4. Check that all key hardware (blade bolt, wheels, handles, etc.) is tight.
5. Start the engine and check the no-load RPM.
Note: Engine speed typically increases 100–200 RPM during engine break-in. Set the engine RPM so that a small increase in no-load speed does not cause it to overspeed.
6. Operate the drive, blade, and traction controls (gear shift, throttle, choke, engine or blade-stop, etc.) to make sure they work properly.
7. Height of cut (HOC) adjusting mechanism moves freely and engages firmly.
8. Blade is sharp, balanced, and tracks properly.
9. Deck is level side-to-side and front-to-rear.

On riding mowers, also do the following and make any necessary adjustments:

10. Check the front wheel toe in.

Elements of Great Quality of Cut

11. Check the transmission fluid level. (See owner's manual; some models have a sealed transmission.)
12. Check the tire pressure, where applicable.

Note: Some models require installing the mower attachment. If the mower is factory-installed, check the blade pitch and deck level. These two factors are critical to a great quality of cut.

Operator Instruction

Even experienced operators should review the operation instructions for an unfamiliar machine. Every operator's manual contains safety and operation information the operator should review before operating the mower. Refer the operator to the operator's manual for details on operating the mower safely and effectively.

Mower Preparation

When reviewing mower operation procedures with an operator, do the following:

- Identify the location of the air filter and explain how to check it.
 - Describe how often the blade should be checked and sharpened. Explain that tipping a walk behind mower the wrong way to check the blade could cause gasoline to spill or oil to soak the air filter.
 - For a mower with a 4 cycle engine, explain how often the oil should be checked and what type of oil should be used. For a mower with a 2 cycle engine, explain the method for mixing fuel and oil properly. Remind the operator that the instructions for either of these procedures are in the operator's manual.
 - Identify the machine's safety features and explain how they work and how to use them. Remind the operator that safety instructions are in the operator's manual.
- Demonstrate for the operator the sound of the engine operating under a normal load and then operating in an overloaded condition in which it is starting to bog down.
 - Show the operator how to clean clippings out of the cutting chamber. Explain that this is important because clippings can harden and stick to the cutting chamber. Clippings adhering to the cutting deck change the airflow under the cutting deck and affect the quality of cut. They also generally bond to the deck paint and cannot be removed without also removing the paint.

Lawn Preparation

Explain to the operator that the operator's manual contains information for proper lawn preparation. Remind the operator of the following:

- The grass must be dry. Cut late in the day, after the sun has had a chance to dry the grass.
- Clear the area of objects such as rocks, toys, wire, bones, sticks etc., which could be picked up and thrown by the blade.

Safety

Explain to the operator that the operator's manual contains safety information about the mower, lawn preparation, operator dress and condition, and mowing procedures. When followed, this safety information contributes to a great quality of cut by ensuring that the operator and bystanders are safe, the mower operates properly, and the lawn is not damaged during mowing. The operator should be completely familiar with all aspects of operating the mower safely.

Mowing Tips

Explain to the operator that the operator's manual contains tips for getting a great quality of cut. Remind the operator of the following:

- The best ground speed is normal walking speed. However, if the engine bogs down at this speed, slow down to avoid degrading the lawn appearance.
- With a mulching mower, it may be necessary to mow more slowly than with a bagging or side discharge mower. Compared to bagging or side discharging, the time spent in mowing more slowly with a mulching mower is made up for by not emptying a bag or raking discharged clippings.
- The best height of cut varies with the type of grass and the season. In the spring and fall, when temperatures are moderate and rainfall is higher, height of cut can usually be decreased. In the summer, when the temperature increases and rainfall decreases, it is usually better to increase the height of cut.
- To maintain the health of the grass, turf grass agronomists recommend cutting no more than 1/3 of the grass height. Most rotary mowers designed for urban and suburban use work best when set up to cut no more than 1/3 of the grass height.
- When the height of cut is changed, the lawn takes a couple of weeks to adjust to the new cutting height. If the height of cut is increased, the grass may droop until it adjusts. If the height of cut is decreased, the lawn may temporarily look less green and lush.

This page intentionally left blank.

Inspecting and Sharpening the Blade

Overview

This section describes how to remove, inspect, sharpen, balance, and install a blade.

Blade condition is a key factor in quality of cut. The blade should always be straight and sharp. A sharp blade produces a clean, neat cut and helps ensure healthy grass plants. A dull blade tears and shreds grass, producing a poor quality of cut and damaging the grass plants.

Note: For best performance, install a new blade before the cutting season begins. During the year, file down any small nicks to maintain the cutting edge.

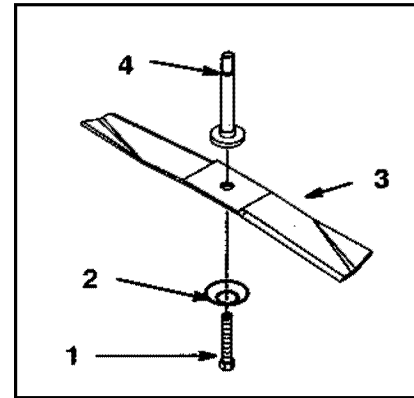

Figure 3

remove1.TIF

- | | |
|------------------|------------------|
| 1. Blade bolt | 3. Blade |
| 2. Curved washer | 4. Spindle shaft |

Removing the Blade

Note: On walk behind mowers, while the blade is attached to the mower, move the blade as little as possible to avoid future starting problems.

1. Stop the engine and wait for all moving parts to stop.
2. Disconnect the wire from the spark plug.
3. **Walk behind mowers:** Drain the fuel and oil from the engine. Tip the mower on its side, air filter up.

Riding mowers: Remove the mower attachment, or raise and block the tractor to allow access to the underside of the mower.

4. Loosen the blade fastener(s). The blade fasteners differ from mower to mower. Some mowers use a bolt and a lock washer; some use a bolt or a nut with a locking patch or locking material in the threads. Bolt size varies by mower model and size of blade. Always use the proper size wrench to remove the bolt or nut. An adjustable wrench can easily open and slip.
5. Grasp the end of the blade using a rag or a thickly padded glove. Remove the blade bolt (or nut) and the other component (Figure 3 and Figure 4).

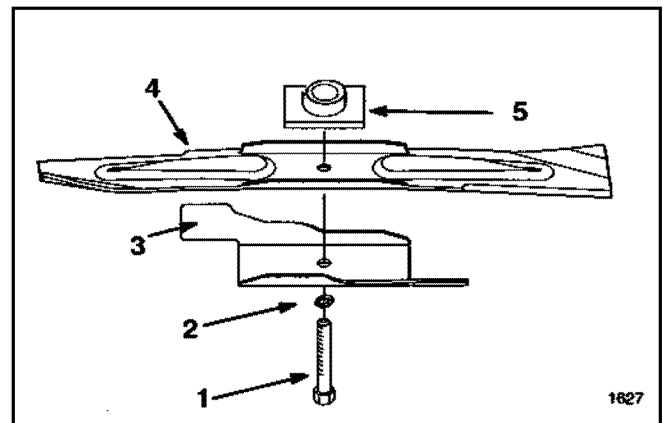

Figure 4

remove2.TIF

- | | |
|----------------|-----------------|
| 1. Blade bolt | 4. Blade |
| 2. Lock washer | 5. Blade driver |
| 3. Accelerator | |

Inspecting and Sharpening the Blade

Inspecting the Blade

Carefully examine the blade for sharpness and wear, especially where the flat and curved parts meet (Figure 5). The appearance of this part of the blade varies according to the model and type of blade.

Sand and other abrasive materials can wear away the metal that connects the flat and curved parts of the blade. Check the blade before using on the mower. If you notice a slot or wear, replace the blade.

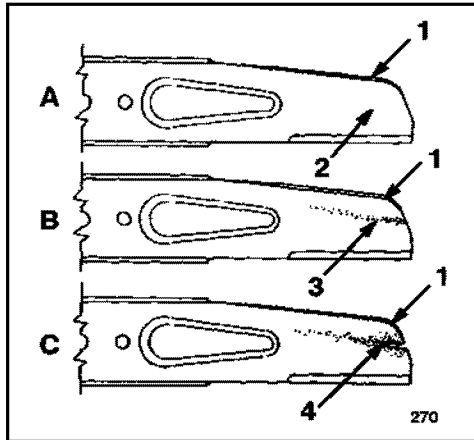

Figure 5 bladewear.TIF

- | | |
|------------------------------|-----------------------|
| 1. <i>Slot</i> | 3. <i>Wear</i> |
| 2. <i>Flat part of blade</i> | 4. <i>Slot formed</i> |

Sharpening the Blade

File or grind the top of the blade to maintain its original cutting angle and inner cutting edge radius. To keep the blade balanced, remove the same amount of material from both cutting edges (Figure 6).

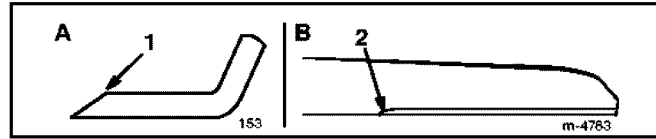

Figure 6 sharpen.TIF

1. *Sharpen at this angle only.*
2. *Maintain the original radius here.*

Balancing the Blade

1. Check the balance of the blade by placing the center hole of the blade over a nail or a screwdriver shank clamped horizontally in a vise (Figure 7).

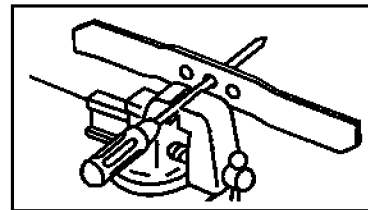

Figure 7 balance1.TIF

Note: You can also check the balance using a commercially-manufactured blade balancer such as the Magna-Matic MAG-1000 Professional Blade Balancer (Figure 8).

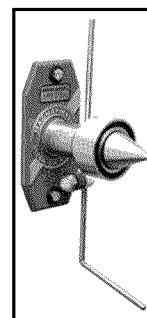

Figure 8 mag1000.jpg
Photo used with permission.

2. If either end of the blade rotates downward, file that end (not the cutting edge or the end near the cutting edge). The blade is properly balanced when neither end drops.

! Danger !

A worn or damaged blade can break, and a piece of the blade could be thrown into the operator's or bystander's area, resulting in serious personal injury or death.

- Inspect the blade periodically for wear or damage.
- Replace a worn or damaged blade.



Inspecting and Sharpening the Blade

Installing the Blade

1. Install the blade onto the spindle or blade driver. If the blade has curved tips (sails), they should be pointing towards the mower housing (Figure 9). If the bolt or nut uses a nylon patch or similar lock feature, it should be replaced every third time it has been removed. The patch will wear out with use. If a lock washer is used, inspect it for damage and replace if warranted.

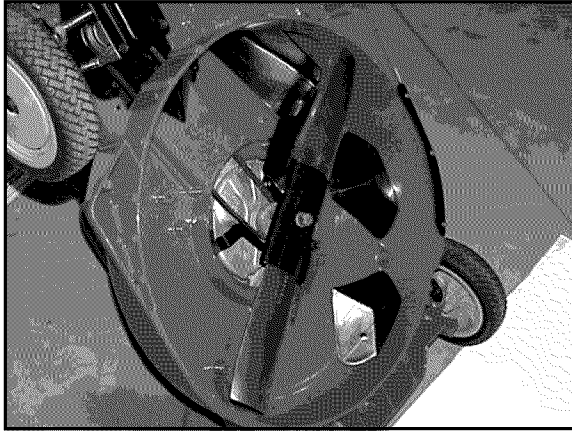

Figure 9

MVC-713X.jpg

2. Refer to the owner's manual for your particular unit for proper blade bolt/nut torque. Some common Toro, Toro Wheel Horse, and Lawn-Boy torque values are shown in the following table.

Blade Bolt (Nut) Torque Guide for Lawn-Boy, Toro, and Toro Wheel Horse Mowers built in 2002

Model	ft-lbs	Nm
Lawn-Boy 21-inch walk behind mowers	47	63
Toro 21-inch and 22-inch walk behind mowers with split washer on blade bolt	50	68
Toro 21-inch and 22-inch walk behind mowers with domed or flat washer on blade bolt	60	82
Toro Wheel Horse 25-inch, 32-inch, 38-inch, 44-inch mowers	45–60	61–81
Toro Wheel Horse 36-inch, 42-inch, 48-inch, 52-inch, 60-inch mowers	80–100	109–136

This page intentionally left blank.

Checking and Adjusting the Blade Level

Overview

This section describes how to check and adjust the blade level on consumer walk behind mowers and riding mowers. Four factors determine proper blade level:

- *Blade tracking—blade tips staying in a single plane of rotation as they turn*
- *Height of cut—height of blade above level surface*
- *Side-to-side level—each blade tip at the same height above a level surface when measured on either side of the mower*
- *Front-to-rear pitch—angle of blade when one tip points to the front of the mower and the other to the rear*

Some of the procedures for checking and adjusting blade level are common to all mowers. Some apply to walk behind mowers with a given type of height of cut system. Generally, each riding mower model has its own specific height of cut, side-to-side, and front-to-rear pitch adjustment procedures.

If you have a walk behind mower, see the following subsections for blade level adjustment procedures:

- *Walk Behind Mower Overview*
- *Checking Blade Level—All Mowers*
- *Checking and Adjusting Blade Tracking: Walk Behind Mowers*
- *Adjusting Blade Level: Walk Behind Mowers: Models with Height of Cut Lever on Each Wheel Models with Single Height of Cut Adjustment Lever*

If you have a riding mower, see the following subsections for blade level adjustment procedures:

- *Riding Mower Overview*
- *Checking Blade Level—All Mowers*
- *Adjusting Blade Level: Riding Mowers and subsections specific to adjusting your model*

Walk Behind Mower Overview

The method for checking and adjusting blade tracking is the same for all walk behind mowers. The method for checking and adjusting the height of cut, side-to-side level, and front-to-rear pitch depends on the height of cut system on the mower.

There are three height of cut systems used on consumer walk behind mowers. For checking and adjusting the height of cut, side-to-side level, and front-to-rear pitch on a given mower, see the subsection that discusses the height of cut system used on the mower.

Cast deck models (Toro Super Recycler and Lawn-Boy Gold Series) use notches cast into the mower housing (Figure 10) and spring arms and pins to engage those notches.

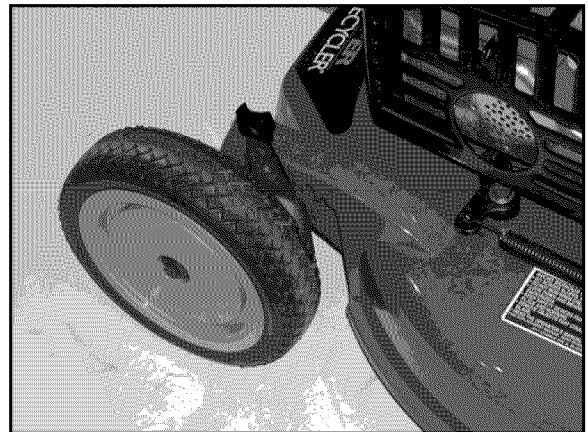

Figure 10

P2260001.JPG

Checking and Adjusting the Blade Level

Steel deck models (Toro Recyclers and Lawn-Boy Silver Series) use spring arms and pins to engage notches in a plate bolted to the mower housing (Figure 11).

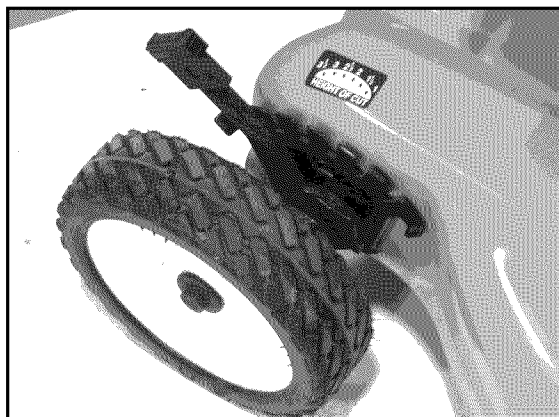

Figure 11 MVC-402X.jpg

Some models (43cm and 48cm models sold in Europe) use a single lever height of cut system (Figure 12).

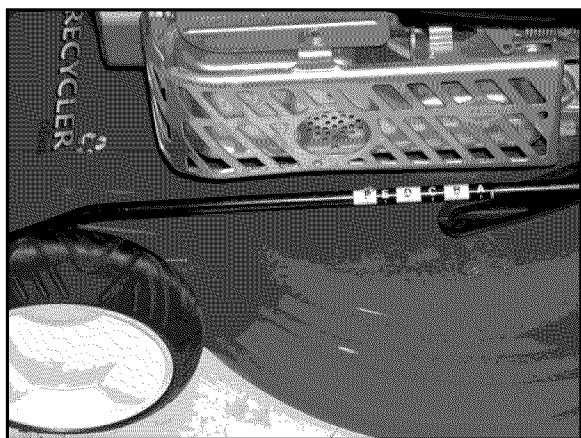

Figure 12 P2260003.JPG

Riding Mower Overview

Each series of riding mower has its own method of suspending the mower assembly. For checking and adjusting the blade tracking, height of cut, side-to-side level, and front-to-rear pitch on a given riding mower, see the subsection that discusses the appropriate series of riding mower.

Checking Blade Level— All Mowers

Checking the blade level involves preparing a suitable workspace and measuring the distance from one of the blade tips to a level flat surface at the 12, 3, 6, and 9 o'clock positions.

Preparing the Workspace

Use a straight edge to verify that the workspace is flat. Do not assume the floor is flat even if it appears to be so. You will make measurements with a tolerance of less than 3/16 inch (5mm) (Figure 13). A small dip in a concrete floor may cause you hours of work trying to find a problem that isn't there.

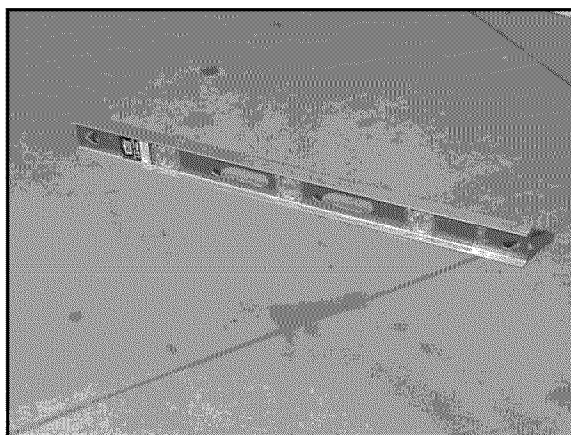

Figure 13 MVC-715X.JPG

For smaller product a 4 by 8 foot sheet of 3/4 inch plywood laid on the floor may assure you of a relatively flat surface. It is rigid enough to give you a good surface to measure from and will serve you for all mowers up to 48 inches wide and with a wheel base less than about 84 inches. For larger machines you may need to find a larger level area to verify the blades are at the correct level.

Checking and Adjusting the Blade Level

Measuring Blade Level

1. On products with inflatable tires, check the tire pressure. Tires are commonly over inflated for initial shipment. Make certain that the pressure has been lowered to the correct level for operation and that the tires are very close to the same (see the Operator's Manual). If the range is 10-15 psi, do not have some tires at 10 psi and others at 15 psi. Keep them near the same pressure.

Note: some products may have different recommended pressure for the front tires and the rear tires. Always check the Operator's Manual for the correct pressure.

2. Make a simple sketch of the mower housing to use for recording measurements. Show the outline of the mower and the blade(s). Leave a space to write in your measurements. Each blade must be measured at the 12, 3, 6, and 9 o'clock positions (Figure 14 and Figure 15).

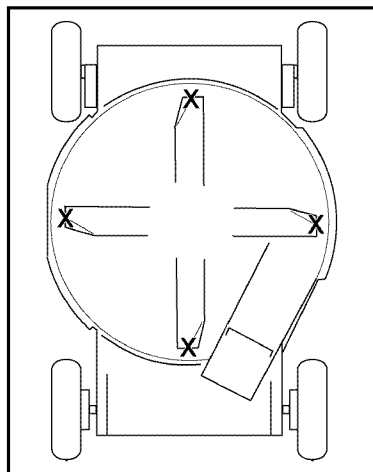

Figure 14

sketch1.TIF

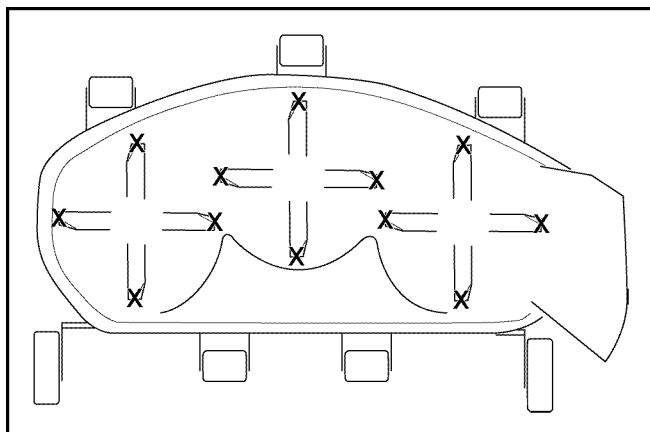

Figure 15

sketch2.TIF

3. If the desired height of cut is known, make your measurements at this setting. If this is not known set the mower in the middle of its height of cut (HOC) range.
4. **VERY IMPORTANT:** When you take the measurements, rotate the blade and use the SAME blade tip for measuring. Mark the blade with a piece of tape. It is not uncommon for there to be a slight difference between the two ends of the same blade. If you are working on a multiple blade mower, repeat the process with each blade.
5. If you are using the measuring tool (Figure 16), position the blade tip. Then place the tip of the tool under the tip of the blade and press the base of the tool on the floor. Read the measurement and note it on your sketch. Repeat in all 4 positions.

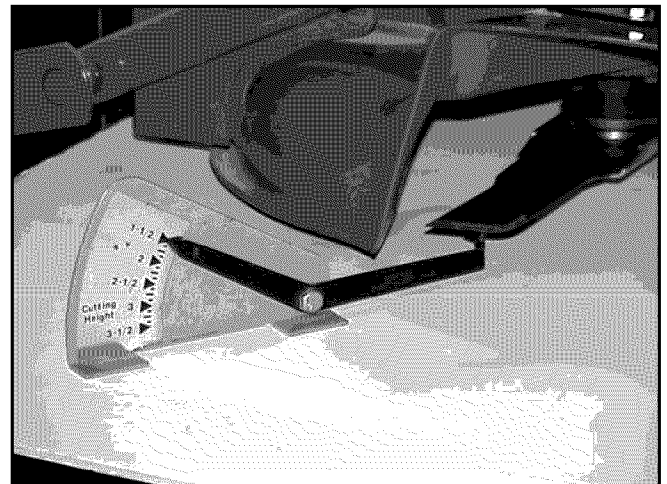

Figure 16

MVC-725X.JPG

Checking and Adjusting the Blade Level

If you don't have the measuring tool, use a piece of wood just short enough to fit under the mower housing. Wrap one end with tape. Place the untaped end on the floor and the tape against the cutting edge of the blade (Figure 17). Make a mark in the tape with the blade. Measure from the end that was on the floor to the mark you made in the tape and record the measurement on your sketch. Cover the marked tape with a fresh piece of tape. Repeat this process for each measurement, adding another layer of tape after each measurement so you have only one mark each time you measure.

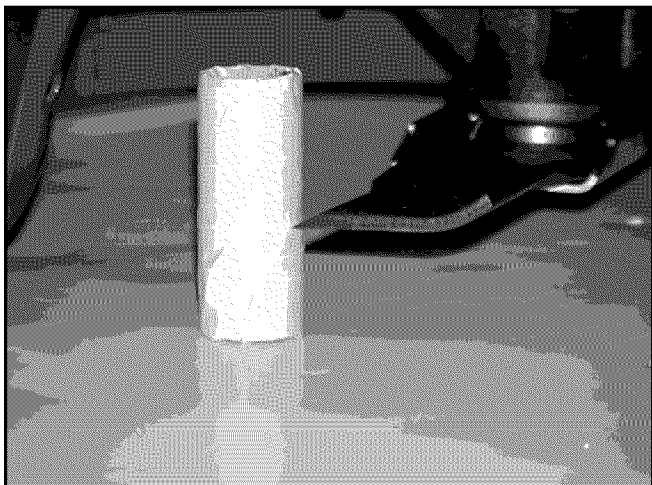

Figure 17 MVC-729X.JPG

- When the measurements are complete, proceed to the subsections in these instructions that cover the blade tracking and blade leveling procedures for the mower on which you are working.

Checking and Adjusting Blade Tracking

Walk Behind Mowers

Blade tracking can generally be checked visually. Use one blade tip turning it one rotation. It should stay close to the same level all the way around, a minimum of approximately 1/8 inch (3.1mm) above the bottom edge (Figure 18) of the mower housing. (Housings with cut-outs are more difficult to check. Verify all other measurements when checking these mowers.) If there is a large difference in the measurement from one area to another, the mower housing may be bent at the point where the engine or blade spindle mounts. You can correct for this by placing shim washers between the

engine or spindle and the housing. Check for level after installing shims.

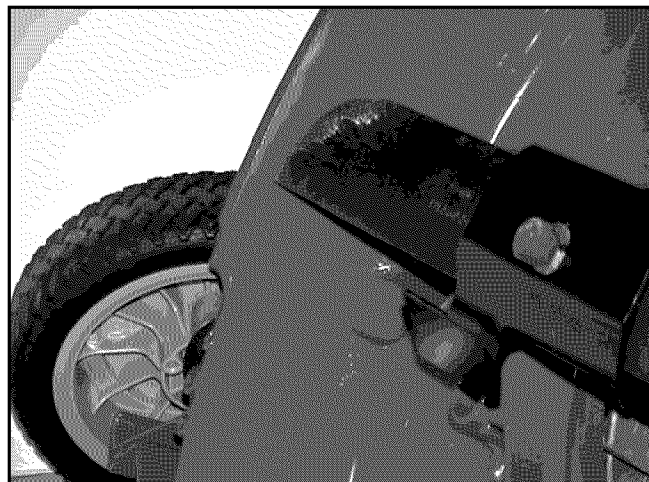

Figure 18 MVC-716X.JPG

Riding Mowers

For instructions on checking and adjusting the blade tracking on a riding mower, see the subsection in these instructions that covers the mower on which you are working.

Adjusting Blade Level

Walk Behind Mowers

Specifications and Tolerances

On walk behind mowers the blade should be level side-to-side within 1/8 inch (3.1mm).

The mower is designed with a 1-degree downward blade pitch when the tips of the blade are at the 12 o'clock and 6 o'clock positions from the operator's position. The difference between the measurement at the front and the rear will vary with the blade length. See the following table for common measurements.

Note: Tolerances in everything including wheels and pivot arms make the blade pitch specification approximate. Although the blade should not be level front to rear, it should not be tilted excessively. If the front-to-rear difference is within 1/8 inch (3.1mm) of the specification, the pitch is acceptable.

Checking and Adjusting the Blade Level

Blade Length/Nominal Front-to-Rear Pitch Measurement Difference

Blade Length: U.S. Models	Front-to-Rear Pitch Measurement Difference
18 inches	0.314 inch
21 inches	0.366 inch
22 inches	0.383 inch
Blade Length: Metric Models	Front-to-Rear Pitch Measurement Difference
40cm	6.89mm
43cm	7.45mm
46cm	7.62mm
48cm	8.35mm
51cm	8.99mm
53cm	9.29mm

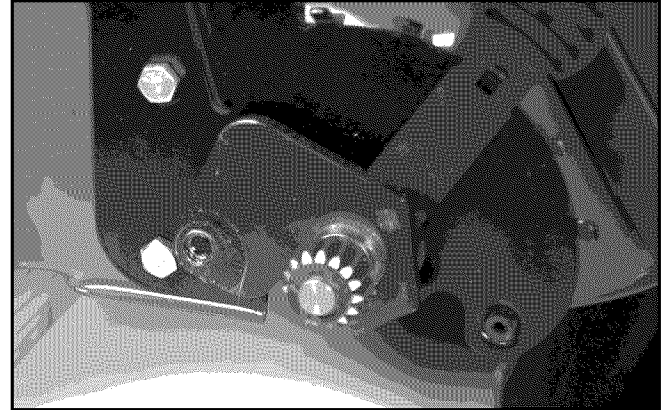

Figure 20

2768-0011.TIF

Adjusting Height of Cut

While measurement procedures are the same for all walk behind mowers, the type of suspension or height of cut adjusters on a given mower determine the procedures to use in adjusting the height of cut.

Models with Height of Cut Lever on Each Wheel

Mechanism Descriptions

Toro and Lawn-Boy have similar systems for individual wheel adjusters. A spring arm with a pin to engage a notch is used to determine the height of cut on these models. On cast deck models this notch is molded in the deck (Figure 19). On steel decks a steel height of cut plate serves this purpose (Figure 20).



Figure 19

0185-12.TIF

Slipping Height of Cut Adjuster

If the spring arm will not maintain height of cut, it has lost spring tension and must be replaced. When the height of cut spring arm is weak and has slipped a number of times, it can wear away the notches. On steel decks the height of cut plate should be replaced if this happens. On cast decks, this wear is in the deck housing itself. One alternative is to replace the deck housing. However, there are two wear plate kits, which fit many 21-inch Toro models:

Kit PN 105-1290 fits Toro 21-inch Super Recyclers manufactured 1995 and newer (Figure 21).

Kit PN 49-4080 fits the older 21-inch Recyclers and Rear Baggers (Figure 22).

Note: These kits do not fit any Vacu-Power, Commercial (Pro Line), or Landscaper models.



Figure 21

mvc-460.tif

Checking and Adjusting the Blade Level

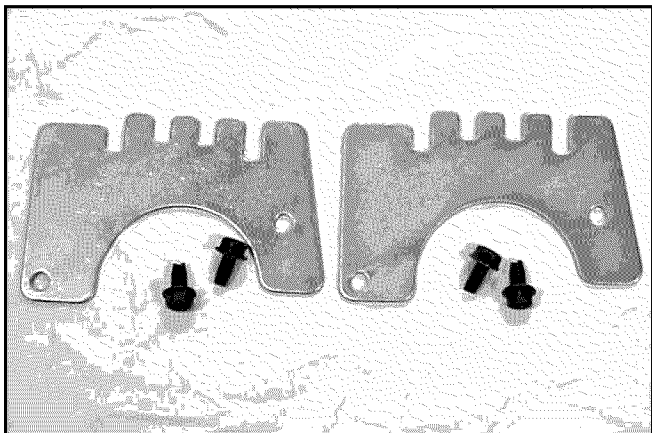

Figure 22 2001-065.TIF

Wheel Does Not Touch Ground

If one of the wheels does not touch the ground on a level surface, verify that all four spring arms are in the same notch and that those notches are not worn. Make any necessary adjustments (for correcting worn notches, see "Slipping Height of Cut Adjuster" on page 4-5).

If the spring arms are in the same notch and the notches are not worn, and the wheel that does not touch the ground is 1/8 inch (3.1mm) or less above the ground, you can correct the problem by lowering one of the front wheels. Remove the front wheel that is on the ground and its pivot arm. Use a round file to elongate the pivot bolt holes upward (Figure 23).

Caution

The aluminum alloy on cast decks files away quickly. Be careful not to elongate the pivot bolt hole excessively.

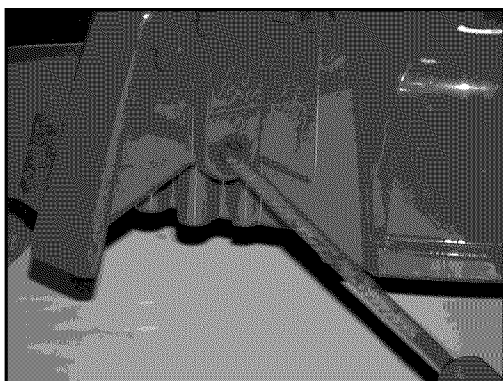

Figure 23 MVC-718X.JPG

Reinstall the pivot and wheel. When you reinstall the wheel, use the extra clearance to raise it to the position of the other front wheel. After reinstalling the wheel and pivot, verify that the blade is level side-to-side.

Adjusting Side-to-Side Level

If the blade is not level within 1/8 inch (3.1mm) side to side, the engine will need to be shimmed. Loosen the engine mounting screws on the low side of the blade. Slip a washer or other shim material between the engine and housing (Figure 24). On a 21-inch mower, use a shim about half as thick as the distance to be shimmed. For instance, if the blade is off 1/8 inch (3.1mm), use a 1/16 inch (1.5mm) shim. Re-measure the blade. If the blade is within 1/8 inch of being level from side to side, remove the engine mounting screw and reinstall it through the housing, shim, and engine.

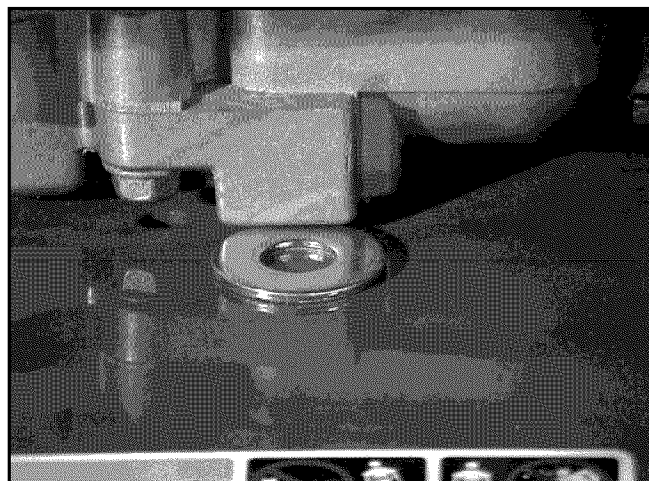

Figure 24 MVC-720X.JPG

Adjusting Front-to-Rear Pitch

Correction of front-to-rear pitch on a walk behind mower is rarely necessary. If the blade pitch is significantly out of specification, it is best to replace the mower housing.

Checking and Adjusting the Blade Level

Models with Single Height of Cut Adjustment Lever

A typical model with a single height of cut adjustment lever is shown below (Figure 25).



Figure 25

2001-046.TIF

Wheel Does Not Touch Ground

This may indicate that either the front or rear axle is bent. This can be resolved by identifying and replacing the bent axle.

An alternate fix would be to shim the affected axle. Turn the machine over. The front axle is attached to the mower with a bracket on each side. In this case, go to the side where the front wheel does not touch the ground. Remove the cap screws that secure the bracket to the mower housing. Insert the shim between the cap and housing and install the cap screws (Figure 26).

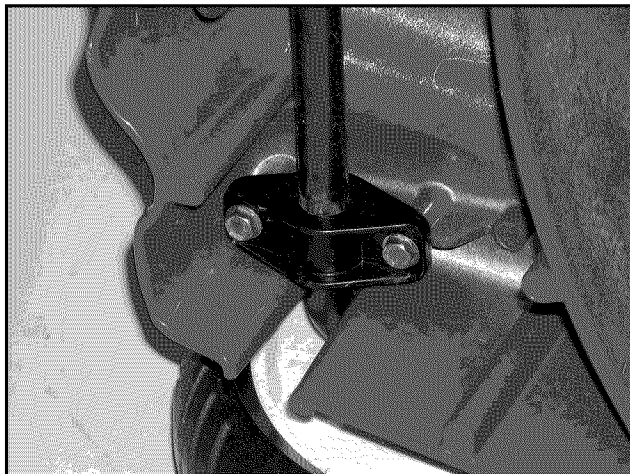

Figure 26

p2260004.JPG

Adjusting Side-to-Side Level

Loosen the engine mounting screws on the side where the blade is low (Figure 27). Temporarily insert a washer between the engine and mower housing and re-measure the blade. If it is now level, remove the engine mounting screw and re-install through the housing, washer, and engine. Check the level after the bolts are tight.

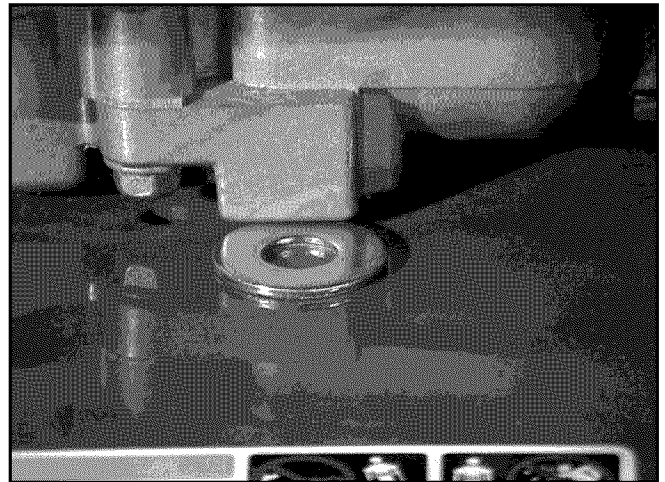

Figure 27

MVC-720X.JPG

Adjusting Front-to-Rear Pitch

Changes in front-to-rear pitch occur only if the front-to-rear link is bent (Figure 28) or the connections on the ends are worn. If the connections at the ends of the link are worn, replace them. If the pitch is still dramatically out of specification, the front-to-rear link or one of the axles is bent. Replace the damaged parts.

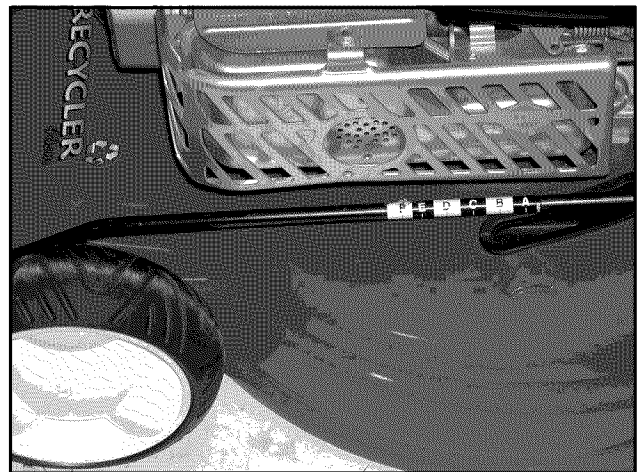

Figure 28

mvc-408x.jpg

Checking and Adjusting the Blade Level

Riding Mowers

Each series of riding mower uses different cutting units with unique suspension systems. Because of that, look for the type of riding mower you have and read the section that applies. **IMPORTANT:** perform all the steps under “Checking Blade Level—All Mowers” before beginning to measure.

825 Rear Engine Rider

The 825 Rear Engine Rider has no provision for normal adjustment of side-to-side level or front-to-rear pitch (Figure 29).

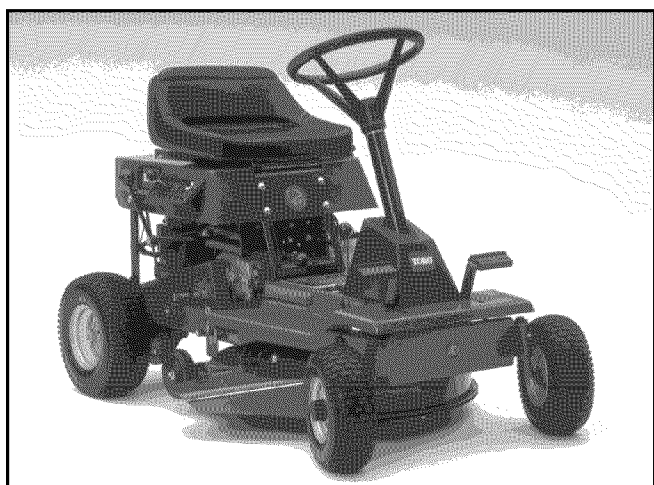

Figure 29

1222-01.TIF

Adjusting Side-to-Side Level

If the mower is more than 1/8 inch (3.1mm) off side to side, correction is recommended. Since this is not a normal adjustment, there is a possibility the deck suspension is badly worn or bent. Replace the parts as necessary.

Adjusting Front-to-Rear Pitch

The blade should be 7/16 inch (10.9mm) lower when it passes the front of the mower than when it passes the rear. This measurement can be between 1/8 inch (3.1mm) and 1/2 inch (12.7mm) low in front. If the difference is out of this range, the mower suspension is either worn or bent. Straighten or replace as needed.

Adjusting Blade Tracking

The blade should be a minimum of 1/8 inch (3.1mm) above the bottom of the housing. If out of tolerance, insert a washer or other shim between the spindle housing and mower housing (Figure 30). Re-measure the blade side to side. If now correct, remove the spindle housing bolt and re-install through the housing, shim, and spindle. Note that the blade tip will move more than the thickness of the shim.

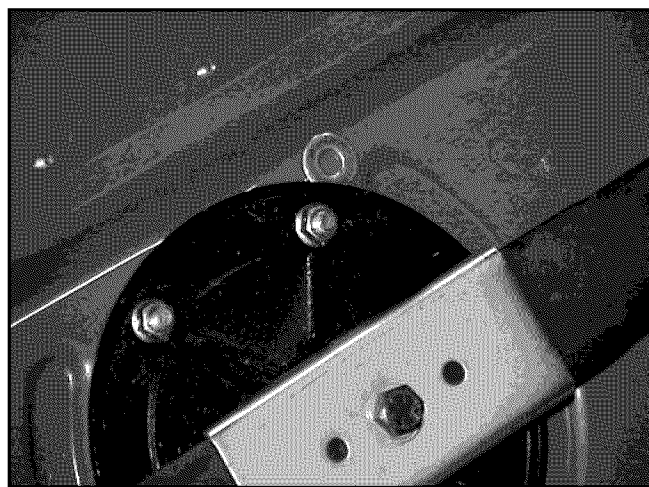

Figure 30

MVC-732X.JPG

32-inch Rear Engine Rider

The 32-inch Rear Engine Rider has been built with various engines. However, all use the same mower attachment and suspension (Figure 31).

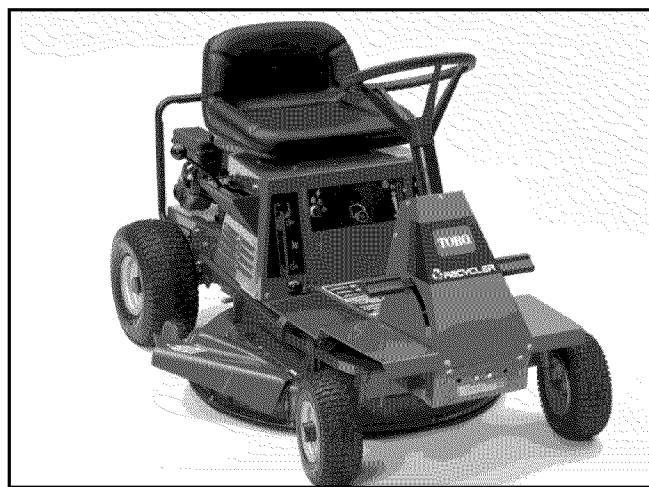

Figure 31

1222-05.TIF

Checking and Adjusting the Blade Level

Adjusting Side-to-Side Level

The blade should be level within 3/16 inch (5.0mm). The height of cut bracket on the left side of the chassis can be adjusted up and down to level the blade. Loosen the two cap screws holding the bracket to the frame rail to do this (Figure 32).

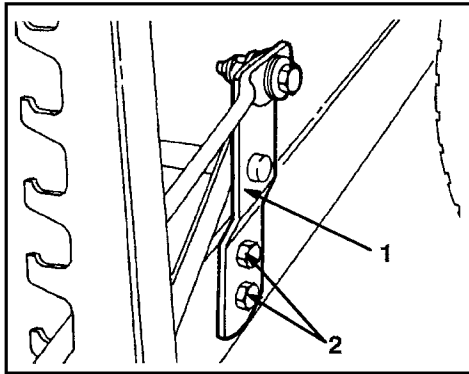

Figure 32

32rerS2S.TIF

1. Height of cut support bracket
2. Capscrews

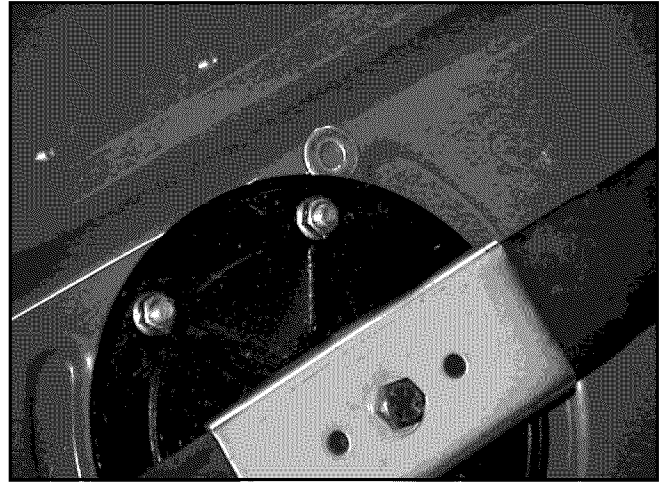

Figure 33

MVC-732X.JPG

Adjusting Front-to-Rear Pitch

The blade should be 1/4-5/8 inch (6-16mm) lower at the front of the mower than at the rear. This measurement can be between 1/8 inch (3.1mm) and 5/8 inch (15.7mm) low in front. If the difference is out of this range, the mower suspension is either worn or bent. Straighten or replace as needed.

Adjusting Blade Tracking

The blade should be a minimum of 1/8 inch (3.1mm) above the bottom of the housing. If out of tolerance, insert a washer or other shim between the spindle housing and mower housing (Figure 33). Re-measure the blade side to side. If now correct, remove the spindle housing bolt and re-install through the housing, shim, and spindle. Note that the blade tip will move more than the thickness of the shim.

XL Series Front Engine Rider

The XL Series Front Engine Rider has been offered with three cutting units. A 32-inch (81.3cm) single blade, a 38-inch (96.5cm) twin blade, and a 44-inch (111.7cm) three blade mowing deck (Figure 34). Side-to-side adjustment procedures are the same for all three mowing decks. However, the front-to-rear pitch varies between the three.

On the cutting units with multiple blades, the blades must line up with each other in the same cutting plane. This is considered part of blade tracking and is covered under that heading.



Figure 34

4017-02.TIF

Checking and Adjusting the Blade Level

Adjusting Side-to-Side Level—All Cutting Units

Measure from the blade tip to the ground on each side. On single blade mowers use the same blade tip for both measurements (Figure 35). On multiple blade models, choose a tip on each blade and mark it so you can refer back to the same one (Figure 36 and Figure 37).

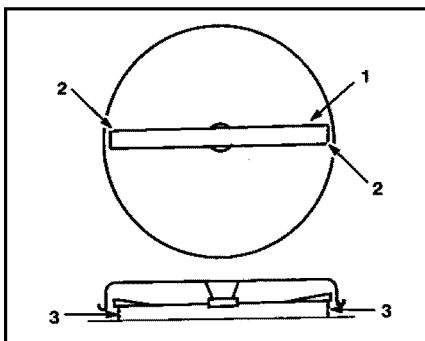

Figure 35 XL1bS2S.TIF

1. Blade side to side
2. Outside cutting edges
3. Measure here

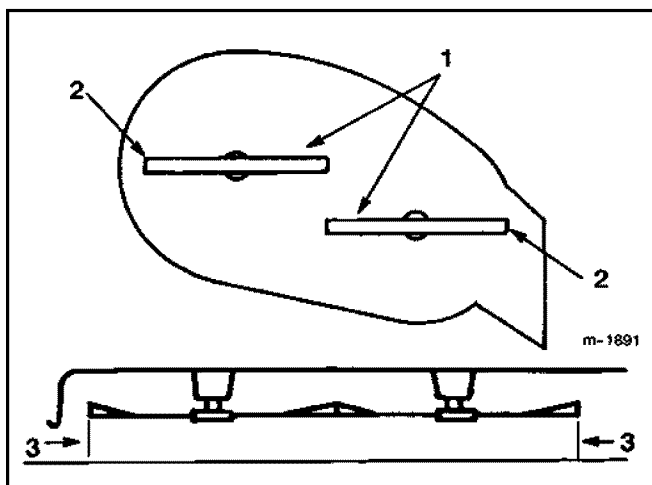

Figure 36 XL2bS2S.TIF

1. Blade side to side
2. Outside cutting edges
3. Measure here

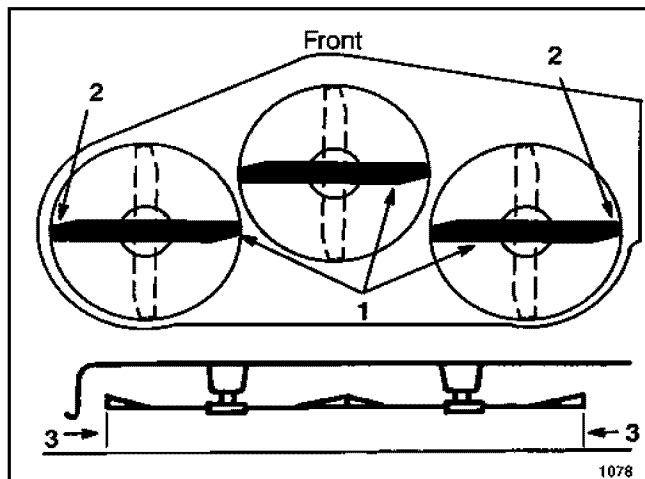

Figure 37 XL3bS2S.TIF

1. Blade side to side
2. Outside cutting edges
3. Measure here

If there is more than a 3/16 inch (4.5mm) difference side to side, adjustment is necessary. Remove the hairpin cotter and washer from the leveling bracket (Figure 38). To level the blade(s), reposition the leveling bracket(s) in a different hole and install the washer and hairpin cotter. Moving to a hole nearer the front lowers the blade height. Moving to a hole nearer to the rear raises the height. There are identical brackets on both sides. Use the holes in both to level the blades side to side. The brackets do not need to be in the same hole on both sides.

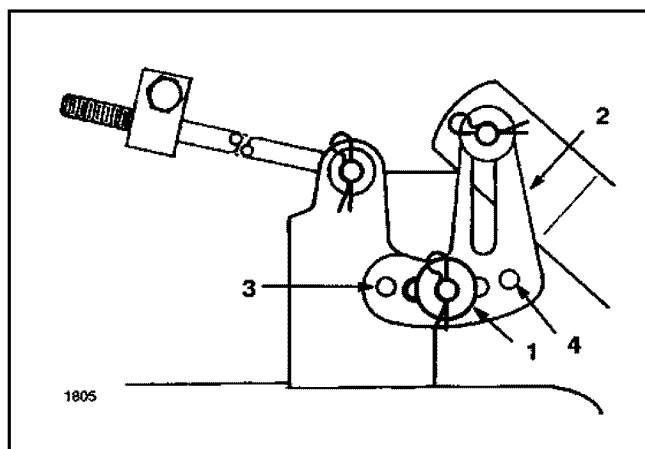

Figure 38 XL4bkt.TIF

1. Hairpin cotter and washer
2. Leveling bracket
3. Front hole
4. Rear hole

Checking and Adjusting the Blade Level

Adjusting Front-to-Rear Pitch

Each of the three XL cutting units has a slightly different specification for front-to-rear pitch and slight variations in the adjustment process. Each cutting unit is covered separately in one of the following subsections.

32-inch (81.3cm) Cutting Unit

The blade on this model should be 1/4-5/8 inch (6-16mm) lower in front. If the pitch is outside this range adjustment is necessary (Figure 39).

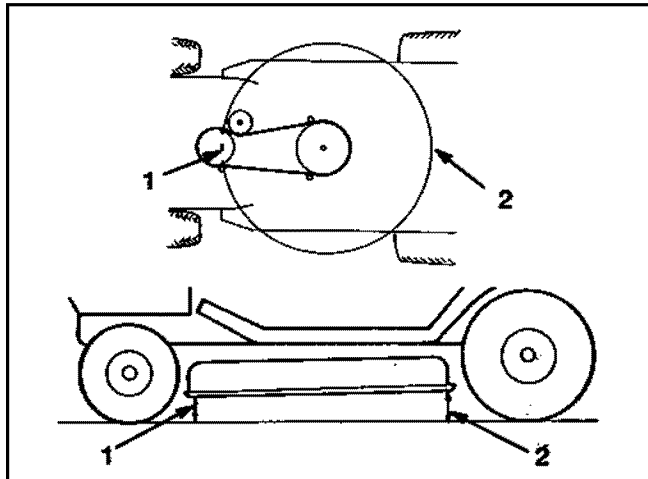

Figure 39 XL32pit1.TIF

1. Measure front center 2. Measure rear center

1. Verify that the side-to-side level is correct. If not adjust that first.
2. Measure the length of the rod extending out of the front of the adjusting block on the sides of the chassis (Figure 40). If the rod length is not 5/8 inch (16mm), remove the hairpin cotter and washer from the end of the rod and turn the rod until the 5/8 inch (16mm) dimension is obtained. Then install the end of the rod into the hole in the mower mount and secure it in place with the washer and hairpin cotter. Repeat this process on the other side of the mower.

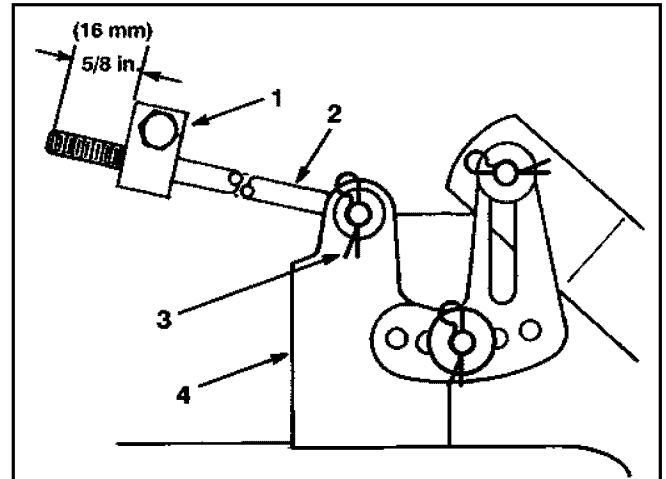

Figure 40 XL32pit2.TIF

1. Adjusting block 3. Hairpin cotter and washer
2. Long rod 4. Mower mount

3. Check the front-to-rear pitch again. If the front is still out of specification proceed to step 4. Otherwise, recheck the side-to-side level to ensure it did not change.
4. Adjust the front-to-rear pitch by rotating the special pitch adjusting nuts on both sides of the mower pivot mount (Figure 41).

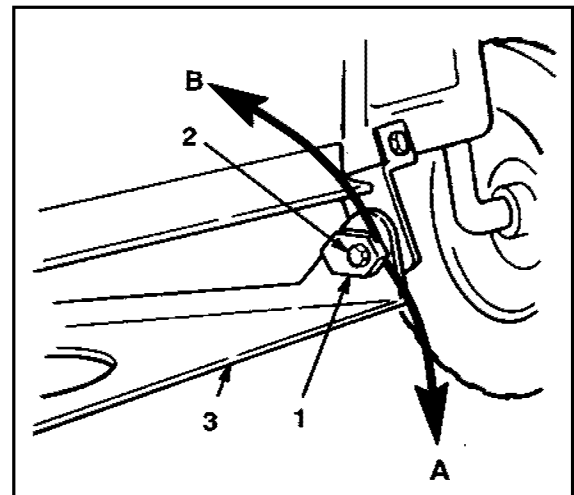

Figure 41 XL32pit3.TIF

1. Pitch adjusting nut (left) 2. Bolt and locknut
A = Down to raise mower 3. Mower pivot mount
B = Up to lower mower

Checking and Adjusting the Blade Level

5. Using a 1-inch wrench or socket, slowly rotate the left side adjusting nut down to raise the front of the mower and up to lower it.

6. Slowly rotate the right side adjusting nut until both nuts are in the same position.

Note: If the adjusting nut does not stay in position, tighten the center bolt and locknut and repeat steps 4 and 5.

7. If the 1/4 to 5/8 inch (6-16mm) pitch cannot be achieved by rotating the adjusting nuts, move the mower pivot mount at the front of the mower housing (Figure 42).

Note: Some models only have one pair of holes to select from. If the model you are working on only has one hole and the front-to-rear pitch is still out of specification, go back to the basics. Check the tire pressure and inspect for a worn or damaged chassis or suspension component.

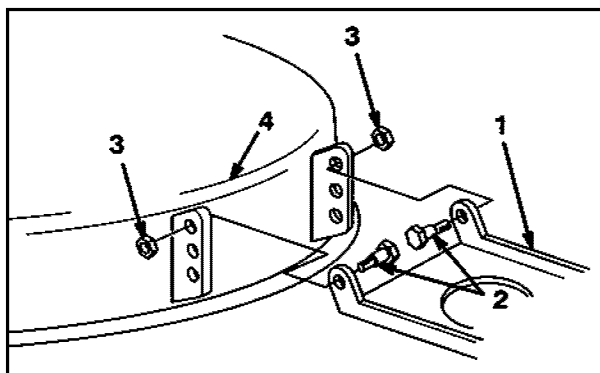

Figure 42

XL32pit4.TIF

- | | |
|------------------|------------|
| 1. Mower pivot | 3. Locknut |
| 2. Shoulder bolt | 4. Mower |

8. Remove the shoulder bolts and lock nuts from the mower. Installing the bolts in a higher hole will lower the blade and using a lower hole will raise it.

9. Repeat the front-to-rear adjustment steps 3-7.

10. Once the front-to-rear pitch is within specification, recheck the side-to-side adjustment (see "Adjusting Side-to-Side Level—All Cutting Units" on page 4-10).

11. Once the front-to-rear pitch and side-to-side level are within specification, continue by checking and adjusting the blade tracking (see "Adjusting Blade Tracking" on page 4-14).

38-inch (96.5cm) Cutting Unit

The blade pitch for a 38-inch (96.5cm) mower is correct when the blade in front is 1/8-3/8 inch (3.5-10.5mm) lower in front than in the rear. If adjustment is necessary proceed as follows.

1. Verify that the mower is level side to side. If not adjust that first.

2. Measure the length of the rod extending out the front of the adjusting block on the sides of the chassis (Figure 43). If the rod length is not 5/8 inch (16mm), remove the hairpin cotter and washer from the end of the rod and turn the rod until the 5/8 inch (16mm) dimension is obtained. Then install the end of the rod into the hole in the mower mount and secure it in place with the washer and hairpin cotter. Repeat this procedure on the other side.

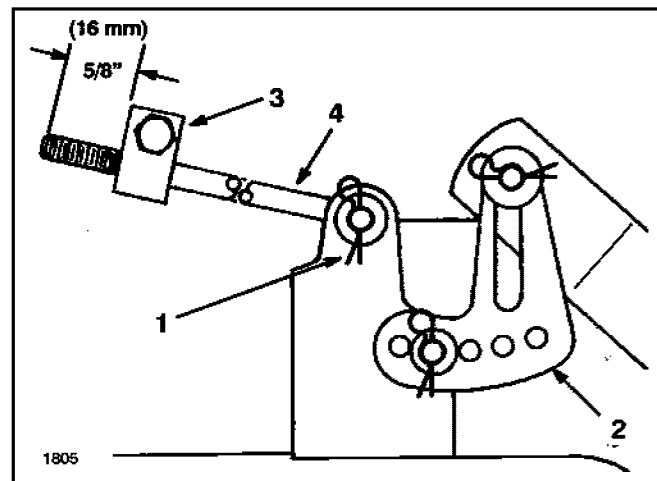

Figure 43

XL38pit1.TIF

- | | |
|------------------------------|---------------------|
| 1. Hairpin cotter and washer | 3. Adjustment block |
| 2. Leveling bracket | 4. Long rod |

3. Recheck the front-to-rear pitch. If it is not within specification, proceed to step 4.

Checking and Adjusting the Blade Level

- To adjust the front-to-rear pitch, loosen the front pivot plate mounting bolts slightly (Figure 44).

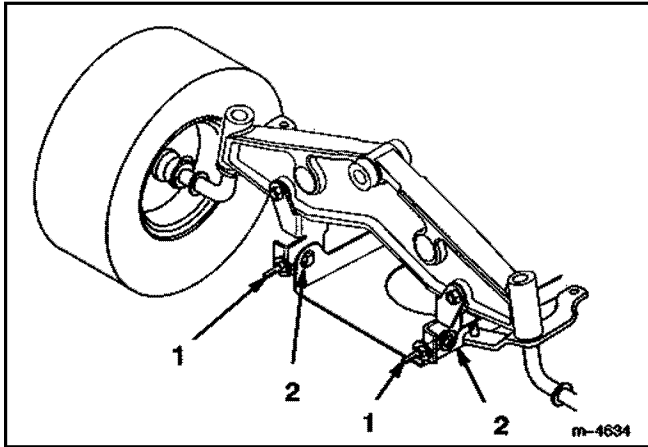

Figure 44 XL38pit2.TIF

- Eye bolt locknut
- Pivot mounting bolt

- Rotate lock nuts on eyebolts to change the adjustment. To raise the front of the mower, tighten the eyebolt lock nuts. To lower the front of the mower, loosen the eyebolt lock nuts.
- After adjusting both eyebolt lock nuts evenly, check the front-to-rear pitch again. Continue adjusting until the blade pitch is within specification.
- Tighten the pivot plate mounting bolts.
- Recheck the side-to-side level and correct if necessary (see "Adjusting Side-to-Side Level—All Cutting Units" on page 4-10).
- Once the front-to-rear pitch and side-to-side level are within specification, continue by checking and adjusting the blade tracking (see "Adjusting Blade Tracking" on page 4-14).

44-inch (111.7cm) Cutting Unit

- Check side-to-side level and adjust as needed (see "Adjusting Side-to-Side Level—All Cutting Units" on page 4-10).
- Measure the length of the rod extending out the front of the adjusting block on the sides of the chassis (Figure 45). If the rod length is not 5/8 inch (15.875mm), remove the hairpin cotter and washer from the end of the rod and turn the rod until the 5/8 inch (15.875mm) dimension is obtained. Then install the end of the rod into the hole in the mower mount and secure in place with the washer and hairpin cotter. Repeat this procedure on the opposite side of the mower.

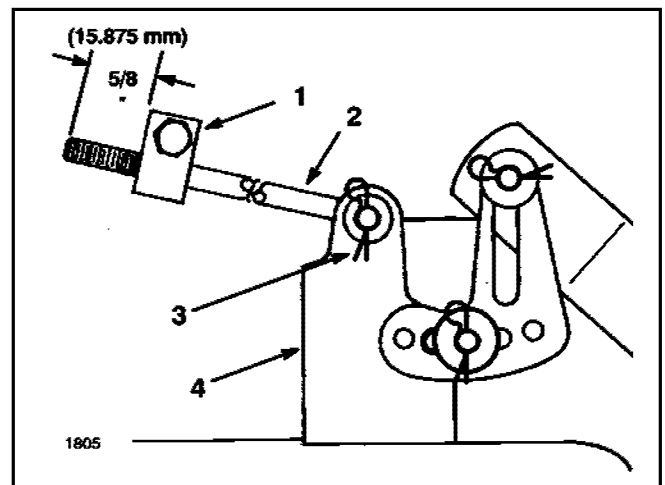

Figure 45 XL44pit1.TIF

- Adjusting block
- Adjusting rod
- Hairpin cotter and washer
- Mower mount

- Move the height of cut lever (deck lift) into the "C" notch and rotate the blades so they are facing front to rear.

Checking and Adjusting the Blade Level

4. Measure from the front blade tip to the ground, mark that tip with tape for future reference and rotate it 180 degrees to the rear and measure from the tip to the ground. If the tip in the front is not 0-5/16 inch (0-8mm) lower than in the rear, adjustment is necessary (Figure 46).

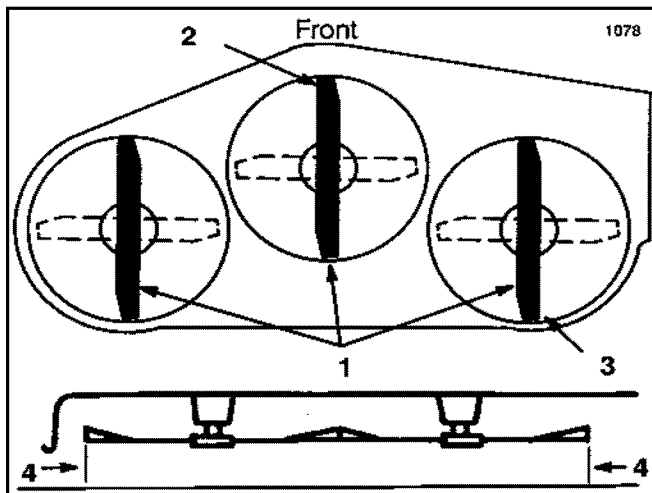

Figure 46

XL44pit2.TIF

1. Blade front to rear
2. Measure front blade tip
3. Measure rear blade tip
4. Measure here tip

5. To adjust the front-to-rear pitch, loosen the front mounting plate bolts slightly (Figure 47).

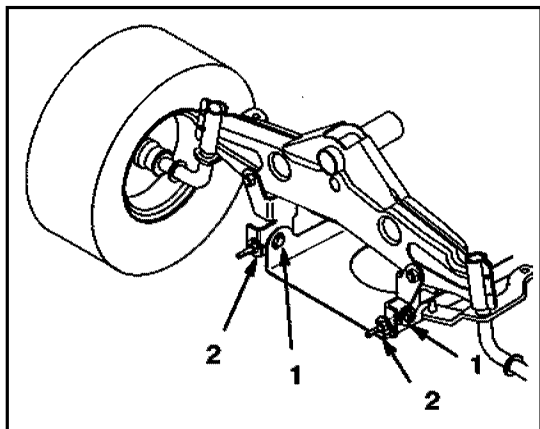

Figure 47

XL44pit3.TIF

1. Pivot mounting bolt
2. Eyebolt locknut

6. Rotate the lock nuts on the eyebolts to change the adjustment. To raise the front of the mower, tighten the eyebolt lock nuts. To lower the front of the mower, loosen the eyebolt lock nuts.

7. After adjusting both eyebolt lock nuts evenly, check the front-to-rear pitch again. Continue adjusting the eyebolts until the front blade tip is 0-5/16 inch (0-8mm) lower than in the rear.
8. When the front-to-rear pitch is correct, tighten the pivot plate mounting bolts.
9. Check the side-to-side level to assure that has not changed. Correct if needed (see "Adjusting Side-to-Side Level—All Cutting Units" on page 4-10).
10. Check gage wheel height. Each wheel should be approximately 3/8 inch (9.5mm) off the ground. Adjust as needed.
11. Once the front-to-rear pitch and side-to-side level are within specification, continue by checking and adjusting the blade tracking, as follows.

Adjusting Blade Tracking

The 32-inch (81.3cm) cutting unit requires a blade tracking adjustment procedure different from the procedure required for the 38-inch (96.5cm) and the 44-inch (111.7cm) cutting units. Use the procedure, as follows, appropriate to the cutting unit on which you are working.

32-inch (81.3cm) Cutting Unit

The blade should be a minimum of 1/8 inch (3.1mm) above the bottom of the housing. If it is not, you may adjust it by inserting a washer or other shim between the spindle housing and mower housing. Re-measure the blade side to side. If now correct, remove the spindle-housing bolt and re-install through the housing, shim, and spindle. Note that the blade tip will move more than the thickness of the shim. This adjustment is to ensure the blade travels in an even plane at an even distance above the bottom of the mower housing.

Checking and Adjusting the Blade Level

38- and 44-inch (96.5 and 111.7cm) Cutting Units

On mowers with multiple blades, not only do the blades need to be a minimum of 1/8 inch up from the bottom edge of the housing, but they must also line up where the tips come together. Take the two blade tips and point them towards each other. They must be within 1/8-3/16 inch of level with each other, or both must be the same distance from the blade to the ground (Figure 48).

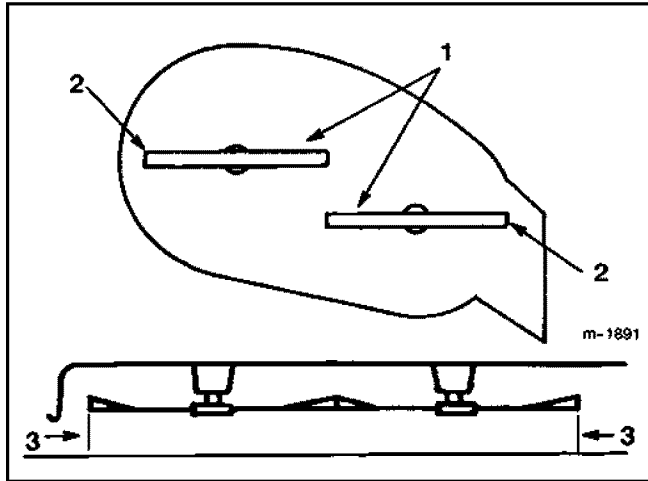

Figure 48

XL2bS2S.TIF

1. Blade side to side
2. Outside cutting edges
3. Measure here

An alternate way to check this is to remove the mower housing and turn it over. Remove both blades and lay a straight edge on both blade saddles (Figure 49). It should lie flat. If not, either the spindle or the housing where the spindle mounts may be bent.

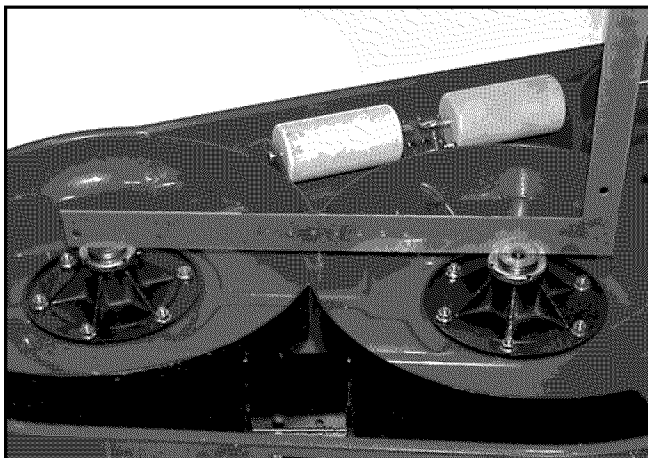

Figure 49

albttrk.TIF

To check for a bent spindle, remove the belt and spin the blade spindle. Look at the center; if it rotates in a tight circle, the spindle is not bent. If the center appears to wobble, the spindle is bent and should be replaced.

Yet another way to check this with the blades attached is to align the blades (two blades at a time on three blade mowers), then run a string across the cutting tips of the blades. The string should be straight. If it is not, the blade or spindle could be bent.

If the saddles or blades do not line up and the spindles are not bent, a shim between the spindle housing and the mower housing may help align them. Loosen the spindle to mower housing bolts and insert shim washers until the saddles are in line (Figure 50). Then, if you used washers to shim the spindle housing, remove the bolt and reassemble through the washer to secure it.

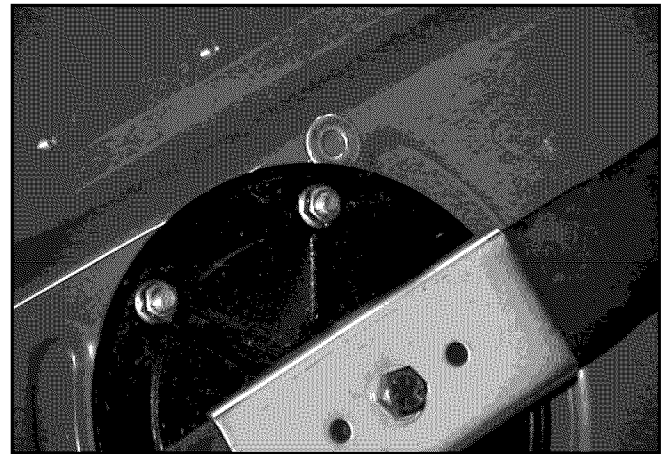

Figure 50

MVC-732X.JPG

Checking and Adjusting the Blade Level

260 Series Tractor

There are four mower attachments for the 260 series tractors. The process for adjusting the 38-inch (96.5cm) mower is different from that for adjusting the other mowers, and so it is described separately. The 42-, 48-, and 52-inch (106.6, 121.9, and 132.0cm) mowers all require the same leveling process, and so they are covered together. All four mowers require the same procedure for checking and adjusting blade tracking.



Figure 51 0318-29.TIF

38-inch (96.5cm) Mower

Adjusting Side-to-Side Level

The mower blades must be level from side to side. Check the side-to-side level any time you install the mower or when you see an uneven cut on the lawn. Before you level the mower, set the air pressure in the front and rear tires to 12 psi (83kPa).

This mower attachment is adjustable in two ways. One for higher heights of cut where the mower is suspended from the chassis and the other for lower positions where the level and height of cut are determined by the rear gage wheels.

In the 3-4 inch (7.6-10.1cm) range, the mower is suspended from the chassis. The two outside blade tips should be an equal height from the ground within 3/16 inch (4.76mm). If not, an adjustment is required.

1. Loosen adjustment bolt on one side of the tractor and rotate hanger bracket to raise or lower mower (Figure 52).
2. After adjusting, tighten the bolt and check side-to-side level.

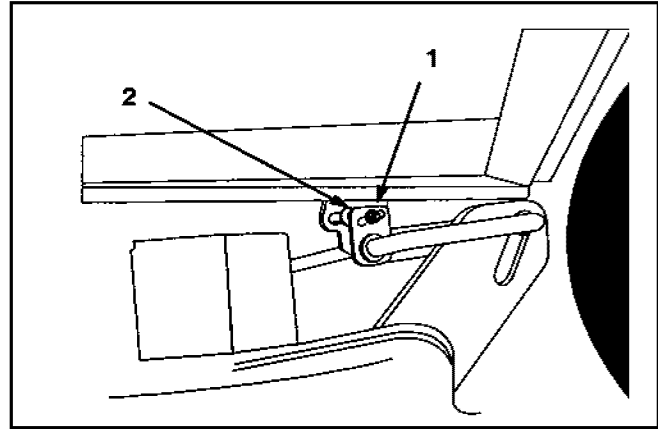

Figure 52 260_38_1.TIF

1. Bolt
2. Hanger bracket

IMPORTANT: If the hanger is rotated to the end of adjustment on one side and the mower is not level, adjust the opposite side.

In the 3/4-3 inch (19.0-76.0mm) range, the gage wheels contact the ground and determine the level. The blades should be level side to side within 3/16 inch (4.76mm) (Figure 53).

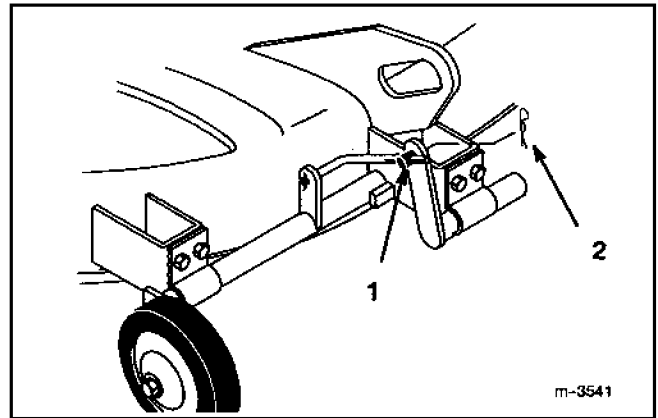

Figure 53 260_38_2.TIF

1. Trunnion
2. Hairpin cotter

Checking and Adjusting the Blade Level

1. Raise attachment lift lever to release pressure on the gage wheels. Remove the 7/16 inch (10.9mm) hairpin cotter from the trunnion (Figure 54).

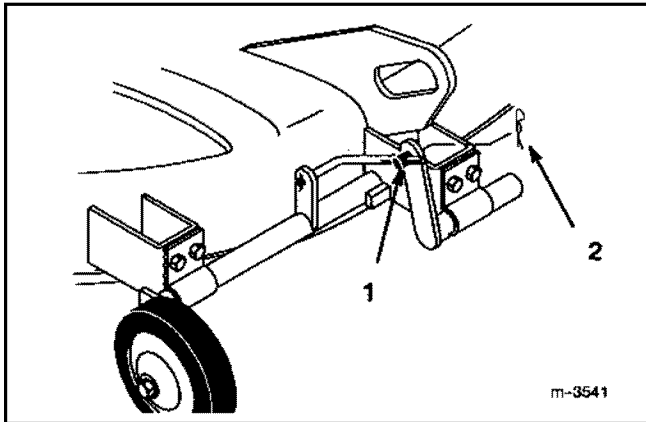

Figure 54 260_38_3.TIF

1. Trunnion
2. Hairpin cotter

2. Rotate trunnion to adjust side-to-side level adjustment.
3. After adjusting, secure trunnion with hairpin cotter and lower attachment lift. Check side-to-side level.

Adjusting Front-to-Rear Pitch

The front-to-rear pitch should be from 0-1/8 inch (0- 3.1mm) lower in front. To adjust the front-to-rear pitch, proceed as follows:

1. The adjustment link is on the right front corner of the mower. Loosen the jam nut on the link (Figure 55).

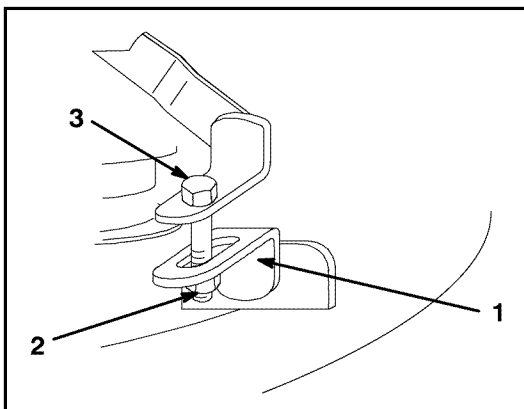

Figure 55 260_38_4.TIF

1. Adjustable link
2. Jam nut
3. Bolt

2. Rotate the bolt on front adjustable link to change front-to-rear pitch. Turn the bolt clockwise to shorten the link and raise the front of the mower. Turn counterclockwise to lower.
3. When the front-to-rear pitch is correct, tighten the jam nut. Recheck side-to-side leveling.

42-, 48-, 52-inch (106.6, 121.9, 132.0cm) Mowers

The side-to-level and front-to-rear pitch adjustments for all these models are the same. However, as you raise the cutting height, the point at which the rear gage wheels comes off the ground is different for the 52-inch (132.0cm) mower. There is an adjustment process when the mower is suspended. However, if the gage wheels are on the ground, there is no side-to-side adjustment. If the mower is not level side-to-side with the gage wheels on the ground, look for a worn or damaged wheel or bent gage wheel support (the bar that connects the gage wheels).

With the deck suspended, the height of cut range for the 42-inch and 48-inch (106.6cm and 121.9cm) mowers is 2-3/4–4 inches (69.8–101.6mm). For the 52-inch (132.0cm) mower, it is 3–4 inches (76-102mm).

The gage wheels on the 42-inch and 48-inch (106.6cm and 121.9cm) mowers are on the ground in the height of cut ranges 3/4–2-3/4 inch (19.0–69.8mm). The gage wheels on the 52-inch (132.0cm) mower are on the ground in the height of cut ranges 1-1/2–3 inches (38-76mm).

Checking and Adjusting the Blade Level

Adjusting Side-to-Side Level with Mower Suspended

The distance from the outside blade tips to the ground should be equal within 3/16 inch (4.6mm) (Figure 56). If not, an adjustment is in order.

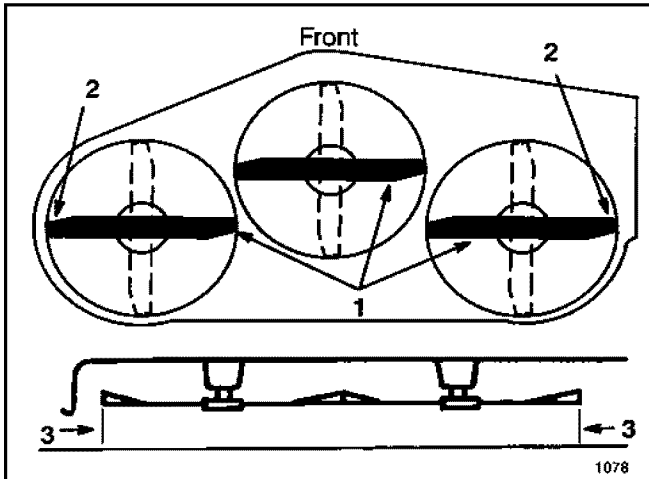

Figure 56

XL3bS2S.TIF

1. Blades side to side
2. Outside cutting edges
3. Measure here

1. Loosen adjustment bolt on one side and rotate hangar bracket to raise or lower mower.
2. After adjusting, tighten bolt and check side-to-side level.

IMPORTANT: If hangar is rotated to the end of adjustment on one side and mower is not level, adjust the opposite side.

Front-to-Rear Pitch

All mowers for the 260 series tractor use the same pitch measurement. The blade should be 0-3/8 inch (0-9.4mm) lower in front than in the rear. If it is not within this specification an adjustment is necessary.

1. To adjust the front-to-rear pitch, loosen jam nut on front adjustable link. **Note:** The 42-inch (106.6cm) mower comes with one adjustable link standard, although someone could have installed a second one. The 48-inch and 52-inch (121.9cm and 132.0cm) models have two adjustable links (Figure 57).

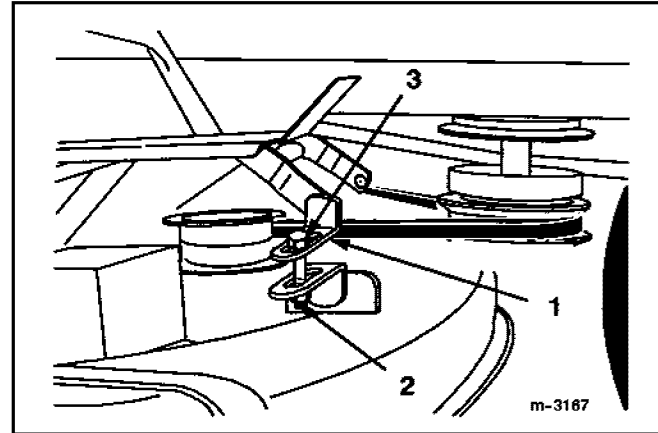

Figure 57

260XXF2R.TIF

1. Adjustable link
2. Jam nut
3. Bolt

2. Rotate the bolt on front adjustable link(s) to change the blade pitch. To raise the front of the mower, shorten the adjustable link by turning bolt clockwise. To lower front of mower, turn bolt counterclockwise.
3. When front-to-rear pitch is correct, tighten jam nut. Recheck side-to-side mower level (see "Adjusting Side-to-Side Level with Mower Suspended").

Blade Tracking—All 260 Series

On mowers with multiple blades, not only do the blades need to be a minimum of 1/8 inch up from the bottom edge of the housing, but they must also line up where the tips come together. Take the two blade tips and point them towards each other. They must be within 1/8-3/16 inch of level with each other, or both must be the same distance from the blade to the ground (Figure 58).

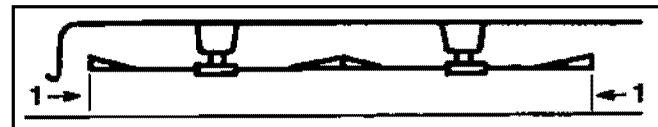

Figure 58

trclevel.TIF

1. Measure here

Checking and Adjusting the Blade Level

An alternate way to check this is to remove the mower housing and turn it over. Remove the blades and lay a straight edge on two blade saddles (Figure 59). It should lie flat. If not, either the spindle or the housing where the spindle mounts may be bent.

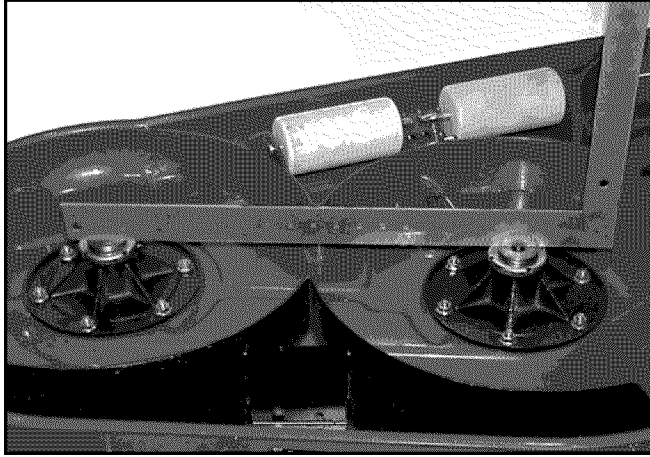

Figure 59

albltrk.TIF

Yet another way to check this with the blades attached is to align the blades (two blades at a time on three blade mowers), then run a string across the cutting tips of the blades. The string should be straight. If it is not, the blade or spindle could be bent.

If the saddles or blades do not line up and the spindles are not bent, a shim between the spindle housing and the mower housing may help align them. Loosen the spindle to mower housing bolts and insert shim washers until the saddles are in line. Then if you used washers to shim the spindle housing, remove the bolt and reassemble through the washer to secure it.

300-400-500 Series Garden Tractor (Excluding 5xi Series)

The mower attachments used on these tractors all have the side-to-side level and the height of cut determined by the rear gage wheels (Figure 60).

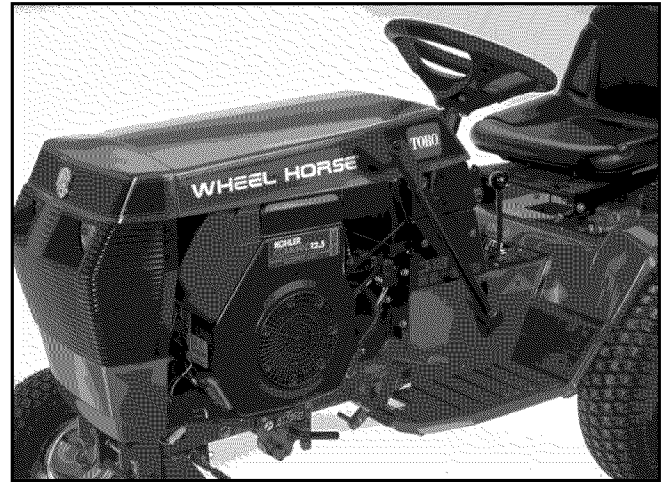

Figure 60

1380-09.TIF

Adjusting Side-to-Side Level

If the mower does not cut level side-to-side, check for a worn out gage wheel, a bent gage wheel support, or improperly tracking blades. Finding and correcting that should bring the side-to-side level back to normal.

Adjusting Front-to-Rear Pitch

The blade should be 1/8-1/4 inch (3.1-6.3mm) lower in front than in the rear. If it is not within specification, adjust the rear link.

Turn the locknut on the link (Figure 61). To raise the front of the mower, turn the locknut clockwise. To lower, turn the locknut counterclockwise.

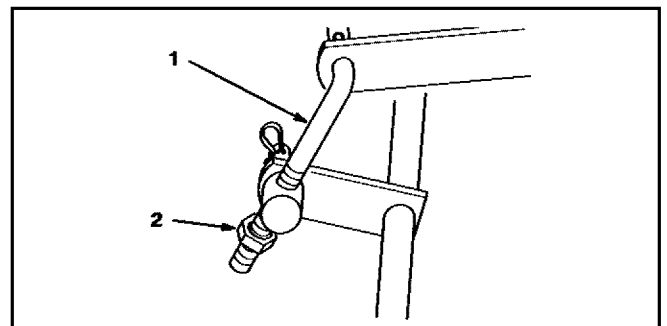

Figure 61

345gtF2R.TIF

1. Link

2. Locknut

Checking and Adjusting the Blade Level

Adjusting Blade Tracking

On mowers with multiple blades, not only do the blades need to be a minimum of 1/8 inch up from the bottom edge of the housing, but they must also line up where the tips come together. Take the two blade tips and point them towards each other. They must be within 1/8-3/16 inch of level with each other, or both must be the same distance from the blade to the ground (Figure 62).

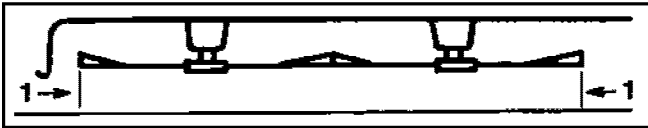

Figure 62

trclevel.TIF

1. Measure here

Another method is to remove the blades and place a straight edge between the blade saddles (Figure 63). They should be in line. If they are not, loosen the bolts securing the spindle housing to the mower housing. Insert shim washers and recheck. Once you have the alignment, remove the bolt and reinstall through the spindle housing, washer, and mower housing to secure the shim.

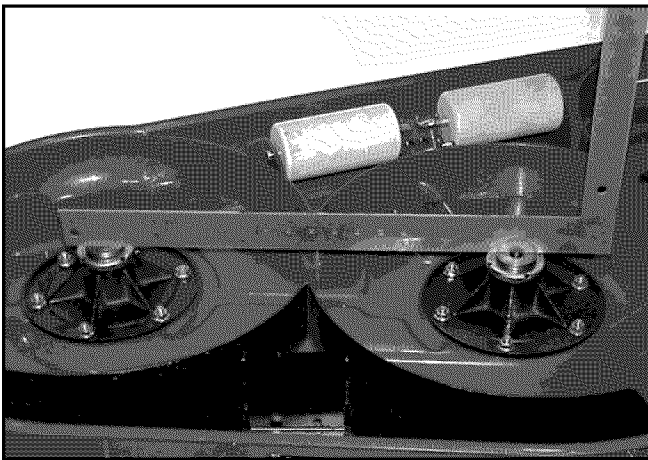

Figure 63

.TIF

Yet another way to check this with the blades attached is to align the blades (two blades at a time on three blade mowers), then run a string across the cutting tips of the blades. The string should be straight. If it is not, the blade or spindle could be bent.

If the saddles or blades do not line up and the spindles are not bent, a shim between the spindle housing and the mower housing may help align them. Loosen the spindle to mower housing bolts and insert shim washers until the saddles are in line. Then if you used

washers to shim the spindle housing, remove the bolt and reassemble through the washer to secure it.

5xi Series Tractors



Figure 64

0757-01-2.TIF

Adjusting Side-to-Side Level

All mower attachments for the 5xi series tractors should be level side-to-side within about 3/16 inch (4.76mm). However the adjustment point for the 60-inch (152.4cm) mower is different than the other models.

44-, 48-, 52-inch (111.7, 121.9, 132.0cm) Mowers

Equalize side-to-side cut by adjusting the two carriage bolts on the gage wheel shaft on the back of the mower (Figure 65).

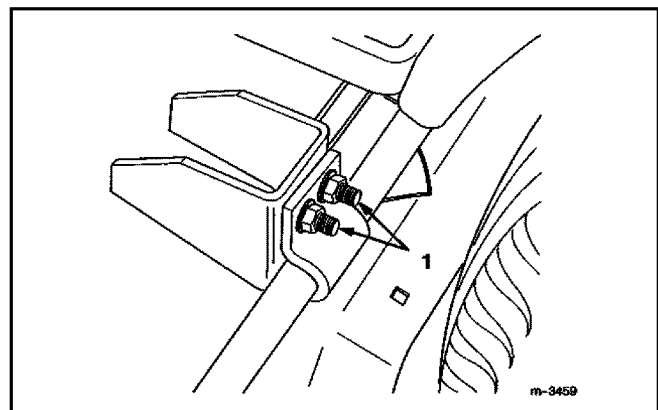

Figure 65

5XI_S2S1.TIF

1. Carriage bolts

Checking and Adjusting the Blade Level

60-inch (152.4cm) Mower

The mower blades should also be level side-to-side within about 3/16 inch (4.76mm). The adjustment is made on the gage wheels as shown (Figure 66).

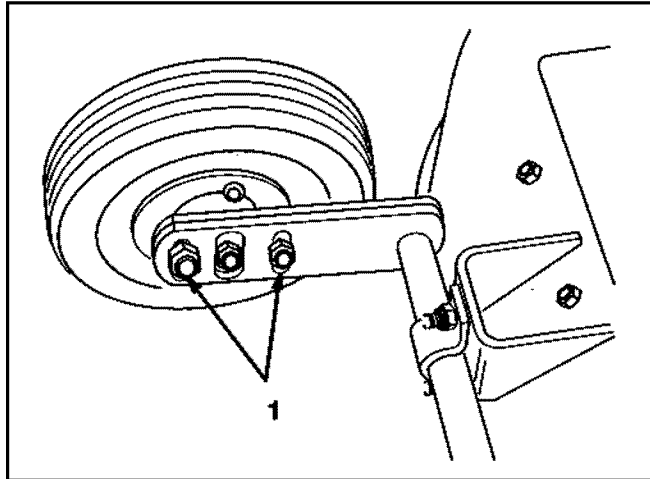

Figure 66

5300-004.TIF

1. Side-to-side adjustment bolts

Adjusting Front-to-Rear Pitch

All the cutting units for this series tractor should be adjusted so that the blade is approximately 1/8 inch (3.1mm) lower in front.

To adjust the pitch, turn the adjusting nut on the rear of the mower attachment. To raise the front of the mower, turn the adjustment nut clockwise. To lower the front of the mower, turn the nut counterclockwise (Figure 67).

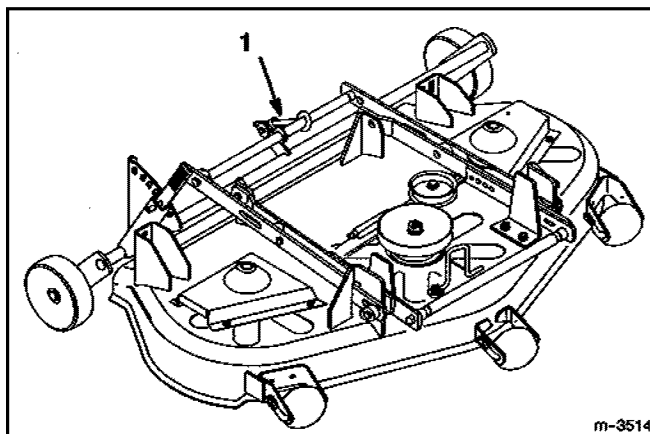

Figure 67

5XI_F2R.TIF

1. Adjusting nut

Adjusting Transport Blade Pitch

Because the attachment lift is used when the PTO drive is engaged, blade pitch in transport must be adjusted to extend PTO drive belt life. This adjustment also provides for adequate transport height. In the transport position, the blade tip should be about 1/4 inch (6.3mm) lower in front than in the rear. If adjustment is necessary proceed as follows:

1. Start the tractor, lower the attachment lift to take pressure off the adjustment cams. Stop the engine and remove the key.
2. Loosen the cam nuts and equally rotate the left-hand and right-hand cams down to raise the front of the mower, or up to lower the front of the mower (Figure 68). Tighten the nuts. Repeat as necessary.

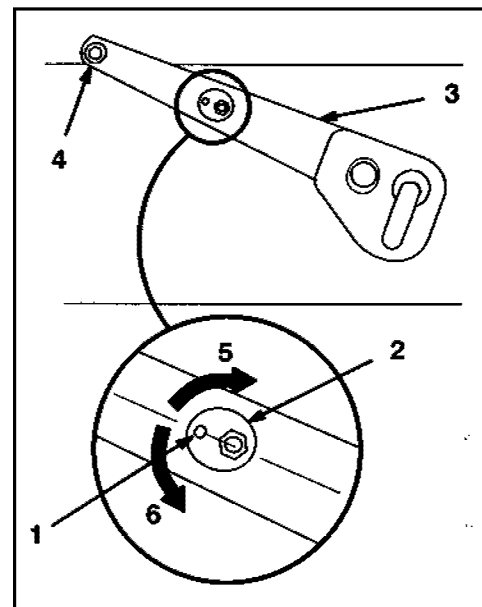

Figure 68

5XI_tran.TIF

Right Side of Tractor Shown

- | | |
|-------------------|--------------------------|
| 1. Indicator | 4. Pivot point |
| 2. Adjustment cam | 5. Lowers front of mower |
| 3. Lift arm | 6. Raises front of mower |

Checking and Adjusting the Blade Level

Adjusting Blade Tracking

On mowers with multiple blades, not only do the blades need to be a minimum of 1/8 inch up from the bottom edge of the housing, but they must also line up where the tips come together. Take the two blade tips and point them towards each other. They must be within 1/8-3/16 inch of level with each other, or both must be the same distance from the blade to the ground (Figure 69).

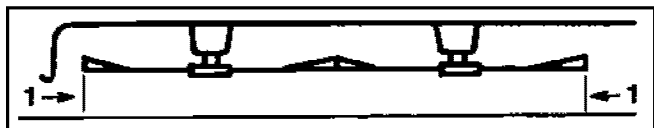

Figure 69

trclevel.TIF

1. Measure here

An alternate way to check this is to remove the mower housing and turn it over. Remove both blades and lay a straight edge on both blade saddles (Figure 70). It should lie flat. If not, either the spindle or the housing where the spindle mounts may be bent.

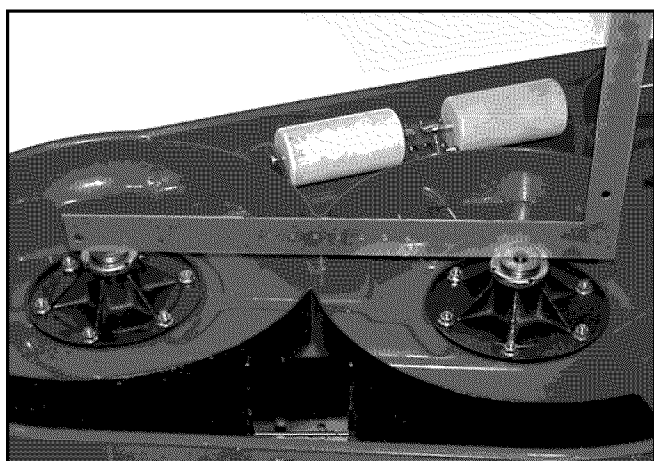

Figure 70

altbltrk.TIF

Yet another way to check this with the blades attached is to align the blades (two blades at a time on three blade mowers), then run a string across the cutting tips of the blades. The string should be straight. If it is not, the blade or spindle could be bent.

If the saddles or blades do not line up and the spindles are not bent, a shim between the spindle housing and the mower housing may help align them. Loosen the spindle to mower housing bolts and insert shim washers until the saddles are in line. Then if you used washers to shim the spindle housing, remove the bolt and reassemble through the washer to secure it.

TimeCutter Z

Note: This chassis was re-identified as TimeCutter ZX for 2003.

The TimeCutter ZX is sold with two mower sizes, 44-inch and 52-inch (111.7cm and 132.0cm) mowers (Figure 71).



Figure 71

2001-027.TIF

Adjusting Side-to-Side Level

These mowers should be level side-to-side within 3/16 inch (4.76mm). If adjustment is necessary, proceed as follows.

Remove the hairpin cotter and washer from the leveling bracket (Figure 72). To level the blades, reposition the leveling bracket in a different hole and install the washer and hairpin cotter. A front hole lowers the blade height and a rear hole raises its height. Adjust both sides as required.

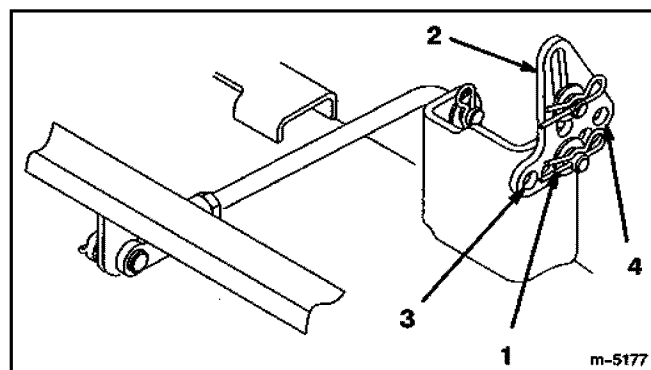

Figure 72

Z_S2S.TIF

1. Hairpin cotter and washer
2. Leveling bracket
3. Front hole
4. Rear hole

Checking and Adjusting the Blade Level

Adjusting Front-to-Rear Pitch

The mower blade should be between 1/16- 5/16 inch (1.6-7.9mm) lower in front than in the rear. If adjustment is necessary, proceed as follows:

1. To adjust the front-to-rear blade pitch, remove the hairpin cotter from the front trunnion yokes and loosen the jam nuts (Figure 73).

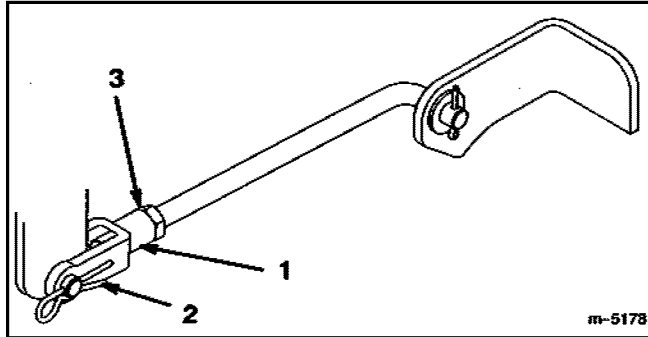

Figure 73

Z_F2R.TIF

1. Front trunnion
2. Hairpin cotter
3. Jam nut

2. Rotate the yokes on the rods to change the adjustment. To raise the front of the mower, tighten the yokes (shorten the rods). To lower the front of the mower, loosen the yokes (lengthen the rods).
3. After adjusting both trunnion rod yokes evenly, secure the yokes with the hairpin cotters. Check the front-to-rear pitch again. Continue adjusting the yokes until the front blade tip is within specification.
4. When the front-to-rear blade pitch is correct, tighten the jam nuts.
5. Recheck the side-to-side leveling and correct if necessary.
6. If the mower required substantial changes, check the anti-scalp rollers and re adjust if necessary.

Adjusting Blade Tracking

On mowers with multiple blades, not only do the blades need to be a minimum of 1/8 inch up from the bottom edge of the housing, but they must also line up where the tips come together. Take the two blade tips and point them towards each other. They must be within 1/8-3/16 inch of level with each other, or both must be

the same distance from the blade to the ground (Figure 74).

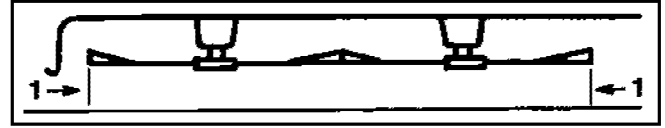

Figure 74

trclevel.TIF

1. Measure here

An alternate way to check this is to remove the mower housing and turn it over. Remove the blades and lay a straight edge on two blade saddles (Figure 75). It should lie flat. If not, either the spindle or the housing where the spindle mounts may be bent.

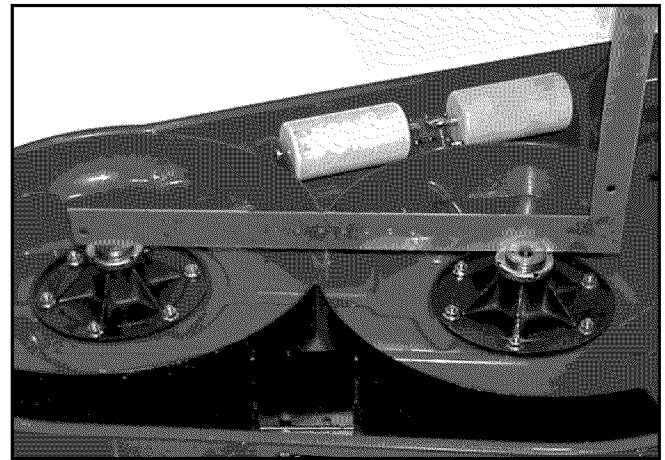

Figure 75

altbltrk.TIF

Yet another way to check this with the blades attached is to align the blades (two blades at a time on three blade mowers), then run a string across the cutting tips of the blades. The string should be straight. If it is not, the blade or spindle could be bent.

If the saddles or blades do not line up and the spindles are not bent, a shim between the spindle housing and the mower housing may help align them. Loosen the spindle to mower housing bolts and insert shim washers until the saddles are in line. Then if you used washers to shim the spindle housing, remove the bolt and reassemble through the washer to secure it.

This page intentionally left blank.



Troubleshooting Quality of Cut

This section contains some common complaints along with actions that will normally resolve the complaints described. To keep the section brief and easy to use, we make no attempt to explain how the suggested action resolves the problem. Definitions of the terms used here are in the Glossary in the Appendices of this manual.

Note that a good quality of cut is achieved by several factors working together. Any "will fit" parts should be replaced with OEM parts before troubleshooting. It is difficult to determine if a part meets the original specifications if it is not the original manufacturer's part. Small variations can change the performance noticeably. Use only OEM parts intended for the machine.

General Troubleshooting Procedures

While many problems with quality of cut require specific actions to resolve, there are a few things that are generally common to most problems. To avoid duplication, these are stated here. In most cases, these items should be verified before going to more specific suggestions.

Note: A new lawn can exhibit several of the quality of cut problems. Most of these will resolve themselves when the lawn begins to thicken to a normal level.

1. Cut late in the day after the sun has had an opportunity to dry the grass.
2. Keep the engine at full RPM. Verify RPM with a tachometer. Engine speed should be within the manufacturer's recommended speed specified range, not lower or higher.
3. Walk or drive more slowly.
4. Move over and take less than a full width cut.
5. Check for grass build-up in cutting chamber.
6. Raise the height of cut and cut the lawn. Come back a day or two later and re-cut to the preferred height.
7. Check for a sharp blade. Sharpen as instructed in the Operator's Manual.

8. Check for belt slippage on mowers using a belt in the blade drive system (Toro BBC, Riding Mowers, and Wide Area Mowers).
9. Keep the right (discharge) side of the mower over previously-cut grass.

Specific Quality of Cut Problems and Possible Solutions

Following are descriptions of specific quality of cut problems and possible solutions to them. If the general troubleshooting procedures previously described do not resolve a quality of cut problem, look for the problem and its possible solution(s) in the following descriptions.

Blowout

1. If bagging or side discharging, look for and remove any restriction to airflow. A plugged air exhaust in a bagger for example, or a plugged chute when side discharging or bagging.
2. If the blade pitch is fairly flat front to rear, raise the rear of the mower slightly.
Note: Do the opposite if you are bagging leaves and the mower pushes them away instead of picking them up.
3. Check to see if a blowout kit (sometimes called a baffle kit) is available for the model. See "Special Tools" in the Appendices.

Clumping

Toro Recycler mowers and mulching mowers can be more susceptible to clumping because the clippings stay in the chamber longer than in other types of mowers. If the general troubleshooting procedures previously described do not resolve the problem,

1. Convert the mower to side discharge for at least one mowing.
2. Convert the mower to bagging for at least one mowing.

Troubleshooting Quality of Cut

Clogged Chute (Bagging or Side Discharging Only)

1. Check for an alternate blade. A low lift blade on a bagging mower may have an increased tendency to plug. Install a higher lift blade if available.
2. On bagging mowers, the air exhaust may be restricted. Ensure that the bag is not caked with dirt and the air exhaust screen is not clogged.

Dribbling

Dribbling is caused by the same factors as clumping. Use the same steps to remedy this problem.

Ragged Cut

1. Weed content—Some weeds and weedy grasses are very difficult to cut cleanly, leaving a poor looking lawn. Remove the weeds from the lawn or improve the grass stand in the lawn.
2. Grass variety—Some types of grass can be difficult to cut. Certain varieties, such as Annual Rye and Bahia are tough, stringy, and are difficult to cut cleanly no matter how sharp the blade.

Scalping

1. Raise the height of cut to avoid high spots.
2. The lawn may need to be graded or rolled to remove high spots.
3. Level mower side to side.
4. Adjust anti-scalp devices.
5. Adjust gage wheels on floating or semi-floating decks.
6. Reduce ground speed, either in turns or on straight runs.
7. Change cutting pattern. Sometimes approaching a high spot from a different angle resolves the problem.
8. If the mower attachment scalps only on turns, slow down. High speed turns can cause the side of the mower on the inside of the turn to lift or bounce and this makes the outside edge dig into the ground. Centrifugal force will apply in direct relation to the speed.

Stair Step or Sawtooth Cut

Check mower for level side to side.

On multi-blade mowers, verify all blades are at the same height.

Stragglers

1. Check the blade pitch. See the Operator's Manual or the section "Checking and Adjusting the Blade Level" of this manual for adjustment instructions.
2. If the mower is equipped with an accelerator or mulch fan, replace it with a blade stiffener as used on some bagging mowers. Not all mowers require this.
3. Try a lower height of cut.
4. Check for heavy foot traffic in area affected. Heavy traffic will compact the grass.

Streaking

1. Check the blade pitch. See the Operator's Manual or the section "Checking and Adjusting the Blade Level" of this manual for adjustment instructions. In severe cases, adjust mower pitch to zero (level, front to rear).
2. Check for the correct blade—a bagging blade used when mulching may cause excessive turbulence.
3. If the mower is equipped with an accelerator or mulch fan, replace it with a blade stiffener as used on some bagging mowers. Not all mowers require this.
4. Try varying the height of cut.
5. Multi-blade decks may leave a streak when turning in uncut grass when the effective direction of the mower eliminates the blade overlap. This may happen in long, curved cutting patterns. Try making the turn from the opposite direction, if possible.
6. Verify the correct blade overlap if a multi-blade mower leaves a streak between blades when traveling in a straight line. This can happen when the blades have been sharpened numerous times, making them too short.

Troubleshooting Quality of Cut

7. Verify that there is not a gage wheel or roller pushing the grass down before the blade can cut it.
8. Excessive toe in on front tires can push the grass down to the point where the mower might have difficulty pulling it up to cut it. Check and adjust as needed.
9. Blades that are short or have worn sails do not provide the air flow to stand the grass up. Replace worn blades.
10. The grass may be compacted after being cut. The rear tires and rollers or gage wheels on the rear of the mower will knock the grass down, too. What may appear to be a streak may be grass that the tires or gage wheels did not hit. If so, the rest of the grass will straighten up in a day or so and the lawn will be level. To test for this, brush the grass with your hand to see if it is level. If so, the problem could be compaction. This occurs frequently when the grass is too wet or too dry.
11. On multi-blade decks, what is described as a streak can result from two of the blades not being aligned, and therefore cutting at two different heights; this is actually a stair step cut. On multiple blade mowers the blade tips should be in line within 1/8 inch. See the operator's manual or the section "Checking and Adjusting the Blade Level" of this manual for instructions on checking and repairing this problem.

Uncut Grass

1. Verify the correct blade is being used. Some models have different blades for mulching versus bagging.
2. Check the blade pitch. See the Operator's Manual or the section "Checking and Adjusting the Blade Level" of this manual for adjustment instructions.
3. Try a lower height of cut and slower ground speed.

Windrow

1. Wet or extremely lush grass windrowing can usually be resolved by following the general suggestions.
2. Dry grass windrowing indicates the operator is trying to process too much grass at one time. One or more of the general suggestions should resolve this problem.
3. If side discharging, ensure grass is being thrown into the previously-cut area.

This page intentionally left blank.



Kits to Improve Quality of Cut

This section describes special kits developed to help resolve various quality of cut issues.

Toro Recycler Mulch Plug

Model 59134 fits Toro 21-inch Recycler Steel Decks
Model 59135 fits Toro 21-inch Super Recycler Cast Aluminum Decks

These plugs smooth the surface under the deck while adding an additional deflector. They fit in the bagging chute and prevent grass accumulation in that space.

Washout Port Kit P/N 95-3282

This kit (Figure 76) allows an operator to attach a garden hose to the deck and circulate water under the deck by engaging the blade while the water is running. This prevents grass buildup under the deck.

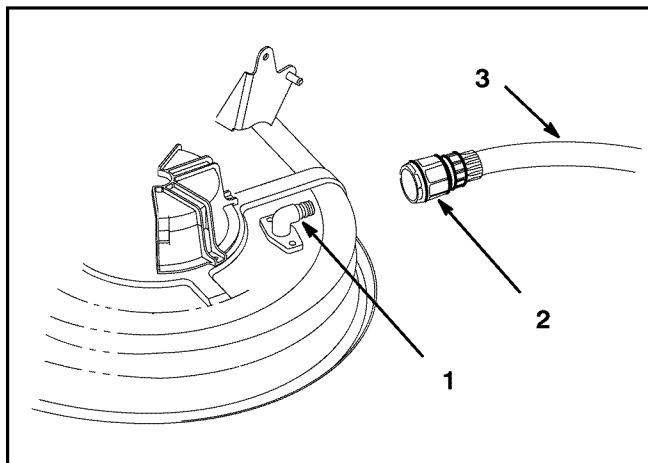

Figure 76

washout.TIF

1. Washout fitting
2. Coupling
3. Hose

If the underside of the deck is not cleaned after mowing, the accumulated grass can dry out and bond to the deck. Once this happens, the hard material must be scraped from under the deck. This often removes the protective paint from under the deck.

With a washout port kit, it is easy to hook up a garden hose and clean the cutting chamber after each use. Many models currently have this kit factory installed. However, it can be used on most models by finding a place where the water can run into the cutting chamber and not hit a kicker or other object.

Cast Deck Height of Cut Notch Repair Kits

P/N 105-1290 (Figure 77) fits 21-inch (35cm) Super Recyclers built 1995 and newer.

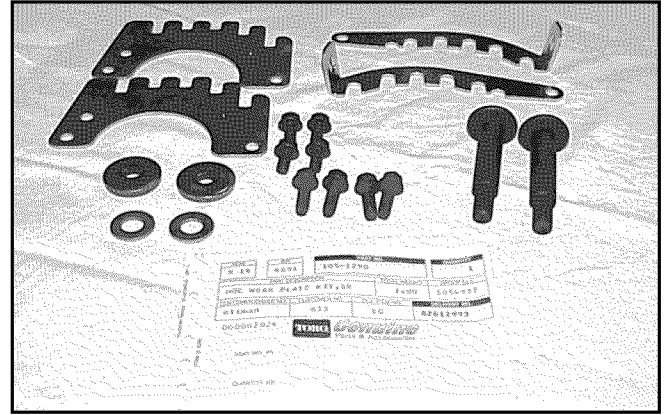

Figure 77

mvc-460.tif

P/N 49-4080 (Figure 78) fits 21-inch (35cm) Rear baggers and Recyclers 1978 through 1994.

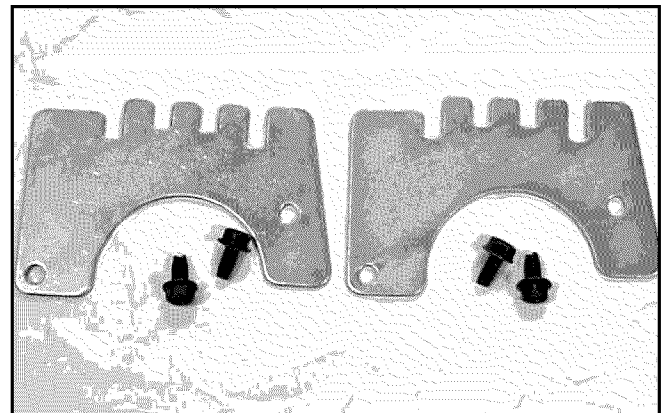

Figure 78

2001-065.TIF

These kits are used to repair cast decks with worn height of cut notches. The kits allow the operator to avoid replacing the deck.

Note: These kits do not fit Vacu-Power, Landscaper, or commercial walk behind mowers.

Kits to Improve Quality of Cut

Anti-scalping Roller Kit P/N 93-3898

Used on Toro Wheel Horse XL series 38-inch decks, this kit adds rollers to the deck to help avoid scalping on uneven lawns. Rollers are standard on European models.

Level Assist Kit P/N 94-9780

This kit can be used on 260 Series Lawn and Garden tractors to help keep the mower deck level when using a vac-bagger attachment. (Standard on 2001 and later vac-baggers.)

Level Assist Kit P/N 94-1592

This kit can be used on garden tractor mowers to help keep the mower deck level when a vac-bagger attachment is used. (Standard on 1997 and later vac-baggers.)

Baffle Kits

Baffle kits are available for some mowers. These are designed to help reduce the tendency to blow leaves and dry grass out the front of the mower. If a mower has Recycler baffles and kickers, try to resolve the blowout problem by removing these prior to purchasing and installing a baffle kit. Baffle kits work by deflecting airflow when mowing or bagging leaves.

Baffle Kits/Applications

Kit Number	Mower Application
85501	42-inch (3 blade) Side Discharge Mowers
105-6979	44-inch (3 blade) Side Discharge Mowers (Recycler Baffles must be removed)
68-7210	52-inch Side Discharge Mowers

This section includes three subsections:

- Glossary—a list of terms used in this manual
- Special Tools—a list of special tools required for the procedures described in this manual
- Quality of Cut Checklist—a form to copy and use when troubleshooting quality of cut problems

Glossary

These terms apply to all rotary mowers and provide a common vocabulary about quality of cut issues.

Accelerator—a fan-like part mounted next to the blade on some mulching mowers. The accelerator creates air turbulence and helps evacuate clippings from the cutting chamber. The accelerator also provides support to the middle of the blade.

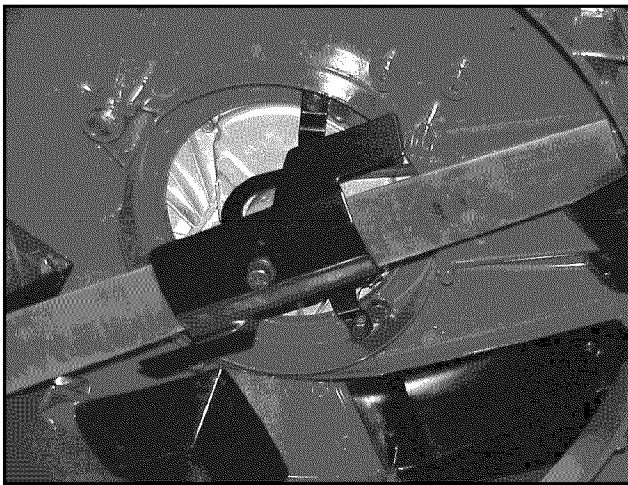

mvc-401x.jpg

Airflow—is the movement of air created by the mower blade. Air is pulled from under the lower edge of the cutting chamber. This flow of air stands the grass up so the blade can cut it. The grass clippings are then directed to the discharge opening, bag, or, when mulching, down onto the lawn. The type and speed of blade, shape of the housing, and the amount of space for the air to enter and exhaust determine the amount and speed of the air.

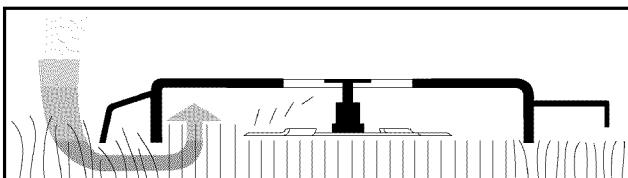

airflow.TIF

Anti-scalp wheel—a wheel that contacts the ground only momentarily to prevent scalping when a mower encounters a high spot or crest in the lawn. Anti-scalp wheels cannot prevent all scalping but they reduce the incidence in most situations.

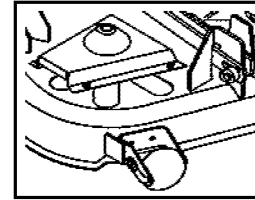

antisclp.TIF

Bagging chute—the duct or chute that directs airflow and grass clippings into the bag on a bagging mower.

Bagging mower—a type of mower that collects the grass clippings in a hopper or bag.

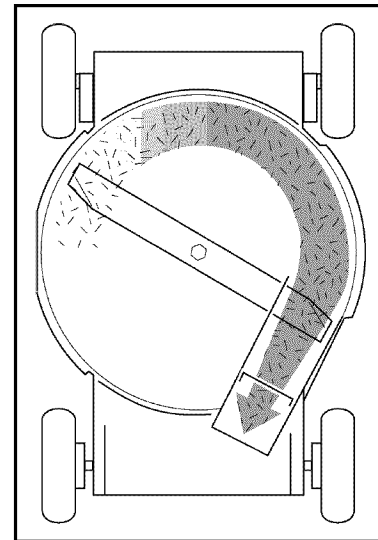

bagmower.TIF

Appendices

Blade—rotary mowers use a blade, usually steel, to provide the fan action that provides the airflow to stand up, hold, and transport the grass clippings. The blade also cuts the grass with a sharpened edge. The parts of the blade affecting airflow and grass cutting are identified in the following figure.

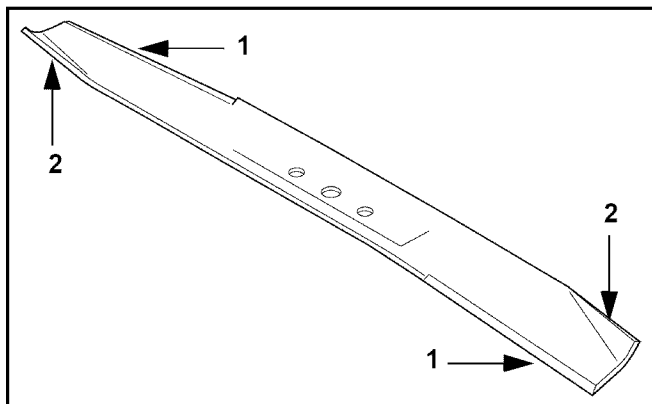

blade.TIF

1. Cutting edge
2. Sail

Blade tracking—Blade tracking refers to the path the blade tip follows as it rotates within the housing. A normal track is a minimum of 1/8 inch above and parallel to the lower edge of the mower housing.

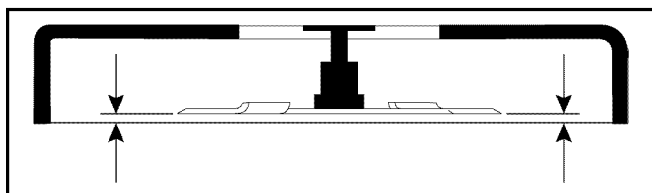

bltrack.TIF

Blowout—a condition in which the mower throws clippings from under the mower housing somewhere other than the discharge chute. This term is normally used when the clippings fall back onto the mower, or the operator, when moving forward.

Chute—a duct used to control the movement of grass from the mower. This term commonly refers to either the discharge chute or the bagging chute on a mower.

Chute plugging—when grass clippings bunch up and clog the discharge chute or the bagging chute.

Clip rate—the number of cutting blade passes over a given distance the mower travels. Clip rate is a way to measure how many opportunities the mower blade has to cut an individual blade of grass. See the following chart. (Calculations are based on a 21-inch blade rotating at 3,000 RPM.)

Ground Speed/Blade Passes

Ground Speed (MPH)	Clips per Foot Moved Forward	Clips per Inch Moved Forward
1	68.18	5.68
2	34.09	2.84
3	22.72	1.89

Clumping (wet grass)—when the clippings come out of the mower in bunches or piles. If the clippings are stuck together, moisture is usually the cause. The moisture source can be either external (rain or dew) or internal (dry ambient conditions but very lush grass).

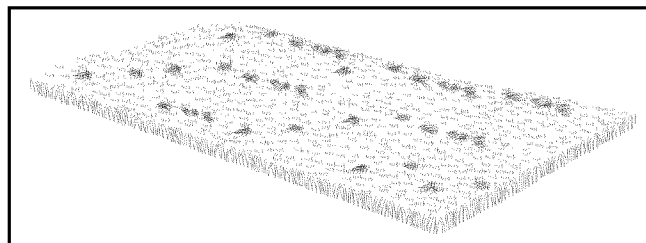

clumpwet.TIF

Clumping (dry grass)—similar in appearance to wet grass clumping but can occur in very dry conditions. The clippings will fall out in bunches but will not be stuck together. This may be more accurately termed a windrow where the clippings are not in a continuous row.

Convertible mowers—mowers intended to be converted from side discharging to mulching to bagging. These mowers are good at each function, but cannot be optimized for all three functions without changes. Kits are available for some mowers to add an additional function.

Cut path—the area that the mower covers in one pass.

Deflector—a part designed to change the direction of cut grass. A deflector is usually attached to the discharge chute or is a part of the design of the discharge chute.

Density—the number of grass blades in a defined area, usually one square foot. A lawn that has more grass plants per square foot is referred to as more dense or thicker than a lawn with fewer plants per square foot.

Disbursement—describes how well a mower spreads or disburses the clippings.

Discharge Chute—the opening in the mower cutting chamber that allows the cut grass to be discharged from the mower.

Engine RPM (revolutions per minute)—a measurement of the speed the engine is running.

Floating deck—a mower that is free to follow the terrain separately from the tractor through the use of gage wheels. This term is often applied to decks that are actually semi-floating.

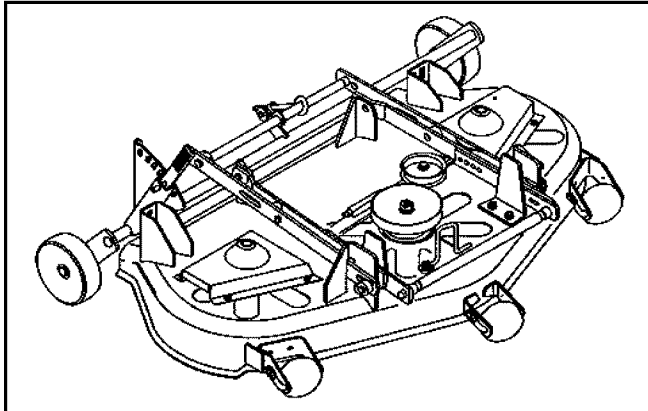

flotdeck.TIF

Gage wheels—an adjustable wheel that determines the height of cut. The gage wheel is in contact with the ground all the time a full-floating mower is cutting.

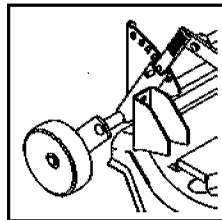

gagewh.TIF

Ground speed—the rate at which the mower travels across the ground.

Halo—a noticeable circle of clippings dropped by a mower, usually when a mower is stopped.

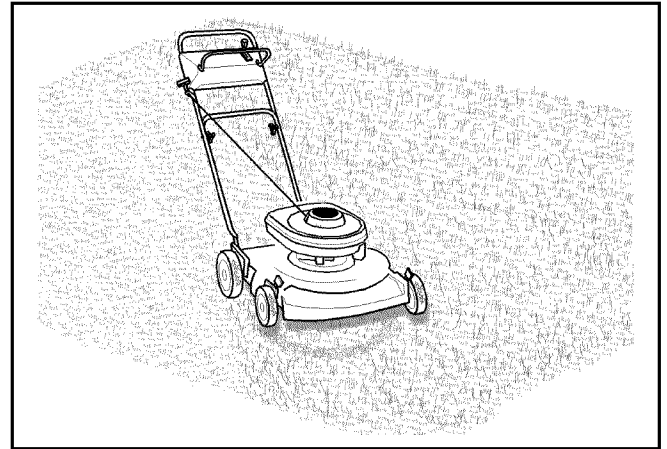

halo.TIF

Height of cut (HOC)—the measurement from the ground to the top of the grass blade after it is cut, or from the ground to the cutting edge of the mower blade (these should be the same).

Leveling—the process of adjusting the mowing deck so that the blade is correctly positioned relative to the ground. See the instructions for the particular mower for the correct adjustment method and measurements.

Lush grass—grass with a high water content. This is common in most areas during spring rains or on a lawn that is watered heavily. This term may be used in conjunction with density, as in "lush dense grass".

Mulching—using the mower to cut grass into very small pieces and deposit it back into the lawn.

Mulching fan—See Accelerator.

Mulching mower—a mower used to mulch grass. This term is used to describe mowers that are designed specifically to mulch and convertible mowers that mulch.

Peak torque—the speed at which an engine applies the maximum twisting force to the crankshaft. This is the speed where the engine can do the most work.

Pitch—the front-to-rear position of the blade in relation to the ground.

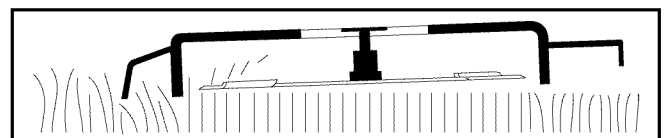

pitch.TIF

Appendices

Power band—the RPM range where an engine produces its best power. This range is usually below wide-open throttle but above peak torque. As the grass load slows the engine, the RPM drops to near peak torque. Wide-open throttle and peak torque are the two ends of the power band.

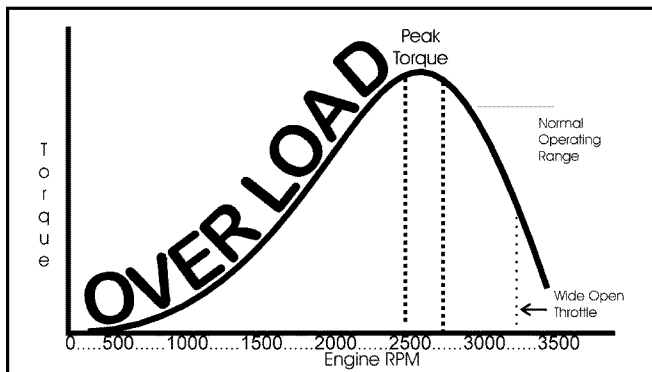

5300-005.TIF

Ragged cut—grass blades are not cut cleanly or the edge is shattered. A cleanly cut grass blade has a small dead area at the tip. After a few days, a ragged cut looks like a brown or gray haze at the top of the grass.

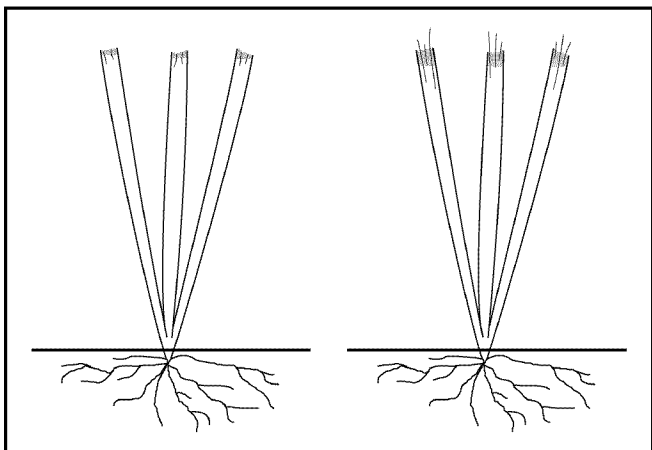

raggdcut.TIF

Rake—see Pitch.

Recycler—Toro's patented mulching system.

Rough terrain—terrain uneven enough to affect the quality of cut by causing the mower to bounce excessively.

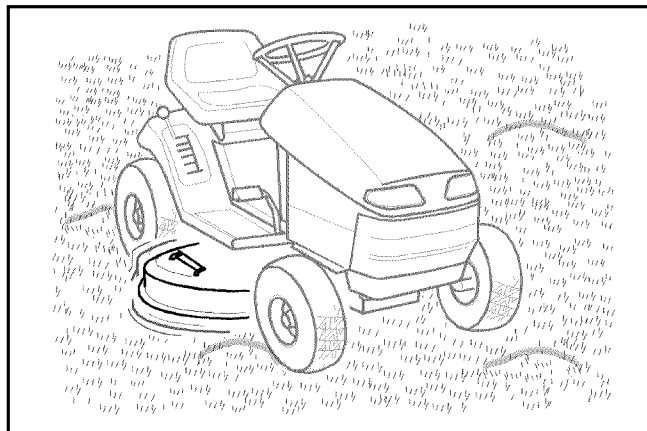

terrain.TIF

Scalping—when the blade cuts the grass at ground level or actually strikes the ground and removes earth.

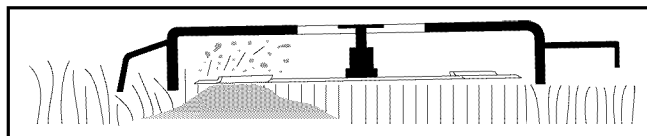

scalp.TIF

Semi-floating deck—a type of mower that is partially supported by the chassis but also has wheels on the ground.

Side discharge mower—a mower that has an opening to eject the clippings to one side. This type mower may also be convertible to other functions.

Slope—see Pitch.

Suspended deck—a mower fully-suspended from the tractor. Height of cut is controlled by raising or lowering the mower attachment through linkage attached to the tractor.

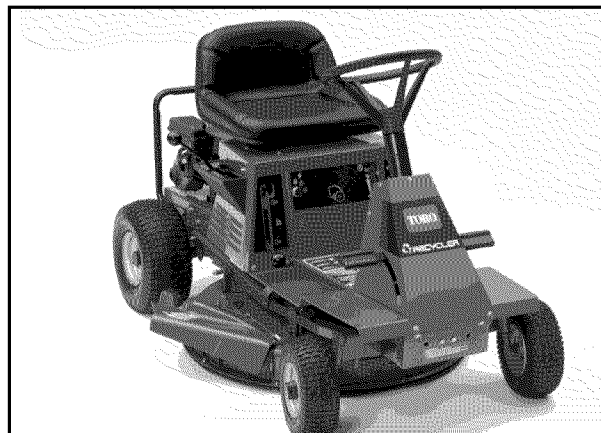

1222-05.jpg

Stragglers—random, individual blades of grass that are not cut when the mower has passed over an area.

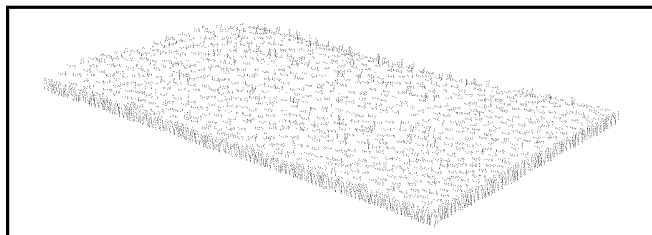

5300-023.TIF

Streaking—a strip of uncut or partially-cut grass. A streak can be a continuous or broken line or strip of grass. It can occur during straight runs or only when making turns.

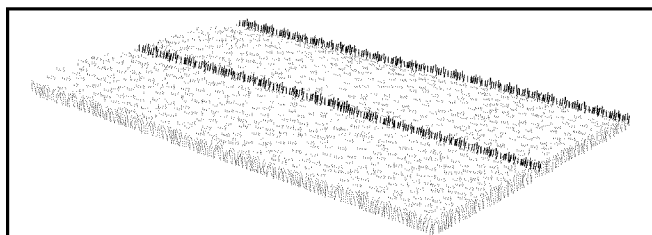

5300-017.TIF

Tall grass—grass that is so long that it makes it hard to follow the 1/3 rule. Generally this is grass 6 or more inches tall.

Thatch—the tough fibrous part of the plant, similar to a root, that is above ground but growing laterally rather than up, sometimes combined with grass clippings that have not decomposed. Some types of grass create little thatch; others need the thatch to be removed periodically.

Thin / Thick grass—the density or the number of plants in a specific area. The density of the grass is a factor in how much volume of grass the mower is asked to process and in how readily air can enter the cutting chamber.

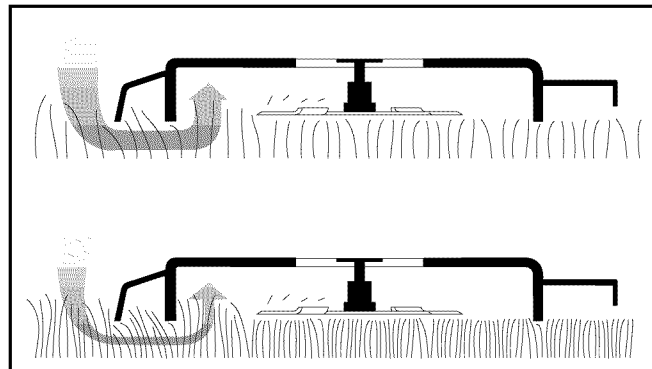

thinthik.TIF

Tire tracks—grass pushed down when a mower is rolled across a yard. Normal, healthy grass will recover from this in a day or so. Overly-lush or very dry grass may take longer to straighten up. The grass in a lawn affected this way may also retain footprints after some one has walked across it.

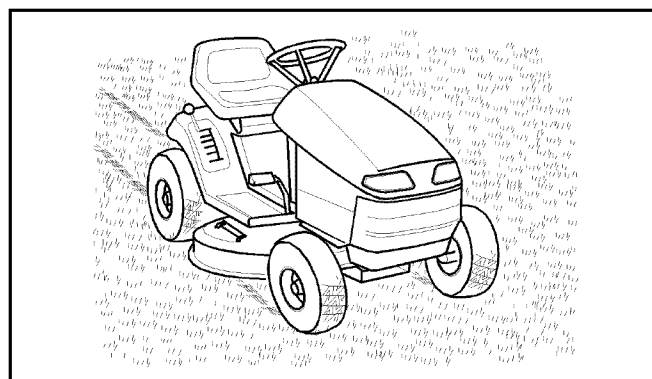

5300-061.TIF

Appendices

Uncut grass—grass left standing after a mower has passed over it. This usually refers to grass that is not cut at all, as opposed to grass cut longer than the mower's height of cut setting should leave. This term can also refer to an area of grass that has not been cut or passed over by a mower.

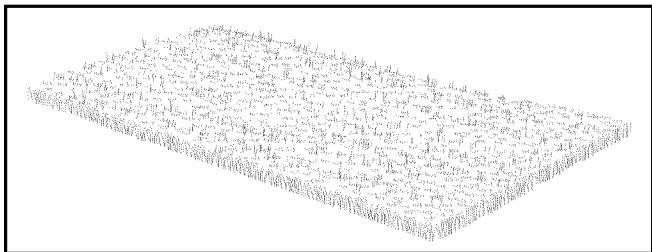

5300-031.TIF

Unlevel cut—a cut path with an inconsistent height of cut.

Wet grass—grass that is wet to the touch. Rain, watering, or morning dew can be the source of the moisture.

Windrow—poor disbursement of clippings resulting in a nearly continuous line of cut grass clippings on the grass. This may also appear as clumps of dry grass, generally in a row across the lawn.

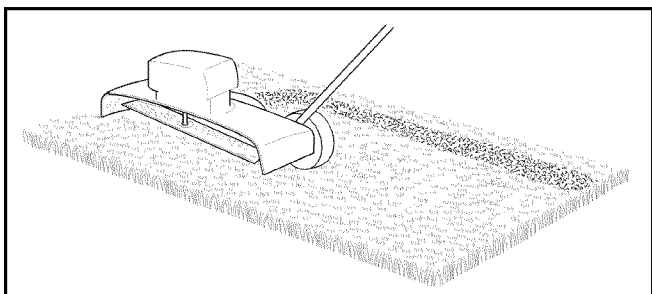

windrow.TIF

1/3 Rule—a recommendation by turf grass agronomists that not more than 1/3 of the height of the grass be removed at one time to maintain the health of grass plants. Most rotary mowers designed for urban and suburban lawns are designed to work best when operators follow this rule.

Special Tools

Normal hand tools will be needed when correcting a quality of cut complaint. However, there are a few special items that will be a big time saver.

- **Height of cut measuring tool.** This tool has an arm that is slid under the mower attachment and pushed up to the bottom of the blade. The indicator reads the height of cut.

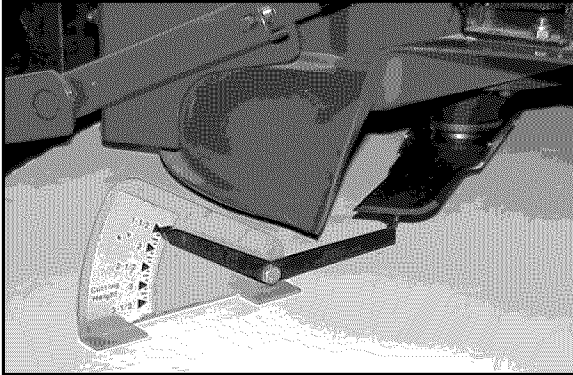

MVC-732X.jpg

An alternate height of cut tool can be created in the shop. A wooden dowel that can be placed perpendicular to the floor can be used. The dowel needs to be taller than the height of cut to be measured, but not so tall as to hit the top inside of the mower deck. Wrap any kind of tape around one end and down far enough to reach the blade. Reach under the housing, place one end of the dowel on the ground, and stand it upright. Using the sharp edge of the blade, make a mark in the tape. Pull the dowel out and measure from the end to the mark. That will be the height of cut.

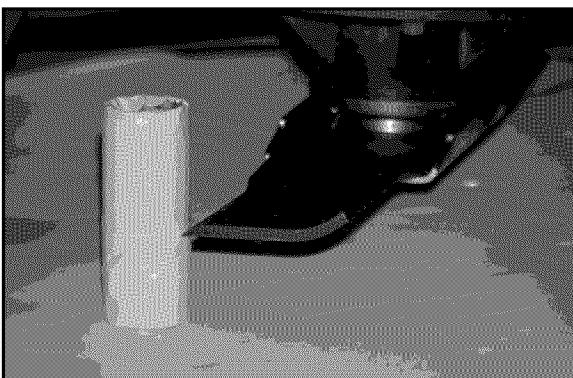

MVC-728X.jpg

- **A smooth flat surface.** When measuring height of cut, do not assume your floor is flat. Use a

known straight edge to check the floor. Remember you will be trying to measure within 1/8 inch or less. Many shop floors are not that flat. A good solution is to lay a sheet of plywood on the area to be used. A 4 X 8 foot sheet of 3/4 inch thick material with one smooth side is adequate for most mowers.

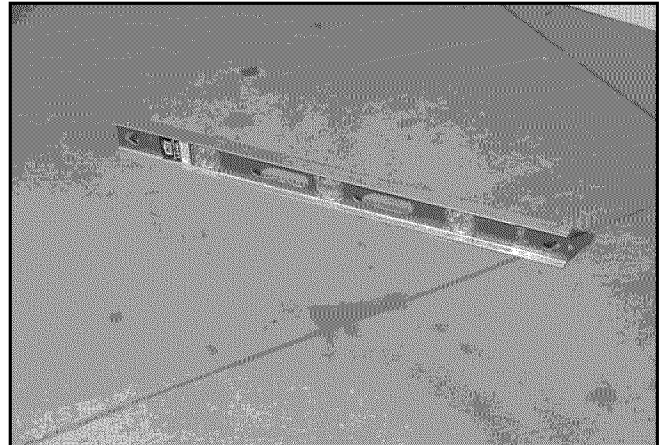

MVC-715X.jpg

Appendices

- **A reference board.** A reference board can be easily made. Use a board that will span the width of cut of the mowers you will be checking. Mark off level regular lines on your board, one-inch intervals are recommended. Place at least one stake on either end, so they can be pushed into the ground and hold the board up. If you handle riders and tractors, you may wish to make the board as wide as the largest mower attachment that you handle. For ease of handling, the board can be hinged in the middle. This also allows storage in a smaller area.

To use the board, cut a path with the mower being checked. Place the board across the path and brush the grass with your hand. Now stand back from the board and look at the grass against the reference line. You will be able to see any uncut strips, out of level, or other quality of cut issues.

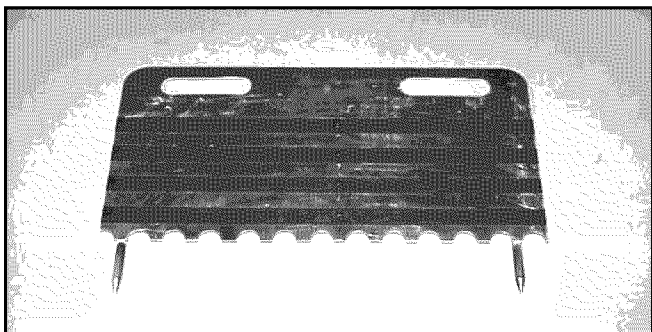

MVC-714X.jpg

Mower Quality of Cut Checklist

The following page contains the Mower Quality of Cut Checklist. When troubleshooting quality of cut problems, copy this form and use it to record information about the problem, the troubleshooting steps you take, and the results.

Mower Quality of Cut Checklist

Customer name _____ Date _____

Walk behind or riding mower model/VIN _____ S/N _____

Mower attachment model/VIN _____ S/N _____

Bagger model/VIN _____ S/N _____

Clipping disposal: Side discharged Mulched Bagged

1. Complaint: Streaking Ragged cut Windrow
Clumping Other: _____

2. Description of problem: _____

3. Is a vacuum or sweeper being used? Yes No

4. Service/Check/Adjust—in shop	Yes	No
A. Underside of mower housing clean?	<input type="checkbox"/>	<input type="checkbox"/>
B. Blades sharp and in balance?	<input type="checkbox"/>	<input type="checkbox"/>
C. Blades too short, bent, or not aligned with each other?	<input type="checkbox"/>	<input type="checkbox"/>
D. PTO/belt drive/spindles in working order?	<input type="checkbox"/>	<input type="checkbox"/>
E. Tire pressure the same on all tires? (Riders usually 12 PSI.)	<input type="checkbox"/>	<input type="checkbox"/>
F. Engine maximum RPM to specification?	<input type="checkbox"/>	<input type="checkbox"/>
G. Mower level side to side with 1/8 inch?	<input type="checkbox"/>	<input type="checkbox"/>
H. Bagging system clean, air exhausts open, impeller drive in working order?	<input type="checkbox"/>	<input type="checkbox"/>
I. Mower level front to rear? (Most tractors 1/8 inch low in front. 32-inch mowers, 20-inch and 21-inch walk behind mowers approximately 3/8 inch low in front.)	<input type="checkbox"/>	<input type="checkbox"/>

5. Observations from watching customer operating mower (if possible): _____

6. Check	Yes	No
A. Engine being run at full throttle?	<input type="checkbox"/>	<input type="checkbox"/>
B. Cutting height of mower _____		
C. Measured height of grass _____		
D. Mowing speed suits conditions?	<input type="checkbox"/>	<input type="checkbox"/>
E. Grass is wet or extremely lush?	<input type="checkbox"/>	<input type="checkbox"/>
F. Unusual terrain causing a problem?	<input type="checkbox"/>	<input type="checkbox"/>
G. Operator turning too sharp or fast?	<input type="checkbox"/>	<input type="checkbox"/>
H. Accessories (weights, chains, etc.) causing problems?	<input type="checkbox"/>	<input type="checkbox"/>

7. If the quality of cut is still not satisfactory, raise the front of the cutting chamber.
On riding mowers with adjustable pitch, raise the front to 1/8 inch above level.
On walk behind mowers, raise the front one notch.
Test operation after adjusting pitch.

Results: _____

This page intentionally left blank.



QUALITY OF CUT MANUAL