

NordicTrack® SE 3i

Model No. NTEVEL57019.0

Serial No. _____

Write the serial number in the space above for reference.

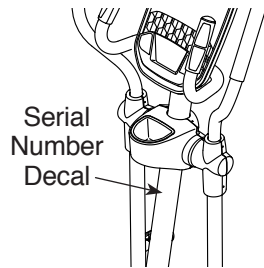

USER'S MANUAL

CUSTOMER SERVICE

UNITED KINGDOM

Call: 0330 123 1045

From Ireland: 053 92 36102

Website: iconsupport.eu

E-mail: csuk@iconeurope.com

Write:

ICON Health & Fitness, Ltd.

Unit 4, Westgate Court

Silkwood Park

OSSETT

WF5 9TT

UNITED KINGDOM

AUSTRALIA

Call: 1800 993 770

E-mail: australiacc@iconfitness.com

Write:

ICON Health & Fitness

PO Box 635

WINSTON HILLS NSW 2153

AUSTRALIA

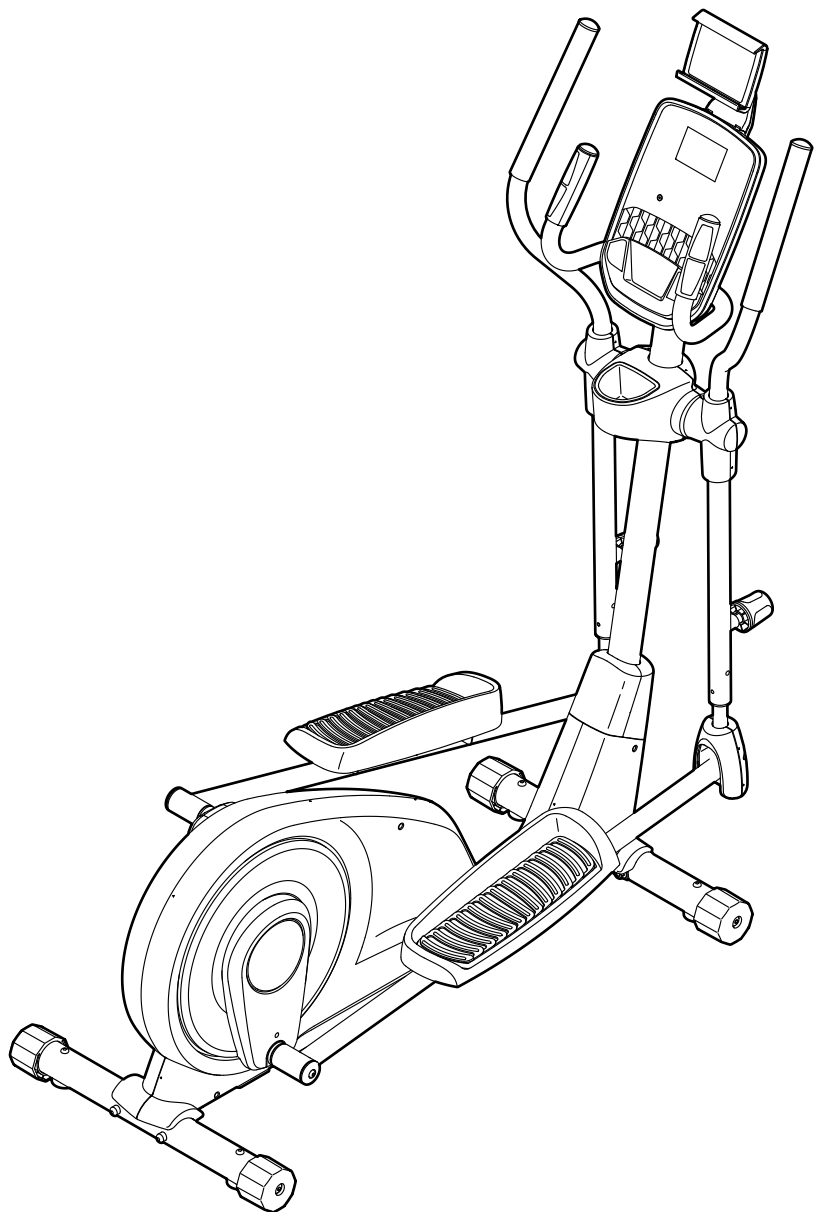

CAUTION

Read all precautions and instructions in this manual before using this equipment. Keep this manual for future reference.

iconeurope.com

TABLE OF CONTENTS

WARNING DECAL PLACEMENT 2

IMPORTANT PRECAUTIONS..... 3

BEFORE YOU BEGIN..... 4

PART IDENTIFICATION CHART..... 5

ASSEMBLY..... 6

HOW TO USE THE ELLIPTICAL 14

MAINTENANCE AND TROUBLESHOOTING..... 22

EXERCISE GUIDELINES 24

PART LIST 25

EXPLODED DRAWING..... 26

ORDERING REPLACEMENT PARTS..... Back Cover

RECYCLING INFORMATION Back Cover

WARNING DECAL PLACEMENT

This drawing shows the location(s) of the warning decal(s). **If a decal is missing or illegible, see the front cover of this manual and request a free replacement decal. Apply the decal in the location shown.** Note: The decal(s) may not be shown at actual size.

WARNING

- Misuse of this machine may result in serious injury.
- Read user's manual prior to use and follow all warnings and instructions.
- Do not allow children on or around machine.
- Pedals continue to spin when you stop pedaling.
- Spinning pedals can cause injury.
- Reduce pedal speed in a controlled manner.
- User weight must not exceed 275 lbs/125kg.
- This product should always be used on a level surface.
- This product is not intended for therapeutic use.
- Replace label if damaged, illegible, or removed.



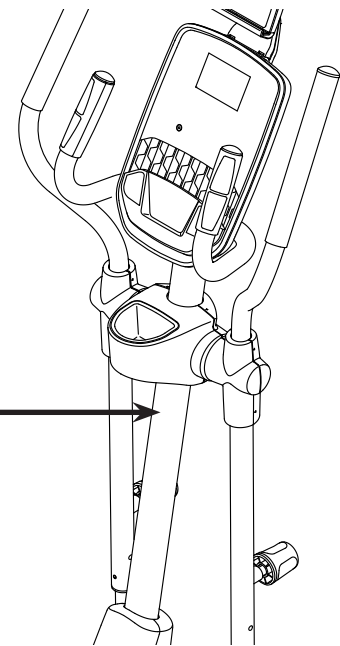

NORDICTRACK and IFIT are registered trademarks of ICON Health & Fitness, Inc. App Store is a trademark of Apple Inc., registered in the U.S. and other countries. Android and Google Play are trademarks of Google LLC. The Bluetooth® word mark and logos are registered trademarks of Bluetooth SIG, Inc. and are used under license. IOS is a trademark or registered trademark of Cisco in the U.S. and other countries and is used under license.



IMPORTANT PRECAUTIONS

⚠ WARNING: To reduce the risk of serious injury, read all important precautions and instructions in this manual and all warnings on your elliptical before using your elliptical. ICON assumes no responsibility for personal injury or property damage sustained by or through the use of this product.

1. It is the responsibility of the owner to ensure that all users of the elliptical are adequately informed of all precautions.
2. Before beginning any exercise program, consult your physician. This is especially important for persons over age 35 or persons with pre-existing health problems.
3. The elliptical is not intended for use by persons with reduced physical, sensory, or mental capabilities or lack of experience and knowledge, unless they are given supervision or instruction about use of the elliptical by someone responsible for their safety.
4. Use the elliptical only as described in this manual.
5. The elliptical is intended for home use only. Do not use the elliptical in a commercial, rental, or institutional setting.
6. Keep the elliptical indoors, away from moisture and dust. Do not put the elliptical in a garage or covered patio, or near water.
7. Place the elliptical on a level surface, with at least 3 ft. (0.9 m) of clearance in the front and rear of the elliptical and 2 ft. (0.6 m) on each side. To protect the floor or carpet from damage, place a mat under the elliptical.
8. Inspect and properly tighten all parts each time the elliptical is used. Replace any worn parts immediately.
9. Keep children under age 13 and pets away from the elliptical at all times.
10. The elliptical should not be used by persons weighing more than 275 lbs. (125 kg).
11. Wear appropriate clothes while exercising; do not wear loose clothes that could become caught on the elliptical. Always wear athletic shoes for foot protection while exercising.
12. Hold the handlebars or the upper body arms when mounting, dismounting, or using the elliptical.
13. The heart rate monitor is not a medical device. Various factors may affect the accuracy of heart rate readings. The heart rate monitor is intended only as an exercise aid in determining heart rate trends in general.
14. The elliptical does not have a freewheel; the pedals will continue to move until the flywheel stops. Reduce your pedaling speed in a controlled way.
15. Keep your back straight while using the elliptical; do not arch your back.
16. Over exercising may result in serious injury or death. If you feel faint, if you become short of breath, or if you experience pain while exercising, stop immediately and cool down.

BEFORE YOU BEGIN

Thank you for purchasing the NORDICTRACK® SE 3I elliptical. The SE 3I elliptical provides an array of features designed to make your workouts at home more effective and enjoyable.

For your benefit, read this manual carefully before you use the elliptical. If you have questions after reading this manual, please see the front cover of this

manual. To help us assist you, note the product model number and serial number before contacting us. The model number and the location of the serial number decal are shown on the front cover of this manual.

Before reading further, please familiarize yourself with the parts that are labeled in the drawing below.

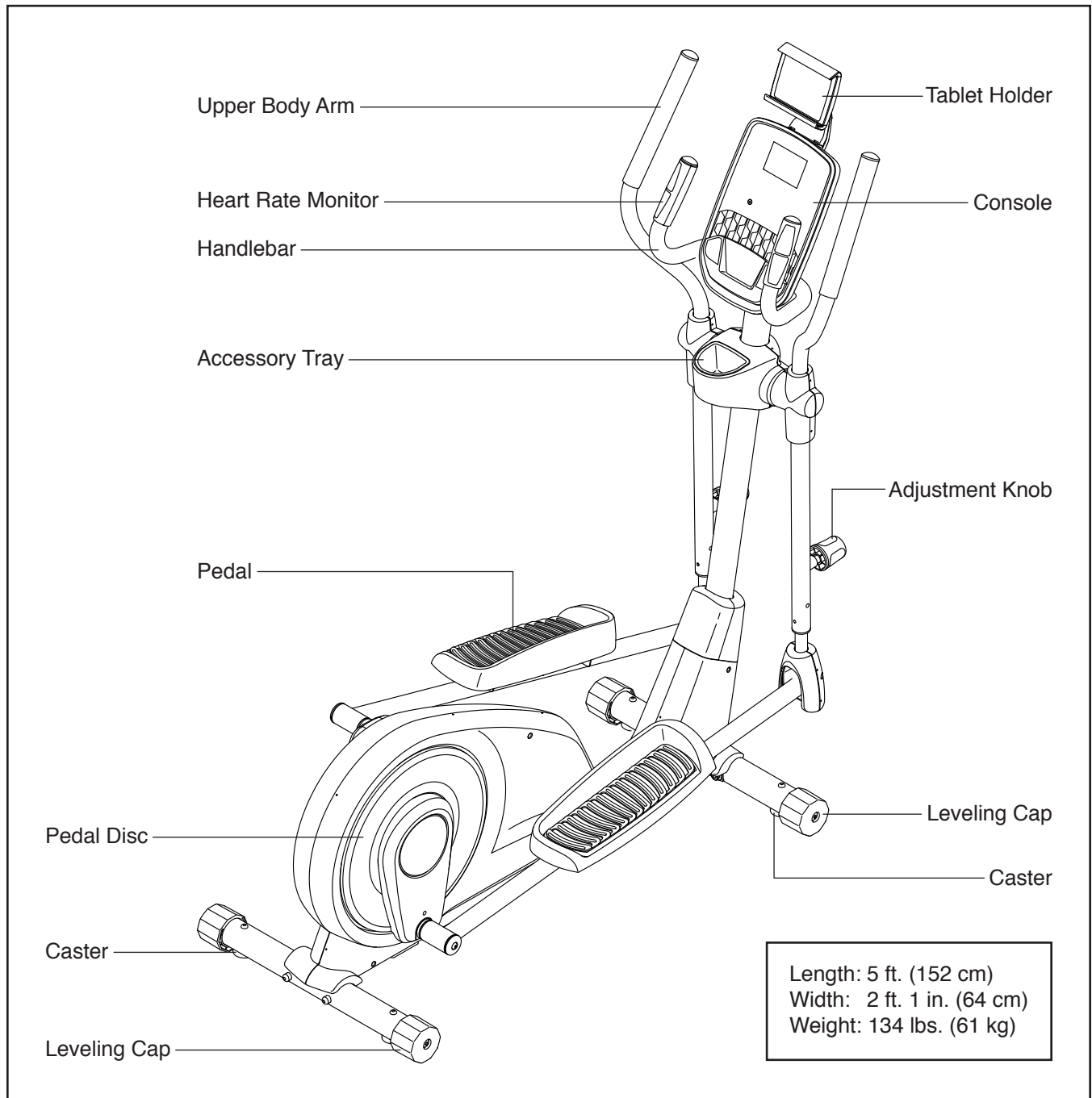

PART IDENTIFICATION CHART

Use the drawings below to identify the small parts needed for assembly. The number in parentheses below each drawing is the key number of the part, from the PART LIST near the end of this manual. The number following the key number is the quantity needed for assembly. **Note: If a part is not in the hardware kit, check to see if it has been preassembled. Extra parts may be included.**

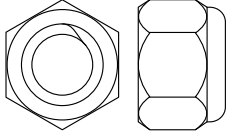
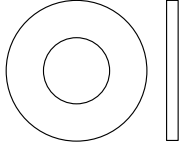
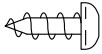
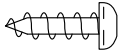
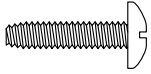
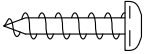
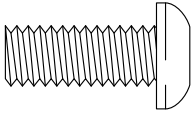
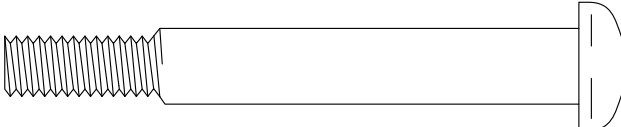
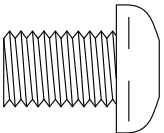
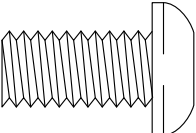
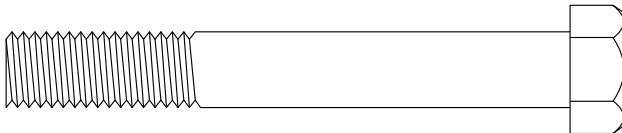
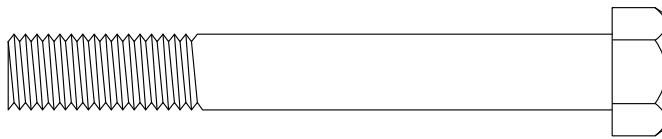
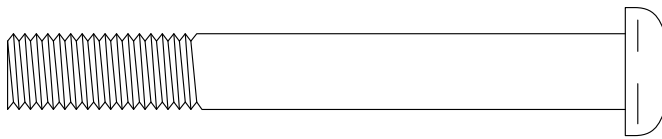
			
	M10 Locknut (62)-2	M8 Washer (83)-2	
			
M4 x 10mm Screw (95)-4	M4 x 12mm Screw (77)-4	M4 x 16mm Machine Screw (94)-4	M4 x 16mm Screw (78)-15
			
M8 x 20mm Screw (84)-2	M8 x 76mm Shoulder Screw (63)-2		
			
M10 x 15mm Screw (67)-6	M10 x 20mm Screw (79)-3	M10 x 75mm Bolt (61)-1	
			
M10 x 80mm Bolt (86)-1			
			
M10 x 82mm Screw (70)-4			

ASSEMBLY

- Assembly requires two persons.
- Place all parts in a cleared area and remove the packing materials. Do not dispose of the packing materials until you finish all assembly steps.
- Left parts are marked “L” or “Left” and right parts are marked “R” or “Right.”
- To identify small parts, see page 5.

- In addition to the included tool(s), assembly requires the following tool(s):

one Phillips screwdriver 

two adjustable wrenches 

one rubber mallet 

Assembly may be easier if you have a set of wrenches. To avoid damaging parts, do not use power tools.

1. **To register your product and activate your warranty in the UK**, go to iconsupport.eu. If you do not have internet access, call Customer Service (see the front cover of this manual).

To register your product and activate your warranty in Australia, email or post the following information to the email address or postal address on the front cover of this manual.

- your receipt (make sure to keep a copy)
- your name, address, and telephone number
- the model number, serial number, and name of your product (see the front cover of this manual)

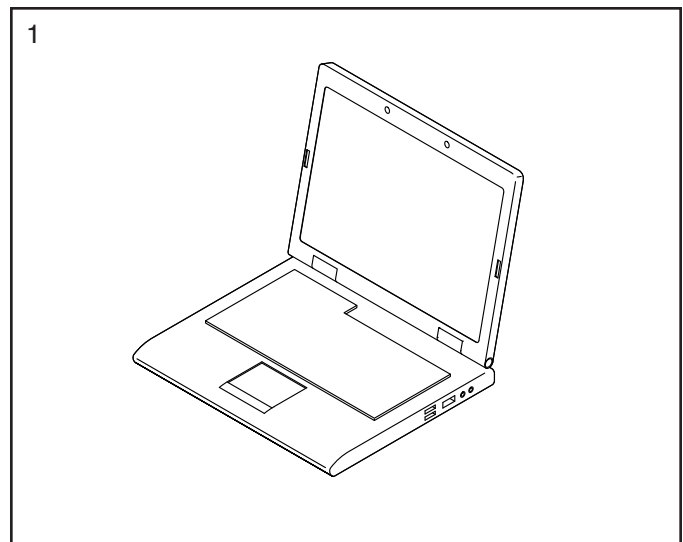

2. If there is a shipping tube (not shown) attached to the Frame (1), remove the screws (not shown) and then remove the shipping tube. Discard the screws and the shipping tube.

With the help of a second person, place some of the packing materials (not shown) under the rear of the Frame (1).

Attach a Stabilizer (3) to the Frame (1) with two M10 x 82mm Screws (70).

Then, remove the packing materials from under the rear of the Frame (1).

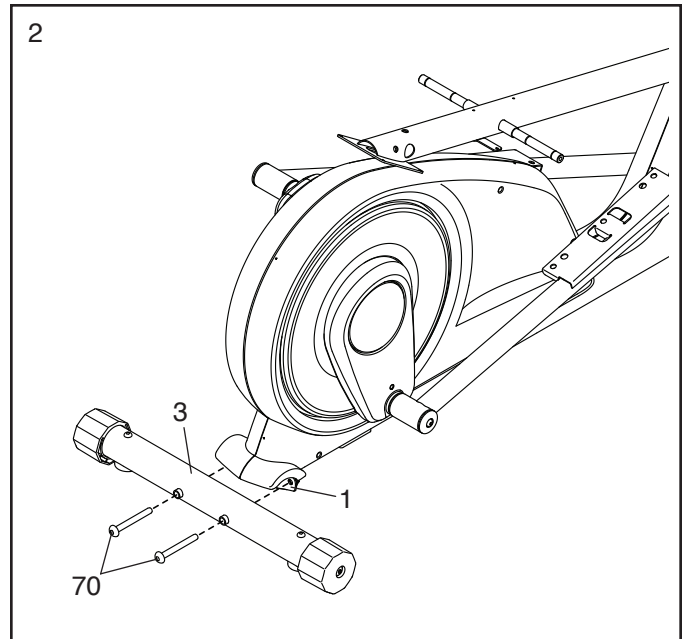

3. If there is a shipping tube (not shown) attached to the Frame (1), remove the screws (not shown) and then remove the shipping tube. Discard the screws and the shipping tube.

With the help of a second person, place some of the packing materials (not shown) under the front of the Frame (1).

Tip: Make sure to lift the Pedal Arms (16, 17) above the Stabilizer (3) before you attach it. Attach the other Stabilizer to the Frame (1) with two M10 x 82mm Screws (70).

Then, remove the packing materials from under the front of the Frame (1).

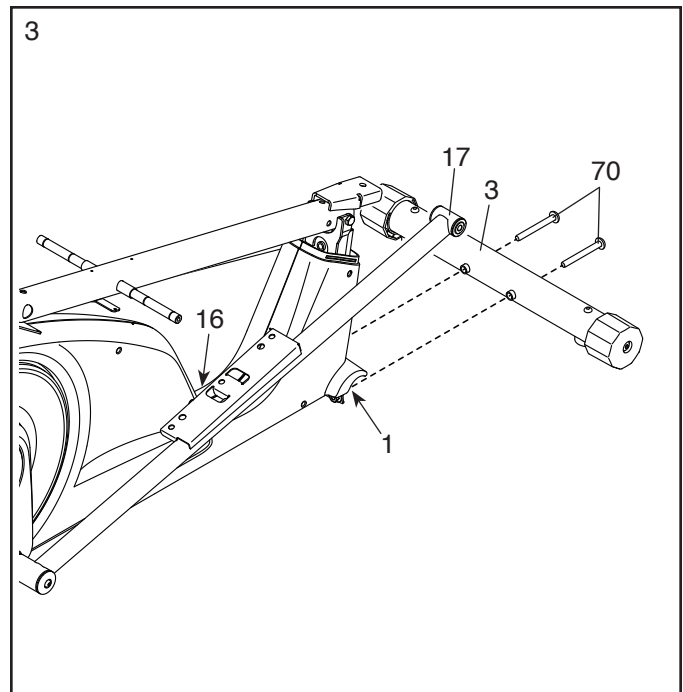

4. With the help of a second person, raise the Upright (2) to the vertical position.

Secure the Upright (2) to the Frame (1) with an M10 x 75mm Bolt (61), an M10 x 80mm Bolt (86), and two M10 Locknuts (62); **insert both Bolts, and then tighten the Locknuts.**

Then, tighten the indicated M10 Locknut (A).

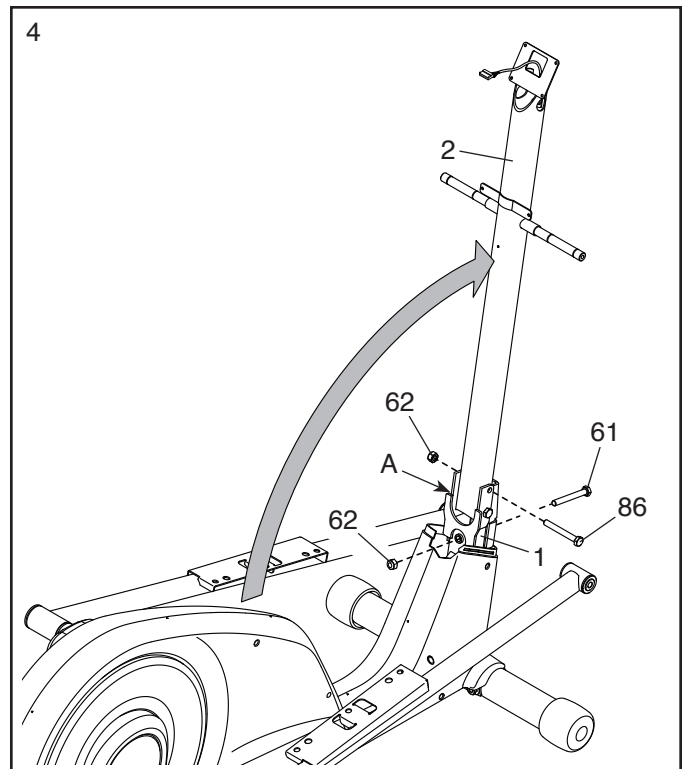

5. Identify the Rear Shield Cover (27) and the Front Shield Cover (28), and orient them as shown.

Press the Rear and Front Shield Covers (27, 28) together around the Upright (2), slide them downward, and press them onto the Left and Right Shields (30, 31).

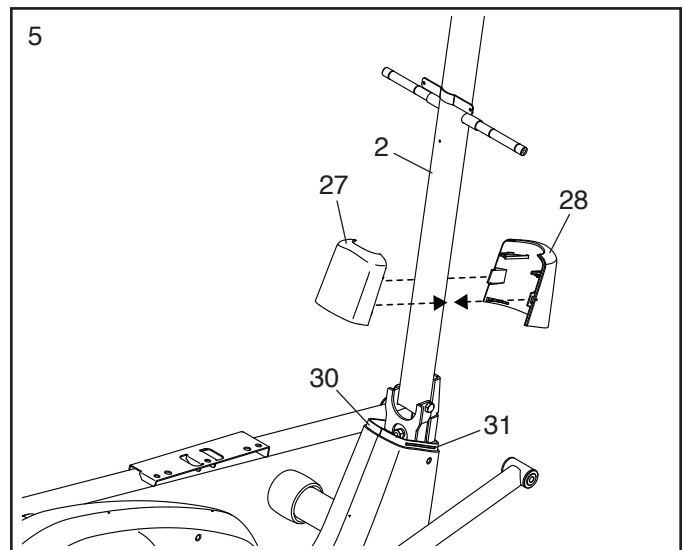

6. Attach the Rear Upright Cover (25) to the Upright (2) with three M4 x 16mm Screws (78); **start all the Screws, and then tighten them.**

Then, insert the Accessory Tray (24) into the Rear Upright Cover (25).

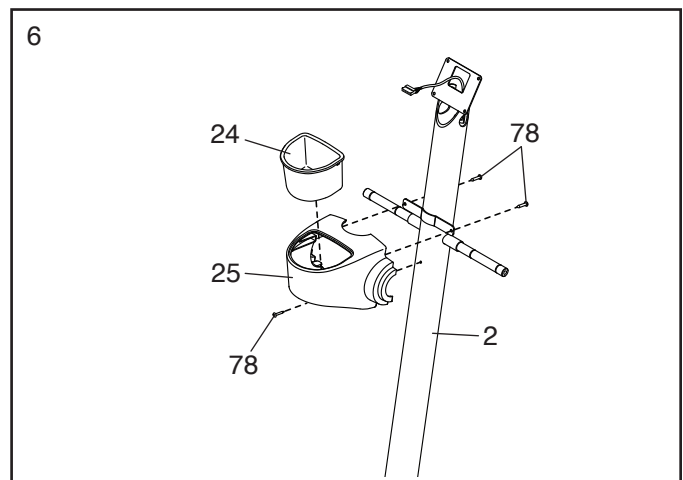

7. Orient the Front Upright Cover (26) so that the word "UP" is at the top.

Attach the Front Upright Cover (26) to the Rear Upright Cover (25) with two M4 x 16mm Screws (78).

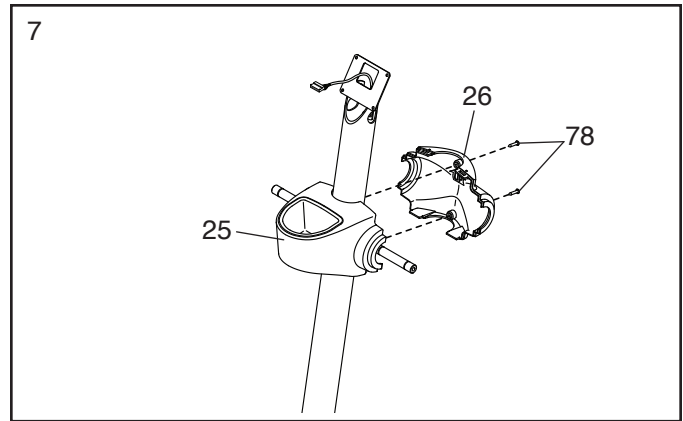

8. Using a plastic bag to keep your fingers clean, apply a generous amount of the included grease to the axles on the Upright (2).

Next, slide a Pivot Spacer (55) onto the right axle on the Upright (2). Then, identify the Right Upper Body Arm (10), orient it as shown, and slide it onto the right axle on the Upright.

Attach the Right Upper Body Arm (10) with an M8 x 20mm Screw (84) and an M8 Washer (83).

Repeat this step on the other side of the elliptical.

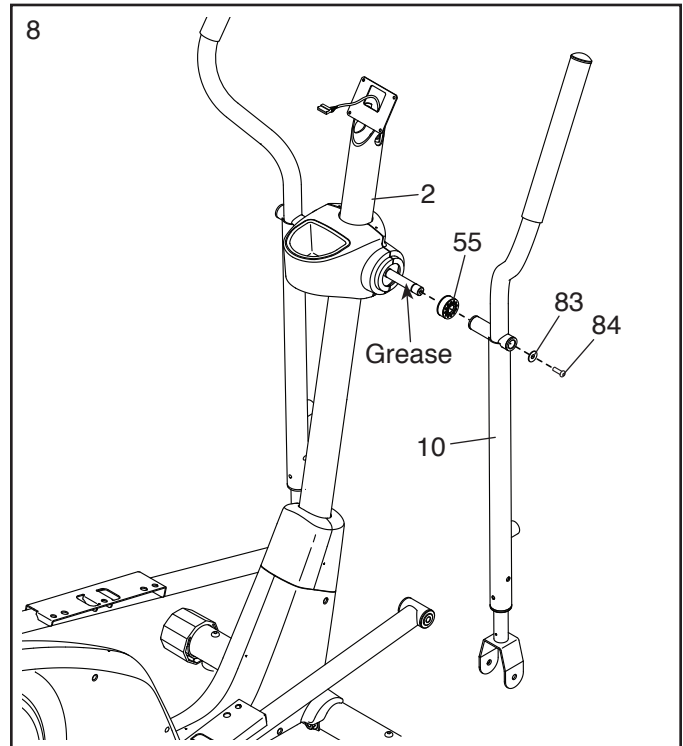

9. Identify the Right Rear and Front Arm Covers (20, 21), and orient them as shown.

Press the Right Rear and Front Arm Covers (20, 21) together around the Right Upper Body Arm (10), and attach them with two M4 x 16mm Screws (78). **Tip: Attach the lower Screw first, and then attach the upper Screw.**

Repeat this step on the other side of the elliptical.

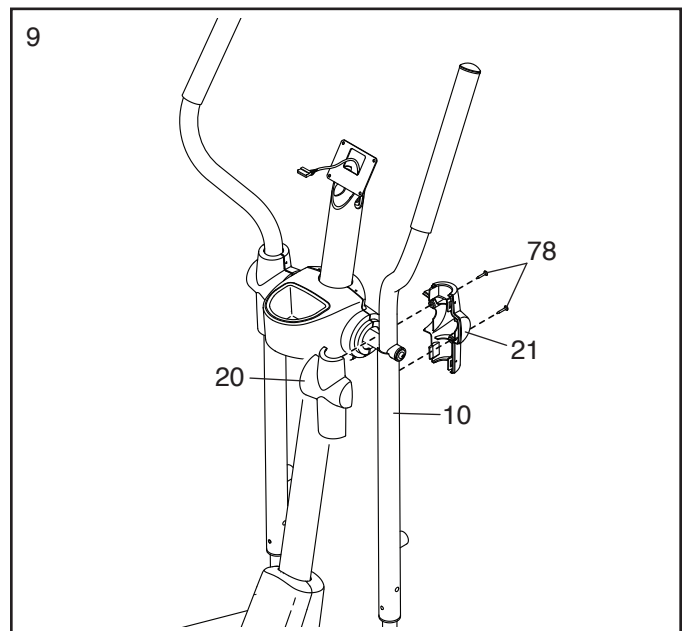

10. Identify the Right Pedal (7), and orient it as shown.

Attach the Right Pedal (7) to the Right Pedal Arm (17) with three M10 x 15mm Screws (67); **start all the Screws, and then tighten them. Make sure to use the center hole and the two outer holes to attach the Right Pedal.**

Repeat this step on the other side of the elliptical.

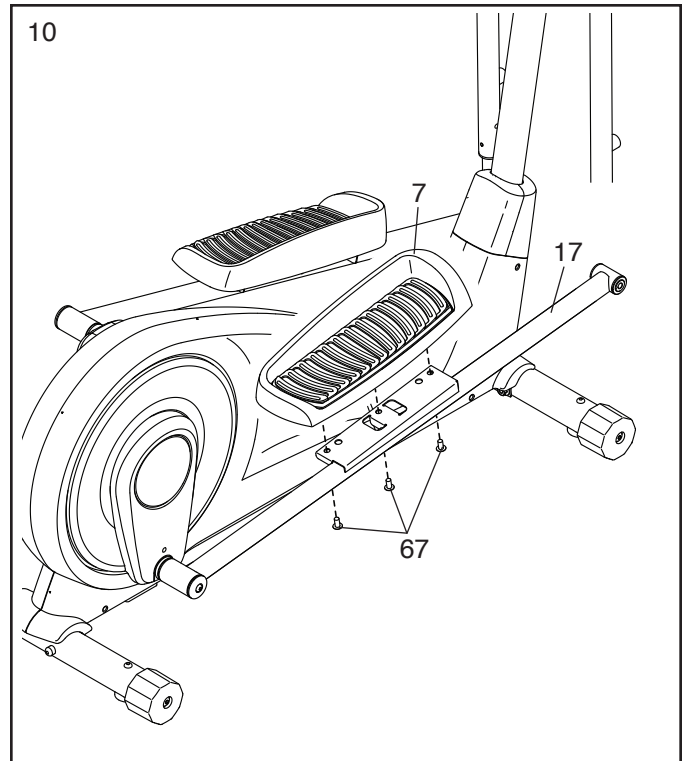

11. Apply a small amount of grease to an M8 x 76mm Shoulder Screw (63).

Attach the front end of the Right Pedal Arm (17) inside the bracket on the right Upper Body Leg (13) with the M8 x 76mm Shoulder Screw (63).

Next, use an adjustable wrench to tighten a Knob (15) into the Right Upper Body Arm (10). Then, pull the Knob, slide the Upper Body Leg (13) farther into the Right Upper Body Arm, and release the Knob into one of the three adjustment holes in the Upper Body Leg.

Repeat this step on the other side of the elliptical.

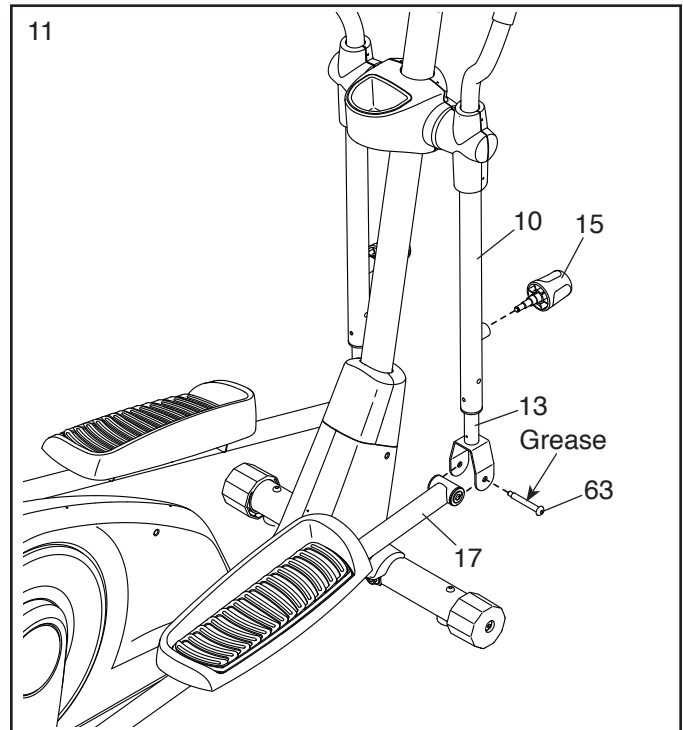

12. Identify the Rear and Front Leg Covers (38, 39), and orient them as shown.

Press the Rear and Front Leg Covers (38, 39) together around the right Upper Body Leg (13), and attach them with three M4 x 16mm Screws (78); **start the center Screw first, and then start the other two Screws. Then, tighten all the Screws.**

Repeat this step on the other side of the elliptical.

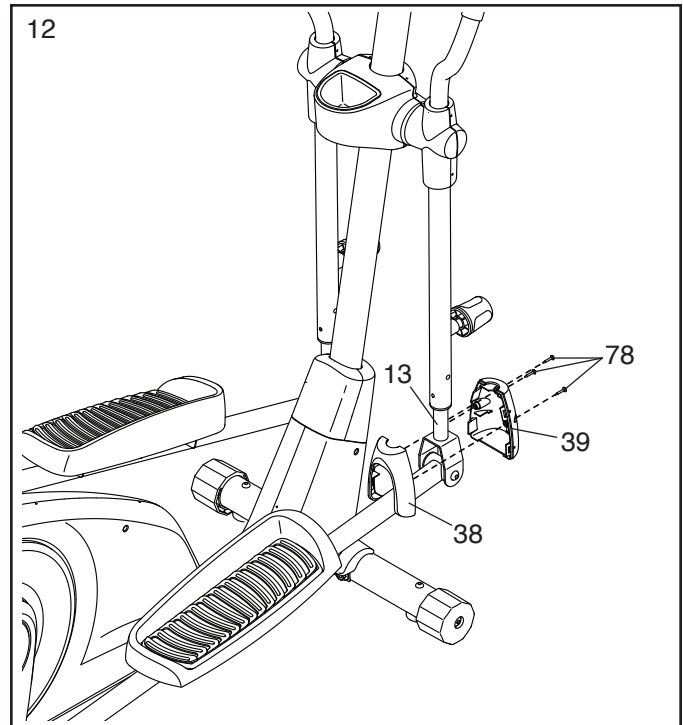

13. Orient the Console Plate (92) as shown and hold it near the Upright (2).

Next, insert the Main Wire (89) in the Upright (2) through the Console Plate (92).

Tip: Avoid pinching the Main Wire (89). Attach the Console Plate (92) to the Upright (2) with four M4 x 10mm Screws (95); **start all the Screws, and then tighten them.**

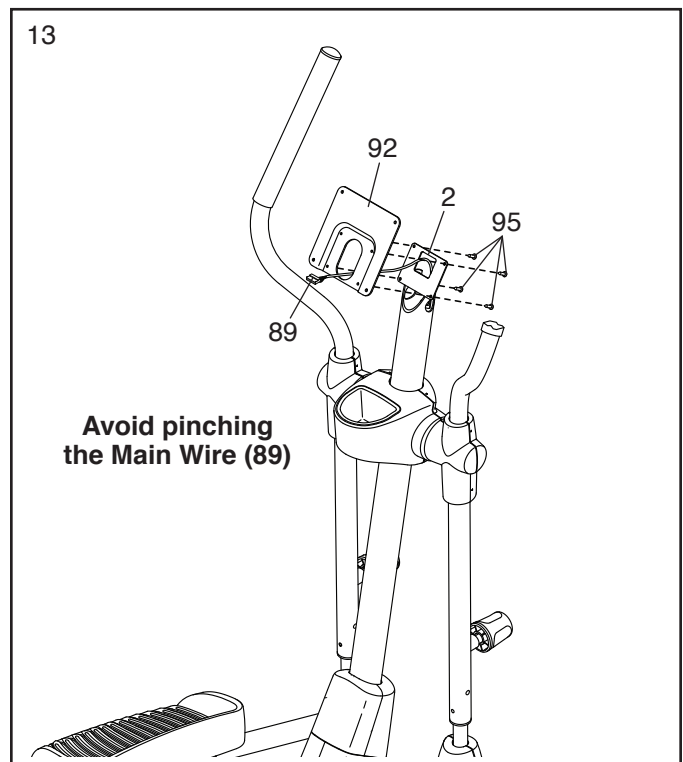

14. Have a second person hold the Handlebar (22) in place around the Upright (2).

Next, locate the Pulse Wires (23) inside the left and right sides of the Handlebar (22), and carefully pull them through the Upright (2) as shown.

Tip: Avoid pinching the Pulse Wires (23). Attach the Handlebar (22) to the Upright (2) with three M10 x 20mm Screws (79); **start all the Screws, and then tighten them.**

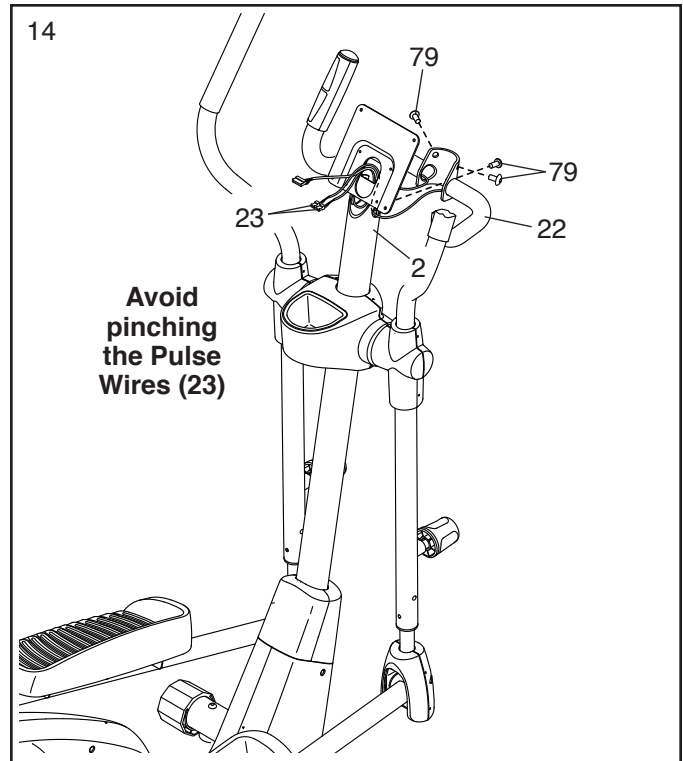

15. Untie and discard the wire tie attached to the Main Wire (89).

While a second person holds the Console (5) near the Upright (2), plug the Main Wire (89) and the Pulse Wires (23) into the receptacles on the Console.

The connectors on the Main Wire (89) and the Pulse Wires (23) should slide easily into the receptacles and snap into place. If a connector does not slide easily into a receptacle, turn the connector and try again. **If you do not connect the connectors properly, the Console (5) may become damaged when you use the elliptical.**

Insert the excess wire into the Upright (2).

Tip: Avoid pinching the wires. Attach the Console (5) to the Upright (2) with four M4 x 12mm Screws (77); **start all the Screws, and then tighten them.**

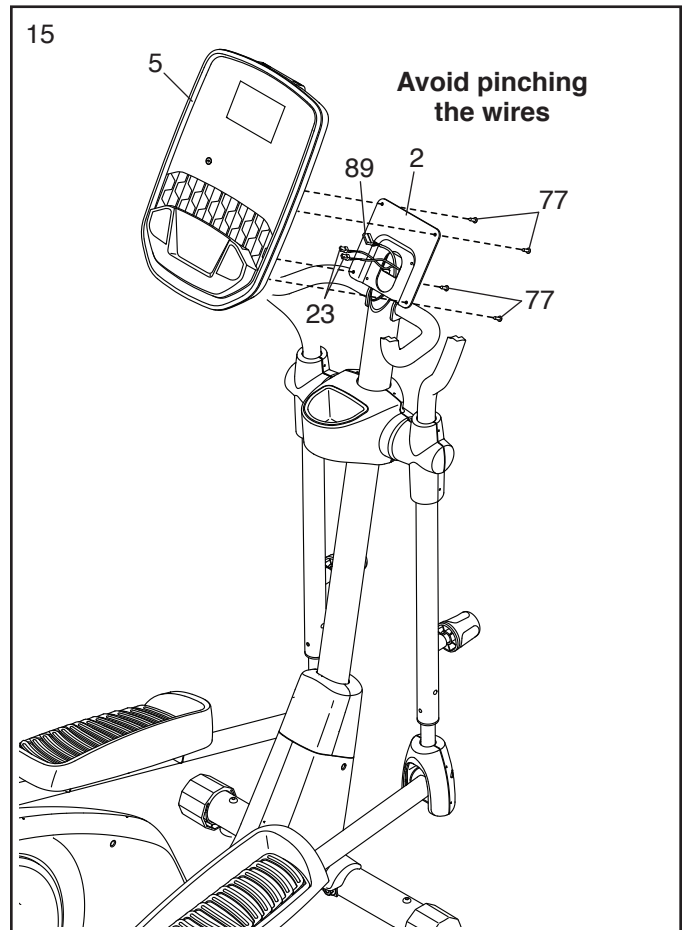

16. Attach the Tablet Holder (93) to the Console (5) with four M4 x 16mm Machine Screws (94); **start all the Machine Screws, and then tighten them.**

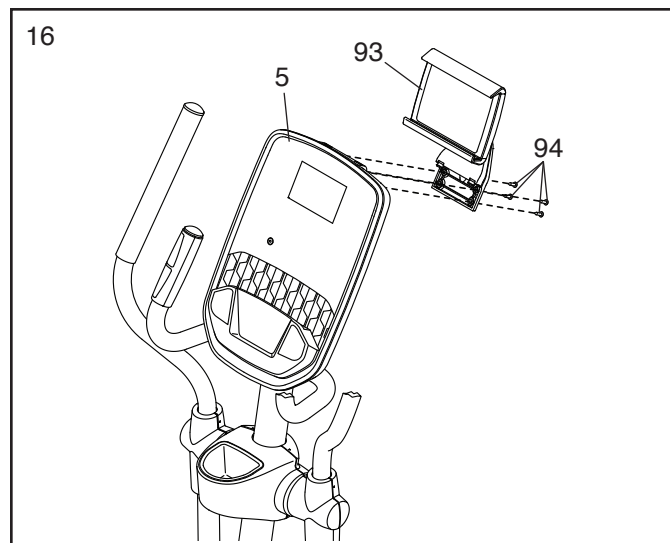

17. Plug the Power Adapter (90) into the receptacle on the frame of the elliptical.

Note: To plug the Power Adapter (90) into an outlet, see HOW TO PLUG IN THE POWER ADAPTER on page 14.

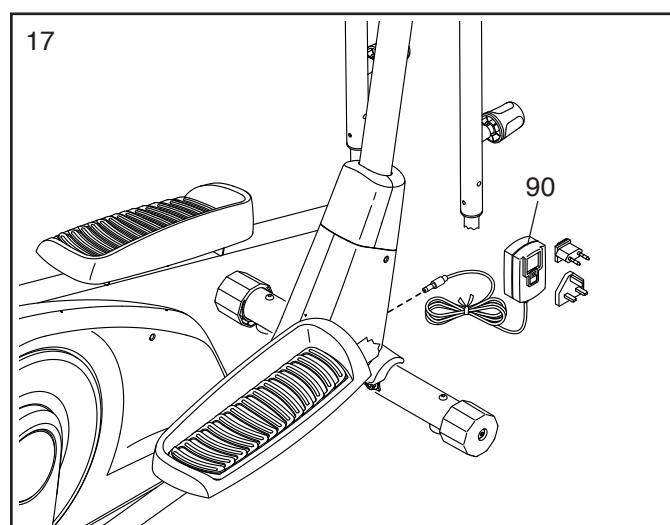

18. **Make sure that all parts are properly tightened.** Place a mat beneath the elliptical to protect the floor. Extra parts may be included.

HOW TO USE THE ELLIPTICAL

HOW TO PLUG IN THE POWER ADAPTER

IMPORTANT: If the elliptical has been exposed to cold temperatures, allow it to warm to room temperature before you plug in the power adapter (A). If you do not do this, you may damage the console displays or other electronic components.

Plug the power adapter (A) into the receptacle on the frame of the elliptical. Then, plug the power adapter into an appropriate outlet that is properly installed in accordance with all local codes and ordinances.

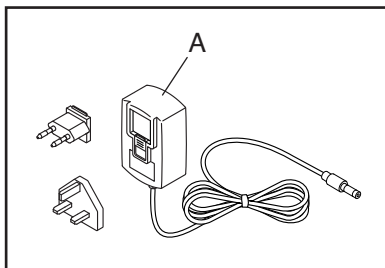

HOW TO LEVEL THE ELLIPTICAL

If the elliptical rocks slightly on your floor during use, turn the leveling caps (B) on the stabilizers until the rocking motion is eliminated.

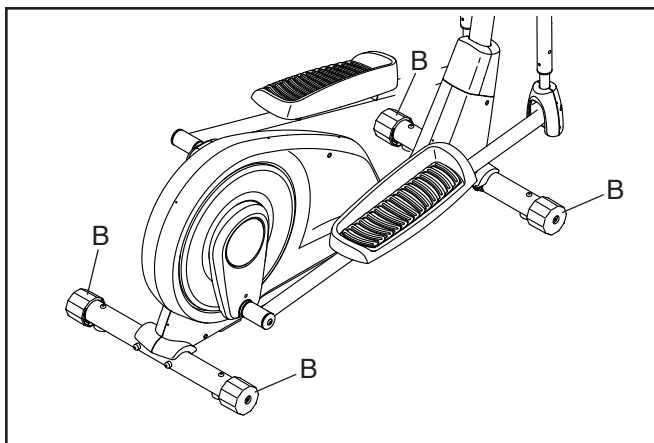

HOW TO VARY THE MOTION OF THE PEDALS

To vary the motion of the pedals, first pull one of the knobs (C), slide the upper body leg (D) farther into or out of the upper body arm (E), and then release the knob into one of the three adjustment holes in the upper body leg. **Then, repeat this procedure on the other side of the elliptical.**

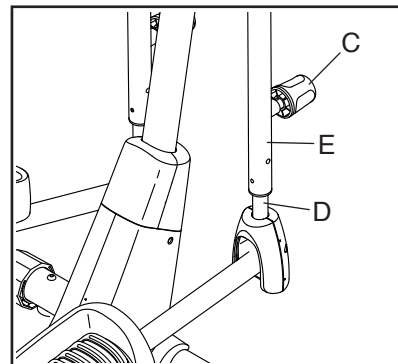

HOW TO USE THE TABLET HOLDER

IMPORTANT: The tablet holder (F) is designed for use with most full-size tablets. Do not place any other electronic device or object in the tablet holder. Do not set anything on top of the tablet holder.

To insert a tablet into the tablet holder (F), slide the tablet holder upward, set the tablet in the tray, and then pull the tablet holder downward over the top edge of the tablet. **Make sure that the tablet is firmly secured in the tablet holder.** If applicable to your tablet holder model, rotate and/or pivot the tablet holder to the desired position. Reverse these actions to remove the tablet from the tablet holder.

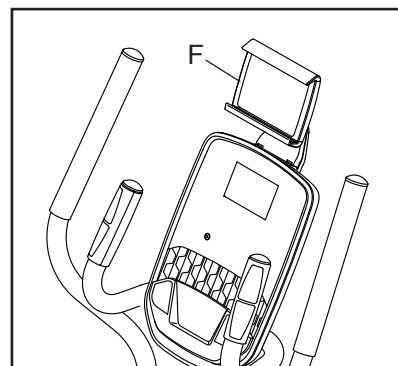

HOW TO MOVE THE ELLIPTICAL

Turn each leveling cap (B) to the transport position; in the transport position, the caster beside each leveling cap will touch the floor. Next, hold the upright (G) and carefully move the elliptical to the desired location. Then, turn each leveling cap until the casters are not touching the floor and the elliptical is level on your floor.

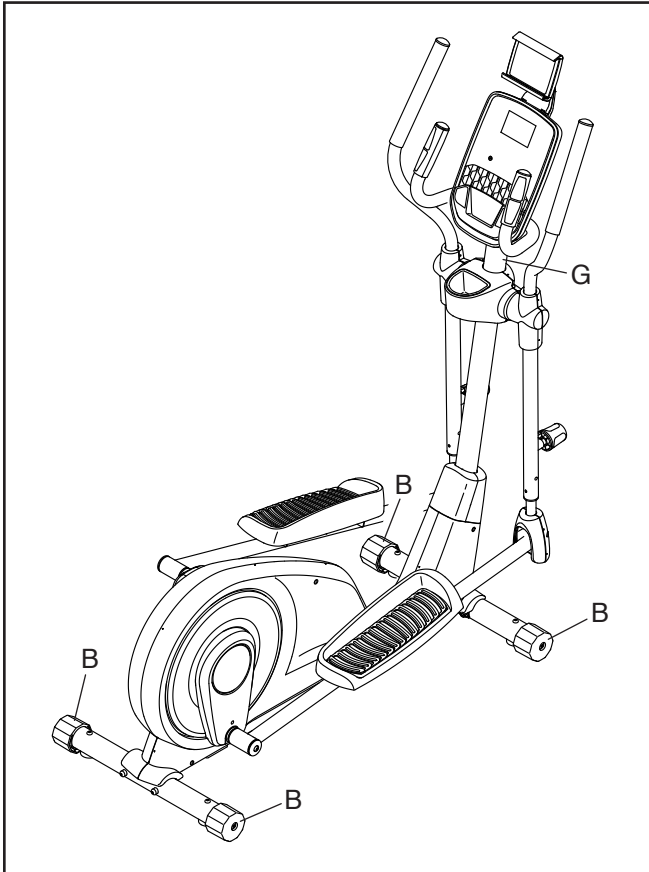

HOW TO EXERCISE ON THE ELLIPTICAL

To mount the elliptical, hold the handlebars (H) or the upper body arms (I) and step onto the pedal (J) that is in the lowest position. Then, step onto the other pedal.

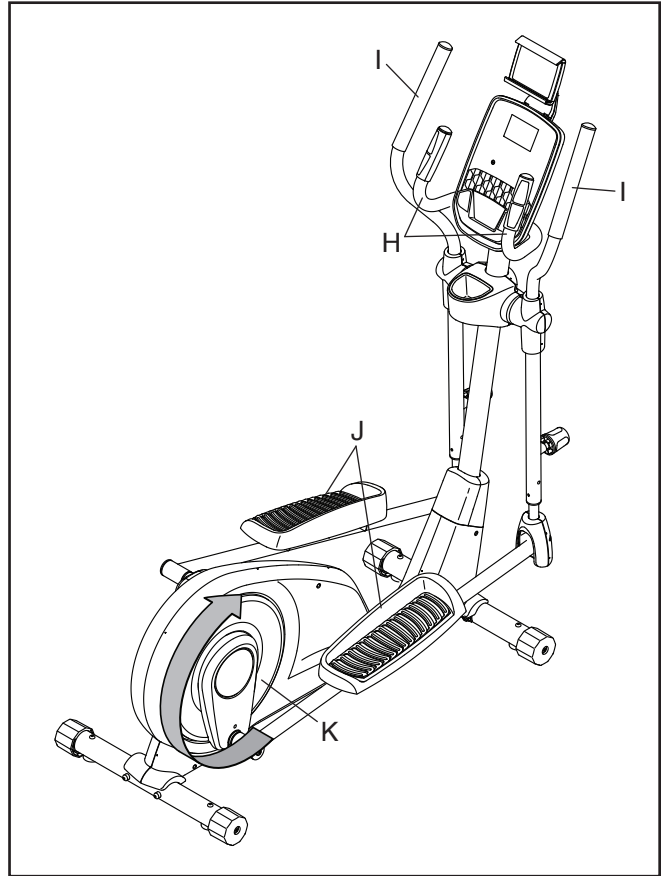

Push the pedals (J) until they begin to move with a continuous motion. **Note: The pedal discs (K) can turn in either direction. It is recommended that you move the pedal discs in the direction shown by the arrow; however, for variety, you can turn the pedal discs in the opposite direction.**

To dismount the elliptical, wait until the pedals (J) come to a complete stop. **Note: The elliptical does not have a freewheel; the pedals will continue to move until the flywheel stops.** When the pedals are stationary, step off the highest pedal first. Then, step off the lowest pedal.

CONSOLE DIAGRAM

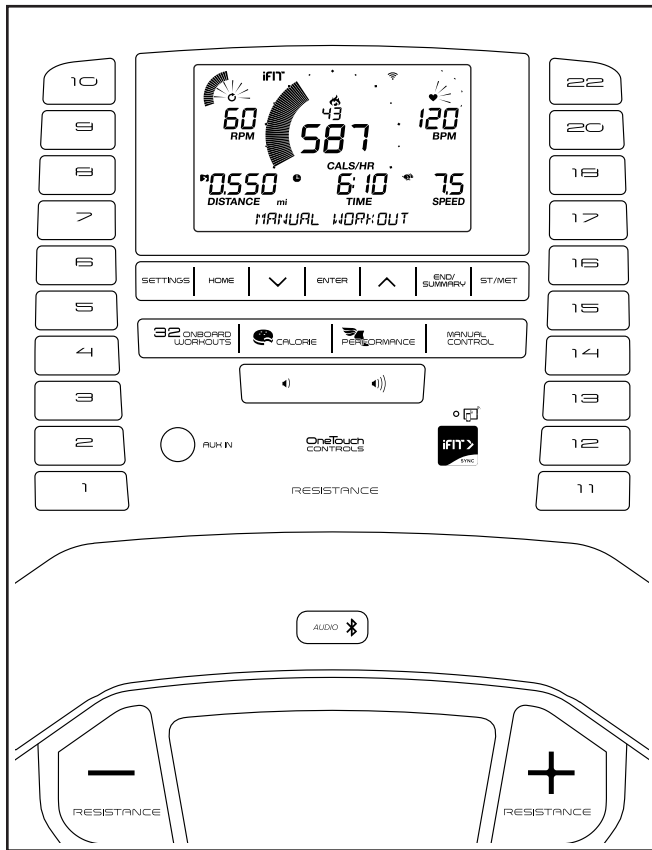

FEATURES OF THE CONSOLE

The advanced console offers an array of features designed to make your workouts more effective and enjoyable.

When you use the manual mode of the console, you can change the resistance of the pedals with the touch of a button.

As you exercise, the console will provide continuous exercise feedback. You can even measure your heart rate using a compatible heart rate monitor. **See page 21 for information about purchasing an optional chest heart rate monitor.**

You can also connect your tablet to the console and use the iFit®—Smart Cardio Equipment app to record and track your workout information.

The console also offers a selection of onboard workouts. Each workout automatically changes the resistance of the pedals as it guides you through an effective workout.

You can even listen to your favorite workout music or audio books with the console sound system while you exercise.

To use the manual mode, see this page. **To use an onboard workout**, see page 18. **To connect your tablet to the console**, see page 19. **To connect your heart rate monitor to the console**, see page 20. **To use the sound system**, see page 20. **To connect to the sound system with Bluetooth**, see page 20. **To change console settings**, see page 21.

Note: If there is a sheet of plastic on the display, remove the plastic.

Note: The console can display speed and distance in either standard units or metric units. To change the unit of measurement, press the St/Met button repeatedly. For simplicity, all instructions in this section refer to standard units.

HOW TO USE THE MANUAL MODE

1. Begin pedaling or press any button on the console to turn on the console.

When you turn on the console, the display will turn on. The console will then be ready for use.

2. Select the manual mode.

Press the Manual Control button to select the manual mode.

3. Change the resistance of the pedals as desired.

As you pedal, change the resistance of the pedals by pressing the Resistance increase and decrease buttons or by pressing one of the numbered Resistance buttons.

Note: After you press a button, it will take a moment for the pedals to reach the selected resistance level.

4. Follow your progress with the displays.

The display can show the following workout information:

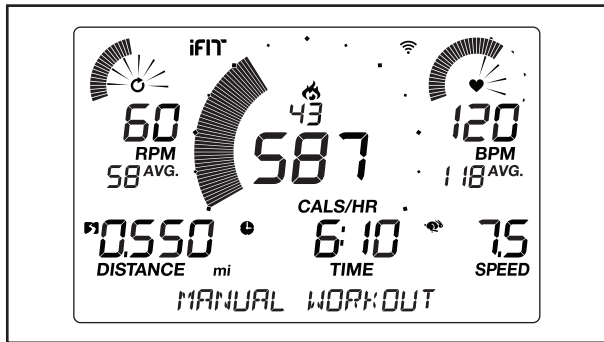

Calories (flame icon)—This display will show the approximate number of calories you have burned. When some onboard workouts are selected, this display will show the number of calories remaining to be burned for the workout.

Calories per Hour (Cals/Hr)—This display will show the approximate number of calories you are burning per hour.

Distance—This display will show the distance that you have pedaled in miles (mi) or kilometers (km). To change the unit of measurement, press the St/Met button repeatedly.

Pulse (BPM)—This display will show your heart rate in beats per minute (bpm) when you use a heart rate monitor (see step 5).

Pulse Average (BPM AVG)—This display will show your average heart rate in beats per minute (bpm) when you use a heart rate monitor (see step 5).

Resistance—This display will show the resistance level of the pedals for a few seconds each time the resistance level changes.

RPM—This display will show your pedaling speed in revolutions per minute (rpm).

RPM Average (RPM AVG)—This display will show your average pedaling speed in revolutions per minute (rpm).

Speed—This display will show your pedaling speed in miles per hour or kilometers per hour. To change the unit of measurement, press the St/Met button repeatedly.

Time—When the manual mode is selected, this display will show the elapsed time. When some onboard workouts are selected, this display will show the time remaining in the workout.

Watts—This display will show your approximate power output in watts.

Average Watts (AVG)—This display will show your approximate average power output in watts for the workout.

Scan Mode and Priority

Mode—The calories and watts displays will appear in an alternating cycle (scan mode).



To select either the calories or the watts display for continuous display (priority mode), press the increase or decrease button next to the Enter button repeatedly until the desired display appears. To return to the scan mode, press the increase button repeatedly until the word SCAN appears.

Press the Home button to exit the workout and return to the main menu. If necessary, press the Home button again.

Press the End/Summary button to end the workout and view a workout summary. The workout summary will appear in the displays for several seconds.

Change the volume level of the console by pressing the volume increase and decrease buttons.

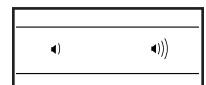

Note: The console can show speed and distance in standard or metric units of measurement. To change the unit of measurement, press the St/Met button.

5. Measure your heart rate if desired.

You can measure your heart rate using either the handgrip heart rate monitor or an optional chest heart rate monitor (see page 21 for information about the optional chest heart rate monitor). Note: The console is compatible with Bluetooth® Smart heart rate monitors.

Note: If you use both heart rate monitors at the same time, the Bluetooth Smart heart rate monitor will have priority.

If there are sheets of plastic on the metal contacts (A) on the handgrip heart rate monitor, remove the plastic. To measure your heart rate, hold the handgrip heart rate monitor with your palms resting against the contacts. Avoid moving your hands or gripping the contacts tightly.

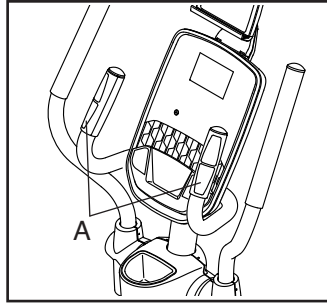

6. When you are finished exercising, the console will turn off automatically.

If the pedals do not move for several seconds, the console will pause, and the time will flash in the display. To resume your workout, simply resume pedaling.

If the pedals do not move for several minutes and the buttons are not pressed, the console will turn off and the display will be reset.

Note: The console features a display demo mode, designed to be used if the elliptical is displayed in a store. When the demo mode is turned on, the console will show a preset presentation. To turn off the demo mode, see HOW TO CHANGE CONSOLE SETTINGS on page 21.

HOW TO USE AN ONBOARD WORKOUT

1. Begin pedaling or press any button on the console to turn on the console.

When you turn on the console, the display will turn on. The console will then be ready for use.

2. Select an onboard workout.

To select an onboard workout, press the Calorie button or the Performance button repeatedly until the desired workout appears in the display.

When you select an onboard workout, the display will show the name of the workout and the duration of the workout or the number of calories to be burned.

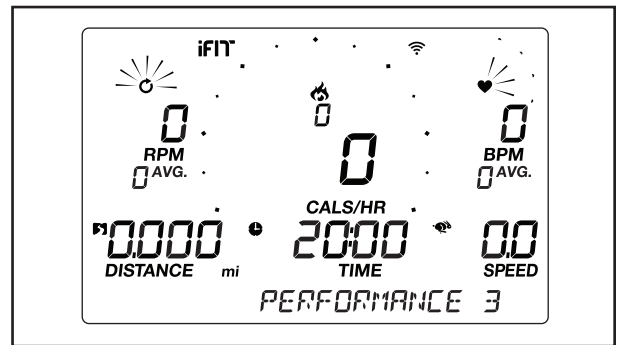

The maximum speed and the maximum resistance level for the workout will also appear in the display.

3. Begin pedaling to start the workout.

Each workout is divided into one-minute segments. One resistance level and one target speed are programmed for each segment. Note: The same resistance level and/or target speed may be programmed for consecutive segments.

If a different resistance level is programmed for the next segment of the workout, the resistance level will appear in the display for a few seconds to alert you. The resistance of the pedals will then change.

As you exercise, you will be prompted to keep your pedaling speed near the target speed for the current segment. **When the words GO FASTER appear in the display**, increase your pace. **When the words SLOW DOWN appear**, decrease your pace. **When the words IN RANGE TARGET appear**, maintain your current pace.

IMPORTANT: The target speed is intended only to provide motivation. Your actual pedaling speed may be slower than the target speed. Make sure to pedal at a speed that is comfortable for you.

If the resistance level for the current segment is too high or too low, you can manually override the setting by pressing the Resistance buttons. **IMPORTANT: When the current segment of the workout ends, the pedals will automatically adjust to the resistance level programmed for the next segment.**

The workout will continue in this way until the last segment ends. To pause the workout at any time, stop pedaling. The time will flash in the display. To resume the workout, simply resume pedaling.

To end the workout, press the End/Summary button. A summary of the workout will appear in the displays for several seconds.

4. Follow your progress with the displays.

See step 4 on page 17.

5. Measure your heart rate if desired.

See step 5 on page 18.

6. When you are finished exercising, the console will turn off automatically.

See step 6 on page 18.

HOW TO CONNECT YOUR TABLET TO THE CONSOLE

The console supports Bluetooth connections to tablets via the iFit–Smart Cardio Equipment app and to compatible heart rate monitors. Note: Other Bluetooth connections are not supported.

1. Download and install the iFit–Smart Cardio Equipment app on your tablet.

On your iOS® or Android™ tablet, open the App StoreSM or the Google Play™ store, search for the free iFit–Smart Cardio Equipment app, and then install the app on your tablet. **Make sure that the Bluetooth option is enabled on your tablet.**

Then, open the iFit–Smart Cardio Equipment app and follow the instructions to set up an iFit account and customize settings.

2. Connect your heart rate monitor to the console if desired.

If you are connecting both your heart rate monitor and your tablet to the console, **you must connect your heart rate monitor before you connect your tablet.** See HOW TO CONNECT YOUR HEART RATE MONITOR TO THE CONSOLE on page 20.

3. Connect your tablet to the console.

Press the iFit Sync button on the console; the console pairing number will appear in the display. Then, follow the instructions in the iFit–Smart Cardio Equipment app to connect your tablet to the console.

When a connection is established, the LED on the console will turn solid blue.

4. Record and track your workout information.

Follow the instructions in the iFit–Smart Cardio Equipment app to record and track your workout information.

5. Disconnect your tablet from the console if desired.

To disconnect your tablet from the console, first select the disconnect option in the iFit–Smart Cardio Equipment app. Then, press and hold the iFit Sync button on the console until the LED on the console turns solid green.

Note: All Bluetooth connections between the console and other devices (including any tablets, heart rate monitors, and so forth) will be disconnected.

HOW TO CONNECT YOUR HEART RATE MONITOR TO THE CONSOLE

The console is compatible with all Bluetooth Smart heart rate monitors.

To connect your Bluetooth Smart heart rate monitor to the console, press the iFit Sync button on the console; the console pairing number will appear in the display. When a connection is established, the LED on the console will flash red twice.

Note: If there is more than one compatible heart rate monitor near the console, the console will connect to the heart rate monitor with the strongest signal.

To disconnect your heart rate monitor from the console, press and hold the iFit Sync button on the console until the LED on the console turns solid green.

Note: All Bluetooth connections between the console and other devices (including any tablets, heart rate monitors, and so forth) will be disconnected.

HOW TO USE THE SOUND SYSTEM

To play music or audio books through the console sound system while you exercise, plug a 3.5 mm male to 3.5 mm male audio cable (not included) into the jack on the console and into a jack on your personal audio player; **make sure that the audio cable is fully plugged in.** Note: To purchase an audio cable, see your local electronics store.

Next, press the play button on your personal audio player. Adjust the volume level using the volume increase and decrease buttons on the console or the volume control on your personal audio player.

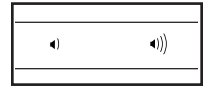

HOW TO CONNECT TO THE SOUND SYSTEM WITH BLUETOOTH

If desired, you can connect your smart device to the console sound system with Bluetooth.

First, make sure that the Bluetooth option is enabled on your device.

Next, place or hold your device near the console. Then, pair your device to the console as follows: Press and hold the Audio button on the console for 3 seconds; the console will enter pairing mode.



When your device and the console pair successfully, the audio from your device will play through the console sound system.

The console can save 8 devices in its memory. If you have previously paired your device to the console, simply press the Audio button to connect your device to the console.

You can erase devices from the console memory if necessary. To erase all the Bluetooth-enabled devices saved in the console memory, press and hold the Audio button for 10 seconds.

THE OPTIONAL CHEST HEART RATE MONITOR

Whether your goal is to burn fat or to strengthen your cardiovascular system, the key to achieving the best results is to maintain the proper heart rate during your workouts. The optional chest heart rate monitor will enable you to continuously monitor your heart rate while you exercise, helping you to reach your personal fitness goals. **To purchase a chest heart rate monitor, please see the front cover of this manual.**

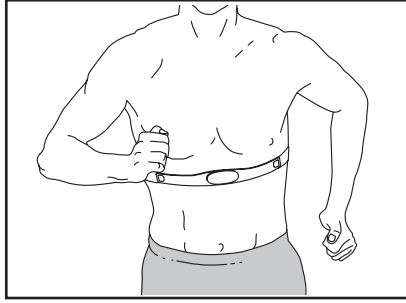

Note: The console is compatible with all Bluetooth Smart heart rate monitors.

HOW TO CHANGE CONSOLE SETTINGS

1. Select the settings mode.

To select the settings mode, press the Settings button. The settings information will appear in the display.

2. Navigate the settings mode.

While the settings mode is selected, the display will show several optional screens. Press the increase and decrease buttons near the Enter button repeatedly to select the desired optional screen.

The lower section of the display will show instructions for the selected screen. **Make sure to follow the instructions shown in the lower part of the display.**

Note: The display test and the button test optional screens are for use by service technicians. Please disregard these screens.

3. Change settings as desired.

Units—The currently selected unit of measurement will appear in the display. To change the unit of measurement, press the Enter button or the St/Met button repeatedly. To view workout information in standard units, select ENGLISH. To view workout information in metric units, select METRIC.

Contrast Level—The currently selected contrast level will appear in the display. Press the Resistance increase and decrease buttons to adjust the contrast level.

Usage Information—The display will show the total number of hours that the elliptical has been used and the total distance (in miles or kilometers) that has been pedaled on the elliptical.

Demo—The console features a display demo mode, designed to be used if the elliptical is displayed in a store. Press the Resistance increase button repeatedly to turn the demo mode on or off.

4. Exit the settings mode.

Press the Settings button to exit the settings mode.

MAINTENANCE AND TROUBLESHOOTING

MAINTENANCE

Regular maintenance is important for optimal performance and to reduce wear. Inspect and properly tighten all parts each time the elliptical is used. Replace any worn parts immediately.

To clean the elliptical, use a damp cloth and a small amount of mild soap. **IMPORTANT: To avoid damage to the console, keep liquids away from the console and keep the console out of direct sunlight.**

CONSOLE TROUBLESHOOTING

If the console does not display your heart rate when you hold the handgrip heart rate monitor, or if the displayed heart rate appears to be too high or too low, see step 5 on page 18.

If a replacement power adapter is needed, call the telephone number on the cover of this manual. IMPORTANT: To avoid damaging the console, use only a manufacturer-supplied regulated power adapter.

TABLET HOLDER TROUBLESHOOTING

If the tablet holder does not stay in place, rotate the tablet holder backward and tighten the screw (A) until the tablet holder stays in place when it is rotated to the desired position.

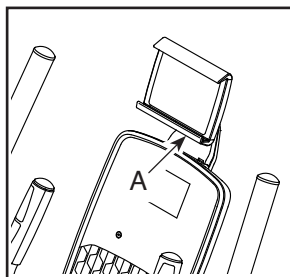

HOW TO ADJUST THE DRIVE BELT

If you can feel the pedals slip while you are pedaling, even when the resistance is adjusted to the highest level, the drive belt may need to be adjusted.

To adjust the drive belt, first **unplug the power adapter.**

Next, locate the Access Cover (29) in the Left Shield (30). Remove the M4 x 16mm Screw (78) and the Access Cover.

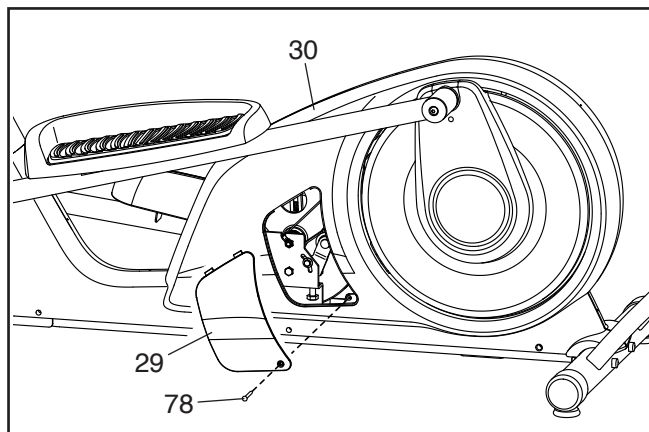

Next, loosen the Idler Screw (75). Then, tighten the M10 x 55mm Screw (65) until the Drive Belt (59) is tight.

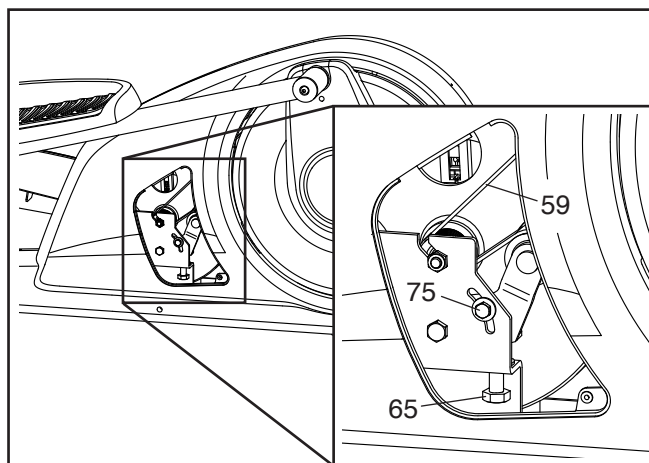

When the Drive Belt (59) is tight, tighten the Idler Screw (75). Then, reattach Access Cover (29) and plug in the power adapter.

HOW TO ADJUST THE REED SWITCH

If the console does not display correct feedback, the reed switch should be adjusted.

To adjust the reed switch, first **unplug the power adapter**. Next, using a standard screwdriver, pry off the right Disc Cover (34).

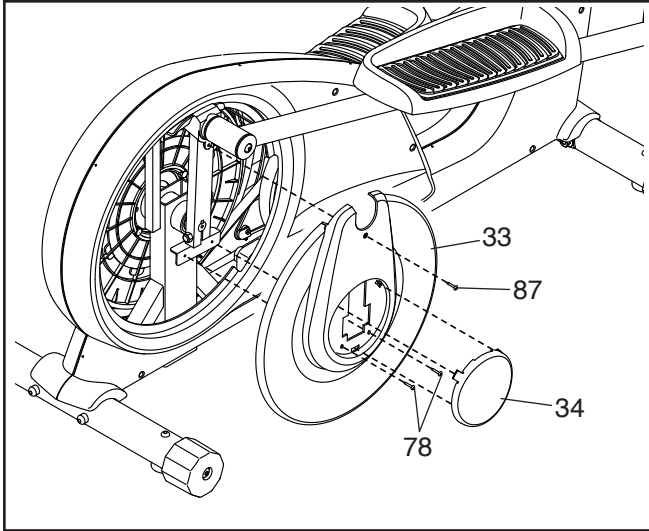

Then, remove the M4 x 15mm Machine Screw (87) and the two M4 x 16mm Screws (78) from the right Disc (33), and then remove the right Disc.

Locate the Reed Switch (44). Slightly loosen the two M4 x 16mm Screws (78).

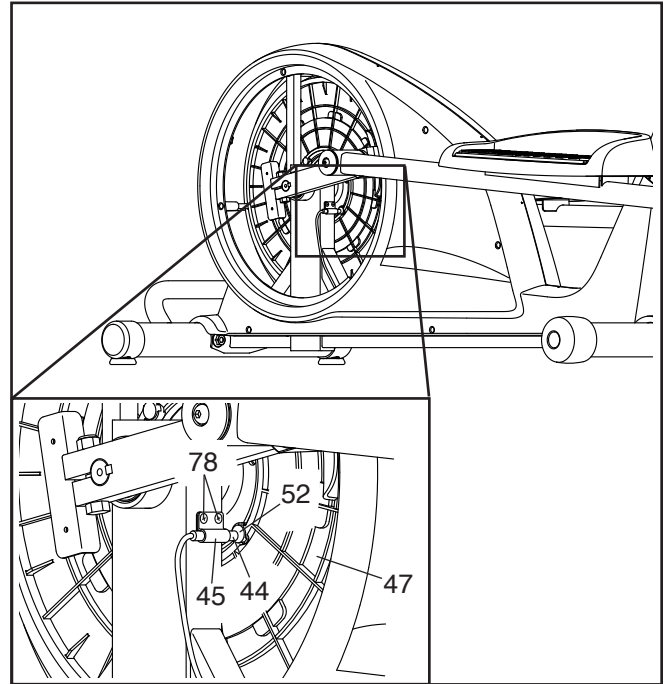

Next, rotate the Pulley (47) until a Magnet (52) is aligned with the Reed Switch (44). Slide the Reed Switch slightly toward or away from the Magnet. Then, retighten the M4 x 16mm Screws (78).

Plug in the power adapter and rotate the Pulley (47) for a moment. Repeat the procedure above, if necessary, until the console displays correct feedback.

When the reed switch is correctly adjusted, reattach the parts that you removed and plug in the power adapter.

EXERCISE GUIDELINES

⚠️ WARNING: Before beginning this or any exercise program, consult your physician. This is especially important for persons over age 35 or persons with pre-existing health problems.

The heart rate monitor is not a medical device. Various factors may affect the accuracy of heart rate readings. The heart rate monitor is intended only as an exercise aid in determining heart rate trends in general.

These guidelines will help you to plan your exercise program. For detailed exercise information, obtain a reputable book or consult your physician. Remember, proper nutrition and adequate rest are essential for successful results.

EXERCISE INTENSITY

Whether your goal is to burn fat or to strengthen your cardiovascular system, exercising at the proper intensity is the key to achieving results. You can use your heart rate as a guide to find the proper intensity level. The chart below shows recommended heart rates for fat burning and aerobic exercise.

165	155	145	140	130	125	115	♥
145	138	130	125	118	110	103	♥
125	120	115	110	105	95	90	♥
<hr/>							
20	30	40	50	60	70	80	

To find the proper intensity level, find your age at the bottom of the chart (ages are rounded off to the nearest ten years). The three numbers listed above your age define your “training zone.” The lowest number is the heart rate for fat burning, the middle number is the heart rate for maximum fat burning, and the highest number is the heart rate for aerobic exercise.

Burning Fat—To burn fat effectively, you must exercise at a low intensity level for a sustained period of time. During the first few minutes of exercise, your body uses carbohydrate calories for energy. Only after the first few minutes of exercise does your body begin to use stored fat calories for energy. If your goal is to burn fat, adjust the intensity of your exercise until your heart rate is near the lowest number in your training zone. For maximum fat burning, exercise with your heart rate near the middle number in your training zone.

Aerobic Exercise—If your goal is to strengthen your cardiovascular system, you must perform aerobic exercise, which is activity that requires large amounts of oxygen for prolonged periods of time. For aerobic exercise, adjust the intensity of your exercise until your heart rate is near the highest number in your training zone.

WORKOUT GUIDELINES

Warming Up—Start with 5 to 10 minutes of stretching and light exercise. A warm-up increases your body temperature, heart rate, and circulation in preparation for exercise.

Training Zone Exercise—Exercise for 20 to 30 minutes with your heart rate in your training zone. (During the first few weeks of your exercise program, do not keep your heart rate in your training zone for longer than 20 minutes.) Breathe regularly and deeply as you exercise; never hold your breath.

Cooling Down—Finish with 5 to 10 minutes of stretching. Stretching increases the flexibility of your muscles and helps to prevent post-exercise problems.

EXERCISE FREQUENCY

To maintain or improve your condition, complete three workouts each week, with at least one day of rest between workouts. After a few months of regular exercise, you may complete up to five workouts each week, if desired. Remember, the key to success is to make exercise a regular and enjoyable part of your everyday life.

PART LIST

Model No. NTEVEL57019.0 R0419A

Key No.	Qty.	Description	Key No.	Qty.	Description
1	1	Frame	50	1	Crank Bearing Sleeve
2	1	Upright	51	1	Crank Arm
3	2	Stabilizer	52	2	Magnet
4	4	M8 x 10mm Screw	53	4	Pedal Arm Bearing
5	1	Console	54	2	Pedal Arm Bearing Sleeve
6	1	Left Pedal	55	2	Pivot Spacer
7	1	Right Pedal	56	4	Pivot Bushing
8	2	Pedal Bracket	57	4	Pedal Arm Bushing
9	1	Left Upper Body Arm	58	2	Pedal Arm Cover
10	1	Right Upper Body Arm	59	1	Drive Belt
11	2	Grip	60	1	M3 x 12mm Screw
12	2	Grip Cap	61	1	M10 x 75mm Bolt
13	2	Upper Body Leg	62	4	M10 Locknut
14	2	Upper Body Arm Sleeve	63	2	M8 x 76mm Shoulder Screw
15	2	Knob	64	2	M6 Bolt Set
16	1	Left Pedal Arm	65	1	M10 x 55mm Screw
17	1	Right Pedal Arm	66	2	M8 x 14mm Shoulder Screw
18	1	Left Rear Arm Cover	67	6	M10 x 15mm Screw
19	1	Left Front Arm Cover	68	4	M10 x 25mm Shoulder Screw
20	1	Right Rear Arm Cover	69	2	M8 Jam Nut
21	1	Right Front Arm Cover	70	4	M10 x 82mm Screw
22	1	Handlebar	71	1	Key
23	2	Pulse Sensor/Wire	72	4	M8 x 15mm Screw
24	1	Accessory Tray	73	4	M4 x 12mm Flange Screw
25	1	Rear Upright Cover	74	2	Crank/Idler Washer
26	1	Front Upright Cover	75	1	Idler Screw
27	1	Rear Shield Cover	76	1	Idler Pivot Screw
28	1	Front Shield Cover	77	4	M4 x 12mm Screw
29	1	Access Cover	78	32	M4 x 16mm Screw
30	1	Left Shield	79	3	M10 x 20mm Screw
31	1	Right Shield	80	1	M10 Clamp Bolt
32	2	Disc Bracket	81	8	M6 x 12mm Screw
33	2	Disc	82	1	Ground Screw
34	2	Disc Cover	83	2	M8 Washer
35	4	Leveling Cap	84	2	M8 x 20mm Screw
36	4	Caster	85	1	M6 x 14mm Screw
37	4	Caster Spacer	86	2	M10 x 80mm Bolt
38	2	Rear Leg Cover	87	2	M4 x 15mm Machine Screw
39	2	Front Leg Cover	88	4	M8 Split Washer
40	1	Eddy Mechanism	89	1	Main Wire
41	1	Resistance Cable	90	1	Power Adapter
42	1	Idler	91	1	Upright Spacer
43	1	Resistance Motor	92	1	Console Plate
44	1	Reed Switch/Wire	93	1	Tablet Holder
45	1	Clamp	94	4	M4 x 16mm Machine Screw
46	1	Crank/Crank Arm	95	4	M4 x 10mm Screw
47	1	Pulley	*	–	User's Manual
48	2	Crank Arm Spacer	*	–	Assembly Tool
49	2	Crank Bearing	*	–	Grease Packet

Note: Specifications are subject to change without notice. For information about ordering replacement parts, see the back cover of this manual. *These parts are not illustrated.

EXPLODED DRAWING A

Model No. NTEVEL57019.0 R0419A

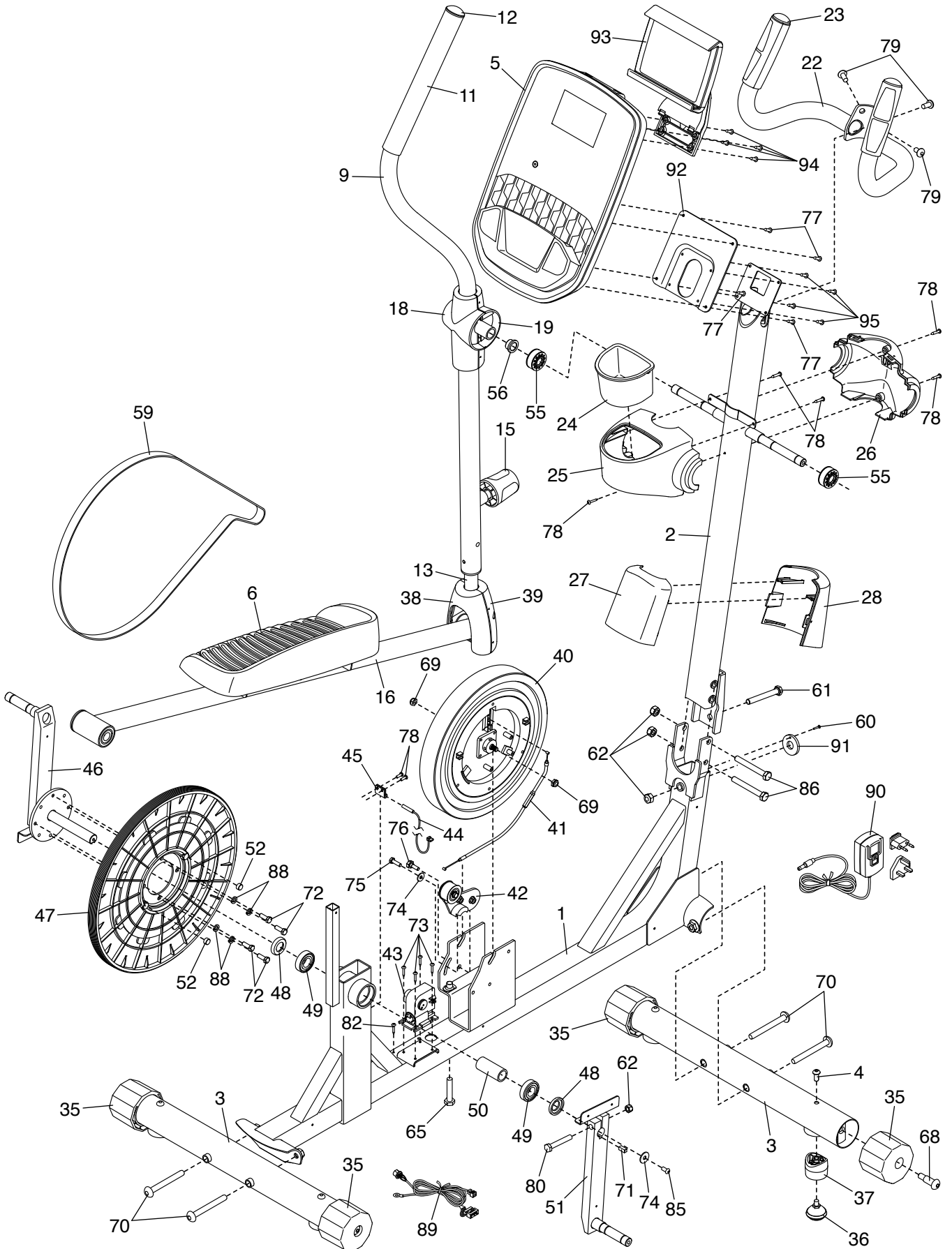

EXPLODED DRAWING B

Model No. NTEVEL57019.0 R0419A

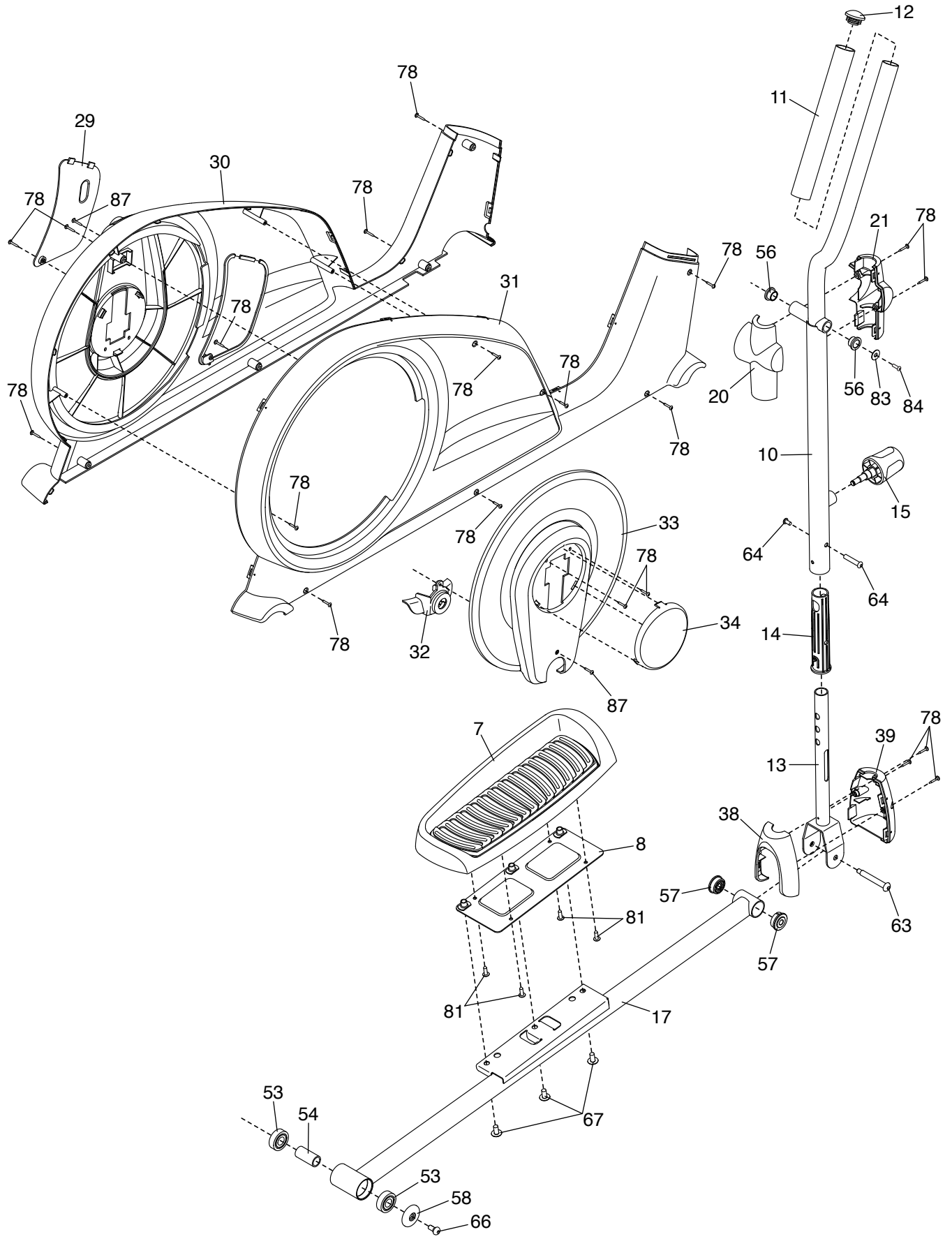

ORDERING REPLACEMENT PARTS

To order replacement parts, please see the front cover of this manual. To help us assist you, be prepared to provide the following information when contacting us:

- the model number and serial number of the product (see the front cover of this manual)
- the name of the product (see the front cover of this manual)
- the key number and description of the replacement part(s) (see the PART LIST and the EXPLODED DRAWING near the end of this manual)

RECYCLING INFORMATION

This electronic product must not be disposed of in municipal waste. To preserve the environment, this product must be recycled after its useful life as required by law.

Please use recycling facilities that are authorized to collect this type of waste in your area. In doing so, you will help to conserve natural resources and improve European standards of environmental protection. If you require more information about safe and correct disposal methods, please contact your local city office or the establishment where you purchased this product.

