

CBS-1251; CBS-1252 and CBS-1253 Extractor Plus Brewing System FETCO PLUS® Commercial Beverage Equipment



CBS-1251 & CBS-1252 1½ gallon brewer with FETCO 1½ Gallon L4D dispensers (sold separately) CBS-1253 2 gallon Extractor Plus Brewers



CONTACT INFORMATION

FETCO® FOOD EQUIPMENT TECHNOLOGIES COMPANY
600 ROSE ROAD
LAKE ZURICH • IL • 60047-0429 • USA
ON THE WEB: fetco.cofee
©2020-2024 FETCO
PATENTS: <https://www.fetco.com/pl.pages.patents.74.html>



PHONE: (800) 338-2699 (US & CANADA)
(847) 719-3000 (All Countries)
FAX: (847) 719-3001
EMAIL: sales@fetco.com
orders@fetco.com (to order parts and equipment)
techsupport@fetco.com (all service queries)

P213 REV. 002 October 2024

Coffee Brewer: CBS-1250 series

TABLE OF CONTENTS

Specifications and Requirements	2	F Service Menu	13
Electrical Configurations	3	G Counters	15
Enter Programming	6	Operator Training	17
Programing Menu Layout	6	Parts Diagram CBS-1251	22
A Program	8	Parts Diagrams CBS-1252 and CBS-1253	24
B General	9	CBS-1251 Tank Assembly	26
C Service Inputs	10	CBS-1252 and CBS1253 Tank Assembly	28
D Service Outputs	10	Quick connect spray head assembly	32
E Calibration	11	Wiring Diagrams	33



Specifications and Requirements

Water Requirements:

CBS-1251; CBS1252 & 1253:
20-75 psig, (138-517kPa) 1½gpm/(5.7lpm)

Water inlet fitting is a 3/8 inch male flare.

Brewer supplied with inlet valve adaptor for BSP to SAE

CBS-2151 and CBS-2152

Brew Volume: First Batch 1½ gallons/ 6 liters

Second Batch 1 gallon/ 3.8 liters

CBS-2153 -2 gallon

Brew Volume: First Batch 2 gallons/ 7.6 liters

Second Batch 1 gallon/ 3.8 liters

Total Brew Cycle—Factory Default Settings

CBS-2151 1½ gal Factory default setting

First batch 1½ gal: 6:30 minutes=[5 minute brew time + 1.30 minute drip delay] + 10% Bypass

Second batch-1 gallon: 5:30 minutes=[4 minute brew time + 1.30 minute drip delay] + 0% Bypass

CBS-2152 1½ gal Factory default setting:

First batch 1½ gal: 6:30 minutes=[5 minute brew time + 1.30 minute drip delay] + 15% Bypass

Second batch-1 gallon: 5:30 minutes=[4 minute brew time + 1.30 minute drip delay] + 0% Bypass

CBS-2153-2 gallon Factory default setting:

First batch 2 gal: 6:30 minutes=[5 minute brew time + 1.30 minute drip delay] + 15% Bypass

Second batch-1 gallon: 5:30 minutes=[4 minute brew time + 1.30 minute drip delay] + 0% Bypass

Brew-Process parameters are user controllable for:

Brew Volume, Brew Time, Prewet Percent, Bypass, Prewet Delay, and Drip Delay

Electrical:

See electrical configuration charts. CBS-1250 series brewers use a terminal block for electrical connection

Tank Temperature, as set by factory:

200°F (93°C) inside water tank (at sea level)

Water supply: (Optimal) 100-150TDS

All beverage equipment must use filtered water.

Weights and Capacities

Model	Height	Width	Depth	Water tank capacity	Empty Weight	Filled Weight	Shipping Weight	Shipping Dimensions
CBS-1251 1½ gal	36 7/8 in 940 mm	12 3/4 in 320 mm	22 1/2 in 570 mm	6.5 gallon 24.4 L	53 lbs 24 kg	107 lbs 48.3kg	63 lbs 28.6 kg	38" x 18" x 24" 96.5 x 45.7 x 61 cm
CBS-1252 1½ gal	36 7/8 in 940 mm	21 7/8 in 550 mm	22 1/2 in 570 mm	11.1 gallon 42.1 L	77 lbs 35.0 kg	174 lbs 78.9 kg	97 lbs 44 kg	38" x 24" x 27" 96.5 x 61 x 68.6 cm
CBS-1253 2 gal	39 in 99.1 mm	21 7/8 in 550 mm	22 1/2 in 570 mm	11.1 gallon 42.1 L	82 lbs 37.2 kg	180 lbs 81.6 kg	97 lbs 44 kg	40" x 24" x 27" 102 x 61 x 68.6 cm

CBS-1251 & CBS-1252
Calibrated for
1½ gallons/6 liters

CBS-1253
Calibrated for
2 gallons/8 liters

Filter Paper all models
15" X 5 ½" – standard
Or use FETCO # F001

Most brewers ship with plastic brew baskets.
See page 31 for other, optional brew baskets

Rough-In Drawings

1201.00053.00 (CBS-1251) 1201.00052.00 (CBS-2152)

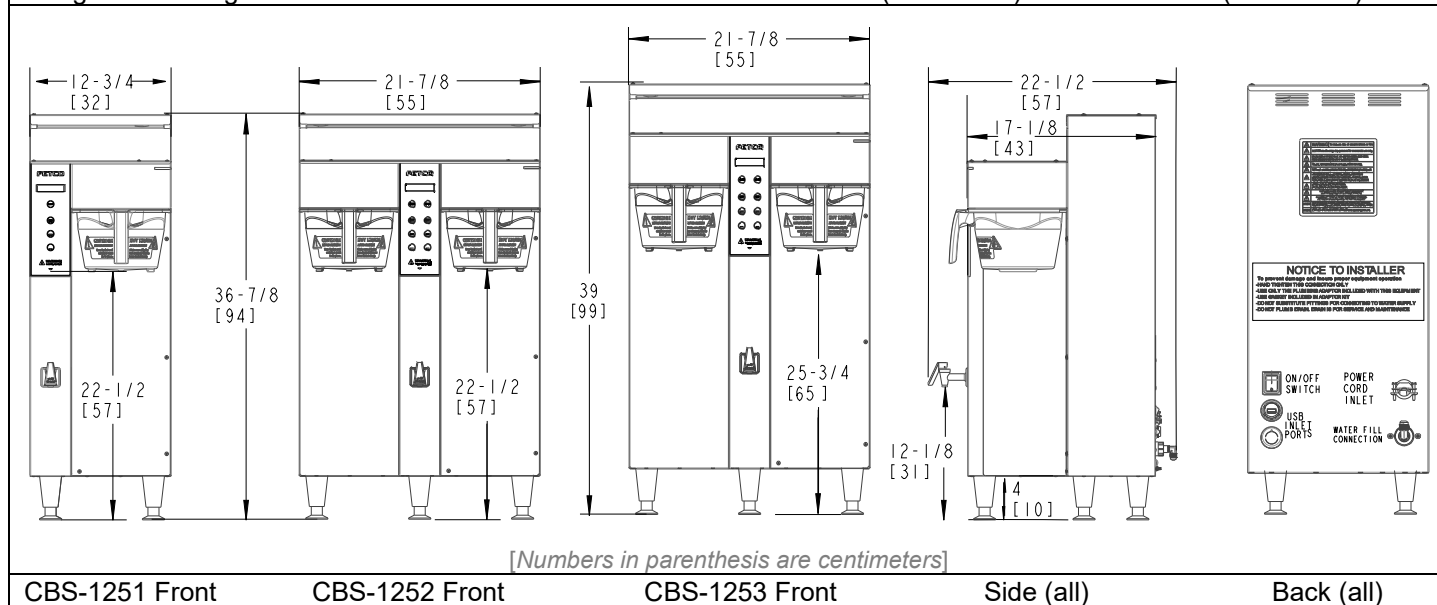

EXAMPLE: SKU E1253US-UB230-PM110													SKU NUMBER IDENTIFICATION KEY			
Product Line	Level		Family		Region ID		Phase	Voltage Range	# Heaters	Indivi Heater	Twin Wattage	Brew Basket	Hot Water Faucet	Bypass	Brew Basket Locks	Power Cord
E	1	2	5	3	U	S	U	B	2	5	0	P	M	01	1	0
E=extractor	12=PLUS Series		51= single side		US =United States		1	A = 100-120	1	1.5		P=plastic	M=manual	1=Yes	1=Yes	0=Terminal Block
			52= Twin side		IN = International		2	B = 200-240	2	1.7		M=metal	A=automatic	0=no	0=no	1= NEMA 5-15P
			53= Twin side 2 gallon		CE = CE		3	C = 380-415	3	2.3			N=None			2=NEMA 5-20P
					NM = NOM		U = 1 or 3	D = 440-480		3.0						3=NEMA 6-15P
								X=120 or 240 Twin Voltage		4.0						4=NEMA 6-30P
										5.0						5= CEE 7/7 Schuko
																6=UK1-13P
																7= AUSTRALIAN
																8=Brazil

Electrical Configurations CBS-1251 Plus Single Side 1½ gallon brewer

CBS-1251PLUS Single 1½ Gallon-6 Liter Coffee Brewers Domestic and International models							
Electrical and Output Specifications All brewers have terminal block electrical utility							
Configuration Codes	Heater Configuration	Voltage	Phase	Wires	KW	Amp Draw	Brew-Volume/Hour
E1251US-1B230-PM110	2 X 3.0 kW	208-240	1	2+G	4.5-6.0	22.2-25.5	15.0 gal/57 liters
*E1251US-1B230-PM100	2 X 3.0 kW	208-240	1	2+G	4.5-6.0	22.2-25.5	15.0 gal/57 liters
E1251US-1B230-MM110	2 X 3.0 kW	208-240	1	2+G	4.5-6.0	22.2-25.5	15.0 gal/57 liters
E1251IN-1B140-PM110	1 X 4.0 kW	200-240	1	2+G	2.8-4.0	14.4-17.2	10.6 gal/40.3 liters
E1251IN-1B150-PM110	1 X 5.0 kW	200-240	1	2+G	3.5-5.0	17.9-21.3	13.3 gal/50.4liters
E1251IN-1B230-PM110	2 X 3.0 kW	200-240	1	2+G	4.2-6.0	21.3-25.5	15.0 gal/57 liters

*Sold without brew basket lock.

CBS-1251PLUS Single 1½ Gallon-6 Liter Coffee Brewers International models							
Electrical and Output Specifications All brewers have terminal block electrical utility connection† 50Hz or 60Hz							
Configuration Codes	Heater Configuration	Voltage	Phase	Wires	KW	Amp Draw	Brew-Volume/Hour
E1251NM-1B230-PM110	2 X 3.0 kW	208-240	1	2+G	4.2-6.0	21.3-25.5	15.0 gal/57 liters
E1251KS-1B230-PM110	2 X 3.0 kW	220	1	2+G	5.2	23.4	13.0 gal/49 liters
E1251CE-1B230-PM110	2 X 3.0 kW	230/400	1	2L/N/PE	5.6	12.5	14.9 gal/ 56.4 liters
†*E1251CE-1B130-MM005	1 X 3.0 kW	230	1	L/N/PE	2.8	12.5	7.7 gal/ 29.1 liters
E1251BR-1B230-PM110	2 X 3.0 kW	220	1	L/N/PE	5.2	23.4	13.0 gal/49 liters

*Sold without brew basket lock

†This equipment includes a factory installed power cord with a CEE 7/7 Schuko plug and does not require installer to connect to the terminal block.

NOTES:

- Advanced electronics enable this equipment to operate with a 50-60 Hz frequency range without affecting the circuit or requiring user adjustments.
- NM in SKU suffix (above) denotes equipment with NOM certification, Spanish labeling for Mexico and Spanish language user guide
- The "KS" in the SKU suffix indicates GCC equipment with CB Scheme certification, labeling for KSA, and Arabic language user guide.
- The "BR" in the SKU suffix indicates Brazil equipment with CB Scheme certification, Type N plug, labeling and Portuguese for Brazil language user guide.
- The "CE" in the suffix (above) indicates equipment with a current CB scheme supporting CE marking. This equipment is not cUL/UL certified

CBS-1252 Plus Twin 1½ Gallon Coffee Brewers continued on following page

Electrical Configurations CBS-1252 Plus Twin Side 1½ gallon brewer

CBS-1252Plus Twin 1½ Gallon-6 Liter Coffee Brewers Field configurable Domestic with cUL/UL & NSF-4 Certification Electrical and Output Specifications All brewers have terminal block electrical utility connection 50Hz or 60Hz							
Configuration Codes	Heater Configuration	Voltage	Phase	Wires	KW	Amp Draw	Brew Volume/Hour
E1252US-UB230-PM110 Selectable (1 or 3 phase) Sold as single phase (see pg.34)	2 X 3.0 kW	208-240	1	2+G	4.5-6.0	22.2-25.5	15.9 gal/60.4 liters
	3 X 3.0 kW	208-240	3	3+G	6.8-9.0	19.3-22.2	23.9 gal/90.6 liters
E1252US-UB230-MM110 Selectable (1 or 3 phase) Sold as single phase (see pg.34)	2 X 3.0 kW	208-240	1	2+G	4.5-6.0	22.2-25.5	15.9 gal/60.4 liters
	3 X 3.0 kW	208-240	3	3+G	6.8-9.0	19.3-22.2	23.9 gal/90.6 liters
E1252US-UB250-PM110 Selectable (1 or 3 phase) Sold as single phase (see pg.34)	2 X 5.0 kW	208-240	1	2+G	7.6-10.0	36.6-42.2	25.3 gal/97 liters
	3 X 5.0 kW	208-240	3	3+G	11.3-15.0	31.8-36.6	30.0 gal/114 liters
E1252US-UB250-MM110 Selectable (1 or 3 phase) Sold as single phase (see pg.34)	2 X 5.0 kW	208-240	1	2+G	7.6-10.0	36.6-42.2	25.3 gal/97 liters
	3 X 5.0 kW	208-240	3	3+G	11.3-15.0	31.8-36.6	30.0 gal/114 liters

Field configurable brewers are shipped from factory in single phase configuration.
Instructions are provided for licensed installer to configure wiring at terminal block for three phase configuration.

CBS-1252PLUS Twin 1½ Gallon-6 Liter Coffee Brewers Domestic and International models single voltage With cUL/UL & NSF-4 Certification and listed in a CB test report Electrical and Output Specifications Single-Voltage. Brewers have terminal block electrical utility connection 50Hz or 60Hz							
Configuration Codes	Heater Configuration	Voltage	Phase	Wires	KW	Amp Draw	Brew Volume/Hour
E1252IN-1B230-PM110	2 X 3.0 kW	200-240	1	2+G	4.2-6.0	21.3-25.5	15.9 gal/60.4 liters
E1252IN-1B250-PM110	2 X 5.0 kW	200-240	1	2+G	7.0-10.0	35.2-42.2	26.6gal/100.7liters

CBS-1252Plus Twin 1½ Gallon-6 Liter Coffee Brewers Specialty International models NSF-4 Certified Electrical and Output Specifications All brewers have terminal block electrical utility connection 50Hz or 60Hz							
Configuration Codes	Heater Configuration	Voltage	Phase	Wires	KW	Amp Draw	Brew Volume/Hour
E1252IN-3C330-PM110	3 X 3.0 kW	220/380 240/415	3	4+G	7.6-9.0	12.0-12.9	23.9 gal/90.6 liters
E1252IN-3C340-PM110	3 X 4.0 kW	220/380 240/415	3	4+G	10.1-12.0	15.8-17.2	30.0 gal/114 liters
E1252IN-3C350-PM110	3 X 5.0 kW	220/380 240/415	3	4+G	12.6-15.0	19.6-21.3	30.0 gal/114 liters
E1252CE-3C330-PM110	3 X 3.0 kW	230/400	3	3L/N/PE	8.3	12.5	22.1gal/83.6 liters
E1252CE-3C350-PM110	3 X 5.0 kW	230/400	3	3L/N/PE	13.8	20.5	30.0 gal/114 liters
Configuration Codes	Heater Configuration	Voltage	Phase	Wires	KW	Amp Draw	Brew Volume/Hour
Field configurable version							
E1252NM-UB250-PM110 Selectable (1 or 3 phase) Sold as single phase (see pg.34)	2 X 5.0 kW	208-240	1	2+G	7.6-10.0	36.6-42.2	26.6 gal/101 liters
	3 X 5.0 kW	208-240	3	3+G	11.3-15.0	31.8-36.6	30.0 gal/114 liters
E1252NM-1B250-PM110	2 X 5.0 kW	200-240	1	2+G	7.0-10.0	35.2-42.2	26.6gal/100.7liters
Single voltage versions							
E1252KS-3C330-PM110	3 X 3.0 kW	220/380 240/415	3	4+G	7.6-9.0	12.0-12.9	23.9 gal/90.6 liters
E1252KS-3B330-PM110	3 X 3.0 kW	230/400	3	3L/N/PE	8.3	12.5	22.1gal/83.6 liters
E1252BR-1B250-PM110	2 X 5.0 kW	220	1	L/N/PE	8.5	38.6	27gal/102 liters

NOTES:

- Advanced electronics enable this equipment to operate with a 50-60 Hz frequency range without affecting the circuit or requiring user adjustments.
- NM in SKU suffix (above) denotes equipment with NOM certification, Spanish labeling for Mexico and Spanish language user guide
- The "KS" in the SKU suffix indicates GCC equipment with CB Scheme certification, labeling for KSA, and Arabic language user guide.
- The "BR" in the SKU suffix indicates Brazil equipment with CB Scheme certification, Type N plug, labeling and Portuguese for Brazil language user guide.
- The "CE" in the suffix (above) indicates equipment with a current CB scheme supporting CE marking. This equipment is not cUL/UL certified

CBS-1253Plus Twin 2 Gallon/8 Liter Coffee Brewers continued on following page



Electrical Configurations CBS-1253 Plus Twin Side 2 gallon brewer

CBS-1253Plus Twin 2 Gallon-8 Liter Coffee Brewers Field configurable Domestic							
Electrical and Output Specifications All brewers have terminal block electrical utility connection 50Hz or 60Hz							
Configuration Codes	Heater Configuration	Voltage	Phase	Wires	KW	Amp Draw	Brew-Volume/Hour
E1253US-UB230-PM110 Selectable (1 or 3 phase) Sold as single phase (see pg.34)	2 X 3.0 kW	208-240	1	2+G	4.5-6.0	22.2-25.5	15.9 gal/60.4liters
	3 X 3.0 kW	208-240	3	3+G	6.8-9.0	19.3-22.2	23.9 gal/90.6liters
E1253US-UB230-MM110 Selectable (1 or 3 phase) Sold as single phase (see pg.34)	2 X 3.0 kW	208-240	1	2+G	4.5-6.0	22.2-25.5	15.9 gal/60.4liters
	3 X 3.0 kW	208-240	3	3+G	6.8-9.0	19.3-22.2	23.9 gal/90.6liters
E1253US-UB250-PM110 Selectable (1 or 3 phase) Sold as single phase (see pg.34)	2 X 5.0 kW	208-240	1	2+G	7.6-10.0	36.6-42.2	25.3 gal/97 liters
	3 X 5.0 kW	208-240	3	3+G	11.3-15.0	31.8-36.6	30.0 gal/114 liters
E1253US-UB250-MM110 Selectable (1 or 3 phase) Sold as single phase (see pg.34)	2 X 5.0 kW	208-240	1	2+G	7.6-10.0	36.6-42.2	25.3 gal/97 liters
	3 X 5.0 kW	208-240	3	3+G	11.3-15.0	31.8-36.6	30.0 gal/114 liters

Brewers are shipped from factory in single phase configuration.
Instructions are provided for licensed installer to configure wiring at terminal block for three phase configuration.

CBS-1253Plus Twin 2 Gallon-8 Liter Coffee Brewers Domestic and International models							
Electrical and Output Specifications All brewers have terminal block electrical utility connection 50Hz or 60Hz							
Configuration Codes	Heater Configuration	Voltage	Phase	Wires	KW	Amp Draw	Brew-Volume/Hour
E1253IN-1B230-PM110	2 X 3.0 kW	200-240	1	2+G	4.2-6.0	21.3-25.5	15.9 gal/60.4 liters
E1253IN-1B250-PM110	2 X 5.0 kW	200-240	1	2+G	7.0-10.0	35.2-42.2	26.6gal/100.7liters
E1253BR-1B250-PM110	2 X 5.0 kW	220	1	L/N/PE	8.5	38.6	27gal/102 liters

CBS-1253PlusTwin 2 Gallon-8 Liter Coffee Brewers Specialty International models							
Electrical and Output Specifications All brewers have terminal block electrical utility connection 50Hz or 60Hz							
Configuration Codes	Heater Configuration	Voltage	Phase	Wires	KW	Amp Draw	Brew-Volume/Hour
E1253IN-3C330-PM110	3 X 3.0 kW	220/380 240/415	3	4+G	7.6-9.0	12.0-12.9	23.9 gal/90.6 liters
E1253IN-3C340-PM110	3 X 4.0 kW	220/380 240/415	3	4+G	10.1-12.0	15.8-17.2	30.0 gal/114 liters
E1253IN-3C350-PM110	3 X 5.0 kW	220/380 240/415	3	4+G	12.6-15.0	19.6-21.3	30.0 gal/114 liters
Field configurable version							
E1253NM-UB250-PM110 Selectable (1 or 3 phase) Sold as single phase (see pg.34)	2 X 5.0 kW	208-240	1	2+G	7.6-10.0	36.6-42.2	25.3 gal/97 liters
	3 X 5.0 kW	208-240	3	3+G	11.3-15.0	31.8-36.6	30.0 gal/114 liters
Single voltage version							
E1253NM-1B250-PM110	2 X 5.0 kW	200-240	1	2+G	7.0-10.0	35.2-42.2	26.6gal/100.7liters
CE models All brewers have terminal block electrical utility connection Supported by CB test report. NSF-4 listed, NOT UL or cUL 50Hz or 60Hz							
E1253CE-3C330-PM110	3 X 3.0 kW	230/400	3	4+G	7.6-9.0	12.0-12.9	23.9 gal/90.6 liters
E1253CE-3C350-PM110	3 X 5.0 kW	230/400	3	4+G	12.6-15.0	19.6-21.3	30.0 gal/114 liters

NOTES:

- Advanced electronics enable this equipment to operate with a 50-60 Hz frequency range without affecting the circuit or requiring user adjustments.
- NM in SKU suffix (above) denotes equipment with NOM certification, Spanish labeling for Mexico and Spanish language user guide
- The "KS" in the SKU suffix indicates GCC equipment with CB Scheme certification, labeling for KSA, and Arabic language user guide.
- The "BR" in the SKU suffix indicates Brazil equipment with CB Scheme certification, Type N plug, labeling and Portuguese for Brazil language user guide.
- The "CE" in the suffix (above) indicates equipment with a current CB scheme supporting CE marking. This equipment is not cUL/UL certified



Enter Programming

- Turn the brewer OFF from the power switch.
- Turn the brewer ON. Brewer will boot up. After 10 seconds the STOP button will illuminate red
- Press and release the STOP button when it illuminates (red LED)

First stage of the Programming Menu will be in A-10 Batch Parameters. This is the most common programming.

Screens shown are for twin brewer. Single brewer will not have menu A4-A6.

There are seven menu groups-A-G . See the following pages for the batch parameter definitions and all settings for the brewer

TO ENTER PROGRAMMING

- 1-Turn brewer "OFF" from power switch
- 2-Turn power switch to "ON"
- ...Screen will initialize and then display digital process notifications
- 3-After Initialization-Red "STOP" Lamp turns on
- 4-Quickly press "STOP" button.

When brewer is In PROGRAMMING MODE
-the screen will display:

BATCH PRG!
A (or B-H)

-Illuminated LED indicates active keypad positions

See the following pages for batch parameter definitions and all settings for the brewer

Note: Only the left side buttons of a two sided brewer are used for programming

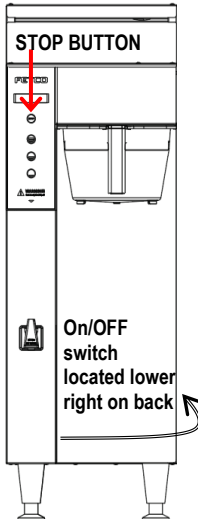

Turn power OFF
Turn power ON
Wait for red LED
And quickly press STOP button on front touch pane

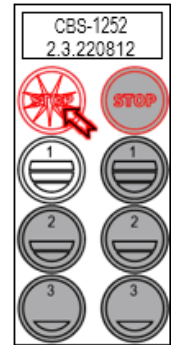

First screen will display for PROGRAMMING-A
Scroll through main menu topics by pressing "STOP" button.

Programing Menu Layout

A10 to A70		B10-B40		C10-C50		D10-D90		E10-E70		F10-F120		G1-G15		H10-H11	
Batch Parameters		General Settings		Service Inputs		Service Outputs		Calibration		Service Menu		Counters		Exit and Save	
A11	Brew Volume	B1	Tank Temperature	C1	LLC Probe	D1	Heater SSR	E1	Ready Temp. Offset	F1	Firmware Ver.	G1	Filter Used	H1	Save Changes
A12	Brew Time	B2	Brew at Temp	C2	Basket Sensor	D2	Fill Valve	E2	LLC Sensitivity	F2	Bootloader Ver.	G2	Filter Life	H2	EXIT?
A13	Prewet Percent	B4	Show Tank Temp	C4	Tank Temperature	D3	Lt Brew Valve	E3	Slow Flow Compensate	F3	Select Model	G3	Filter Reset		
A14	Prewet Delay	B5	Units of Temp	C5	USB Drive	D4	Rt Brew Valve	E4	Lt Brew Flow	F4	Option Bypass	G4	Counter Reset		
A15	Bypass Percent	B6	Units of Volume	C6	Keyboard Test	D5	Lt Bypass Valve	E5	Rt Brew Flow	F5	Option BB Lock	G5	Choose Counter		
A16	Drip Delay	B7	Customer Name			D6	Rt Bypass Valve	E6	Lt Bypass Flow	F8	Backup to USB	G10	Brewer Volume [T]		
A20	Batch (2) Enabled	B8	Customers Name			D7	Lt Basket Lock	E7	Rt Bypass Flow	F9	Restore from USB	G11	Brewer Volume		
A21	Brew Volume	B9	Demo Mode			D8	Rt BasketLock			F10	Restore Defaults	G12	LT Brews[T]		
A22	Brew Time	B10	Eco Mode			D12	LCD Brightness %			F11	Error Log	G13	LT Brews		
A23	Prewet Percent	B11	Eco Idle Time			D13	LED Brightness %			F12	Erase Error Log	G14	Rt Brews [T]		
A24	Prewet Delay	B12	Eco Idle Temp							F13	Service Phone#	G15	Rt Brews		
A25	Bypass Percent	B13	Water Filter							F14	Override Lt BBS		See page 12		
A26	Drip Delay									F15	Override Rt BBS				
A30	Batch (3) Enabled									F16	Override Lt BBL				
A90	Copy Batch									F17	Override Rt BBL				
A91	Copy Batch: From														
A92	PASTE: To														

Top and middle batches are permanent SEE BOX on the following page for all "A" menus

The Brew Sequence

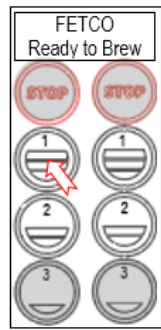

First screen shows top left brew position being activated ...

Right side is in "READY-MODE" during brew, and can be accessed for brewing



STOP brew lamp activates and top left button will pulsate.

All other buttons on the left side extinguish.

Count down timer activates beginning 5:30 for Batch 1 (5:00 for Batch 2)

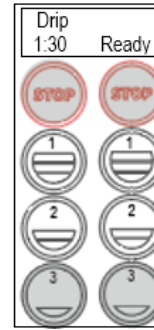

The brewing cycle completes in four minutes. Stop button extinguishes and drip out starts at 1:30 minutes.

Do not remove brew basket during this part of the cycle.

Brewer returns to "ready to brew" (screen one) after drip out completes

RECIPE Location map

Viewing and changing settings for the brew recipes is from the "A" screens with the controls in PROGRAMMING.

The uppermost button positions are permanent and will not display programming step A_0. The table above shows in position A20 that a button position can be made **active or inactive**. Position A1 does not display this step

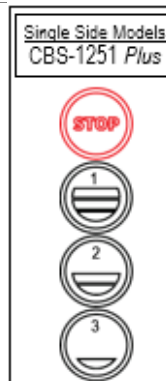

←DISPLAY→

←STOP→

←BATCH A1→
(permanent)

←BATCH A2→
(enabled by factory)

←BATCH A3→
(disabled by factory)

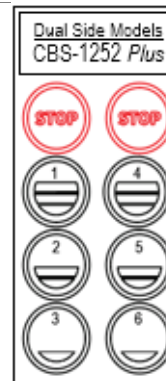

←DISPLAY

←STOP

←BATCH A4
(permanent)

←BATCH A5
(enabled by factory)

←BATCH A6
(disabled by factory)

The "A" menu is the most accessed menu. It is for programming the batch volumes, setting brewing parameters, enabling or disabling brew buttons. The "A" menu moves through the six positions (CBS-1252-) or three positions (CBS-1251+) by entering the menu and pressing the left stop button. (only the left side is active for programming the CBS-1252+)

The A menus [A1-3 or A1-6] correspond to batch buttons [3 or 6] on the touch panel

Access the A menus to PROGRAM & make changes to individual menu recipes. Menu settings can be copied

Menu positions A1 and A4 [top position] are permanent. Menus A2, A3, A5, A6 can be removed by operator if desired
A1 is top left A4 is top right. A1 & A4 are the only permanent positions and are factory set at 1.5gallons. Both are adjustable.

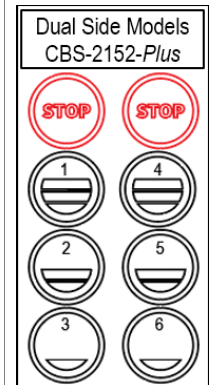
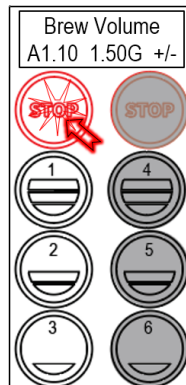
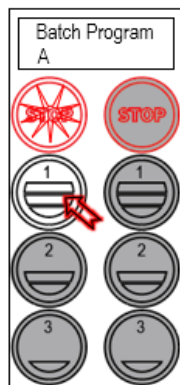
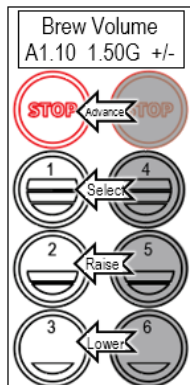

STOP-advances to the next menu programming position (A1 to A9 then to A.B.C.D...)

BUTTON #1-selects program items in the menu

BUTTONS 3 & 4 raise and lower the selection in the menu

Pressing the STOP button advances the next screen A20

A PRG screen
Press button 1 to go into to the A menu access screens.
Continue pressing button #1 to enter programming for A1

A11 screen
A11 sets the top left side brew button programming. Access brewing parameters by pressing button #1.
(Brew Volume, Time, Prewet & Drip Delay)

A20 screen
Press STOP to scroll through the remaining (3 to 6) "A" menus. Make any changes as required

A6.00 screen
Scroll to remaining A10-to A60 programming keys. Changes will be lost unless they are saved in the programming routine.
See SAVE & EXIT in previous table

Single&Twin Brewers
Position of batch buttons for CBS-1252+

The CBS-1251+ single position brewer has one row of buttons

A Program Menu Features: Batch Parameters					
The settings below are shown for the top batch on a single brewer top left button on a twin brewer. See how to access all A menus on the previous page. Below are the brew settings for default A1 & A2 batches					
POSITION	Program Items	Factory set Default	Programming Range	Increments	Notes
A1.10	Batch Volume	1.5 gal 6.8 liters	0.51 to 2.00 gal 1.93 to 7.57L	0.01G 0.05L	
A1.10	Batch Volume CBS-2153 only	2 gallons 9.1 liters	0.51 to 2.66 gal 1.93 to 10.1L	0.01G 0.05L	
A1.20	Brew Time	5:00 minutes	2:00 – 12:00	0.30	Default total brew time is 6:30 minutes
A1.30	Prewet Perc.	0%	0.00 – 25.0%	1%	Percentage of total brew volume
A1.40	Prewet Delay (Pause after prewet completes)	0% [1:00 Min]	[0:10 – 5:00]	1:00 min	The time between prewetting and start of brew cycle. This feature appears ONLY if Prewet >0:00
A1.50	Bypass Percent	CBS-1251:10% CBS-1252/3:15%	0% – 40%	1%	Diverts brewing water from brew process
A1.60 This is a Safety Feature	Drip Delay	1:30 mm:ss	0:30 – 6:00 Min.		Time that brew basket remains locked during final drip-out →Drip delay remains “ON” for 1:30 minutes if STOP is pressed during brew†
A2.00	BATCH ENABLED	YES (Active)	Middle and Bottom batches A2,3,5,6	Batch on or off	Batches may be individually enabled, rewritten or deactivated
A2.10	Batch Volume	1.5 gal 6.8 liters	0.51 to 2.00 gal 1.93 to 7.57L	0.01G 0.05L	
A2.10	Batch Volume CBS-2153 only	2 gallons 9.1 liters	0.51 to 2.66 gal 1.93 to 10.1L	0.01G 0.05L	
A2.20	Brew Time	4.00 minutes	2:00 – 12:00	0.30	Default total brew time is 5:30 minutes
A2.30	Prewet Perc.	0%	0.00 – 25.0%	1%	Percentage of total brew volume
A2.40	Prewet Delay (Brew pause after prewet completes)	0% [1:00 Min]	[0:10 – 5:00]	1:00 min	The time between prewetting and start of brew cycle. This feature appears ONLY if Prewet >0:00
A2.50	Bypass Percent	CBS-1251:0% CBS-1252&3: 0%	0% – 40%	1%	Diverts brewing water from brew process
A2.60 This is a Safety Feature	Drip Delay	1:30 mm:ss	0:30 – 6:00 Min.		Time that brew basket remains locked during final drip-out →Drip delay remains “ON” for 1:30 minutes if STOP is pressed during brew†
A30	Batch Enabled A30 YES - NO +	NO-inactive (defaults to recipe A20 if activated)	Middle and Bottom batches A2,A3	Batch on or off	Batches may be individually enabled, rewritten or deactivated
A90 Batch Copy	Copy From Batch	A90	A90 1 (1-6)		
A91	Copy To Batch?	A91	A91.1 (1-6)		

PULSE BREW note. FETCO CBS-1200V+ brewers are factory programmed to pulse 2 cycles per minute brew time Changing the brew time only will increase the pulses but will not change the volume of brew water delivered



B General Brewer Operation Control Settings, Adjust Brew Flow Rate					
POSITION	Program Items	Factory set Default	Programming Range	Increments	Notes
B1	Tank Temp.	200°F-or-93° C NOTE: Equipment is Fahrenheit by default	77° to 97°C 170°F to 207°F	0.5°C 1.0°F	Chart to correct for high altitude below
B2	Brew at Temp.	“YES”	ON/OFF	YES/NO	SEE NOTE BELOW
B4	Show Tank Temperature	YES	YES/NO		To display HW tank temperature on screen
B5	Units of Measure TEMPERATURE	F°-Fahrenheit	Fahrenheit/Celsius	C/F	NOTE: Overwrites user settings (see page 9)
B6	Units of Measure VOLUME	G-Gallons	Gallons/Liters/Ounces	Gal/L/Oz	NOTE: Overwrites user settings (see page 9)
B7	Customer Name	Off	NO or YES		For name on screen
B8	Customer Name	(only if above is “ON)	Scroll with batch keys	A-Z;a-z;0-9	16 characters total
B9	Demo Mode	DEMO ON/OFF			Demonstrates the controls for training. Disables all components in demo mode
B10	Eco Mode	On	ON/OFF	YES/NO	If Selected: Lowers hot water tank temperature after preset time of inactivity
B11	Eco Idle Time	1Hr	1-6 hours	1 hour	Time of inactivity to go into ECO Mode
B12	Eco Idle Temp	170°F	158-176°F	1 degree	Temperature that hot water tank is lowered to
B13	Water Filter	OFF	ON/OFF	YES/NO	Water filter life is accessed in G-Counters. This is user set and will display indicator to change water filter

BREW AT TEMPERATURE DEFINITIONS

DEFAULT: BREW AT TEMP: “ON”	
<p>(FACTORY DEFAULT FOR BREWER)</p> <p>“BREW at TEMP:</p> <p>-Batch will not start if tank temperature is below set point.</p> <p>-Display will show “HEATING” and hot water tank temperature</p> <p>The “BREW START” entry buttons will not illuminate until the hot water tank reaches the selected temperature.</p> <p>Controls allow both sides of dual brewer to operate if one side has an ongoing brew started and the second side brew is selected.</p> <p>Notifications shown on screen:</p> <p>TEXT: HEATING→Tank above 87°C/189°F-will allow brew at low temperature.</p> <p>Coffee flavor may be affected</p> <p>TEXT: L. HEAT→Tank above 77°C/170°F-will allow brew at low temperature.</p> <p>Coffee flavor will be noticeably affected</p>	<p>Hot water tank not at brew temp setpoint.</p> <p>Tank temp→</p> <p>STOP is not lit →</p> <p>BREW START buttons not lit. and are disabled.</p> <p>When hot water tank temperature is at setpoint. Buttons will illuminate and “READY” will be displayed</p>
<p>USER SELECTABLE OPTION: BREW AT TEMP: OFF</p> <p>(Not recommended) Unit will operate at lower temperature</p> <p>Allows brewing at any temperature above 77°C/170°F</p> <p>Below 70°C/170°F The brewer will display “HEATING”</p>	

[ft]	[m]	Suggested Setting[°F]	Boiling point[°F]	Suggested Setting[°C]	Boiling point [°C]
0	0	205	212.0	96	100.0
500	152	205	211.0	96	99.5
1000	305	200	210.1	93	98.9
2000	610	200	208.1	93	97.8
2500	762	200	207.2	93	97.3
3000	914	200	206.2	93	96.8
3500	1067	197	205.3	92	96.3
4000	1219	195	204.3	91	95.7
4500	1372	194	203.4	90	95.2
5000	1524	194	202.4	90	94.7
5500	1676	193	201.5	89	94.2
6000	1829	192	200.6	89	93.6
6500	1981	191	199.6	88	93.1
7000	2134	190	198.7	87	92.6
7500	2286	188	197.8	86	92.1
8000	2438	187	196.9	86	91.6
8500	2591	185	196.0	85	91.1



C Service Inputs		Brewer Sensors and Keypad			
POSITION	Program Items	Factory set Default	Programming Range	Increments	Notes
C1	LLC Probe continuity	Direct read	Tank water resistance in TDS	≈850- LOW ≈1600-HIGH	Nominal values
C2	Brew Basket Sensor	L-YES R-YES	YES or NO		
C4	Tank Temperature	Direct read	Hot water tank temperature		Actual values
C5	USB Drive	NO	(not in use)		
C6	Keyboard Test	Calibrate	Checks buttons under membrane cover	YES/NO	Follow directions on the touch screen

D Service Outputs		Test Valves and Heaters; Set screen brightness			
POSITION	Program Items	Factory set Default	Programming Range	Increments	Notes
D1	Heater SSR Test	Press button 2 to test (button 1 stops test)	Activates heater Default is 10 sec..	Toggle +/- OFF or ON	Energizes Heater(s) WARNING! Service use only.
D2	Fill Valve Test	Press button 2 to test (button 1 stops test)	Activates valve Default is 10 sec.	Toggle +/- OFF or ON	Press To Test
D3	LT (left) Brew Valve Test	(Press to test)	Activates valve Default is 10 sec.	Toggle +/- OFF or ON	Runs valve to verify flow. NOTE: Have container under brew basket.
D4	RT (right) Brew Valve Test	(Press to test)	Activates valve Default is 10 sec.	Toggle +/- OFF or ON	Runs valve to verify flow. NOTE: Have container under brew basket.
D5	LT (left) Bypass Valve Test	(Press to test)	Activates valve Default is 10 sec.	Toggle +/- OFF or ON	Runs valve to verify flow. NOTE: Have container under brew basket.
D6	RT (right) Brew Valve Test	(Press to test)	Activates valve Default is 10 sec.	Toggle +/- OFF or ON	Runs valve to verify flow. NOTE: Have container under brew basket.
D7	LT (left) Brew Basket Lock Test	(Press to test)	Activates Brew Basket Lock	Toggle +/- OFF or ON	Press To Test
D8	RT (right) Brew Basket Lock Test	(Press to test)	Activates Brew Basket Lock	Toggle +/- OFF or ON	Press To Test
Single series displays right side only Left Valve display is only for twin side brewer.					
D12	LCD Brightness	Brightness=90%	20-100%	5%	Adjust LCD screen brightness only-Not for LEDs under buttons
D13	LED Brightness	Brightness=60%	20-100%	5%	Adjust LED button brightness only-Not for the screen display LCD



E Calibration		Brewer Sensors and Keypad			
POSITION	Program Items	Factory set Default	Programming Range	Increments	Notes
E1	Ready Temp. Offset	-3°F -2°C	-2° to -9°F -1° to -5° C	1°F 1°C	Compensates output to measured temperature
E2	LLC Sensitivity	NORMAL ("NORMAL" for most water)	HIGH (Biased for reverse osmosis water or very pure water)	NORMAL HIGH	Liquid level control sensitivity. High, 1300Ω is for reverse osmosis water or very pure water.
E3	Slow flow rate from supply	ON	OFF/ON	Toggle +/- YES or NO	Trims fill system for low supply or Flojet use
E4	LT Brew Valve flow rate:	0.95G	0.80-1.09G 1.30-1.90Liter	0.01G 0.05L	Adjusts flow rate
E5	RT Brew Valve flow rate:	0.95G	0.80-1.09G 1.30-1.90Liter	0.01G 0.05L	Adjusts flow rate
E6	LT Bypass Valve flow rate:	0.38G	0.31-0.44G 0.80-1.09Liter	0.01G 0.05L	Adjusts flow rate
E7	RT Bypass Valve flow rate:	0.38G	0.31-0.44G 0.80-1.09Liter	0.01G 0.05L	Adjusts flow rate
E10	Automatic Calibration				

Use this formula to compensate for minor discrepancies in actual volume versus programmed volume.

See "PROGRAM" [E4](#) & [E5](#) For valve settings and calibration. Factory set brew valve flow rates are in liter/min

Current setting is the flow from E4,E5, E6, E7

See table above for factory set default flow rates

$$\frac{\text{ACTUAL VOLUME}}{\text{PROGRAMMED VOLUME}} \times \text{CURRENT SETTING} = \text{NEW SETTING}$$

Use this formula to determine the correct setting

Default Brew Valve Flow Rate—CBS-1250 Brewers

<u>CBS-1250</u>	<u>Gallons/minute</u>	<u>Range</u>
Left Brew Valve FR	0.95	0.80G to 1.09G
Right Brew Valve FR	0.95	0.80G to 1.09G

Set FR lower to increase volume; set higher to decrease volume.

NOTE

Check for these causes for the difference in the programmed value to the brewed value. These must be corrected first.

- CSD spray head is not in place.** This will always result in an increased flow volume
- Flow related error codes 100, 101** - see page 15. Reduced water flow can cause reduced brew volume.
- Clogged or fouled inlet valve or improperly installed inlet valve.** See page 20.
- Verify the screens that the brew time is correct,** and the display is operating as the brew valve may be turning off.
- Lime scale.** This can cause erratic and sometimes random under or over brew volumes. Brew valve can drip, be stuck open or closed, or fail due to lime scale accumulation. Always correct lime scale faults before changing flow rate.

Changing the flow rate corrects the brew volume if it is different from the programmed value.

Flow rate of over and under dispensing is corrected in FLOW RATE Calibration Procedure (E10) on the previous page. The flow rate calibration procedure is an internal program to test for and enter corrections for flow rate inconsistencies. In the procedure: the equipment will dispense for 60 seconds. The quantity of brew water dispensed is carefully measured and entered into the program. The software automatically corrects the flow rate based on the difference of the actual results to the stored values.

The procedure requires a calibrated 1½ gallon/6liter container. The flow must be very accurately measured. It will be easiest to manage the readings if the brewer volume units are placed into ounces or liters for units of measure. [Go to PROGRAM B6]. Units of measure in gallons require a calculation in fractional units of measure - which can be difficult.

TESTING SHOULD BE MADE WITH AN EMPTY BREW BASKET. NO FILTER PAPER. NO COFFEE OR TEA



E10 Calibration Procedure - Automatic

Flow rate calibration is required when the volume dispensed differs significantly and consistently from the brewer setting. This procedure automatically dispenses the selected valve brewer for 60 seconds.

Testing should be performed with an empty brew basket. No filter paper. No coffee or tea

This procedure tests the brew valve and bypass valves (right side or left side).

The quantity dispensed must be very accurately measured. Next: the dispensed quantity is entered into the brewer.

The brewer firmware contains algorithms that automatically adjust the valve flow rate to dispense correctly.

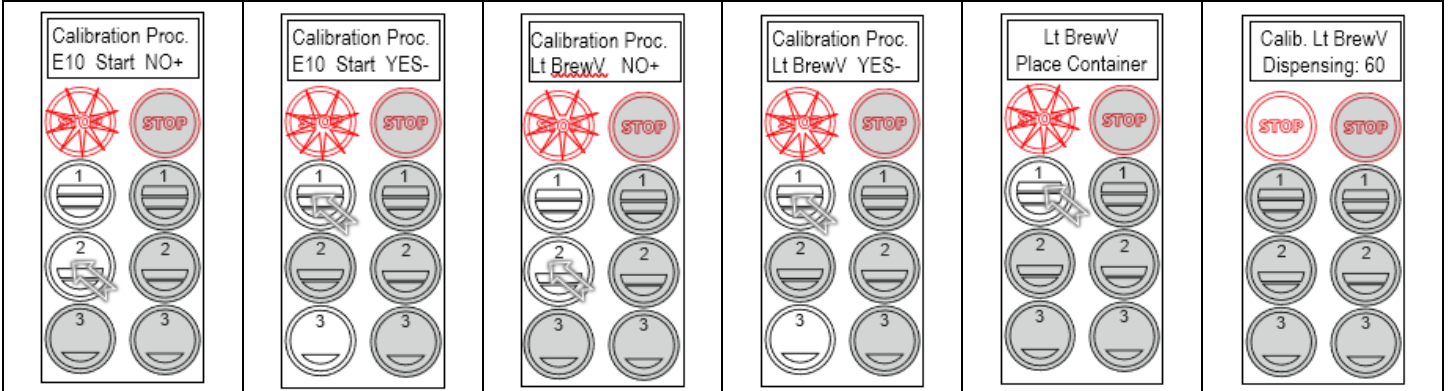

Opening screen
Press button #2 to begin procedure

Confirm calibration
Press button #1 to proceed.
Proceed to next screen to choose which valve to test

Confirm which valve (button 1)
Lt BrewValve;
Rt BrewValve
Lt BypassValve;
Rt BypassValve by toggling top button.
Next: Select & press button 2 to proceed

Press button #1 to Initiate left brew valve calibration

Bottom button halts procedure

Place calibrated 1½ gallon/6liter container under left brew head. (Lt BrewV)
Insert brew basket
Press button #1 to begin testing
*See Note Below ↓

Brewer will dispense for one minute. Screen countdowns.
After drip out stops ...carefully and accurately measure the dispensed quantity of hot water

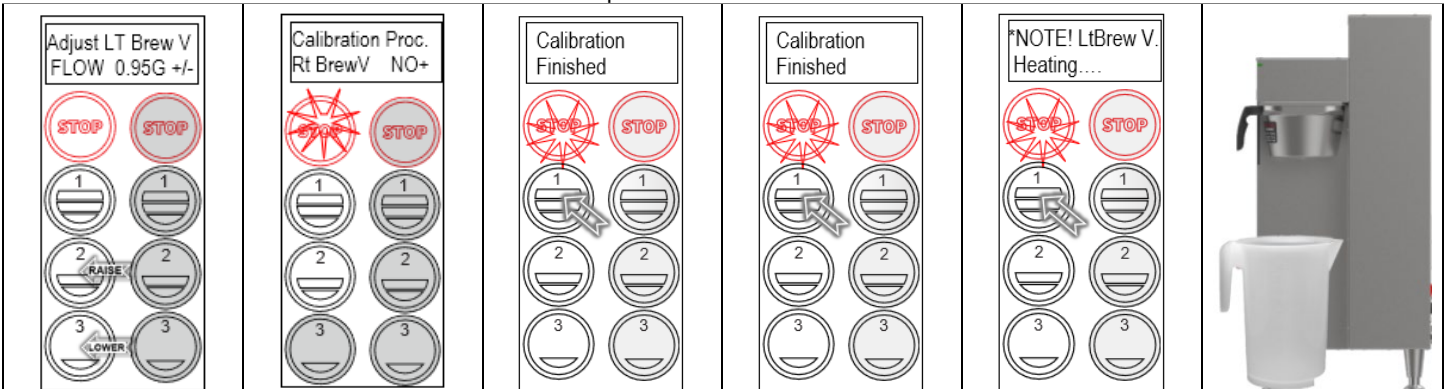

Screen shows current Software then setting.
Enter the exact quantity dispensed by toggling two lower buttons.

Press button #1 when entered

automatically updates the flow rate for the left brew valve
The brewer proceeds to the next valve.

Press button #1 to scroll through valves
Rt BrewValve→
Lt BypassValve→
Rt BypassValve
Last selection is → Calibration Finished

Press STOP to proceed to screen H then: Save & Exit

If hot water tank is not at correct temperature. Calibration holds until temperature is correct.

Brewer will continue when at temperature

Measuring Pitchers:
5 liter graduated Bel-Art catalog F28994-0000
10 liter graduated Bel-Art catalog F28995-0000

Default, factory set, flow rates

Left Brew Valve flow rate: 0.95G Right Brew Valve flow rate: 0.95G
Left Bypass Valve flow rate: 0.38G Right Bypass Valve flow rate: 0.38G

F Service Menu		Software & Code View and Settings			
POSITION	Program Items	Factory set Default	Programming Range	Increments	Notes
F1	Display Firmware	2.2.210720	Displays current version		[6/2020]
F2	Display Bootloader	2.0.210317	Displays current version		[6/2020]
F3	Select Model	CBS-1251;1252;1253 Will need reboot	Scroll to brewer model Save & Exit	CBS-1221 CBS-1251, CBS-1252 CBS-1241, CBS-1242 CBS-1251, CBS-1252 CBS-1261, CBS-1262 MBS-1221, MBS-1251 TBS-1221, MBS-1222	NOTE: Overwrites all user settings (See below)
F4	Option Bypass	Yes	NO or YES		
F5	Option BB Lock	Yes	NO or YES		
F8	Backup to USB	NO	Follow prompts	Saves settings	Insert blank USB
F9	Restore From USB		Applies settings from USB		Insert USB Will need reboot
F10	Restore Defaults	NO	NO/YES		Reset to factory
F11	Error Log	Lists up to six codes, in order	1: ; 2: ;3:;4: ;5: ;6: 1=Newest/6=Oldest LAST six errors only	Newest=first Oldest=last	See p14 Error Codes Chart for references
F12	Erase Error Log	NO +		Toggle +/- YES or NO	FACTORY USE ONLY. DO NOT RESET
F13	Service Phone #	Enter as needed			Set phone contact
F14	Override Lt BBS	NO	NO/YES	Toggle +/- YES or NO	Disables brew basket sensor
F15	Override Rt BBS	NO	NO/YES	Toggle +/- YES or NO	Disables brew basket sensor
F16	Override Lt BBL	NO	NO/YES	Toggle +/- YES or NO	Disables brew basket lock
F17	Override Rt BBL	NO	NO/YES	Toggle +/- YES or NO	Disables brew basket lock



Error Codes (From SERVICE F11 and F12 – Page13)			
DO NOT CLEAR ERROR CODES UNTIL ERROR IS IDENTIFIED AND CORRECTED			
→Contact factory or specialized personnel for error codes			
Code	Description	Possible Cause	Corrective Action
001	Software error-error on start up or corrupted software	Improper start-up or shutdown	Restart, if still fault: reload software
002	Internal flash corrupted internal data memory malfunction	Error found in cyclic redundancy check CRC	Restart, if still fault: reload software If not corrected: replace board
050	Short-circuit in temperature probe	Probe failure.	Replace probe.
051	Open temperature probe.	Bad probe connection, or probe failure.	Check all connections. Replace probe if necessary.
100	Initial Fill Error. Initial fill time took longer than expected after powering up.	Water supply flow rate is too low, fill valve is stuck, water line kinked or closed.	Reboot machine. If persists-investigate cause of low flow rate. (Clogged water filter, kinked line, stuck fill valve)
101	Error on refill. Tank did not refill within expected time.	Water supply flow rate to hot water tank is too low, or fill valve stuck or damaged (SEE PAGE 19)	Check water supply line. Flow should be 20-75 psig, (138-517kPa) >1gal/3.8L/min Investigate cause of low flow rate. If the flow rate is in range-replace fill valve
200	Heating flatline-Tank is boiling	Heater is on, temperature is not rising/dropping	High elevation correction. Bad heaters or temperature probe or position
201	If the hot water tank heaters are turned on during a heating cycle and tank temperature is not increasing according to software logic and the tank temperature is below setpoint	1) Failure of SSR, high limit, temperature probe, or heating element. 2) Water being removed by hot water faucet during heating (control displays "heating")	1)Test and check SSRs, high limit devices temperature probe. Check heating elements with current clamp, replace if necessary. 2)Advise staff to refrain from taking large amounts of water from hot water tank, especially during "heating".
202	Heater Shorted or Stuck SSR	Heater is off and heating SSR is stuck "ON"	Check ohms on heater (15-60Ω). SSR may be stuck in ON mode-replace SSR.
255	Keyboard [HID] error (Human Interface Device)	Usually from longer than 10 seconds' contact. Or faulty reassembly after service	Restart, if still fault: reload software. If mechanical: replace module
NO BSKT <u>Insert Brew Basket</u>		Brew basket must be in place This is a SAFETY FEATURE	Insert brew basket into brewer rails to enable brewer



G Counters Brewer Usage, Water Filter Usage, and Statistics

ROLE: [LT]=Permanent total for lifetime of machine; [R]=operator resettable; [User]=Input needed from operator

Position	Counter	Program items	Role	Information	Increments	Notes
----------	---------	---------------	------	-------------	------------	-------

G1-G4 are for water filter maintenance. All beverage equipment must use filtered water and filter cartridges must be monitored for quality

G4	A, S, B	Counter Reset	[User]	NO	Toggle +/- ,Y or N	Resets all resettable counters to zero
G5	A, S, B	Choose Counter		Factory set to BASIC	Basic= B Advanced= A Statistical= S	Stored brewer component activity.. See column 2, Counters , to identify where counters are located.

G10-G15 Number of brews and volumes handled. Available in BASIC counter only (G5)

G10	B	Brewer Volume	[LT]	Dispensed volume	Gallons/Liters	Total of brews and hot water dispensed
G11	B	Brewer Volume	[R]			
G12	B	Lt Brews	[LT]	Left side brew total CBS-1252	Count	Total brews-Left side (CBS-1252 only)
G13	B	Lt Brews	[R]			
G14	B	Rt Brews	[LT]	Right side brew total CBS-1251&CBS-1252	Count	Total brews-Right side CBS-1251&CBS-1252
G15	B	Rt Brews	[R]			

G20-G55 component use cycles and volumes handled. Available in ADVANCED counter only (G5)

G20	A	Fill Cycles	[LT]	Hot water tank refill cycles	Count	Cycles of hot water tank refill
G21	A	Fill Cycles	[R]			
G22	A	Fill Volume	[LT]	Total volume of water for all brews	Gallons/Liters	Quantity of water for brews
G23	A	Fill Volume	[R]			
G24	A	Lt Brew Cycles	[LT]	Left brew valve operation on/off	Count	Totalized cycles of valve operation (CBS-1252 only)
G25	A	Lt Brew Cycles	[R]			
G26	A	Lt Brew Volume	[LT]	Left brew valve flow through volume	Gallons/Liters	Totalized volume through left valve (CBS-1252 only)
G27	A	Lt Brew Volume	[R]			
G28	A	Rt Brew Cycles	[LT]	Right brew valve operation on/off	Count	Totalized cycles of valve operation CBS-1251&CBS-1252
G29	A	Rt Brew Cycles	[R]			
G30	A	Rt Brew Volume	[LT]	Right brew valve flow through volume	Gallons/Liters	Totalized volume through right valve CBS-1251&CBS-1252
G31	A	Rt Brew Volume	[R]			
G32	A	Lt Bypass Cycles	[LT]	Left bypass valve operation on/off	Count	Totalized cycles of valve operation (CBS-1252 only)
G33	A	Lt Bypass Cycles	[R]			
G34	A	Lt Bypass Volume	[LT]	Left bypass valve flow through volume	Gallons/Liters	Totalized volume through left valve (CBS-1252 only)
G35	A	Lt Bypass Volume	[R]			
G36	A	Rt Bypass Cycles	[LT]	Count	Count	Totalized cycles of valve operation CBS-1251&CBS-1252
G37	A	Rt Bypass Cycles	[R]			
G38	A	Rt Bypass Volume	[LT]	Right bypass valve flow through volume	Gallons/Liters	Totalized volume through right valve CBS-1251&CBS-1252
G39	A	Rt Bypass Volume	[R]			
G48	A	Lt BBL Cycles	[LT]	Left brew basket lock flow through volume	Count	Totalized cycles of brew basket lock operation (CBS-1252 only)
G49	A	Lt BBL Cycles	[R]			
G50	A	Rt BBL Cycles	[LT]	Right brew basket lock operation on/off	Count	Totalized cycles of brew basket lock operation CBS-1251&CBS-1252
G51	A	Rt BBL Cycles	[R]			
G52	A	Heater Cycles	[LT]	ON/OFF switching for heating elements	Count	Totalized cycles of heater switching
G53	A	Heater Cycles	[R]			
G54	A	Heater On Time	[LT]	Total ON time for heating element	Hour	Totalized heater ON time in hours
G55	A	Heater On Time	[R]			

G80-G91 See illustration below for batch button positions Available in STATISTICAL counter only (G5)

G80	S	Batch 10 Cycles	[LT]	Menu button selection and activation count	Count	Total brews-left side top button (CBS-1252 only)
G81	S	Batch 10 Cycles	[R]			
G82	S	Batch 20 Cycles	[LT]	Menu button selection and activation count	Count	Total brews-left side middle button (CBS-1252 only)
G83	S	Batch 20 Cycles	[R]			
G84	S	Batch 30 Cycles	[LT]	Menu button selection and activation count	Count	Total brews-left side bottom button (CBS-1252 only)
G85	S	Batch 30 Cycles	[R]			
G86	S	Batch 40 Cycles	[LT]	Menu button selection and activation count	Count	Total brews-right side top button CBS-1251&CBS-1252
G87	S	Batch 40 Cycles	[R]			
G88	S	Batch 50 Cycles	[LT]	Menu button selection and activation count	Count	Total brews-right side middle button CBS-1251&CBS-1252
G89	S	Batch 50 Cycles	[R]			
G90	S	Batch 60 Cycles	[LT]	Menu button selection and activation count	Count	Total brews-right side bottom button CBS-1251&CBS-1252
G91	S	Batch 60 Cycles	[R]			



The brewer will save changes only from the "H" menu. **DO NOT** reboot brewer or toggle ON/OFF-exit as below.

TO EXIT PROGRAMMING & HOW TO SAVE CONTROL SETTING CHANGES

HOW TO SAVE CHANGES AND EXIT-*The brewer is in PROGRAMMING mode.*

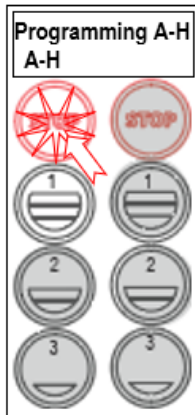

From any screen-
Press STOP button
until the EXIT ("H")
screen appears

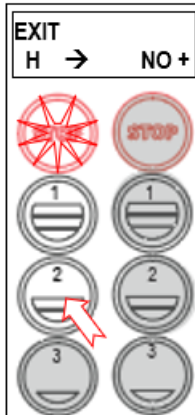

From the "H" screen
Press button **2** to
toggle to the EXIT-
YES screen

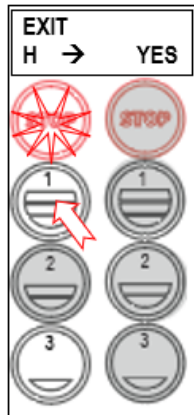

From EXIT screen
Press button **1** to
toggle to the SAVE
screen

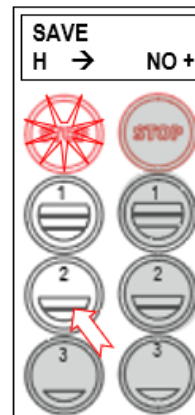

From SAVE screen
Press button **2**, to
toggle to the SAVE-
YES screen

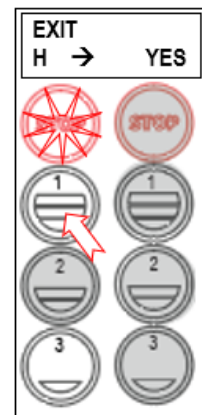

To SAVE and EXIT
Press button **1** to
SAVE your changes
and EXIT

Note: Only the left side buttons of a two sided brewer are used for programming

NOTE: User Settings will be erased and overwritten to factory default settings by the following five programming changes

- 1) When setting or changing units of display for the tank temperature (F Fahrenheit or C Celsius). **(SETTING B4)**
- 2) When setting or changing units of display for the volume (L, G gallons). **(SETTING B5)**
- 3) When setting brewer model →The software sets equipment to brewer defaults **(SETTING F3)**
- 4) When loading from USB (Reprograms settings) **(SETTING F9)**
- 5) When restoring defaults (Reloads to defaults) **(SETTING E10)**

Operator Training

Review the operating procedures with whoever will be using the brewer.

Pay particular attention to the following areas:

1. Always pre-heat the dispensers before the first use of each day by filling them halfway with hot water and letting them stand for at least 5 minutes.
2. Do not remove the brew basket from a coffee brewer until it has stopped dripping.
3. Make sure the dispenser is empty before brewing into it.
4. Show how to attach covers, close, and or secure the dispensers for transporting.
5. Show the location and operation of the water shut off valve as well as the circuit breaker for the brewer.
6. Steam from the tank will form condensation in the vent tubes. This condensation will drip into and then out of the brew baskets. Up to 1/4 cup/118cc discharging overnight is possible. Place an appropriate container under each brew basket when not in use.
7. We recommend leaving the power to the brewer on overnight. The water tank is well insulated and very little electricity is used to keep the tank hot. Leaving the brewer in the "ON" position will also avoid delays at the beginning of shifts for the brewer to reach operating temperature.

Cleaning & Maintenance

After Each Brew:

1. Dispose of grounds and rinse brew basket.
2. Never strike a brew basket or hit it against a hard surface.
This will damage the brew cone, and may damage the brew basket support rails
3. Rinse dispensers before reuse.

Every Day:

1. Wash brew basket with hot sudsy water.
2. Pull CSD from the spray head, it is magnetically attached. Use gloves or a heavy towel. → Wash off any film and reattach. Use vinegar if limescale filming is present.
3. Clean dispensers with hot suds water and a brush, rinse and air dry.
4. Use only a soft cloth and hot suds on the outside to avoid scratches. Never use abrasives that will scratch surface.

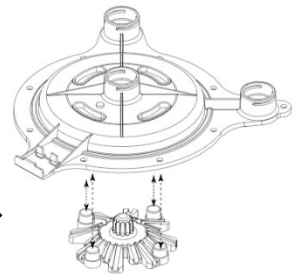

Weekly

1. Use a commercial coffee dispenser cleaner such as URNEX™, TABZ™, DIP-IT™ or Squeak 'n Clean™.
2. Carefully Follow the instructions supplied with the cleaning product
3. Never use spray cleaners, solvent, solvent based cleaner or petroleum based polish anywhere on dispensers

Warning

1. Turn off power before any cleaning procedure, including wiping the exterior for appearance reasons.
2. Dry the exterior, especially the face panel, before turning on power.
3. Do not apply any type of spray cleaner on the face panel of this equipment.
4. Never use solvent or solvent-based cleaner or petroleum based polish anywhere on this equipment.
5. Dry the face of the touch pad before turning on power
6. Do not electrically energize this equipment or attempt operation without all covers in place and all screws fastened.
7. Unplug machine before disassembly or servicing.

Safety Notes

1. Professional installation is required. This appliance is manufactured only for commercial use
2. Operational requirements and maintenance for commercial cooking appliances differ from household appliances.
3. Operators must be trained in this equipment and must understand the use, maintenance and hazards.
4. Access to the service area is restricted to persons having safety/hygiene knowledge and practical experience of the coffee brewer. This appliance must be installed in locations where it can be overseen by adult trained personnel.
5. Do not attempt to move hot beverage equipment once it is filled. Drain equipment before moving.
6. FETCO commercial coffee brewers prepare large amounts of coffee or tea in a single batch using very hot water
7. Commercial coffee brewers provide very hot water from the spray head, brew basket and faucet when it is pulled.
8. Coffee brewers may continue to dispense very hot water from the mechanically operated faucet after the electronic touchpad is completely disabled by turning off the power switch on the lower back of the unit or unplugging the unit.
9. For safety, the brewer control locks the brew basket for 6.0 minutes after starting the brew.
10. Never attempt to defeat the factory set (default) time that the brew basket is locked in safety from start of brew.

Keep these instructions for training and future reference.

General:

1. If not installed correctly by qualified personnel, the brewer will not operate properly, and damage may result.
2. Utilize only qualified beverage equipment service technicians for service and installation.
3. Always have an empty dispenser under spray head of all coffee brewing equipment-including when at idle
4. Damages resulting from improper installation are not covered by the warranty and will void the warranty.
Below are the key points to consider before installation:

Electrical:

1. All CBS Series brewers require **an electrical ground wire**. Installation without grounding is dangerous.
2. Note Equipotentiality Terminal, if present, (To identify the terminals which, when connected together, bring the various parts of equipment or of a system to the same potential, not necessarily being the earth (ground) potential, e.g. for local bonding.)
3. Verify voltages, polarity, circuits, and circuit breaker access before attaching equipment.
4. Brewers in this series wire differently in regard to a neutral wire. Review the wire diagrams.
5. The electrical diagram is located in the User's Guide and online at www.fetco.com.
6. Make sure of the tight grounding of the equipment is tight and use the external ground bolt.
7. The installation must comply with applicable federal, state, and local codes having jurisdiction at your location. Check with your local inspectors to determine what codes will apply.

→See wiring diagrams on pages 29-31 for connections



Plumbing:

1. North America: All installations must comply with applicable federal, state, or local plumbing codes.
2. All Others: The water and waste piping and connections shall comply with the International Plumbing Code, International Code Council (ICC), or to the Uniform Plumbing Code (IAPMO).
3. Install a backflow prevention device. Most municipalities require a recognized backflow preventer
Usable on all hot beverage and cold beverage equipment is a WATTS® SD-2 or SD-3.
WATTS spring loaded double check valve models are accepted by most zoning authorities.
→The check valve should be as close to the water supply inlet of the beverage equipment as possible
4. All beverage equipment must use a water filter. A finishing carbon filter is preferred
5. Install the filter unit after a water shutoff valve and in a position to facilitate filter replacement.
6. The water line and newly installed filter cartridge must be flushed thoroughly prior to connecting it to the brewer to prevent debris from contaminating the machine
7. Verify that the water line will provide a flow rate of at least 1½ gpm/(5.7lpm) per minute and the water pressure is between 20-75 psig (138-517kPa) before making any connections
8. Only use the supplied factory fitting to attach water supply line to brewer (shipped in brew basket)
9. The supplied fitting is a 3/8" flare/compression fitting for 1/4" supply line. Other adaptors may be substituted.
10. Hand tighten the factory fitting when connecting the stub on the brewer. This will reduce stress on the internal connections and reduce the possibility of leaks developing after the install has been completed

Tank Drain

The water tank must be drained before maintenance procedures, and when the unit is to be relocated or shipped. Drain is for service use only and must not be permanently connected. NOTE: Never plumb a water line to the drain.

1. Disconnect power and water to unit. DANGER: Ensure that all utility connections to the brewer are broken.
2. Move the unit near a sink or obtain a container large enough to hold four gallons of water.
→Note: The CBS-1251 hot water tank when full holds 6.5 gallons; the CBS-1252 11.1 gallons.
3. Remove the front panel and tank cover and allow the tank to cool to a safe temperature
4. The tank drain line and clamp are located inside-under the hot water tank. Pinch the drain line clamp to close
5. Locate the fill valve against the back wall, using pliers, loosen the hose clamp and move it back over the tube.
→Note Do not loosen the hose clamp to the bottom of the hot water tank
6. Crimp the tube an inch or two away from the drain plug to prevent water from flowing and pull it off the valve.
7. Pull the tube end out of the brewer and position over sink or bucket.
8. Release the crimped tube and hose clamp and allow the water to flow into the sink or container.
9. Reverse steps 4-8 when service is complete. Ensure pinch clamp is open and hose clamps are in place.

Brewer	Hot Water Tank Capacity	OPEN Leave open for use	
CBS-1251 Single	6.5 gal 24.4 liter	PINCH SHUT To drain tank & service brewer	
CBS-1252 Twin	11.1 gal 42.1 liter		



Brewer Setup

Attach water inlet adapter

Place rubber washer with screen in adapter. Hand tighten only-and 1/4 turn with wrench

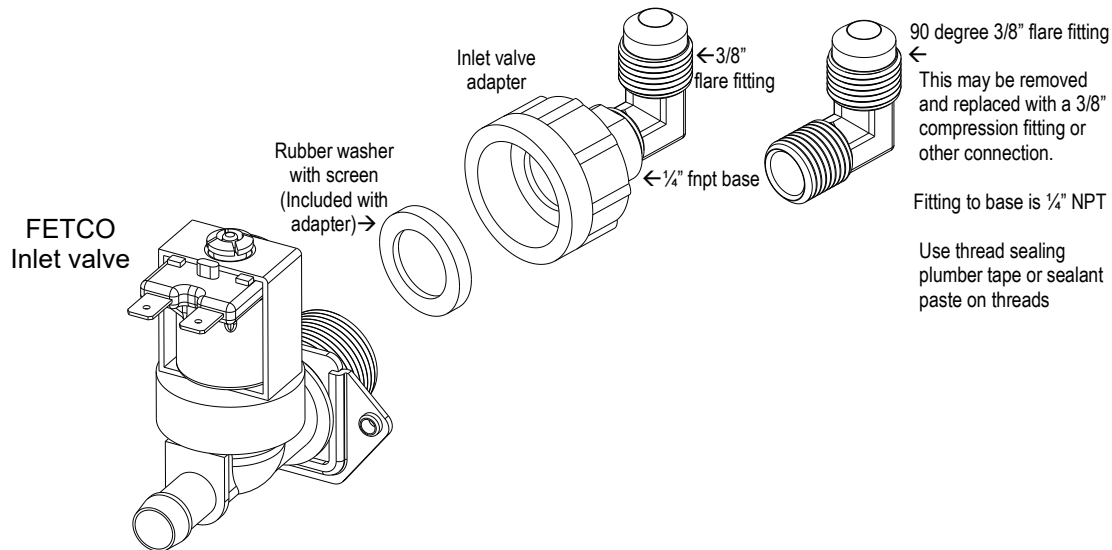

Install the adapter on inlet valve first before attaching water line. Adapter is shipped in the brew basket
The valve threads are 3/4" BSP MALE THREAD and are not 3/4 garden hose fittings.
Use of any other connector to valve will damage the valve
DO NOT use USA dishwasher water adapter or USA washing machine adapter for this connection.
The threads on these USA adapters are unusable for the valve and will damage the valve

TO PREVENT DAMAGE AND INSURE PROPER EQUIPMENT OPERATION

The inlet valve thread is 3/4 INCH BSP (British Standard Pipe).

This valve is not a standard USA washing machine or dishwasher thread (3/4" GHT)

-Use only the plumbing adaptor kit included with this equipment. Use the gasket included in adaptor kit

-Plumber's tape is not recommended for the adapter to valve connection

-Hand tighten adapter on valve with gasket, then very lightly wrench 1/4 turn to set

-DO NOT SUBSTITUTE FITTINGS FOR CONNECTING TO WATER SUPPLY

Damage to inlet valve from improper installation will void the warranty

NOTE: DO NOT TANK PLUMB DRAIN. DRAIN IS FOR SERVICE AND MAINTENANCE.

Notes on Modifying Equipment

!!TO PREVENT SERIOUS DAMAGE TO THE EQUIPMENT, PROPERTY AND INJURY OR DEATH!!

-Do not modify any part of the internal water handling system of any FETCO product.

-Do not modify any part of the electrical system of this equipment including any part of a low voltage DC bus, if present.

-Use only FETCO supplied parts and service methods advised by FETCO. Never substitute with any non-FETCO part.

Only one electrical modification is allowed at the terminal block when installing the brewer to the power utility.

This modification is either to convert the equipment from three-phase to single-phase or, in certain models, to change from the factory-installed 120VAC cord and plug to a 240VAC input.

These specific models are identified by the SKU number on the product label. FETCO offers clear and explicit instructions for modifying wiring from the utility connection, adjusting terminal block wiring, and installing any jumper wires for these models.

Any plumbing or electrical connection or modification must be carried out by a licensed technician.

Installation safety and hygiene directions-For International and CE equipment

1. Access to the service area is restricted to persons having safety/hygiene knowledge and practical experience of the coffee brewer. This appliance must be installed in locations where it can be overseen by trained personnel.
2. For proper operation, this appliance must be installed indoors where the temperature is between 10°C/50°F to 35°C/95°F. Drain and remove all liquid from equipment and lines if exposed to freezing temperatures.
3. All commercial cooking equipment, including this unit, is not intended for use by children or persons with reduced physical, sensory, or mental capabilities. Ensure proper supervision of children and keep them away from the unit.
4. Children should be supervised to ensure that they do not play around hot beverage equipment.
5. This unit must be installed and serviced by qualified personnel only.
6. Installation must conform to all local electrical and plumbing codes. Installation by unqualified personnel will void the unit warranty and may lead to electric shock or burn, as well as damage to unit and/or its surroundings.
7. If the power cord requires repair or replacement-it must be performed by the manufacturer or authorized service personnel with the specified cord only from the manufacturer in order to avoid a hazard.
8. Review the dimensions for the unit and verify that it will fit properly in the space intended for it. Verify that the counter or table will support the total weight of the brewer and dispensers when filled (See: Technical Data).
9. Place the brewer on the counter or stand. When the brewer is in position, level it front to back as well as side-to-side by adjusting the legs.
10. Brewers will need a sturdy supported surface for operation. Do not move brewers when filled.
11. Do not tilt appliance more than 10° to insure safe operation.
12. Unit is for protected indoor use only. Do not steam clean or use excessive water on unit.
13. This unit is not "jet-proof" construction. Do not pressure wash or use jet spray to clean this unit.
14. The unit is not waterproof-do not submerge or saturate with water.

Equipment exposed to flood and contaminated must not be used due to electrical and food safety.

Do not operate if unit has been submerged or

saturated with

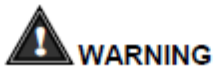

WARNING

All electrical connections must be in accordance with local electrical codes and any other applicable codes. If the supply cord is damaged, it must be replaced by the manufacturer, its service agent, or similarly qualified persons in order to avoid a hazard.

To prevent an electric shock hazard this device must be bonded to equipment in close proximity with an equipotential bonding conductor. This device is equipped with a bonding lug for this purpose and is marked with the following symbol



	WARNING	To reduce risk of electric shock or fire.
	FETCO® Hot Beverage Equipment is for commercial use only.	
	Do not remove or open cover. No user serviceable parts inside. Refer installation and service to qualified personnel.	
	Caution, disconnect from power supply before servicing.	
	GROUND: National Electrical Code requires separate grounding wire.	
	Use dedicated circuit with capacity rated by local code or National Electrical Code for the current draw of this equipment. Check serial number plate on right side for power requirements.	
	Locate unit away from source of heat. Do not install or use near combustibles.	
	THIS APPLIANCE IS ENERGIZED WHENEVER IT IS CONNECTED TO A POWER SOURCE	
	FAILURE TO COMPLY RISKS EQUIPMENT DAMAGE, PROPERTY DAMAGE, FIRE, OR SHOCK HAZARD	
Notice	This equipment must be installed with a backflow protection device to comply with federal, state or local municipality codes.	
Notice	Read the user guide before installing and operating this unit.	

Labels and warnings for hot beverage equipment

For BACK PANEL of equipment (1046.00035.00)

Winterizing equipment

FETCO® equipment should not be exposed to below freezing conditions. Water tank and lines may crack from expansion of freezing water. Commercial kitchen equipment is for indoor use unless rated as IP44 (NEMA-3 equivalent)

Other problems

Live flexible gaskets, tubes and membranes are damaged from freeze/thaw cycles. These elastic materials are compounded for high temperatures and steam contact.

To store or move idle equipment during freezing weather

Have common tools including standard screwdriver set, adjustable wrench, long nose pliers, caps and plugs for disconnected plumbing lines. Also have a wet/dry vacuum set up for wet pickup, flashlight, lock out tags and permanent marking pen.

Perform all brewer and dispenser maintenance prior to shut down.

Sanitize dispensers, drain & dry and if possible store upside down or on sides with lids propped open.

Turn off power. Disconnect brewer from water supply then cap and plug the connectors. Unplug the brewer or disconnect the power.

Open the brewer to access the tank. Open hot water tank cover and drain hot water tank.

After tank is drained, vacuum any moisture out of the hot water tank and brew lines with a new or sanitized hose and tool. Vacuum the hot water service line through the open faucet. Attempt to remove all moisture. Purging with pressurized air is not recommended

At the factory -when preparing for shipping to the customer vacuuming and drying is performed after calibration on a warm brewer. The warm surfaces help dry out moisture.

Inoperative equipment should be tagged. This will assist while it is inactive and at restart.

Unscrew the legs from the bottom if moving equipment

NOTE: Do not use any antifreeze or food safe antifreeze, usually propylene glycol, in this equipment

Descaling equipment

Commercial coffee brewers do not require routine descaling. The water supply mineral content range should be 100-150TDS. This will not contribute to lime scale in normal use.

For water with high mineral content: use a commercial reverse osmosis system to provide the best coffee and tea extraction and provide protection to the equipment from limescale.

A limescale ameliorating water filter, BestMax® or similar, will help control lime formation and protect the brewer if reverse osmosis is not available .

Should the unit need professional descaling: contact the factory for guidance: techsupport@fetco.com

NOTE: Never use muriatic acid, hydrochloric acid, hydrogen chloride solution or descaling compounds containing chlorine. Severe and permanent damage to the metallic components will result and will void the warranty.

Table of Authorities CBS-1250 Plus								
CBS-1251			CBS-1252			CBS-1253		
Item Number	Tank Assembly	Wiring Diagram	Item Number	Tank Assembly	Wiring Diagram	Item Number	Tank Assembly	Wiring Diagram
E1251US-1B230-PM110	1104.00168.00	1401.00196.10	E1252US-UB250-PM110	1104.00163.00	1401.00179.10	E1253US-UB250-PM110	1104.00163.00	1401.00179.10
E1251US-1B230-PM100	1104.00168.00	1401.00196.10	E1252US-UB250-MM110	1104.00163.00	1401.00179.10	E1253US-UB250-MM110	1104.00163.00	1401.00179.10
E1251US-1B230-MM110	1104.00168.00	1401.00196.10	E1252US-UB230-PM110	1104.00160.00	1401.00179.10	E1253US-UB230-PM110	1104.00160.00	1401.00179.10
E1251NM-1B230-PM110	1104.00168.00	1401.00196.10	E1252US-UB230-MM110	1104.00160.00	1401.00179.10	E1253US-UB230-MM110	1104.00160.00	1401.00179.10
E1251KS-1B230-PM110	1104.00168.00	1401.00196.10	E1252NM-UB250-PM110	1104.00163.00	1401.00179.10	E1253NM-UB250-PM110	1104.00163.00	1401.00179.10
E1251IN-1B230-PM110	1104.00168.00	1401.00196.10	E1252NM-1B250-PM110	1104.00164.00	1401.00199.10	E1253NM-1B250-PM110	1104.00164.00	1401.00179.10
E1251IN-1B150-PM110	1104.00166.00	1401.00196.10	E1252KS-3C330-PM110	1104.00160.00	1401.00191.10	E1253IN-3C350-PM110	1104.00163.00	1401.00191.10
E1251IN-1B140-PM110	1104.00165.00	1401.00196.10	E1252IN-3C350-PM110	1104.00163.00	1401.00191.10	E1253IN-3C340-PM110	1104.00162.00	1401.00191.10
E1251CE-1B230-PM110	1104.00168.00	1401.00193.10	E1252IN-3C340-PM110	1104.00162.00	1401.00191.10	E1253IN-3C330-PM110	1104.00160.00	1401.00191.10
E1251CE-1B130-MM005	1104.00210.00	1401.00192.10	E1252IN-3C330-PM110	1104.00160.00	1401.00191.10	E1253IN-1B250-PM110	1104.00164.00	1401.00199.10
E1251BR-1B230-PM110	1104.00168.00	1401.00196.10	E1252IN-1B250-PM110	1104.00164.00	1401.00199.10	E1253IN-1B230-PM110	1104.00161.00	1401.00199.10
			E1252IN-1B230-PM110	1104.00161.00	1401.00199.10	E1253BR-1B250-PM110	1104.00164.00	1401.00199.10
			E1252CE-3C350-PM110	1104.00163.00	1401.00191.10			
			E1252CE-3C330-PM110	1104.00160.00	1401.00191.10			
			E1252BR-1B250-PM110	1104.00164.00	1401.00199.10			



Parts Diagram CBS-1251

Drawing 1101.00572.00
Parts CBS-1251

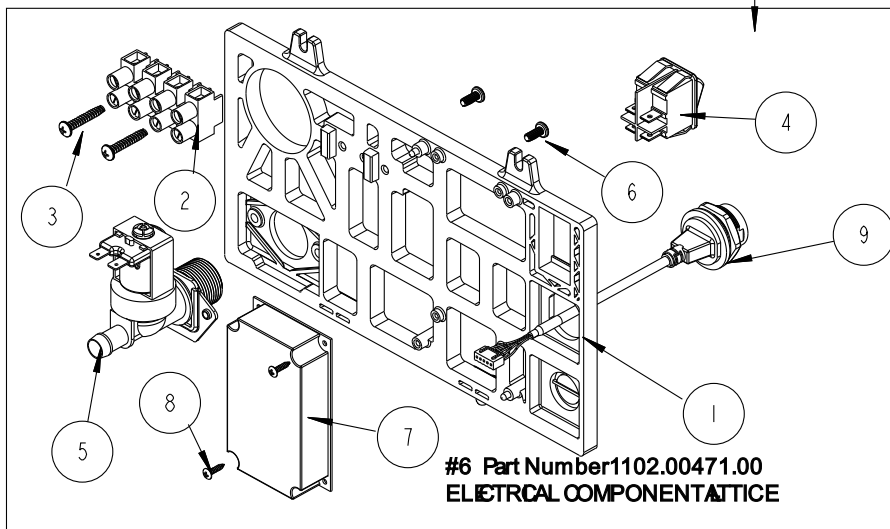
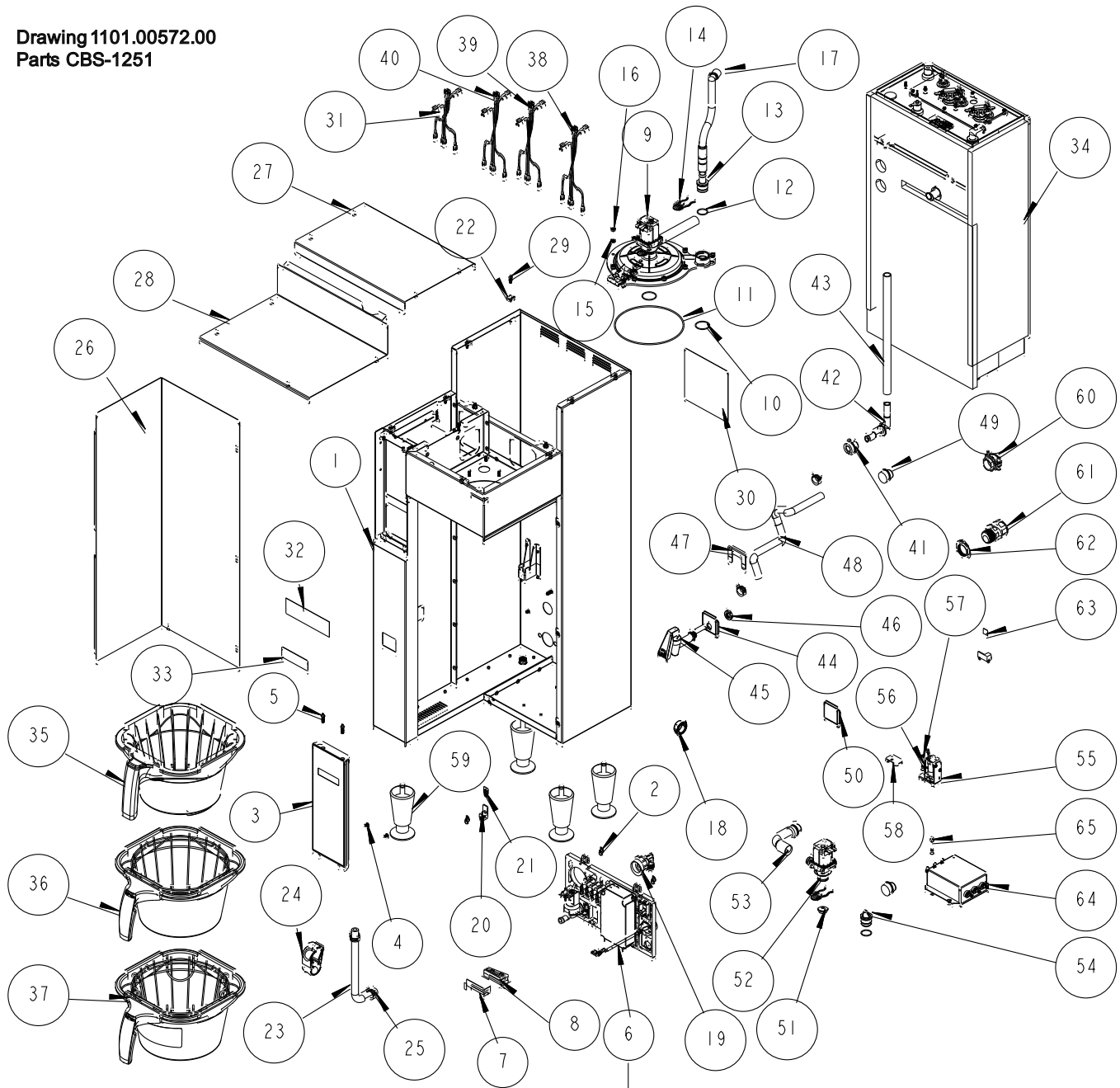

Ref	Qty	Part Number	Description Drawing 1101.00572.00, CBS-1251
1	1	1111.00100.00	WELDMENT BODY, CBS-2251
2	6	1084.00051.00	NUT, HEX LOCKWASHER, #8-32, 18-8 ST. STL
3	1	1102.00480.00	FRONT PANEL ASSY, SINGLE, PLUS SERIES
4	2	1082.00029.00	SCREW, #6 X 3/8 LG, TRUSS HD PHIL, SHEET MTL
5	2	1082.00058.00	SCREW, # 8-32 X 5/8, FLAT HD, PH, 18-8 SS
6	1	1102.00471.00	ELECTRICAL COMPONENT LATTICE, NEXT GEN XV+
6 REF	1	Reference	ELECTRICAL COMPONENT LATTICE, NEXT GEN XV+
6-1	1	1023.00350.00	ELECTRICAL MOUNTING LATTICE, COMMON
6-2	1	1052.00023.00	EUROSTRIP HE16 TERM. BLOCK, 4 POLE, 63 AMP, 18-8 AWG
6-3	2	1082.00056.00	SCREW, # 8-16 x 1" PAN HD PHIL, THREAD FORMING, FOR PLASTICS, 18-8 SS
6-4	2	1058.00024.00	SWITCH, POWER, DOUBLE POLE, 16A, 125/250 VAC
6-5	1	1057.00043.00	SOLENOID VALVE, 5.5L/min, 180 DEG, 24VDC
6-6	2	1082.00010.00	SCREW, PAN HD. PHIL. MACH., M4x10 ZINC-PLATED
6-7	1	1052.00059.00	POWER SUPPLY, 90-264VAC/24VDC, 2.25A
6-8	2	1082.00020.00	SCREW, #6 X 5/8, TRUSS HD PHIL, SHEET MTL
6-9	2	1058.00055.00	USB CONNECTOR
7	1	1097.00171.00	ADHESIVE, RGB LED BAR
8	1	1023.00390.00	LENS, LIGHT BAR, BLACK
9	1	1102.00450.00	QUICK CONNECT SRAYHEAD ASSEMBLY, BASIC [See Page 32 for expanded drawing]
10	2	1024.00107.00	O-RING, 1 3/16" OD X 1 1/16" ID X 1/16" TH, BYPASS SEAL
11	1	1024.00108.00	O-RING, 5 11/16"OD X 5 1/2" ID X 3/32" TH, BREW SEAL
12	2	1024.00106.00	O-RING, 13/16"OD X 11/16"ID X 1/16" TH, FOR QUICK CONNECT
13	1	1023.00343.00	VENT INSERT, QUICK CONNECT
14	2	1023.00342.00	QUICK CONNECT CLIP
15	10	1083.00010.00	WASHER, #10 SCREW W/NEOPRENE-BONDED SEAL
16	10	1084.00006.00	NUT, 8-32 18-8 HEX MACHINE SCREW
17	1	1024.00098.00	VENT TUBE, CBS- EXTRACTOR SERIES
18	1	1086.00004.00	BUSHING, SNAP, 1" MOUNTING HOLE
19	1	1102.00243.00	ADAPTER ASSY, 3/4" BSP x 1/4" NPT x 3/8" TUBE
20	2	1065.00009.00	GROUND LUG CONNECTOR, 14-2 AWG, ALUMINUM
21	1	1044.00012.00	LABEL GROUND, CE
22	12	1084.00011.00	NUT, CLIP ON (J-NUT), #6-32, 22-20 GA., BLK-PH FINISH
23	1	1025.00058.00	TUBE, 9/16"OD X 5/16"ID X 25.00"LG
24	1	1086.00009.00	CLAMP, 3/4" MAX TUBE OD FLOW CONTROL
25	4	1086.00003.00	UNICLAMP, 15.9 HOSE OD CLAMP
26	1	1112.00529.00	WELDMENT FRONT COVER, CBS-2250
27	1	1001.00402.00	COVER TOP, CBS-2251
28	1	1001.00403.00	COVER, UPPER BASE, CBS-2251
29	12	1082.00017.00	SCREW, TRUSS HD. PHIL. MACHINE, # 6-32 X 1/2 LG.
30	1	1046.00035.00	LABEL, WARNING "TO REDUCE RISK OF ELECTRIC SHOCK OR FIRE"
31	1	1402.00097.10	WIRE HARNESS, CBS-1240/50, LOW AMP, UNIVERSAL
32	1	1046.00003.00	LABEL, CSD WARNING, 1.5" X 5.0"
33	1	1041.00033.00	BLACK EXTRACTOR PLUS LABEL, LASER ENGRAVED
34	1	1104.00165.00	TANK ASSEMBLY, CBS-2251, 1 X 4KW/240VAC [See additional pages for expanded drawing]
34	1	1104.00166.00	TANK ASSEMBLY, CBS-2251, 1 X 5KW/240VAC
34	1	1104.00167.00	TANK ASSEMBLY, CBS-2251, 2 X 2.3KW/240VAC
34	1	1104.00168.00	TANK ASSEMBLY, CBS-2251, 2 X 3KW/240VAC
35	1	B015280BN2BK	BREW BASKET ASSY, 16" X 6", 0.280" DIA HOLE, BROWN PLUG
36	1	B001280B1BB	ASSY, 16" X 6", 0.280 DIA HOLE, BLACK
37	1	B002280B1BB	ASSY, 16" X 6", 0.280" DIA HOLE, BLACK-with clips (OPTIONAL)
38	1	1402.00037.10	HARNESS HIGH AMP, CBS-2232/42/51, UL
39	1	1402.00039.10	HARNESS HIGH AMP, CBS-2231/41/51, UL
40	1	1402.00121.10	WIRE HARNESS ADDITION, HIGH AMP, EMI FILTER, 2-POLE, CE
41	1	1024.00111.00	GROMMET, SILICONE, W/ POSITION TABS
42	1	1023.00362.00	FITTING VENT, ELBOW, .375" X .375", SELF POSITIONING
43	1	1013.00131.00	TUBE, 304SS, .625OD X .065 WALL X 11-1/2" LG.
44	1	1023.00348.00	HOT WATER INSERT, MANUAL FAUCET
45	1	1071.00055.00	FAUCET, HOT WATER, PSC-BR-8, WITH FLAT AND STEM
46	1	1084.00048.00	JAM NUT, 1/2-20 UNF, NICKEL PLATED BRASS
47	1	1003.00370.00	HOT WATER INSERT LOCK
48	1	1025.00120.00	TUBE, 9/16"OD X 5/16"ID X 13.00"LG
49	2	1024.00051.00	GROMMET, SILICONE, BLANK
50	1	1023.00349.00	HOT WATER INSERT, NO FAUCET
51	1	1023.00369.00	ORIFICE INSERT, QUICK CONNECT, 3/16" HOLE
52	1	1057.00076.00	VALVE ASSEMBLY, COMPLETE, NG, DELTROL
53	1	1029.00042.00	BYPASS L-TUBE, SILICONE, 2200 SINGLE SERIES
54	1	1023.00344.00	PLUG INSERT, QUICK CONNECT
55	1	1102.00219.00	ASSEMBLY, BB LOCKER, 24VDC
56	6	1083.00009.00	WASHER, #6 SCREW, INTL TOOTH LOCKWASHER
57	2	1084.00010.00	NUT, HEX, #6-32, UNDERSIZED, ZINC PLATED
58	1	1003.00259.00	BRACKET, BREW BASKET LOCK COVER
59	4	1073.00007.00	LEG, FLANGE FOOT, 4" HIGH
60	1	1086.00008.00	CONNECTOR, CLAMP, NON-METALLIC CABLE, 3/4"
61	1	1086.00031.00	SKINTOP, 3/4" NPT, 0.354" - 0.630" DIA CABLE, BLK
62	1	1086.00032.00	LOCKNUT, SKINTOP, 3/4" NPT, BLACK HEX
63	1	1044.00013.00	LABEL EQUIPOTENTIALITY, CE
64	1	1052.00027.00	EMI FILTER, THREE LINE 30A, 250/440VAC
65	4	1084.00012.00	NUT, HEX, #6-32 MACHINE SCREW



Parts Diagrams CBS-1252 and CBS-1253

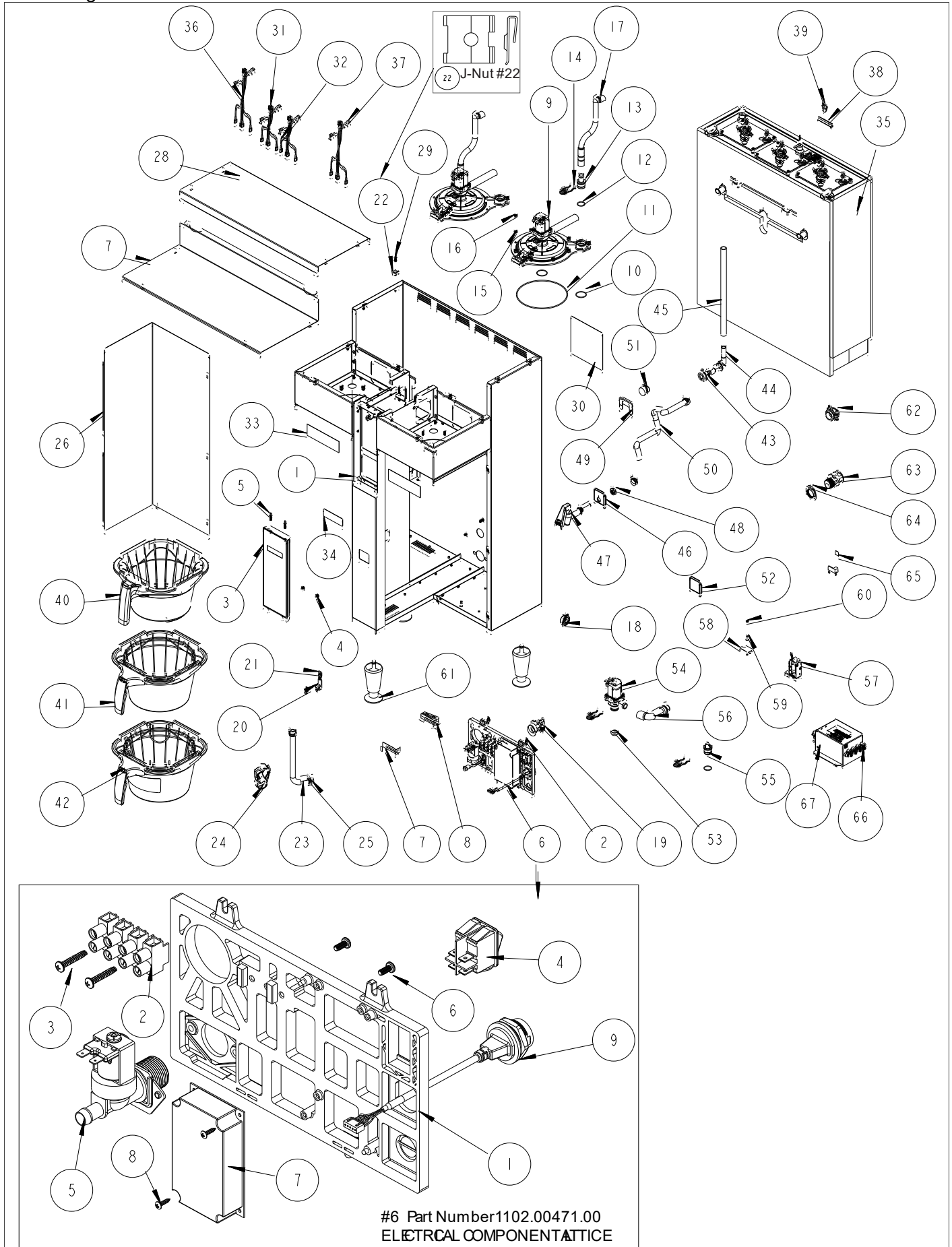

REF	QTY	Part number	Description	Drawing 1101.00573.00, 1101.00059.00 Parts CBS-1252 and applies to CBS-1253
1	1	1111.00099.00	WELDMNT BODY, CBS-2252	1 1/2 gallon brewer only
1	1	1111.00114.00	WELDMNT BODY, CBS-2252	2 gallon brewer only
2	6	1084.00051.00	NUT, HEX LOCKWASHER, #8-32, 18-8 ST. STL.	
3	1	1102.00470.00	FRONT PANEL ASSY, DOUBLE, PLUS SERIES	
4	2	1082.00029.00	SCREW, #6 X 3/8 LG, TRUSS HD PHIL, SHEET MTL	
5	2	1082.00058.00	SCREW, # 8-32 X 5/8, FLAT HD, PH, 18-8 SS	
6 REF	1	Reference	ELECTRICAL COMPONENT LATTICE, NEXT GEN XV+	
6-1	1	1023.00350.00	ELECTRICAL MOUNTING LATTICE, COMMON	
6-2	1	1052.00023.00	EUROSTRIP HE16 TERM. BLOCK, 4 POLE, 63 AMP, 18-8 AWG	
6-3	2	1082.00056.00	SCREW, # 8-16 x 1" PAN HD PHIL, THREAD FORMING, FOR PLASTICS, 18-8 SS	
6-4	2	1058.00024.00	SWITCH, POWER, DOUBLE POLE, 16A, 125/250 VAC	
6-5	4	1057.00043.00	SOLENOID VALVE, 5.5L/min, 180 DEG, 24VDC	
6-6	2	1082.00010.00	SCREW, PAN HD, PHIL. MACH., M4x10 ZINC-PLATED	
6-7	1	1052.00059.00	POWER SUPPLY, 90-264VAC/24VDC, 2.25A	
6-8	2	1082.00020.00	SCREW, #6 X 5/8, TRUSS HD PHIL, SHEET MTL	
6-9	2	1058.00055.00	USB CONNECTOR	
7	1	1097.00171.00	ADHESIVE, RGB LED BAR	
8	1	1023.00390.00	LENS, LIGHT BAR, BLACK	
9	2	1102.00450.00	QUICK CONNECT SRAYHEAD ASSEMBLY, BASIC [See Page 32 for expanded drawing]	
10	4	1024.00107.00	O-RING, 1 3/16" OD X 1 1/16" ID X 1/16" TH, BYPASS SEAL	
11	2	1024.00108.00	O-RING, 5 11/16"OD X 5 1/2" ID X 3/32" TH, BREW SEAL	
12	3	1024.00106.00	O-RING, 13/16"OD X 11/16"ID X 1/16" TH, FOR QUICK CONNECT	
13	2	1023.00343.00	VENT INSERT, QUICK CONNECT	
14	4	1023.00342.00	QUICK CONNECT CLIP	
15	20	1083.00010.00	WASHER, #10 SCREW W/NEOPRENE-BONDED SEAL	
16	20	1084.00006.00	NUT, 8-32 18-8 HEX MACHINE SCREW	
17	2	1024.00098.00	VENT TUBE, CBS- EXTRACTOR SERIES	
18	2	1086.00004.00	BUSHING, SNAP, 1" MOUNTING HOLE	
19	1	1102.00243.00	ADAPTER ASSY, 3/4" BSP x 1/4" NPT x 3/8" TUBE	
20	2	1065.00009.00	GROUND LUG CONNECTOR, 14-2 AWG, ALUMINUM	
21	1	1044.00012.00	LABEL GROUND, CE	
22	12	1084.00011.00	NUT, CLIP ON (J-NUT), #6-32, 22-20 GA., BLK-PH FINISH	
23	1	1025.00058.00	TUBE, 9/16"OD X 5/16"ID X 25.00"LG	
24	1	1086.00009.00	CLAMP, 3/4" MAX TUBE OD FLOW CONTROL	
25	4	1086.00003.00	UNICLAMP, 15.9 HOSE OD CLAMP	
26	1	1112.00529.00	WELDMNT FRONT COVER, CBS-2250	1 1/2 gallon brewer and 2 gallon brewer
27	1	1001.00352.00	COVER, UPPER BASE, CBS-1152 EXTRACTOR V+	
28	1	1001.00399.00	COVER TOP, CBS-2252	
29	12	1082.00017.00	SCREW, TRUSS HD. PHIL. MACHINE, # 6-32 X 1/2 LG.	
30	1	1046.00035.00	LABEL, WARNING "TO REDUCE RISK OF ELECTRIC SHOCK OR FIRE"	
31	1	1402.00097.10	WIRE HARNESS, CBS-1240/50, LOW AMP, UNIVERSAL	
32	1	1402.00097.11	WIRE HARNESS ADDITION, CBS-1252, LOW AMP, UNIVERSAL	
33	2	1046.00003.00	LABEL, CSD WARNING, 1.5" X 5.0"	
34	1	1041.00033.00	BLACK EXTRACTOR PLUS LABEL, LASER ENGRAVED	
35	1	1104.00160.00	TANK ASSEMBLY, CBS-2252, 3 X 3KW/240VAC	[See additional pages for expanded drawing]
35	1	1104.00161.00	TANK ASSEMBLY, CBS-2252, 2 X 3KW/240VAC	[See additional pages for expanded drawing]
35	1	1104.00162.00	TANK ASSEMBLY, CBS-2252, 3 X 4KW/240VAC	[See additional pages for expanded drawing]
35	1	1104.00163.00	TANK ASSEMBLY, CBS-2252, 3 X 5KW/240VAC	[See additional pages for expanded drawing]
35	1	1104.00164.00	TANK ASSEMBLY, CBS-2252, 2 X 5KW/240VAC	[See additional pages for expanded drawing]
36	1	1402.00112.10	WIRE HARNESS, CBS-1252/61, HIGH AMP, 1 OR 3PH, 3 HEATERS, UL	
37	1	1402.00120.10	WIRE HARNESS, 3 HEATER, HIGH AMP, 3L-N-PE, 220/380-240/415, INTL/CE	
38	1	1022.00032.00	SLEEVE, Ø.50 x 2.0" LG. x 1.50" SLOT	
39	1	1066.00003.00	CABLE TIE, 3-7/8" LG., BLACK	
40	1	B015280BN2BK	BREW BASKET ASSY BLACK, 16" X 6", 0.280" DIA HOLE, BROWN PLUG	
41	1	B001280B1BB	ASSY, 16" X 6", 0.280 DIA HOLE, BLACK	
42	1	B002280B1BB	ASSY, 16" X 6", 0.280" DIA HOLE, BLACK	
43	1	1024.00111.00	GROMMET, SILICONE, W/ POSITION TABS	
44	1	1023.00362.00	FITTING VENT, ELBOW, .375" X .375", SELF POSITIONING	
45	1	1013.00131.00	TUBE, 304SS, .625OD X .065 WALL X 11-1/2" LG.	
46	1	1023.00348.00	HOT WATER INSERT, MANUAL FAUCET	
47	1	1071.00055.00	FAUCET, HOT WATER, PSC-BR-8, WITH FLAT AND STEM	
48	1	1084.00048.00	JAM NUT, 1/2-20 UNF, NICKEL PLATED BRASS	
49	1	1003.00370.00	HOT WATER INSERT LOCK	
50	1	1025.00120.00	TUBE, 9/16"OD X 5/16"ID X 13.00"LG	
51	1	1024.00051.00	GROMMET, SILICONE, BLANK	
52	1	1023.00349.00	HOT WATER INSERT, NO FAUCET	
53	1	1023.00369.00	ORIFICE INSERT, QUICK CONNECT, 3/16" HOLE	
54	1	1057.00076.00	VALVE ASSEMBLY, COMPLETE, NG, DELTROL	
55	1	1023.00344.00	PLUG INSERT, QUICK CONNECT	
56	1	1029.00042.00	BYPASS L-TUBE, SILICONE, 2200 SINGLE SERIES	
57	1	1102.00219.00	ASSEMBLY, BB LOCKER, 24VDC	
58	1	1003.00259.00	BRACKET, BREW BASKET LOCK COVER	
59	2	1083.00009.00	WASHER, #6 SCREW, INTL TOOTH LOCKWASHER	
60	1	1084.00010.00	NUT, HEX, #6-32, UNDERSIZED, ZINC PLATED	
61	3	1073.00007.00	LEG, FLANGE FOOT, 4" HIGH	
62	1	1086.00008.00	CONNECTOR, CLAMP, NON-METALLIC CABLE, 3/4"	
63	1	1086.00031.00	SKINTOP, 3/4" NPT, 0.354" - 0.630" DIA CABLE, BLK	
64	1	1086.00032.00	LOCKNUT, SKINTOP, 3/4" NPT, BLACK HEX	
65	1	1044.00013.00	LABEL EQUIPOTENTIALITY, CE	
66	1	1052.00050.00	EMI FILTER, 25A, 250/440VAC, 50/60Hz	
67	1	1084.00012.00	NUT, HEX, #6-32 MACHINE SCREW	



CBS-1251 Tank Assembly

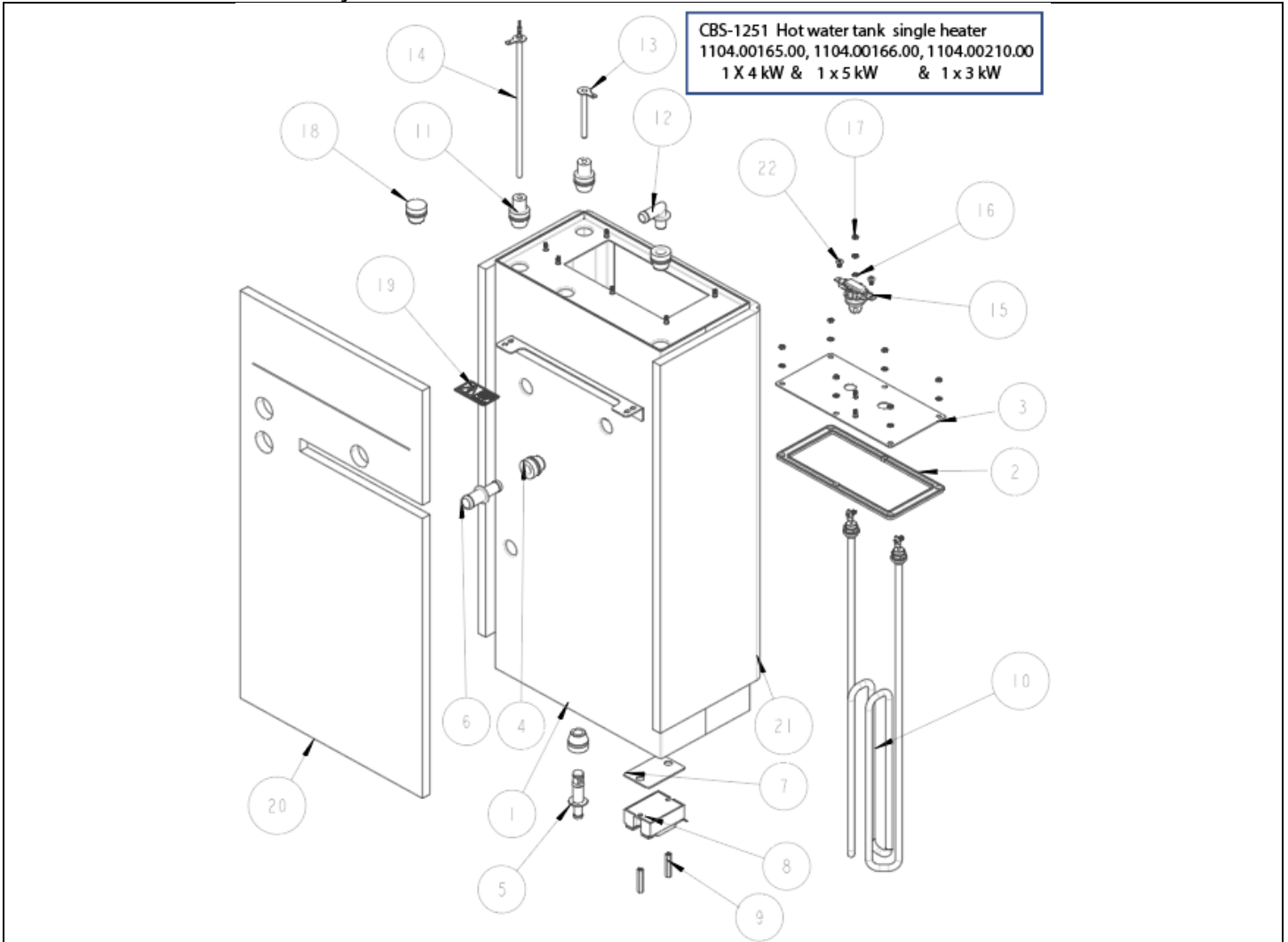

TANK ASSY, CBS-1251 Single Heater Drawing number 1104.000165.00 & 1104.000166.00 1104.000210.00

REF	QTY	Part number	Description
1	1	1114.00172.00	WELDMENT, TANK, CBS-2251
2	1	1024.00114.00	TANK GASKET - NG HEATER PLATE, TWO ELEMENT
3	1	1114.00184.00	WELDMENT TANK HEATER BRACKET, NG-2231, SINGLE
4	3	1024.00050.00	GROMMET, SILICONE, 11.4mm ID
5	1	1023.00166.00	FITTING, COLD WATER INLET, GROMMET DESIGN
6	1	1023.00203.00	FITTING, STRAIGHT, GROMMET, .625"
7	1	1003.00140.00	ALUMINUM BRACKET FOR SSR
8	1	1052.00033.00	RELAY, SOLID STATE, 50A/480VAC, W/BUILD IN VARISTOR
9	2	1081.00042.00	STANDOFF, 1/4" HEX
10	1	1107.00005.00	HEATER ASSEMBLY, IMMERSION 3kW/240VAC (for tank # 1104.000210.00)
10	1	1107.00010.00	HEATER ASSEMBLY, IMMERSION 4kW/240VAC (for tank # 1104.00165.00)
10	1	1107.00032.00	HEATER ASSEMBLY, IMMERSION, 5kW/240VAC (for tank # 1104.00166.00)
11	2	1024.00053.00	LEVEL AND TEMP PROBE GROMMET
12	1	1023.00212.00"	FITTING, ELBOW, GROMMET, .500
13	1	1112.00019.00	PROBE WELDMENT, WATER LEVEL 2.600" LG
14	1	1102.00161.00	PROBE ASSEMBLY, TEMP. AND LLC, 8" LONG
15	1	1053.00052.00	THERMOSTAT, SINGLE SHOT, SCREW CONNECTIONS, 240V/25A
16	8	1083.00009.00	WASHER, #6 SCREW, INTL TOOTH LOCKWASHER
17	8	1084.00010.00	NUT, HEX, #6-32, UNDERSIZED, ZINC PLATED
18	1	1044.00004.00	LABEL, DANGER, HIGH VOLTAGE
19	1	1024.00051.00	GROMMET, SILICONE, BLANK
20	1	1022.00068.00	INSULATION, TANK FRONT, CBS-2151
21	1	1022.00069.00	INSULATION, TANK BACK, CBS-2151
22	2	1082.00136.00	BRASS SCREW, #8-32 X 1/4", PHILLIPS PAN HEAD



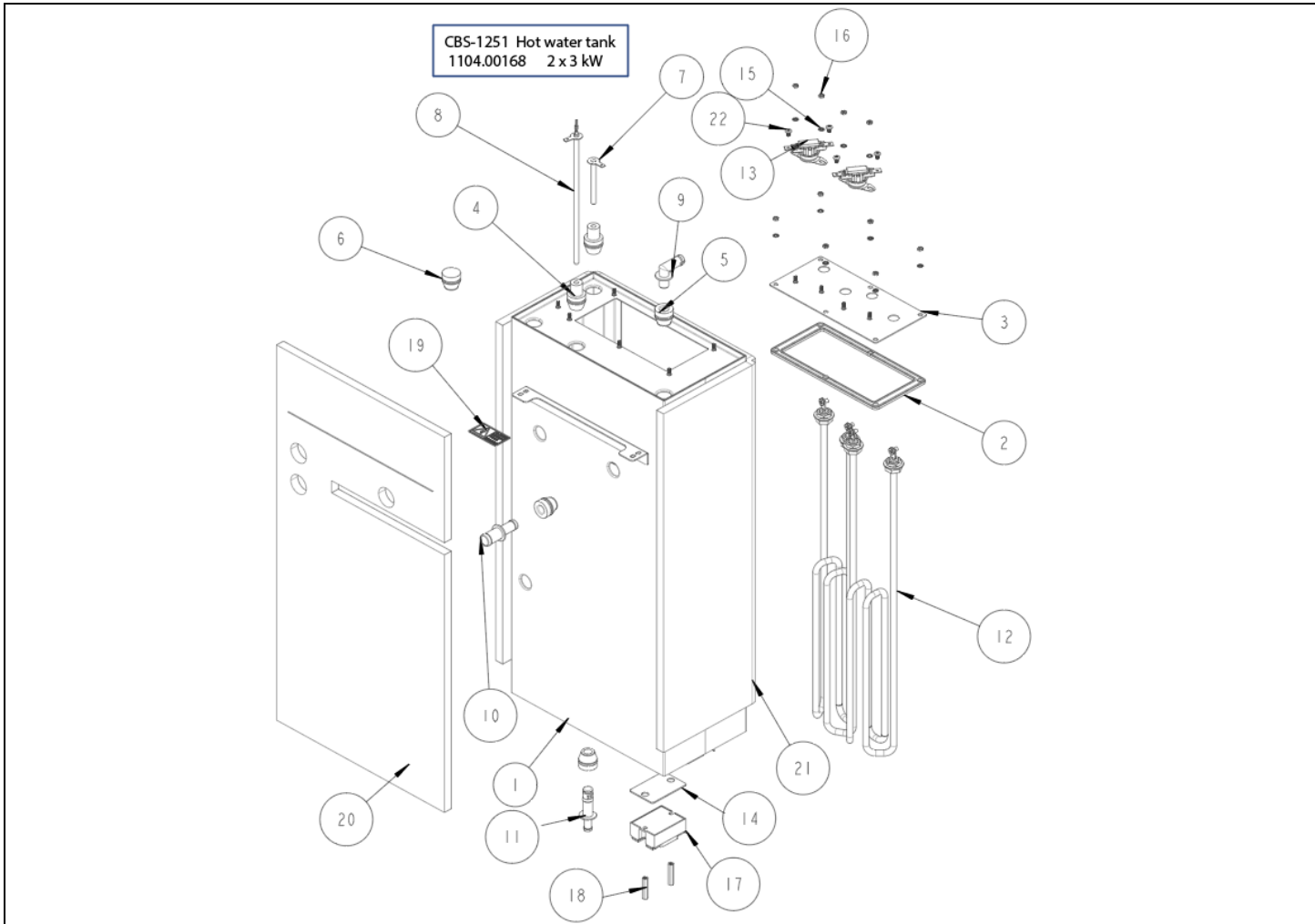

TANK ASSY, CBS-1251 Two Heater Drawing number 1104.000167.00 & 1104.00168.00

REF	QTY	Part number	Description
1	1	1114.00172.00	WELDMENT, TANK, CBS-2251
2	1	1024.00114.00	TANK GASKET - NG HEATER PLATE, TWO ELEMENT
3	1	1114.00176.00	WELDMENT TANK HEATER BRACKET, NG-2231
4	3	1024.00050.00	GROMMET, SILICONE, 11.4mm ID
5	1	1023.00166.00	FITTING, COLD WATER INLET, GROMMET DESIGN
6	1	1023.00203.00	FITTING, STRAIGHT, GROMMET, .625"
7	2	1003.00140.00	ALUMINUM BRACKET FOR SSR
8	2	1052.00033.00	RELAY, SOLID STATE, 50A/480VAC, W/BUILD IN VARISTOR
9	4	1081.00042.00	STANDOFF, 1/4" HEX
10	2	1107.00037.00	HEATER ASSEMBLY, IMMERSION 2300W/240VAC
10	2	1107.00005.00	HEATER ASSEMBLY, IMMERSION 3000W/240VAC
11	2	1024.00053.00	LEVEL AND TEMP PROBE GROMMET
12	1	1023.00212.00	FITTING, ELBOW, GROMMET, .500"
13	1	1112.00019.00	PROBE WELDMENT, WATER LEVEL 2.600" LG
14	1	1102.00161.00	PROBE ASSEMBLY, TEMP. AND LLC, 8" LONG
15	2	1053.00052.00	THERMOSTAT, SINGLE SHOT, SCREW CONNECTIONS, 240V/25A
16	10	1083.00009.00	WASHER, #6 SCREW , INTL TOOTH LOCKWASHER
17	10	1084.00010.00	NUT, HEX, #6-32, UNDERSIZED, ZINC PLATED
18	1	1024.00051.00	GROMMET, SILICONE, BLANK
19	1	1044.00004.00	LABEL, DANGER, HIGH VOLTAGE
20	1	1022.00068.00	INSULATION, TANK FRONT, CBS-2151
21	1	1022.00069.00	INSULATION, TANK BACK, CBS-2151
22	4	1082.00136.00	BRASS SCREW, #8-32 X 1/4", PHILLIPS PAN HEAD

CBS-1252 and CBS1253 Tank Assembly

CBS-1252 Hot water tank
 1104.00161.00; 1104.00164.00
 2 X 3kW; 2x 5 kW

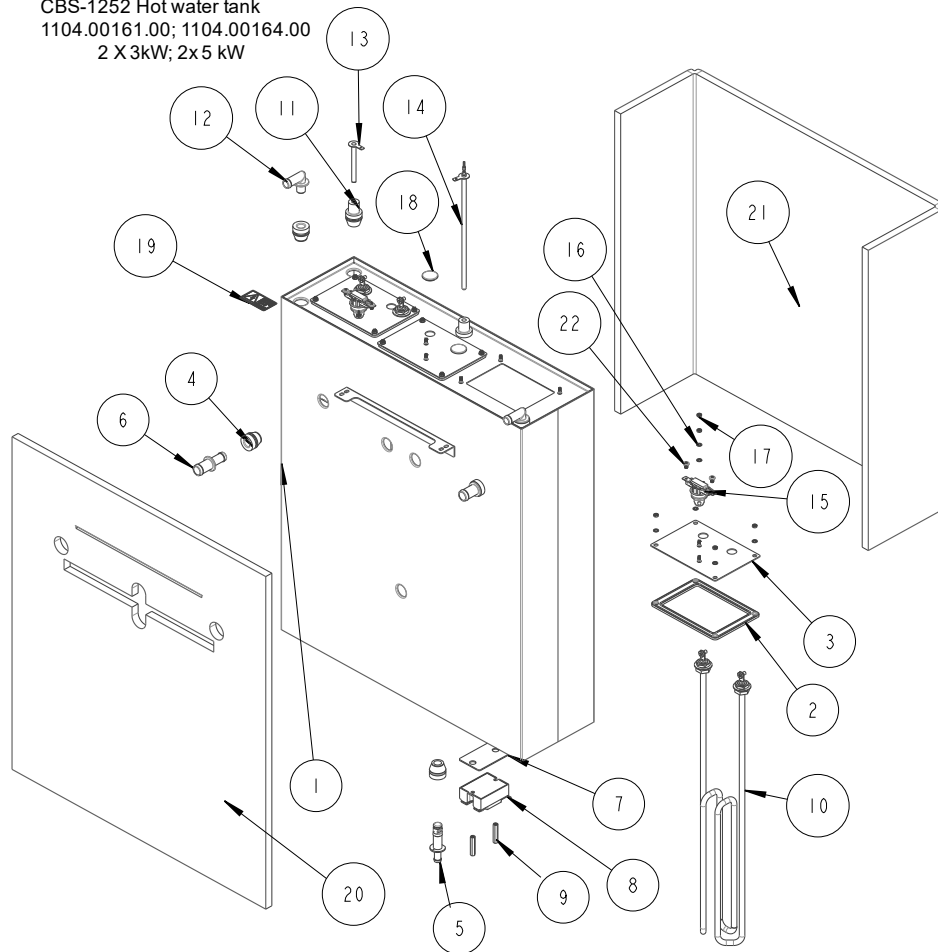

CBS-1252 Hot Water Tank Drawing 1104.00161.00 & 1104.00164.00

Ref#	Qty	Part number	Description
1	1	1114.00164.00	WELDMENT TANK, CBS-2252, LASER
2	3	1024.00115.00	TANK GASKET - NG HEATER PLATE, ONE ELEMENT
3	3	1114.00181.00	WELDMENT TANK HEATER BRACKET, NG-2232
4	5	1024.00050.00	GROMMET, SILICONE, 11.4mm ID
5	1	1023.00166.00	FITTING, COLD WATER INLET, GROMMET DESIGN
6	2	1023.00203.00	FITTING, STRAIGHT, GROMMET, .625"
7	2	1003.00140.00	ALUMINUM BRACKET FOR SSR
8	2	1052.00033.00	RELAY, SOLID STATE, 50A/480VAC, W/BUILD IN VARISTOR
9	4	1081.00042.00	STANDOFF, 1/4" HEX
10	2	1107.00005.00	ASSEMBLY, IMMERSION HEATER, 3000W, 240VAC
10	2	1107.00032.00	ASSEMBLY, IMMERSION HEATER, 5000W, 240VAC
11	2	1024.00053.00	LEVEL AND TEMP PROBE GROMMET
12	2	1023.00212.00	FITTING, ELBOW, GROMMET, .500"
13	1	1112.00019.00	PROBE WELDMENT, WATER LEVEL 2.600" LG
14	1	1102.00161.00	PROBE ASSEMBLY, TEMP. AND LLC, 8" LONG
15	2	1053.00052.00	THERMOSTAT, SINGLE SHOT, SCREW CONNECTIONS, 240V/25A
16	16	1083.00009.00	WASHER, #6 SCREW , INTL TOOTH LOCKWASHER
17	16	1084.00010.00	NUT, HEX, #6-32, UNDERSIZED, ZINC PLATED
18	2	1024.00054.00	GROMMET, SILICONE PLUG
19	1	1044.00004.00	LABEL, DANGER, HIGH VOLTAGE
20	1	1022.00070.00	INSULATION, TANK FRONT, CBS-2152
21	1	1022.00071.00	INSULATION, TANK BACK, CBS-2152
22	4	1082.00136.00	BRASS SCREW, #8-32 X 1/4", PHILLIPS PAN HEAD

CBS-1252 Hot water tank
 1104.00160.00; 1104.00162.00; 1104.00163.00
 3 X 3kW; 3 X 4 kW & 3 x 5 kW

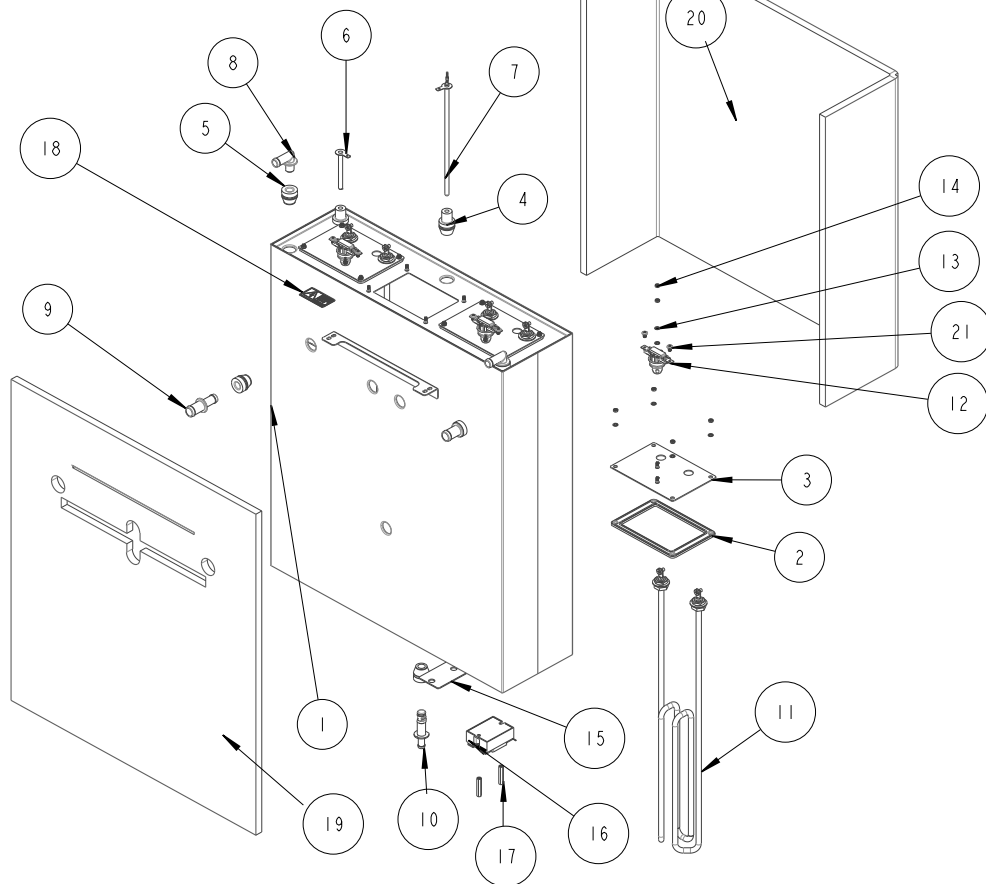

CBS-1252 and CBS-1253 Hot Water Tank Drawing 1104.00160.00; 1104.00162.00; 1104.00163.00

Ref#	Qty	Part number	Description
1	1	1114.00164.00	WELDMENT TANK, CBS-2252, LASER
2	3	1024.00115.00	TANK GASKET - NG HEATER PLATE, ONE ELEMENT
3	3	1114.00181.00	WELDMENT TANK HEATER BRACKET, NG-2232
4	2	1024.00053.00	LEVEL AND TEMP PROBE GROMMET
5	5	1024.00050.00	GROMMET, SILICONE, 11.4mm ID
6	1	1112.00019.00	PROBE WELDMENT, WATER LEVEL 2.600" LG
7	1	1102.00161.00	PROBE ASSEMBLY, TEMP. AND LLC, 8" LONG
8	2	1023.00212.00	FITTING, ELBOW, GROMMET, .500"
9	2	1023.00203.00	FITTING, STRAIGHT, GROMMET, .625"
10	1	1023.00166.00	FITTING, COLD WATER INLET, GROMMET DESIGN
11	3	1107.00005.00	ASSEMBLY, IMMERSION HEATER, 3000W, 240VAC
11	3	1107.00010.00	ASSEMBLY, IMMERSION HEATER, 4000W, 240VAC
11	3	1107.00032.00	ASSEMBLY, IMMERSION HEATER, 5000W, 240VAC
12	3	1053.00052.00	THERMOSTAT, SINGLE SHOT, SCREW CONNECTIONS, 240V/25A,
13	18	1083.00009.00	WASHER, #6 SCREW , INTL TOOTH LOCKWASHER
14	18	1084.00010.00	NUT, HEX, #6-32, UNDERSIZED, ZINC PLATED
15	3	1003.00140.00	ALUMINUM BRACKET FOR SSR
16	3	1052.00033.00	RELAY, SOLID STATE, 50A/480VAC, W/BUILD IN VARISTOR
17	6	1081.00042.00	STANDOFF, 1/4" HEX
18	1	1044.00004.00	LABEL, DANGER, HIGH VOLTAGE
19	1	1022.00070.00	INSULATION, TANK FRONT, CBS-2152
20	1	1022.00071.00	INSULATION, TANK BACK, CBS-2152
21	6	1082.00136.00	BRASS SCREW, #8-32 X 1/4", PHILLIPS PAN HEAD

Standard Plastic Brew Basket Part Number B015280BN2BK 0.280" diameter hole

Brew basket handle plug for polymeric brew baskets is available in optional colors.

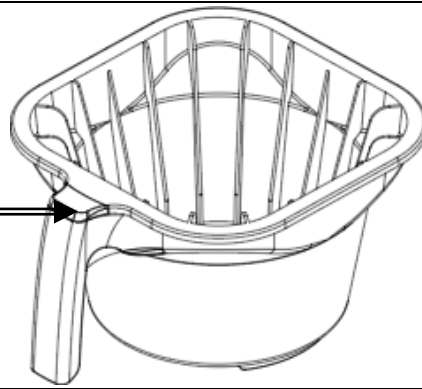

Part Number	Plug Insert color
1023.00195.00	BROWN PLUG, BB HANDLE
1023.00194.00	BLACK PLUG, BB HANDLE
1023.00190.00	RED PLUG, BB HANDLE
1023.00191.00	GREEN PLUG, BB HANDLE
1023.00192.00	ORANGE PLUG, BB HANDLE
1023.00180.00	BLUE PLUG, BB HANDLE

Standard Stainless Steel Brew Basket

Ref#	Part Number	Description
←	B001280B1	Complete Stainless Steel Brew basket <u>no clips</u> (Standard)
	B002280B1	Complete Stainless Steel Brew basket <u>with clips</u> (Optional)
1	1112.00058.00	BB brew cone WLDMNT
2	1046.00025.00	BREW BASKET WARNING LABEL
3	1082.00040.00	SCREW, 1/4-20 X .5, FL HD, PH., W/NYLN
4	1009.00005.00	WIRE BASKET
5	1102.00064.00	HANDLE W/MAGNET ASY, BLACK
6	1009.00003.00	CLIP, WIRE BASKET, NOTE! Requires 4 clips
Optional colored handle	1102.00065.00	HANDLE W/MAGNET ASY, RED
Optional colored handle	1102.00066.00	HANDLE W/MAGNET ASY, GREEN
Optional colored handle	1102.00067.00	HANDLE W/MAGNET ASY, ORANGE

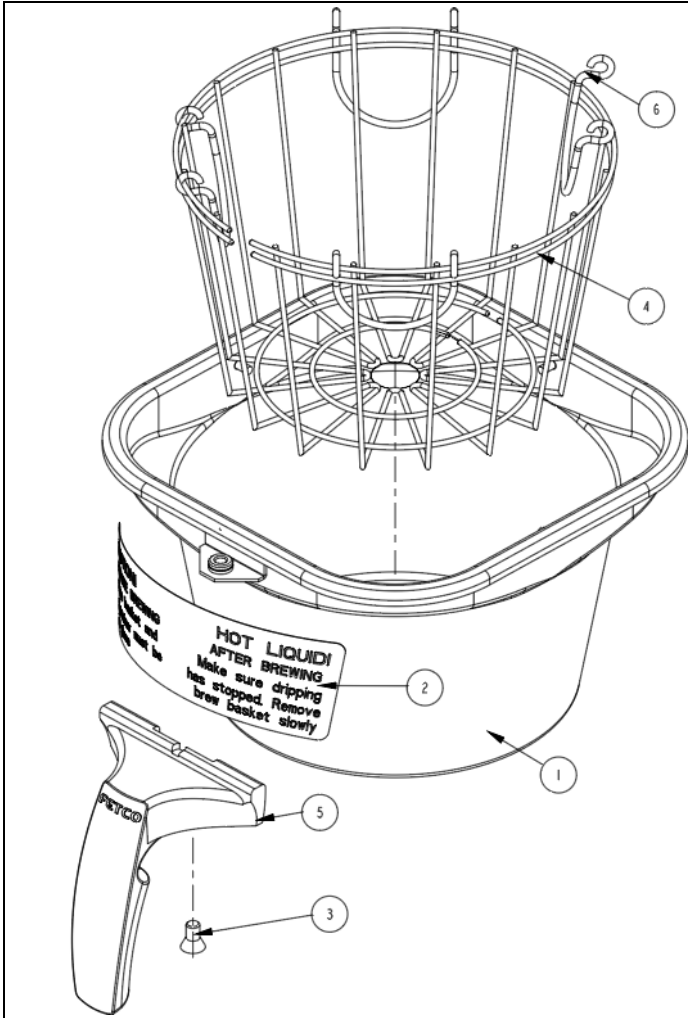

Specialty Brew Baskets for Iced Tea/Tea and Specialty Coffee Brewing.

Below are brew baskets with expanded or reduced orifice sizes. Changing the brew basket orifice diameter may require changing brew time and pulses to enhance extraction and prevent basket overflow or short potting..

See Page 7&8 to modify the brew recipes

Stainless Steel Brew Baskets

16" X 6" for 1 ½ gallon and 2 gallon brewers. Use 15" X 5 ½" filter paper for all models

Part Number	Handle Color	Orifice diameter
B001280B1* Standard NO CLIPS	BLACK - STANDARD	0.280" STANDARD
B002280B1 WITH CLIPS	BLACK -	0.280
B001280R1 NO CLIPS	RED	0.280
B002280R1 WITH CLIPS	RED	0.280
B001280O1 NO CLIPS	ORANGE	0.280
B002280O1 WITH CLIPS	ORANGE	0.280
B001280G1 NO CLIPS	GREEN	0.280
B002280G1 WITH CLIPS	GREEN	0.280
B001280B1L ("COFFEE" label on basket)	BLACK -	0.280"
b001206b1("ICED TEA" label on basket)	BLACK -	0.206 REDUCED
B001280B1	BLACK -	0.158"/4mm REDUCED
B001110G1 ("ICED TEA" label on basket)	GREEN	0.110 REDUCED
b001110b1 ("ICED TEA" label on basket)	BLACK -	0.110 REDUCED

Colored handles for stainless steel brew baskets

1102.00065.00	Complete Handle W/Magnet RED
1102.00066.00	Complete Handle W/Magnet GREEN
1102.00066.00	Complete Handle W/Magnet ORANGE

Plastic Brew Baskets

16" X 6" for 1 ½ gallon and 2 gallon brewers. Use 15" X 5 ½" filter paper for all models

Colored plugs available for handle as identifier

Part Number	Handle PLUG color	Orifice diameter
B015280BN2BK* – Black Body	Brown - STANDARD	0.280" STANDARD
B015280R2BK – Black Body	RED	0.280
B015280BN2 – Brown Body	Brown	0.280
b015158bn2 – Dark Grey Body	Brown	0.158"/4mm REDUCED
b015140g2bk – Black Body	Green	0.140" orifice REDUCED

Below are colored plugs that fit the handle of plastic brew baskets. This helps to quickly identify the basket.

Note that the plugs only fit plastic brew baskets. Colored handles are available for stainless steel brew baskets,

Part Number	Plug Insert color
1023.00195.00	BROWN PLUG, BB HANDLE
1023.00194.00	BLACK PLUG, BB HANDLE
1023.00190.00	RED PLUG, BB HANDLE
1023.00191.00	GREEN PLUG, BB HANDLE
1023.00192.00	ORANGE PLUG, BB HANDLE
1023.00180.00	BLUE PLUG, BB HANDLE



Quick connect spray head assembly

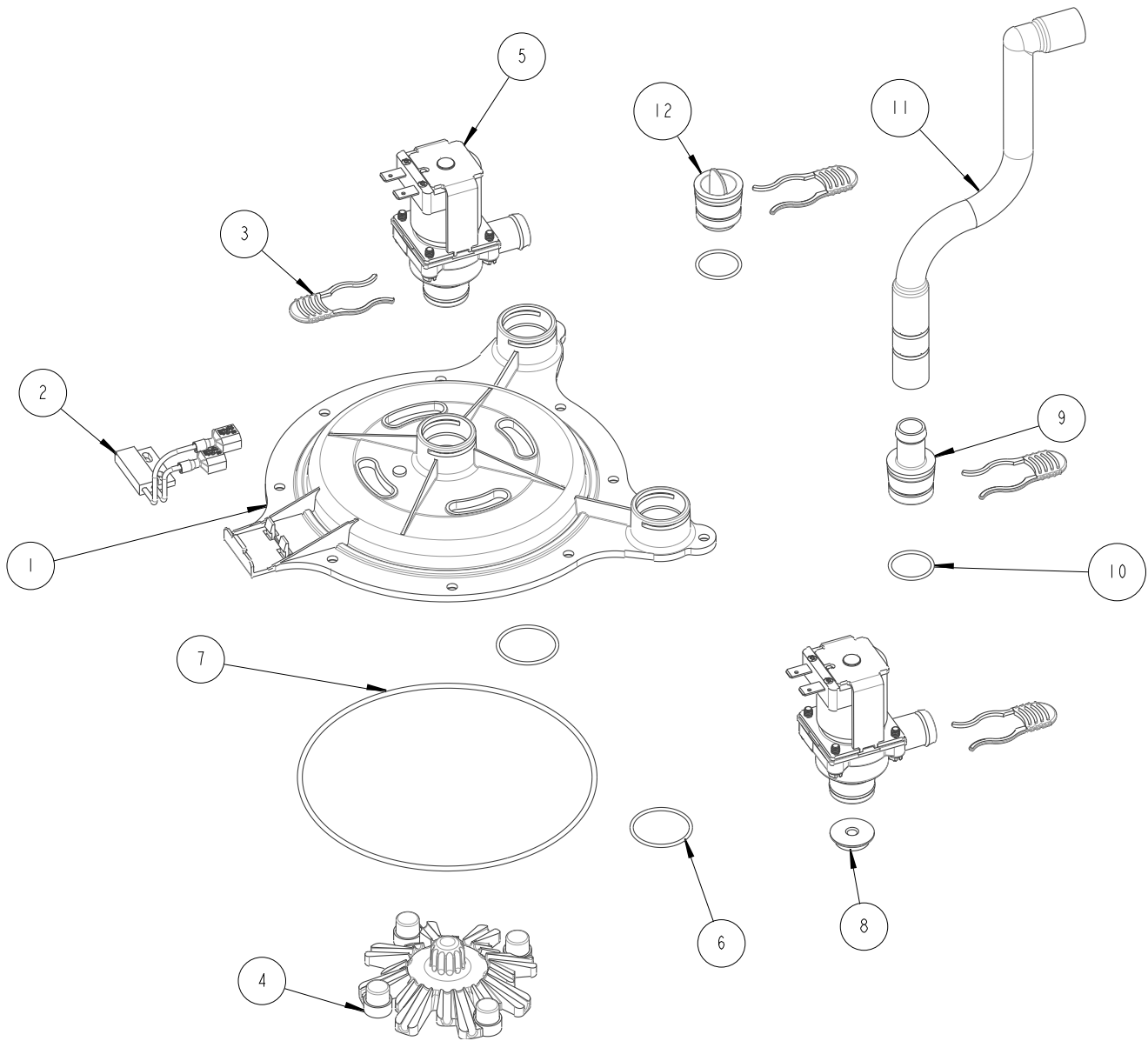

CBS-2151; CBS-1252 and CBS-1253 1102.00450.00 QUICK CONNECT SPRAY HEAD ASSEMBLY

Ref#	Qty	Part number	Description
1	1	1000.00144.00	BASE, QUICK CONNECT SPRAY HEAD
2	1	1102.00113.00	SWITCH, REED, ASSEMBLY
3	3	1023.00342.00	QUICK CONNECT CLIP
4	1	1102.00043.00	CASCADE SPRAY DOME, CBS-2050/60'S
5	2	1057.00076.00	VALVE ASSEMBLY, COMPLETE, NG, DELTROL (interchangeable with 1057.00078.00)
5	2	1057.00078.00	VALVE ASSEMBLY, COMPLETE, NG, RPE (interchangeable with 1057.00076.00)
6	2	1024.00107.00	O-RING, 1 3/16" OD X 1 1/16" ID X 1/16" TH, BYPASS SEAL
7	1	1024.00108.00	O-RING, 5 11/16"OD X 5 1/2" ID X 3/32" TH, BREW SEAL
8	1	1023.00369.00	ORIFICE INSERT, QUICK CONNECT, 3/16" HOLE (orange)
9	1	1023.00343.00	VENT INSERT, QUICK CONNECT
10	2	1024.00106.00	O-RING, 13/16"OD X 11/16"ID X 1/16" TH, FOR QUICK CONNECT
11	1	1024.00098.00	VENT TUBE, CBS- EXTRACTOR SERIES
12	1	1023.00344.00	PLUG INSERT, QUICK CONNECT



Wiring Diagrams

CBS-1251 PLUS Wiring Diagram 1401.00196.10

- E1251US-1B230-PM110 E1251KS-1B230-PM110
- E1251US-1B230-PM100 E1251IN-1B230-PM110
- E1251US-1B230-MM110 E1251IN-1B150-PM110
- E1251NM-1B230-PM110 E1251IN-1B140-PM110
- E1251BR-1B230-PM110

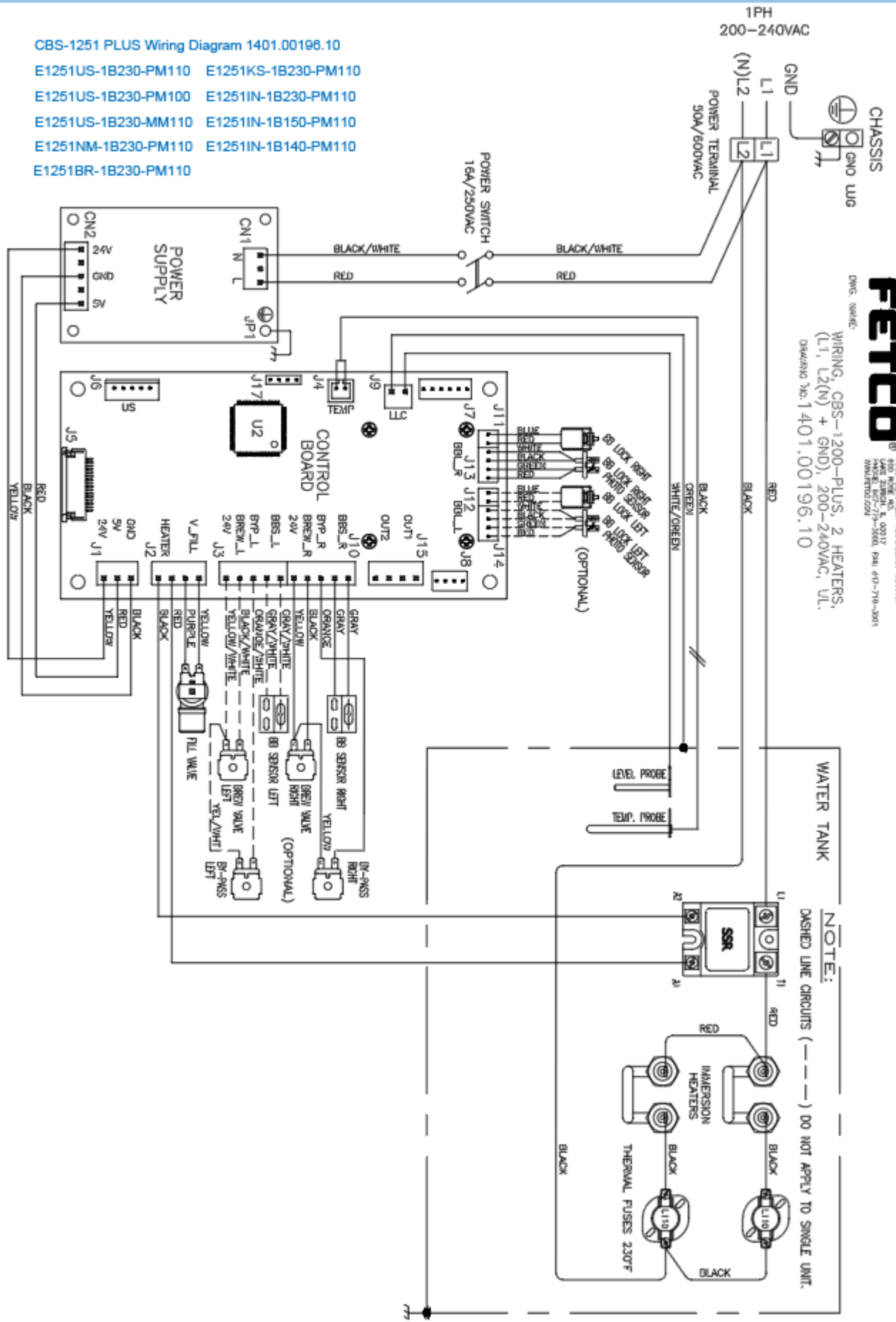

FETCO
 FOOD EQUIPMENT TECHNOLOGY COMPANY
 400 WEST 15TH ST. SUITE 200
 DENVER, CO 80202
 TEL: 303-733-7176 FAX: 303-733-7176
 WWW.FETCO.COM

WIRING: CBS-1200-PLUS, 2 HEATERS,
 (L1, L2(N) + GND), 200-240VAC, U.L.
 Drawing No. 1401.00196.10

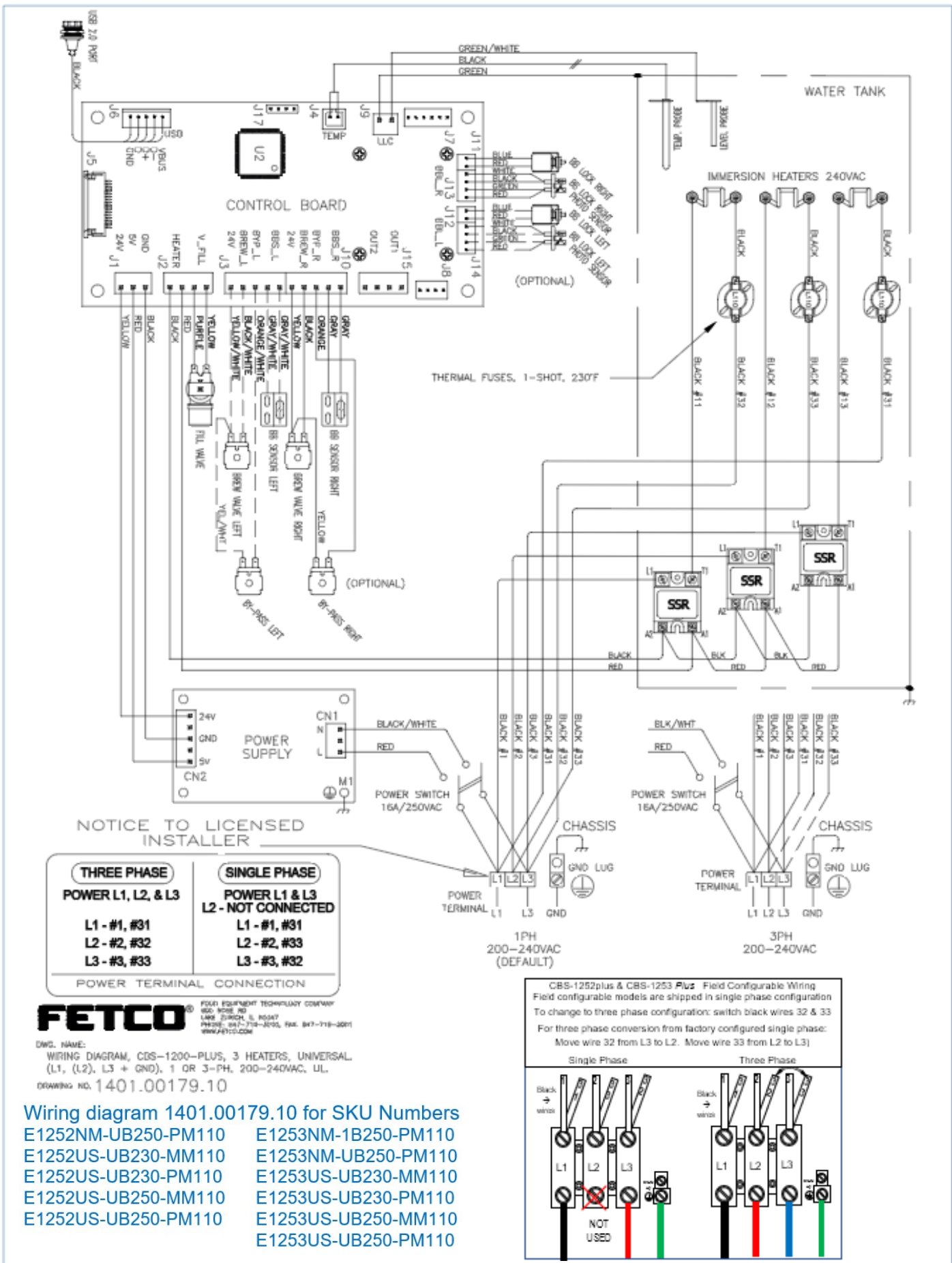

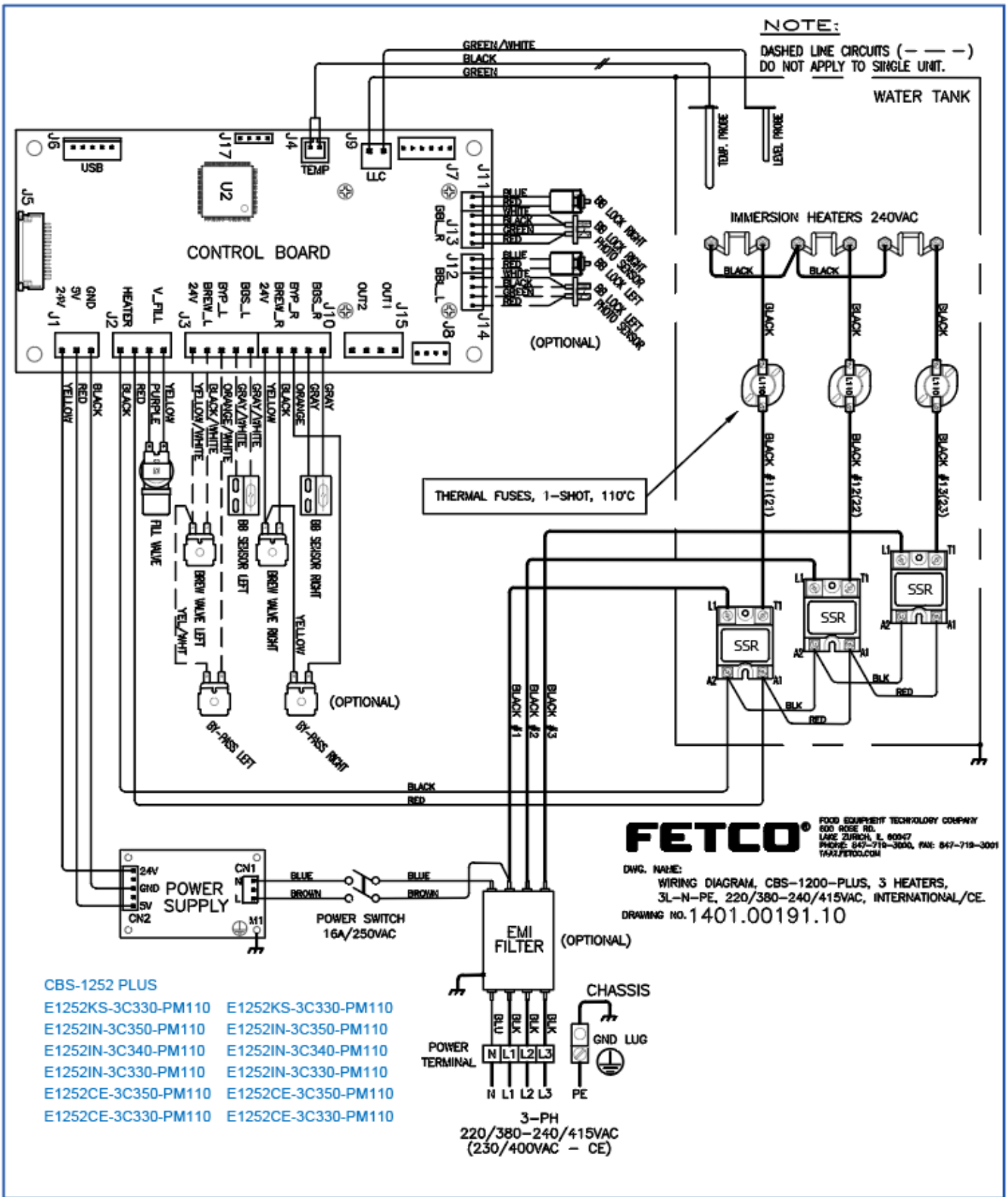

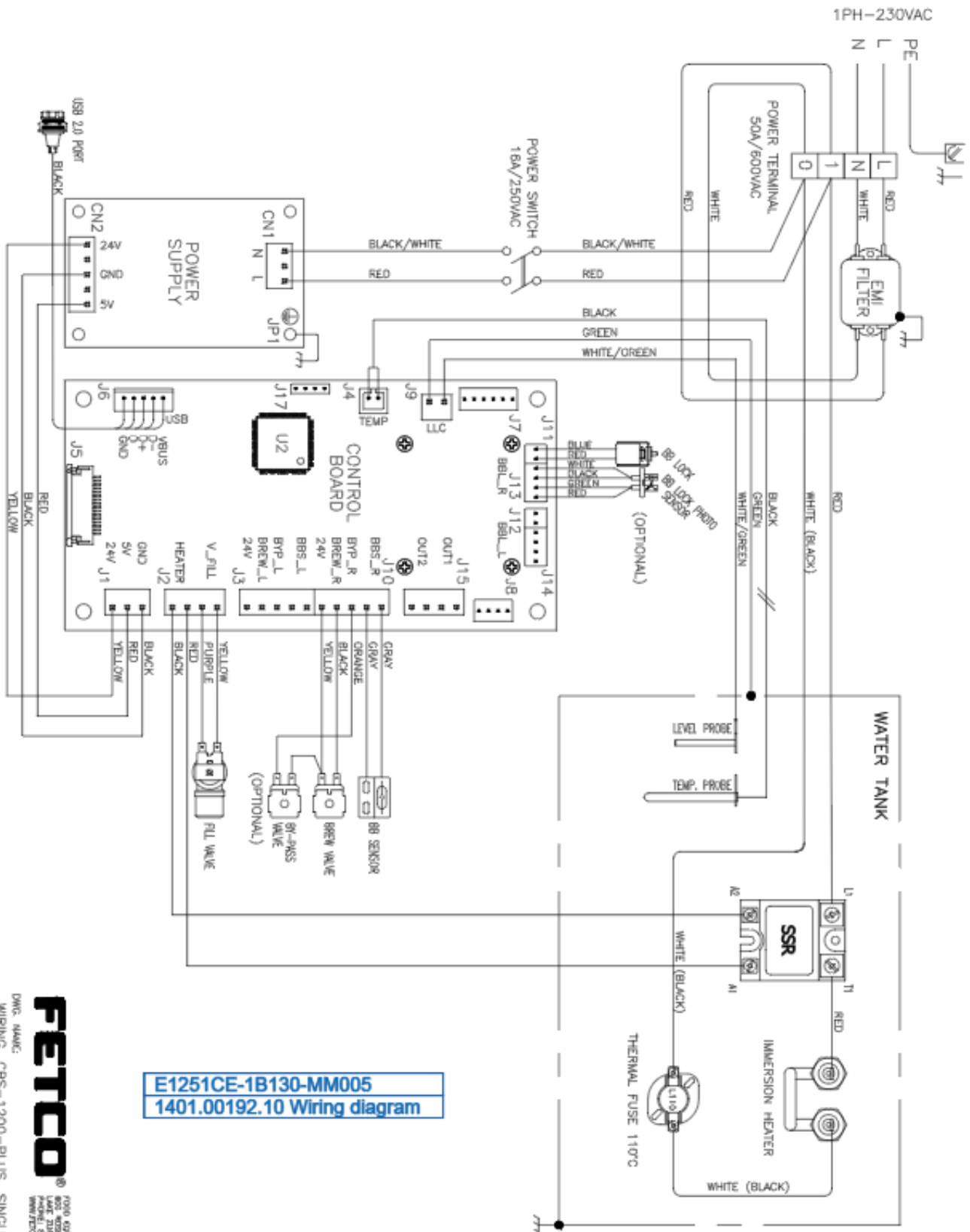

E1251CE-1B130-MM005
1401.00192.10 Wiring diagram

PETCO
 7000 GARDEN OF EDDEN COMPANY
 800 WOOD ST. SUITE 100
 FARMERSVILLE, OH 43024
 WWW.PETCO.COM

DWG. NAME:
 WIRING, CBS-1200-PLUS, SINGLE, 1 HEATER,
 L-N-PE, 1PH - 230VAC, CE.
 DRAWING NO. 1401.00192.10