



## ANGLED HOOD

Instructions booklet



**PRECAUTIONS**

INSTALLATION - 4

USE - 6

MAINTENANCE - 7

CONFIGURATION - 8

**INSTALLATION INSTRUCTIONS** - 9

AIR CONNECTION SYSTEMS - 19

FILTER VERSION - 19

EXTRACTION VERSION - 20

**INSTRUCTIONS FOR USE** - 22

CONTROL UNIT - 22

**CLEANING AND MAINTENANCE** - 32

EXTERNAL CLEANING - 32

CLEANING METAL FILTERS - 32

REPLACING ODOUR FILTERS - 33

REPLACING THE LAMPS - 36

**TREATMENT OF WEEE** - 38

## WARNING!

**Read this manual carefully before installing and/or using the hood.**

- The manufacturer will not be held liable for damage resulting from incorrect or improper installation.
- Installation and adjustments should be carried out by qualified personnel.
- Check the integrity of the hood once it has been removed from the packaging. If the product is damaged, do not use it. Contact the SMEG assistance service.
- Before connecting the appliance, make sure that the mains voltage is the same as the voltage indicated on the technical data label inside the appliance.
- For Class I appliances, make sure that the domestic power supply is suitably earthed.
- The minimum distance between the lower surface of the hood and the hob must be at least 650 mm for gas appliances and 450 mm for electric or induction appliances.
- The air that is extracted must **not** be conveyed into a duct that is used for extracting fumes from appliances powered by gas or other fuels.
- Connect the air outlet from the hood to fume extraction ducts that have an adequate internal diameter, not less than 120 mm.
- There must be adequate aeration in the room when the hood and gas appliances are operating at the same time.
- If the power cable is damaged, it should be replaced by the manufacturer or by his technical assistance service or anyway by a similarly qualified person in order to prevent possible hazards.

## WARNING!

**Read this manual carefully before installing and/or using the hood.**

- Comply with the legal requirements regarding the discharge of extracted air when the hood is in operation.
- Caution: Failure to install the screws or fixing devices in accordance with these instructions may result in electrical hazards
- **For Australia and New Zealand:** Range hoods and other cooking fume extractors may adversely affect the safe operation of appliances burning gas or other fuels (including those in other rooms) due to the back flow of combustion gases. These gases can potentially result in carbon monoxide poisoning. After installation of a range hood or other cooking fume extractor, the operation of flued gas appliances should be tested by a competent person to ensure that back flow of combustion gases does not occur.  
(AS/NZS 60335.2.31:2020)

- Do not cook or fry in a way that creates strong flames that may be drawn by the hood while it is in operation and cause a fire.
- Do not flambé foods under the hood: Risk of fire.
- This appliance may be used by children under 8 years of age and by persons with reduced physical, sensory or mental abilities or who lack experience or the necessary knowledge if they are supervised or after they have been given instructions on the safe use of the appliance and understand the hazards involved.
- Children should be supervised to make sure they do not play with the appliance.
- The front panel should only be opened for carrying out maintenance; it must remain closed during use.

**CAUTION:** accessible parts may become very hot when used with cooking appliances.

- Disconnect the appliance from the power supply before carrying out cleaning or maintenance.
- Maintain the filters carefully and regularly according to the schedule recommended by the manufacturer.
- Clean the surfaces of the hood using a damp cloth and a neutral liquid detergent.
- There is a risk of fire if cleaning is not carried out according to the instructions
- Cleaning and maintenance intended to be carried out by the user must **not** be performed by children unless they are supervised.
- Always wear work gloves when carrying out installation and maintenance.
- The hood must NEVER be used as a support surface unless specifically indicated.
- Do not use or leave the hood without the lamps correctly installed due to the possible risk of electric shock.

**THE MANUFACTURER DECLINES ANY LIABILITY IF THE ABOVE INSTRUCTIONS ARE NOT FOLLOWED.**

This appliance has been designed to be used as an **EXTRACTOR** hood (extraction of air to the outside) or as a **FILTER** hood (air is recirculated indoors).



### **EXTRACTION VERSION**

To configure the hood as the extraction version, connect the motor outlet using a rigid or flexible pipe having an internal diameter of not less than 120 mm, directly to the external steam and odour extraction system.

Note Remove any activated carbon filters.



### **FILTER VERSION**

If it is not possible to discharge the steam and odours to the outside, the hood can be used as a filter. In this configuration, the air and vapours are cleaned by the odour filters and recirculated into the room via the ventilation grids on the side of the duct cover.

Note: using the hood in the filter version may increase the perceived noise level.

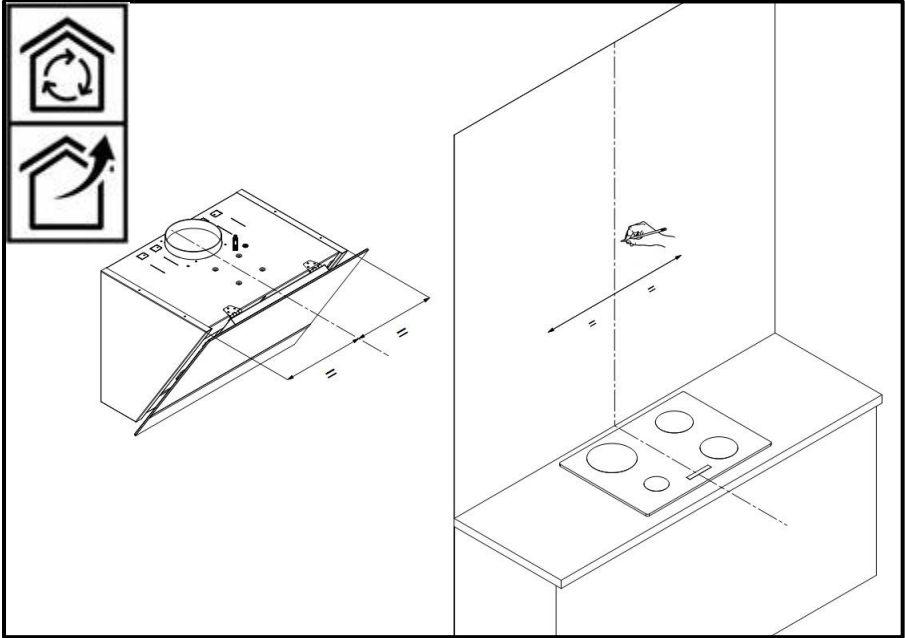

	L1	L2	L3	L4
<b>KV26</b>	372	200	254	133
<b>KV28</b>	372	200	254	133
<b>KV394</b>	372	200	254	133
<b>KVFAB</b>	372	200	254	133
<b>KV194</b>	440	172	147	239
<b>KV694</b>	440	172	147	239

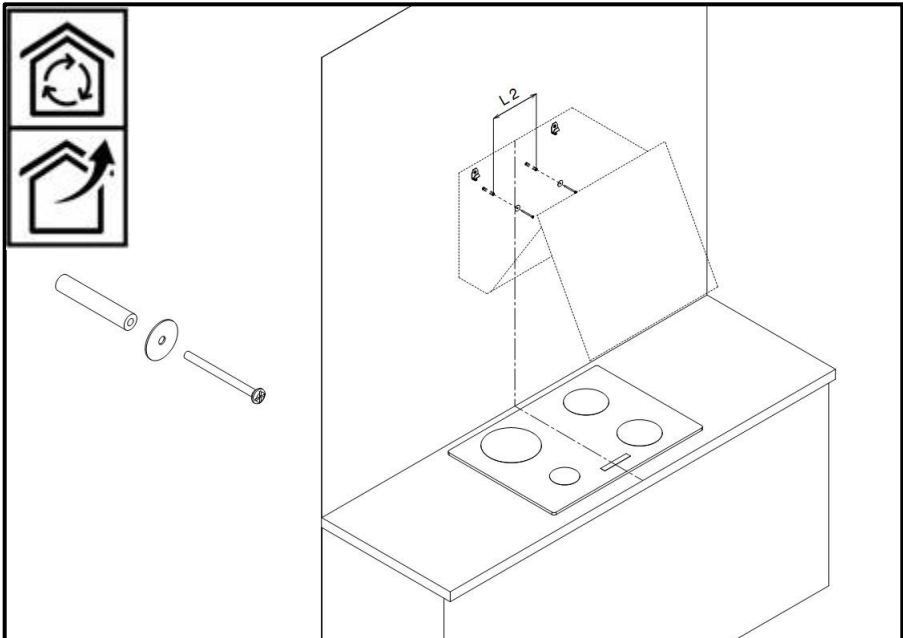
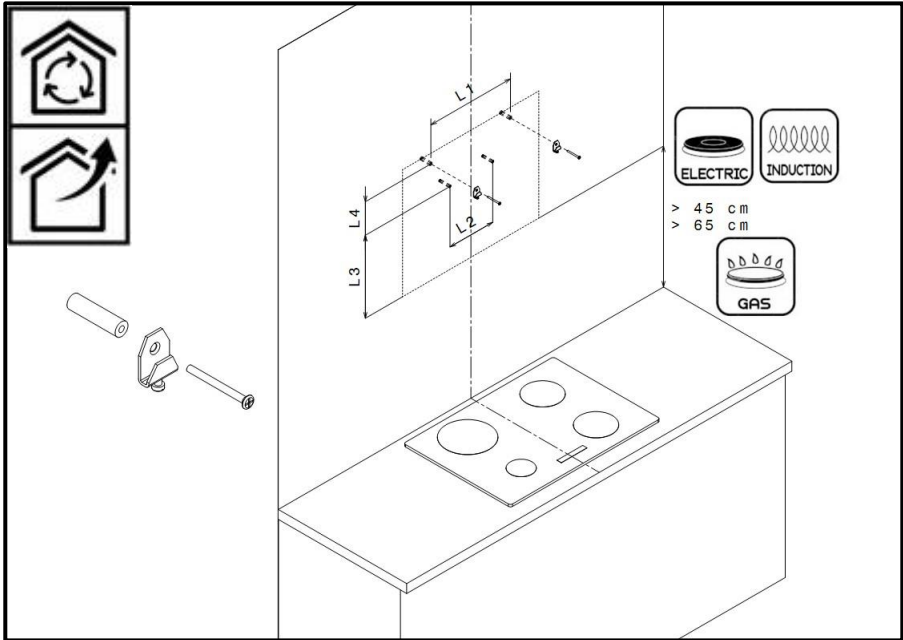

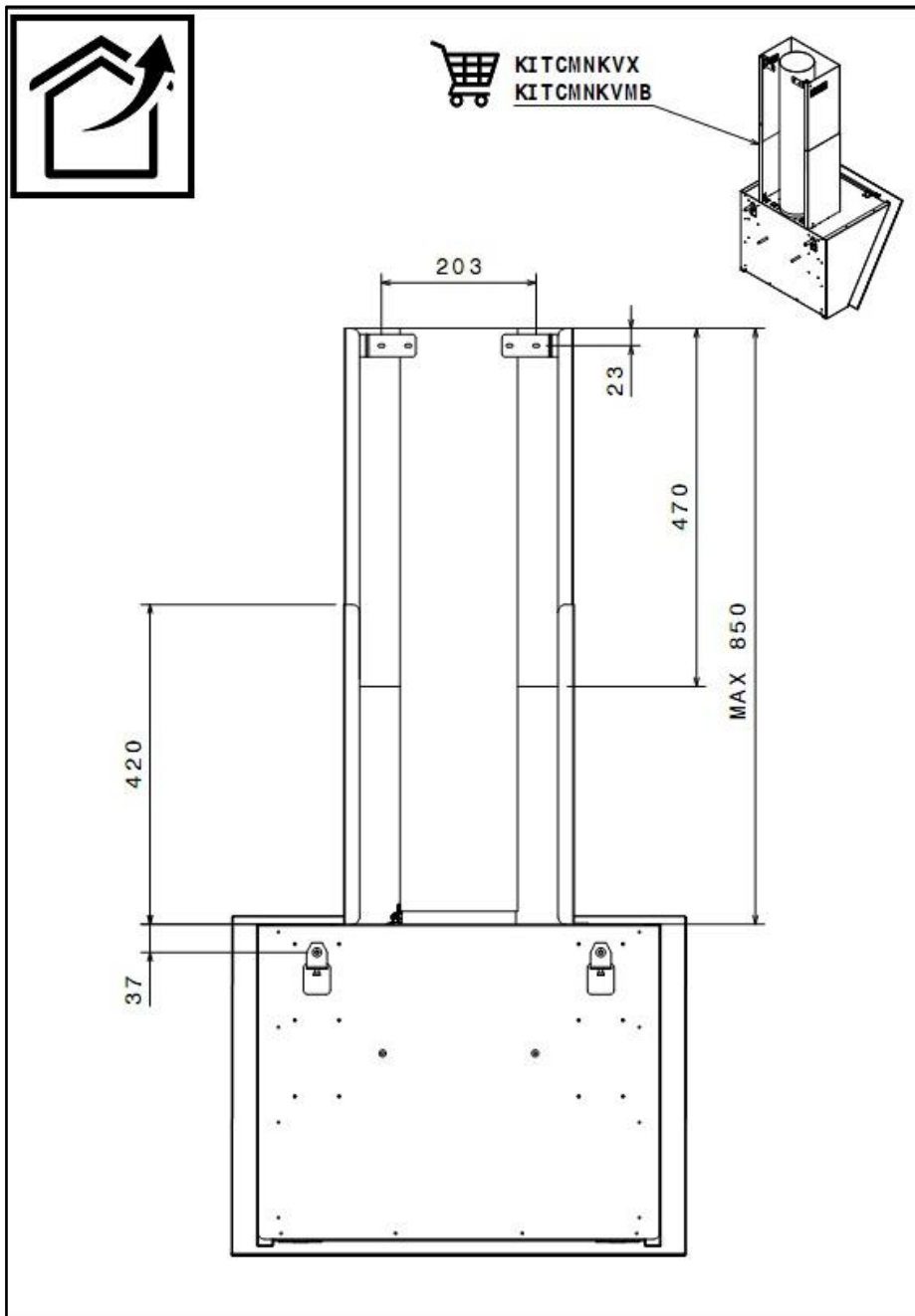

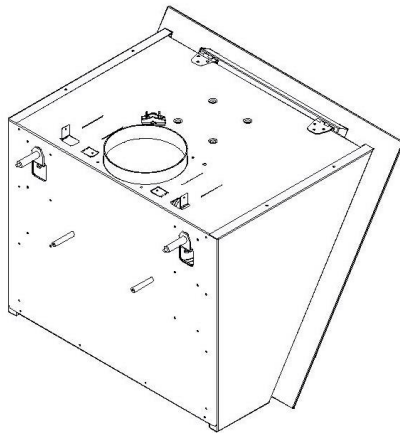
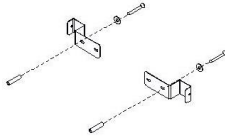
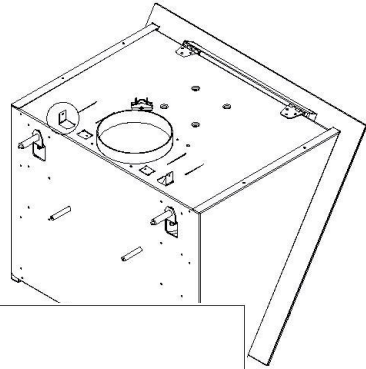
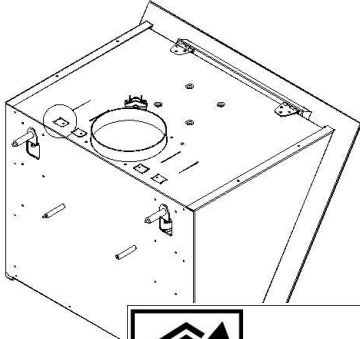
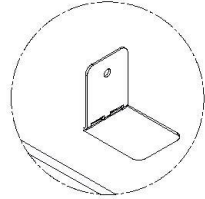
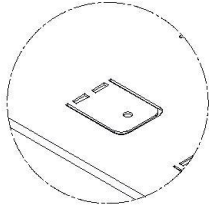

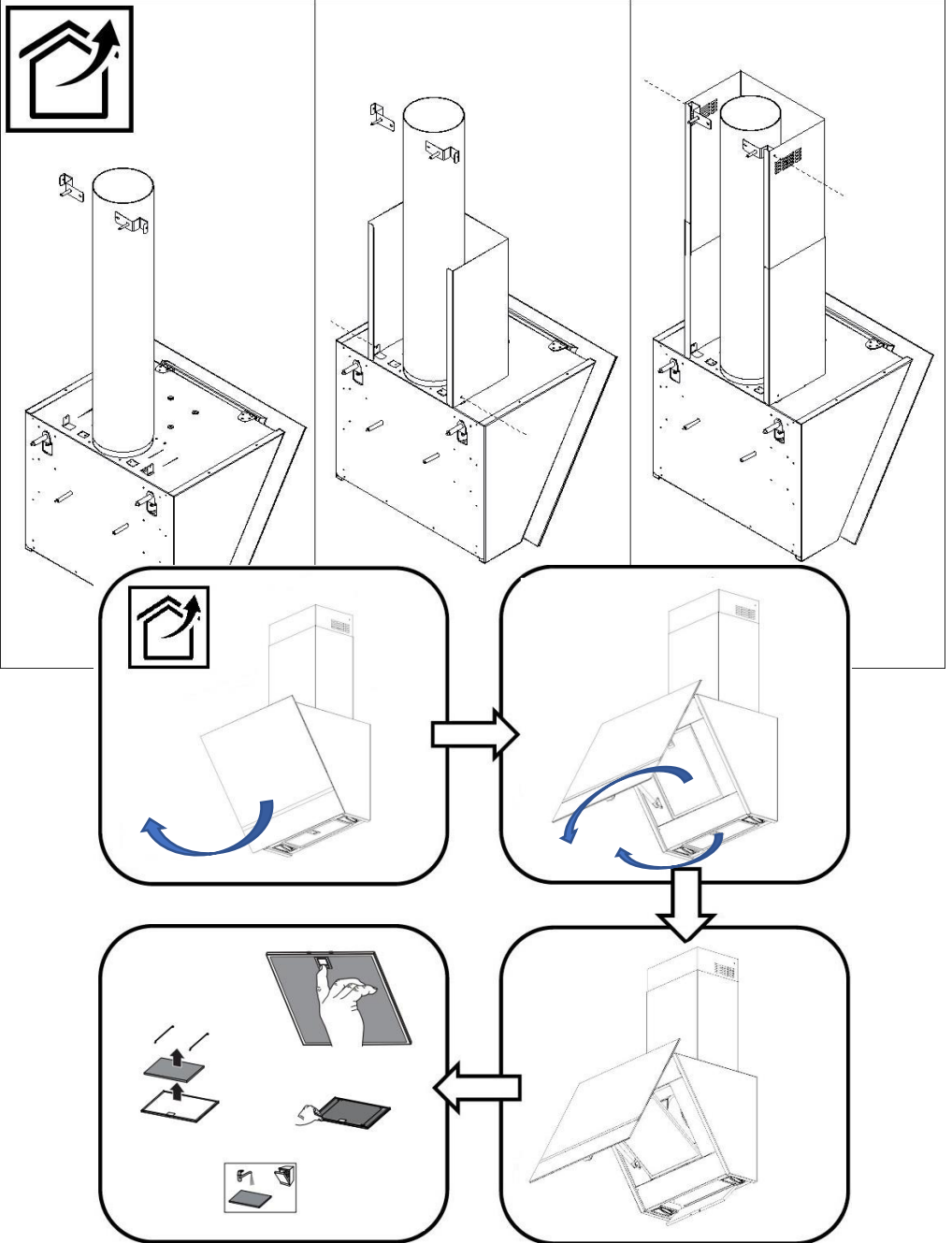

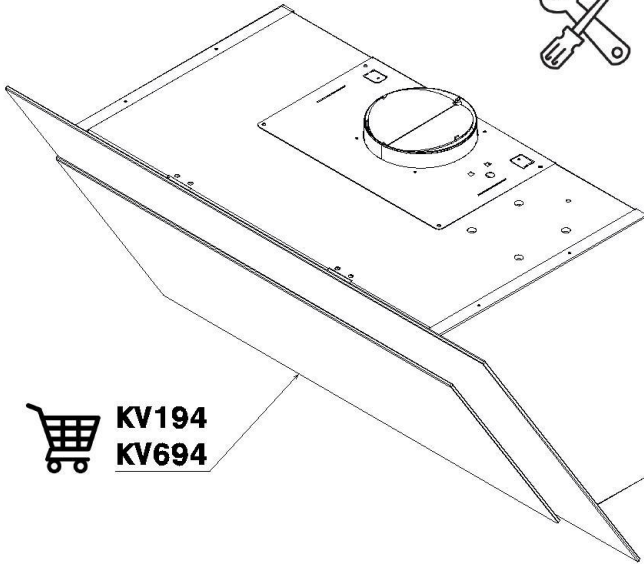

 **KV194**  
**KV694**

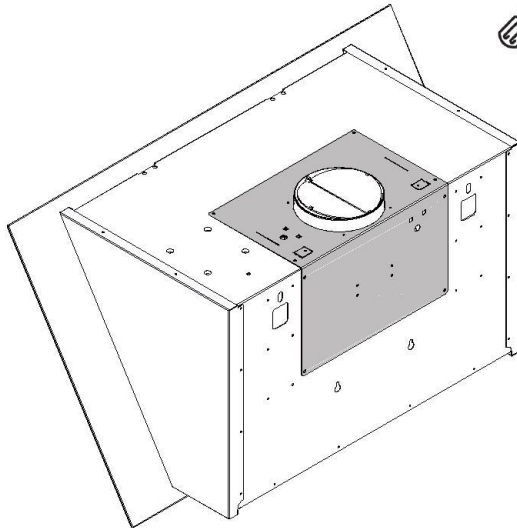
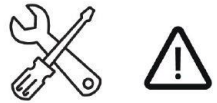

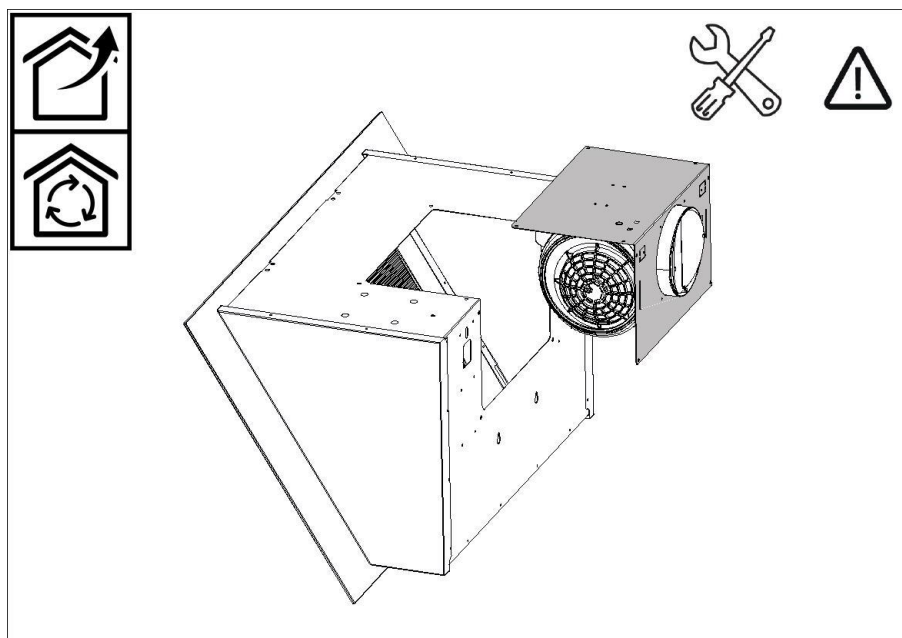
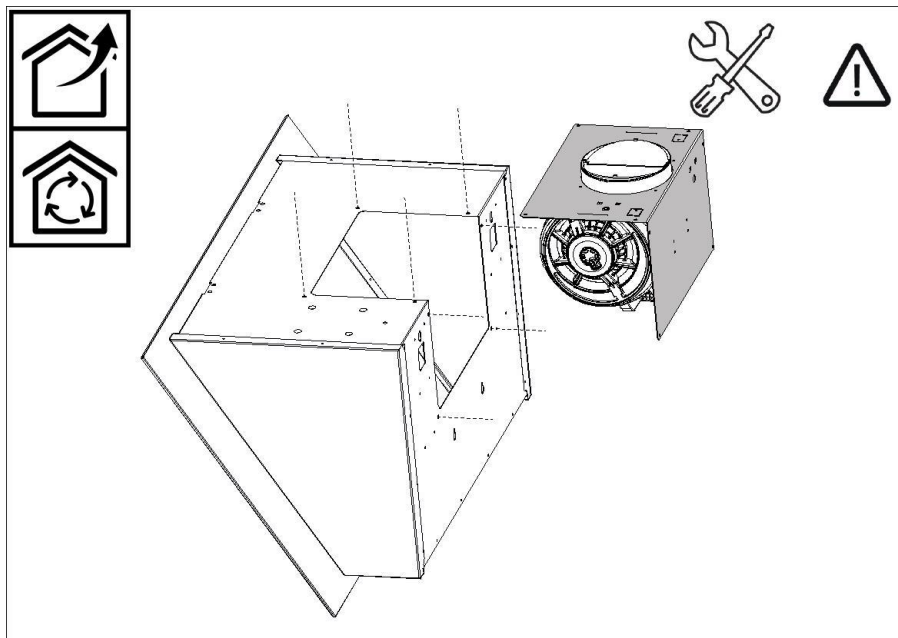

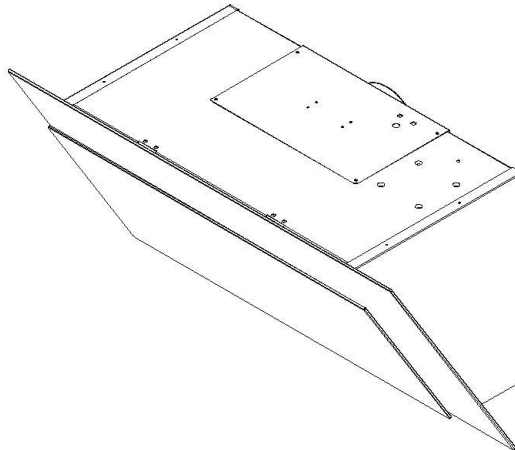
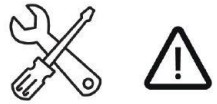
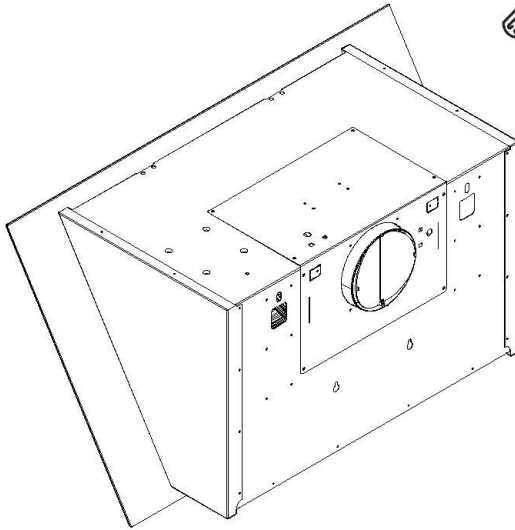

The hood is supplied with all the accessories required for installation. For the minimum distance between the lower surface of the hood and the type of hob, please refer to the image on page 9. The hood is fitted with a fume non-return valve, make sure that it is free to open and close.

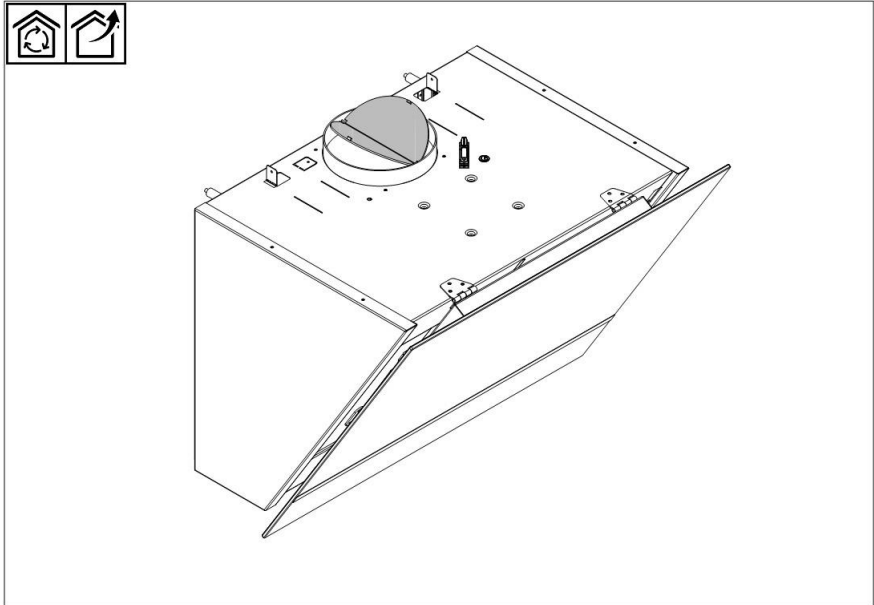

For easy installation, we recommended that you follow the procedure below:

- 1) The hood should be centred with respect to the hob; see the figure on page 9.
- 2) Take 2 levelling hooks with expansion plugs, supplied. This mounting system has to be used in the holes **L1** on the back of the hood; see the figure on page 9.
- 3) Remove the grease filters, position the hood on the wall and mark the position of the holes **L1**.

4) Remove the hood from the wall and drill the 2 holes.

5) Secure the mounting systems to the wall by tightening the expansion plugs.

6) Hang the hood from the holes **L1** and level it using the adjustment screws.

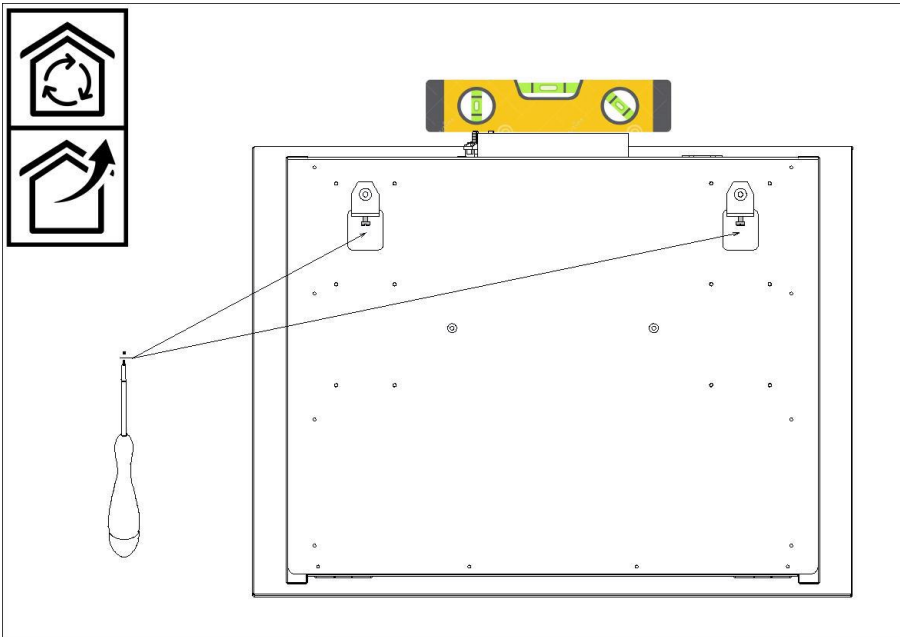

7) Mark the position of the holes **L2** on the wall for fastening the hood.

8) Remove the hood from the wall and drill the 2 holes **L2**.

9) Secure the mounting systems to the wall by tightening the expansion plugs.

10) Hang the hood from holes **L1**, secure the hood by tightening the 2 expansion screws in the holes **L2**.

## FILTER VERSION

Leave the motor inlet unobstructed.

Odour filters are already fitted to some hoods by the manufacturer.

Refer to the following pages to find out which models are fitted with odour filters.

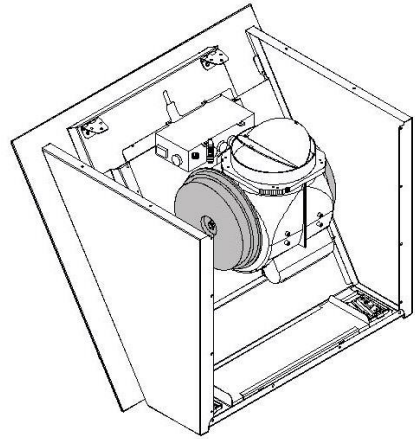
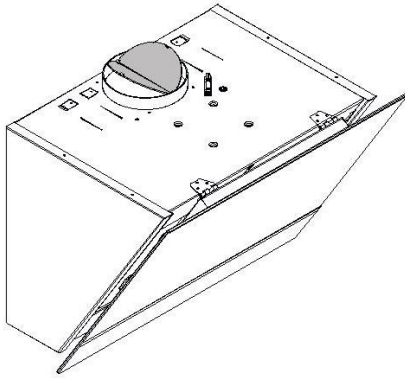

### EXTRACTION VERSION

The maximum length of the duct covers is 850 mm. Bend the two appendages for fastening the lower duct cover by 90°; see the figure on page 12. Position the 2 brackets for the upper duct cover at the upper limit indicated; see figures on pages 11 and 12. Mark the two holes on the wall for fastening the brackets. Drill the holes and fasten the brackets using the expansion plugs provided. Connect the fume extraction duct (inside diameter  $\varnothing$  150 mm) to the motor outlet. The duct is **not** supplied. The diameter of the extraction duct must not be less than  $\varnothing$  120 mm. Carefully place the two duct covers on the hood. Move the upper duct cover slightly to allow the lower duct cover to be fastened to the hood using the 2 screws. Lift the upper duct cover to the specified upper limit. Secure the upper duct cover to the brackets using 2 screws, see figure on page 13.

**CAUTION:** remove the two odour filters from the hood.

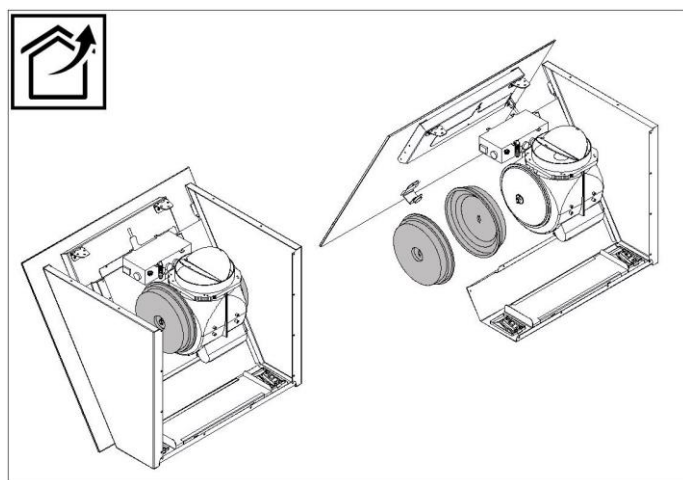

Electrical connections should be carried out by a qualified installer.

In the case of direct electrical connection to the mains, a suitable bipolar switch with a minimum contact separation of 3 mm and that complies with current standards should be installed between the appliance and the power supply.

## CONTROL UNIT

For an optimal and efficient use of the product, it is recommended that you switch on the hood a few minutes before you start cooking and keep it on for at least 15 minutes after you have finished or until the steam and odours have been completely eliminated. The following types of controls can be found on the front of the hood:

### 6-button control panel

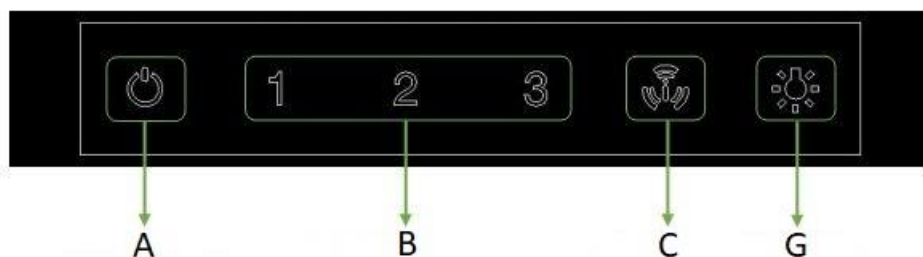

### 9-button control panel

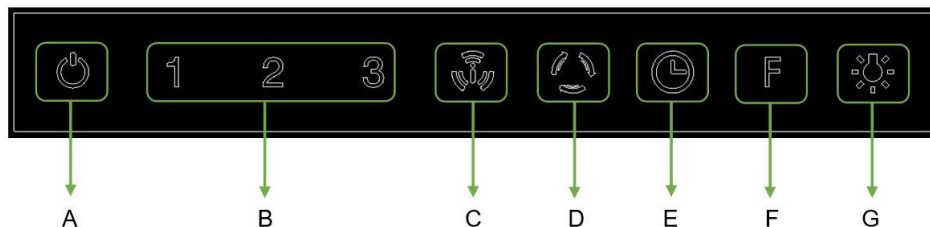

## 6-button control panel

---

- A) Shutdown timer
  - B) Speed selection
  - C) Turbo function
  - G) Light brightness adjustment
- Light colour temperature adjustment





### Touch Technology

---

The unit uses capacitive sensors to detect the touch of the button on the front glass panel.



### Lighting

---

When power is turned on, the unit will be in the off mode. Only the  button is illuminated (low brightness). After touching the  button, the unit will go into Stand-By mode and all buttons will be dimly lit. In Stand-by mode, the user can activate any function that is allowed by the operating logic. The button of the active function will be brightly lit.

## Button functions

---

-  Hood OFF button. (If the fan and the lights are on).
- 1** Speed 1 button. Lights up when the motor is running at speed 1.
- 2** Speed 2 button. Lights up when the motor is running at speed 2.
- 3** Speed 3 button. Lights up when the motor is running at speed 3.
-  Turbo speed button. Lights up when the motor is running at speed 4. The motor switches from speed 4 to speed 3 after about 7 minutes. When the Turbo function is active, the button flashes and the timer function is not active.
-  Lights On/Off button. Illuminated when the light is on.
- 1** - **2** - **3** Pressing these buttons twice activates the timer. The timer function can only be activated when the fan motor is on. Once activated, a 10-minute timer starts, when the time elapses, the motor stops and the light switches off. The button flashes during this time. The timer can be cancelled by touching the same button.



## Light brightness adjustment

Briefly touching the  button immediately switches the lights on or off. Touching and holding this button for more than 1 second gradually increases the brightness to the maximum level and then decreases it to the minimum level as long as the button is pressed. Release the button once you have obtained the required brightness. This level of brightness will be saved in the non-volatile memory so that it will be set each time the light is switched on by tapping the button once. Tapping the light button twice when the light is off will set it to maximum brightness. It is factory set to maximum brightness.





## Filter alarm reset

After 100 hours of hood operation, buttons **1**, **2**, **3**, will start to flash to remind you to clean the filters. To reset this warning, press the On/Off button for 5 seconds, the light of the On/Off button will flash once to indicate that the filter time has been reset.



## 24h air exchange function

The 24h air exchange function allows you to clean the air in the room. To start the 24 hour function, press and hold the  button for 3 seconds. The extraction hood will run at minimum speed for 10 minutes every hour (up to a maximum of 24 hours). The **1** and  buttons will flash as long as the function is active. Briefly touching any button (apart from the  button) will disable the function.

## 9-button control panel

---

- A) Shutdown timer
  - B) Speed selection
  - C) Turbo function
  - D) 24h air exchange function
  - E) Automatic switch-off
  - F) Filter alarm reset
  - G) Light brightness adjustment
- Light colour temperature adjustment
- Hob and hood connection





### Touch Technology

---







The unit uses capacitive sensors to detect the touch of the button on the front glass panel.

### Lighting

---

When power is turned on, the unit will be in the off mode. Only the  button is illuminated (low brightness). After touching the  button, the unit will go into Stand-By mode and all buttons will be dimly lit. In Stand-by mode, the user can activate any function that is allowed by the operating logic. The button of the active function will be brightly lit.

## Button functions

- 
-  Hood OFF button. (If the fan and the lights are on).
- 1** Speed 1 button. Lights up when the motor is running at speed 1.
- 2** Speed 2 button. Lights up when the motor is running at speed 2.
- 3** Speed 3 button. Lights up when the motor is running at speed 3.
-  Turbo speed button. Lights up when the motor is running at speed 4. The motor switches from speed 4 to speed 3 after about 7 minutes. When the Turbo function is active, the button flashes and the timer function is not active.
-  24h air exchange function button. Lights up when the motor is running at speed 1. Briefly touching  activates motor speed one and extracts air for 10 minutes every hour for 24 hours. Press the button again to disable it.
-  Automatic switch-off button. The button is illuminated while the fan is in operation at the selected speed (1-2-3). Briefly touching  activates the automatic switch-off delay of 15 minutes. Suitable for eliminating residual odours. It can be activated at fan speeds 1, 2 or 3. It is disabled by pressing the button or by switching off the fan.
- F** Filter alarm reset button. The alarm is activated after 100 hours of actual hood operation. When the filter alarm is on, pressing the **F** button for about 3 seconds resets the alarm. If there is no filter alarm, pressing the **F** button has no effect (apart from the light colour temperature adjustment function below). Before resetting the alarm signal, the activated charcoal filters have to be replaced and the metal grease filters should be cleaned.
-  Lights On/Off button. Illuminated when the light is on.
- 1** - **2** - **3** Pressing these buttons twice activates the timer. The timer function can only be activated when the fan motor is on. Once activated, a 10-minute timer starts, when the time elapses, the motor stops and the light switches off. The button flashes during this time. The timer can be cancelled by touching the same button.



## Light brightness adjustment

---

Briefly touching the  button immediately switches the lights on or off. Touching and holding this button for more than 1 second gradually increases the brightness to the maximum level and then decreases it to the minimum level as long as the button is pressed. Release the button once you have obtained the required brightness. This level of brightness will be saved in the non-volatile memory so that it will be set each time the light is switched on by tapping the button once. Tapping the light button twice when the light is off will set it to maximum brightness. It is factory set to maximum brightness.





## Light colour temperature adjustment

---

Touch **F** again, touch and hold the  button for at least 1 second to activate the light colour temperature adjustment function. The temperature of the light changes gradually and circularly from cold to warm. Release the button once the required colour temperature has been obtained. This colour temperature will be saved in the non-volatile memory so that it will be used each time the light is switched on by tapping the button once.

## GHOST function

---

When this product is turned off, only the  button remains illuminated (at low brightness). If the  button is pressed, the hood will be set to standby and all buttons will light up with a brightness of 5%. When in standby, if a function is activated, the relative button will light up with 100% brightness. If you press the  button, the hood returns to standby mode and all buttons will light up with a brightness of 5%.



## Filter alarm reset



---

After 100 hours of hood operation, buttons **1** , **2** , **3** , will start to flash to remind you to clean the filters. To reset this warning, press the On/Off button for 5 seconds, the light of the On/Off button will flash once to indicate that the filter time has been reset.



## 24h air exchange function

---

The 24h air exchange function allows you to clean the air in the room. To start the 24 hour function, press and hold the  button for 3 seconds. The extraction hood will run at minimum speed for 10 minutes every hour (up to a maximum of 24 hours). The **1** and  buttons will flash as long as the function is active. Briefly touching any button (apart from the  button) will disable the function.



## Hob and hood connection

### Automatic operation specifications – Auto-Vent 2.0

Some models are provided with a wireless communication system to allow them to be controlled automatically via an induction hob.

#### Automatic switch-on

When the hob is switched on, the hood switches on if it is in STANDBY mode (all buttons illuminated at low brightness).

#### Operation in automatic mode

Automatic mode of operation is shown on the hood user interface as follows.

For example, if the fan motor is operating at speed 2 and the appliance is in automatic mode:

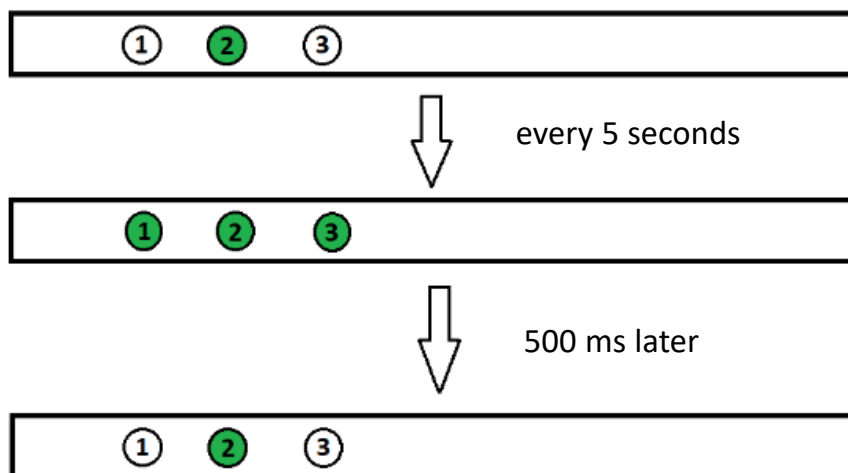

#### Automatic switch-off

When the hob is switched off, the hood switches to STANDBY mode (all buttons illuminated at low brightness).



## Hob and hood connection

---

### Automatic / manual operation

If the hood is operating in automatic mode and the customer changes some hood parameters via the user interface, automatic mode will be disabled and the hood will no longer respond to the Auto-Vent 2.0 command from the hob.

To re-enable automatic mode, the hood first has to be set to OFF and then to STANDBY mode.

**Always disconnect the hood from the power supply before carrying out cleaning and/or maintenance.**

Regular cleaning ensures that the appliance provides good performance and a long service life. Special attention should be paid to the grease filters and carbon filters.

**Note: The accumulation of grease inside the filter panels as well as affecting the performance of the extractor hood can also be a fire hazard.**

### EXTERNAL CLEANING

The hood should be cleaned externally and internally using a damp cloth and a neutral liquid detergent. Solvents or abrasive substances should not be used under any circumstances. We recommend using specific products, following the instructions on the pack. We recommended that you always clean the steel parts of the hood in the direction of the surface finish.

### CLEANING METAL FILTERS

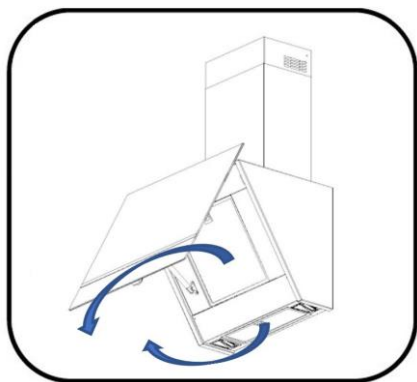

Particular attention should be paid to the metal grease filter panels. The accumulation of grease inside the filter panels as well as affecting the performance of the extractor hood can also be a fire hazard. In order to minimise the risk of fire, the filters should be cleaned regularly, at least once a month or more often in the case of intensive use of the appliance.

Remove one filter at a time as shown in the figure. Wash the filters thoroughly by hand using a neutral detergent or in a dishwasher. Reinstall the filters, making sure that the handle is facing towards the outside of the hood.



## REPLACING ODOUR FILTERS

(filter version only)

This type of filter retains odours until the material becomes saturated. They cannot be washed and cannot be regenerated. It is therefore recommended to replace them at least every six months or more frequently if the hood is used intensively.

Before starting, make sure you have disconnected the hood from the power supply. There are two types of filters according to the model of the hood: on the motor and on the grease filters.

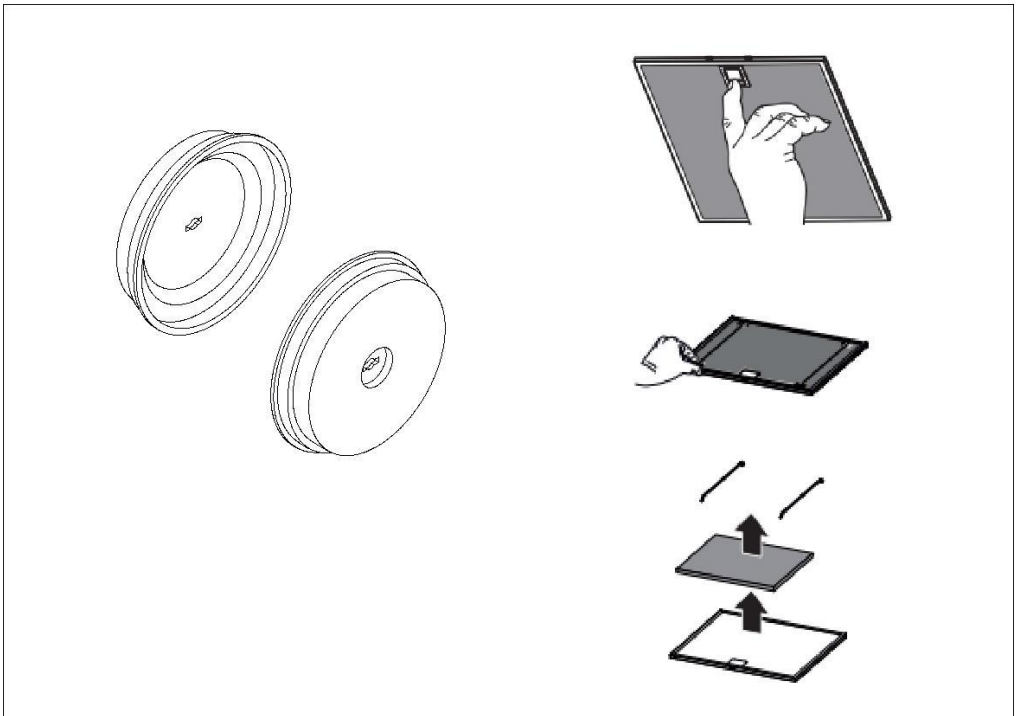



## ODOUR FILTERS ON MOTOR

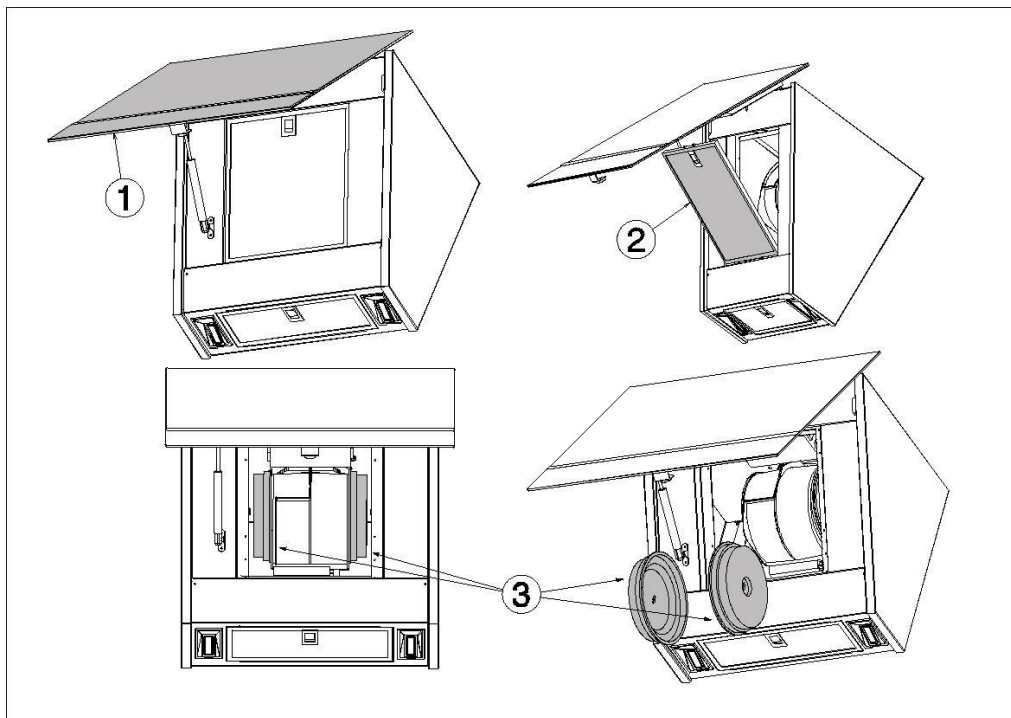

- 1) Open the panel
- 2) Remove the grease filter
- 3) Rotate the used odour filters by 90° and remove them from their seat
- 4) Take 2 new filters, insert them on the motor and rotate them by 90°
- 5) Reinstall the grease filter
- 6) Close the panel

### Models

KV26 – KV28 – KV394 - KVFAB



## ODOUR FILTERS ON GREASE FILTERS

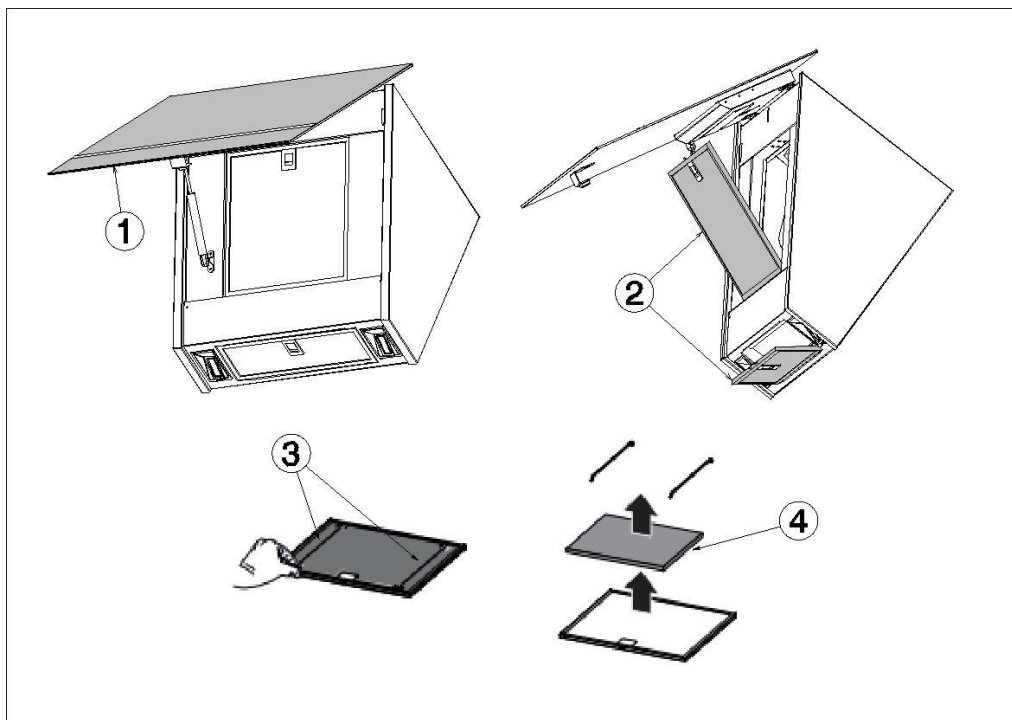

- 1) Open the panel
- 2) Remove the grease filters
- 3) Remove the retaining springs
- 4) Replace the odour filter
- 5) Reinsert the retaining springs
- 6) Reinstall the grease filters
- 7) Close the panel

**Models**

KV194 – KV694

**Always disconnect the hood from the power supply before carrying out cleaning and/or maintenance.**

The hood is fitted with a LED lighting system.

The LED lights guarantee optimal lighting, last up to 10 times longer than traditional lamps and use 90% less power.

This appliance is fitted with a Class 1M white LED light according to standard EN 60825-1:1994 + A1:2002 + A2:2001; maximum optical power emitted@439nm:  $7\mu\text{W}$ .

Do not look at the light directly using optical instruments (binoculars, magnifying glass etc.).

If it needs to be replaced, contact the Technical Assistance Centre.

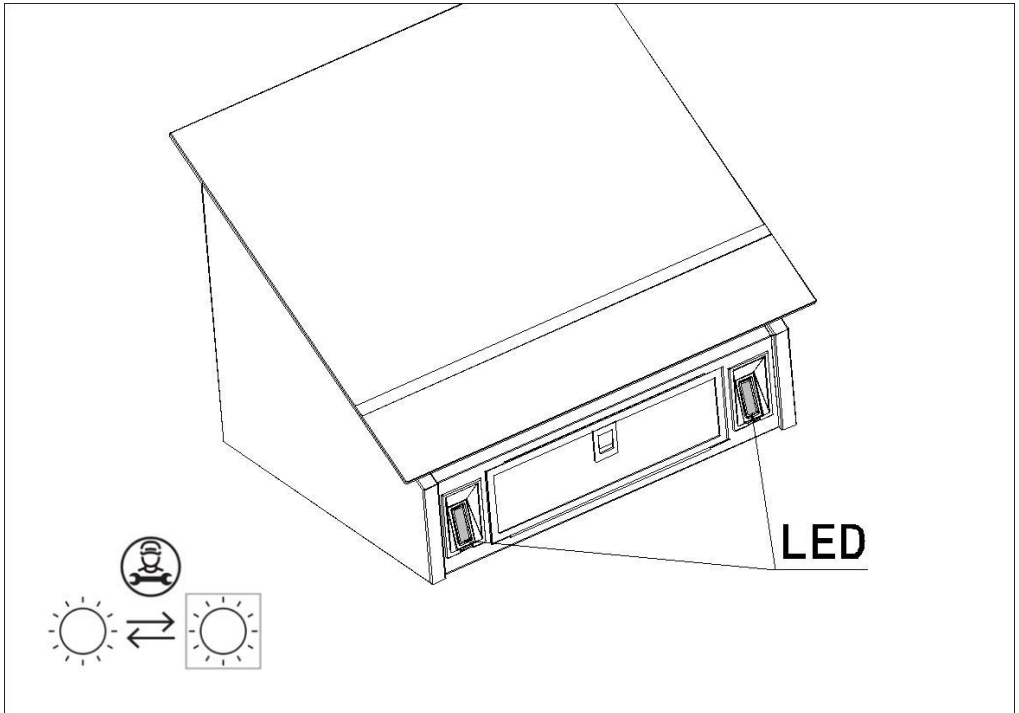

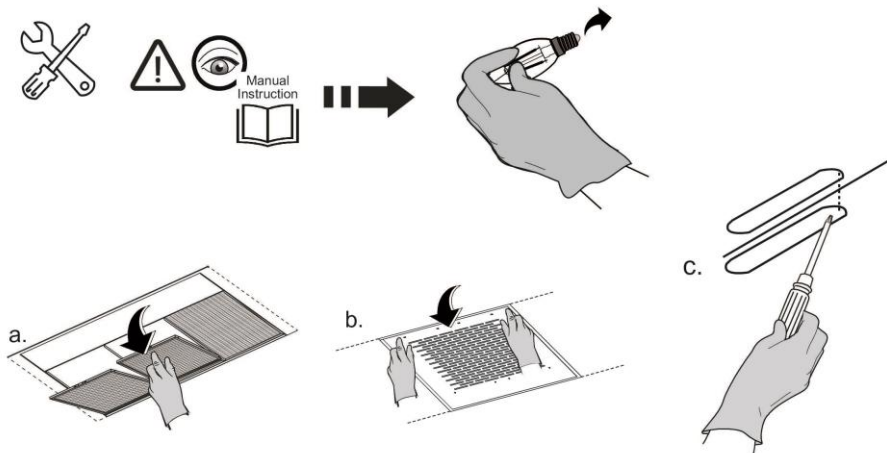

IT - Il sistema di illuminazione non è sostituibile dall'utente, in caso di malfunzionamenti contattare il servizio assistenza.

EN - The lighting system cannot be replaced by the user, contact Customer Service in case of malfunction.

DE - Das Beleuchtungssystem kann nicht vom Anwender ausgetauscht werden, wenden Sie sich bitte bei Betriebsstörungen an den Kundendienst.

FR - Le système d'éclairage ne peut pas être remplacé par l'utilisateur ; en cas de dysfonctionnement, contacter le service d'assistance.

NL - Het verlichtingssysteem kan niet door de gebruiker vervangen worden: neem in geval van storingen contact op met de servicedienst.

ES - El sistema de iluminación no es sustituible por el usuario, en caso de mal funcionamiento póngase en contacto con el servicio de asistencia técnica.

PT - O sistema de iluminação não pode ser substituído pelo utilizador, em caso de mau funcionamento, entre em contacto com o serviço de assistência.

EL - Το σύστημα φωτισμού δεν μπορεί να αντικατασταθεί από τον χρήστη, σε περίπτωση δυσλειτουργίας επικοινωνήστε με την υπηρεσία υποστήριξης.

SV - Belysningsystemet kan inte bytas ut av användaren, kontakta kundtjänst vid felfunktion.

FI - Käyttäjä ei voi vaihtaa valaistusjärjestelmää. Jos siihen tulee toimintahäiriötä, ota yhteyttä valtuutettuun huoltoon.

NO - Lysanlegget kan ikke skiftes ut av brukeren. Hvis det oppstår feilfunksjoner bes man kontakte kundeservice.

DA - Belysningsystemet kan ikke udskiftes af brugeren, kontakt servicecenteret i tilfælde af funktionfejlf.

PL - Użytkownik nie może wymieniać systemu oświetlenia, w razie nieprawidłowości należy skontaktować się z serwisem obsługi.

CS - Systém osvětlení nemůže být vyměňován uživatelem, v případě poruchy kontaktujte servisní službu.

SK - Systém osvetlenia nemôže vymeniť používateľ, v prípade funkčných porúch sa skontaktujte s asistenčnou službou.

HU - A világítási rendszer cseréjét nem végezheti a felhasználó, működési rendellenesség esetén lépjen kapcsolatba a műszaki szervizszolgálattal.

BG - Системата за осветление не може да бъде заменена от потребителя, в случай на неизправности, свържете се с отдел техническо обслужване.

RO - Sistemul de iluminat nu poate fi schimbat de către utilizator. În caz de probleme de funcționare, adresați-vă departamentului de asistență.

RU - Пользователь не может производить замену системы подсветки. В случае неполадок связывайтесь со службой технической поддержки.

UK - Користувач не може робити заміну системи підсвічування. У разі неполадок зв'яжіться зі службою технічної підтримки.

KK - Жарыктандыру жүргезиң пайдаланушы аүйсызга алмайды, егер ол жұмыс істемесе, тұтынушыларға қызмет көрсету орталығына хабарласыңыз.

ET - Kasutaja ei saa valgustusüsteemi ise välja vahetada, rikekorral pöörduge müügiärgase teeninduse poole.

LT - Apšvietimo sistemos naudotojas negali pakeisti. Jei sugedus kreipkitės į pagalbos tarnybą.

LV - Apgaismošānas sistēmu lietotājs nevar nomainīt, darības traucējumu gadījumā sazinieties ar pēcpalīdzības servisu.

SR - Korisnik ne može da zameni sistem osvetljenja, u slučaju kvara kontaktirajte servisnu službu.

SL - Sistema razsvetljave uporabnik ne more zamenjati. V primeru nepravilnega delovanja se obrnite na servisno službo.

HR - Korisnik ne može zamijeniti sustav rasvjete, u slučaju kvara obratite se službi za prodaju.

TR - Aydınlatma sistemi kullanıcı tarafından değiştirilemez, arıza olması halinde teknik servise başvurulur.

AR - نظام الإضاءة غير قابل للاستبدال من قبل المستخدم، في حالة حدوث أعطال اتصل بخدمة المساعدة.

**In accordance with art. 26 of Italian Legislative Decree no. 49 of 14 March 2014**

**"Implementation of Directive 2012/19/EU, on waste electrical and electronic equipment (WEEE)"**

The crossed out bin symbol on the appliance or its packaging indicates that the product, at the end of its working life, must be collected separately from other waste.

The user should therefore deliver the product that has reached the end of its working life to the appropriate recycling centre for electrical and electronic waste.

Alternatively, the appliance to be disposed of can be returned to the retailer when purchasing a new equivalent product. Products with dimensions of less than 25cm can be returned free of charge and without obligation to purchase a new product to electronic product retailers that have a sales area of at least 400 sq. m.

The separate collection for the delivery of the used equipment for recycling, treatment and environmentally compatible disposal helps avoid possible negative effects on the environment and health and promotes the reuse and/or recycling of materials that make up the equipment.



