

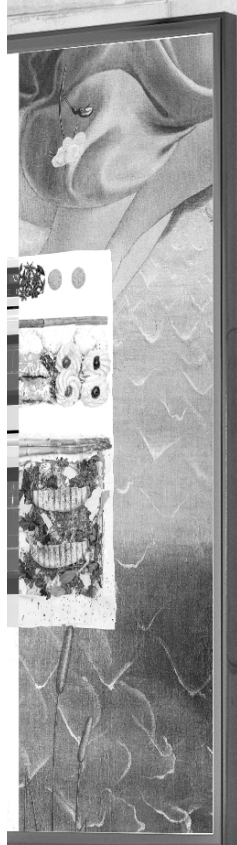

cooking

USAGE AND
CARE GUIDE

PRODUCT CODE:
EO8060DX



USER INSTRUCTIONS

GENERAL WARNINGS

Read carefully all the instructions contained in this booklet. It provides you with important information regarding the safe installation, use and maintenance of the appliance as well as useful advice for getting the best out of your oven. Keep this booklet in a safe place for future reference. After removing the packing, check that the appliance is not damaged in any way.

Be careful not to leave the packing materials (plastic sheeting, expanded polystyrene etc.) where children can get at them, as they can be dangerous.

IMPORTANT: do not use the oven door handle to move the appliance, such as to remove it from the packaging

ATTENTION

- **The oven is an appliance which, for its nature, becomes hot, especially in correspondence of the glass door.**
- **It is therefore a good rule that children do not approach the oven when it is functioning, particularly when the grill is used.**

The first time you switch the oven on, acrid smelling smoke may appear. This is caused by the heating of the adhesive used on the insulation panels surrounding the oven. There is nothing unusual about this. If it happens, simply wait until the smoke disappears before putting any food in the oven. Never roast or bake on the oven base.

Safety is a good habit to get into

- ⊙ This appliance is designed for non-professional, household use and its functions must not be changed.
- ⊙ The electrical system of this appliance may be used safely only when it is correctly connected to an efficient earthing system in compliance with the safety standards currently in effect.
- ⊙ The manufacturer will not be held liable for any damages that might arise out of incorrect installation or improper, incorrect or unreasonable use of the appliance.

The following items are potentially dangerous, and therefore, appropriate measures must be taken to prevent children and the disabled from coming into contact with them:

- Controls and the appliance in general;
- Packaging (bags, polystyrene, nails, etc.);
- The appliance immediately after use of the oven or grill due to the heat generated;
- The appliance when no longer in use (potentially dangerous parts must be made safe).

Avoid the following:

- Touching the appliance with wet parts of the body;
- Using the appliance when barefoot;
- Pulling on the appliance or the supply cord to unplug it from the electrical outlet;
- Obstructing the ventilation or heat dissipation slots;
- Allowing power supply cords for small appliances to come into contact with the hot parts of the appliance;
- Exposing the appliance to atmospheric agents (rain, sun);
- Using the oven for storage purposes;
- Using flammable liquids near the appliance;
- Using adaptors, multiple sockets and/or extension cords;
- Attempting to install or repair the appliance without the assistance of qualified personnel.

WARNING

- Accessible parts will become hot when in use. To avoid burns and scalds children should be kept away
- During usage, the appliance becomes hot, care should be taken to avoid touching heating elements inside the oven.

Qualified personnel must be contacted in the following cases:

- Installation (following the manufacture's instructions);
- When in doubt about operating the appliance;
- Replacing the electrical outlet when it is not compatible with the plug for the appliance.

Service Centers authorized by the manufacturer must be contacted in the following cases:

- If in doubt about the soundness of the appliance after removing it from the packaging;
- If the power supply cord has been damaged or needs to be replaced;
- If the appliance breaks down or functions poorly; ask for original spare parts.

It is a good idea to do as the following:

- Only use the appliance to cook food, nothing else;
 - Check the soundness of the appliance after it has been unpacked;
 - Unplugged the appliance from the electrical mains if it is not functioning properly and before cleaning or performing maintenance;
 - When the appliance is not used for an extended period of time, unplugged the appliance and close the gas cock (if present);
 - Use cooking gloves to place cookware in the oven or when removing it;
 - Always grasp the oven door in the centre because the ends may be hot due to the escape of hot air;
 - Make sure that the control knobs are on the “o” setting when the appliance is not in use;
 - Unplug the appliance when you decide not to use the appliance any longer.
 - If the supply cord is damaged, it must be replaced by the manufacturer, its service agent or similarly qualified persons in order to avoid a hazard.
- © The manufacturer may not be held responsible for any damage due to: incorrect installation, improper, incorrect and irrational use.
- © This appliance is not intended for use by persons (including children) with reduced physical, sensory or mental capabilities, or lack of experience and knowledge, unless they have been given supervision or instruction concerning use of the appliance by a person responsible for their safety. Cleaning and user maintenance shall not be made by children.

INDICATOR LIGHTS

The indicator lights situated above the control panel go on and off when the heating elements are inserted or removed. During the thermostatic functioning of the oven, the neon light remains on until the pre-chosen temperature is reached and when it goes out, this is a sign that the temperature has been reached. When the oven cools, the thermostat determines the re-insertion of the heating elements with consequent re-lighting of the indicator lights. In models the internal oven light, which is always on when any function is in operation, is considered as an operation, is considered as an operating warning light.

INSTALLING THE APPLIANCE

IMPORTANT: Unplug your oven before performing installation or maintenance!

Installation should be carried out according to the instructions by a professionally qualified person. The manufacturer declines all responsibility for any damage to persons, animals or things due to a wrong installation.

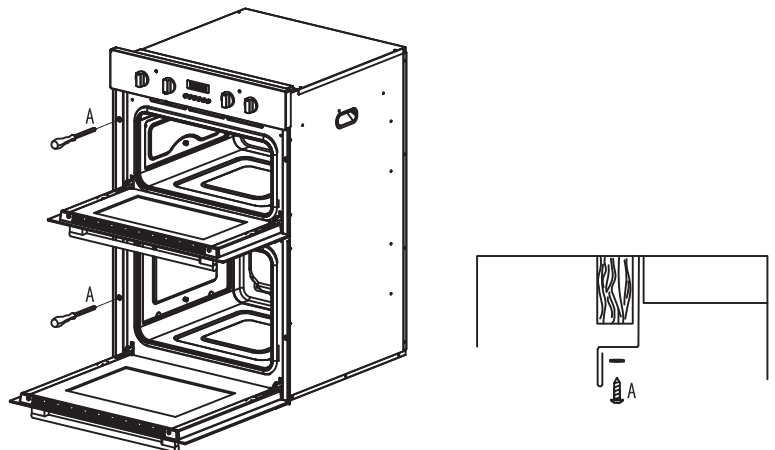
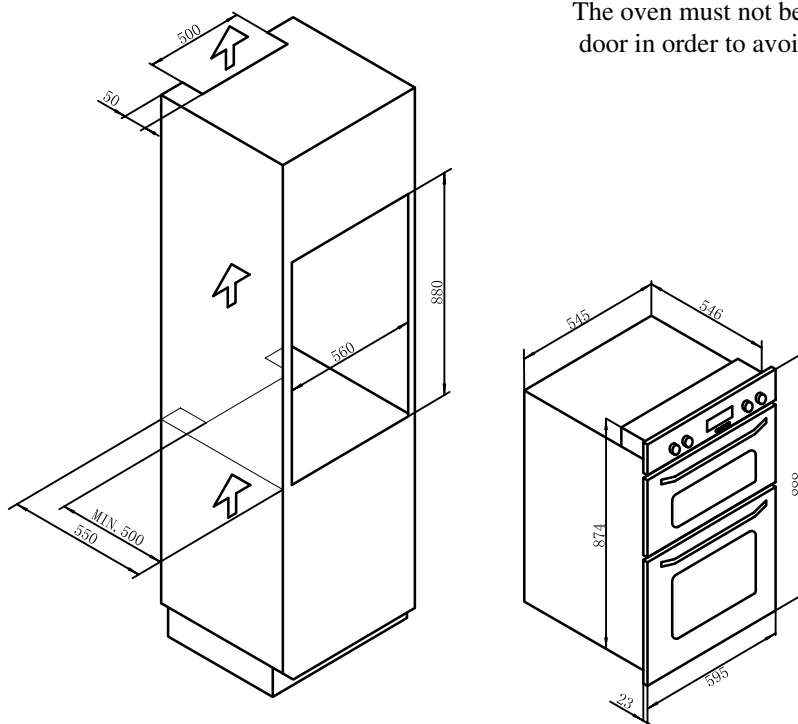

fig 3

Fitting the appliance

- Fit the appliance into its surround (beneath a work-top or above another appliance) by inserting screws into the 4 holes that can be seen in the frame of the oven when the door is open.
- For the most efficient air circulation, the oven should be fitted according to the dimensions shown in fig. 1-2
- The rear panel of the cabinet must be removed so that air can circulate freely. The panel to which the oven is fitted should have a gap of at least 70 mm at the rear.
- Openings at least 50mm deep must be cut both in the bottom and in the top of the unit to ensure adequate ventilation (see fig.1 for essential dimensions).

NB: where ovens are to be matched with hobs, it is essential to follow the instructions contained in the booklet supplied with the other appliance.



The oven must not be installed behind a decorative door in order to avoid overheating.

WARNING: THIS APPLIANCE MUST BE EARTHED

- Check that the power rating of the mains supply and of the sockets are suitable for the maximum power of the appliance as indicated on the specification plate.
- plug should be accessible after installation. Fit the plug into a socket fitted with a third contact which corresponds with the earth connection. This should be properly connected.
- If the appliance just fitted with supply leads but does not come already fitted with a plug, then permanently connect to fixed wiring as follow:

Electrical Connection

The appliance must be connected to the supply by way of an isolating switch with minimum contact separation of 3mm. Suitable isolating components include automatic breakers, fuses and relays.

The oven must be connected to an efficient earth system, as prescribed by national and/or local statutory regulations.

The terminal box is located at the rear of the appliance. If a new cable is fitted, route it through the clamp and make the connections as shown in the diagram. The earth wire must be cut longer than the other wires so that it will be the last to break off in the event of the cable being tugged.

Having made the connection, tighten the cable clamp and close the cover of the box.

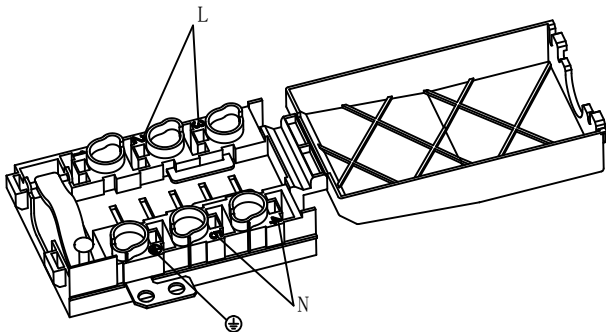

Control Panel

Top oven + main oven: 4 functions + 8 functions (without rotisserie)

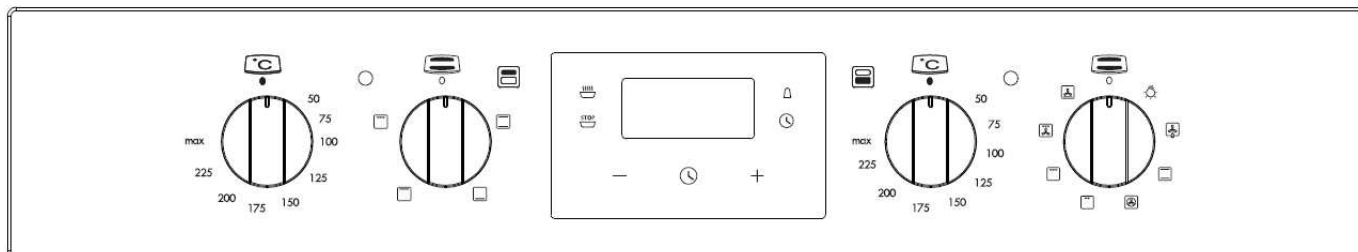

Top Oven Functions

The oven offers a basic choice between two types of cooking:

- A) conventional oven cooking
- B) grill (infrared radiant heat)

Selector functions:

Pls read functions according to your oven model.



Top outside+bottom heating element

Both the lower and upper heating elements operate together.

This is the traditional cooking, very good for roasting joints, ideal for biscuits, baked apples and crisping food. You obtain very good results when cooking on a shelf.



Bottom heating element

This function is particularly indicated for cooking from the bottom, warming up food or sterilizing glass jars. It is also indicated for food requiring long and slow cooking, i.e. casserole. This function can be used between 50 and MAX°C.



Top outside heating element

It is indicated for warming up pre-cooked food when placing the grid on the second shelf from the top, or for defrosting pastry placing the grid on the first shelf from the bottom. This function can be used between 50 and MAX°C.



Top outside+inside heating element

It is indicated for grilling and gratinating traditional food. This function must always be used with half-open door and control protection in position.

Main Oven Functions

The oven offers a basic choice between two types of cooking:

A) conventional oven cooking

B) grill (infrared radiant heat)

Selector functions:

Pls read functions according to your oven model.

	<u>Light in the oven</u>
	<u>Fan defrost</u> The air at ambient temperature is distributed inside the oven for defrosting food more quickly and without proteins adulteration.
	<u>Top outside heating element+bottom heating element</u> Both the lower and upper heating elements operate together. This is the traditional cooking, very good for roasting joints, ideal for biscuits baked apples and crisping food. You obtain very good results when cooking on a shelf
	<u>Fan+circle heating element</u> Both the fan and the circular heating element operate together. The hot air adjustable between 50 and MAX°C is evenly distributed inside the oven. This is ideal for cooking several types of food (meat, fish) at the same time without affecting taste and smell. It is indicated for delicate pastries.
	<u>Top inside heating element</u> It is indicated for grilling and gratinating small quantities of traditional food. This function can be used with closed door for very short times (5-10 minutes). For longer times, this function must always be used with half-open door and control protection in position.
	<u>Top inside+outside heating element</u> It is indicated for grilling and gratinating traditional food. This function must always be used with half-open door and control protection in position.
	<u>Top inside+outside heating element+fan</u> The air which is heated by the grill heating element is circulated by the fan and so helps to distribute the heat between 50 and 200°C. This function can be used for sterilizing glass jars.
	<u>Bottom heating element + fan</u> The air which is heated by the lower heating element is circulated by the fan and so helps to distribute the heat between 50 and 200°C. This function can be used for sterilizing glass jars.

Electronic Timer Setting (Touch Timer)



Operating instructions for Electronic Timer (3 keys)



Before using for the first time

Setting and changing the current time

i The oven only operates when the time has been set.



When the appliance has been connected to the electrical supply or when there has been a power cut, the function indicator Time  flashes automatically.

1. To change the time that has already been set, press the Selection  button repeatedly, until the function indicator Time  flashes.

2. Set the current time using the  or  button

After approx. 5 seconds, the flashing stops and the clock displays the time of day set.

The appliance is now ready to use.

i The time can only be changed if neither of the automatic functions (Cook time  or End time ) have been set.

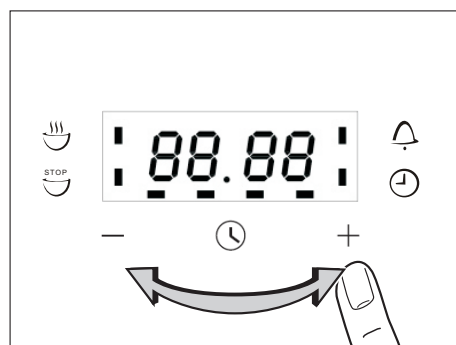
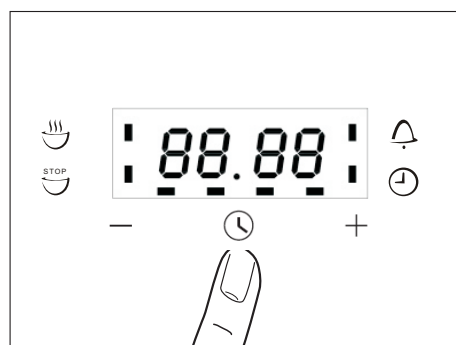

Clock Functions

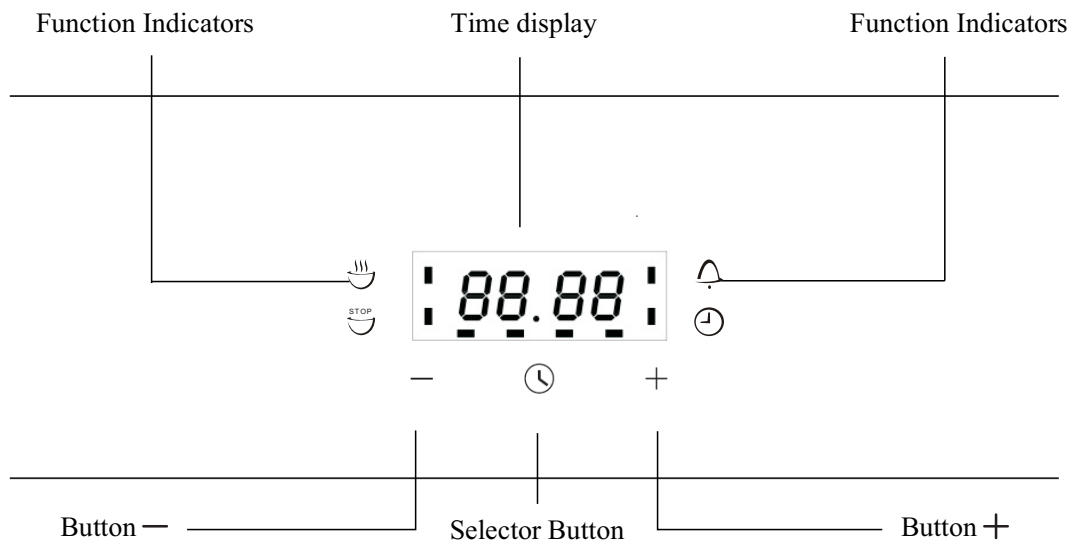

Countdown 🔔

To set a countdown, a signal sounds after the time has elapsed.

This function does not affect the operation of the oven.

Cook time 🔥

To set how long the oven is to be in use.

End time ⌚

To set when the oven is to switch off again.

Time ⌚

To set, change or check the time

(See also section “Before Using for the First Time”).



How to use the clock functions

- When a function has been selected, the corresponding function indicator flashes for approx. 5 seconds. During this time the desired times can be set using the or button.
- When the desired time has been set, the function indicator flashes for approx. another 5 seconds. After that the function indicator is then lit. The set time begins to run.
- Press any of the buttons to stop the acoustic signal.
- The desired oven function and temperature can be selected before or after the clock functions of Cook time and End time are set.
- When the cooking time has ended, turn the oven function and temperature dial back to the OFF position.

Switching off the Time Display

By switching off the time display you can save energy.

Switching off the time display

Hold down any two buttons until the display becomes dark.



Switching on the time display

Hold down any button until the time reappears in the display.



The display can only be switched off if none of the clock functions Cook time End time

or Countdown are in use.

Countdown

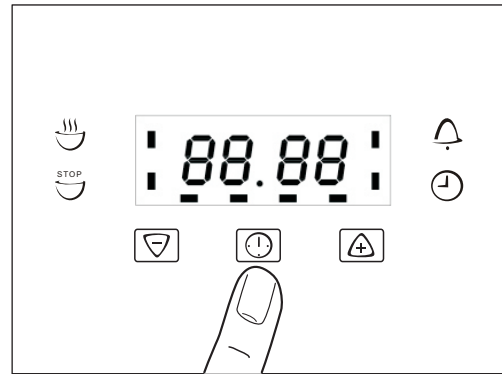
1. Press Selection  button repeatedly, until the function indicator Countdown  flashes.



2. Using the  or  button, set the required Countdown (m ax. 2 hours 30 minutes).

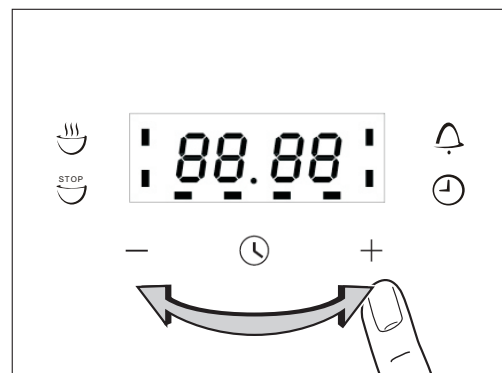

After approx. 5 seconds, the display shows the remaining time.

The function indicator Countdown  will light up.

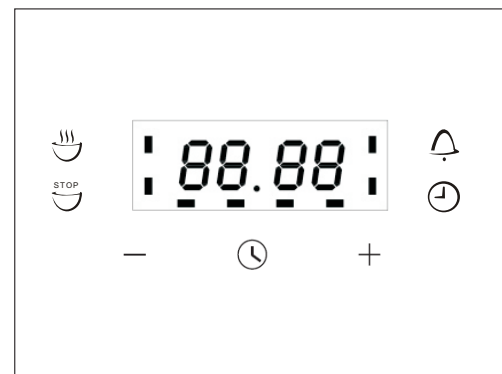

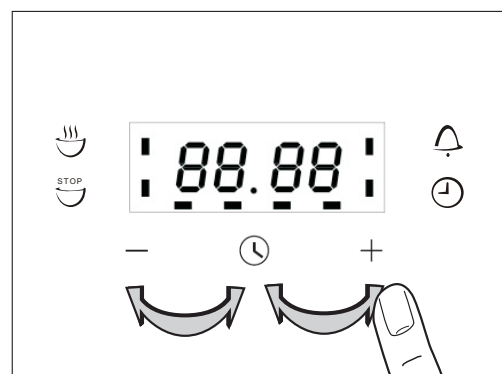

When the time has elapsed, the function indicator flashes and an acoustic signal sounds for 2 minutes.

Press any button to switch off the signal.



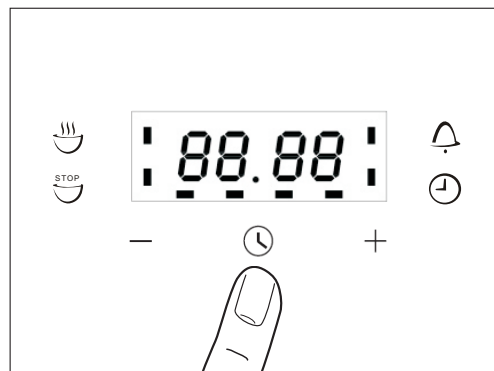

Cook time

1. Press Selection  button repeatedly, until the function indicator Cook time  flashes.

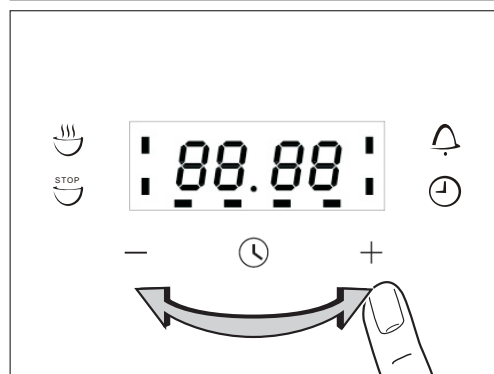

2. Using the  or  button, set the required cooking time.



After approx. 5 seconds, the display returns to the current time. The function indicator Cook time  will light up.

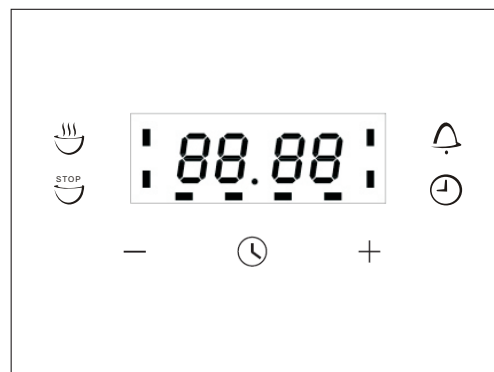



When the time has elapsed, the function indicator will flash, an acoustic signal will sound for 2 minutes and the oven will switch itself off.

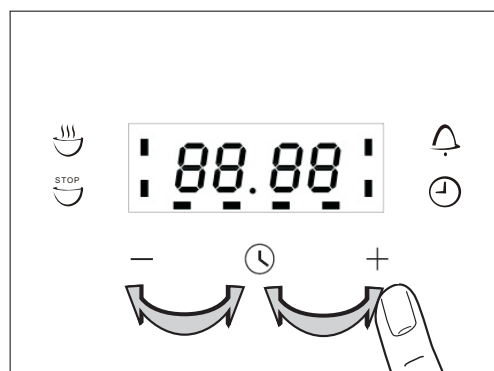

3. Press any button to switch off the signal and the program me.

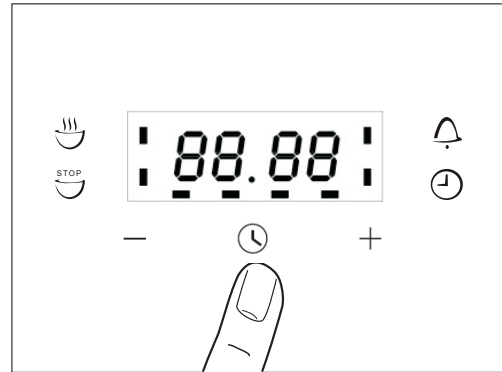

End time

1. Press Selection  button repeatedly, until the function indicator End time  flashes.



2. Using the  or  button, set the required switch-off time.

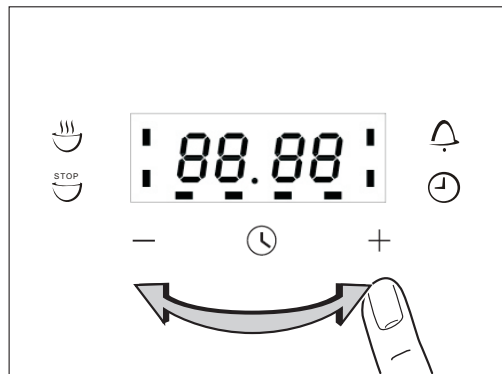

After approx. 5 seconds, the display returns to the current time.

The function indicator End time  will light up.

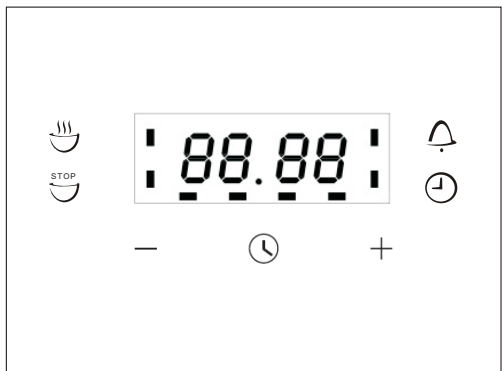

When the time has lapsed, the function indicator will flash, an acoustic signal will sound for 2 minutes and the oven will switch itself off.

3. Press any button to switch off the signal and the program me.

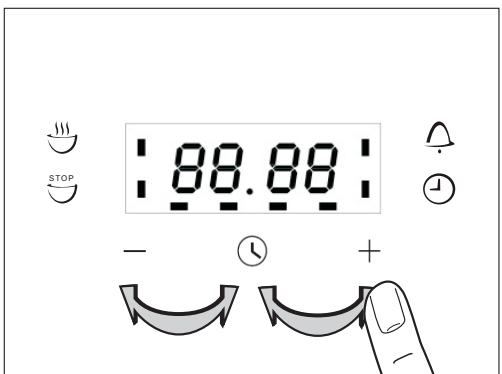

Technical Data

Dimension

height	888mm
width	595mm
depth	546mm
usable volume	42 + 60 litres

TOP oven

	nominal electrical input in W (toll. +5 / -10%)
Top outside heating element	750W
Top inside heating element	1000W
Bottom heating element	1050W
Light	15/25W
Maximum electrical input	1820W/230V

MAIN oven (8/9 functions)

	nominal electrical input in W (toll. +5 / -10%)
Top outside heating element	1000W
Top inside heating element	1900W
Circle heating element	2100W
Bottom heating element	1200W
Fan	25W
Light	15/25W
Rotisserie	4W
Maximum electrical input	2950W/230V

MAIN oven (4/5 functions)

	nominal electrical input in W (toll. +5 / -10%)
Top outside heating element	1000W
Top inside heating element	1900W
Circle heating element	2100W
Fan	25W
Light	15/25W
Rotisserie	4W
Maximum electrical input	2950W/230V

COOKING TABLE FOR TOP OVEN - CONVENTIONAL COOKING

IN HEATING SYSTEM WITH TOP AND BOTTOM HEATERS OPERATING. It is recommended to preheat the oven 10 min.

DISHES	LEVEL	TEMPERATURE	COOKING TIME
Yorkshire Puddin	1	200°C	30 - 40 min
Fatless Sponge Cake	1	180°C	25 - 30 min
Small Cakes	2	190°C	15 - 20 min
Fruit Plate Tart	1	200°C	40 - 45 min
Scones	2	220°C	10 - 15 min
Rich Fruit Cake	1	140°C	2 - 3 hours

COOKING TABLE FOR THE TOP OVEN WITH INFRARED HEATER OPERATING

Grilling is carried out at the door closed. 5 minutes oven preheating is recommended. Setting possibility from 50 - max (250)°C. Food is placed on the backing pan grid.

DISHES	LEVEL	TEMPERATURE	COOKING TIME	
			Side 1	Side 2
Pork steaks, Chops (4 pcs)	3	225°C	12 min	10 min
Grilled Sausages (6 pcs)	3	225°C	6 min	5 min
Toast (6 pcs)	3	225°C	1 min/25 sec.	1 min/10 sec.

COOKING TABLE FOR THE MAIN OVEN WITH INFRARED HEATER OPERATING

Grilling is carried out at the door closed. 5 minutes oven preheating is recommended. Setting possibility from 50 - max (250)°C. Food is placed on the backing pan grid.

DISHES	LEVEL	TEMPERATURE	COOKING TIME	
			Side 1	Side 2
Pork steaks, Chops (4 pcs)	Topmost 5	250°C	15 min	12 min
Roast beef (4pcs)	Topmost 5	250°C	10 min	8 min
Grilled Sausages (6 pcs)	Topmost 5	250°C	9 min	6 min
Toast (6 pcs)	Topmost 5	250°C	1 min/50 sec.	1 min/30 sec.

USING THE OVENS



Set the selector for the type of cooking required.

Preheat the oven, setting the thermostat to the required temperature. Once the oven has heated to the selected temperature, the orange warning light will go out. This same light will appear again automatically during operation of the oven to indicate that the heating elements are on.

Remove the drip tray when using the oven for conventional baking, roasting etc. The tray should be left in place only when using the grill, as its purpose is to catch falling droplets of fat. Food should be placed in oven dishes with raised edges and positioned centrally under the grill. If fan-forced operation is selected, foods of different types can be cooked simultaneously (e.g. meat and fish), although in this case the respective cooking time must be observed.

If selecting the  position, temperatures must be set 10 to 20°C lower than indicated in the table.

Cooking temperatures and times

Dish	Temperature in degrees centigrade	Approximate cooking time in minutes
	 	
Sweets	175 160	55-65
Short pastry flan base	200 190	8-10
Fruit pie/tart	200 190	25-35
White leavened bread per 1 kg flour	200 190	30-50
Shortcake biscuits	200 190	10-15
Savoury biscuits	200 190	15-20
Lasagne	225 210	40-50
Meat (cooking time based on thickness)		
Slow roast	175 170	12-15
Quick roast	200 190	12-15
Meat loaf	200 190	30-40
Poultry		
Duck 1.5 -2 kg	200 170	120-180
Goose 3 kg	200 180	150-210
Roast chicken	200 190	60-90
Turkey 5 kg	175 150	240 ca.
Game		
Hare	200 180	60-90
Leg of roebuck	200 180	90-150
Haunch of venison	175 175	90-180
Vegetable		
Vegetable soufflé	200 180	40-45
Fish	180 170	40-45
Pizza	210 200	20-25
Grills		
Pork chop		8-12
Sausage		10-12
Grilled chicken		25-35

ROASTING GUIDE

- Frozen meat should be thoroughly thawed before cooking. For large joints it is advisable to thaw overnight.
- Frozen poultry should be thoroughly thawed before cooking, the time required depends on the size of the bird e.g. a large turkey may take up to 48 hours to thaw.
- Adjust the shelf position so the meat or poultry will be in the centre of the oven.

The TIMES given in the ROASTING GUIDE are only approximate because the size and age of the bird will influence cooking times as will the shape of a joint and the proportion of bone.

Cook in oven 180°C (Fan oven) 200°C (Conventional oven)		Approximate cooking time
BEEF	Rare Medium Well Done	20 minutes per 450g. (1lb) plus 20 minutes 25 minutes per 450 g (1 lb) plus 20 minutes 30 minutes per 450 g (1 lb) plus 30 minutes
LAMB	Medium Well Done	25 minutes per 450 g (1 lb) plus 25 minutes 30 minutes per 450 g (1 lb) plus 30 minutes
PORK		35 minutes per 450 g (1 lb) plus 35 minutes
FOWL		20 minutes per 450 g (1 lb) plus 20 minutes

Notes:

If you are cooking a very large turkey e.g. over 141lb., we recommend that it is turned around halfway through cooking, so that both legs will be cooked evenly. Remove any excess fat from the tin before turning, to prevent any fat splashing. When cooking stuffed meat or poultry calculate the cooking time from the total weight of the meat plus the stuffing.

For joints cooked in foil or covered roasters, and for lidded casseroles, add 5 minutes per 450g. (1lb. to the calculated cooking time.

Smaller joints weighing less than 1.25 k.g. (2 lb.) may require 5 minutes per 450g. (1lb) extra cooking time.

How to keep Your Oven in Shape

This appliance is for household use only, don't use it outdoors!

Important: Unplug your oven before cleaning, or performing maintenance!

To extend the life of your oven, it must be cleaned frequently, keeping in mind that:

- ⦿ **Do not use steam equipment to clean the appliance.**
- ⦿ To protect against the risk of electrical shock, do not immerse the unit, cord or plug in water or other liquid or sprinkle water to clean the appliance!
- ⦿ Don't clean the appliance when it is still hot! The inside and external surface of the oven should preferably be cleaned by damp cloth when it is cooled down.
- ⦿ Wash all accessories in hot sudsy water or in a dishwasher, wipe dry with a paper or cloth towel.
- ⦿ If you use your oven for an extended period of time, condensation may form. Dry it using a soft cloth.
- ⦿ There is a rubber seal surrounding the oven opening which guarantees its perfect functioning. Check the condition of this seal on a regular basis. If necessary, clean it and avoid using abrasive products or objects to do so. Should it become damaged, please contact your nearest After-sales Service Centre. We recommend you avoid using the oven until it has been repaired.
- ⦿ Never line the oven bottom with aluminium foil, as the consequent accumulation of heat could compromise the cooking and even damage the enamel.
- ⦿ Clear the glass door using damp cloth and dry it with a soft cloth.

Do not use harsh abrasive cleaners or sharp metal scrapers to clean the oven door glass since they can scratch the surface, which may result in shattering of the glass.

Replacing the Lamp in the Oven

- ⦿ Unplug your oven!
- ⦿ Unscrew the glass cover attached to the lamp holder;
- ⦿ Unscrew the lamp and replace it with another high-temperature lamp (300°C) with the

following characteristics:

- Voltage: AC220V-240V
- Wattage: 15W
- Socket: E 14

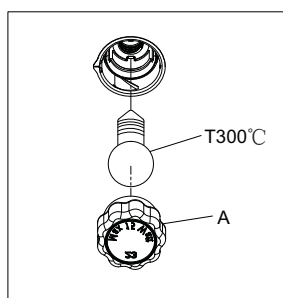

- ⦿ Remount the glass cover and reconnect the appliance to the power supply.

WARNING: Ensure that the appliance is unplugged before replacing the lamp to avoid the possibility of electric shock.

Warning: Do not operate appliance with damaged cord or plug or after the appliance malfunctions, or has been damaged in any manner, return appliance to the nearest Authorized Service Center for examination. Repair, or adjustment!

USEFUL NOTES FOR COOKING

In the following table, some indicative hints for cooking:

FAULTS	CAUSES	REMEDIES
The upper crust is dark and the lower part too pale	Not enough heat from the bottom	<ul style="list-style-type: none"> - Use the natural convection position - Use deeper cake tins - Lower the temperature - Put the cake on a lower shelf
The lower part is dark and the upper crust too pale	Excessive heat from the bottom	<ul style="list-style-type: none"> - Use the natural convection position - Use lower side tins - Lower the temperature - Put the cake on a higher shelf
The outside is too cooked and the inside not cooked enough	Too high temperature	<ul style="list-style-type: none"> - Lower the temperature and increase the cooking time
The outside is too dry even though of the right color	Too low temperature	<ul style="list-style-type: none"> - Increase the temperature and reduce the cooking time.

Protective kit

During operation, the oven glass door and adjacent parts of the appliance become hot. Make sure, therefore, that children do not touch the appliance.

This appliance is not intended for use by persons (including children) with reduced physical, sensory or mental capabilities or lack of experience and knowledge, unless they have been given supervision or instruction concerning use of the appliance by a person responsible for their safety.

Children should be supervised to ensure that they do not play with the appliance.

For greater safety, an additional child-safety device is available from our Head Office and our Authorised Service Centres (see enclosed list). When ordering this, please give the code: BAB-followed by the appliance model. The model is stamped on the plate which is visible on the front part of the oven upon opening the door.

Disassembling/assembling the oven door

To make it easier to clean the inside of your oven, the oven door can be removed, by proceeding as follows (fig. 11):

- Open the door completely and lift the 2 levers “B” (fig.11-1);
- Now, shutting the door slightly, you can lift it out by pulling out the hooks “A” as shown in figure 2.

To reassemble the door:

- With the door in a vertical position, insert the two hooks “A” into the slots;
- Ensure that seat “D” is hooked perfectly onto the edge of the slot (move the oven door backwards and forward slightly);
- Keep the oven door open fully, unhook the 2 levers “B” downwards and then shut the door again.

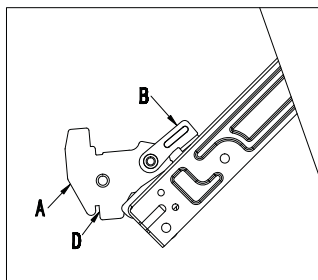

Fig.11-1

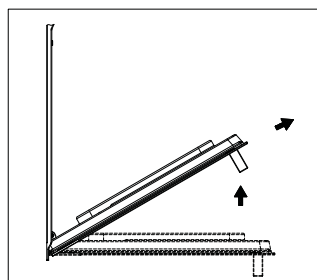

Fig.11-2

Instruction of Removable Glazing Door

The oven door is made up of 3 panes of glass and has vents at the top and bottom. When the oven is operating,

air is circulated through the door to keep the outer pane cool. If condensation has worked its way in between the

glass panes, the door can be dismantled in order to clean in between the panes.

Remove the door as per above instruction and place it on a protective surface (e.g. on a table cloth) to prevent it

getting scratched. The door handle should line up with the edge of the table. Make sure the glass lies flat to avoid

breakage of glass during cleaning.

1. Undo the 2 screws on upper bracket.
2. Take out upper bracket and first pane of glass.
3. Loosen the 4 clips.
4. Slide out middle pane of glass carefully. Clean the glass panes and other parts with a damp microfibre cloth or a clean sponge and a solution of hot water with a little washing-up liquid. Wipe dry using a soft cloth.

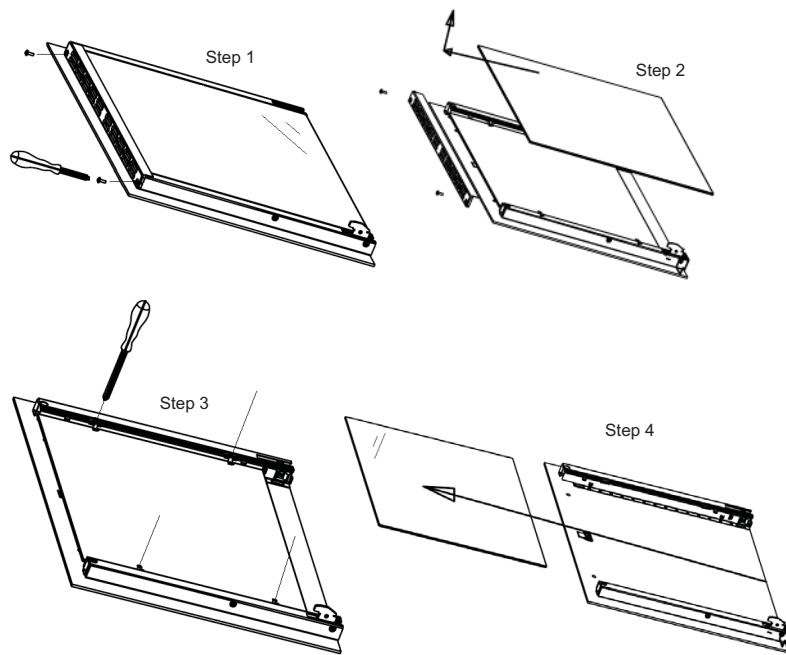

Fitting Oven Shelves

1. Ensure shelf orientation is correct (refer picture below)
2. Slide into oven at an angle until raised back of shelf is past the stop on side runners.
3. Lower front of shelf and push in until stop is reached.
4. To remove oven shelves, withdraw to the stop and raise the front of shelf to clear the stop.

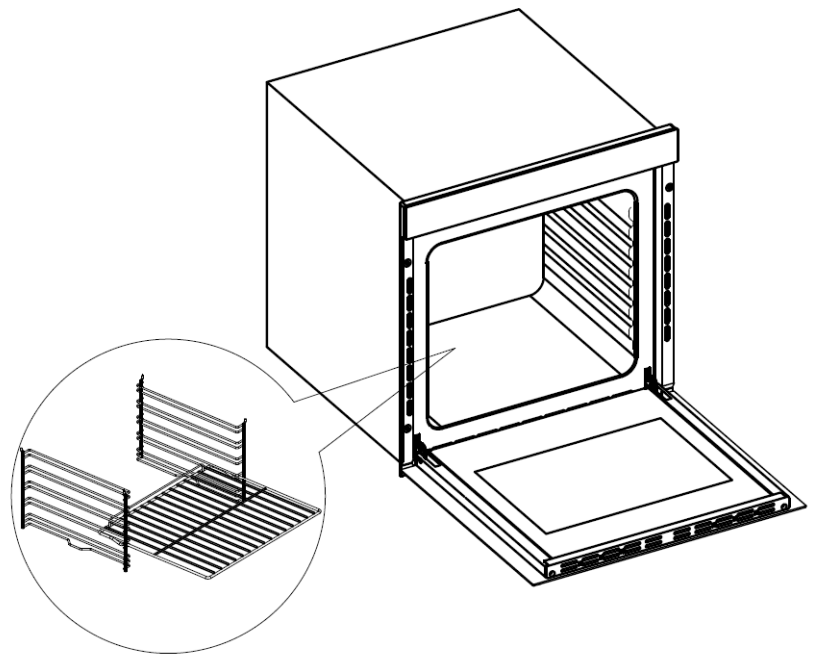

This product must not be disposed together with the domestic waste. This product has to be disposed at an authorized place for recycling of electrical and electronic appliances. By collecting and recycling waste, you help save natural resources, and make sure the product is disposed in an environmental friendly and healthy way.

Important: if you decide not to use the oven any more, it should be made inoperable by cutting the power supply cable, after unplugging it from the power supply. Disused appliances can be a safety risk as children often play with them. For this reason it is advisable to make the oven safe.



Pronto Service + Support: 1800 440 335
Email: service@eurostylegroup.com.au

HEAD OFFICE
65 Glynburn Road, Glyne SA 5070
Ph: 08 8165 1012

www.euroappliances.com.au

