

Shark **CarpetXpert** **HairPro Pet**

EX220 Series

OWNER'S GUIDE

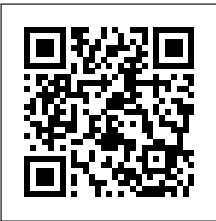

Scan QR code to view
HOW-TO VIDEOS
and more.

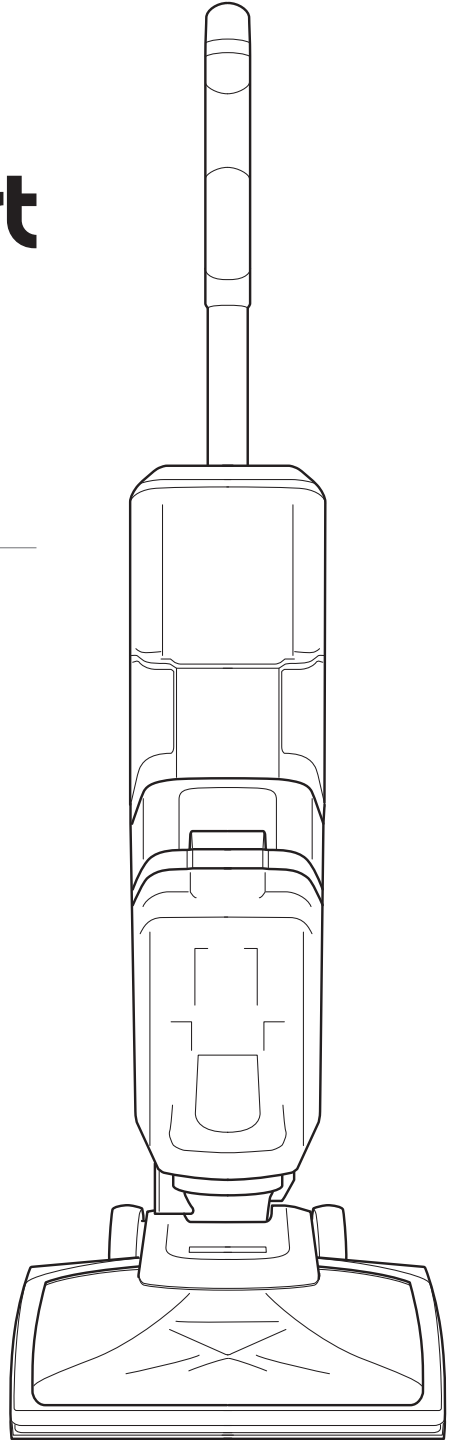

THANK YOU

for purchasing the Shark CarpetXpert HairPro Pet



TIP: You can find the model and serial numbers on the QR code label located on the back of your unit.

REGISTER YOUR PURCHASE

TO BENEFIT FROM YOUR PRODUCT'S EXTENDED GUARANTEE, SIMPLY REGISTER YOUR PURCHASE AT:



sharkclean.co.uk/register-guarantee



+44 (0)800 862 0453



Scan QR code using mobile device

Please note, products purchased directly from Shark are automatically registered.

Benefits of registering your product and creating an account:

- Get easier, faster product support and access to guarantee information
- Access troubleshooting and product care instructions
- Be among the first to know about exclusive product promotions

RECORD THIS INFORMATION

Model Number: _____

Serial Number: _____

Date Code: _____

Date of Purchase (Keep Receipt): _____

Store of Purchase: _____

TECHNICAL SPECIFICATIONS

Voltage: 220-240V~ 50-60 Hz

Watts: 1000W

PLEASE READ CAREFULLY AND KEEP FOR FUTURE REFERENCE.

This instruction manual is designed to help you get a complete understanding of your new Shark CarpetXpert Hair Pro Pet.

If you have any questions, please call the customer service line on +44 (0)800 862 0453.



CONTENTS

Important Safety Instructions	4
What's Included	6
Assembly	7
Cleaning Solution and Tank	
Shark Cleaning Solution.....	8
How to use CarpetXpert HairPro Pet	
Cleaning with CarpetXpert	9
Maintenance	
Cleaning the Dirty Water Tank	11
Cleaning the Brush-Roll	11
Cleaning the Diverter Valve.....	12
Indicator Lights	13
Troubleshooting	13
Guarantee	14



This marking indicates that this product should not be disposed with other household wastes. To prevent possible harm to the environment or human health from uncontrolled waste disposal, recycle it responsibly to promote the sustainable reuse of material sources. To return your used device, please use the return and collection systems or contact the retailer where this product was purchased. They can take this product for **environmentally safe recycling**.

IMPORTANT SAFETY INSTRUCTIONS

FOR HOUSEHOLD USE ONLY • PLEASE READ ALL INSTRUCTIONS BEFORE USING THIS CARPET EXTRACTOR.

To reduce the risk of shock and unintended operation, turn off power before servicing. If the supply cord is damaged, it must be replaced by the manufacturer, its service agent, or similarly qualified persons in order to avoid a hazard.

⚠ WARNING

REDUCE THE RISK OF FIRE, ELECTRIC SHOCK, INJURY, OR PROPERTY DAMAGE:

1. If the power cord plug does not fit fully into the socket, contact a qualified electrician. **DO NOT** force into socket or try to modify to fit.
2. To reduce the risk of shock and unintended operation, unplug before servicing.
3. This carpet cleaner consists of a motorised nozzle, main body, pole and handle. Some of these components contain electrical connections, electrical wiring, and moving parts that potentially present risk to the user.
4. Before each use, carefully inspect all parts for any damage. If a part is damaged, discontinue use.
5. Use only identical Shark® replacement parts.
6. **DO NOT** use the carpet cleaner for any purpose other than those described in this booklet.
7. **DO NOT** immerse or spray water on the body of the carpet cleaner. To clean the surface, wipe with a dry cloth.
8. Keep the carpet cleaner's cord out of reach of children.
9. **DO NOT** allow the appliance to be used by children. **DO NOT** allow to be used as a toy. Close supervision is necessary when used near children. Cleaning and user maintenance must not be done by children.
10. This appliance can be used by persons with reduced physical, sensory or mental capabilities or lack of experience or knowledge if they have been given supervision or instruction concerning use of the appliance in a safe way and understand the hazards involved.
11. **DO NOT** handle plug or carpet cleaner with wet hands.
12. **DO NOT** use without the dirty water tank, clean solution tank, filter, brushroll, and brushroll cover in place.
13. Only use Shark® branded filters and accessories.
14. **DO NOT** put any objects into nozzle opening. **DO NOT** use with any opening blocked; keep free of dust, lint, hair, and anything that may reduce airflow.
15. **DO NOT** use if nozzle airflow is restricted. If the air paths or the motorised floor nozzle become blocked, turn the carpet cleaner off. Remove all obstructions before you turn on the unit again. Keep nozzle and all carpet cleaner openings away from hair, face, fingers, uncovered feet, or loose clothing.
16. **DO NOT** use if carpet cleaner is not working as it should, or has been dropped, damaged, left outdoors, or dropped into water.
17. Use extra care when cleaning on stairs.
18. **DO NOT** leave the carpet cleaner unattended while plugged in.
19. When using on any surface, always keep the carpet cleaner moving to avoid damaging the surface (e.g., carpet fibres).
20. **DO NOT** place carpet cleaner on unstable surfaces such as chairs or tables. The surrounding area may be slippery and present a risk of injury.
21. **DO NOT** use to pick up:
 - a) Large objects.
 - b) Hard or sharp objects (glass, nails, screws, or coins).
 - c) Large quantities of dust (e.g., drywall dust).
 - d) Smoking or burning objects (hot coals, cigarette butts, or matches).
 - e) Flammable or combustible materials (lighter fluid, petrol, or kerosene).
 - f) Toxic materials (chlorine bleach, ammonia, or drain cleaner).
22. **DO NOT** use in the following areas:
 - a) Poorly lit areas.
 - b) Outdoor areas.
 - c) Spaces that are enclosed and may contain explosive or toxic fumes or vapours (lighter fluid, petrol, kerosene, paint, paint thinners, mothproofing substances, or flammable dust).
23. The plug must be removed from the socket-outlet before any adjustment, cleaning or maintenance of the appliance.

24. During cleaning or routine maintenance, **DO NOT** cut anything other than hair, fibres, or string wrapped around the brushroll.
25. **DO NOT** modify or attempt to repair the carpet cleaner yourself. **DO NOT** use the carpet cleaner if it has been modified or damaged.
26. Turn off all controls before unplugging.
27. To reduce the risk of fire or electric shock due to internal component damage, use only Shark® cleaning solution. See the Cleaning Fluid section of this Instruction Booklet.
28. **DO NOT** pull or carry by cord, use cord as a handle, close a door on cord, or pull cord around sharp edges or corners. **DO NOT** run appliance over cord. Keep cord away from heated surfaces.
29. **DO NOT** unplug by pulling on cord. To unplug, grasp the plug, not the cord.
30. Use indoors only.
31. **DO NOT** use carpet cleaner on hard floors or wool as it may damage your floor. To avoid damage to flooring and to avoid potential slip hazard, after use: (a) move to a hard sealed surface (avoid unsealed, wood and laminate) and (b) place unit on absorbent material like a towel to soak up any liquid.
32. **DO NOT** fill solution tanks while installed on the appliance. Remove before filling.
33. **DO NOT** use vinegar in any tanks.
34. The areas around where you are cleaning may become wet, use care to avoid slipping and falling.
35. Improper connection of the equipment grounding conductor can result in a risk of electric shock. Check with a qualified electrician or service person if you are in doubt as to whether the socket is properly grounded. **DO NOT** modify the plug provided with the appliance. If the plug will not fit the socket, have a proper socket installed by a qualified electrician.
36. This appliance is for use on a nominal V circuit and has a grounding attachment plug that looks like the plug illustrated below. Make sure that the appliance is connected to a socket having the same configuration as the plug. No adaptor should be used with this appliance.
37. **DO NOT** immerse. To reduce risk of electric shock, use only on carpet moistened by cleaning.
38. **DO NOT** run over edges of area rugs.
39. Stalling the brush roll may result in premature belt failure.
40. Avoid repeated strokes over the same area, to help prevent damage to Berber/ Loop Pile carpets.
41. Check manufacturer's tag prior to cleaning area rugs for any specific cleaning guidelines. We **DO NOT** recommend deep cleaning delicate rugs (including silk, antique, or area rugs that **DO NOT** have a manufacturer's tag).
42. **DO NOT** store unit where temperatures reach freezing levels to avoid damaging internal parts.
43. **FIRST AID** Keep out of reach of children. Causes skin and serious eye irritation. **IF IN EYES**, rinse continuously with water for minutes. Remove contact lenses if present and easy to do so. Continue rinsing. **IF ON SKIN**, wash with soap and water. If skin and eye irritation persists, seek medical attention. Please recycle container. Dispose of contents/container with a licensed waste disposal site in accordance with the requirements of the local waste disposal authority. **DO NOT** dispose in drains or watercourses in concentrate form.
44. The appliance is not to be used by persons (including children) with reduced physical, sensory or mental capabilities, or lack of experience and knowledge, unless they have been given supervision or instruction.
45. Children being supervised not to play with the appliance.
46. If the supply cord is damaged, it must be replaced by the manufacturer, its service agent or similarly qualified persons in order to avoid a hazard.
47. The plug must be removed from the socket-outlet before cleaning or maintaining the appliance.
48. A liquid dispensing system shall specify the amount and type of the liquid to be used.

SAVE THESE INSTRUCTIONS

WHAT'S INCLUDED

Shark CarpetXpert, 355ml. Shark Deep Clean Pet Solution

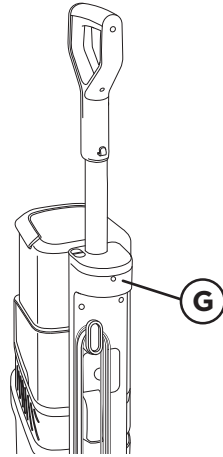
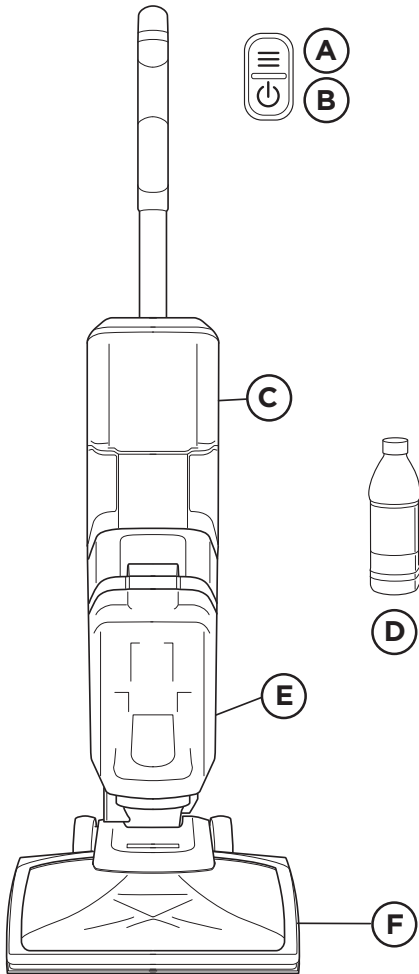

- A** Mode Button
- B** Power Button
- C** CarpetXpert Tank
- D** 355ml Deep Clean Pet
- E** Dirty Water Tank
- F** Floor Nozzle
- G** Carry Handle

ASSEMBLY

Note: When assembling your CarpetXpert, there may be a little water in or around the water tanks. This is because we test all units before shipping to ensure the highest quality.

1. Insert the pole into the top of the unit until it clicks into place (**fig. 1**). Make sure the pole is properly installed to prevent it from falling out during use.
2. Be sure the rubber seal is seated in place under the dirty water tank (**fig. 3**).
3. Make sure that the dirty water tank is fully inserted. Remove the tank and reinstall by placing the bottom of the tank on the bottom edge of the main unit (**fig. 4**) and tilting the tank back until it clicks into place.

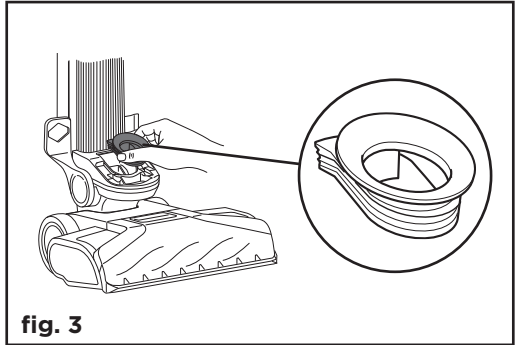
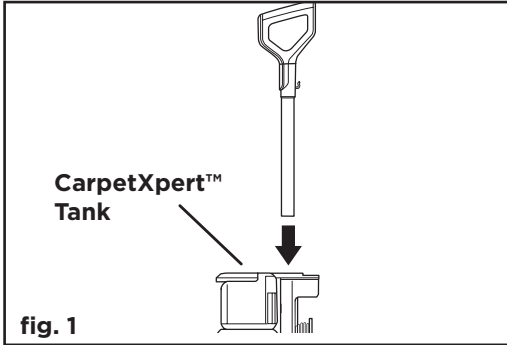

SHARK CLEANING SOLUTION

Shark Cleaning Solutions

The cleaning solution tank is designed to work with Shark cleaning solutions ONLY. To order refills, scan the QR code located on the bottom of the CarpetXpert Tank or at the bottom of this page. **Do not** use third party or homemade cleaners.



Shark Deep Clean Pet
Dispensed from the CarpetXpert tank. Used for deep-cleaning carpets and upholstery.

1. Filling the CarpetXpert Tank (top tank). ①

- Lift the CarpetXpert tank by the handle to detach it, then remove cap by unscrewing it.
- Add warm water to the tank up to the WATER fill line. Do not use water hotter than 60°C (140°F).
- Add Shark Deep Clean Pet up to the CONCENTRATE fill line.
- Reattach the cap, then reinstall the CarpetXpert tank, making sure it securely clicks into place.

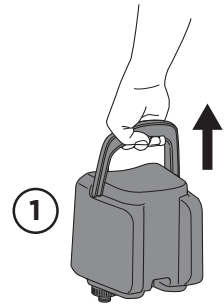

Tip: Use carry handle on the back of unit **(G)** for easy transport on stairs. To reduce carry weight, fill tank after moving unit to the area you are cleaning.

Tip: If you use your CarpetXpert often, then it's okay to leave any remaining solution in the tank until next time. If you don't use your CarpetXpert for an extended time (for example, 6 months) then the solution might need to be replaced.

To order cleaning solutions, scan the QR code or go to sharkclean.co.uk



DEEP CLEANING WITH CARPETXPERT

DEEP CLEANING with the brushroll: *Uses Deep Clean Pet Formula and water.*

Important: *CarpetXpert is not a vacuum cleaner and is not designed for dry vacuuming. Before using CarpetXpert, first remove pet hair and other debris with a traditional vacuum cleaner.*

1. Gently step on the floor nozzle and tilt the handle back.
2. Press power button; unit will enter Deep Clean Mode.
3. Move unit forward; it will automatically dispense water and Deep Clean Pet formula.
4. Move unit back to dry with suction only (does not dispense fluid on back stroke).
5. Repeat steps 3 and 4 on the same area once.

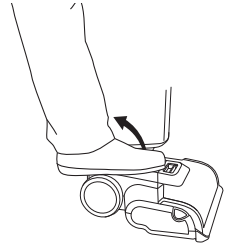

Tip: Carpet cleaners are designed to move slower than a traditional vacuum. For best results, push and pull CarpetXpert at intervals of a few feet in a slower pace than you would a vacuum.

Tip: To cover more square footage per tank, avoid cleaning the same area with more than two passes per session.

WARNING: Moving too slowly will oversaturate carpets. When Deep Clean Mode is activated, keep the floor nozzle moving. Do NOT let it remain in one place. Do NOT clean the same area more than two times in Deep Clean Mode.

WHILE IN DEEP CLEAN MODE

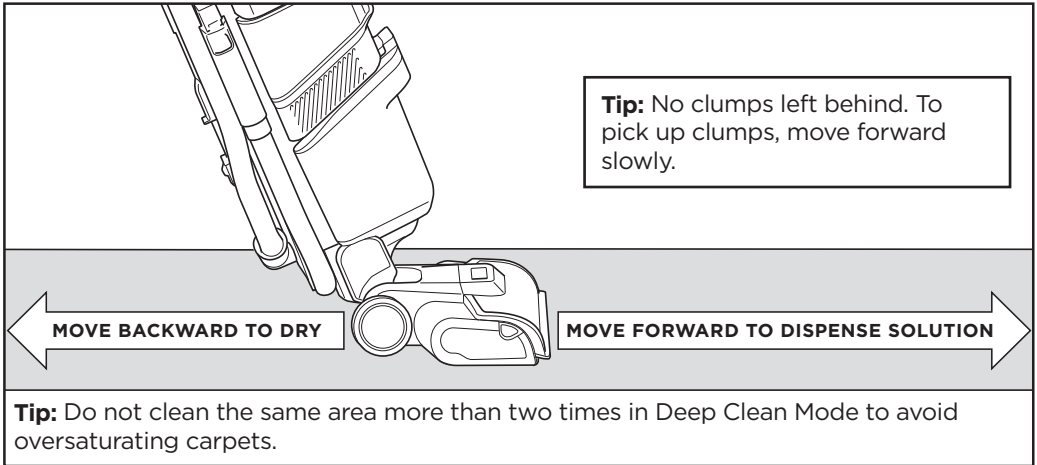

Tip: Do not clean the same area more than two times in Deep Clean Mode to avoid oversaturating carpets.

Rinsing: You may want to rinse your carpet after cleaning. To do this, fill CarpetXpert Tank with only water, and repeat cleaning steps.

Dry Only Mode

After deep cleaning is complete, it may take a few hours for the carpet to dry. For quicker dry times, use Dry Only Mode. This mode will turn off liquid and will dry as the nozzle moves forward and backward.

Note: Dry Only Mode should ONLY be used after Deep Cleaning Mode. You do not need to switch back and forth between the two modes while cleaning. Using Dry Only Mode once Deep Cleaning is complete will help reduce dry times.

Area Rugs

Check manufacturer's tag prior to cleaning and follow all guidelines. We **DO NOT** recommend cleaning delicate rugs (including wool, cotton, silk, antique, or rugs that **DO NOT** have a manufacturer's tag).

We recommend first testing a small, hidden part of the rug to make sure it is okay to clean.

Tip: Be mindful of edges when cleaning area rugs. If your area rug has decorative or loose fibers, do not run CarpetXpert near edges.

MAINTENANCE

Tip: Clean unit after every use to avoid odours, bacteria, and mold.

Note: When turning off the power, it will take 2 to 3 seconds for the unit to clear the lines and power down completely.

DIRTY WATER TANK

Note: When the dirty water tank is full, there will be a change in motor noise or airflow, and the indicator light will flash blue. The CarpetXpert unit will also turn off.

1. Press the release button and remove the tank (**fig. 1**).
2. Lift out lid with float (**fig. 2**). **DO NOT** pour out dirty water until float is fully removed.
3. Pour dirty water from the tank down a drain (**fig. 3**).
4. Dump hair and debris out of the non-removeable hair cage into the trash (**fig. 4**). Rinse the dirty water tank and the hair cage inside.
5. Remove the filter cover, then lift out the filter. Wash the filter with soap and water, then allow it to air-dry completely before reinstalling.
6. Be sure to return the filter to the dirty water tank before reinstalling it. For long-term storage, allow tank to air-dry completely before reinstalling it.

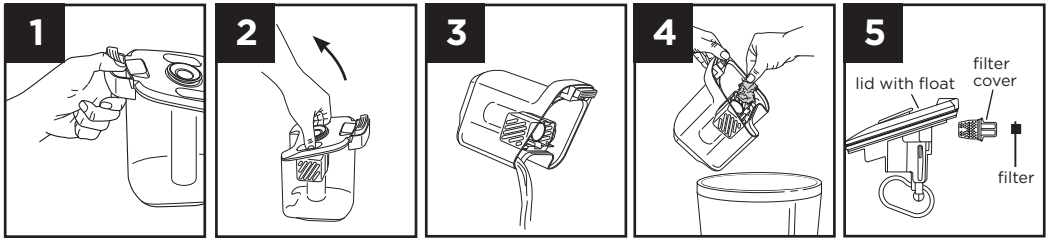

BRUSHROLL

1. Pull the latch to remove nozzle cover (**fig. 1**).
2. Open the brushroll cover by lifting it by the tabs marked **PULL** (**fig. 2**).
3. Remove the brushroll by pulling up on the side tab (**fig. 3**). If hair is wrapped, cut it away by running scissors along the groove in the brushroll. Rinse brushroll and both covers and allow them to air-dry before reinstalling.
4. To reinstall the nozzle cover, connect the 2 hooks at the bottom, then push forward until it clicks into place (**fig. 4**).

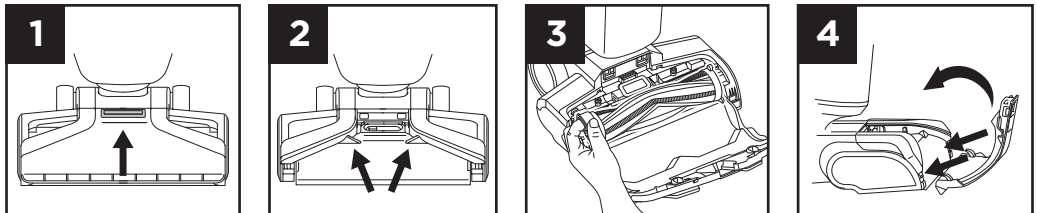

Note: Use a paper towel to wipe away any debris on interior of the brushroll cover.

CLEANING THE DIVERTER VALVE

Clean the diverter valve behind the brushroll if you are doing a deep clean of the CarpetXpert unit.

1. Remove the brushroll **(fig. 1)**.
2. Press the release button at the top of the diverter valve **(fig. 2)**, then pull out the valve **(fig. 3)**.
3. Use a damp cloth or paper towel to wipe away any debris on the valve or in the opening.
4. Rinse the valve and wipe with paper towel before reinserting to unit.
5. Reinsert the valve and secure it by pushing firmly until it clicks into place **(fig. 5)**.

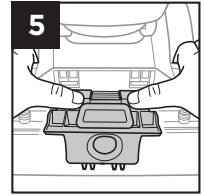
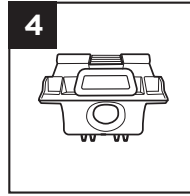
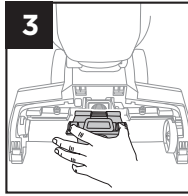
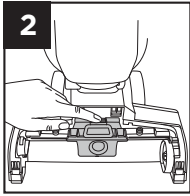
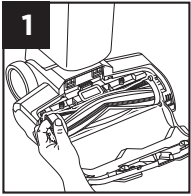

INDICATOR LIGHTS

LED Warnings

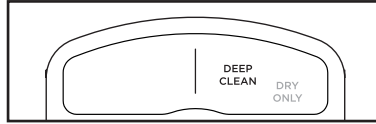

Brushroll Jam



Indicator: 2 steady red lights.

Solution: Remove the nozzle cover, then lift the tabs to open the brushroll cover. Remove the brushroll by pulling on the side tab. Clear all debris, then reinstall both covers.

Valve Error



Indicator: Top light blinking red, bottom light blinking blue.

Solution: Turn the power off, then clear any clogs. See Checking For Debris section for more on clearing clogs. Turn power back on to reset. Note: This valve error will trigger if you move the nozzle forward only or backward only for an extended period. To avoid this error, use shorter back-and-forth strokes when cleaning.

Dirty Water Tank Full



Indicator: Two blinking blue lights.

Solution: Remove the dirty water tank. Pour out liquid and clear debris from hair cage.

Door Open



Indicator: Two blinking red lights.

Solution: Remove the nozzle cover and open the brushroll cover, then close and reinstall, making sure both covers are closed completely.

TROUBLESHOOTING

Purple indicator lights: High temperature alarm. Unit shut down due to overheating. Unplug and allow to cool for 10 minutes.

Poor suction: Make sure all parts are connected securely and the hose clicks twice when attaching it to the back of the unit. See Checking For Debris section above for more information. If issue is not resolved, remove parts and reinstall them to make sure they are fully inserted.

Floor nozzle not dispensing solution: Be sure the solution tank is full. Make sure unit is fully reclined and in Deep Clean Mode.

The Dirty Water Tank Full indicator lights are on, but the tank is not full: See Checking For Debris section for more information. The hair cage in the dirty water tank may be full. Remove the dirty water tank, pour out liquid, and clear hair and debris from the cage.

Hair clumps left behind: To pick up clumps, move the unit forward slowly over remaining hair.

Oversaturated carpets: Passing over cleaned areas in Dry Only Mode will help reduce dry times. Dry times will vary based on cleaning speed, carpet type, and humidity. See Deep Cleaning With Carpetxpert section for cleaning instructions.

Note: To buy cleaning solution, accessories, or replacement parts, visit sharkclean.co.uk.

When a consumer buys a product in the UK, they get the benefit of legal rights relating to the quality of the product (your "legal rights"). You can enforce your legal rights against your retailer, including Shark if you bought your Shark appliance from sharkclean.co.uk. However, at Shark we are so confident about the quality of our products that we give the owner an additional, free parts and labour manufacturer's guarantee of up to 5 years. A household appliance like a Shark floorcare appliance constitutes a sizeable investment. Your new machine needs to work properly for as long as possible. The guarantee it comes with is an important consideration - and reflects how much confidence the manufacturer has in its product and manufacturing quality. The manufacturer's guarantee does not affect your legal rights.

How long are new Shark machines guaranteed for?

Our manufacturer's guarantee lasts for one year from the date of purchase as standard, or for five years if you register your purchase with us within 28 days. There is information on how to register below.

How do I register my Shark guarantee?

If you have purchased your Shark appliance directly from sharkclean.co.uk your guarantee is registered automatically. If you bought it from anywhere else, you can register your guarantee online within 28 days of purchase.

- To register online, please visit www.sharkclean.co.uk/register-guarantee or scan the QR code in your instruction manual.
- Keep a note of the date you purchased the machine.

IMPORTANT:

- Keep your receipt if you bought your Shark floorcare appliance from anywhere except sharkclean.co.uk. You will need it to claim under your guarantee.
- The free Shark guarantee only applies in the UK and is only valid from date of purchase.

What are the benefits of registering my free Shark guarantee?

When you register your guarantee, you will get an extra four years of cover. We'll also have your details to hand if we ever need to get in touch. If you further agree to receive communications from us, you can also receive tips and advice on how to get the best out of your Shark floorcare appliance and hear the latest news about new Shark technology and launches.

What is covered by the free Shark guarantee?

Repair or replacement (at Shark's option) of your Shark machine, including all parts and labour.

What is not covered by the free Shark guarantee?

- Normal wear and tear.
- Accidental damage or faults caused by negligent use or care, misuse, neglect, careless operation, or handling of the Shark appliance which is not in accordance with the Shark Operating Manual supplied with your machine.
- Damage caused by use of the Shark appliance for anything other than normal domestic household purposes.
- Damage caused by use of parts not assembled or installed in accordance with the operating instructions.
- Damage caused by use of parts and accessories which are not Shark Genuine Components
- Faulty installation (except where installed by Shark).
- Repairs or alterations carried out by parties other than Shark or its agents.

How can I claim under the free Shark guarantee?

Contact our customer service helpline on **0800 862 0453**. For service hours please visit our website under 'Contact Us'. It's free to call, and you'll be put straight through to a Shark representative. You'll also find online support at <https://support.sharkclean.co.uk>. The Shark representative will go through some troubleshooting with you, and if we conclude that the item has failed, we will send you a replacement part or a returns label to send the defective item back to us free of charge. When you have delivered the defective product to us, we will send you a replacement.

Please remember that the item will need to be boxed when you return it to us, which can be any suitable box; it does not have to be the original packaging.

Where can I buy genuine Shark spares and accessories?

Shark spares and accessories are developed by the same engineers who developed your Shark floorcare appliance. You'll find a full range of Shark spares, replacement parts and accessories for all Shark machines at www.sharkclean.co.uk. Please remember that damage caused by the use of non-Shark spares may not be covered under your guarantee.



PLEASE READ CAREFULLY AND KEEP FOR FUTURE REFERENCE.

This Instruction Booklet is designed to help you get a complete understanding of your new Shark® carpet cleaner.

SharkNinja Europe Limited,
1st/2nd Floor Building 3150,
Thorpe Park, Century Way,
Leeds,
England,
LS15 8ZB

SharkNinja Germany GmbH,
Rotfeder-Ring 9,
60327 Frankfurt am Main,
Germany
www.sharkclean.eu

www.sharkclean.co.uk

Illustrations may differ from actual product. We are constantly striving to improve our products; therefore the specifications contained herein are subject to change without notice.

© 2024 SharkNinja Operating LLC.

SHARK and CARPETXPRT are registered trademarks in the United Kingdom of SharkNinja Operating LLC.