

REVEL®

C263, C283, C363XC, C383XC

**In-Ceiling Architectural
Loudspeaker
Instruction Manual**



DOCUMENTATION CONVENTIONS

This document contains general safety, installation and operation instructions for the Revel® C283, C263, C383XC, and C363XC in-ceiling loudspeakers. It is important to read this document before attempting to use this product. Pay particular attention to:

WARNING: Calls attention to a procedure, practice, condition or the like that, if not correctly performed or adhered to, could result in injury or death.

CAUTION: Calls attention to a procedure, practice, condition or the like that, if not correctly performed or adhered to, could result in damage to or destruction of part of or the entire product.

Note: Calls attention to information that aids in the installation or operation of the product.

ABOUT REVEL® IN-CEILING SPEAKERS

Since the first Revel® speakers in 1996, Revel products have stood at the forefront of loudspeaker design and performance. Revel in-ceiling loudspeakers draw upon the same research, resources and unique perspective that put all Revel loudspeakers in a class by themselves. Revel in-ceiling loudspeakers provide unparalleled value and are known for their standard-setting low sonic coloration and their freedom from distortion over an extraordinarily wide dynamic range.

IN-CEILING LOUDSPEAKER HIGHLIGHTS

- Long-throw woofers with rubber surrounds provide high output with low distortion.
- A 1-inch (25mm) metal-dome tweeter with an integrated waveguide provides optimized response both on and off axis.
- A high-order crossover network delivers accurate timbre reproduction.
- Extreme Climate (XC) models feature a durable, low-profile design suitable for damp, wet, or high humidity installations.

PRODUCT REGISTRATION

Please take a moment to register your product on our Web site at www.revelspeakers.com. You'll enable us to keep you posted on our latest advancements and help us to understand our customers and build products that meet their needs and expectations.

BOX CONTENTS

Your Revel in-ceiling loudspeaker box should contain the following items:

- 1 x Revel in-ceiling loudspeaker
- 1 x grille
- 1 x extra scrim cloth for grille
- 1 x mounting template
- 1 x instruction manual

UNPACKING THE SPEAKER

Carefully unpack the speaker. If you suspect damage from transit, report it immediately to your dealer and/or delivery service. Keep the shipping carton and packing materials for future use.

INSTALLATION CONSIDERATIONS

Your new Revel loudspeakers have been engineered to provide extremely accurate performance. However, any speaker's ultimate performance will be affected by the speaker's placement in the listening room and the acoustics of the room. Not all listening spaces can accommodate the ideal conditions of these two factors. Therefore, careful attention to the placement of your Revel in-ceiling loudspeakers will have a significant impact on the general performance of the loudspeakers.

EXTREME CLIMATE MODELS

The C363XC and C383XC models provide a weatherized solution that is suitable for damp, wet, or high humidity installations including marine applications. Their shallow mounting depth allows maximum placement and installation flexibility for locations that require a durable loudspeaker without sacrificing high-performance sound quality.

LOUDSPEAKER PLACEMENT FOR DISTRIBUTED SOUND

- Since distributed sound is general sound throughout an area, place the loudspeakers as uniformly as possible for even sound coverage throughout the area.
- Place the left and right loudspeakers roughly the same distance from the primary listener locations.
- To avoid “hot spots” where the sound is too loud, plan to use more loudspeakers, with each set to play at a lower volume.

LOUDSPEAKER PLACEMENT FOR TWO-CHANNEL STEREO

Place the left and right loudspeakers the same distance from the primary listening area (or as close to the same distance as possible). The distance from each speaker to its nearest side wall should also be the as close to the same distance as possible.

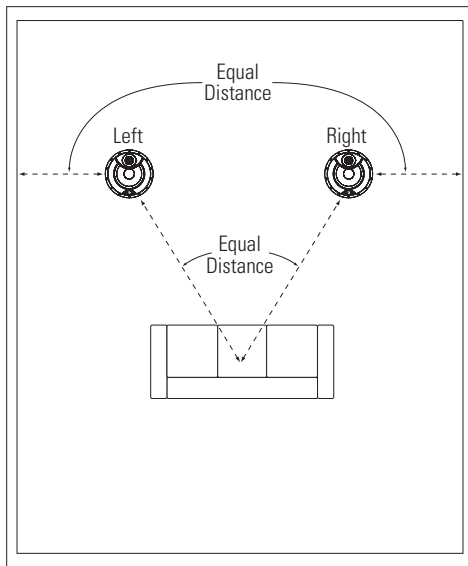

Ideally, the distance between the left and right loudspeakers should be slightly less than their distance from the primary listening area.

LOUDSPEAKER PLACEMENT FOR HOME THEATER

- The front left, center and front right loudspeakers should be centered relative to the video display.
- The front left, center and front right loudspeakers should be closer to the video display than to the main listening area. For example, if the video display is 10 ft (3m) from the main listening area, the loudspeakers should be 6 ft (1.8m) or further from the main listening area.
- The front left and front right loudspeakers should be relatively close to the sides of the video display. For example, front left and front right loudspeakers used with a 50-in (1.2m) video display should generally not be more than 80 in (2m) apart.
- The center loudspeaker should be aligned with the center of the video display.
- The surround-channel loudspeakers should be as far from the main listening area as possible but at least 2 feet (0.6m) from side and rear walls.

5.1-Channel Speaker Placement

- In a 5.1-channel system, the surround left and surround right loudspeakers should be located directly to the sides of, or up to 10 degrees behind, the main listening area.

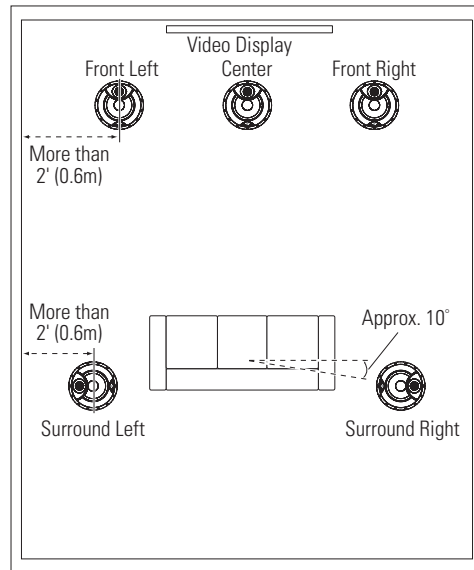

7.1-Channel Speaker Placement

- In a 7.1-channel system, the surround left and surround right loudspeakers should be located directly to the sides of, or up to 10 degrees behind, the main listening area.
- In a 7.1-channel system, the surround back left and surround back right loudspeakers should be equidistant from the primary listening area and generally as far from it as possible but at least 2 ft (0.6m) from the side and rear walls.

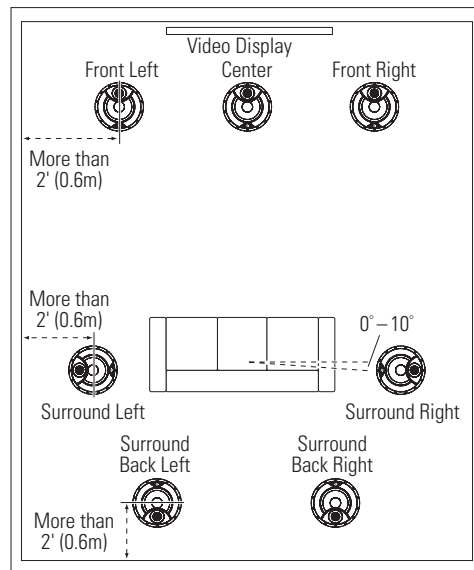

INSTALLATION INSTRUCTIONS

CAUTION: Do not use the tweeter-mounting baffle as a handle to move, carry or position the speaker. Doing so can damage the baffle. Such damage is not covered by the speaker's warranty.



Revel architectural speakers are extremely easy to install. However, if you are unable to understand and follow the instructions in this manual clearly and fully, or if you are unsure of your ability to install these loudspeakers properly, please contact your dealer or a qualified installer.

WARNING: HARMAN International assumes no responsibility for improper installation of hardware or for any personal injuries or product damages resulting from improper installation or a fallen loudspeaker.

CONNECTING TO THE AMPLIFIER

CAUTION: REMOVE POWER

You must connect the speaker wires before the speaker is fully installed. To protect the audio system and yourself from damage or injury through accidental electrical shorting and surges during installation, turn all audio system power OFF before beginning the speaker installation.

Speaker Wire

Use high-quality speaker wire to obtain the best performance from your Revel in-ceiling speakers.

- For wire lengths of less than 50 ft (15m), use at least 16-gauge speaker wire.
- For wire lengths between 50 ft and 100 ft (15m – 30m), use at least 12-gauge speaker wire.
- For wire lengths of greater than 100 ft (30m), use at least 10-gauge speaker wire.

Note: All speaker wires must comply with all local building and safety codes for use in in-ceiling applications.

Making Connections

Connect each channel's positive (+) terminal on the back of the amplifier or receiver to the positive (red) terminal on the corresponding speaker; connect each channel's negative (–) terminal on the back of the amplifier or receiver to the negative (black) terminal on the corresponding speaker. Do not reverse polarities (that is, do not connect + to –, or – to +) when making connections. Doing so will cause poor imaging and diminished bass response.

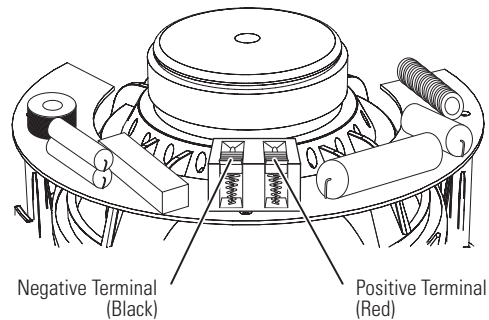

Press down on the terminal tab to open the hole; insert the bare end of the wire into the hole; and release the tab to secure the wire. NOTE: C383XC and C363XC models have post-type terminals. Press down on the post to open the hole; insert the bare end of the wire into the hole and release the post to secure the wire.

CAUTION: To avoid short circuits that may damage your equipment, be certain that positive and negative wire strands do not touch each other and do not touch metal parts such as the speaker frame.

MOUNTING THE SPEAKERS

For New Construction

If you wish to pre-install a rough-in frame for the speakers before the drywall is installed in new construction, you will need to purchase the correct rough-in frame kit for your loudspeaker model from your authorized Revel dealer. Detailed mounting instructions are supplied with the rough-in kit. After the drywall is installed, follow the installation instructions in *For Existing Construction*, below.

For Existing Construction

Note: The installation procedure is the same for all models covered by this manual.

1. Ensure that the drywall, plywood or other ceiling material is 1/2" – 2" (13mm – 51mm) thick and capable of withstanding the weight of the speaker being installed.

Make sure to allow at least 3/4" (19mm) between the edge of the supplied installation template and any rafters or other obstructions behind the wall, so the speaker's locking mechanism will have room to engage fully. Perform an obstruction survey to be sure that there are no studs, lengths of conduit, pipes, heating ducts or air returns in the ceiling cavity that will interfere with the speaker.

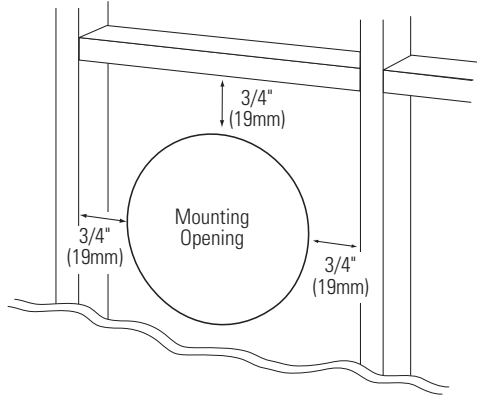

2. Determine the correct speaker location and use the template included with the speaker to mark the ceiling material.

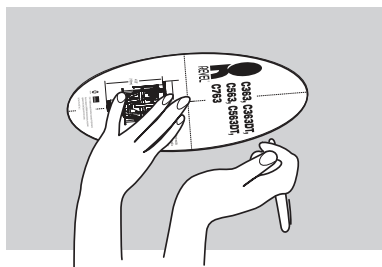

3. Cut the ceiling drywall along the mark you made in Step 2 to create the mounting opening.

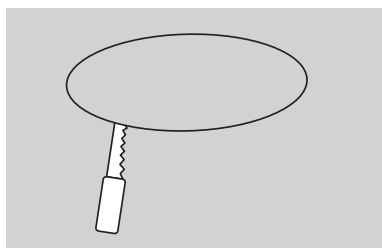

4. Connect the speaker to the amplifier as explained in *Connecting to the Amplifier*, on page 4.

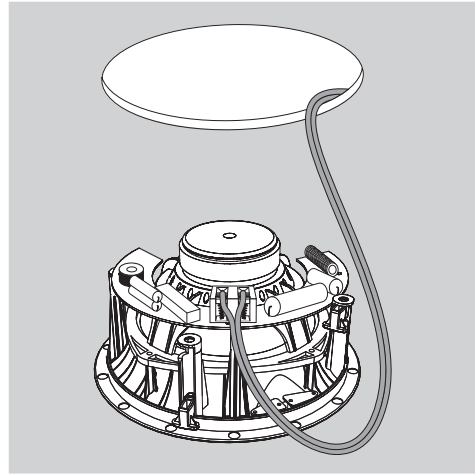

5. Attach the speaker's seismic tab to a support line, as per local safety regulations.

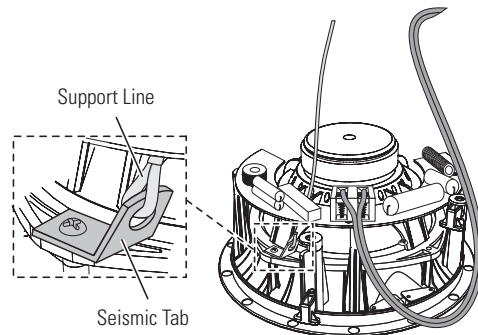

6. Make sure all four speaker clamps are in their "ready-to-mount" position.

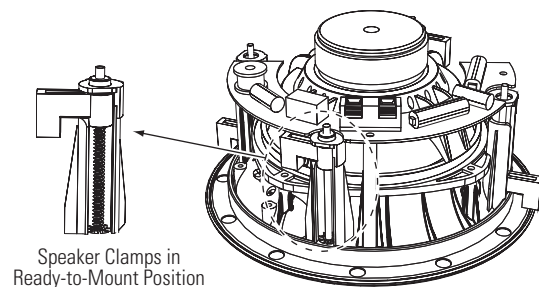

7. Insert the speaker straight into the mounting opening. Tighten the speaker-clamp screws on the front of the speaker baffle. The speaker clamps will automatically rotate into position and begin clamping the speaker.

- When you notice resistance on the screws, the speaker has been clamped successfully.

IMPORTANT: Always use low-torque settings. NEVER over-tighten the clamp screws

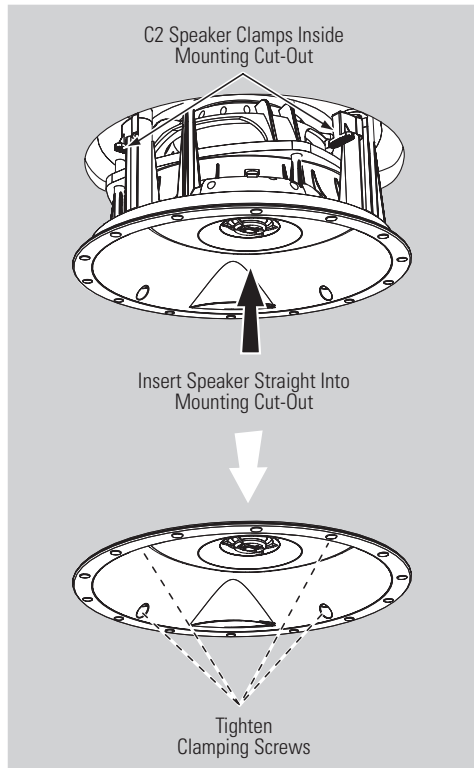

8. Attach the supplied grille. Powerful magnets in the speaker frame will securely hold the grille in place.

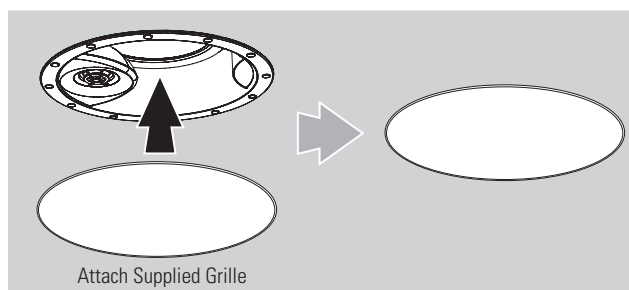

Painting the Grille

Revel architectural loudspeaker grilles can be painted to match any décor. If you wish to change the grille's color, its satin finish will function as a primer coat. For the best results follow this procedure:

1. Gently remove the scrim cloth from the back side of the grille before painting.
2. Use a high-quality spray paint and apply a thin coat of color. Ensure that the grille perforations remain free of paint. Filling them with paint will diminish the speaker's sound quality. If any perforations are plugged, use compressed air to blow the paint out of the perforations.

Note: If you find any grille perforations that are plugged with paint after the paint has dried, carefully use a straight pin or sewing needle to remove the paint.

3. We have included replacement scrim cloths. After the paint has dried, apply a light coat of spray adhesive to the inside of the perforated grille and attach a new scrim cloth. **IMPORTANT:** Never spray adhesive on the cloth. The square scrim cloth has pre-attached foam pads that help prevent the grille from vibrating against the ceiling.

NOTE: Square grilles are available for Revel C263, C283, C363XC and C383XC speakers. Contact your authorized Revel dealer for details.

EXCESSIVE OUTPUT LEVELS

Your Revel loudspeakers feature custom-designed transducers and high-quality network components featuring high-order filters with steep cutoffs that reduce the potential of damage to individual speaker drivers and help the loudspeakers maintain their performance even under extreme operating conditions. However, all loudspeakers have limits when it comes to continuous playback. To extend these limits, avoid playback at volume levels that result in distorted or strained sound.

OBTAINING SERVICE

To obtain service, contact an authorized Revel dealer. Refer to *Limited Warranty*, on page 8 for more information.

DIMENSIONS

	Mounting Opening Diameter	Mounting Depth	Overall Dimensions (w/grille)
C283	9-5/8" (244mm)	5-1/8" (130mm)	10-23/32" (272mm) Dia. x 5-5/16" (135mm) Deep
C263	8" (203mm)	4-23/32" (120mm)	9-3/32" (231mm) Dia x 4-15/16" (125mm) Deep
C383XC	9-5/8" (244mm)	2-3/4" (70mm)	10-23/32" (272mm) Dia. x 2-31/32" (75mm) Deep
C363XC	8" (203mm)	2-11/16" (69mm)	9-3/32" (231mm) Dia. x 2-15/16" (74mm) Deep

Dimensions are subject to change without notice.

For complete performance specifications, please go to the Revel Web site: www.revelspeakers.com.



LIMITED WARRANTY

Revel speakers are warranted against defects. The duration of a speaker's warranty depends on the laws in the country in which it was purchased. Your local Revel retailer can help you determine the length of your warranty.

HARMAN

HARMAN International Industries, Incorporated
8500 Balboa Blvd., Northridge, CA 91329

© 2012 HARMAN International Industries, Incorporated. All rights reserved.

Revel and the Revel logo are trademarks of HARMAN International Industries, Incorporated, registered in the United States and/or other countries.

Features, specifications and appearance are subject to change without notice.

For questions, assistance or additional information concerning any of our products, call us at: (516) 594-0300 or (888) 691-4171.

For technical support, submit your detailed inquiry to: csupport@harman.com.

Part No. REVP4908 Rev. B



www.revelspeakers.com