

SCHWINN™

590R



Manuals in additional languages:
<http://www.schwinnfitness.com>

ASSEMBLY MANUAL / OWNER'S MANUAL

TABLE OF CONTENTS

Important Safety Instructions	3	Operations	25
Safety Warning Labels / Serial Number	5	Adjustments	25
Specifications	6	Power Up / Idle Mode	25
Before Assembly	6	Manual (Quick Start) Program	26
Parts	7	Profile Programs	26
Hardware	8	Modify Display of Workout Values	27
Tools	8	Pausing or Stopping	27
Assembly	9	Summary Mode	28
Moving the Machine	18	Console Setup Mode	28
Leveling the Machine	18	Maintenance	30
Features	19	Maintenance Parts	31
Console Features	20	Troubleshooting	33
Bluetooth® Heart Rate Monitor	23		

To validate warranty support, keep the original proof of purchase and record the following information:

Serial Number _____

Date of Purchase _____

If purchased in US/Canada: To register your product warranty, go to: www.SchwinnFitness.com/register

Or call 1 (800) 605–3369.

If purchased outside US/Canada: To register your product warranty, contact your local distributor.

For details regarding product warranty or if you have questions or problems with your product, please contact your local distributor. To find your local distributor, go to: global.schwinnfitness.com

Nautilus, Inc., 5415 Centerpoint Parkway, Groveport, OH 43125 USA, www.NautilusInc.com - Customer Service: North America (800) 605-3369, csnls@nautilus.com | Nautilus (Shanghai) Fitness Equipments Co, Ltd, Room 1701 &1702, 1018 Changning Road, Changning District, Shanghai, China 200042, www.nautilus.cn - 86 21 6115 9668 | outside U.S. www.nautilusinternational.com | © 2021 Nautilus, Inc. | Schwinn, the Schwinn Quality logo, Schwinn 590R, JRNY, Bowflex and Nautilus are trademarks owned by or licensed to Nautilus, Inc., which are registered or otherwise protected by common law in the United States and other countries. Other trademarks are the property of their respective owners. The Bluetooth® word mark and logos are registered trademarks owned by Bluetooth SIG, Inc., and any use of such marks by Nautilus, Inc. is under license.

ORIGINAL MANUAL - ENGLISH VERSION ONLY

IMPORTANT SAFETY INSTRUCTIONS

⚠ This icon means a potentially hazardous situation which, if not avoided, could result in death or serious injury.

Obey the following warnings:

⚠ Read and understand all warnings on this machine.

Carefully read and understand the Assembly instructions.

- Keep bystanders and children away from the product you are assembling at all times.
- Do not connect power supply to the machine until instructed to do so.
- Do not assemble this machine outdoors or in a wet or moist location.
- Make sure assembly is done in an appropriate work space away from foot traffic and exposure to bystanders.
- Some components of the machine can be heavy or awkward. Use a second person when doing the assembly steps involving these parts. Do not do steps that involve heavy lifting or awkward movements on your own.
- Set up this machine on a solid, level, horizontal surface.
- Do not try to change the design or functionality of this machine. This could compromise the safety of this machine and will void the warranty.
- If replacement parts are necessary, use only genuine Nautilus replacement parts and hardware. Failure to use genuine replacement parts can cause a risk to users, keep the machine from operating correctly and void the warranty.
- Do not use until the machine has been fully assembled and inspected for correct performance in accordance with the Manual.
- Read and understand the complete Manual supplied with this machine before first use. Keep the Manual for future reference.
- Do all assembly steps in the sequence given. Incorrect assembly can lead to injury or incorrect function.
- **SAVE THESE INSTRUCTIONS.**

Before using this equipment, obey the following warnings:

⚠ Read and understand the complete Manual. Keep the Manual for future reference.

Read and understand all warnings on this machine. If at any time the Warning labels become loose, unreadable or dislodged, replace the labels. If purchased in US/Canada, contact Customer Service for replacement labels. If purchased outside US/Canada, contact your local distributor for them.

- Children must not be let on or near to this machine. Moving parts and other features of the machine can be dangerous to children.
- Not intended for use by anyone under 14 years of age. Individuals between 14 and 17 years of age must be supervised when using this machine.
- Consult a physician before you start an exercise program. Stop exercising if you feel pain or tightness in your chest, become short of breath, or feel faint. Contact your doctor before you use the machine again. Use the values calculated or measured by the machine's computer for reference purposes only.
- Before each use, examine this machine for loose parts or signs of wear. Do not use if found in this condition. Monitor the Seat, Pedals, and Crank Arms closely. If purchased in US/Canada, contact Customer Service for repair information. If purchased outside US/Canada, contact your local distributor for repair information.
- Maximum user weight limit: 150 kg. (330 lb). Do not use if you are over this weight.
- The machine is intended for Home/Consumer or Studio/Institutional use. When the machine is placed into a Studio/Institutional environment, usage should be limited to less than 3 hours per day, and it should only be used in areas where access and control of the machine are managed and supervised by approved staff. The degree of management depends among other things on the specific setting in which the machine is placed, security of that environment, and familiarity of the users with the equipment. Because others will have used the machine previously, make sure the seat, pedals and handlebars are correctly adjusted, tightened and secured.

- Do not wear loose clothing or jewelry. This machine contains moving parts. Do not put fingers or other objects into moving parts of the exercise equipment.
- Set up and operate this machine on a solid, level, horizontal surface.
- Make the Pedals stable before you step on them. Use caution when you step on and off the machine.
- Disconnect all power before servicing this machine.
- Do not operate this machine outdoors or in moist or wet locations. Keep the foot pedals clean and dry.
- Keep at least 0.6 m (24 in) along the side used to access the machine and to the rear of the machine clear. This is the recommended safe distance for access, passage and emergency dismounts from the machine. Keep third parties out of this space when machine is in use.
- Do not over exert yourself during exercise. Operate the machine in the manner described in this manual.
- Correctly adjust and safely engage all Positional Adjustment Devices. Make sure that the Adjustment Devices do not hit the user.
- Exercise on this machine requires coordination and balance. Be sure to anticipate that changes in speed and resistance level can occur during workouts, and be attentive in order to avoid loss of balance and possible injury.
- A machine should never be left unattended when plugged in. Unplug from outlet when not in use, and before putting on or taking off parts.
- Do not back, or reverse, pedal. Doing so may loosen the Pedals, which could result in damage to the machine and/or injury to the user. Never operate this machine with loose Pedals.
- This appliance is not intended for use by persons (including children) with reduced physical, sensory or mental capabilities, or lack of experience and knowledge, unless they have been given supervision or instruction concerning use of the appliance by a person responsible for their safety.
- Children should be supervised to ensure that they do not play with the appliance.
- **SAVE THESE INSTRUCTIONS.**

SAFETY WARNING LABELS AND SERIAL NUMBER

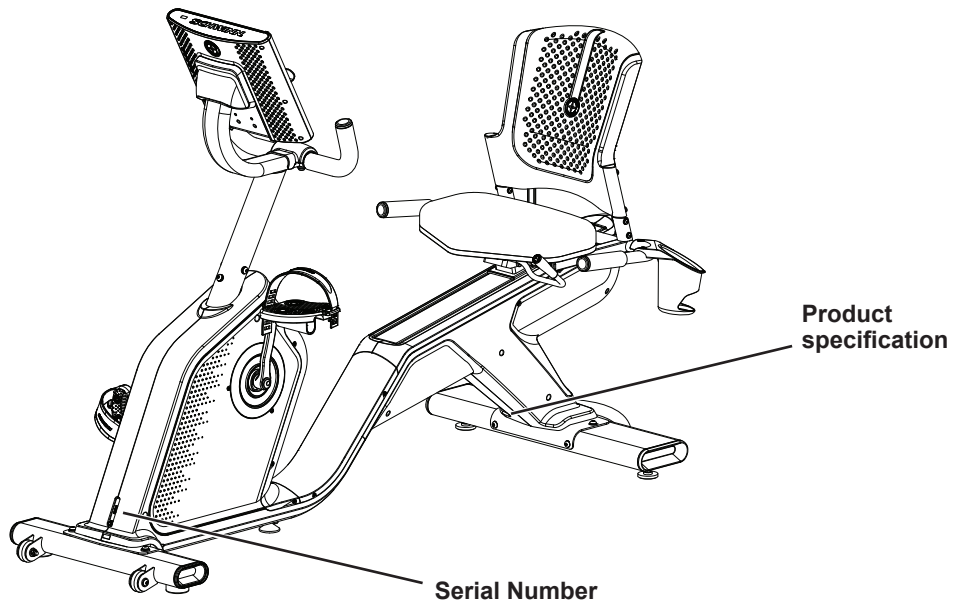

This product complies with the European Radio Equipment Directive 2014/53/EU.

SPECIFICATIONS

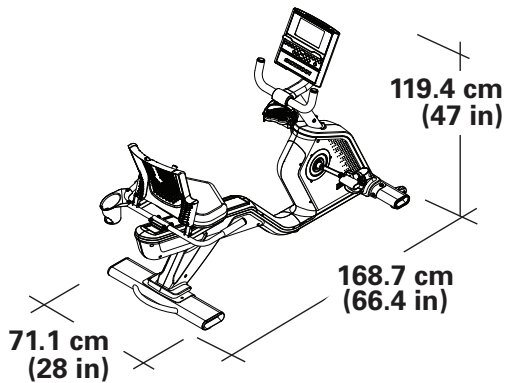

Maximum User Weight: 150 kg (330 lb)
Total Surface Area (footprint) of equipment: 11,994.6 cm² (1859.2 in²)
Machine Weight: 48.8 kg (107.6 lb)

Power Requirements (AC Adapter):

Input Voltage: 100 - 240V AC, 50/60Hz, 0.5A
Output Voltage: 12V DC, 3A



DO NOT dispose of this product as refuse. This product is to be recycled. For proper disposal of this product, please follow the prescribed methods at an approved waste center.

Before Assembly

Select the area where you are going to set up and operate your machine. For safe operation, the location must be on a hard, level surface. We recommend an assembly area of 2.9 m x 1.9 m (114 in x 76 in). Estimated time to assemble the machine is 60 - 90 minutes. Allow a workout area of a minimum 2.3 m x 1.3 m (90 in x 52 in).

NOTICE: Inspect the machine for damaged parts due to delivery. If damage is found, contact Customer Service (if inside US/Canada) or your local distributor (if outside US/Canada) for assistance.

Basic Assembly Tips

Follow these basic points when you assemble your machine:

- Read and understand the "Important Safety Instructions" before assembly.
- Collect all the pieces necessary for each assembly step.
- Using the recommended wrenches, turn the bolts and nuts to the right (clockwise) to tighten, and the left (counterclockwise) to loosen, unless instructed otherwise.
- When attaching 2 pieces, lightly lift and look through the bolt holes to help insert the bolt through the holes.
- The assembly can require 2 people.

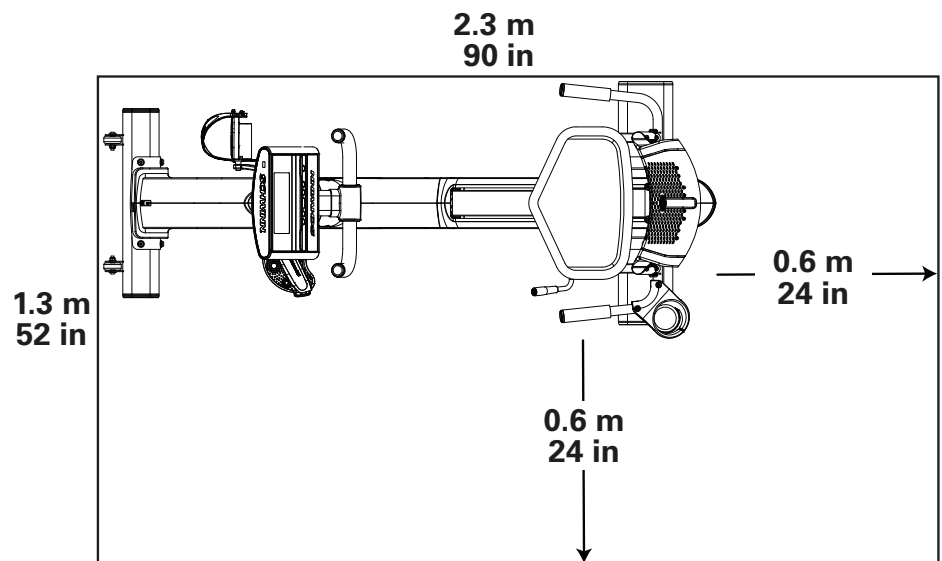

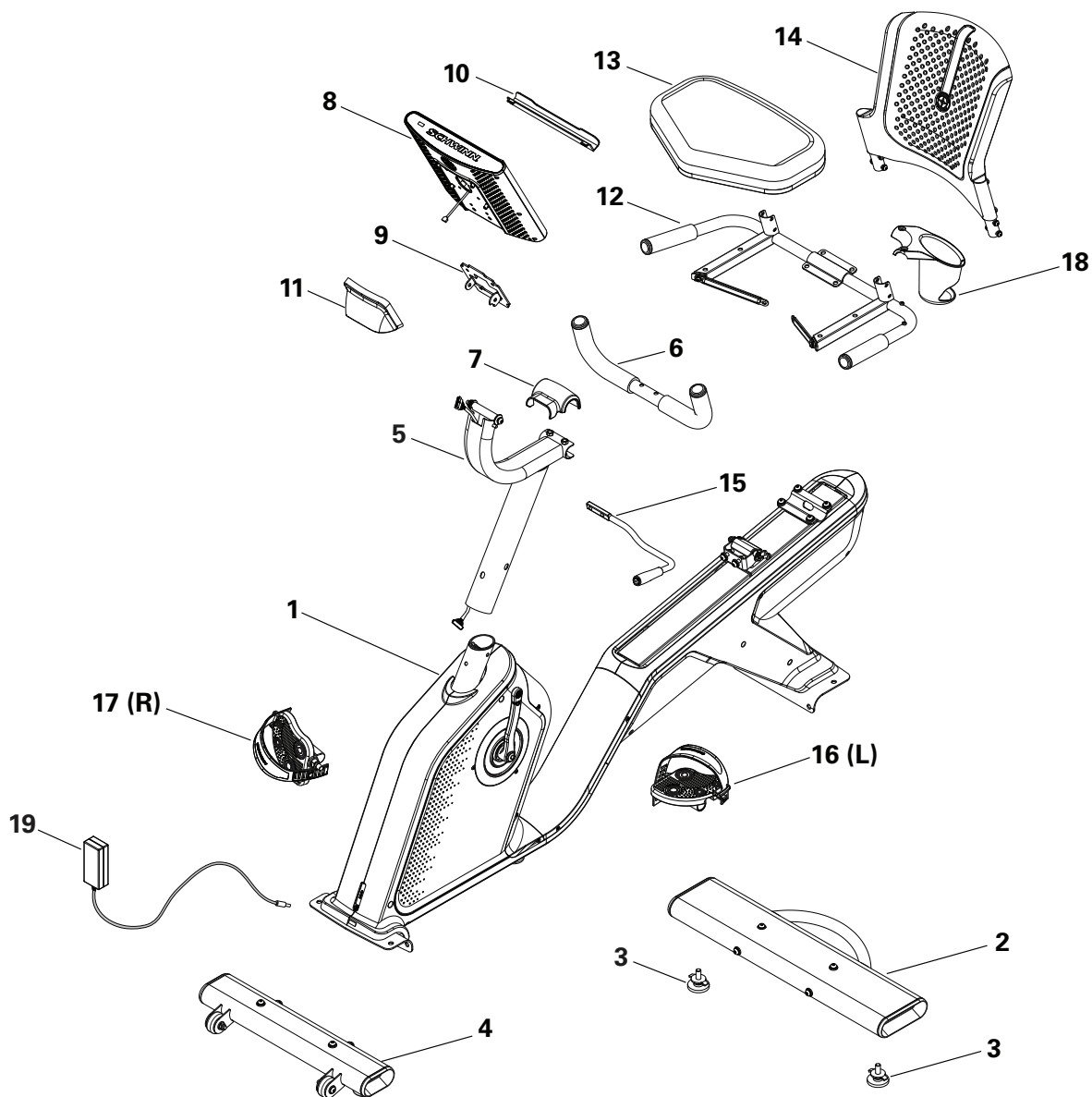

Item	Qty	Description	Item	Qty	Description
1	1	Main Assembly	11	1	Pivot Cover
2	1	Rear Stabilizer	12	1	Seat Frame
3	2	Leveler Feet	13	1	Seat Pad
4	1	Front Stabilizer	14	1	Seat Back
5	1	Console Mast	15	1	Seat Adjustment Handle
6	1	Upright Handlebar	16	1	Left Pedal (L)
7	1	Handlebar Mount Cover	17	1	Right Pedal (R)
8	1	Console	18	1	Cup Holder
9	1	Console Mount Bracket	19	1	AC Adapter
10	1	Media Tray *			

* This item is in bag with Manuals.

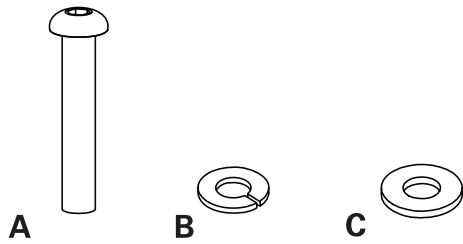

Item	Qty	Description
A	4	Button Head Hex Screw, M8x45
B	4	Spring Washer, M8
C	4	Flat Washer, Narrow, M8

Note: Selected pieces of Hardware have been provided as spares on the Hardware Card. The hardware pieces (*) are for the Console Mast. Be aware that there may be remaining Hardware after the proper assembly of your machine.

Tools

Included



4 mm
6 mm



#2
13 mm
14 mm
15 mm

1. Attach Leveler Feet to Rear Stabilizer, and Stabilizers to Main Assembly

Note: Hardware (*) is pre-installed and not on the Hardware Card. Make sure the center leveler (1a) is not raised too high for stability of the Frame. Hand tighten hardware, then fully tighten.

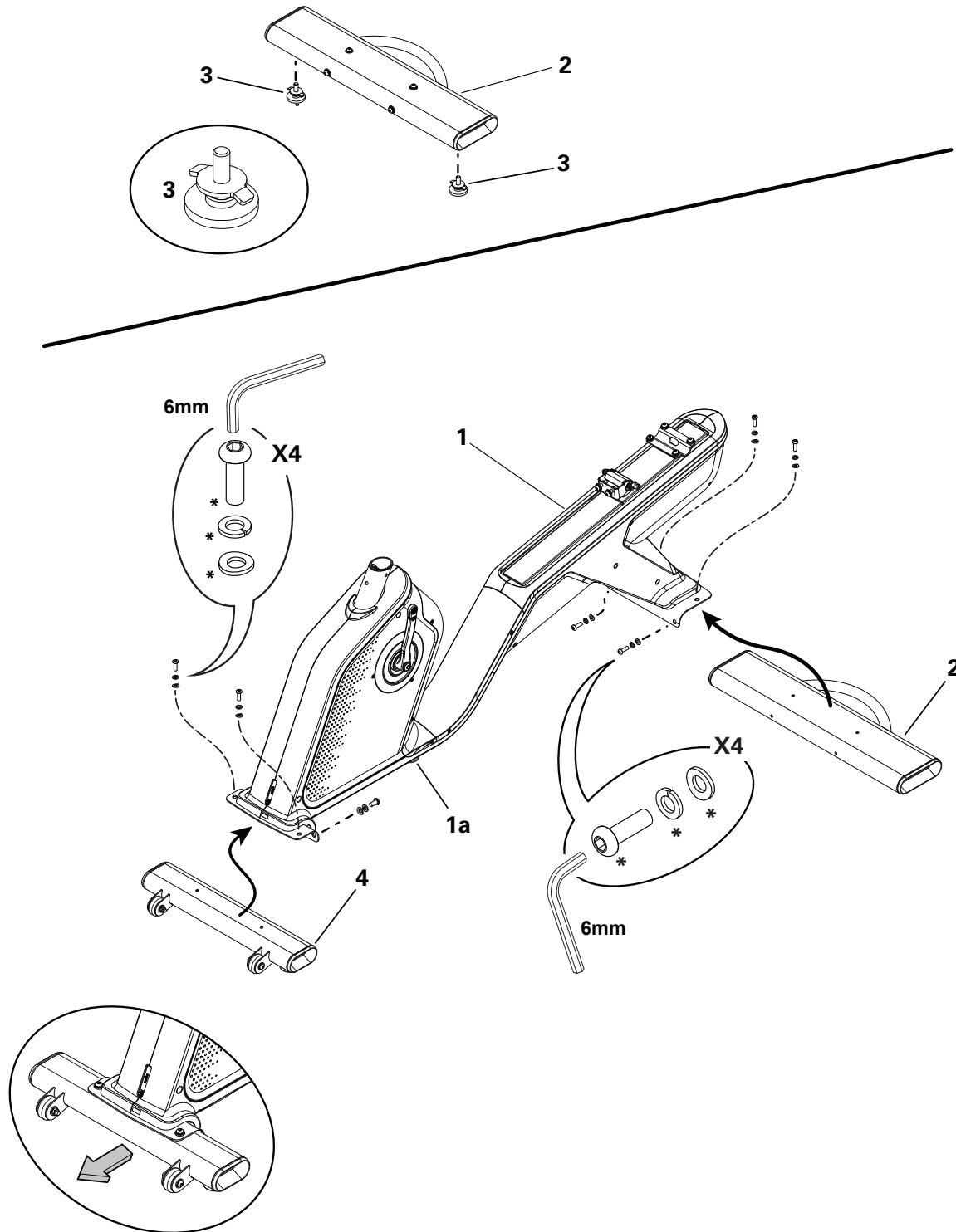

2. Connect the Cables and Attach the Console Mast to Frame Assembly

NOTICE: Remove the pre-installed hardware(*) from the mast mount. The Frame cable connector (1b) is attached to the plastic insert in the mast mount. Leave the plastic insert and Frame cable connector in place and carefully connect the Console Mast cable. Align the clips on the cable connectors and make sure the connectors lock. Do not cut or pinch the cables. Do not let hardware fall into the machine. Align the curved washers so the surface is flush with the Console Mast tube.

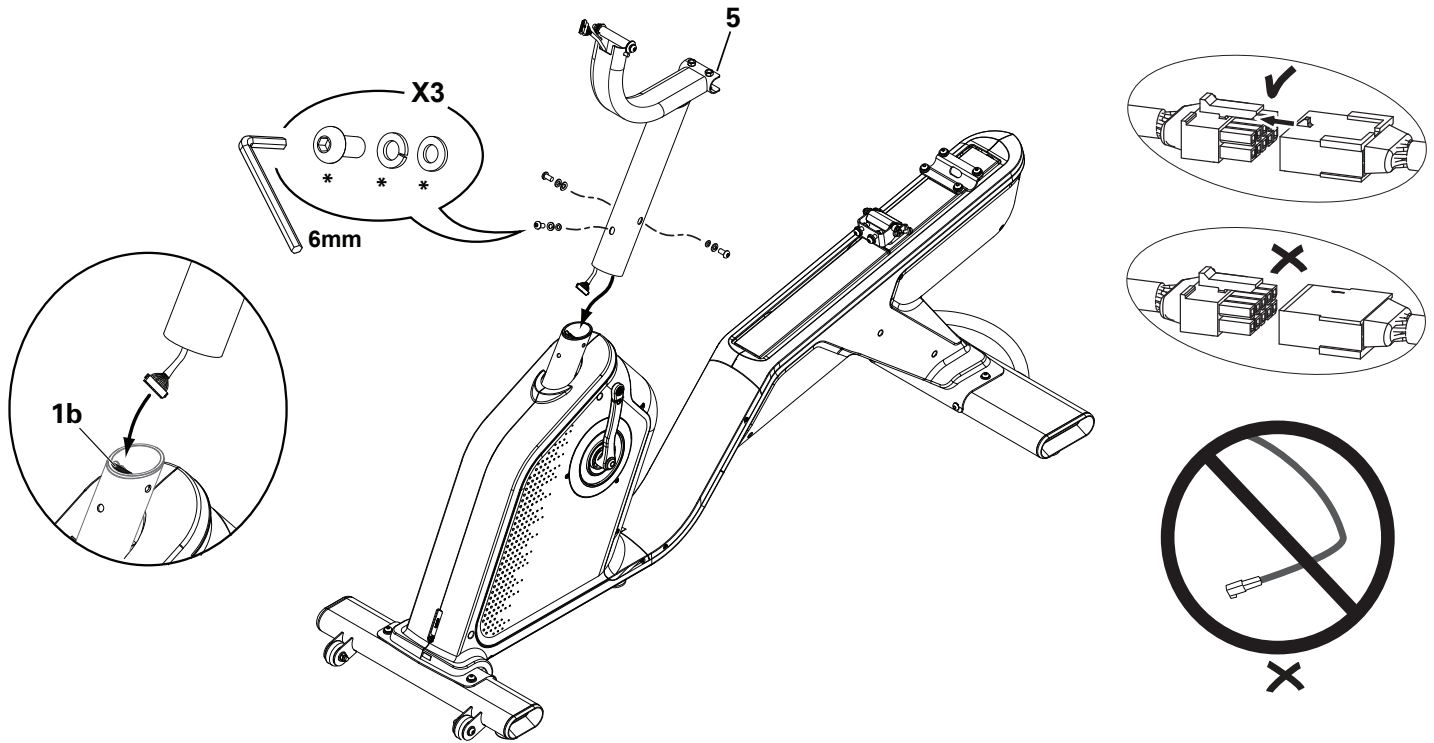

3. Attach Handlebar to the Console Mast

NOTICE: The hardware(*) is pre-installed on the Handlebar. Be sure the Handlebar is attached at the correct angle. Fully tighten hardware. Push the cover (7) into position on the Handlebar mount.

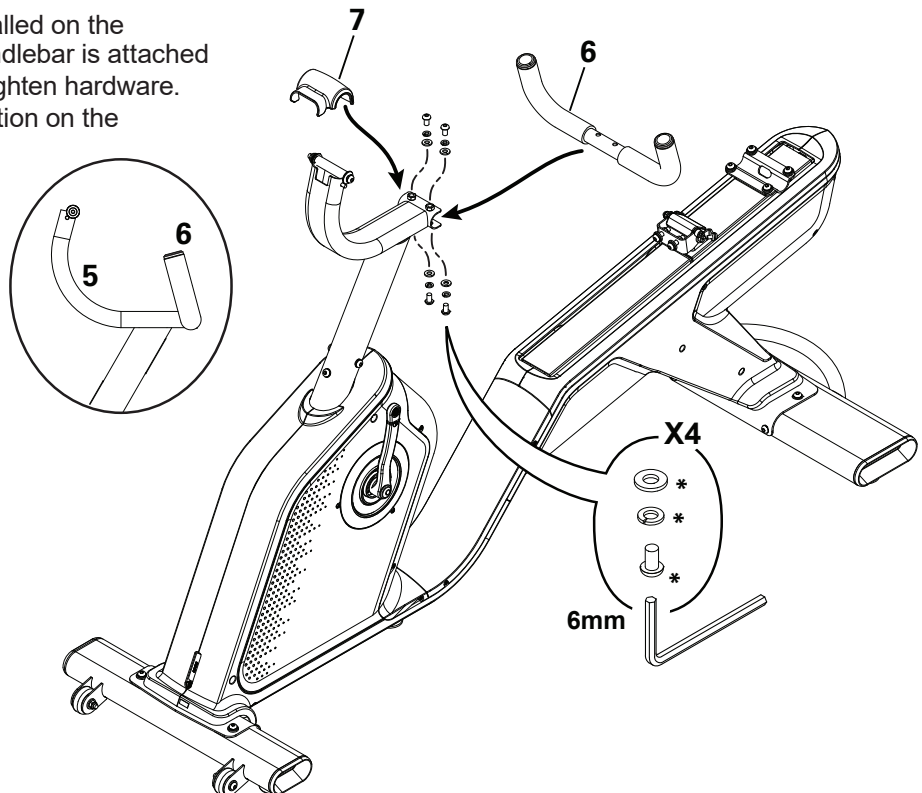

4. Attach Console Mount Bracket to Console Mast

Note: The hardware(*) is pre-installed on the Console Mast.

NOTICE: Do not cut or pinch the cable.

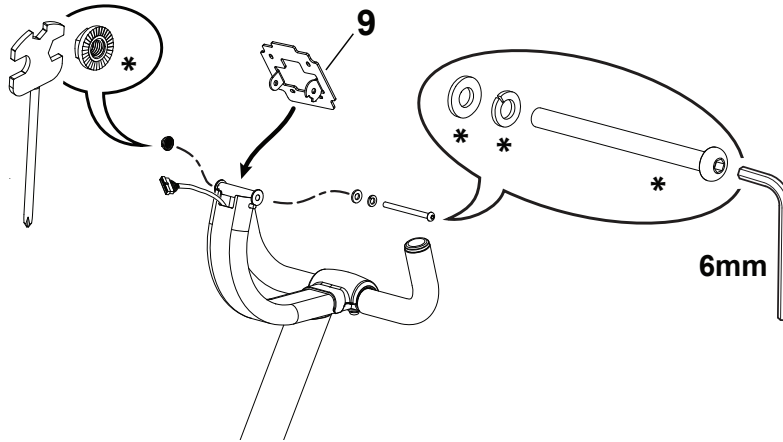

5a. Remove Console Screws

Note: Remove the pre-installed screws (*) from the back of the Console.

NOTICE: Do not let the screws fall inside the Console. Do not cut or pinch the cable.

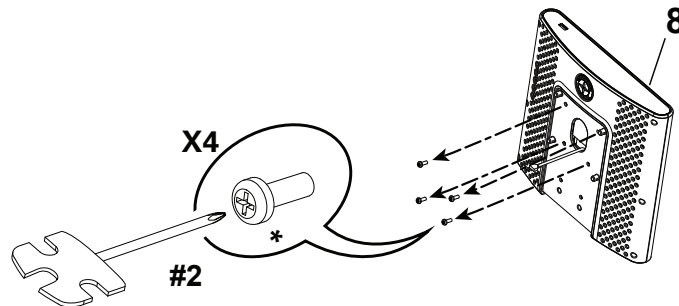

5b. Install the Console Assembly on the Console Mast

NOTICE: This step requires two people. Do not cut or pinch the cables.

Note: Tilt the Console to install the wide tab (9a) at the top of the Console Mount Bracket. Route the Console cable through the bracket. Attach the Console to the Console Mount Bracket before connecting the cables. Start lower screws (*) first, then tighten all screws. Connect the Console cable to the Console Mast cable. Align the clips on the cable connectors and make sure the connectors lock. Push the extra wire down into the Console Mast.

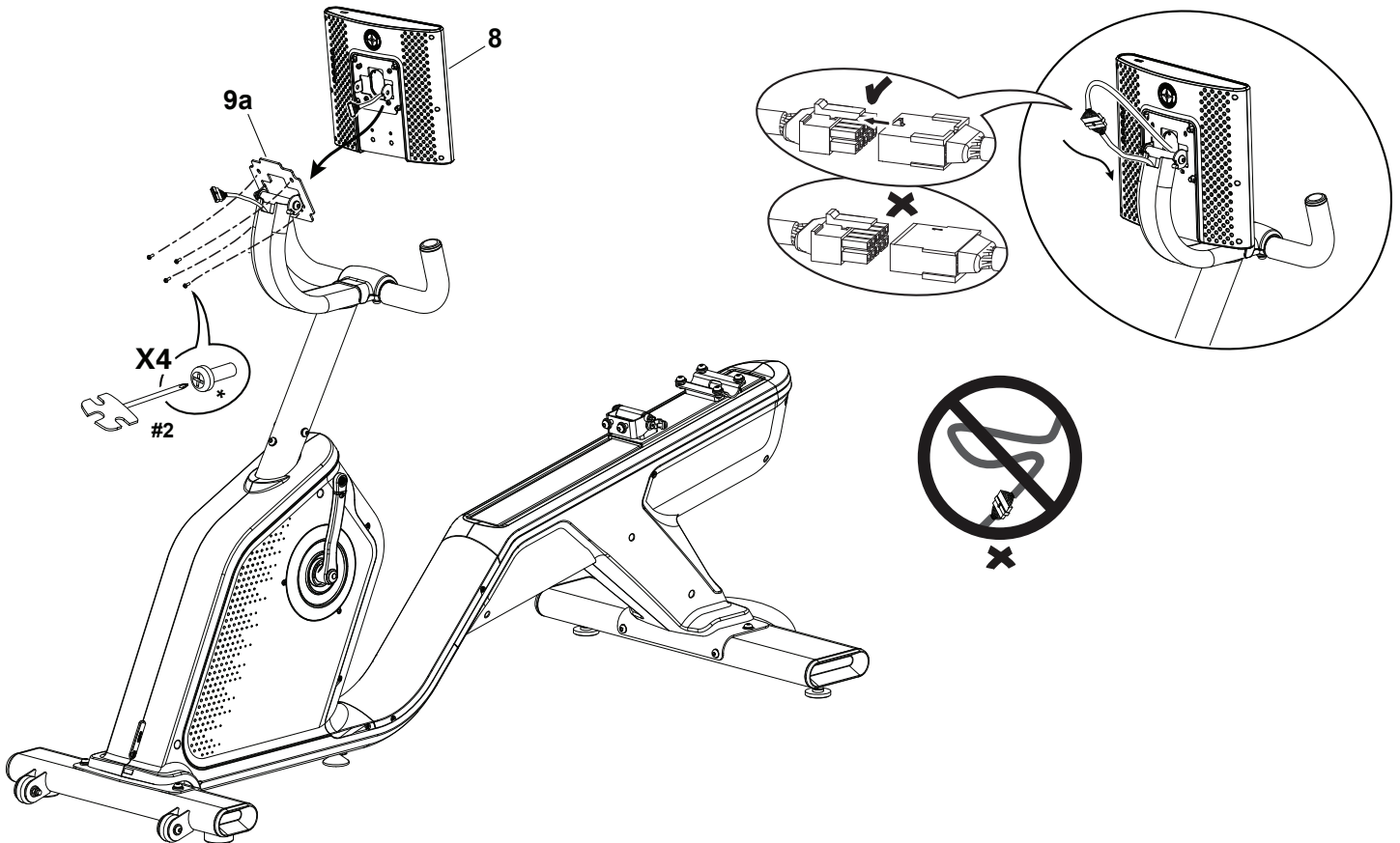

5c. Install the Pivot Cover and Media Tray

NOTICE: Do not cut or pinch the cables.

Note: Remove the adhesive backing from the Media Tray. Slide the tabs into the slots on the Console face and rotate the Media Tray downward. Press it firmly and evenly against the Console face to attach the adhesive surface securely.

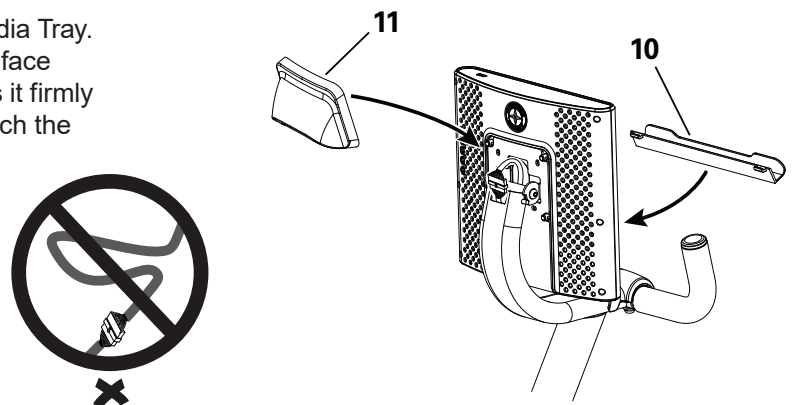

6. Remove the Support Struts from the Seat Frame and Attach the Seat Pad

NOTICE: Set the support struts (12a) and hardware (*) safely aside for Step 8. Attach the Seat Frame. Fully tighten the hardware.

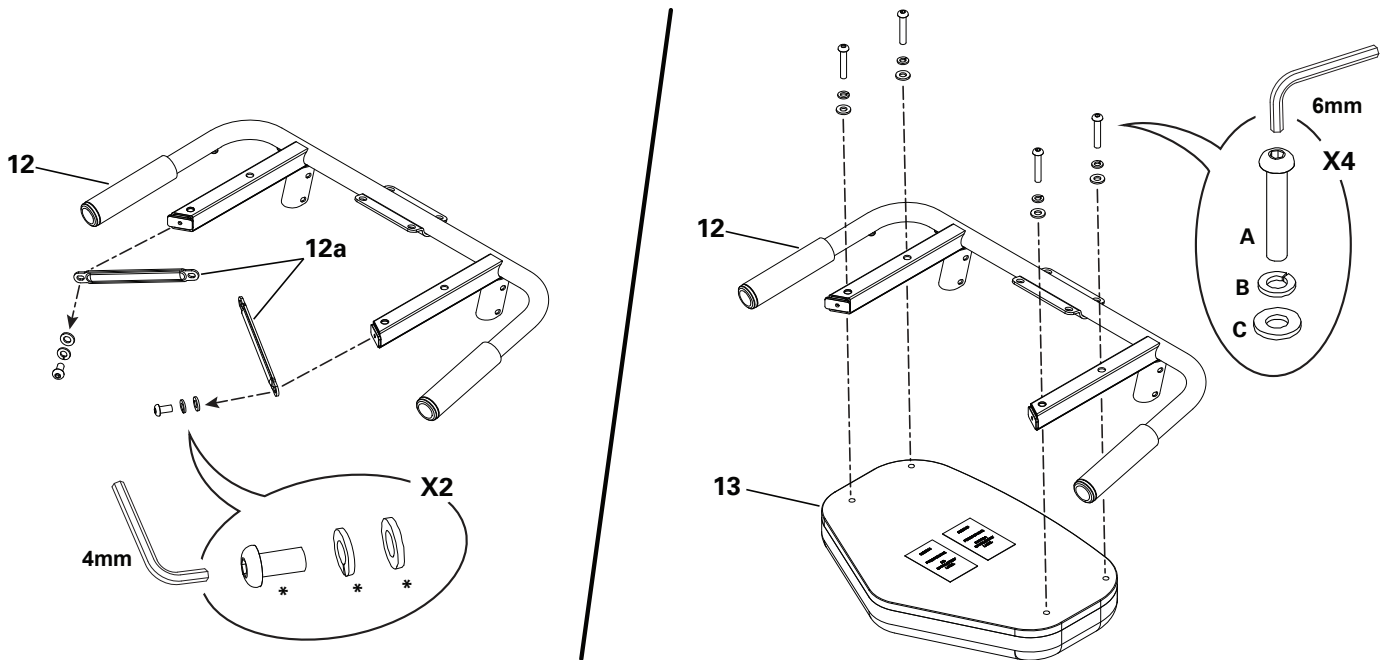

7. Attach the Support Struts and Seat Frame Assembly to the Seat Rail

NOTICE: Remove the pre-installed hardware (*) from the seat support bracket (1c) and hardware (**) from the handlebar support bracket (1d). Attach the struts (12a) to the seat support bracket (1c) using hardware (*). Hand tighten only. Attach the Seat Frame Assembly to the handlebar support bracket (1d) using the rest of the hardware (**). Hand tighten only.

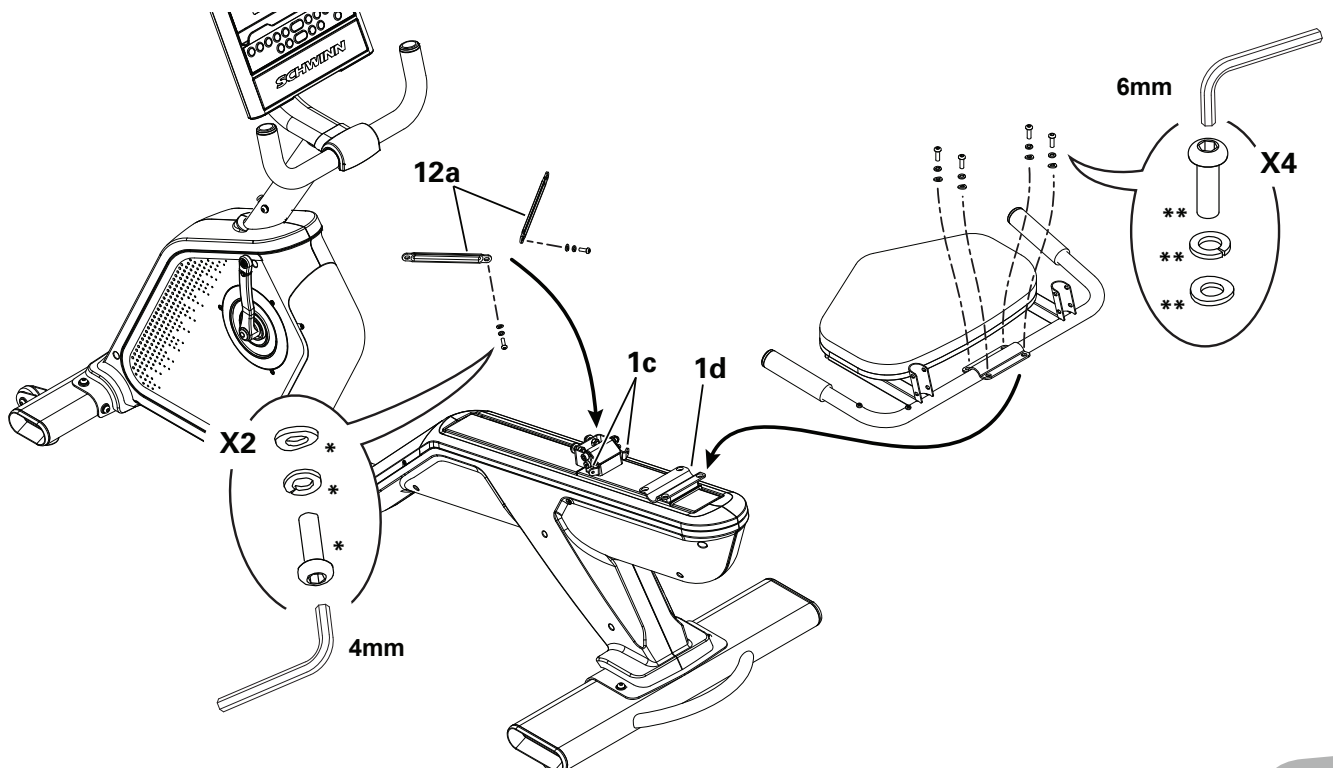

8. Attach the Support Struts to the Seat Frame Assembly

NOTICE: Rotate the Support Struts (12a) upward and re-install the hardware (*) from Step 6) to attach the struts to the Seat Frame (12). Hand tighten only. Once all hardware has been inserted, be sure to fully tighten all of the Seat Frame Assembly hardware from Steps 7 and 8.

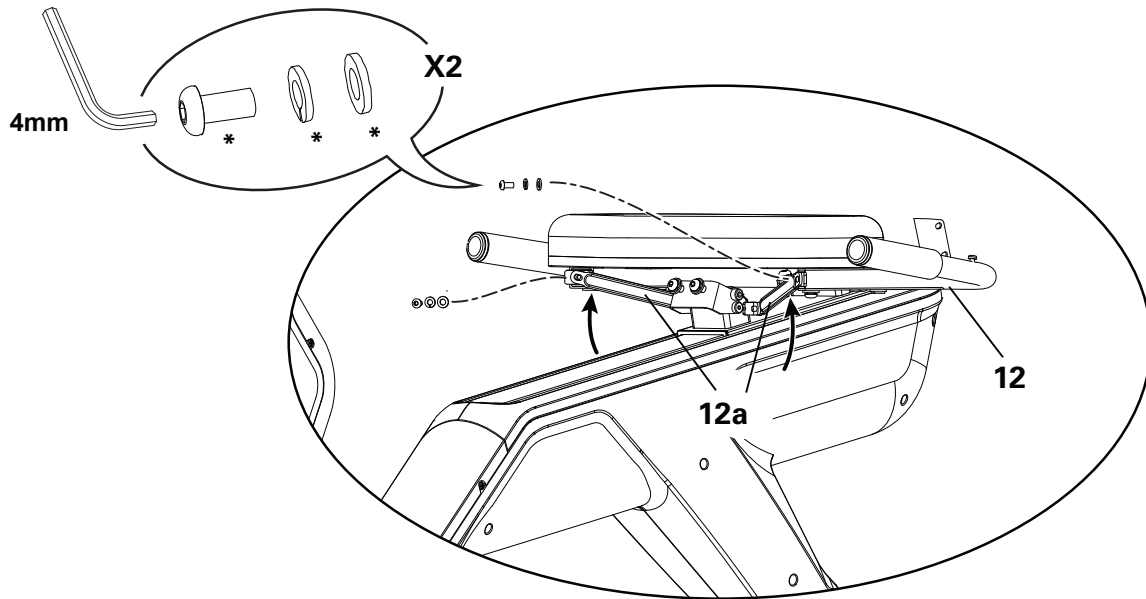

9. Attach the Seat Back to the Seat Frame Assembly

NOTICE: Hardware (*) is pre-installed on the Seat Back and not on the Hardware Card. Once all hardware has been inserted, be sure to fully tighten it.

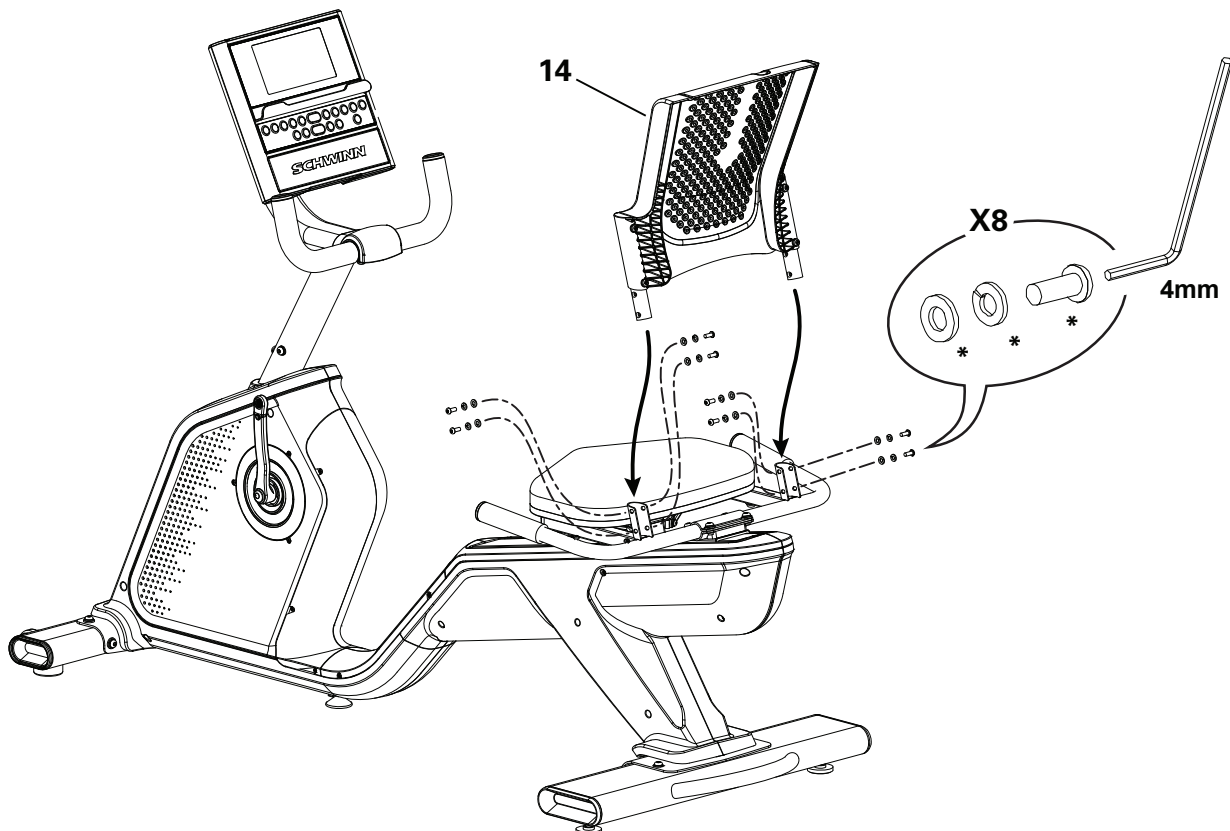

10. Attach Seat Adjustment Handle

NOTICE: Hardware (*) is pre-installed and not on the Hardware Card.

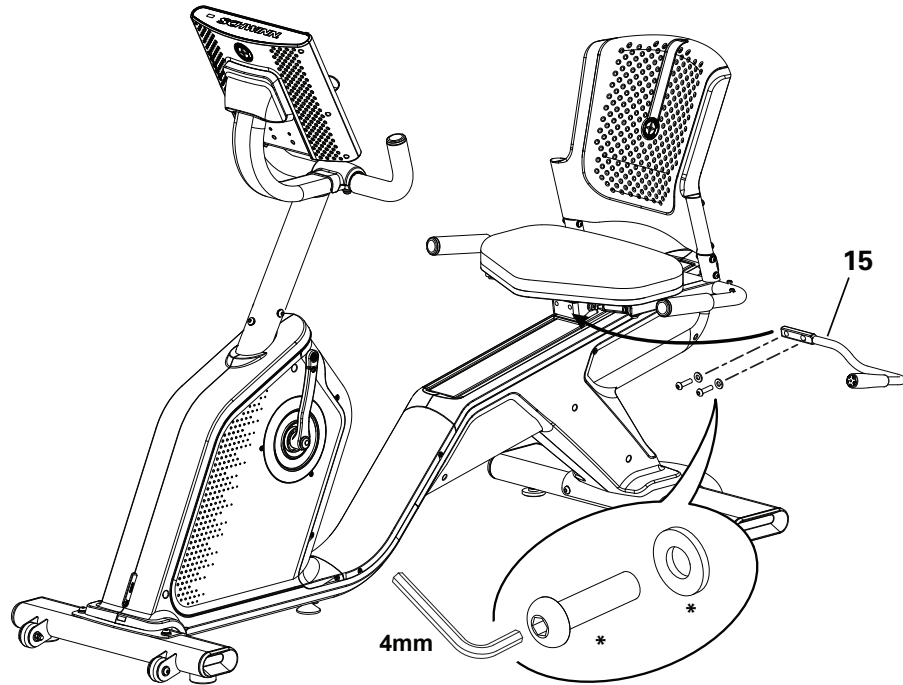

11. Attach Straps to Pedals and Install the Pedals

! If the threads strip due to improper installation, then the Pedals can disengage from the bike and/or break while under usage, which can result in serious injury to the user.

Note: The Left Pedal is reverse-threaded. Be sure to attach Pedals on the proper side of the Bike. Orientation is based from a seated position on the bike. The Left Pedal has an "L", the Right Pedal an "R". Start the Pedals by hand, and then fully tighten them with the Pedal Wrench. The Pedals must be fully tightened.

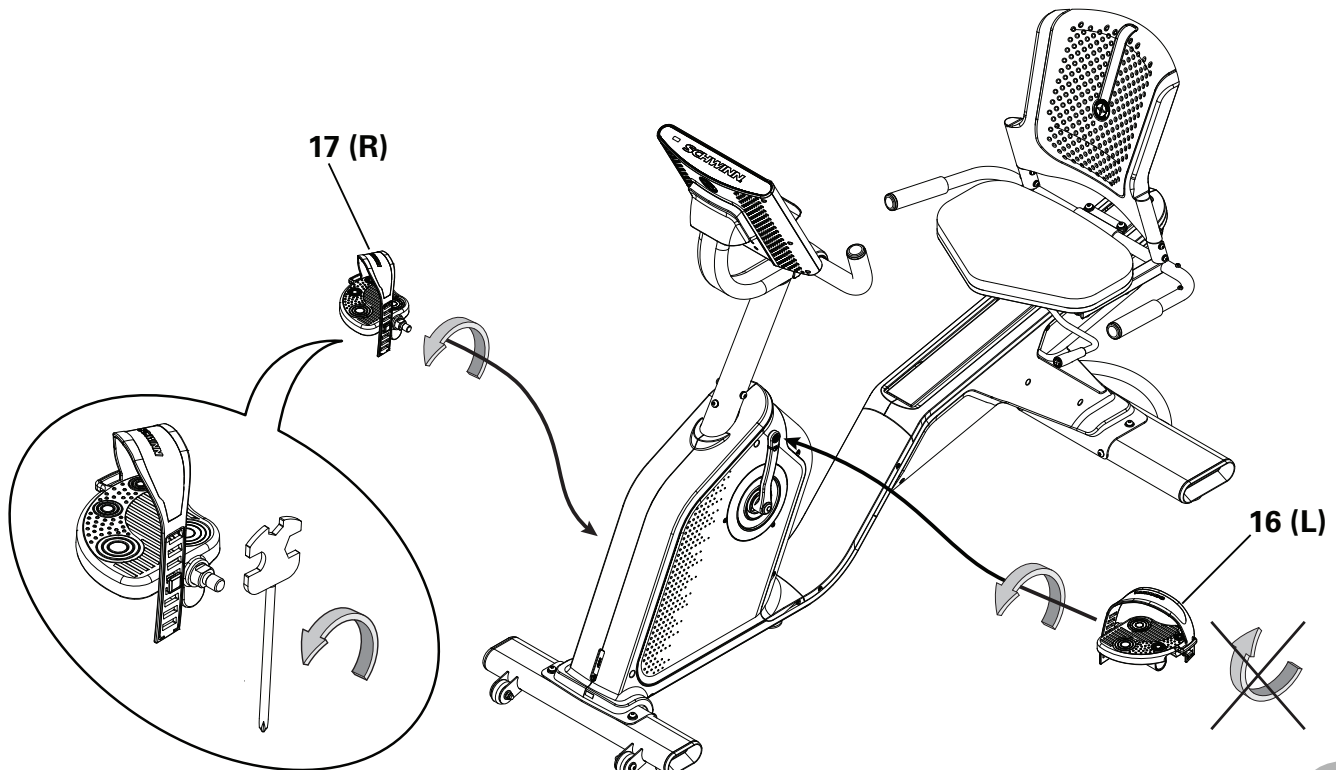

12. Attach Cup Holder to Frame Assembly

NOTICE: Hardware (*) is pre-installed and not on the Hardware Card.

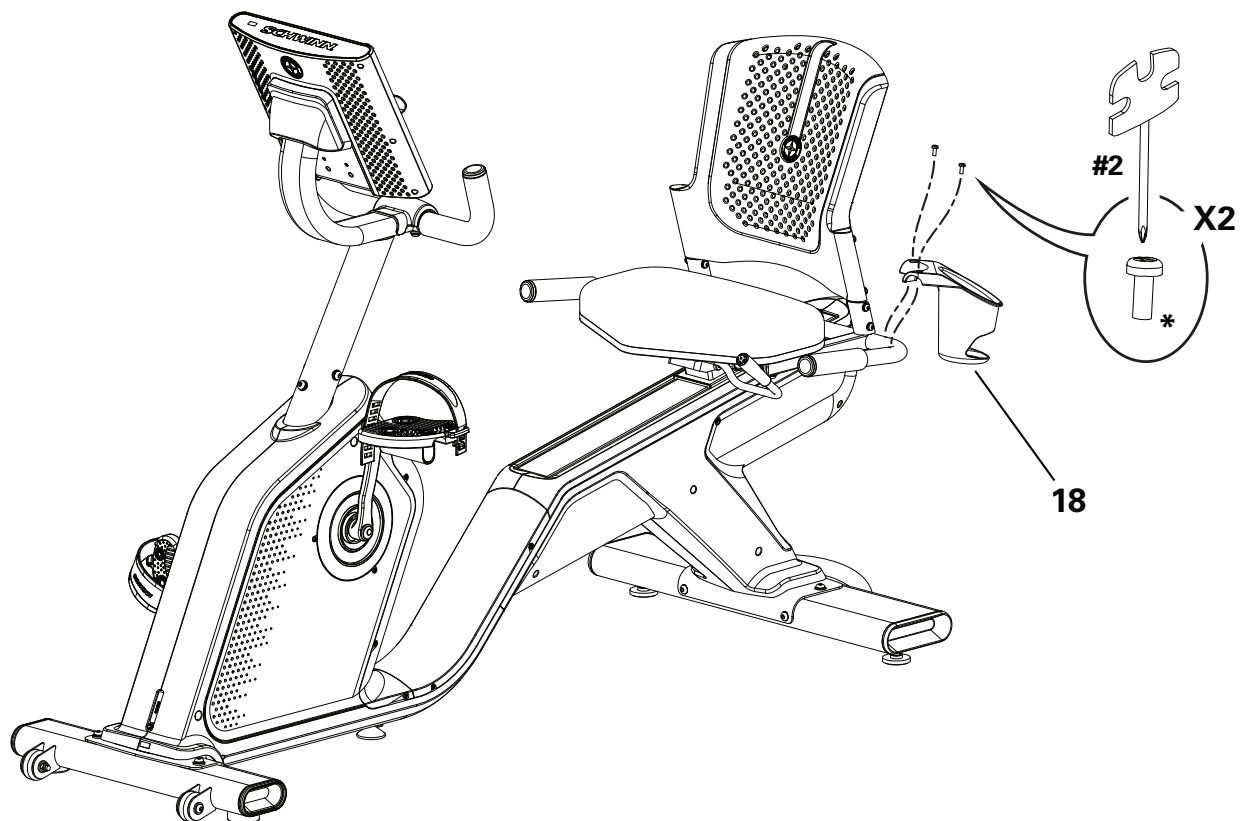

13. Adjust the Levelers As Necessary

Loosen the upper locking nut. Turn the leveler to adjust the height. Adjust the rear levelers until the machine is level. Tighten the locking nuts. Then adjust the middle leveler to contact the floor and tighten the locking nut. Make sure that the machine is level.

⚠ Do not adjust the levelers to such a height that they detach or unscrew from the machine. Injury to you or damage to the machine can occur.

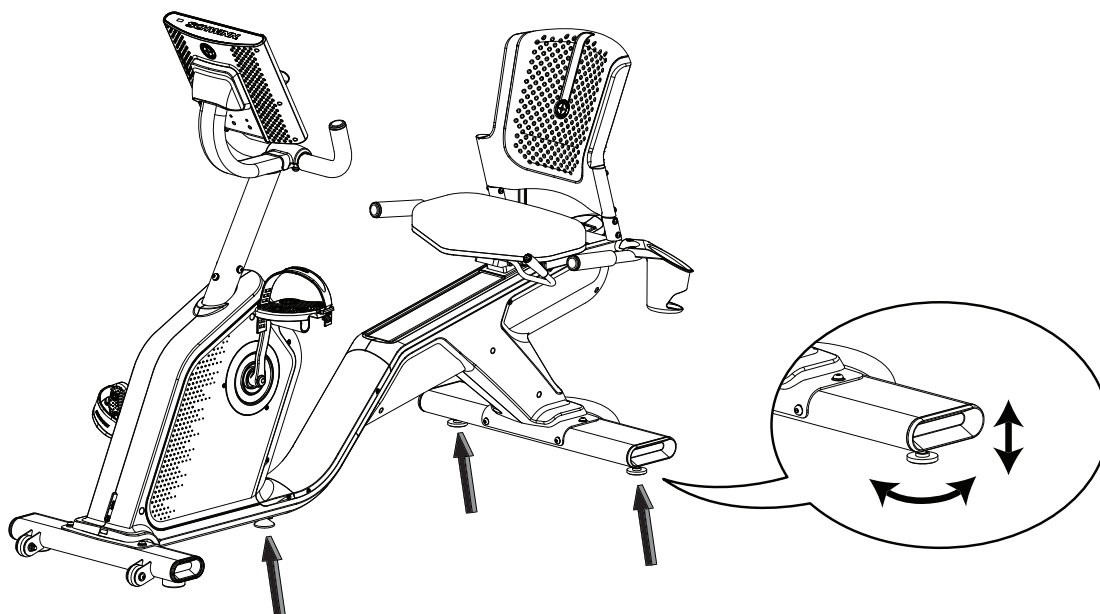

14. Connect AC Adapter to Frame Assembly

NOTICE: Make sure the connector is pushed all the way into the Power Inlet on the machine.

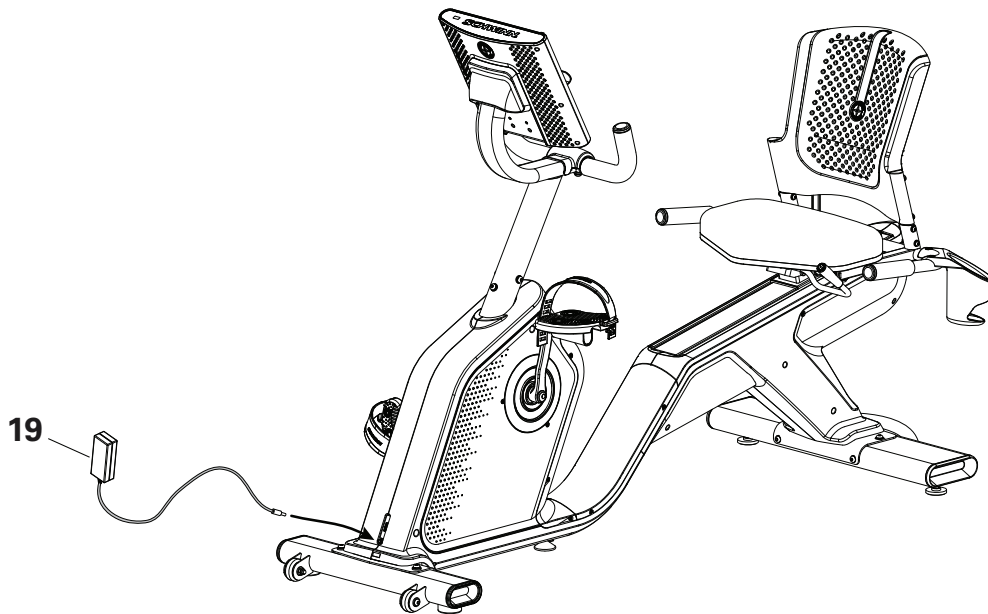

15. Final Inspection

Inspect your machine to ensure that all hardware is tight and components are properly assembled.

Be sure to record the serial number in the field provided at the front of this manual.

Carefully remove the protective plastic film from the display screen, keypad and top of the Console. Due to static electricity, "ghost" images may show on the screen but these will disappear after a few minutes.

⚠ Do not use until the machine has been fully assembled and inspected for correct performance in accordance with the Owner's Manual.

NOTICE: After your first few workouts, some hardware will need to be tightened again. To ensure quiet and smooth operation, make sure to tighten the indicated hardware after three workouts. Consult the Maintenance section of this manual for recommended future service intervals.

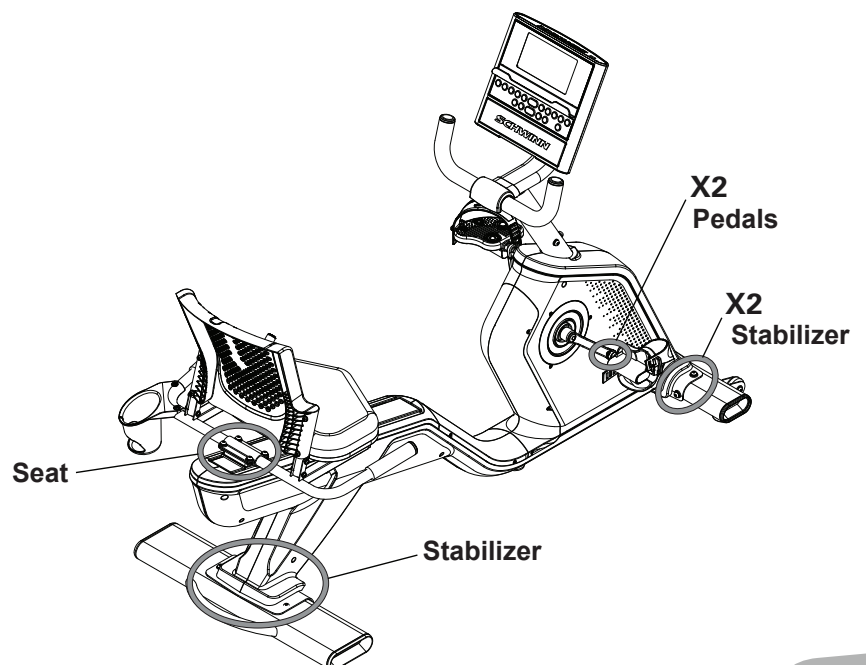

BEFORE YOU START

Moving the Machine

! The machine may be moved by one or more persons depending on their physical abilities and capacities. Make sure that you and others are all physically fit and able to move the machine safely.

1. Remove the power cord.
2. Use the Transport Handle to carefully lift the machine onto the transport rollers.
3. Push the machine into position.
4. Carefully lower the machine into position.

NOTICE: Be careful when you move the bike. Abrupt motions can affect the computer operation.

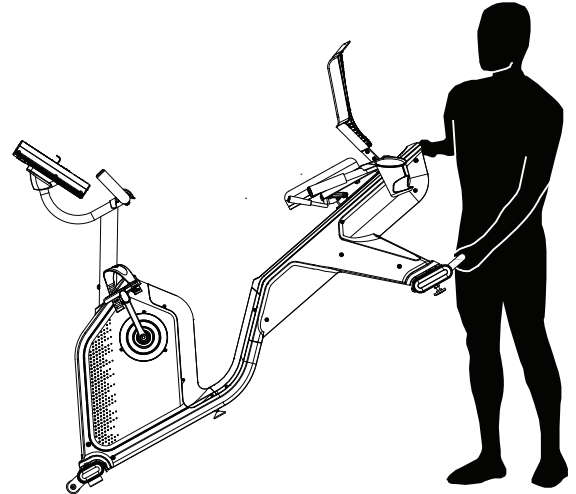

Leveling the Machine

Levelers are found on each side of the Rear Stabilizer and on the Frame Rail. Adjust the rear levelers until the machine is level. Then adjust the middle leveler to contact the floor.

1. Loosen the upper locking nut.
2. Turn the leveler to adjust the height.

! Do not adjust the levelers to such a height that they detach or unscrew from the machine. Injury to you or damage to the machine can occur.

3. Tighten the upper locking nut to lock the leveler.

Make sure the bike is level and stable before you exercise.

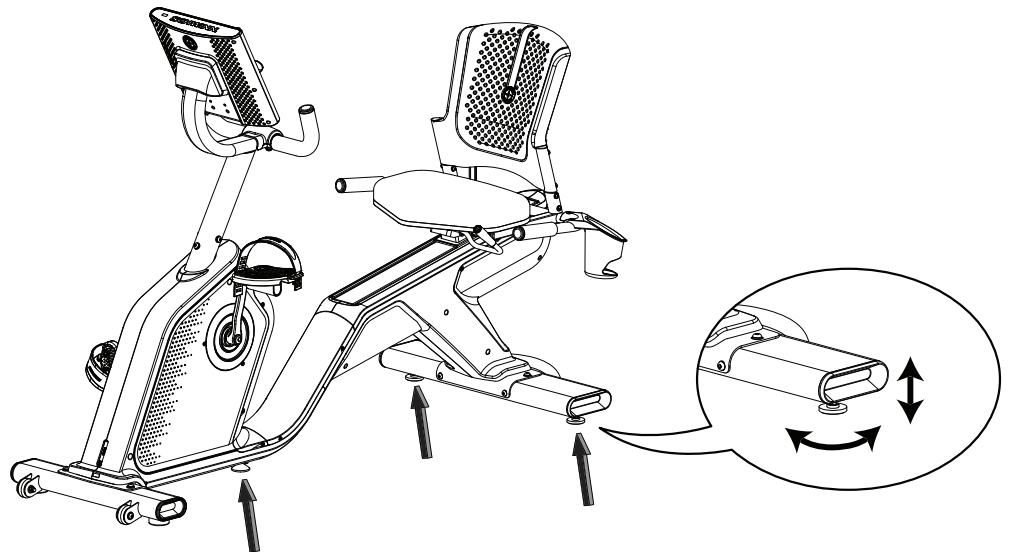

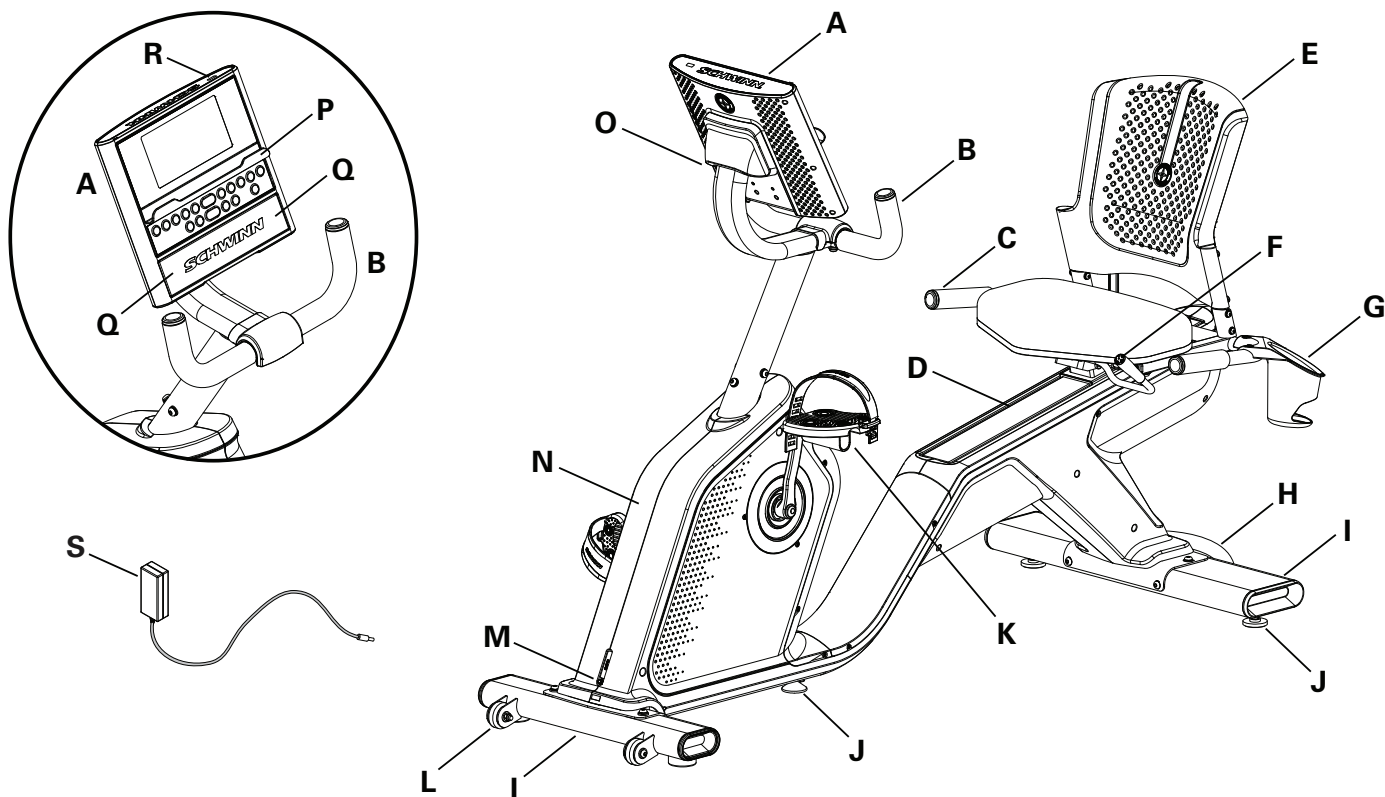

A	Console	L	Transport Roller
B	Handlebar, Upright	M	Power Connector
C	Handlebar, Side	N	Fully Shrouded Flywheel
D	Seat Rail	O	Adjustable Console Mount
E	Adjustable Seat	P	Media Tray
F	Seat Adjustment Handle	Q	Speakers
G	Cup Holder	R	USB Port
H	Transport Handle	S	AC Adapter
I	Stabilizer	T	Bluetooth® Heart Rate (HR) Receiver (not shown)
J	Leveler	U	Bluetooth® Connectivity (not shown)
K	Pedal		

WARNING! Use the values calculated or measured by the machine's computer for reference purposes only. The heart rate displayed is an approximation and should be used for reference only. Over exercising may result in serious injury or death. If you feel faint stop exercising immediately.

Console Features

The Console provides important information about your workout and lets you control the resistance levels while you exercise. The Console features touch control buttons to navigate you through the exercise programs.

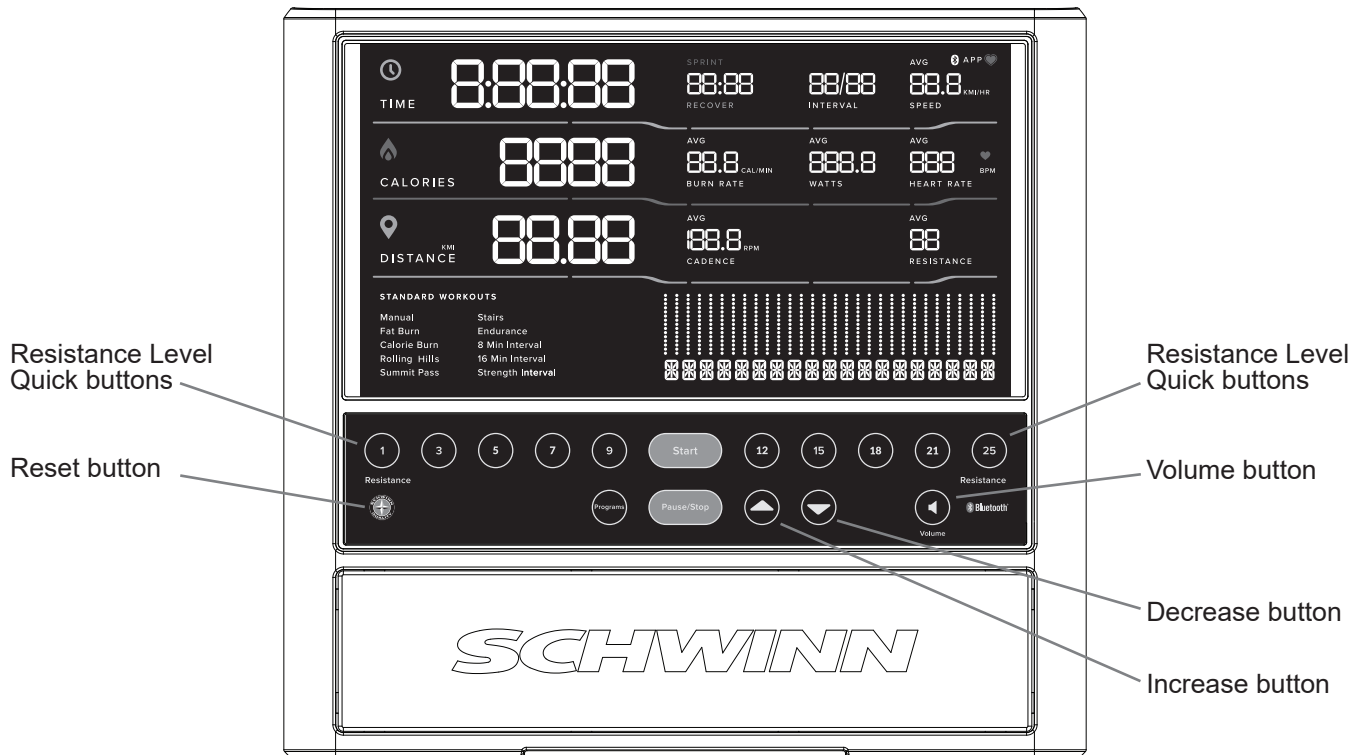

Keypad Functions

Resistance Level Quick buttons- Shifts the resistance level to the setting quickly during a workout.

Programs button- Tap to cycle through the menu of workout programs.

Start button- Starts a Program workout, confirms information, or resumes a paused workout.

Pause / Stop button- Pauses an active workout or ends a paused workout.

Increase (▲) button- Increases the workout resistance level or moves through options.

Decrease (▼) button- Decreases the workout resistance level or moves through options.

Volume button- Sets the sound level of the Console. Tap to cycle through the volume levels: Off, 1, 2 (default), 3. **It does not affect the output from your personal device.**

Reset button (Schwinn™ logo)- for service technician use only. When pushed during power up, the button restores the Console settings to the factory default state. The Console will require updates to be applied in order to become fully functional. Workout data is not affected.

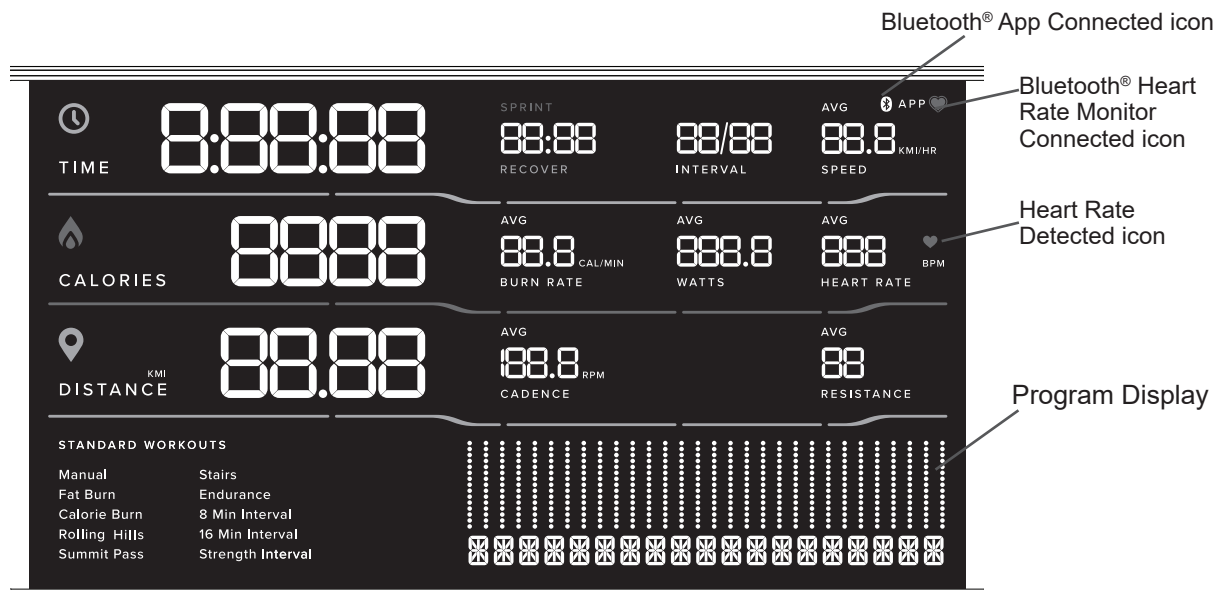

Console Display

Bluetooth® App Connected icon - Display shows when the Console is paired with the App.

Bluetooth® Heart Rate Monitor Connected icon - Display shows when the Console is paired with a Bluetooth® Heart Rate Monitor.

Heart Rate Detected icon - Display shows when the Console receives a heart rate signal from a Bluetooth® Heart Rate Monitor.

Time

The TIME display shows the total time count of the workout.

Interval

During an Interval workout, the INTERVAL display shows the currently active Interval and the total number of Intervals for the workout. Each Interval has a Sprint and a Recover workout segment.

Speed

The SPEED display shows the machine speed in miles per hour (mph) or kilometers per hour (km/h) .

Calories

The CALORIES display shows the estimated calories that you have burned during the exercise.

Burn Rate

The BURN RATE display shows the level of calories being burned per minute. This rate is a function of intensity, which is the current level of RPM (pedal speed) and resistance level. As either of those values increase, the Burn Rate will increase.

Watts

The WATTS display shows the estimated power output at the current RPM and intensity level, displayed in watts (746 watts = 1 hp).

Heart Rate (Pulse)

The HEART RATE display shows the beats per minute (BPM) from the heart rate monitor. When a heart rate signal is received by the Console, the icon will flash.

 **Consult a physician before you start an exercise program. Stop exercising if you feel pain or tightness in your chest, become short of breath, or feel faint. Contact your doctor before you use the machine again. The heart rate displayed is an approximation and should be used for reference only.**

Distance

The DISTANCE display shows the distance count (miles or km) in the workout. The maximum distance value is 99.99. The default distance unit is miles (MI).

Note: To switch units between kilometers and miles before a workout, push the Programs button and hold for 3 seconds to enter the Console Setup Mode. The System Units prompt appears. Push an Increase/Decrease button to change the units (KM/KG or MI/LB). With the desired unit of measurement displayed, push the Start button to save.

Cadence

The CADENCE display shows your current pedal speed in revolutions per minute (RPM).

Resistance

The RESISTANCE display shows the current resistance level in the workout.

Program Display

The Program Display shows information to the User and the grid display area shows the course profile for the program. Each column in the profile shows one interval (workout segment). The higher the column, the higher the resistance level. The flashing column shows your current interval.

USB Charging

If a USB Device is attached to the USB Port, the Port will attempt to charge the Device. Depending on the amperage of device, the power supplied from the USB Port may not be enough to operate the Device and charge it at the same time.

Workout with Other Fitness Apps

This fitness machine has integrated Bluetooth® connectivity which allows it to work with a number of fitness apps. For our latest list of supported apps, please visit: www.schwinnfitness.com

Using your JRNY™ membership with your machine

If you have a JRNY™ membership*, it can be accessed through your device when synced to the console of this Schwinn™ machine. With a JRNY™ membership, you receive guided workouts adapted to your capabilities, conveniently displayed on your device, and friendly virtual voice coaching designed to support you on your journey to long-term fitness success.

1. Download the app, named “JRNY™”. The app is available on the App Store and Google Play™.
2. Be sure that the Bluetooth® and Location Settings are active on your device. Activate them if necessary.
3. Open the app near the machine, and follow the instructions to sync your device to the machine.

If the app will not sync to the machine, restart your device and the machine. Repeat Step 3.

Bluetooth® Heart Rate Enabled

Your fitness machine is equipped to be able to receive a signal from a Bluetooth® Heart Rate Sensing device. When connected, the Console will display the Bluetooth® Heart Rate Monitor Connected icon. Be sure to follow the described method to sync your device.

 **If you have a pacemaker or other implanted electronic device, consult your doctor before using a Bluetooth® strap or other Bluetooth® heart rate monitor.**

Bluetooth® Heart Rate Monitor

Your fitness machine is equipped to be able to receive a signal from a Bluetooth® Heart Rate (HR) Monitor. Follow the instructions provided with your Bluetooth® HR monitor.

 **If you have a pacemaker or other implanted electronic device, consult your doctor before using a Bluetooth® armband or other Bluetooth® heart rate monitor.**

* A JRNY™ membership is required for the JRNY™ experience – see www.schwinnfitness.com/jrny for details. For United States and Canada customers, you can obtain a JRNY™ membership by calling 800-269-4126 or visiting www.schwinnfitness.com/jrny. Where available (including the United States), you can also obtain a JRNY™ membership by downloading the JRNY™ app onto your phone or tablet and signing up within the downloaded app. JRNY™ memberships may not be available in all countries.

Note: Be sure to remove the protective cover (if provided) from the Heart Rate Sensor before use.

1. Put on your Bluetooth® Heart Rate monitor and activate it.
2. The Console will actively search for any monitors in the area, and will rapidly flash the Bluetooth® Heart Rate Monitor Connected icon.
3. When connected, the Bluetooth® Heart Rate Monitor Connected icon will flash with your pulse and your current heart rate value will be displayed on the Console. You are now ready to work out.

Heart Rate Calculations

Your maximum heart rate usually decreases from 220 Beats Per Minute (BPM) in childhood to approximately 160 BPM by age 60. This fall in heart rate is usually linear, decreasing by approximately one BPM for each year. There is no indication that training influences the decrease in maximum heart rate. Individuals of the same age could have different maximum heart rates. It is more accurate to find this value by completing a stress test than by using an age related formula.

Your at-rest heart rate is influenced by endurance training. The typical adult has an at rest heart rate of approximately 72 BPM, whereas highly trained runners may have readings of 40 BPM or lower.

The Heart Rate table is an estimate of what Heart Rate Zone (HRZ) is effective to burn fat and improve your cardiovascular system. Physical conditions vary, therefore your individual HRZ could be several beats higher or lower than what is shown.

The most efficient procedure to burn fat during exercise is to start at a slow pace and gradually increase your intensity until your heart rate reaches between 60 – 85% of your maximum heart rate. Continue at that pace, keeping your heart rate in that target zone for over 20 minutes. The longer you maintain your target heart rate, the more fat your body will burn.

The graph is a brief guideline, describing the generally suggested target heart rates based on age. As noted above, your optimal target rate may be higher or lower. Consult your physician for your individual target heart rate zone.

Note: As with all exercises and fitness regimens, always use your best judgment when you increase your exercise time or intensity.

FAT-BURNING TARGET HEART RATE

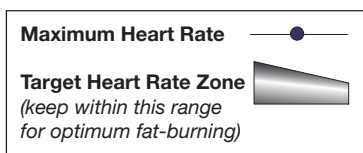
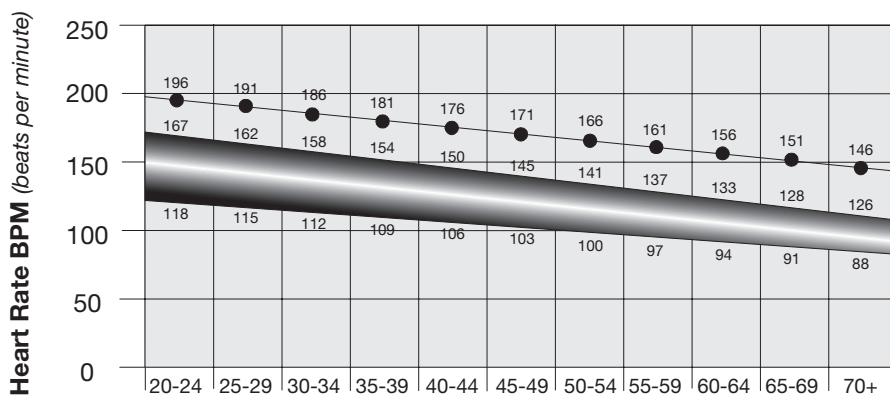

What to Wear

Wear rubber-soled athletic shoes. You will need the appropriate clothes for exercise that allow you to move freely.

How Often Should You Exercise

⚠️ Consult a physician before you start an exercise program. Stop exercising if you feel pain or tightness in your chest, become short of breath, or feel faint. Contact your doctor before you use the machine again. Use the values calculated or measured by the machine's computer for reference purposes only. The heart rate displayed on the console is an approximation and should be used for reference only.

- 3 times a week for 30 minutes each day.
- Schedule workouts in advance and try to follow the schedule.

Seat Adjustment

Correct seat placement encourages exercise efficiency and comfort, while reducing the risk of injury.

1. With a Pedal in the forward position, place the ball of your foot over the center of it. Your leg should be bent slightly at the knee.
2. If your leg is too straight or your foot cannot touch the Pedal, move the seat forward. If your leg is bent too much, move the seat toward the back.

⚠️ Step off the bike before you adjust the seat.

3. Pull up on the Seat Adjustment Handle, and adjust the seat to the desired position.
4. Push the Seat Adjustment Handle down firmly to engage the locking mechanism. Be sure that the handle is fully engaged.

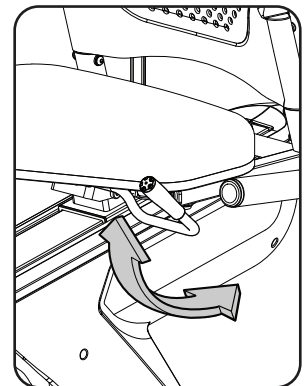

Foot Position / Pedal Strap Adjustment

Foot pedals with straps provide secure footing to the exercise bike.

1. Rotate the Pedals until one can be reached.
2. Put the ball of each foot on the Pedals.
3. Fasten the strap over the shoe.
4. Repeat for the other foot.

Be sure toes and knees point directly forward to ensure maximum Pedal efficiency. Pedal straps can be left in position for subsequent workouts.

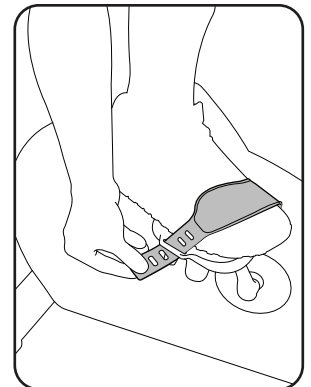

Power-Up / Idle Mode / Welcome screen

The Console will enter Power-Up / Idle Mode if it is plugged into a power source, any button is pushed, or if it receives a signal from the RPM sensor as a result of pedaling the machine.

Auto Shut-Off (Sleep Mode)

If the Console does not receive any input in approximately 5 minutes, it will automatically shut off. The LCD display is off while in Sleep Mode.

Note: The Console does not have an On/Off switch.

Manual (Quick Start) Program

The Manual (Quick Start) program lets you start a workout without entering any information.

During a Manual Workout, each column represents a 1 minute time period. The active column will advance across the screen every minute. If the workout lasts for more than 18 minutes, the active column will stay to the right where an additional column is added to the workout program.

1. Sit on the machine.
2. Push Start to begin the workout.

To change the resistance level, push the Resistance Increase/Decrease buttons. The current interval and future intervals are set to the new level. The default Manual resistance level is 4. The time will count up from 00:00.

Note: If a Manual workout is performed for more than 9 hours 99 minutes and 59 seconds (9:99:59), the units for Time will reset to zero. Be sure to add these values to your final workout results.

3. When done with your workout, stop pedaling and push Pause/Stop to pause the workout. Push Pause/Stop again to end the workout.

Profile Programs

The Profile programs automate different resistance and workout levels.

1. Sit on the machine.
2. Tap the Programs button to cycle through the menu of workout programs to the desired workout.
3. Push Start to begin the workout.

To change the resistance level, push the Increase/Decrease buttons.

4. When done with your workout, stop pedaling and push Pause/Stop to pause the workout. Push Pause/Stop again to end the workout.

Interval Programs

During the Interval Programs, the workout will switch between an increased intensity, "Sprint" period (more resistance), and a slower paced, "catch your breath" time period ("Recover", or less resistance). This shift between Sprint and Recover is repeated over the entire workout. For example, in the 8 Min Interval program the "Sprint" period is 30 seconds, and the "Recover" period is 90 seconds.

Note: Each "Recover" period is represented by 2 columns on the display.

⚠ The "Sprint" period of an Interval Program is a suggested increase in resistance level and speed, and should only be followed if your physical fitness level allows.

Endurance

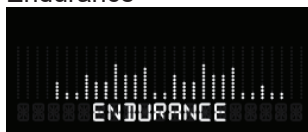

8 Min Interval



16 Min Interval



Strength Interval



Non-Interval Programs

Fat Burn



Calorie Burn



Rolling Hills



Summit Pass



Stairs



Modify Display of Workout Values

To switch units between kilometers and miles before a workout, push the Programs button and hold for 3 seconds to enter the Console Setup Mode. The System Units prompt appears. Push an Increase/Decrease button to change the units (KM/KG or MI/LB). With the desired unit of measurement displayed, push the Start button to save.

Note: The default system of measurement is MI/LB.

Changing Resistance Levels

Push the Increase(▲) or Decrease(▼) buttons to change the resistance level at any time in a workout program. To rapidly change the resistance level, push the desired Resistance Level Quick Button. The Console will adjust to the selected resistance level of the Quick button.

Pausing or Stopping

1. Push the Pause/Stop button or stop pedaling for 5 seconds to pause your workout.
2. To continue your workout, push Start or begin pedaling.

To stop the workout, push the Pause/Stop button. The Console will go into Workout Summary mode. Push PAUSE/STOP again to exit to the Welcome screen.

Muting the Console

The Console has the option to be muted. To disable the audible cues, tap the Volume button to cycle through the volume levels: Off, 1, 2 (default), 3. **It does not affect the output from your personal device.**

Note: The Console will reset to the last volume setting for the selected User Profile after each power-up.

Workout Summary Mode

After a workout, the Console display will show “Workout Complete” then “Saving Workout”. The Console will show the Workout Summary values for 5 minutes. The workout must be longer than 1 minute in order to store the data.

The summary includes total and average workout values. The total workout values are Distance, Time, Calories and Intervals Completed. The average workout values are Sprint Burn Rate, Cadence, Heart Rate (if available) and Resistance.

Note: If no Heart Rate was provided during the workout, the Console will not report a value.

The Workout Summary will end after 5 minutes or if the Pause/Stop button is pushed.

Console Setup Mode – System Menu

The Console Setup Mode allows you to set units of measurement to either Imperial or metric, adjust screen brightness, view maintenance statistics (such as Run Time Hours and software version – for service technician use only), or reset the Console.

1. Push the Programs button and hold for 3 seconds while in the Power-Up Mode to go into the Console Setup Mode (System Menu).

Note: Push the Pause/Stop button to exit the System Menu and return to the Power-Up Mode screen.

2. The Console display shows the System Units prompt with the current setting. The default setting is Imperial English units. Push the Increase/Decrease buttons to change between Imperial (MI/LB) and metric (KM/KG).

Note: If the units change when there is data in User Statistics, the statistics convert to the new units.

3. Push the Programs button to set the selection and continue to the next menu option.

Note: To save the selection and exit the System Menu, push the Start button. To exit without saving, push the Pause/Stop button.

4. The Console display shows the Disconnect Bluetooth prompt. The default option is NO. The YES option will disconnect all Bluetooth® devices. Push the Increase/Decrease buttons to change between options (YES/NO).

5. Push the Programs button to set the selection and continue to the next menu option.

6. The Console display shows the LCD Brightness prompt and lists the 5 levels of brightness: 100%, 95% (default), 90%, 85%, 80%. The current brightness level blinks. Push the Increase/Decrease buttons to move to the desired level.

7. Push the Programs button to set the selection and continue to the next menu option.

8. The Console display shows the Hardware Variant & Console Firmware Version.

9. Push the Programs button to continue to the next menu option.

10. The Console display shows the Base Serial Number.

11. Push the Programs button to continue to the next menu option.

12. The Console display shows the Hardware Variant (machine type).

13. Push the Programs button to set the selection and continue to the next menu option.

14. The Console display shows the Run Time Hours (total number of hours of workout time).

15. Push the Programs button to continue to the next menu option.

16. The Console display shows the BLE Version.
 17. Push the Programs button to continue to the next menu option.
 18. The Console display shows the BTC Version.
 19. Push the Programs button to continue to the next menu option.
 20. The Console display shows the EX SNSR Version.
 21. Push the Programs button to continue to the next menu option.
 22. The Console display shows the View Error Messages prompt (for service technician use only). The default option is NO. The YES option will show the active error messages. Push the Increase/Decrease buttons to change between options (YES/NO).
 23. Push the Programs button to continue to the next menu option.
 24. The Console display shows the Clear Error Messages prompt (for service technician use only). The default option is NO. The YES option will clear the log of all errors. Push the Increase/Decrease buttons to change between options (YES/NO).
 25. Push the Programs button to continue to the next menu option.
 26. The Console display shows the Reset prompt. The default option is NO. Push the Pause/Stop button to exit without starting Reset.
 - Note:** The YES option will reset the System Units, LCD Brightness and Demo Mode to default settings. It does not reset the Run Time Hours.
- Push the Increase/Decrease buttons to change between options (YES/NO).
- Push the Start button to set the selection and exit the System Menu.
27. The Console will display the Power-Up Mode screen.

MAINTENANCE

Read all maintenance instructions fully before you start any repair work. In some conditions, an assistant is necessary to do the necessary tasks.

⚠ Equipment must be regularly examined for damage and repairs. The owner is responsible to make sure that regular maintenance is done. Worn, damaged or loose components must be repaired or replaced immediately. Only manufacturer supplied components can be used to maintain and repair the equipment.

If at any time the Warning labels become loose, unreadable or dislodged, replace the labels. If purchased in US/Canada, contact Customer Service for replacement labels. If purchased outside US/Canada, contact your local distributor for them.

Disconnect all power to the machine before you service it.

Daily: Before each use, examine the exercise machine for loose, broken, damaged, or worn parts. Do not use if found in this condition. Repair or replace all parts at the first sign of wear or damage. Check Pedals and tighten as necessary. After each workout, use a damp cloth to wipe your machine and Console free of moisture.

Note: Avoid excessive moisture on the Console.

NOTICE: If necessary, only use a mild dish soap with a soft cloth to clean the Console. Do not clean with a petroleum based solvent, automotive cleaner, or any product that contains ammonia. Do not clean the Console in direct sunlight or at high temperatures. Be sure to keep the Console free of moisture.

Weekly: Check pedals and crank arms and tighten as necessary.

⚠ Do not back, or reverse, pedal. Doing so may loosen the Pedals, which could result in damage to the machine and/or injury to the user. Never operate this machine with loose Pedals

Clean the machine to remove any dust, dirt, or grime from the surfaces. Check for smooth seat slider operation. If needed, apply a very thin coating of 100% silicone lubricant to ease operation.

⚠ Silicone lubricant is not intended for human consumption. Keep out of reach of children. Store in a safe place.

Note: Do not use petroleum based products.

Monthly or after 20 hours: Make sure all bolts and screws are tight. Tighten as necessary.

⚠ When the machine is used in a Studio/Institutional environment, we recommend that the Pedals be replaced every year to maintain maximum user safety and performance. Only use replacement Pedals available from Nautilus. Other brands of Pedals may not be designed for this product, and can cause danger to users and bystanders, and will void the warranty.

Maintenance Parts

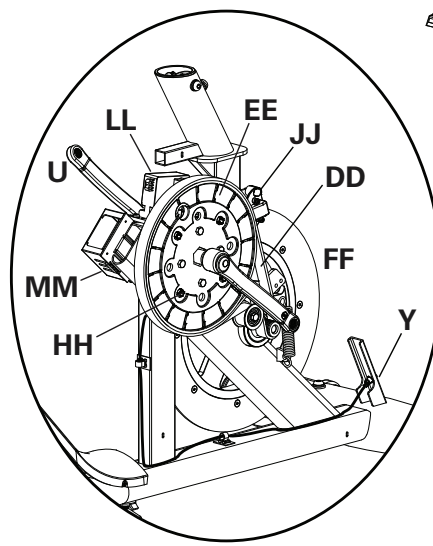
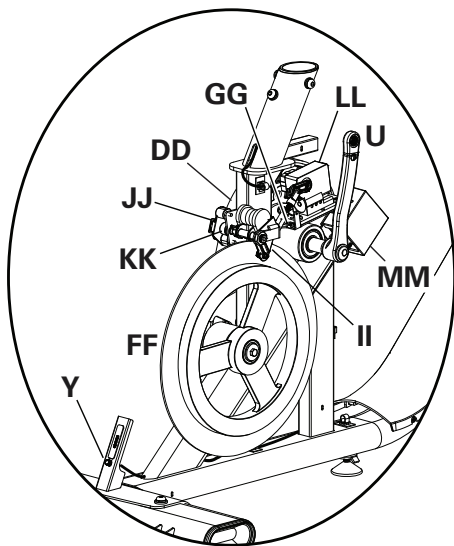
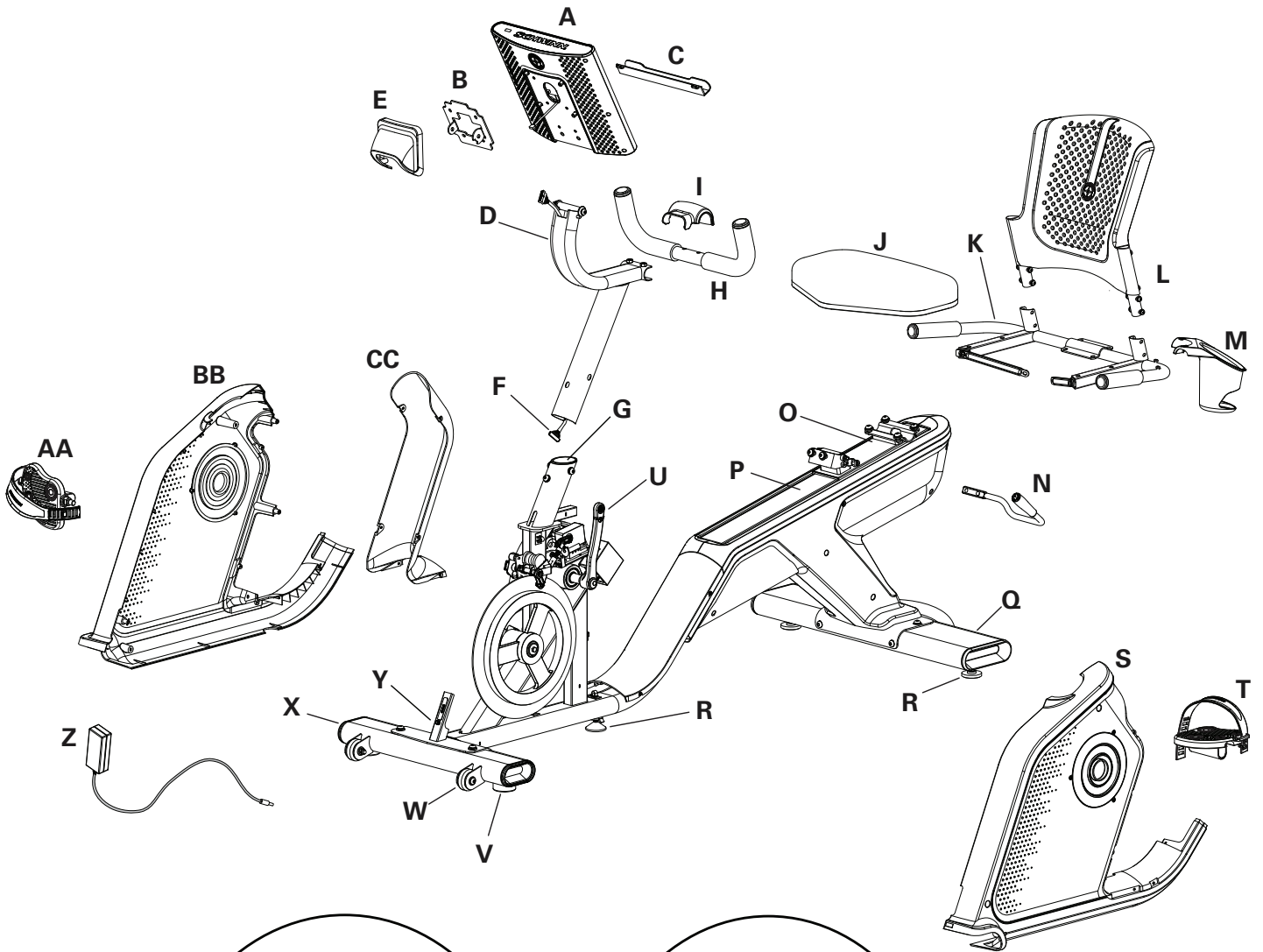

A	Console	N	Seat Adjustment Handle	AA	Pedal, Right
B	Console Mount Bracket	O	Seat Slider	BB	Shroud, Right Main
C	Media Tray	P	Seat Rail	CC	Shroud, Engine Rear
D	Console Mast	Q	Rear Stabilizer	DD	Drive Belt
E	Pivot Cover	R	Levelers	EE	Drive Pulley
F	Data Cable, Upper	S	Shroud, Left Main	FF	Flywheel
G	Insert, Lower Mast	T	Pedal, Left	GG	RPM (Speed) Sensor
H	Handlebar, Upright	U	Crank Arm	HH	Speed Sensor Magnet (4)
I	Handlebar Mount Cover	V	Stabilizer Feet	II	Magnet Carriage
J	Seat Pad	W	Transport Roller	JJ	Resistance Sensor
K	Seat Frame	X	Front Stabilizer	KK	Resistance Magnet
L	Seat Back	Y	Power Connector	LL	Servo Motor
M	Cup Holder	Z	AC Adapter	MM	PCBA/Mount Assembly

Condition/Problem	Things to Check	Solution
No display/partial display/ unit will not turn on	Check electrical (wall) outlet	Make sure unit is plugged into a functioning wall outlet.
	Check connection at front of unit	Connection should be secure and undamaged. Replace adapter or connection at unit if either are damaged.
	Check data cable integrity	All wires in cable should be intact. If any are visibly pinched or cut, replace cable.
	Check data cable connections/orientation	Be sure cables at base of mast and at back of console are connected securely and oriented properly. Small latch on connector should line up and snap into place.
	Check console display for damage	Check for visual sign that console display is cracked or otherwise damaged. Replace Console if damaged.
	Console Display	If Console only has partial display and all connections are fine, replace the Console.
		If the above steps do not resolve the problem, contact Customer Service (if inside US/Canada) or your local distributor (if outside US/Canada).
Console display shows "0 Base Hub Comm Error" error code	Check data cable integrity	All wires in cable should be intact. If any are visibly pinched or cut, replace cable.
	Check data cable connections/orientation	Be sure cables at base of mast and at back of console are connected securely and oriented properly. Small latch on connector should line up and snap into place.
	Check console display for damage	Check for visual sign that console display is cracked or otherwise damaged. Replace Console if damaged.
		If the above steps do not resolve the problem, contact Customer Service (if inside US/Canada) or your local distributor (if outside US/Canada).
Console display shows "3 Stuck Button Error" error code	Check console keypad	Check for stuck buttons on the Console keypad. Replace Console if damaged.
		If the above steps do not resolve the problem, contact Customer Service (if inside US/Canada) or your local distributor (if outside US/Canada).
Console display shows "5 NVRAM Error" error code	Console	Indicates problem with flash memory on Console. Contact Customer Service (if inside US/Canada) or your local distributor (if outside US/Canada).
Unit operates but Bluetooth® HR not displayed	HR monitor (not provided)	Follow the troubleshooting instructions provided with the device.
	HR monitor batteries	If monitor has replaceable batteries, install new batteries.
	Interference	Try moving unit away from sources of interference (TV, Microwave, etc).
	Replace HR monitor	If interference is eliminated and HR does not function, replace HR monitor.
	Replace Console	If HR still does not function, replace Console.
No speed/RPM reading, Console displays "Please Pedal" error code	Check data cable integrity	All wires in cable should be intact. If any are cut or pinched, replace cable.
	Check data cable connections/orientation	Be sure each cable is connected securely and oriented properly. Small latch on connector should line up and snap into place.

Condition/Problem	Things to Check	Solution
	Check magnet position (requires shroud removal)	Magnet should be in place on pulley.
	Check Speed Sensor (requires shroud removal)	Speed sensor should be aligned with magnet and connected to data cable. Realign sensor if necessary. Replace if there is any damage to the sensor or the connecting wire.
Resistance does not change (machine turns on and operates)	Check data cable integrity	All wires in cable should be intact. If any are visibly pinched or cut, replace cable.
	Check data cable connections/orientation	Be sure cable is connected securely and oriented properly. Reseat all connections. Small latch on connector should line up and snap into place.
	Check Servo Motor (requires shroud removal)	If magnets move, adjust until they are within the proper range. Replace Servo Motor if not functioning properly.
	Check Console	Check for visual sign that Console is damaged. Replace Console if damaged.
		If the above steps do not resolve the problem, contact Customer Service (if inside US/Canada) or your local distributor (if outside US/Canada) for further assistance.
Console shuts off (enters sleep mode) while in use	Check electrical (wall) outlet	Make sure unit is plugged into a functioning wall outlet.
	Check connection at front of unit	Connection should be secure and undamaged. Replace adapter or connection at unit if either are damaged.
	Check data cable integrity	All wires in the cable should be intact. If any are pinched or cut, replace cable.
	Check data cable connections/orientation	Be sure cable is connected securely and oriented properly. Small latch on connector should line up and snap into place.
	Reset machine	Unplug unit from electrical outlet for 3 minutes. Reconnect to outlet.
	Check magnet position (requires shroud removal)	Magnet should be in place on pulley.
	Check Speed Sensor (requires shroud removal)	Speed sensor should be aligned with magnet and connected to data cable. Realign sensor if necessary. Replace if there is any damage to the sensor or the connecting wire.
Unit rocks/does not sit level	Check leveler adjustment	Adjust levelers until bike is level.
	Check surface under unit	Adjustment may not be able to compensate for extremely uneven surfaces. Move bike to level area.
Pedals loose/unit difficult to pedal	Check pedal to crank arm connection	Pedal should be tightened securely to crank. Insure connection is not cross-threaded.
Clicking sound when pedaling	Check pedal to crank arm connection	Remove pedals. Make sure there is no debris on threads, and reinstall the pedals.
Pedals loose/unit difficult to pedal	Check pedal to crank connection	Pedal should be tightened securely to crank. Be sure connection is not cross threaded.
Seat Assembly shifts / squeaks when in use	Hardware	Check hardware that attaches Seat assembly, and fully tighten hardware.
Console continuously cycles through program screens	Console is in demonstration mode	Press and hold the Schwinn™ logo button for 3 seconds. The setting will take effect after the next time the machine goes into Sleep Mode.



