

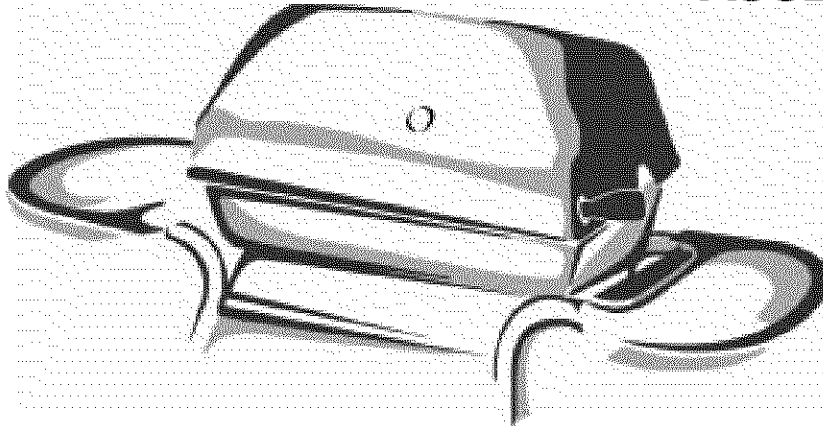

# Liquid Propane Gas Grill

Model No. 415.162120

This Grill Is For  
Outdoor Use Only



## WARNING

- Read this manual before cooking on grill. Failure to follow all manufacturer's instructions could result in fire or explosion which could cause property damage, personal injury or death.
- Combustion by-products produced when using this product contain chemicals known to the State of California to cause cancer, birth defects, or other reproductive harm.

## CAUTION

- Read and follow all Safety Statements, Assembly Instructions and Use & Care Directions before attempting to assemble and cook.
- Some parts may contain sharp edges, especially as noted in these instructions. Wear protective gloves if necessary.

- Parts
- Assembly
- Safety Rules
- Use and Care
- Troubleshooting

Assembly Questions?  
Call 1-800-4-MY-HOME®

Parts Ordering:  
Call 1-800-366-PART (7278)

To Installer/Assembler: Leave these instructions with consumer.

To Consumer: Keep this manual for future reference.



 **WARNING** 

**FOR YOUR SAFETY**

1. Do not store or use gasoline or other flammable vapors and liquids in the vicinity of this or any other appliance.
2. An LP tank not connected for use shall not be stored in the vicinity of this or any other appliance.

**FOR YOUR SAFETY**

If you smell gas:

1. Shut off gas to the appliance.
2. Extinguish any open flame.
3. Open lid.
4. If odor continues, immediately call your gas supplier or your fire department.

**Call Grill Service Center For Help And Parts**

If you have questions or need assistance during assembly, please call **1-800-241-7548**. You will be speaking to a representative of the grill manufacturer and not a Sears employee. To order new parts call Sears at **1-800-4-MY-HOME®**.

**Product Record**

**IMPORTANT:** Fill out the product record information below.

Model Number \_\_\_\_\_

Serial Number \_\_\_\_\_  
See rating label on grill for serial number.

Date Purchased \_\_\_\_\_

 **CAUTION** 

For residential use only. Do not use for commercial cooking.

 **WARNING** 

**CARBON MONOXIDE HAZARD**

Burning charcoal releases carbon monoxide which has no odor and can cause serious injury or death. Never burn charcoal inside homes, vehicles or tents.

**Safety Symbols**

The symbols and boxes shown below explain what each heading means. Read and follow all of the messages found throughout the manual.

 **DANGER** 

**DANGER:** Indicates an imminently hazardous situation which, if not avoided, will result in death or serious injury.

 **WARNING** 

**WARNING:** Be alert to the possibility of serious bodily injury if the instructions are not followed. Be sure to read and carefully follow all of the messages.

 **CAUTION** 

**CAUTION:** Indicates a potentially hazardous situation which, if not avoided, may result in minor or moderate injury.

**Installation Safety Precautions**

- Use grill only with LP (propane) gas and the regulator/valve assembly supplied.
- Grill installation must conform with local codes, or in their absence with **National Fuel Gas Code, NFPA 54 / ANSI Z223.1**. Handling and storage of LP cylinders must conform to LP Gas Code **NFPA/ANSI 58**. Grill is not for use in or on recreational vehicles and/or boats.
- All electrical accessories (such as rotisserie) must be electrically grounded in accordance with local codes, or **National Electrical Code, ANSI / NFPA 70**. Keep any electrical cords and/or fuel supply hoses away from any hot surfaces.
- This grill is safety certified for use in the United States only. Do not modify for use in any other location. Modification will result in a safety hazard.

## TABLE OF CONTENTS

For Your Safety .....	2
Grill Service Center .....	2
Product Record Information .....	2
Safety Symbols .....	2
Installation Safety Precautions .....	2
Kenmore Grill Warranty .....	3
Parts List .....	4
Parts Diagram .....	5
Assembly .....	6-15
Use and Care .....	16-25
Cooking Chart .....	24
Troubleshooting .....	25

### Repair Protection Agreements

*Congratulations on making a smart purchase.* Your new Kenmore® product is designed and manufactured for years of dependable operation. But like all products, it may require repair from time to time. That's when having a Repair Protection Agreement can save you money and aggravation.

*Purchase a Repair Protection Agreement now and protect yourself from unexpected hassle and expense.*

Here's what's included in the Agreement:

- ✓ **Expert service** by our 12,000 professional repair specialists
- ✓ **Unlimited service and no charge** for parts and labor on all covered repairs
- ✓ **Product replacement** if your covered product can't be fixed
- ✓ **Discount of 10%** from regular price of service and service-related parts not covered by the agreement; also, 10% off regular price of preventive maintenance check
- ✓ **Fast help by phone** – phone support from a Sears technician on products requiring in-home repair, plus convenient repair scheduling

Once you purchase the Agreement, a simple phone call is all that it takes for you to schedule service. You can call anytime day or night, or schedule a service appointment online.

Sears has over 12,000 professional repair specialists, who have access to over 4.5 million quality parts and accessories. That's the kind of professionalism you can count on to help prolong the life of your new purchase for years to come. Purchase your Repair Protection Agreement today!

**Some limitations and exclusions apply.**

**For prices and additional information call 1-800-827-6655.**

### Sears Installation Service

*For Sears professional installation of home appliances, garage door openers, water heaters, and other major home items, in the U.S.A. call 1-800-4-MY-HOME®*

## WARRANTY

### KENMORE GRILL WARRANTY

#### Full 1-Year Warranty on Grill

For one year from the date of purchase Sears will repair or replace, at our option, any grill part (except for paint finish) that is defective in material or workmanship.

#### Limited Warranty on Selected Grill Parts

From one year after the date of purchase for the designated time periods listed below, Sears will replace the following grill parts if they are defective in material or workmanship. You will be charged for labor.

- Lifetime of Grill: Aluminum Top and Bottom Castings (except for paint finish)
- 2 years: Burner Assembly

### WARRANTY SERVICE

Warranty service is available by contacting Sears at **1-800-4-MY-HOME®**.

### WARRANTY RESTRICTIONS

This warranty is void if grill is used for commercial or rental purposes.

This warranty applies only when the grill is used in the United States.

This warranty gives you specific legal rights, and you may also have other rights which vary from state to state.

Sears, Roebuck and Co., Dept. 817WA,  
Hoffman Estates, IL 60179

**PARTS LIST – Model No. 415.162120**

<u>Key</u>	<u>Qty</u>	<u>Description</u>	<u>Part #</u>	<u>Key</u>	<u>Qty</u>	<u>Description</u>	<u>Part #</u>	
1	2	Leg Assembly	4503239	27	1	Front Panel	4502456	
2	1	Base	4502429	28	1	Front Panel Shelf	4154518	
3	11	#10-24x2" Carriage Bolt	4080064	29	4	Push-Fastener	4080679	
4	12	#10-24 Plastic Tee Knob	4080091	30	1	Panel Wire	4151040	
5	1	Midshelf	4151034	31	4	End Cap	4080065	
6	2	Wheel Assembly	4310002	32	1	Side Shelf	4154372	
7	4	1" Hitch Pin	4080062	STD624001	33	5	#10-12x1-7/8" Wing Screw	4080096
8	2	Leg Extender	4154577	34	1	Tool Holder	4154376	
9	1	Grill Bottom	4580538	35	1	Sideburner Body	4526185	
10	1	Burner Assembly	4500074	36	1	Sideburner Frame	4501705	
11	1	Collector Box	4500278	37	4	#10-24 Wing Nut	4080063	STD541610
12	1	Electrode	5156119	38	1	Sideburner	5068026	
13	1	#10-16x1/2" Self-Tap Screw	4080059	STD611005	39	1	Sideburner Knob	4154471
14	1	Control Panel	4526143	40	1	Sideburner Grate	4156376	
15	1	Valve/Hose/Regulator Assembly	4524195	41	1	Grill Lid	4580596	
16	2	Valve Clip	4151043	42	2	1/4x1-1/8" Hinge Pin	4156513	
17	4	#10x1/2", T-20, Self-Tap Screw	4080043	43	1	Handle	4154473	
18	1	Ignitor	5156113	44	2	#10-24x1" Machine Screw	4080302	STD511010
19	1	Ignitor Wire	4153196	45	1	Temperature Gauge Bezel	4157169	
20	1	Sideburner Ignitor Wire	5156109	46	1	Temperature Gauge with Wing Nut	4157171	
21	2	1/4-20x1-1/4" Carriage Bolt	4080615	STD532512	47	1	Logo Plate	4156081
22	2	1/4-20 Wing Nut	4080221	STD541625	48	2	3/16" Flat Nut	4153096
23	2	#10-24x1-1/4" Carriage Bolt	4080074	49	1	SwingAway	4152124	
24	1	Tank Wire	4151019	50	1	Cooking Grate	4152739	
25	1	V-bar	4500326	51	1	Grease Clip	5156607	
26	2	Control Knob	4154559					



**PARTS DIAGRAM – Model No. 415.162120**

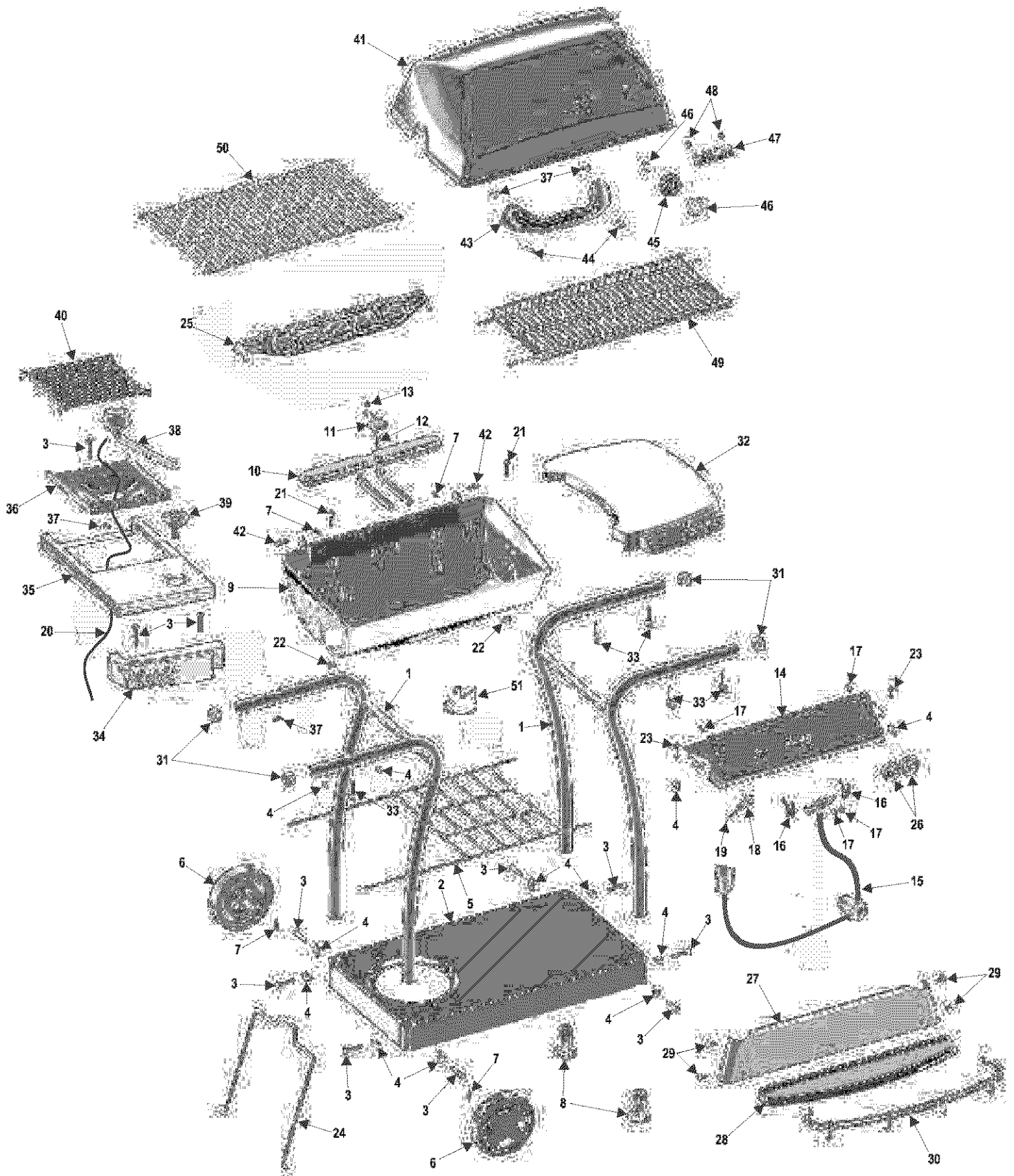

1

**Cart Assembly Step 1**

- Position base on edge with tank hole to left side.
- Insert legs into base and attach with carriage bolts and plastic wing nuts. Use top holes on left side. **DO NOT FULLY TIGHTEN.**
- Insert midshelf wire into holes on insides of legs, long wires toward left side. Fully tighten carriage bolts and plastic wing nuts.

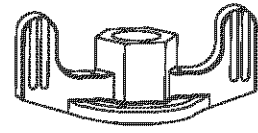

4  
Qty. 8

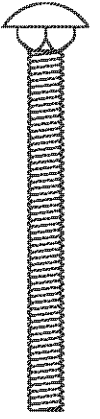

3  
Qty. 8

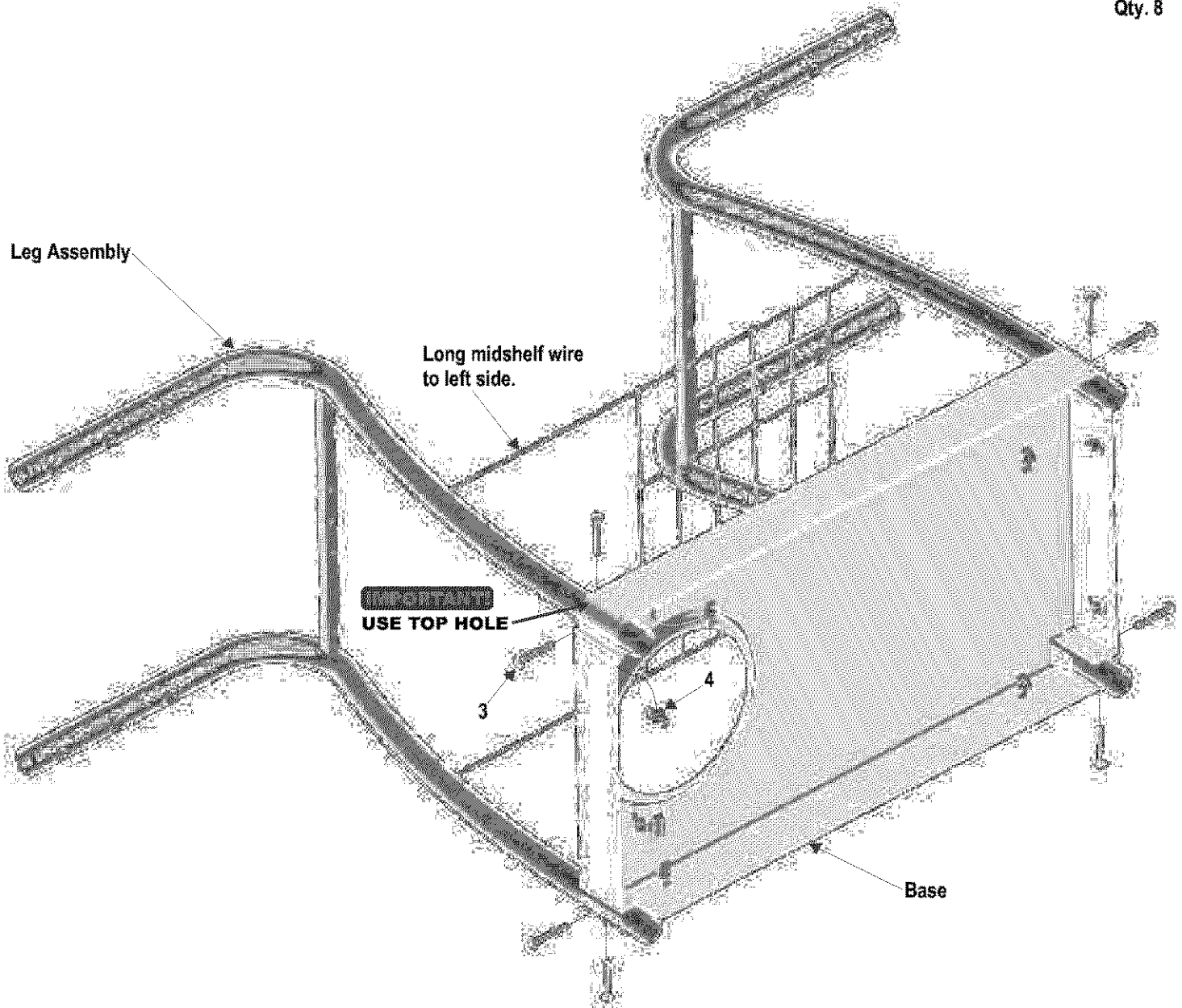

# 2

## Cart Assembly Step 2

- Insert wheel/hubcap assemblies into bottom holes on left legs.
- Secure beneath base with hitch pins. See inset below.
- Push leg extenders into right legs.

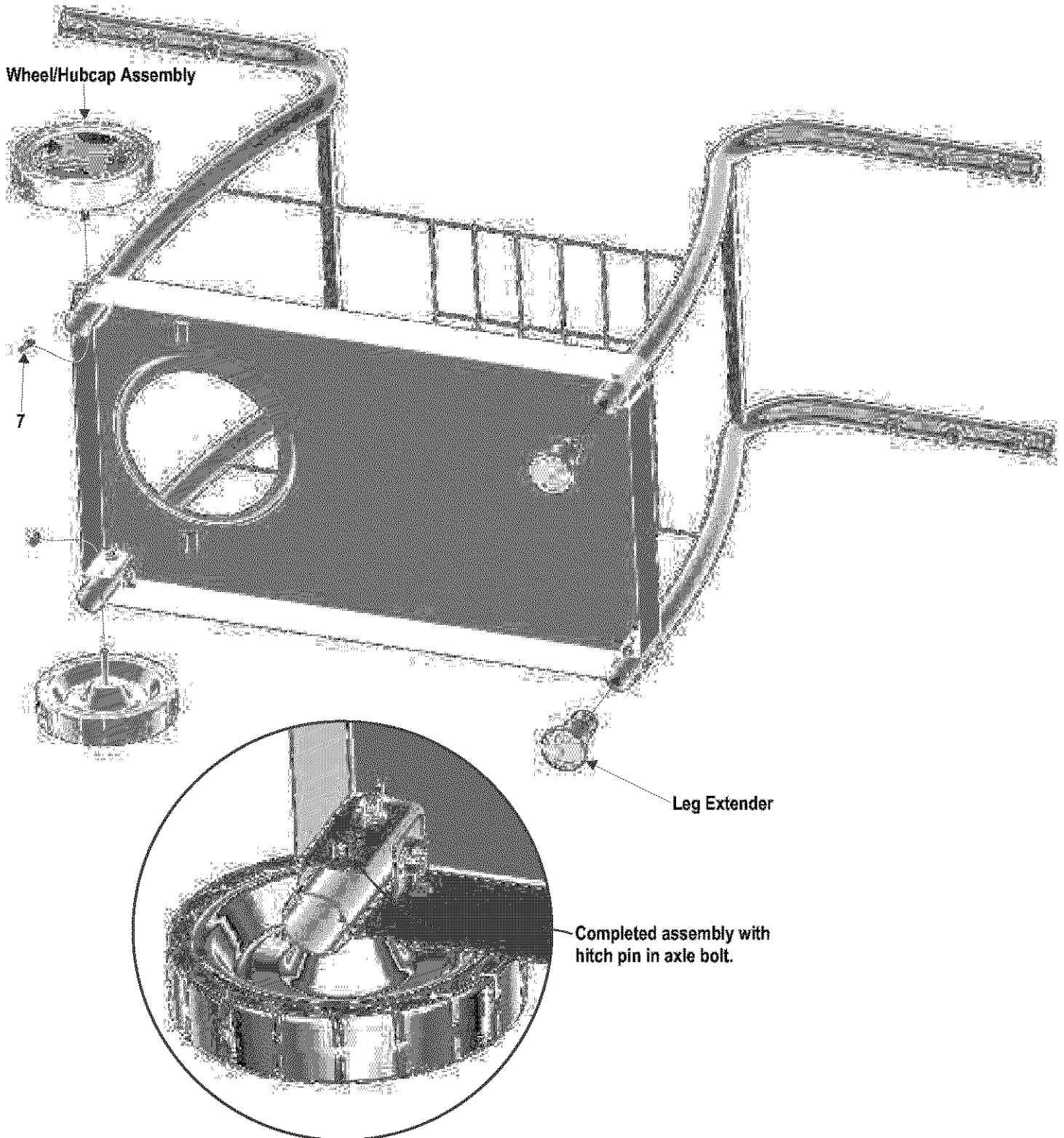
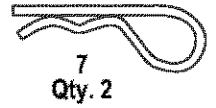

3

### Grill Bottom/Control Panel Assembly And Tank Wire

- Carefully place grill bottom/control panel assembly onto cart, so as not to scratch paint on legs. Make sure control panel bracket fits over support bar on each side.
- Insert carriage bolts through grill bottom and center hole in support bar. Thread metal wing nuts onto bolts but do not fully tighten.
- Insert carriage bolts through control panel bracket and front holes in support bar. Secure with plastic wing nuts.
- Fully tighten metal wing nuts.
- Insert ends of tank wire into slots on each side of tank hole in grill base. Lean tank wire toward midshelf.

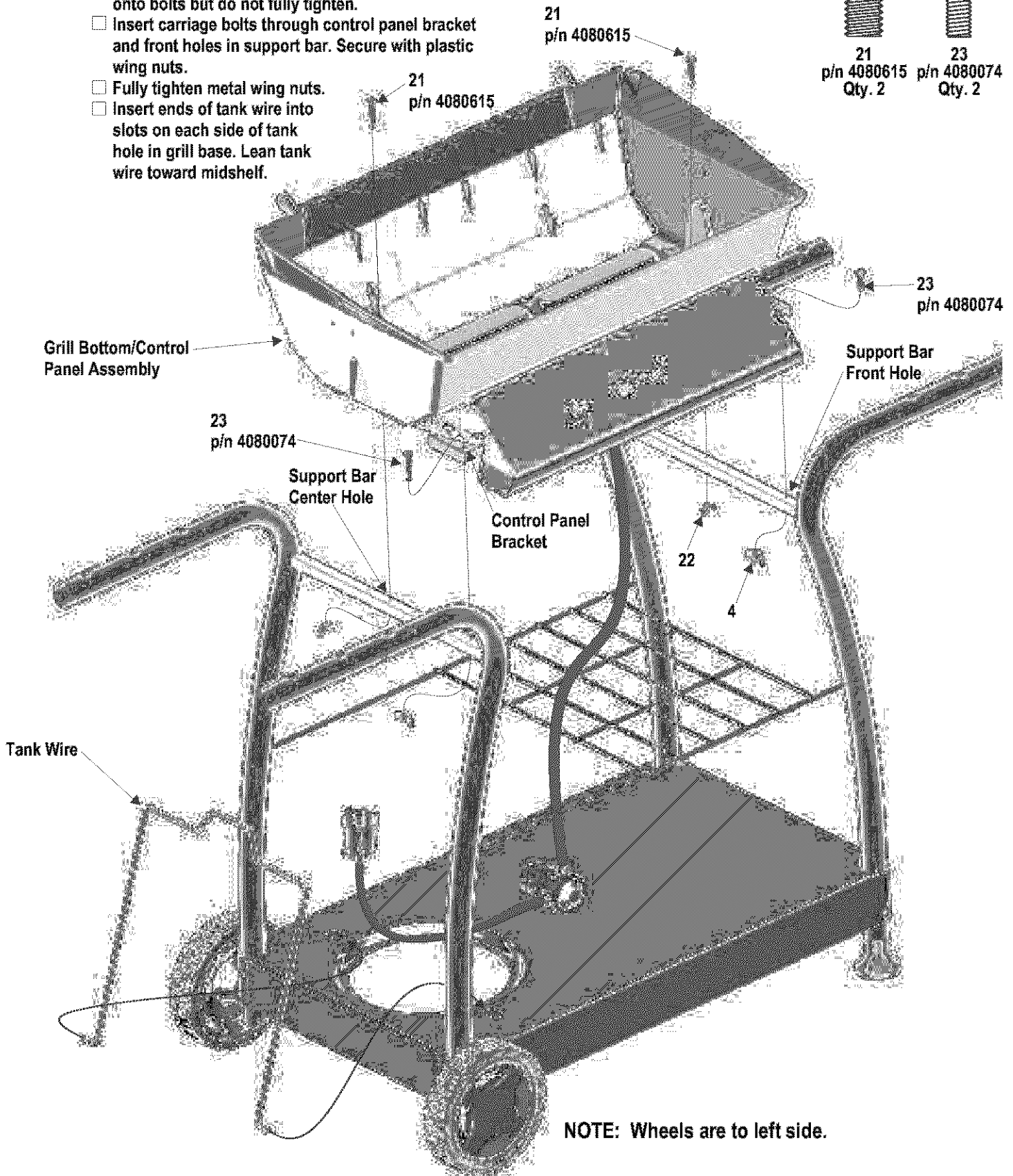
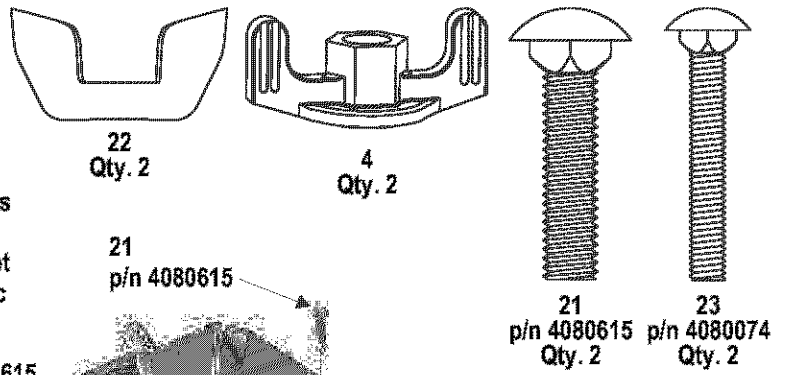

4

**V-bar and Control Knob Assembly**

- Rest V-bar on bar supports at each end of grill bottom.
- Press control knobs onto valve stems.

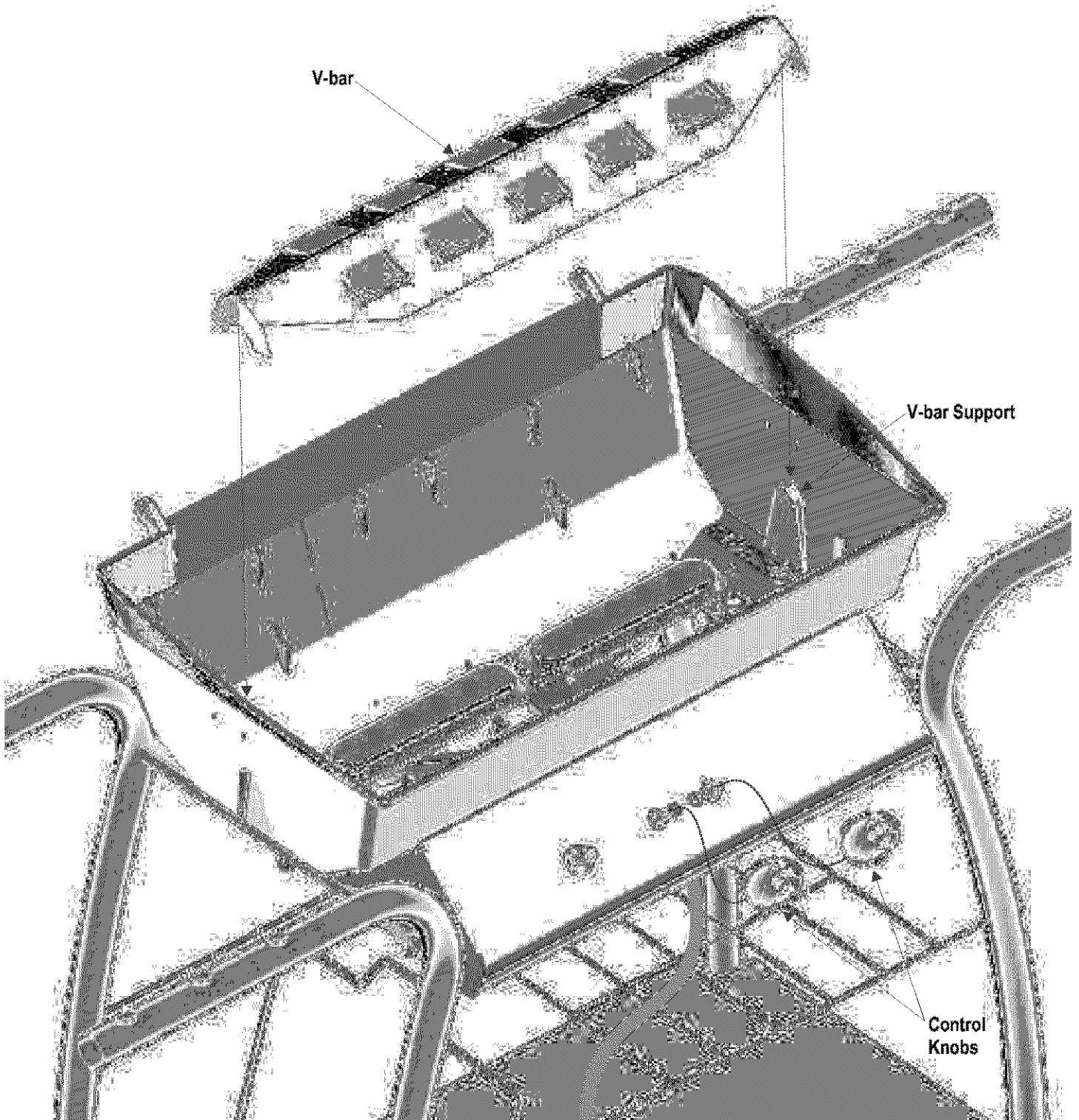

5

### Front Panel, Shelf And Panel Wire Assembly

- Snap shelf into front panel. Make sure that shelf rests on top of front panel shelf support tab.
- Hook outer wires on panel wire into holes in panel, rotate panel wire down, and insert remaining wires into holes in front of shelf.
- Slide top edge of front panel UNDER control panel.
- Secure panel to legs with push-fasteners.

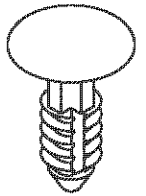

29  
Qty. 4

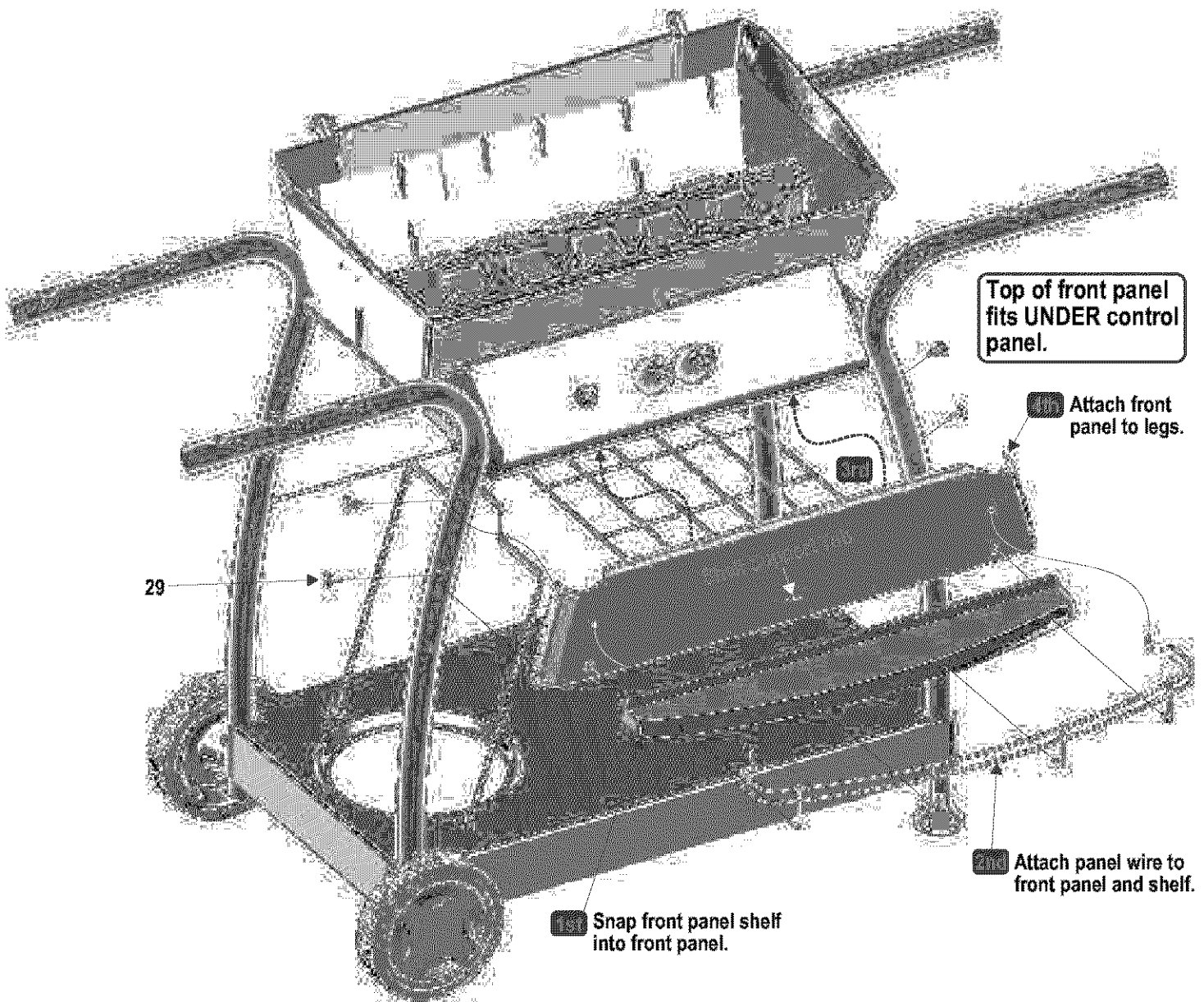

# 6

## End Cap, Side Shelf, And Tool Holder Assembly

- Insert end caps into ends of leg tubes.
- Position side shelf onto right legs as shown below and secure with four wing screws.
- Position tool holder onto left front leg and secure with two carriage bolts and plastic wing nuts. Use the two outer holes. Do not use the middle hole.

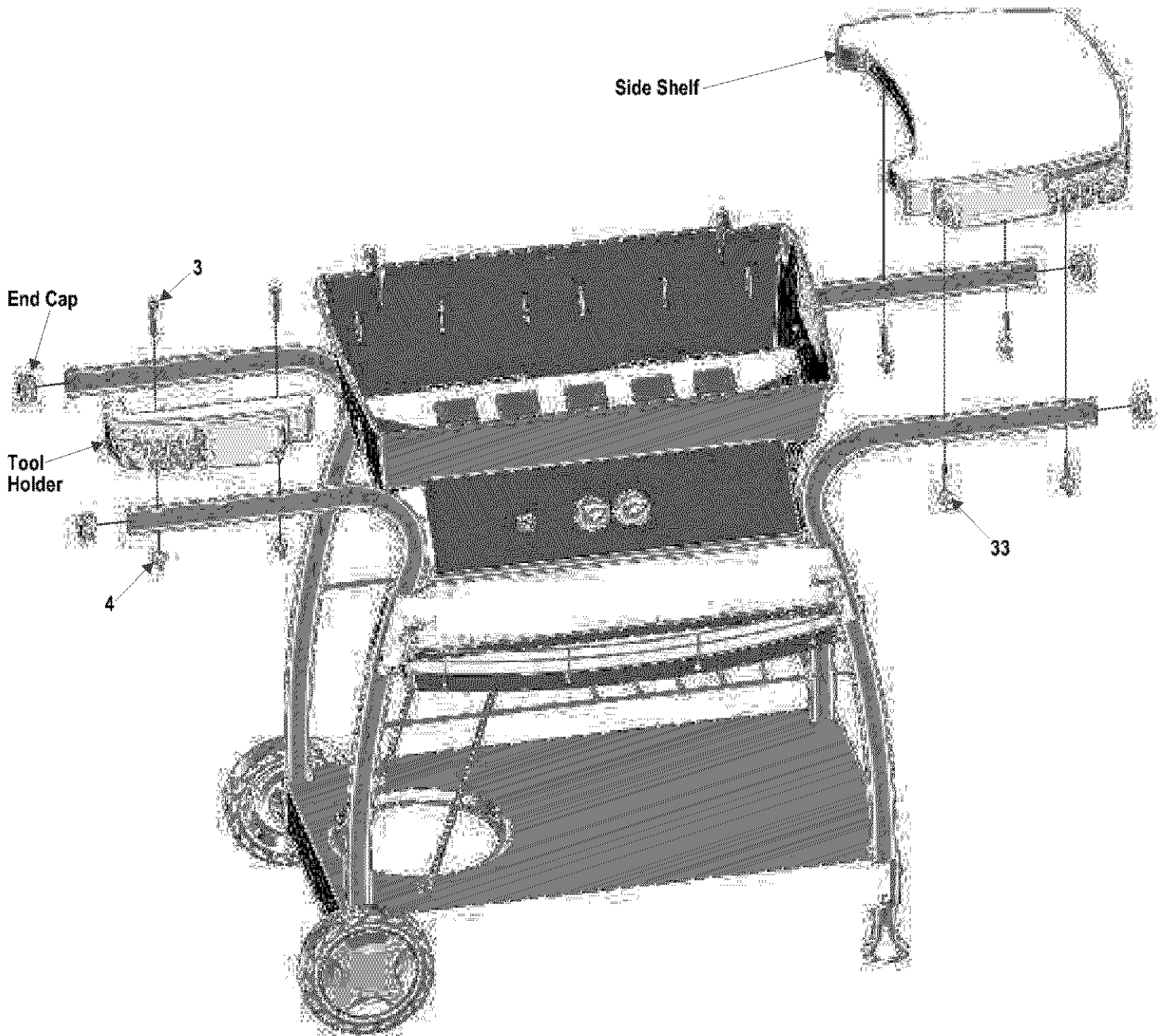
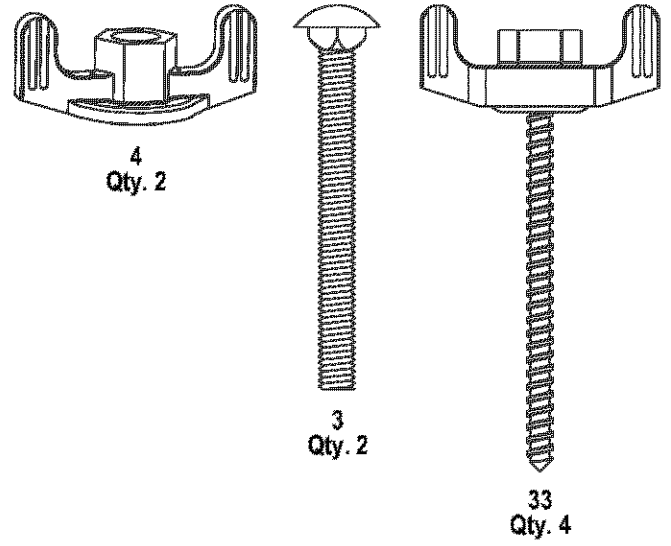

# 7

## Sideburner Assembly

- Place sideburner body onto legs. Secure at front with one wing screw through leg, tool holder, and into body.
- Insert tab on sideburner frame into hole in body. At rear leg, insert carriage bolt through frame, body, and middle leg hole. Secure with metal wing nut.
- Insert sideburner tube into large frame hole. Insert burner's threaded stud into small frame hole. Attach metal wing nut to stud, but do not fully tighten.
- Insert sideburner valve into burner tube and snap valve cup into body. Note proper tube-to-valve engagement in figure A. Once proper engagement is made, fully tighten metal wing nut beneath burner.
- Attach sideburner igniter wire (long wire behind control panel) to electrode beneath sideburner. See figure B.
- Press sideburner knob firmly onto sideburner valve and place sideburner grate onto body.

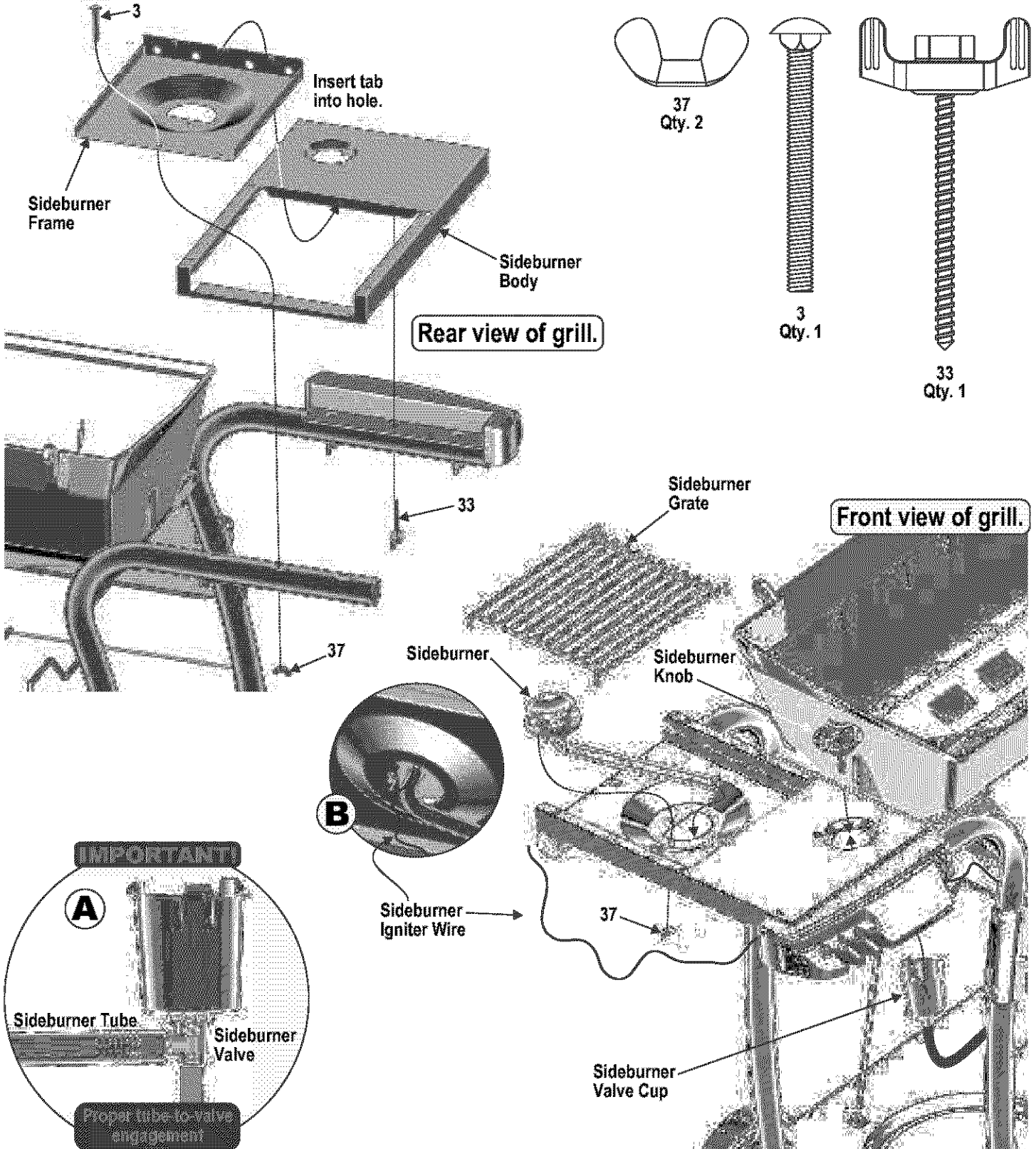

# 8

## Grill Lid, Handle, Temperature Gauge and Logo Plate Assembly

- Attach grill lid to grill bottom with hinge pins and hitch pins.
- Attach handle to lid with machine screws and metal wing nuts.
- Remove wing nut from temperature gauge, insert gauge into bezel, then into hole in grill lid. Secure with wing nut.

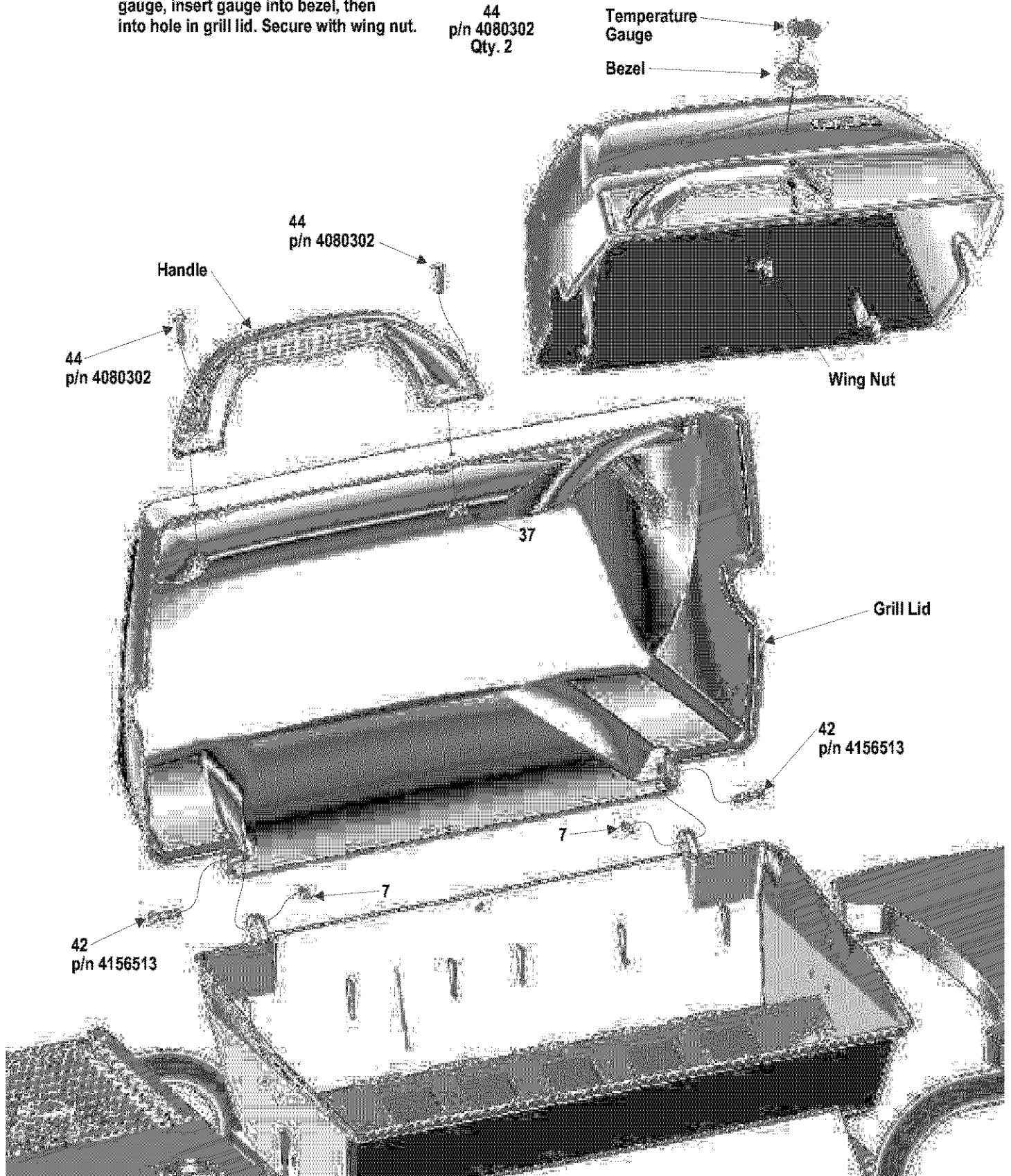
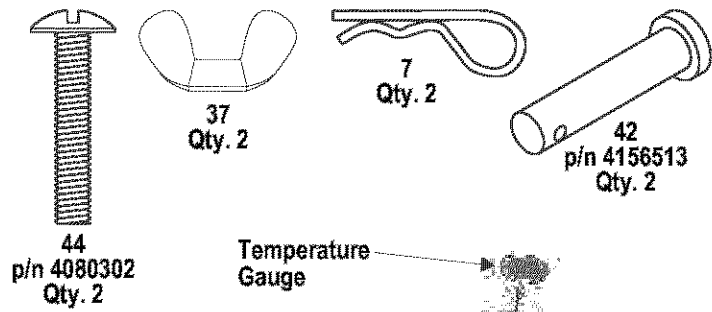

# 9

## SwingAway And Cooking Grate Assembly

- Insert SwingAway pivot wires into holes in side of grill lid.
- Insert SwingAway leg wires into top holes in side of grill bottom.
- Place cooking grate onto grate rests in grill bottom.

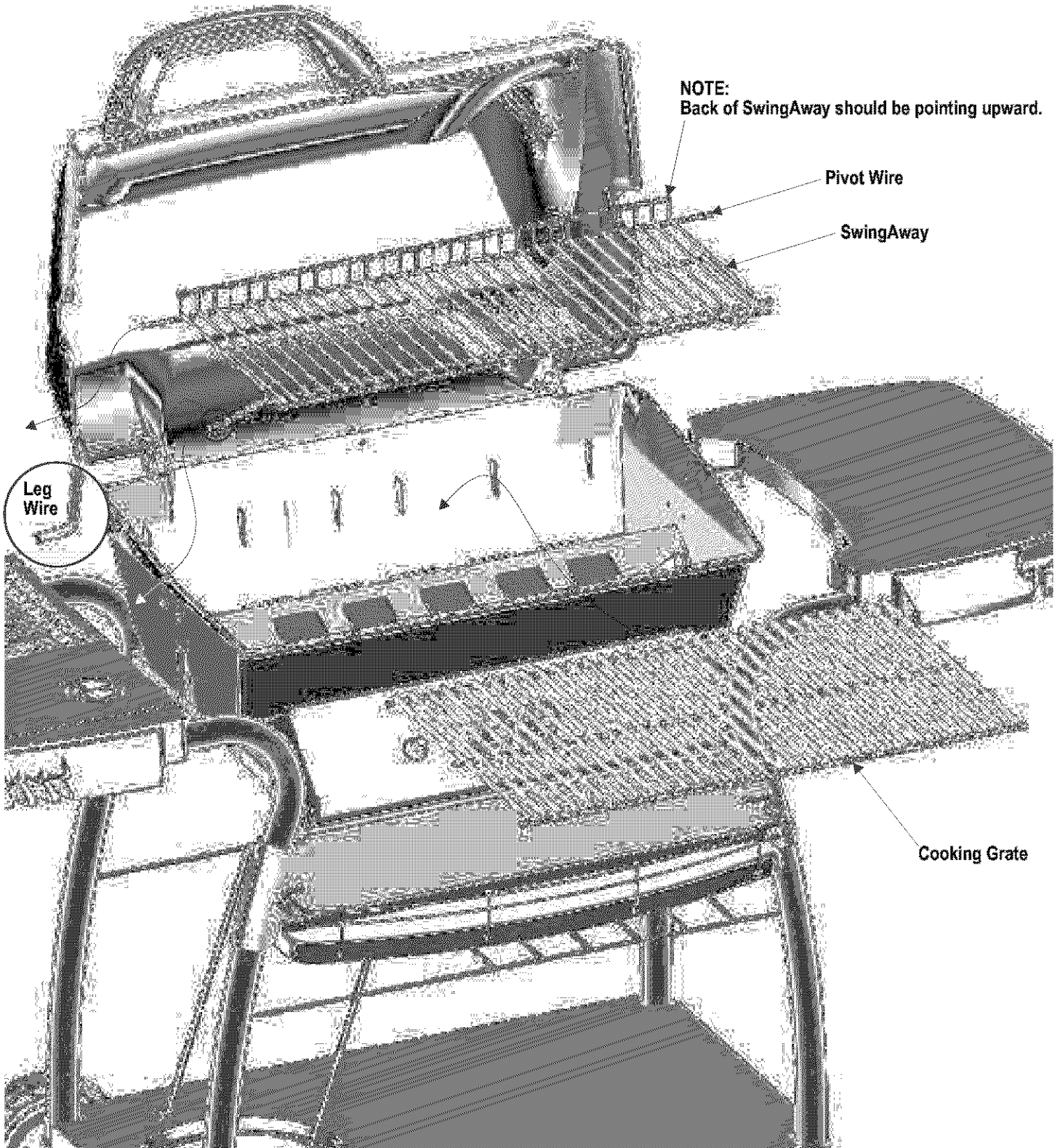

**NOTE:**  
Back of SwingAway should be pointing upward.

Pivot Wire

SwingAway

Leg Wire

Cooking Grate

# 10

## Tank Wire, LP Tank And Grease Clip Assembly

- ❑ Place LP tank into hole in base with tank valve facing toward front of grill.
- ❑ To secure LP tank, pull tank wire over the side of the tank, toward the tank collar.
- ❑ See Use and Care section for connection of regulator to LP tank.
- ❑ Hang grease clip beneath grill bottom. See inset below. To collect grease, hang an empty soup can (not included) from grease clip.

▲ LP GAS TANK IS SOLD SEPARATELY. Fill and leak-check tank before attaching to grill and regulator. See Use and Care section for instructions.

### CAUTION

- Tank collar opening must face to front of cart once tank is attached.
- Failure to install tank correctly may allow gas hose to be damaged in operation, resulting in the risk of fire.

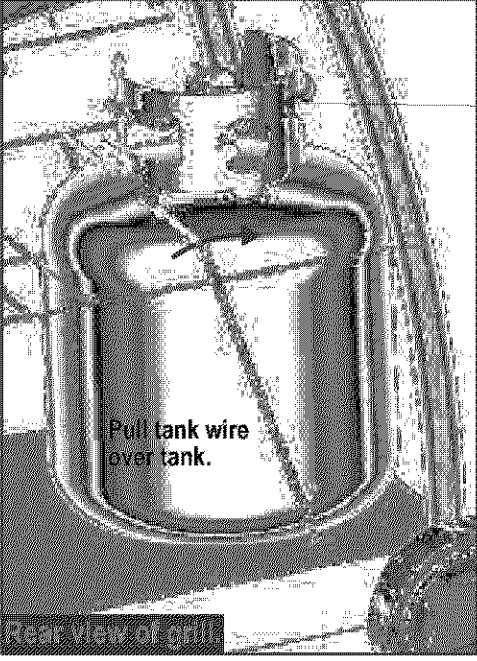

### CAUTION

Failure to install can in clip will cause hot grease to drip from bottom of grill with risk of fire or property damage.

See Use & Care section of this manual to perform the "Burner Flame Check" and for important safety instructions before using.

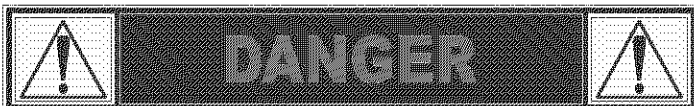

- **Never fill the cylinder beyond 80% full. An overfilled spare LP tank is hazardous due to possible gas released from the safety relief valve.**
- **The safety relief valve on the LP tank could activate releasing gas and cause an intense fire with risk of property damage, serious injury or death.**
- **NEVER store a spare LP tank under or near grill or in enclosed areas.**
- **If you see, smell or hear escaping gas, immediately get away from the LP tank/grill and call your fire department.**
- **All spare LP tanks must have safety caps installed on the LP tank outlet.**

### LP Tank Removal, Transport And Storage

- Turn OFF all control knobs and LP tank valve. Turn coupling nut counterclockwise by hand only - do not use tools to disconnect. Lift LP tank wire upward off of LP tank collar, then lift LP tank up and off of support bracket. Install safety cap onto LP tank valve. Always use cap and strap supplied with valve. **Failure to use safety cap as directed may result in serious personal injury and/or property damage.**

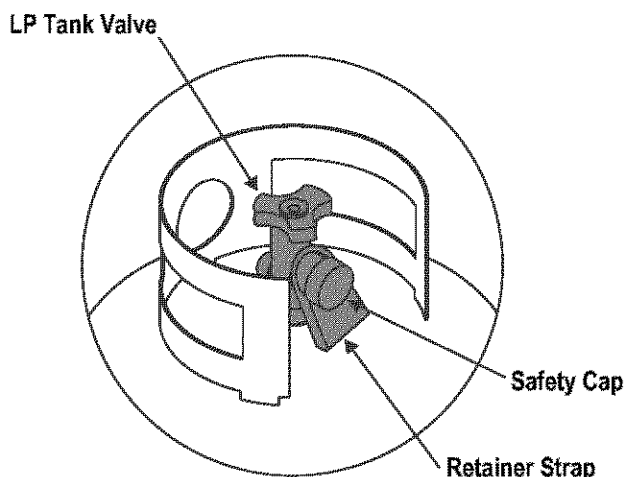

- A disconnected LP tank in storage or being transported must have a safety cap installed (as shown). Do not store an LP tank in enclosed spaces such as a carport, garage, porch, covered patio or other building. Never leave an LP tank inside a vehicle which may become overheated by the sun.
- Do not store an LP tank in an area where children play.

### LP Tank

- **The LP tank used with your grill must meet the following requirements:**
- Use LP tanks only with these required measurements: 12" (30.5cm) (diameter) x 18" (45.7 cm) (tall) with 20 lb. (9 kg.) capacity maximum.
- LP tanks must be constructed and marked in accordance with specifications for LP tank of the U.S. Department of Transportation (DOT). See LP tank collar for marking.
- LP tank valve must have:
  - Type 1 outlet compatible with regulator or grill.
  - Safety relief valve.
  - UL listed Overfill Protection Device (OPD). This OPD safety feature is identified by a unique triangular hand wheel. **Use only LP tanks equipped with this type of valve.**
- LP tank must be arranged for vapor withdrawal and include collar to protect LP tank valve.

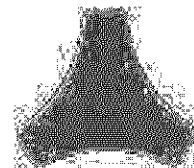

OPD Hand Wheel

### LP (Liquefied Petroleum Gas)

- LP gas is nontoxic, odorless and colorless when produced. **For Your Safety**, LP gas has been given an odor (similar to rotten cabbage) so that it can be smelled.
- LP gas is highly flammable and may ignite unexpectedly when mixed with air.

### LP Tank Filling

- Use only licensed and experienced dealers.
- LP dealer **must purge tank** before filling.
- Dealer should **NEVER** fill LP tank more than 80% of LP tank volume. Volume of propane in tank will vary by temperature.
- A frosty regulator indicates gas overfill. Immediately close LP tank valve and call local LP gas dealer for assistance.
- Do not release liquid propane (LP) gas into the atmosphere. This is a hazardous practice.
- To remove gas from LP tank, contact an LP dealer or call a local fire department for assistance. Check the telephone directory under "Gas Companies" for nearest certified LP dealers.

## LP Tank Exchange

- Many retailers that sell grills offer you the option of replacing your empty LP tank through an exchange service. Use only those reputable exchange companies that inspect, precision fill, test and certify their cylinders. **Exchange your tank only for an OPD safety feature-equipped tank as described in the "LP Tank" section of this manual.**
- Always keep new and exchanged LP tanks in upright position during use, transit or storage.
- **Leak test new and exchanged LP tanks BEFORE connecting to grill.**

## LP Tank Leak Test

### For your safety

- Leak test must be repeated each time LP tank is exchanged or refilled.
- Do not smoke during leak test.
- Do not use an open flame to check for gas leaks.
- Grill must be leak tested outdoors in a well-ventilated area, away from ignition sources such as gas fired or electrical appliances. During leak test, keep grill away from open flames or sparks.
- Use a clean paintbrush and a 50/50 mild soap and water solution. Brush soapy solution onto areas indicated by arrows in figure below.



WARNING



If "growing" bubbles appear do not use or move the LP tank. Contact an LP gas supplier or your fire department!

- ▲ **Do not use household cleaning agents.** Damage to gas train components can result.

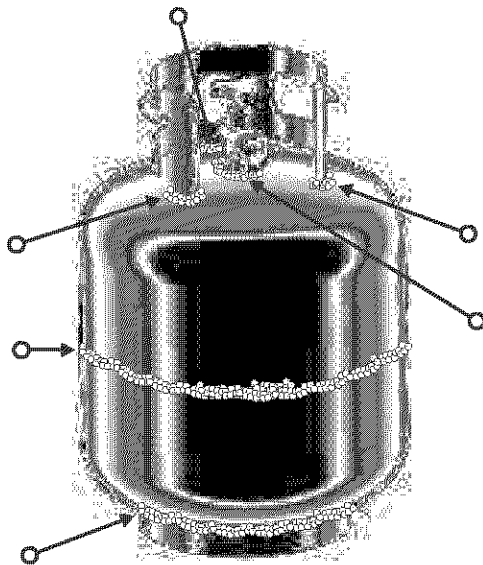

## Connecting Regulator To The LP Tank

1. LP tank must be properly secured onto grill. (Refer to assembly section.)
2. Turn all control knobs to the OFF position.
3. Turn LP tank OFF by turning OPD hand wheel clockwise to a full stop.
4. Remove the protective cap from LP tank valve. Always use cap and strap supplied with valve.

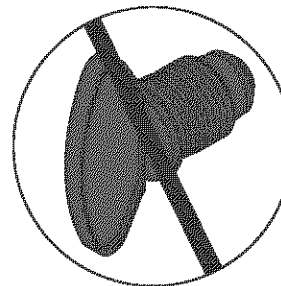
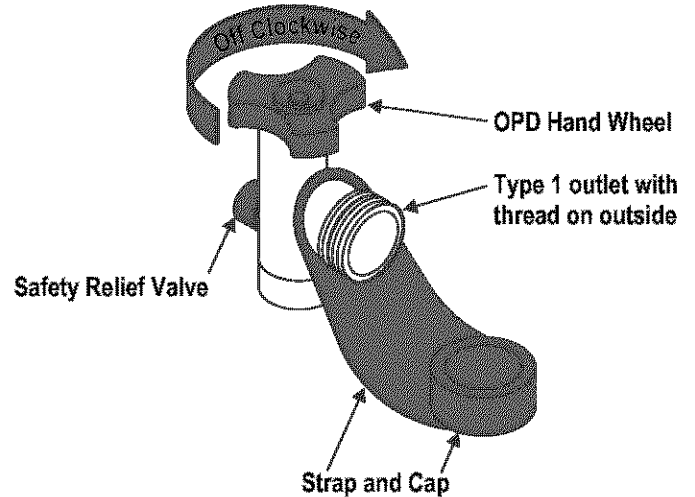

**Do not use a POL transport plug (plastic part with external threads)! It will defeat the safety feature of the valve.**

5. Hold regulator and insert nipple into LP tank valve. Hand-tighten the coupling nut, holding regulator in a straight line with LP tank valve so as not to cross-thread the connection.

**Nipple has to be centered into the LP tank valve.**

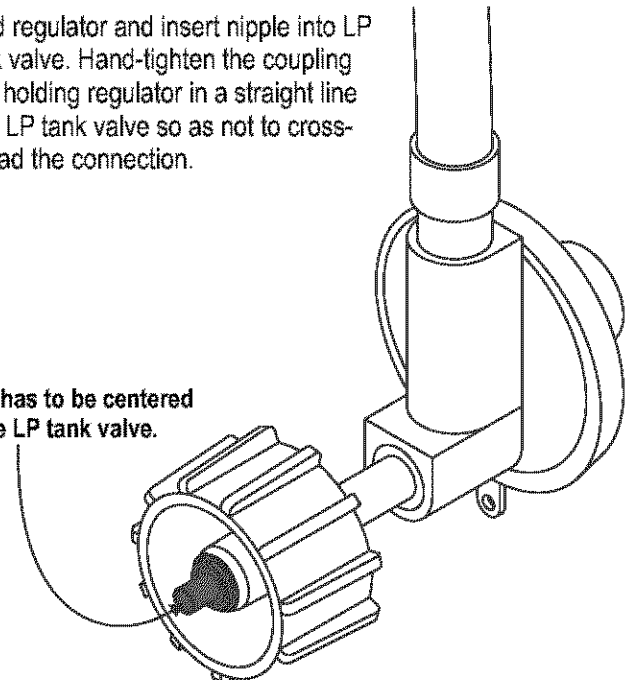

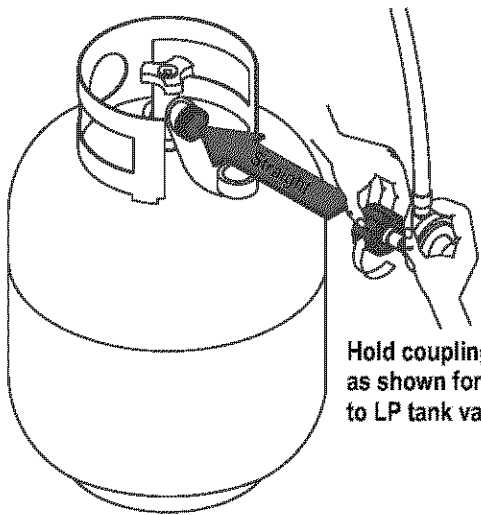

Hold coupling nut and regulator as shown for proper connection to LP tank valve.

6. Turn the coupling nut clockwise and tighten to a full stop. The regulator will seal on the back-check feature in the LP tank valve, resulting in some resistance. **An additional one-half to three-quarters turn is required to complete the connection. Tighten by hand only – do not use tools.**

**NOTE:**

If you cannot complete the connection, disconnect regulator and repeat steps 5 and 6. If you are still unable to complete the connection, **do not use this regulator!**

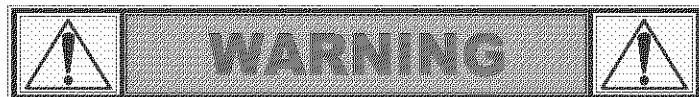

- Do not insert any foreign objects into the valve outlet. You may damage the valve and cause a leak. Leaking propane may result in explosion, fire, severe personal injury, or death.
- Never attempt to attach this grill to the self-contained LP gas system of a camper trailer or motor home.
- Do not use grill until leak-tested.
- If a leak is detected at any time, STOP and call the fire department.
- If you cannot stop a gas leak, *immediately* close LP tank valve and call LP gas supplier or your fire department!

**Leak Testing Valves, Hose and Regulator**

1. Turn all grill control knobs to OFF.
2. Be sure regulator is tightly connected to LP tank.
3. Completely open LP tank valve by turning OPD hand wheel counterclockwise. If you hear a *rushing sound*, turn gas off immediately. There is a major leak at the connection. **Correct before proceeding.**
4. Brush soapy solution onto areas where bubbles are shown in picture below:

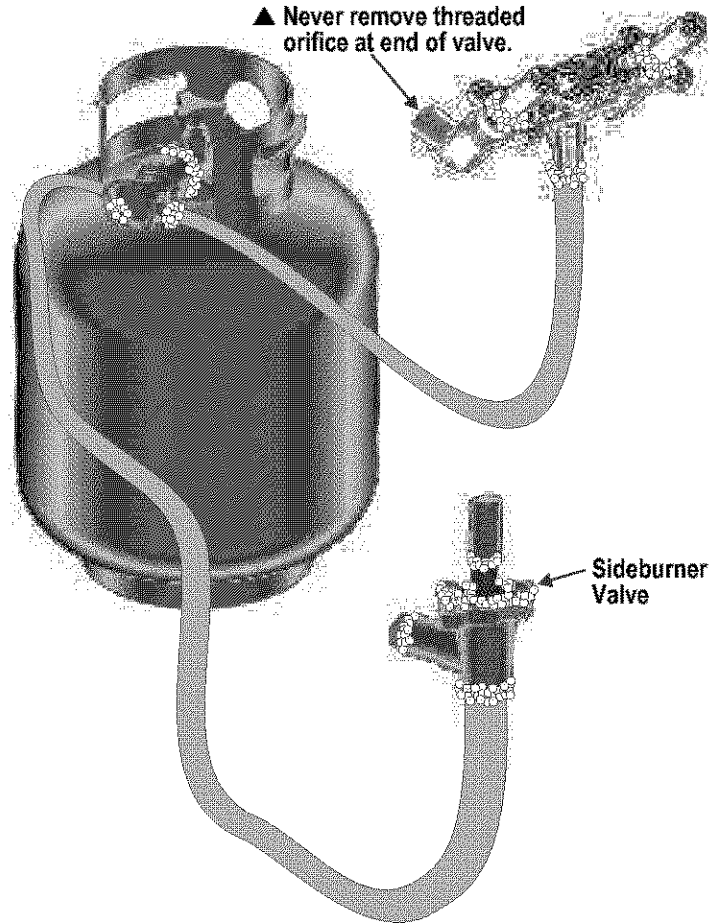

5. If “growing” bubbles appear, there is a leak. Close LP tank valve immediately and retighten connections. **If leaks cannot be stopped do not try to repair.** Call Sears for replacement parts at **1-800-4-MY-HOME®**.
6. Always close LP tank valve after performing leak test by turning hand wheel clockwise.





## WARNING

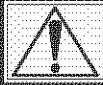

### For Safe Use Of Your Grill And To Avoid Serious Injury:

- Do not let children operate or play near grill.
- Keep grill area clear and free from materials that burn.
- Do not block holes in bottom or back of grill.
- Check burner flames regularly.
- Use grill only in well-ventilated space. NEVER use in enclosed space such as carport, garage, porch, covered patio, or under an overhead structure of any kind.
- Do not use charcoal or ceramic briquets in a gas grill. *(Unless briquets are supplied with your grill.)*
- **Use grill at least 3 ft. from any wall or surface.** Maintain 10 ft. clearance to objects that can catch fire or sources of ignition such as pilot lights on water heaters, live electrical appliances, etc.

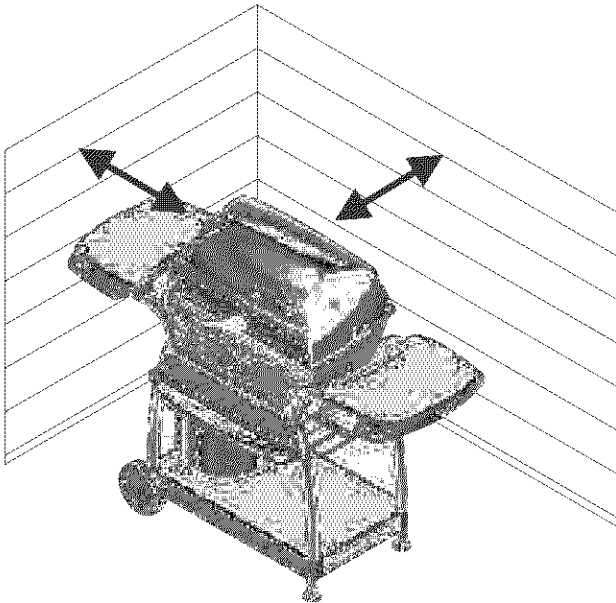

#### • Apartment Dwellers:

Check with management to learn the requirements and fire codes for using an LP gas grill in your apartment complex. If allowed, use outside on the ground floor with a three (3) foot clearance from walls or rails. Do not use on or under balconies.

- **NEVER attempt to light burner with lid closed. A buildup of non-ignited gas inside a closed grill is hazardous.**
- **Never operate grill with LP tank out of correct position specified in assembly instructions.**
- **Always close LP tank valve and remove coupling nut before moving LP tank from specified operation position.**

### Safety Tips

- ▲ Before opening LP tank valve, check the coupling nut for tightness.
- ▲ When grill is not in use, turn off all control knobs and LP tank valve.
- ▲ Never move grill while in operation or still hot.
- ▲ Use long-handled barbecue utensils and oven mitts to avoid burns and splatters.
- ▲ Maximum load for shelves is 10 lbs.
- ▲ A soup can **must** be attached to grease clip and emptied after each use. Do not remove soup can until grill has completely cooled.
- ▲ If you notice grease or other hot material dripping from grill onto valve, hose or regulator, turn off gas supply at once. Determine the cause, correct it, then clean and inspect valve, hose and regulator before continuing. Perform a leak test.
- ▲ The regulator may make a humming or whistling noise during operation. This will not affect safety or use of grill.
- ▲ If you have a grill problem see the "Troubleshooting Section".

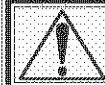

## WARNING

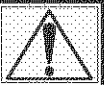

**If the regulator frosts, turn off grill and LP tank valve immediately. This indicates a problem with the tank and it should not be used on any product. Return to supplier!**



## CAUTION

- Putting out grease fires by closing the lid is not possible. Grills are well ventilated for safety reasons.
- Do not use water on a grease fire. Personal injury may result. If a grease fire develops, turn knobs and LP tank off.
- Do not leave grill unattended while preheating or burning off food residue on high. If grill has not been regularly cleaned, a grease fire can occur that may damage the product.

### Ignitor Lighting

▲ Do not lean over grill while lighting.

1. **Open lid.** Turn on gas at LP tank.
2. Turn left knob to ● (ignite position).
3. Push ignitor button rapidly (up to 5 times) to light. Be sure burner lights and stays lit.
4. If burner does not light, turn knobs to OFF, wait 5 minutes, try again.
5. Once left burner is lit, turn right knob to ● to light right burner.
6. If ignitor does not work, wait 5 minutes, then follow match lighting instructions.

**After Lighting:** Turn knobs to **HI** position for warm-up. Do not warm up grill with knobs on ● (ignite position). Knobs and handle will become uncomfortably hot if left in ● (ignite position).

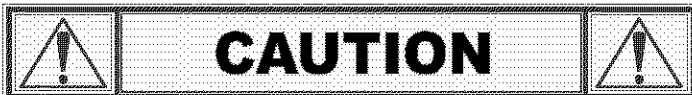

If burner does not light, turn knobs to OFF, wait 5 minutes, and try again. If the burner does not ignite with the valve open, gas will continue to flow out of the burner and could accidentally ignite with risk of injury.

### Match-Lighting

▲ Do not lean over grill while lighting.

1. **Open lid.** Turn on gas at LP tank.
2. Place lit match into match-lighting hole from beneath grill bottom (as shown below).
3. Push in and turn right knob to ● (ignite position). Be sure burner lights and stays lit.
4. Light left burner by pushing left knob in and turning to ● (ignite position).

**After Lighting:** Turn knobs to **HI** for warm-up.

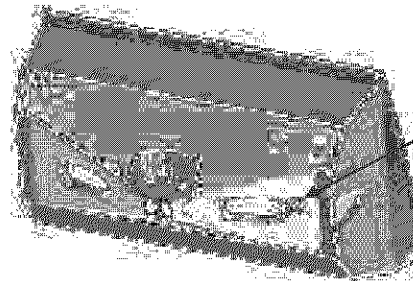

Match-lighting hole is beneath grill bottom.

### Ignitor Lighting The Sideburner

1. Turn on gas at LP tank.
2. Push in and turn sideburner knob to **HI**.
3. Press and hold ignitor button to light. Be sure burner lights and stays lit.
4. If burner does not light, turn sideburner knob to **OFF**, wait 5 minutes, try again.

### Match Lighting

1. Turn on gas at LP tank.
2. Hold a lit match to any port on the sideburner. Push in and turn the sideburner knob to **HI**. Be sure burner lights and stays lit.

## Before Your First Cookout

- Light burners, check to make sure they are lit, close the lid and warm up grill on HIGH for 15 minutes. Curing of paint and parts will produce an odor only on first lighting.

## Burner Flame Check

- Light burner, rotate knobs from HI to LO. You should see a smaller flame in LO position than seen on HI. Always check flame prior to each use. Perform flame check on sideburner. If only low flame is seen refer to "Sudden drop or low flame" in the *Troubleshooting Section*.

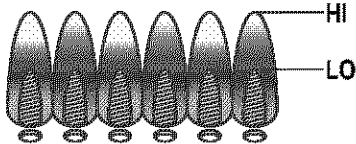



## Turning Grill Off

- Turn all knobs to  position. Turn LP tank off by turning OPD hand wheel clockwise to a full stop.

## Ignitor Check

- Turn gas off at LP tank. Press and hold ignitor button. "Click" should be heard and spark seen each time between collector box or burner and electrodes. See "Troubleshooting" if no click or spark.

## Valve Check

- **Important: Make sure gas is off at LP tank before checking valves.** Knobs lock in  position. To check valves, first push in knobs and release, knobs should spring back. If knobs do not spring back, replace valve assembly before using grill. Turn knobs to LO position then turn back to  position. Valves should turn smoothly.

## Hose Check

- Before each use, check to see if hoses are cut or worn. Replace damaged hoses before using grill. Use only identical Kenmore replacement valve/hose/regulator assembly.

## General Grill Cleaning

- Do not mistake brown or black accumulation of grease and smoke for paint. Interiors of gas grills are not painted at the factory (**and should never be painted**). Apply a strong solution of detergent and water or use a grill cleaner with scrub brush on insides of grill lid and bottom. Rinse and allow to completely air dry. **Do not apply a caustic grill/oven cleaner to painted surfaces.**
- **Plated wire grates:** Wash grates and V-bar with concentrated grill cleaner or use soap and water solution. Dry thoroughly and store indoors between cookouts.
- **Plastic parts:** Wash with warm soapy water and wipe dry.
  - ▲ Do not use citrisol, abrasive cleaners, degreasers or a concentrated grill cleaner on plastic parts. Damage to and failure of parts can result.
- **Porcelain grates:** Because of glass-like composition, most residue can be wiped away with baking soda/water solution or specially formulated cleaner. Use nonabrasive scouring powder for stubborn stains.

## Repainting Your Grill

- After extended use and exposure to weather, paint on grill may deteriorate or become spotted. Although this detracts from grill's appearance, it will not impair its performance.
- To refinish your grill brush outside of grill lid and bottom with wire brush and lightly sand with fine grit sandpaper. Sanding allows new paint to adhere more easily. Wash grill lid and bottom with soap and water to remove dust and grease. Do not use a grill cleaner on outside of grill. Wipe with vinegar. Refinish outside with heat-resistant paint. **Do not paint inside of grill.**

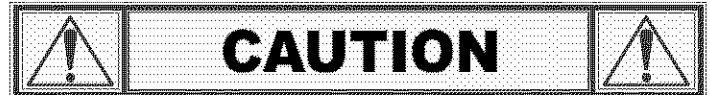

## NATURAL HAZARD • SPIDERS

**FACT:** Sometimes spiders and other small insects climb into the burner tubes attached to the burners. The spiders spin webs, build nests and lay eggs. The webs or nests can be very small, but they are very strong and can block the flow of gas. Clean burners prior to use after storing, at the beginning of grilling season or after a period of one month not being used.

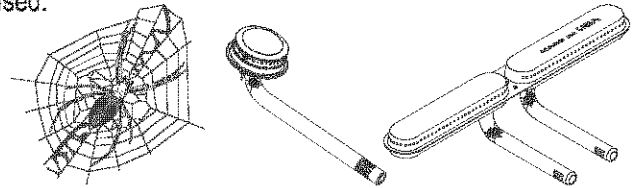

Typical spider webs inside burner.

Spider guards are on the air intakes in an effort to reduce this problem, but it will not eliminate it! An obstruction can result in a "flashback" (a fire in the burner tubes). The grill may still light, but the obstruction does not allow full gas flow to the burners.

### IF YOU EXPERIENCE THE FOLLOWING:

1. Smell gas.
2. Burner(s) will not light.
3. A small yellow flame from burner (should be blue).
4. Fire coming from around or behind control knob.

### STOP!

Immediately turn off gas at LP tank!

▲ After a burner tube fire, you must inspect the hose and do a "Leak Test" to assure no damage has occurred to the parts.

### SOLUTION:

Wait for grill to cool.

Follow the "Cleaning The Burner Assembly" instructions. Clean burners often. Use a 12" pipe cleaner to clean out the burner tubes. You may also force a stream of water from a hose nozzle through burner tubes to clean them.

## Cleaning The Burner Assembly

Follow these instructions to clean and/or replace parts of burner assembly or if you have trouble igniting grill.

1. Turn gas off at control knobs and LP tank.
2. Remove cooking grate and V-bar.
3. Remove grease can from beneath grill. Beneath grill bottom, disconnect ignitor wire from electrode.
4. Remove screw holding collector box. Note which hole on collector box used for attaching to burner. Remove collector box and clean ceramic portion of electrode with rubbing alcohol and cloth.
5. Under control panel, disengage burner springs from burner tubes. **Do not remove springs from valves.**
6. To remove burner, slide backwards, lift up and out of grill.
7. Clean outside of burner with soap and water. Lay burner upside down on flat surface. Force a stream of water through tubes. Make sure water comes out of all burner holes. Open clogged holes with a thin wire. **Shake out excess water** and examine holes. Due to normal wear and corrosion, some holes may become enlarged. If any large cracks or holes are found replace burner.
8. If grill is to be stored, coat burner lightly with cooking oil. Wrap in protective cover to keep insects out. If not storing grill after cleaning, hold burner at an angle and insert into grill bottom.
9. After cleaning, insert electrode into hole in grill bottom. Reattach collector box to burner with screw. **Be sure to use correct hole.**
10. Place end of spring into hole on underside of burner tube, as before, to secure burner. See figure A.

**VERY IMPORTANT: Burner tube must engage valve opening as shown in figure A.**

11. Reattach ignitor wire to electrode.
12. Reposition V-bar and cooking grate. Reattach clean can to grease clip.
13. Before cooking again on grill, follow "Burner Flame Check".

▲ **Do not use charcoal with this grill.**

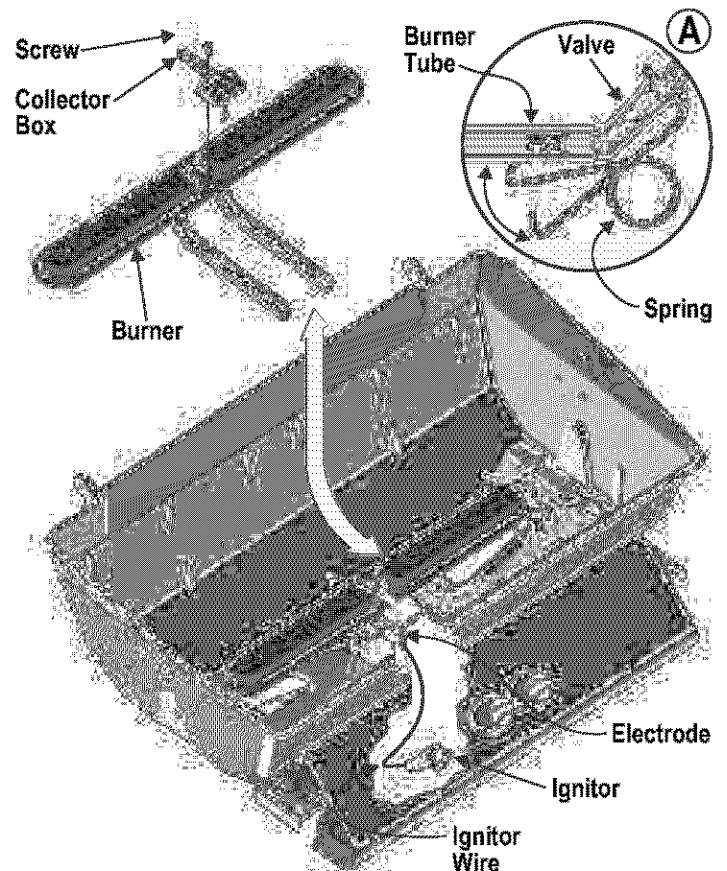

## Storing Your Grill

- Clean cooking grates.
- Store in dry location.
- When LP tank is connected to grill, store outdoors in well-ventilated space and out of reach of children.
- Cover grill if stored outdoors.
- Store grill indoors **ONLY** if LP tank is turned off and disconnected, removed from grill and stored outdoors.
- When removing grill from storage follow "Cleaning Burner Assembly" instructions before starting grill.

## Direct Cooking

Use both burners to heat the grill for searing of the meat. Once the meat has been seared, turn the burners to **LO** to cook meat thoroughly.

## Indirect Cooking

Once the grill is preheated, turn one of the burners off and place your meat on the grate above the burner that is **NOT** burning. This indirect method of cooking allows you to slow cook poultry or large cuts of meat without the touch of a direct flame.

- Always cook with the lid closed.
  - Due to weather conditions, cooking times may vary. During cold and windy conditions the temperature setting may need to be increased to insure sufficient cooking temperatures.
1. Ignite the **LEFT** burner. For slow cooking, adjust the control knob to the **LO** setting. For faster cooking, adjust the control knob to the **HI** setting.
  2. Place the food on the **RIGHT** side of the cooking grate.
  3. Because the heat source is only on one side, the food should be rotated at least once during cooking to insure even cooking. Use a meat thermometer to determine when the food is done.

## Food Safety

Food safety is a very important part of enjoying the outdoor cooking experience. To keep food safe from harmful bacteria, follow these four basic steps:

**Clean:** Wash hands, utensils, and surfaces with hot soapy water before and after handling raw meat and poultry.

**Separate:** Separate raw meats and poultry from ready-to-eat foods to avoid cross contamination. Use a clean platter and utensils when removing cooked foods.

**Cook:** Cook meat and poultry thoroughly to kill bacteria. Use a thermometer to ensure proper internal food temperatures.

**Chill:** Refrigerate prepared foods and leftovers promptly.

**For more information call: USDA Meat and Poultry Hotline at 1-800-535-4555 In Washington, DC (202) 720-3333, 10:00 am-4:00 pm EST.**

## How To Tell If Meat Is Grilled Thoroughly

- Meat and poultry cooked on a grill often browns very fast on the outside. Use a meat thermometer to be sure food has reached a safe internal temperature, and cut into food to check for visual signs of doneness.
- Whole poultry should reach 180° F; breasts, 170° F. Juices should run clear and flesh should not be pink.
- Hamburgers made of any ground meat or poultry should reach 160° F, and be brown in the middle with no pink juices. Beef, veal and lamb steaks, roasts and chops can be cooked to 145° F. All cuts of pork should reach 160° F.
- **NEVER** partially grill meat or poultry and finish cooking later. Cook food completely to destroy harmful bacteria.
- When reheating takeout foods or fully cooked meats like hot dogs, grill to 165° F, or until steaming hot.

## Cooking Chart

Cooking times and temperatures may vary according to specific recipes, cooking conditions or barbecue equipment used. Take these factors into consideration to insure best results. If you use the indirect cooking method (indirect cooking is lighting only one burner and placing food on opposite side of cooking grate), allow more grilling time.

Temperatures: High = 650°F / Medium = 450°F / Low = 300°F.

Food	Setting	Cooking Time
<b>Beef</b> Hamburger 1/2" thick	Medium	Med: 7-10 min. / Well done: 10-15 min.
Steak 1/2"	Medium-Hot	Rare: 3-6 min. / Med: 6-9 min. / Well done: 9-12 min.
Roast	Low	Rare: 18-22min. per lb. / Med: 22-28 min. per lb. / Well done: 28-32 min. per lb.
<b>Pork</b> Chops 1/2"	Medium	Well done: 15-20 min.
Ribs 5-6 lbs.	Low-Medium	Well done: 45-90 min.
Roast 3-5 lbs.	Low-Medium	Well done: 18-23 min. per lb.
Ham Steak 1/2"	Medium-Hot	12-15 min.
Ham 5 lb. fully cooked	Low-Medium	20 min. per lb.
<b>Lamb</b> Chops 1/2"	Medium	6-12 min.
<b>Poultry</b> Chicken 2-1/2 to 3-1/2 lbs.	Low	1 hr., 15 min. to 1 hr., 30 min.
Chicken halved or quartered	Low	40-60 min.
Turkey	Low-Medium	18-20 min. per lb.
<b>Seafood</b> Steaks 1" thick	Medium-Hot	Well done: 10-25 min.
Fillets 6-8 oz.	Medium-Hot	8-12 min.
Shrimp large or jumbo	Low-Medium	8-12 min.
<b>Venison</b> Steak 1" thick	Medium	Rare: 8-10 min. / Med: 10-12 min.
Burgers 1/2"	Medium	Rare: 10-12 min. / Med: 12-15 min.
Roast 3-4 lbs.	Low-Medium	Rare: 20-22 min. per lb. / Med: 22-25 min. per lb.
<b>Vegetables</b> Baking Potato whole	Low	<i>Wrap vegetables in foil</i> 55-60 min.
Onions whole	Low	45 min.
Tomatoes half	Medium	30-40 min.
Corn whole	Low	35-45 min.
Mushrooms	Medium	15-20 min.

## Troubleshooting

Problem	Possible Cause	Prevention/Solution
Burner(s) will not light using ignitor.	<ul style="list-style-type: none"> <li>• Wire and/or electrode covered with cooking residue.</li> <li>• Electrode and burner are wet.</li> <li>• Electrode cracked or broken "sparks at crack"</li> <li>• Wire is loose or disconnected.</li> <li>• Wire is shorting (sparking) between ignitor and electrode.</li> <li>• Bad ignitor.</li> </ul>	<ul style="list-style-type: none"> <li>• Clean wire and/or electrode with rubbing alcohol and clean swab.</li> <li>• Wipe dry with cloth.</li> <li>• Replace electrode.</li> <li>• Reconnect wires or replace electrode/wire assembly.</li> <li>• Replace ignitor wire/electrode assembly.</li> <li>• Replace ignitor.</li> </ul>
Burner(s) will not match light.	<ul style="list-style-type: none"> <li>• No gas flow.</li> <li>• Coupling nut and regulator not fully connected.</li> <li>• Obstruction of gas flow.</li> <li>• Disengagement of burner to valve.</li> <li>• Is grill assembled correctly?</li> </ul>	<ul style="list-style-type: none"> <li>• Check to see if LP tank is empty. If LP tank is not empty, refer to "<i>Sudden drop in gas flow</i>" below.</li> <li>• Turn the coupling nut about one-half to three quarters additional turn until solid stop. Tighten by hand only-do not use tools.</li> <li>• Clear burner tube(s).</li> <li>• Reengage burner and valve. Reattach spring clips.</li> <li>• Check steps in assembly instructions.</li> </ul>
Sudden drop in gas flow or low flame.	<ul style="list-style-type: none"> <li>• Out of gas.</li> <li>• Excess flow valve tripped.</li> </ul>	<ul style="list-style-type: none"> <li>• Check for gas in LP tank.</li> <li>• Turn off knobs, wait 30 seconds and light grill. If flames are still low, turn off knobs and LP tank valve. Disconnect regulator. Reconnect regulator and leak test. Turn on LP tank valve, wait 30 seconds and then light grill.</li> </ul>
Flames blow out.	<ul style="list-style-type: none"> <li>• High or gusting winds.</li> <li>• Low on LP gas.</li> <li>• Excess flow valve tripped.</li> </ul>	<ul style="list-style-type: none"> <li>• Turn front of grill to face wind or increase flame height.</li> <li>• Refill LP tank.</li> <li>• Refer to "<i>Sudden drop in gas flow</i>" above.</li> </ul>
Flare-up.	<ul style="list-style-type: none"> <li>• Grease buildup.</li> <li>• Excessive fat in meat.</li> <li>• Excessive cooking temperature.</li> </ul>	<ul style="list-style-type: none"> <li>• Clean grill.</li> <li>• Trim fat from meat before grilling.</li> <li>• Adjust (lower) temperature accordingly.</li> </ul>
Persistent grease fire (can damage the appearance of aluminum castings on the grill).	<ul style="list-style-type: none"> <li>• Grease trapped by food buildup around burner system.</li> </ul>	<ul style="list-style-type: none"> <li>• Turn knobs to OFF. Turn gas off at LP tank. Leave lid in position and let fire burn out. <i>After grill cools, remove, clean all parts and replace grease can.</i></li> </ul>
Flashback... (fire in burner tube(s)).	<ul style="list-style-type: none"> <li>• Burner and/or burner tubes are blocked.</li> </ul>	<ul style="list-style-type: none"> <li>• Turn knobs to OFF. Clean burner and/or burner tubes.</li> </ul>
Unable to fill LP tank.	<ul style="list-style-type: none"> <li>• Some dealers have older fill nozzles with worn threads.</li> </ul>	<ul style="list-style-type: none"> <li>• The worn nozzles don't have enough "bite" to engage the valve. Try a second LP dealer.</li> </ul>





# Get it fixed, at your home or ours!

## Your Home

For repair—in your home—of **all** major brand appliances, lawn and garden equipment, or heating and cooling systems, **no matter who made it, no matter who sold it!**

For the replacement parts, accessories and owner's manuals that you need to do-it-yourself.

For Sears professional installation of home appliances and items like garage door openers and water heaters.

**1-800-4-MY-HOME® (1-800-469-4663)**

Call anytime, day or night (U.S.A. and Canada)

[www.sears.com](http://www.sears.com)    [www.sears.ca](http://www.sears.ca)

---

## Our Home

For repair of carry-in items like vacuums, lawn equipment, and electronics, call or go on-line for the location of your nearest **Sears Parts & Repair Center.**

**1-800-488-1222**

Call anytime, day or night (U.S.A. only)

[www.sears.com](http://www.sears.com)

---

To purchase a protection agreement (U.S.A.) or maintenance agreement (Canada) on a product serviced by Sears:

**1-800-827-6655** (U.S.A.)

**1-800-361-6665** (Canada)

---

Para pedir servicio de reparación a domicilio, y para ordenar piezas:

**1-888-SU-HOGAR<sup>SM</sup>**

(1-888-784-6427)

Au Canada pour service en français:

**1-800-LE-FOYER<sup>MC</sup>**

(1-800-533-6937)

[www.sears.ca](http://www.sears.ca)

# SEARS

® Registered Trademark / <sup>TM</sup> Trademark / <sup>SM</sup> Service Mark of Sears, Roebuck and Co.

® Marca Registrada / <sup>TM</sup> Marca de Fábrica / <sup>SM</sup> Marca de Servicio de Sears, Roebuck and Co.

<sup>MC</sup> Marque de commerce / <sup>MD</sup> Marque déposée de Sears, Roebuck and Co.

© Sears, Roebuck and Co.