















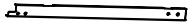







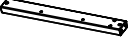



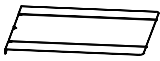

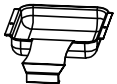
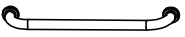
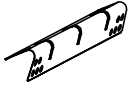

No.	#	QTY / CANT. / QTÉ	Description / Descripción / Description	Image / Imagen / Image
1	05-JSL-36	2	Leg base Base de la pata Base des pieds	
2	05-SLL-02	2	Wheel Rueda Roue	
3	AJDB044B	1	Bottom shelf Estante inferior Etagere inferieure	
4	06-XZL-1-20-DY	1	Wheel axle Eje de las ruedas Axe de roue	
5	05-LGL-05-WH	2	Rim cover Cubierta de la llanta Couverture de la jante	
6	AJQPGDZ01	1	Screw bushing Buje del perno de fijación de la bombona Douille de vis	
7	07-QPG-05-SI	1	LP cylinder screw Perno de fijación de la bombona Vis de bouteille de gaz	
8	AJBJTLF01	1	Left front leg Pata delantera izquierda Jambe avant gauche	
9	AJBJTRF01H	1	Right front leg Pata delantera derecha Jambe avant droite	
10	AJBJTLB01	1	Left back leg Pata trasera izquierda Jambe arrière gauche	
11	AJBJTRB01H	1	Right back leg Pata trasera derecha Jambe arrière droite	
12	AJQDB024B	1	Cart board Panel de carro Panneau du chariot	
13	AJQZSB014B	1	Decoration board Panel decorativo Panneau de décoration	
14	AJQHL03H4B	1	Cart front beam Barra frontal del carro Poutre avant du chariot	
15	AJHHL02H4B	1	Cart beam Barra del carro Poutre du chariot	
16	AJCHL02	2	Cart side beam Viga lateral del carro Poutre latérale du chariot	
17	06-XZL-3-24-DD1	1	Paper towel holder Portarrollos de papel Porte-serviettes en papier	

No.	#	QTY / CANT. / QTÉ	Description / Descripción / Description	Image / Imagen / Image
18	03-WZJ-A-01-DD1	1	Trash bag holder Marco para bolsas de basura Porte-sac poubelle	
19	06-XZL-4-01-DD1	1	LP cylinder barrier bar Barra de seguridad para la bombona de gas Barre de barrière de bouteille de gaz	
20		1	Main body Cuerpo principal Corps principal	
21	AJQPGB01-DS1	1	Thermal baffle Deflector térmico Panneau isolant	
22	AB31BL03H	1	Side burner shelf Base del quemador lateral Étagère du bruleur d'appoint	
23	AT31GDCTR01H	1	Side shelf Bandeja lateral Étagère latérale	
24	06-XNZ-5-01	1	Knob base Base de mando de regulación de llama Base du bouton	
25	06-XNL-5-17ABK -PDD1-PBK-RGC	1	Knob Mando de regulación de llama Bouton	
26	ALJYP014B-DS2	1	Grease tray Bandeja de recogida de grasa Lèchefrite	
27	ALYB01H-LS4	1	Grease cup Depósito de recogida de grasa Bac à graisse	
28	04-GBS-2-54- 500-PG	1	Lid handle Manija de la tapa Poignée du couvercle	
29	ALFHB01-SS4	4	Flame tamer Regulador de llama Atténuateur de flam	
30	ALFHB02-SS4	1	Flame tamer (big) Regulador de llama (grande) Gros atténuateur de flamme	
31	03-ZTW-A-01-TC4	2	Cooking grate Rejilla para asar Grille de cuisson	
32	01-LTL-4-19-230 -F-SS4	1	Side burner Quemador lateral Bruleur d'appoint	
33	03-GJL-08-TC3	1	Side burner grate Rejilla del quemador lateral Grille du bruleur d'appoint	
34	03-BWW-A-01-4B -DD1	1	Warming rack Rejilla para calentar Grille de réchauffemen	

No.	#	Image / Imagen / Image	No.	#	Image / Imagen / Image
A	M6×12	×38	G	Washer Arandela Rondelle	×6
B	M5×10	×23	H	M6×20	×2
C	M4×12	×1	I	M6	×2
D	Split pin Pasador partido Goupille fendue	×1	J	Washer Arandela Rondelle	×2
E	Pad Arandela Tampon	×2	K	M4×8	×4
F	Hose holder Anilla de fijación Support de tuyau	×1			

TOOLS REQUIRED / HERRAMIENTAS REQUERIDAS / OUTILS REQUIS

Phillips screwdriver Destornillador phillips Tournevis phillips	Wrench Llave Clé	
---	------------------------	--

Before beginning assembly, make sure all parts are present. If any parts are missing or damaged, do not attempt to assemble the products. Contact customer service for replacement parts via telephone or email.

- Tools needed (not included): Phillips screwdriver and wrench
- Approximate assembly time: 45-60 minutes
- Note: 1. The right and left sides of the grill are designed as if you are facing the front of the grill.
2. Model shown for illustration purpose only, specific please in kind prevail.

Antes de comenzar el montaje, asegúrese de que todas las piezas estén presentes. Si falta alguna pieza o está dañada, no intente ensamblar los productos. Póngase en contacto con el servicio de atención al cliente para obtener piezas de repuesto por teléfono o correo electrónico.

- Herramienta necesaria (no incluido): Destornillador phillips y llave
- Tiempo aproximado de ensamblaje: 45-60 minutos
- Nota: 1. Los lados derecho e izquierdo de la parrilla están diseñados como si estuvieras frente a la parte delantera de la parrilla.
2. El modelo que se muestra es sólo para fines ilustrativos, prevalecen los específicos en especie.

Avant de commencer l'assemblage, assurez-vous que toutes les pièces sont présentes. Si des pièces sont manquantes ou endommagées, n'essayez pas d'assembler les produits. Contactez le service de clientèle pour les pièces de rechange par téléphone ou par e-mail.

- Outils nécessaires (non inclus): Tournevis phillips et clé
- Temps nécessaire pour l'assemblage: 45-60 minutes
- Remarque: 1. les côtés droit et gauche du gril sont conçus comme si vous faisiez face à l'avant du gril.
2. le modèle est présenté à des fins d'illustration uniquement, spécifiques en nature prévalent.

1 A  ×2

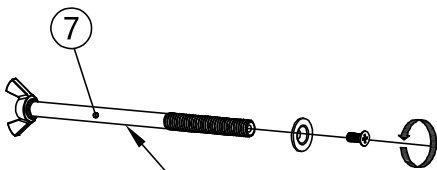
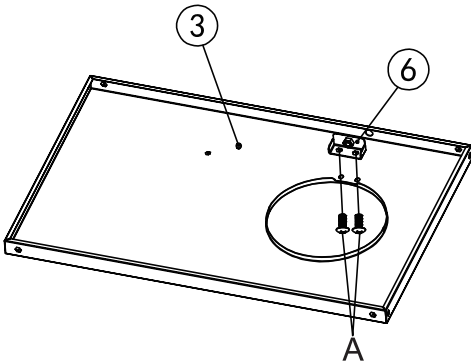

- Use the pre-installed screws from the LP cylinder screw.
- Utilice los tornillos preinstalados del tornillo del cilindro LP.
- Utilisez les vis préinstallées de la bonbonne de GPL.

2

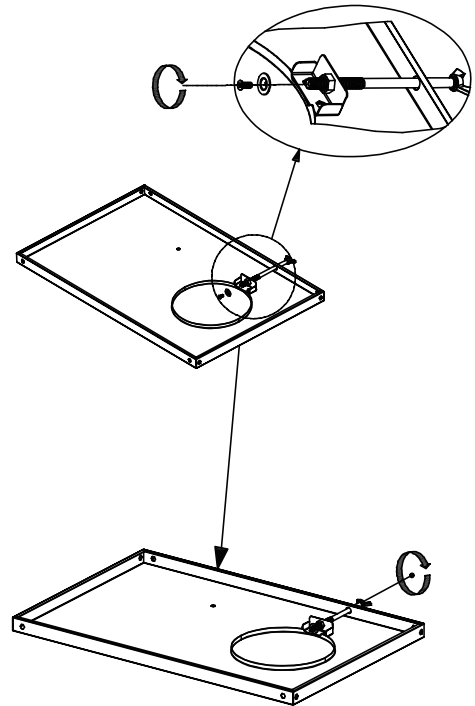

3 A  ×4

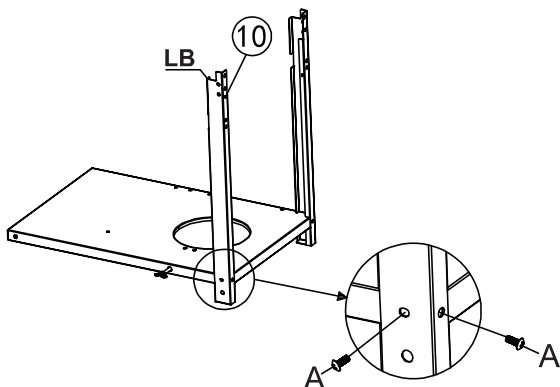
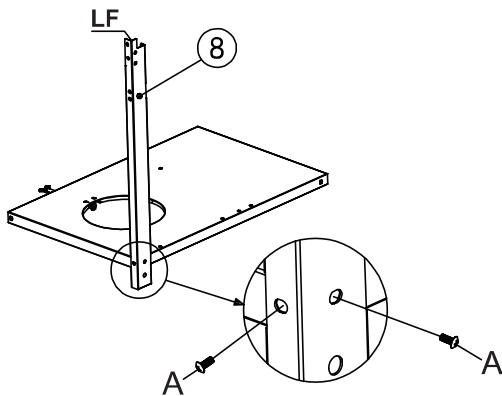

4

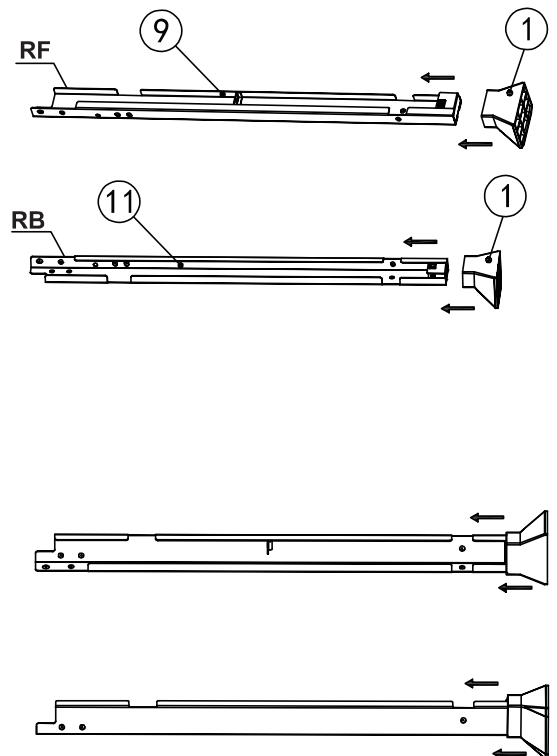

5 A  ×4

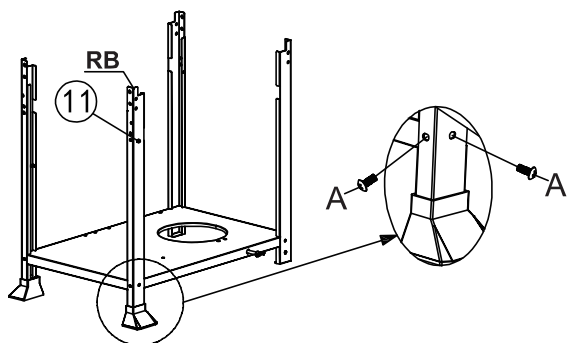
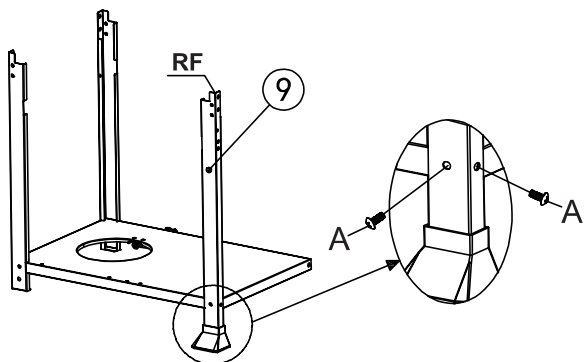

6 A  ×4

- Do not fully tighten the screws A until step 18 and 19.
- No apriete completamente los tornillos A hasta el paso 18 y 19.
- Ne serrez pas à fond les vis A avant l'étape 18 et 19.

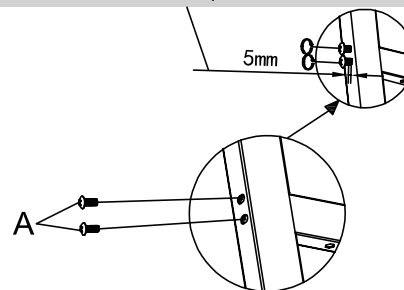

- Note direction
- Dirección de la nota.
- Direction de la note.

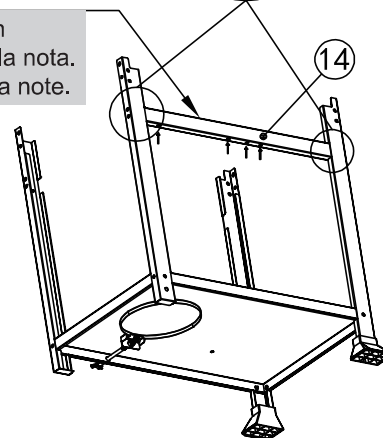

7 A  ×4

- Do not fully tighten the screws A until step 18 and 19.
- No apriete completamente los tornillos A hasta el paso 18 y 19.
- Ne serrez pas à fond les vis A avant l'étape 18 et 19.

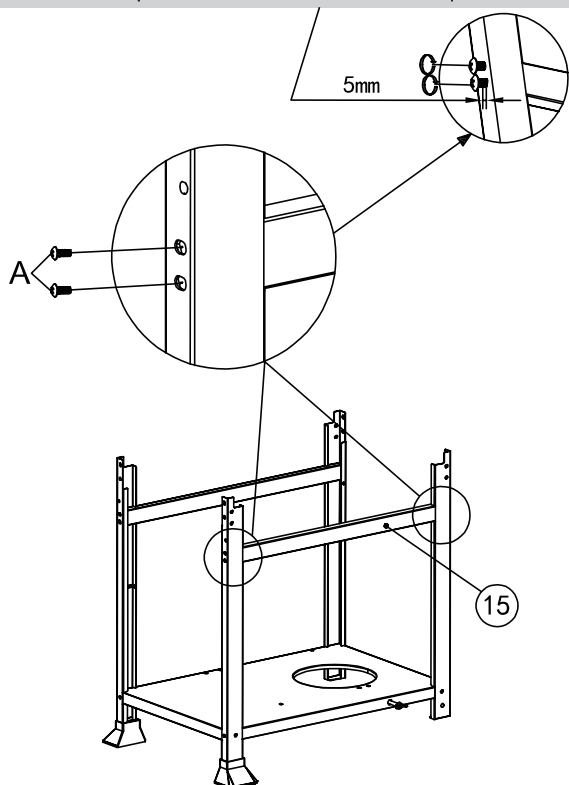

8 B  ×4

- With holes in these two positions is the front side.
- El lado frontal es el que tiene agujeros en estas dos posiciones.
- Lorsque les trous sont dans ces deux positions, c'est la face avant.

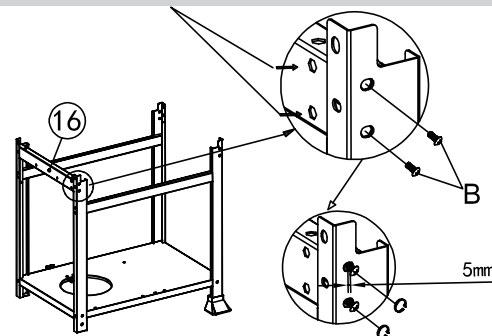

- Do not fully tighten the screws B until step 18.
- No apriete completamente los tornillos B hasta el paso 18.
- Ne serrez pas à fond les vis B avant l'étape 18.

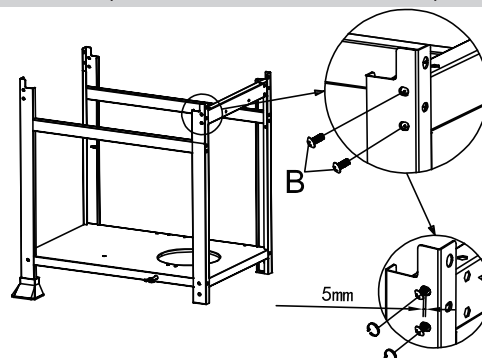

9 B  ×4

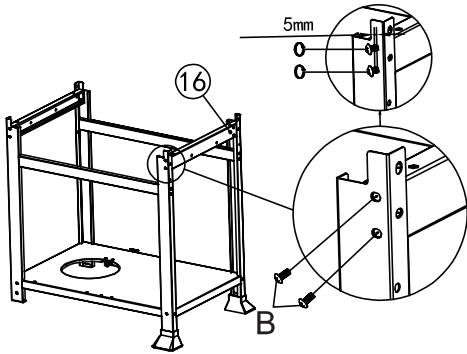

- Do not fully tighten the screws B until step 18.
- No apriete completamente los tornillos B hasta el paso 18.
- Ne serrez pas à fond les vis B avant l'étape 18.

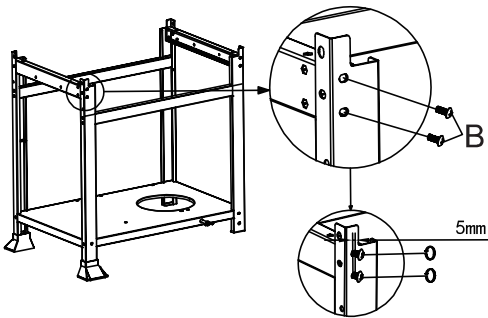

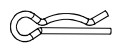
10 E  ×2
D  ×1

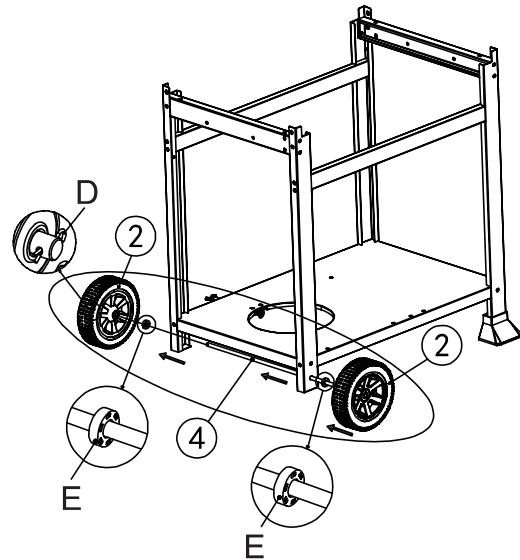

11

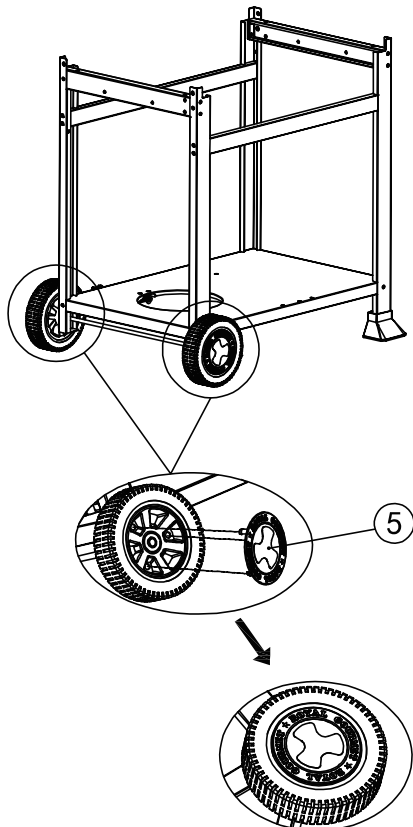

12 B  ×8

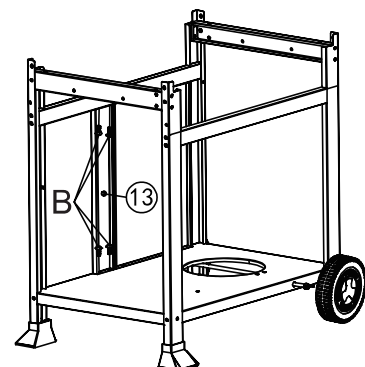
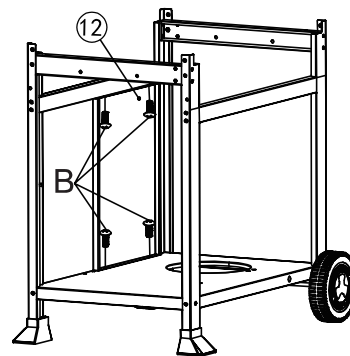

13 A  ×2

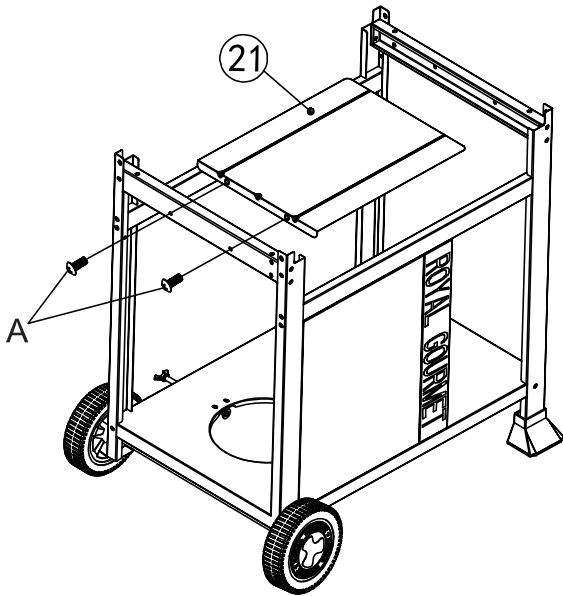

14 B  ×2

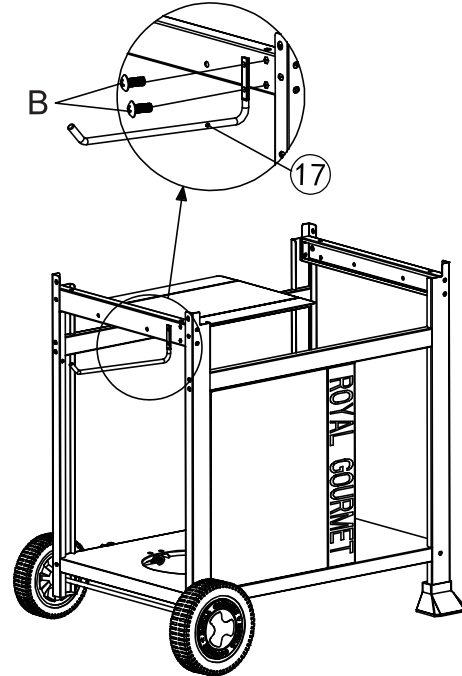

15 B  ×1

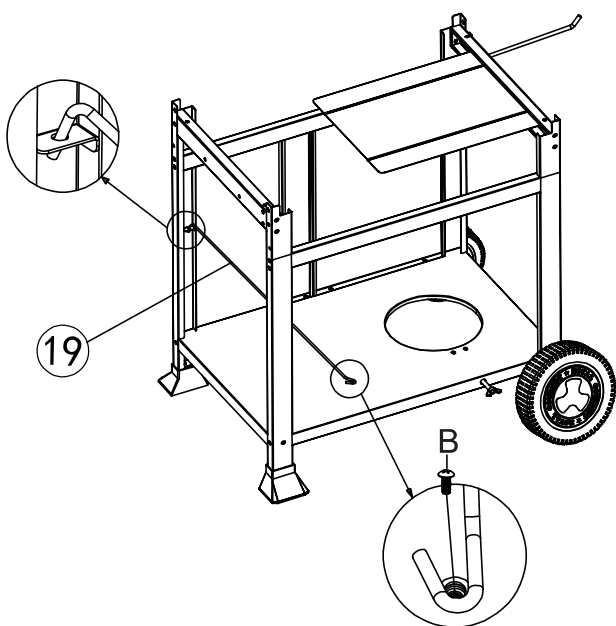

16

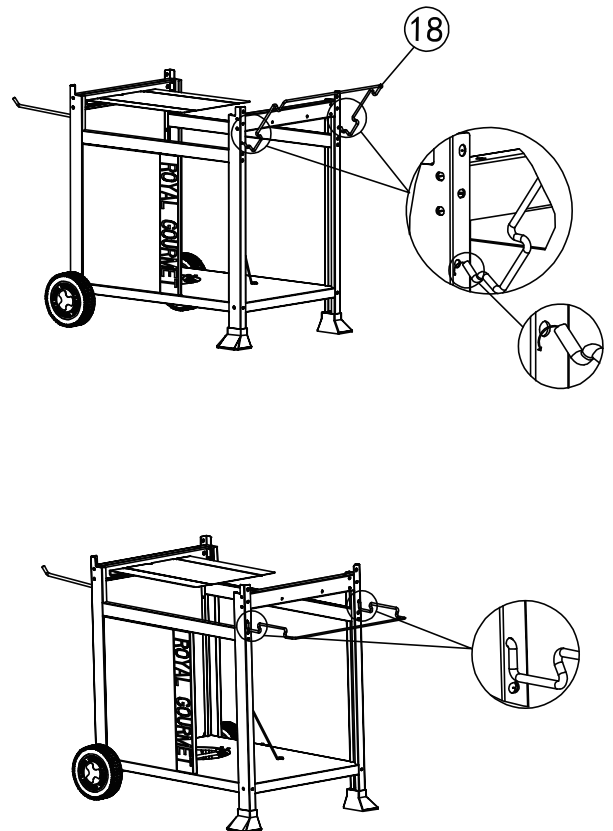

17

- Ignition module
- Módulo de ignición
- Module d'allumage

- Side burner valve
- Válvula del quemador lateral
- Valve de brûleur latéral

- Regulator
- Module d'allumage
- Détendeur

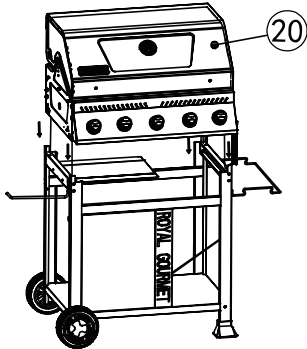
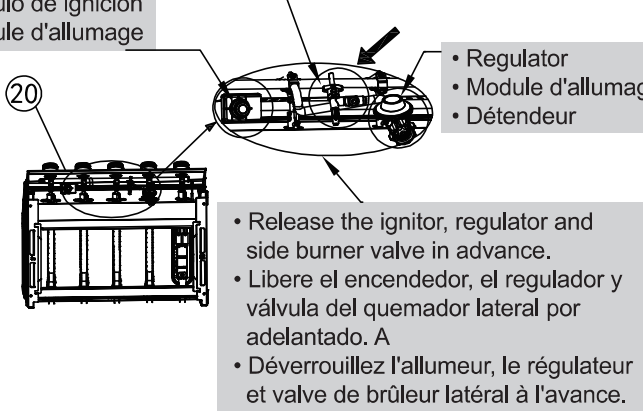

18

A



×4

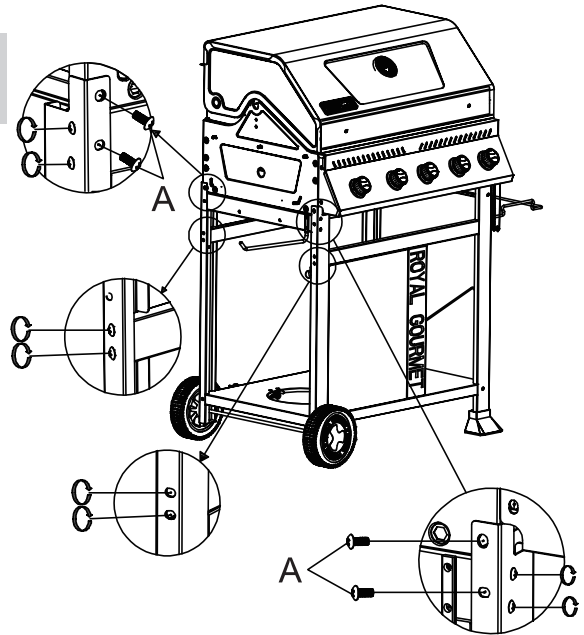

19

A



×4

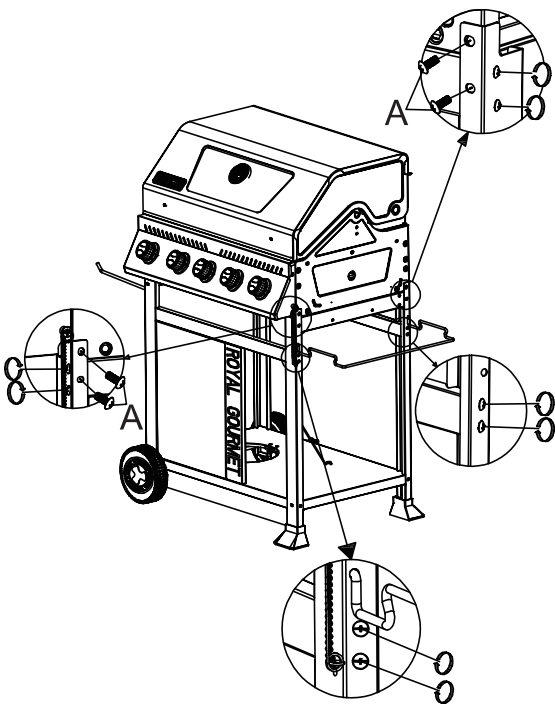

20

G





×3

A



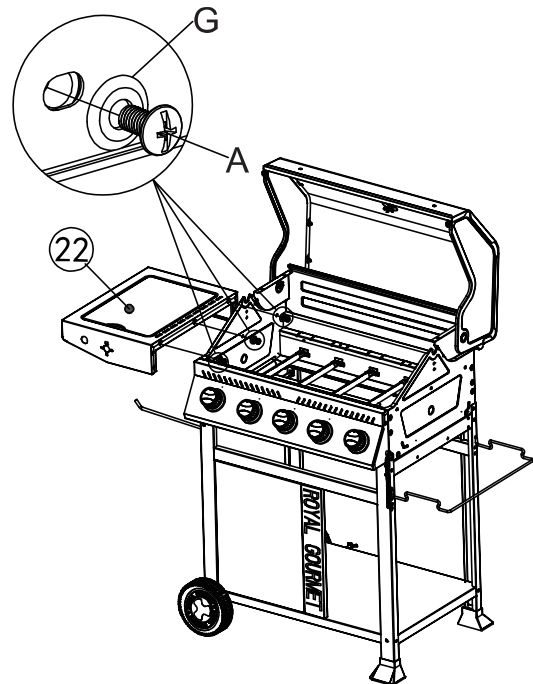

×3



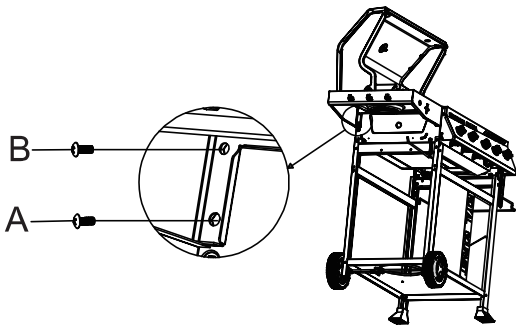
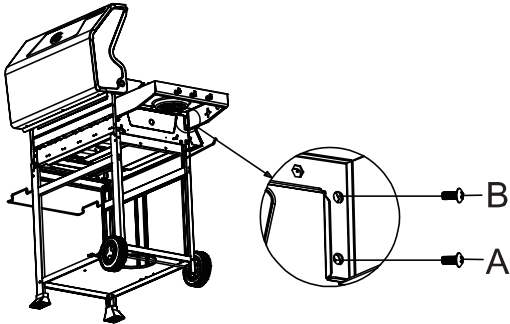

21	B		×2
	A		×2

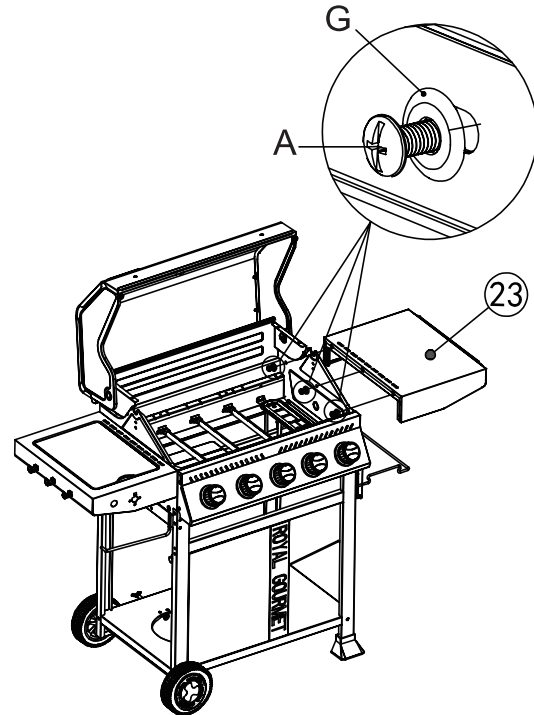

22	G		×3
	A		×3



23	B		×2
	A		×2

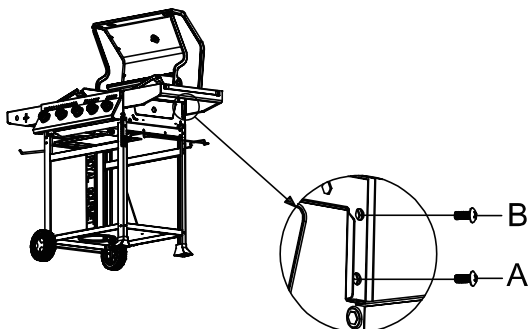
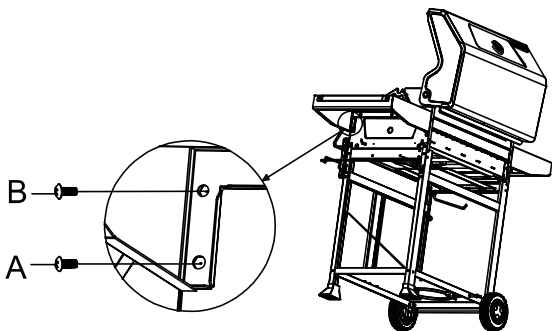

24	K		×2
-----------	---	---	----

- Insert the valve through the control panel
- Inserte la válvula a través del panel de control
- Insérez la vanne à travers le panneau de commande

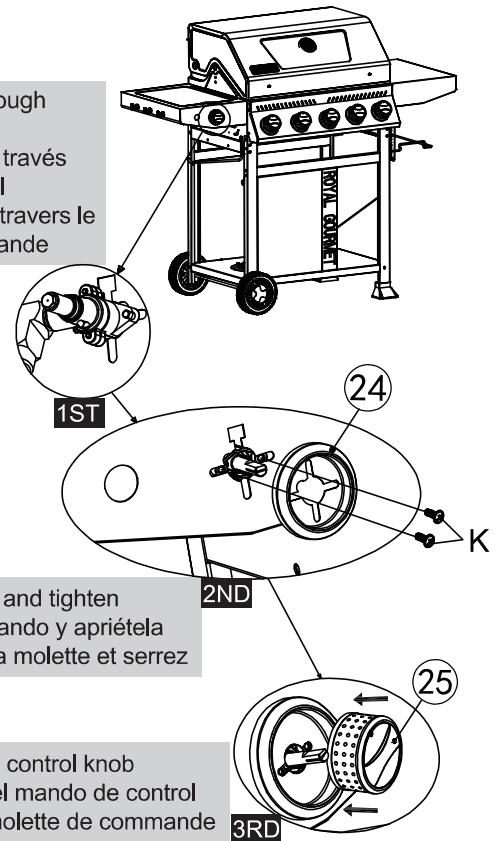

- Install the knob base and tighten
- Instale la base del mando y apriétela
- Installez la base de la molette et serrez

- Attach the control knob
- Coloque el mando de control
- Fixez la molette de commande

25 K  ⊕ ×2

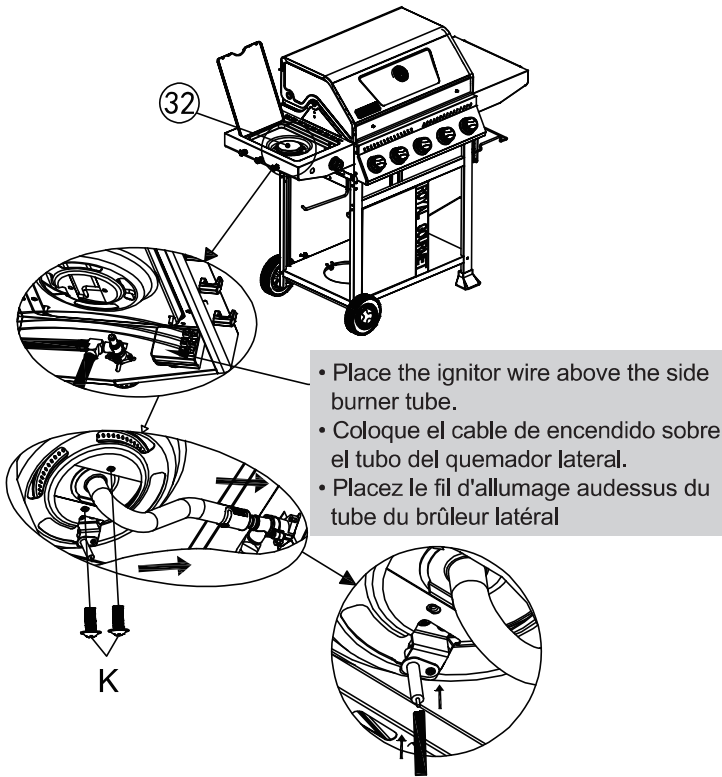

26

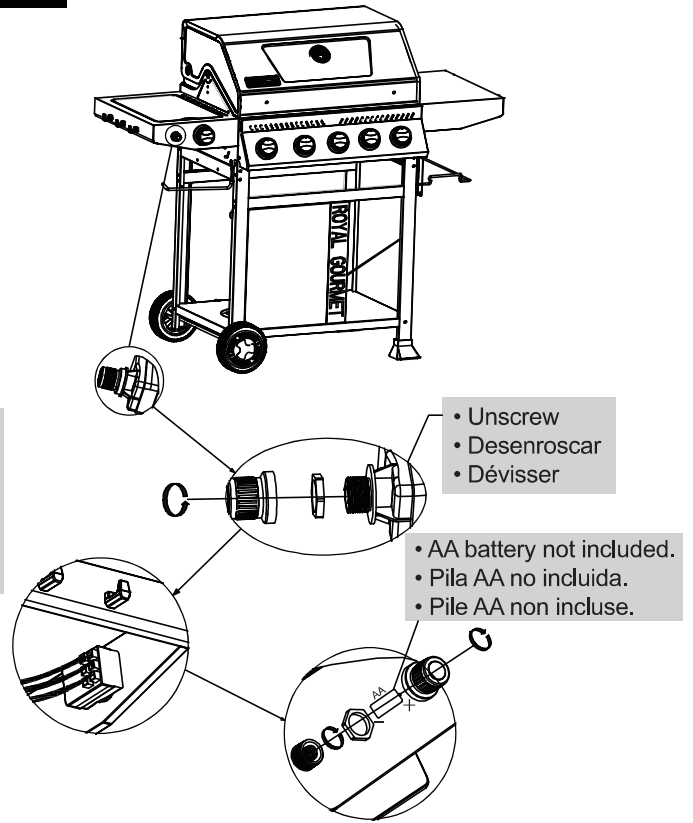

27

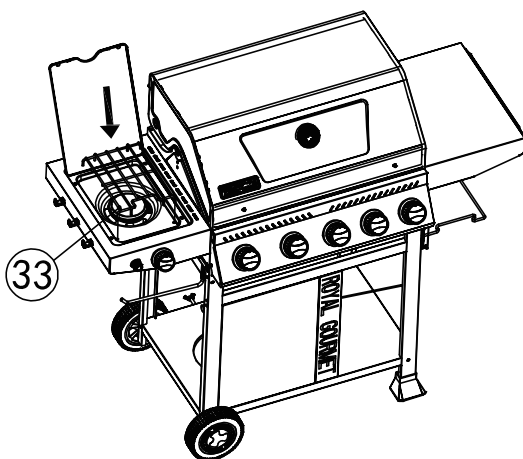



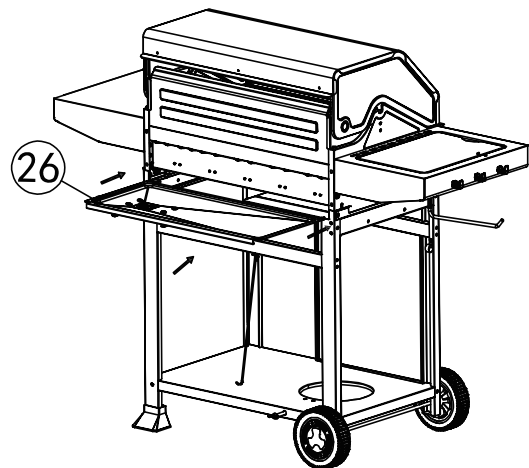

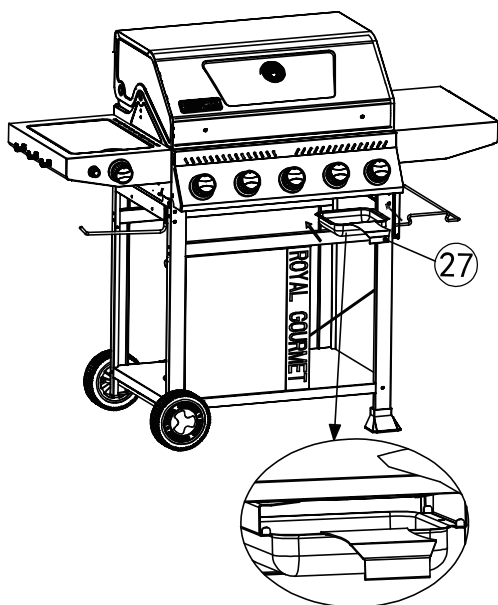

28



29



30

J			×2
H			×2
I			×2

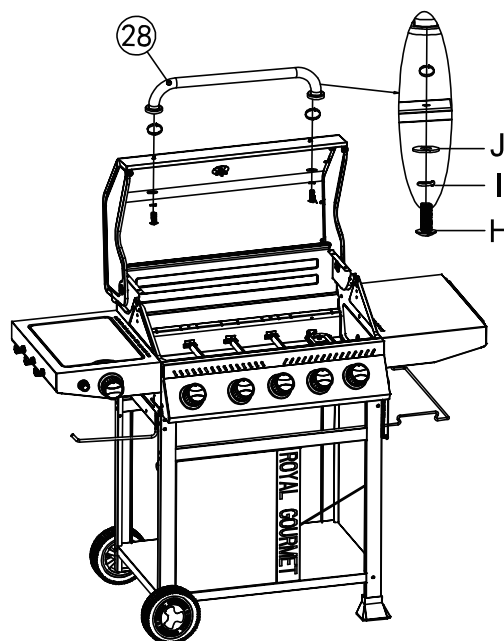

31

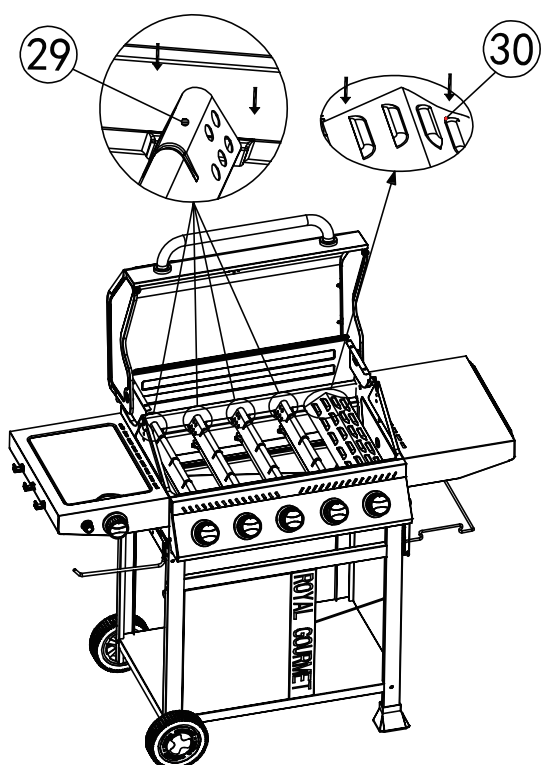

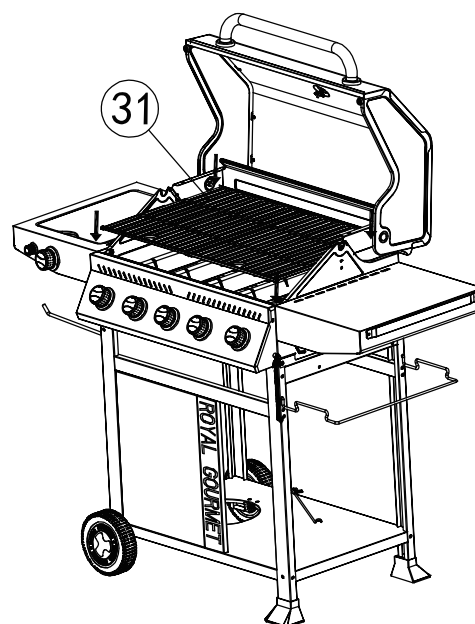

32

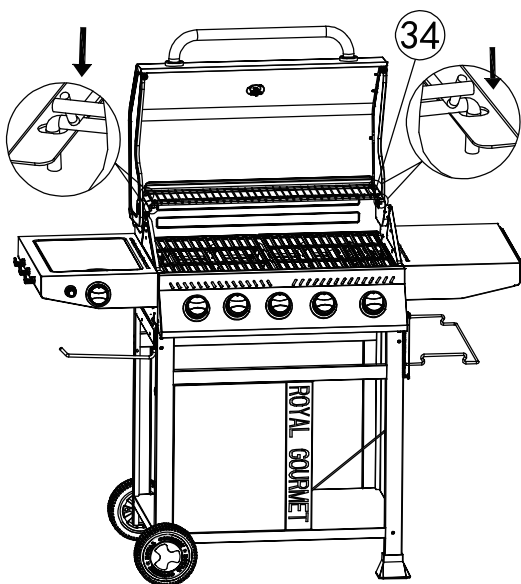

33



34

C		×1
F		×1

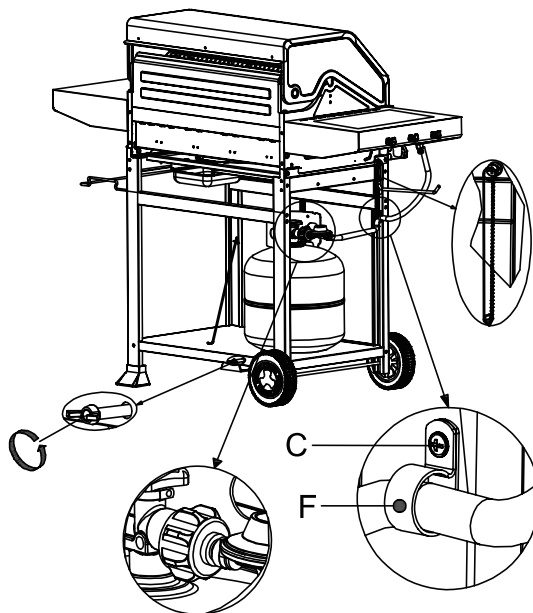

**Thank You
For Choosing Us.**

**Any Problem!
We Can Help!**

**Customer
Service**

1-800-618-6798

Monday to Friday (8:30 am - 5:00 pm EST)

service@royalgourmetusa.com