

PPH 320-12



*Original Instructions -
Warning! Read instructions before using the machine.*

*Attention :
Lisez la notice avant d'utiliser la machine.*





Assembly - Assemblage

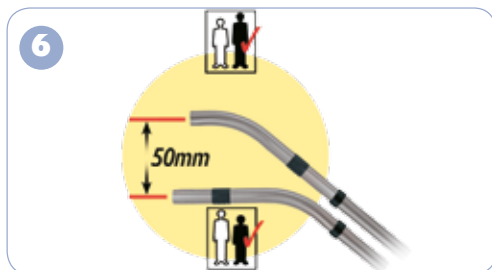
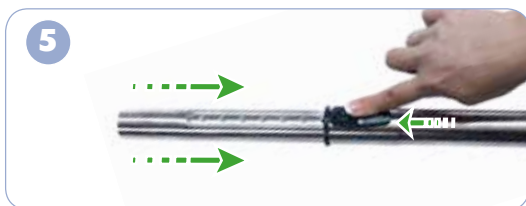

Using your machine - Utilisation de la machine



1
Start
Démarrage
2
Lo / Hi Speed
Lo / Hi Vitesse



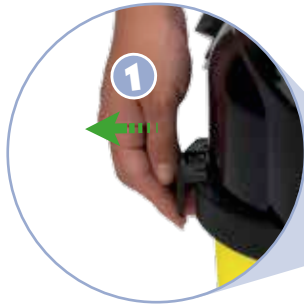

Replacing HEPA filters process



Replace the HEPA filter with an identical NaceCare approved part NVM 24B (604124)

Wand docking



Cleaning the Tool Head



PPH Plugged Cable



PPH Plugged Cable





Rating Label

- 1 Voltage
- 2 Frequency
- 3 Rated Input Power
- 4 Weight (ready to work)
- 5 Company Name & Address
- 6 Model
- 7 Machine yr/wk Serial number
- 8 Approval Mark
- 9 Protection Class 2 Symbol



PPE (personal protective equipment) That may be required for certain operations.



Ear Protection



Safety Footwear



Head Protection



Safety Gloves



Eye Protection



Protective Clothing



Dust / Allergens Protection



Hi Vis Jacket



Caution Floor Sign

NOTE: A risk assessment should be conducted to determine which PPE should be worn.

Safety Critical Components

Mains leads:

SJT(1050C) 12.5 m x 18 AWG x 2 core

WEEE Legislation

(Waste, Electrical and Electronic Equipment)

Vacuum cleaner, accessories and packaging should be sorted for environmentally - friendly recycling.

(Only for EU Countries)

Do not dispose of vacuum cleaner into household waste! According to the European Directive 2002 / 96 / EC on waste electrical and electronic equipment and its incorporation into national law.

Vacuum cleaners that are no longer suitable for use must be separately collected and sent for recovery in an environmentally - friendly manner.



Failure to rectify the problem or in the event of a breakdown contact your Numatic dealer or the Numatic Technical helpline +44 (0)1460 269268

Data

Motor	Drum Size	Cleaning Range	Weight (Ready to work)	Sound Pressure	Protection Class	Dimensions
620W	2.7 US Gal	104.3 ft	17 lbs	64 dB (A) Uncertainty 0.5 dB	Class II	14" x 14" x 18.3"

Replacement parts

TriTex / Microfresh Filter, Primärfilter/Filter, Filter	
604311	MicroTex Filter
HepaFlo Dust Bags, Filtre	
604016	NVM 2BH (Pack of 10)

Information for DRY USE Vacuum cleaners



WARNING

Ensure you read the instruction manual before using the machine.

Operators shall be adequately instructed on the use of these machines, as with all electrical equipment, care and attention must be exercised at all times during use, you must also make certain that routine and preventative maintenance is carried out periodically to ensure safe operation.

Failure to carry out maintenance as necessary, including the replacement of parts to the correct standard could render this equipment unsafe and the manufacturer can accept no responsibility in this respect.

This machine is for DRY USE only

You must disconnect the machine from the mains by removing the plug from the supply socket BEFORE cleaning or maintenance and when replacing parts or converting the machine to another function.

This appliance is intended to be assembled, cleaned and maintained by an adult.

This machine is not suitable for the collection of biological hazards, hazardous or explosive dusts. Contact your local distributor if you require a machine capable of performing these tasks.

This machine is not a toy; children shall not play with this machine.

The machine must not be used by persons with reduced physical, sensory or mental capabilities, or lack of experience or knowledge, unless they have been given supervision or instruction.

You must not allow the supply cord to come into contact with rotating brushes (if fitted).

Only use the socket outlet on the machine for purposes specified in the instructions (where fitted).



CAUTION

This machine must not be stored outside, or used in wet environments, or to collect wet materials.

The vacuum cleaner should be stored in a dry place and is for indoor use only.

You must ensure that the filtration system fitted to the machine is suitable for the material being collected.

NOTES

This product complies with the requirements of CAN / CSA E 60335-2.69.

The primary use for this machine is commercial, for example in hotels, schools, hospitals, factories, shops and offices.

If the vacuum cleaner stops working, remove the plug from the wall before investigating where the fault lies.

If the vacuum cleaner has a blockage, switch off, remove the plug from the socket outlet, and inspect the floor tool, wands and hose for debris. If the floor tool, wands and hose are clear, replace the dust bag and clean the filter.

The vacuum cleaner should be inspected after use for damage.

The power light will illuminate, when your machine is connected to a suitable power supply.



DO

- Keep your machine clean.
- Keep filters clean.
- Use filter bags, they will enhance performance and help keep machine clean.
- Use a Numatic original filter bag under fine dust conditions.
- Keep hoses and tubes clear.
- Replace any worn or damaged parts immediately.
- Regularly examine the power cord. If damage is found such as cracking or ageing the power cord must be replaced by a competent person using the correct Numatic original part.

- Change dust bag frequently.
- Keep diffuser filter (where fitted) clean.
- Only use the brushes provided with the machine. The use of other brushes may impair safety.



DON'T

- Unreel the cable with one pull or pull on the cable to unplug the machine from the power supply.
- Use to suck up hot ashes or lighted cigarette ends.
- Use steam cleaners, pressure washers or immerse in water to clean the machine.
- Attempt machine maintenance or cleaning unless the power supply plug has been removed from the supply outlet.
- Use in a wet environment or to collect wet materials.
- Store your machine in wet conditions.



Plaque signalétique

- 1 Tension d'alimentation
- 2 Fréquence
- 3 Puissance
- 4 Poids brut
- 5 Nom et adresse du fabricant
- 6 Description machine
- 7 Numéro de série année semaine
- 8 Approbation
- 9 Symbole Classe 2

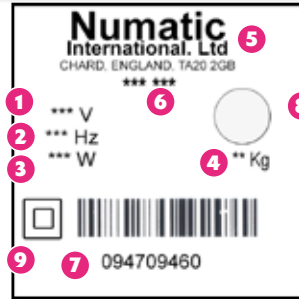

EPI (Equipelement de Protection Individuel) Recommandés pour certaines applications :



Protections sonores



Chaussures de sécurité



Casque de protection



Gants de protection



Lunettes de protection



Vêtements de sécurité



Protection contre poussières / allergènes



Gilet de haute visibilité



Panneau de signalisation au sol

Note :

Une évaluation des risques devra être menée pour définir les obligations d'utilisation des EPI.

Composants de sécurité critiques :

Câble d'alimentation

SJT(1050C) 12.5 m x 18 AWG x 2 core

Législation WEEE (DEEE)

Les aspirateurs, accessoires et emballages répondent aux critères de recyclage et d'environnement.

Pour CEE seulement :

Ne pas jeter l'aspirateur comme déchet ménager.

En accord avec la directive 2002/96/EC du 27 janvier 2003 sur les déchets électriques et électroniques (Directive WEEE pour Waste Electrical and Electronic Equipment) et ses applications au niveau national, les aspirateurs en fin de vie doivent être collectés et récupérés par un organisme compétent en matière de gestion environnementale des déchets.

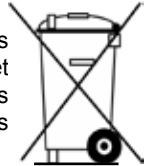

Caractéristiques

Moteur	Taille de cuve	Champs d'action	Poids (prêt à l'emploi).	Niveau d'émission sonore	Classe de protection	Dimensions
620W	2.7 US Gal	104.3 ft	17 lbs	64 dB (A) Uncertainty 0.5 dB	Class II	14" x 14" x 18.3"

Replacement parts - Pièces Détachées

Primärfiltre/Filtre	
604311	MicroTex Filtre
HepaFlo Dust Bags, Filtre	
604016	NVM 2BH (Pack of 10)

Information relative aux aspirateurs à poussière.

Assurez-vous d'avoir lu le manuel d'instruction avant d'utiliser l'appareil.



ATTENTION

Les utilisateurs doivent avoir reçu une formation adaptée à l'utilisation de cet appareil. Ils doivent être vigilants et prendre en permanence les précautions relatives à l'utilisation de tout matériel sous tension. Ils devront s'assurer que la maintenance courante et préventive de l'appareil soit effectuée régulièrement pour garantir la sécurité de son utilisation.

Tout défaut d'entretien de cet appareil, ou le remplacement de pièces par des pièces autres que celles d'origine pourrait rendre l'appareil dangereux. Le constructeur ne pourra en aucun cas être tenu responsable en cas de manquement relatif à l'entretien de la machine.

Cet aspirateur est destiné à l'aspiration de poussières sèches uniquement.

Débrancher impérativement la prise d'alimentation de l'appareil avant d'entreprendre toute opération de nettoyage, de maintenance, pour le remplacement d'une pièce ou pour changer la configuration de l'appareil. Ces opérations de montage, de nettoyage et de maintenance doivent être effectuées par des personnes adultes et compétentes.

Cet aspirateur ne convient pas à l'aspiration de substances dangereuses, explosives, ou pouvant présenter un risque biologique. Pour de telles applications spécifiques, contacter votre distributeur qui pourra vous proposer la fourniture d'un équipement adapté.

Cette machine n'est pas un jouet, elle doit être maintenue hors de portée des enfants.

Cet appareil ne doit pas être utilisé par des personnes aux facultés sensorielles, physiques ou mentales réduites. Les personnes inexpérimentées ou non instruites doivent être formées ou supervisées pour l'utilisation de cet appareil.

Vous devez veiller que le cordon d'alimentation n'entre pas en contact avec un objet blessant ou coupant, ou avec les brosses rotatives (dans le cas échéant).



Cet appareil ne convient pas pour être stocké et utilisé à l'extérieur, ou en environnement humide. Il ne convient pas non plus pour aspirer des substances humides, visqueuses ou liquides.

L'aspirateur à poussières est destiné à un usage et un entreposage intérieur uniquement.

AVERTISSEMENT

Assurez-vous que le système de filtration soit approprié pour la collecte de la poussière aspirée.

NOTA

Ce produit répond aux exigences de la norme CAN / CSA E 60335-2.69.

Cet appareil est destiné à un usage commercial, par exemple pour les hôtels, écoles, hôpitaux, ateliers, surfaces de vente et bureaux.

En cas de défaut de fonctionnement de l'appareil, débrancher la prise avant d'entreprendre toute recherche de panne.

En cas de bouchage ou de baisse de l'aspiration de l'appareil, éteignez celui-ci, débranchez la prise d'alimentation, et vérifiez qu'aucune saleté n'obstrue le capteur (ou la brosse), les tubes ou le flexible de l'aspirateur, nettoyer le filtre et remplacer sac filtrant.

Contrôler le bon état de l'aspirateur après utilisation.

Après raccordement de l'appareil à une alimentation appropriée, le voyant "sous tension" s'allume.



CE QU'IL FAUT FAIRE

- Maintenir votre machine propre.
- Maintenir les filtres propres.

- Utiliser des sacs filtrants d'origine, ceux-ci garantissent les performances et l'état de propreté de votre machine.
- Surveiller la propreté du capteur, des tubes et du flexible.
- Remplacer immédiatement toute pièce usée ou endommagée.
- Examiner régulièrement l'état du cordon d'alimentation. Celui-ci devra être remplacé à la moindre détérioration, par un câble d'origine Numatic et par une personne compétente.
- Remplacer fréquemment le sac filtrant, ne pas attendre la saturation de celui-ci.
- Maintenir l'éventuel filtre de refoulement (s'il y a lieu) propre.
- N'utiliser que les brosses et accessoires d'origine. L'usage d'autres brosses peut affecter la sécurité.



CE QU'IL NE FAUT PAS FAIRE

- NE PAS dérouler le câble brutalement, ou débrancher la prise d'alimentation en tirant sur le câble.
- NE PAS aspirer de substances chaudes ou incandescentes, notamment des cendres ou des mégots.
- NE PAS nettoyer l'appareil à la vapeur, ni par aspersion d'eau ni par immersion.
- NE PAS entreprendre d'opération de maintenance ou de nettoyage sans avoir débranché le câble d'alimentation au préalable.
- NE PAS utiliser cet appareil en environnement humide, ou pour aspirer des substances humides.
- NE PAS entreposer en environnement humide

Schematic Diagram - Schéma électrique

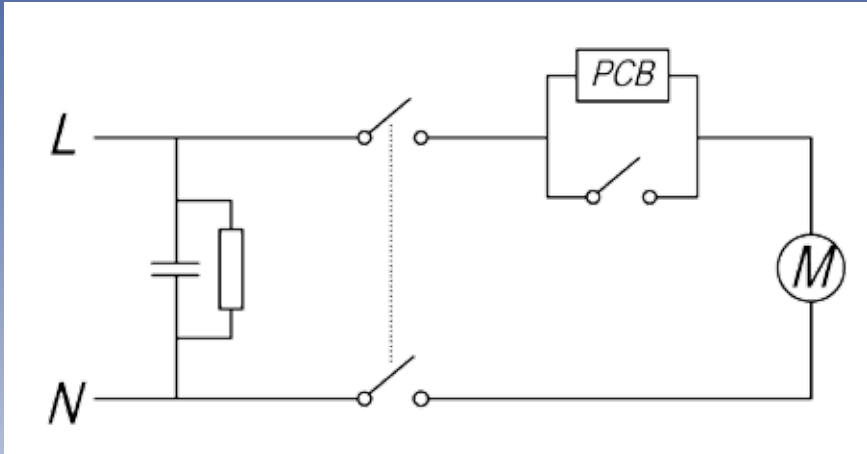

NACECARE

1205 Britannia Road East
Mississauga Ontario L4W 1C7
Canada

Telephone: (800) 387 3210

Fax: (800) 709 2896

<http://www.nacecare.com>



Numatic International Limited, Chard, Somerset, TA20 2GB, ENGLAND.

Telephone 01460 68600 Fax: 01460 68458

www.numatic.co.uk

Specification subject to change without prior notice
www.numatic.co.uk © Numatic International Limited

Specification subject to change without prior notice

www.numatic.com © Numatic International Limited

244103 01/15 (A05)