

GoWISEUSA®

AIR FRYER OVEN DELUXE

USER MANUAL

Model No: GW44800, GW44801, GW44802



Please keep this instruction manual
Please read through this manual carefully before using

⚠ IMPORTANT SAFEGUARDS AND TIPS

TABLE OF CONTENTS

3.....	IMPORTANT SAFEGUARDS
6.....	PARTS AND ACCESSORIES
8.....	CONTROL DISPLAY
9.....	SET UP AND USING Air Fryer Oven
14.....	COOKING PRESET CHART
15.....	INTERNAL TEMPERATURE CHART
16.....	TRUSSING A WHOLE CHICKEN
18.....	ROTISSERIE ROAST A WHOLE CHICKEN
19.....	WARRANTY
21.....	ERROR CODE & TROUBLESHOOTING

IMPORTANT SAFEGUARDS

- **NEVER IMMERSE** the main unit housing in water, as it contains electrical components and heating elements. Do not rinse under the tap.
- **TO AVOID ELECTRIC SHOCK, DO NOT** put liquid of any kind into the main unit housing containing the electrical components.
- This appliance has a polarized plug (one prong is wider than the other). This plug is intended to fit into a polarized outlet only one way. **TO AVOID ELECTRIC SHOCK, DO NOT** force the plug into the outlet if it does not fit. If the plug does not fit fully into the outlet, reverse the plug. If it still does not fit, contact a qualified electrician. **DO NOT ATTEMPT** to modify the plug in any way.
- Always make sure that the plug is inserted into the wall socket properly and without any other appliances on the same outlet.
- To prevent food being in contact with the heating element, **DO NOT OVERFILL** any of the cooking trays.
- **DO NOT COVER OR BLOCK** the air intake vent or air outlet vent while the **GoWISE USA Air Fryer Oven Deluxe** is in operation. Doing so prevents even cooking and may damage the unit or cause it to overheat.
- **NEVER POUR** oil into the square accessory basket. This could result in fire or personal injury.
- While cooking, the internal temperature of the unit reaches several hundred degrees Fahrenheit. **TO AVOID PERSONAL INJURY**, never place hands inside the unit unless it has thoroughly cooled.
- This appliance is **NOT INTENDED FOR USE** by persons with reduced physical, sensory, or mental capabilities or persons with a lack of experience and knowledge unless they are **UNDER THE SUPERVISION** of a responsible person or have been giving proper instruction to use the appliance. This appliance is **NOT INTENDED FOR USE** by children.
- When cooking, **DO NOT PLACE** the appliance against a wall or other appliances. Leave at least five inches of free space along the back, sides, and above the appliance. Do not place anything on top of the appliance.
- **DO NOT USE** this unit if the plug, the power cord, or the appliance itself is damaged in any way.
- **DO NOT PLACE** the unit on stove top surfaces.
- If the power cord is damaged, **YOU MUST HAVE IT REPLACED** by the manufacturer, its service agent, or similarly qualified person to avoid hazard.

IMPORTANT SAFEGUARDS

- Keep the appliance and its power cord **OUT OF THE REACH** of children when it is in operation or during the cooling process.
- **KEEP THE POWER CORD AWAY** from hot surfaces. **DO NOT PLUG** in the power cord or operate the unit controls with wet hands.
- **NEVER CONNECT** this appliance to an external timer switch or separate remote control system.
- **NEVER USE** this appliance with an extension cord of any kind.
- **DO NOT OPERATE** the appliance on or near flammable materials, such as tablecloths and curtains.
- **DO NOT USE** the **GoWISEUSA Air Fryer Oven Deluxe** for any purpose other than described in this manual.
- **NEVER OPERATE** the appliance unattended.
- **KEEP YOUR HANDS AND FACE** at a safe distance from the air outlet vent, as hot air is released through it while in operation. Also, avoid the vent while removing the square accessory basket from the appliance. The unit's outer surfaces may become hot during use. **USE OVEN MITTS** or use the rotisserie tongs when handling hot components. Always use oven mitts when handling hot objects and surfaces.
- Should the unit emit black smoke, **UNPLUG IMMEDIATELY** and wait for smoking to stop before removing oven contents.
- When the time has run out during a cooking cycle, cooking will stop, but the fan **WILL CONTINUE RUNNING** for 20 seconds to cool down the unit.
- Always operate the appliance on a horizontal surface that is level, stable, and noncombustible.
- If the **GoWISE USA Air Fryer Oven Deluxe** is used improperly, for professional or semi-professional purposes, or if it is not used according to the instructions in this user manual, the warranty becomes invalid, and the manufacturer will not be held liable for damages.
- Always unplug the appliance after use.
- Let the appliance cool down for approximately 30 minutes before handling, cleaning, or storing.
- Make sure the ingredients prepared in this unit come out cooked to golden-yellow color rather than dark brown. Remove burnt remnants.
- This appliance is intended for normal household use only. It is not intended for use in commercial or retail environments.

IMPORTANT SAFEGUARDS

- Please note that this unit is constantly emitting heat through the air vents, the unit must be placed on a heat resistant surface. We recommend using a silicone mat or board to protect your counter tops.

Important

- Before initial use and after subsequent use, hand wash all included accessories. Wipe the outside and inside of the Unit with a warm moist cloth and mild detergent. Preheat the Unit for a few minutes to burn off any residue.
- NOTE: The cook-top may smoke the first time it is used. It is not defective, and the smoke will burn off within a few minutes.

Overheating Protection

Should the inner temperature control system fail, the overheating protection system will be activated, and the unit will not function. Should this happen, unplug the power cord. Allow time for the unit to cool completely before restarting or storing.

Electric Power

If the electrical circuit is overloaded with other appliances, your unit may not operate properly. It should be operated on a dedicated electrical circuit.

Automatic Shut-Off

The appliance has a built-in shut-off device which will automatically shut down the unit when the timer LED reaches zero. You can manually switch off the appliance by selecting the power button. The fan will continue running for about 20 seconds to cool down the unit.

Electromagnetic Fields

This appliance complies with all standards regarding electromagnetic fields. According to the instructions in this manual, the appliance is safe to use based on scientific evidence available today if handled properly.

**SAVE THESE INSTRUCTIONS
FOR HOUSEHOLD USE ONLY.**

PARTS AND ACCESSORIES

1. Top Air Intake Vent
2. Control Display
3. Side Air Intake Vents
4. Unit Housing
5. Power Cord + Plug
6. Internal Heating Compartment
7. Oven Door
8. Air Outlet Vent

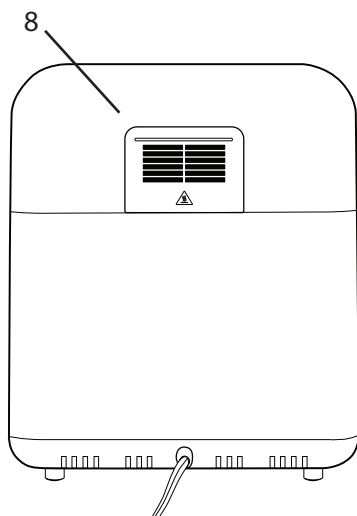
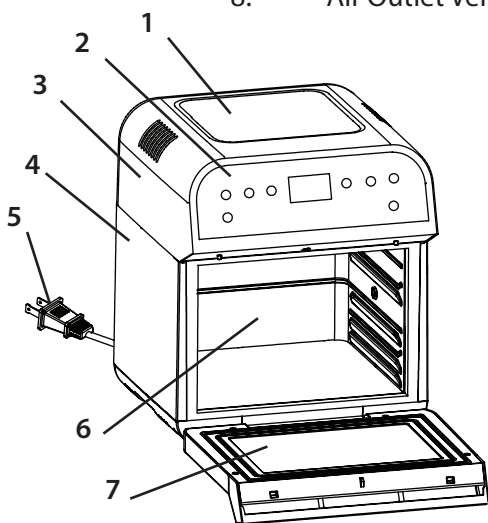

Unit Dimensions:
Outside: 12.4 x 13.1 x 14.5in
Inside: 10.4 x 9.8 x 7.2in

MAKE SURE THE UNIT RESTS ON A FLAT LEVEL SURFACE 5 INCHES AWAY FROM ANY OTHER WALL OR APPLIANCE AND WELL AWAY FROM ANY CURTAINS, FABRICS, OR CLOTHS.

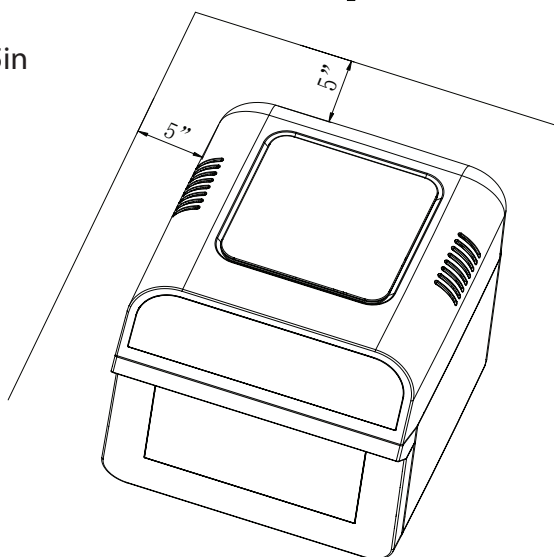

PARTS AND ACCESSORIES

1. Rotisserie Tong
2. Rotisserie Rod
3. Oven Rack
4. Drip Pan
5. Skewer Rotisserie
6. Rotisserie Cage
7. Rotisserie Steak Cage
8. Shallow Mesh Basket
9. Mesh Tray X2



1.

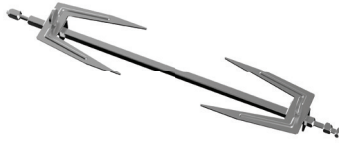

2.

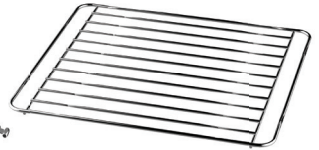

3.



4.

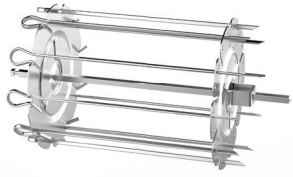

5.



6.

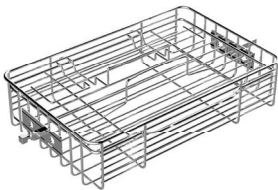

7.

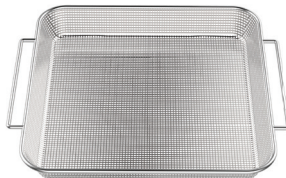

8.

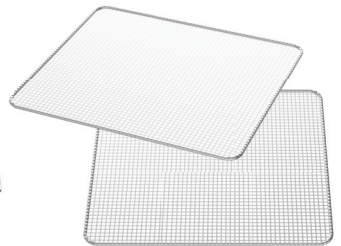

9.

CONTROL DISPLAY

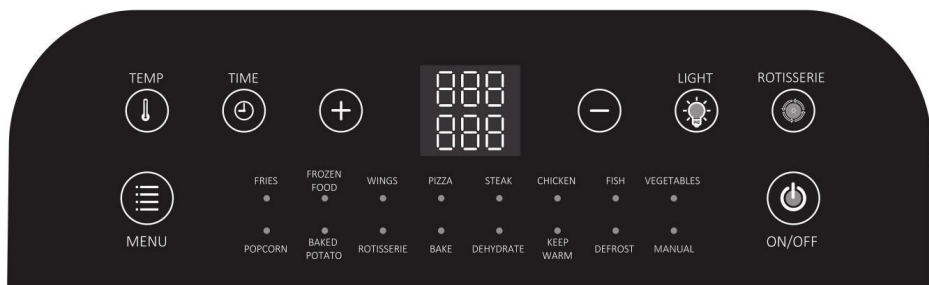

ON/OFF	Powers the Unit ON and OFF STARTS and STOPS cooking process
MENU	Cycle through cooking PRESETS
TEMP	Adjust the temperature of cooking PRESETS
TIME	Increase or decrease cooking TIME
+/- Buttons	Increase or decrease TEMP and TIME
LIGHT	Turn the internal cooking light on or off
ROTISSERIE	Activate the Rotisserie function

**Refer to the PRESET section of this manual (pg.14) for detailed TEMP + TIME for each PRESET*

USING THE DIGITAL CONTROLS

1. Once the Unit is plugged in, the Display Lights will flash once with a single chime/beep.
2. Press the **ON/OFF** button, and the Digital Display will light up displaying zero.
3. Select a preset by pressing the "Menu" button repeatedly until desired cooking preset is reached.
4. To adjust a preset's temperature, press the "Temp" button then press "+" or "-" button to increase or decrease the temperature.
5. To adjust a preset's cooking time, press the "Time" button then press the "+" or "-" button to increase or decrease the cooking time.

NOTE: You can not adjust time and temperature for the "Dehydration" preset.

6. Press the **ON/OFF** button to begin cooking

Note: If using any of the Rotisserie accessories, make sure the Rotisserie function is activated by pressing 'Rotisserie' on the Digital Display before starting the cooking process.

SET UP AND USING Air Fryer Oven

BEFORE FIRST USE

1. Unbox the Unit and place on a counter top or flat surface away from any water source and near a polarized outlet. Before plugging in the Unit, remove accessories from the Internal Heating Compartment. Unwrap accessories.
2. Rinse the accessories with warm water and dry thoroughly. Place the Drip Pan at the bottom of the Air Fryer Oven and close the Air Fryer Oven door.
3. Plug in the Unit. Press the **ON/OFF** button and set the oven to any cooking preset and follow the steps below:
 - a. Press 'Temp' and using the + and – buttons set to 350°
 - b. Press 'Time' and using the + and – buttons set to 05 minutes
4. Wait for the Unit to begin heating
5. This process will burn off any remaining residue left from the manufacturer. There may be a slight burning smell but, will dissipate after a few minutes.
6. Your new **GoWISEUSA Air Fryer Oven Deluxe** is now ready for use!

Inserting the Drip Pan

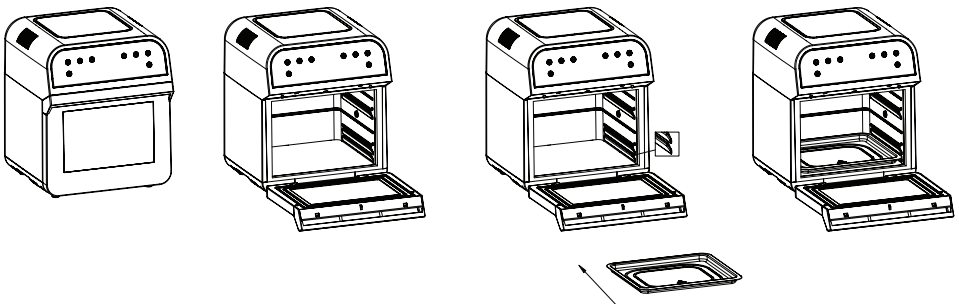

SET UP AND USING Air Fryer Oven

Inserting Wire and Mesh Racks

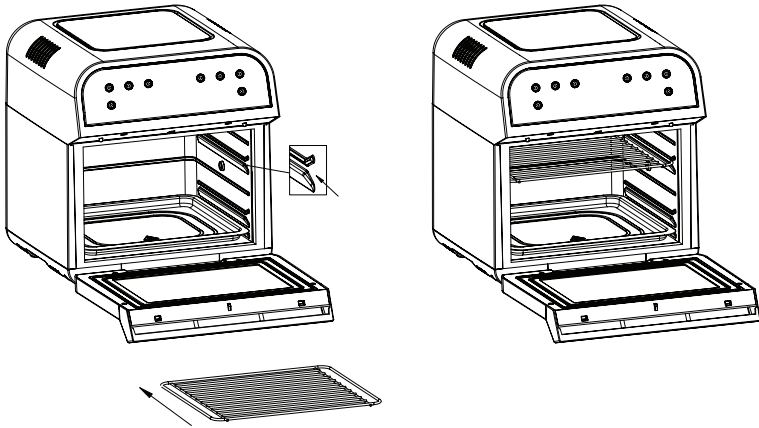

Note:

Choose the correct cooking rack per cooking application. The mesh rack is perfect for dehydration, but is also great for cooking crispy snacks and reheating pizza. The wire rack is best used for holding baking trays at the correct cooking distance from the internal heating element.

CAUTION! Contents and cooking accessories will be extremely hot after every use. To prevent personal injury, always use oven mitts to remove contents and always wait until the Unit has cooled sufficiently before touching or cleaning any area of the Internal Heating Compartment of the Air Fryer Oven.

SET UP AND USING Air Fryer Oven

Rotisserie Skewer: Use for cooking Kebabs.

Attaching Rotisserie Rod and Skewer Racks

1. Place the two Skewer Racks at each end of the Rotisserie Rod. Make sure thumb bolts are on the outer side of the Rotisserie Rod.
2. Slightly tighten the thumb bolts. Do not over tighten as you may need to adjust the tightness after inserting Skewers.
3. Carefully poke Skewers through food.

Rotisserie Skewer Assembly

4. Slide a Skewer into an open slot on the edge of the Skewer Rack with the clip facing toward the Rotisserie Rod.
5. Guide the sharp end of the Skewer through the hole on the opposite Skewer Rack and push the clip through the hole near the slot until the Skewer is secure.
6. Repeat steps 1-2 in a uniform manner around the Skewer Rack. Make sure Skewers are evenly spaced.
7. Tighten thumb bolts to make sure they are securely in place.
8. Use caution when inserting Rotisserie Skewer into the Unit to avoid being poked by the Skewer tips.
9. Open the Oven door. Insert the long end of the Rotisserie Rod into the Rotisserie Socket first then, set the opposite end into the Rotisserie slot. Do not force Rod into the socket, rotate until Rod slips in easily.

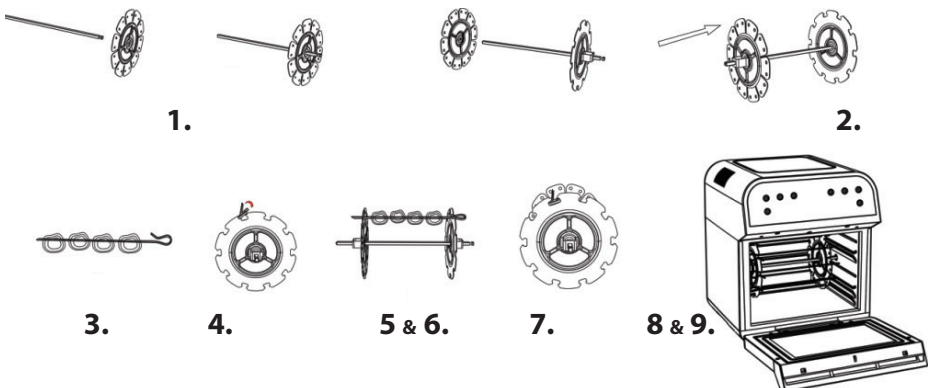

SET UP AND USING Air Fryer Oven

Rotisserie Steak Cage: Use for cooking tender meats like Fish and Steak

1. Open Steak Cage by compressing handles of the Rotisserie Steak Cage and lifting the latch side out first.
2. Place Fish or Steak into the Cage.
3. Replace the Steak Cage lid, make sure the lid is secure and tight against the meat, so it doesn't flop about while the Cage is rotating.
4. Open the Oven door. Insert the long end of the Steak Cage into the Rotisserie Socket first. Then, set the opposite end into the Rotisserie slot. Do not force Rod into the socket, rotate until Rod slips in easily.

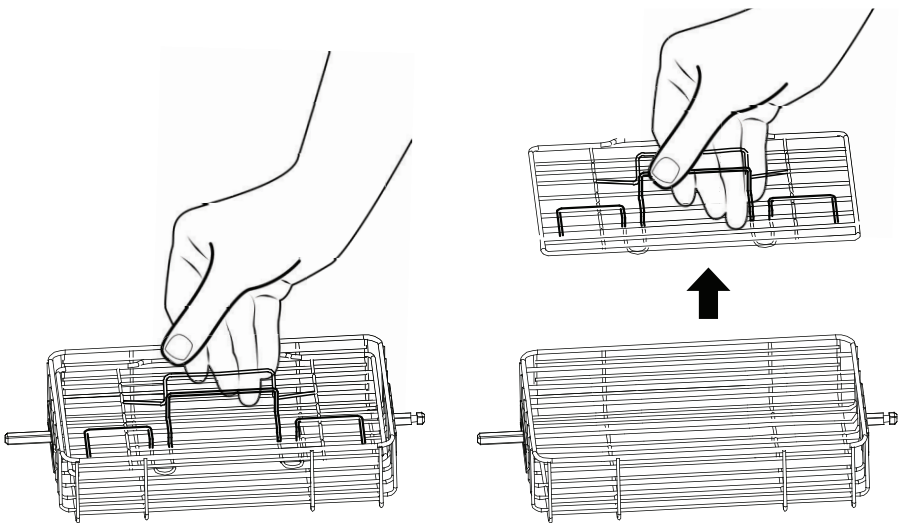

Note: The GoWISE USA Air Fryer Oven Deluxe will only begin heating once the oven door is completely closed. If the oven door isn't completely shut, an alarm will sound when the ON/OFF/START button is pushed.

SET UP AND USING Air Fryer Oven

Removing Rotisserie Skewer, Rotisserie Rod from Unit, and Steak Cage

1. Open the oven door.
2. While wearing oven mitts on both hands and using the Rotisserie Tongs, hook the bottom left and right sides of the Rotisserie Rod, in the gaps of the Rod and carefully lift the Rod out of the resting slot on the left side of the oven – carefully pull the Rod out of the Rotisserie socket and remove from the oven.

Note: Contents will be hot and can easily burn – use caution not to let scalding meat juices or oils from falling on the skin by holding a catch tray or plate under the Rotisserie contents.

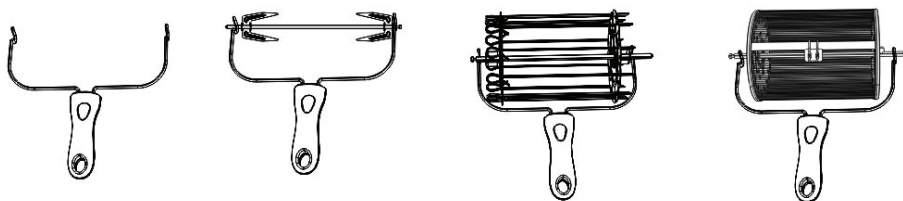

TIP: The Oven Door can be opened during the cooking process – the Unit will stop heating automatically until the door is closed again. The Fan will continue to run while the door remains open. If the Oven Door remains open for 6 minutes, the Unit will shut down.

TO STOP COOKING after the Unit has already started working, press the 'ON/OFF' button once.

Note: If the Unit has been running for any period the Heating Element will be **HOT**, the fan will continue to blow to cool the Heating Element before shutting down completely. However, the Unit will have stopped heating.

CAUTION! Contents and cooking accessories will be extremely hot after any use. To prevent personal injury, always use oven mitts to remove contents and always wait until the Unit has cooled sufficiently before touching or cleaning any area of the Internal Heating Compartment of the Air Fryer Oven.

COOKING PRESET CHART

*Cooking time of a whole roasted chicken may vary depending on weight. Use a meat thermometer to check the internal temperature as per the chart below.

Preset Button	Temperature	Time
Fries	430°	15 min
Frozen food	340°	20 min
Wings	400°	15 min
Pizza	350°	10 min
Steak	400°	12 min
Chicken	430°	25 min
Fish	360°	15 min
Vegetables	400°	10 min
Popcorn	430°	10 min
Baked Potato	400°	40 min
Rotisserie	400°	35 min
Bake	350°	30 min
Dehydrate	130°	8 hr
Keep Warm	150°	30 min
Defrost	120°	30 min
Manual	Optional	Optional

Warning

Never use a cooking vessel filled with cooking oil or any other liquid with this Unit! Fire Hazard or personal injury could result.

INTERNAL TEMPERATURE CHART

This chart should be used to check the temperature of cooked meats. Always review USDA Food Safety Standards.

Food	Type	Internal Temperature
Beef + Veal	Ground	160°F (70°C)
	Steaks, Roasts: Medium	160°F (70°C)
	Steaks, Roasts: rare	145°F (63°C)
Chicken + Turkey	Breasts	165°F (75°C)
	Ground, Stuffed	165°F (75°C)
	Whole bird, legs, thighs, wings	165°F (75°C)
Fish + Shellfish	Any type	145°F (63°C)
Lamb	Ground	160°F (70°C)
	Steaks, Roasts: medium	160°F (70°C)
	Steaks, Roast: Rare	145°F (63°C)
Pork	Chops, Ground, Ribs, Roasts	160°F (70°C)
	Fully cooked Ham	140°F (60°C)

TRUSSING A WHOLE CHICKEN

1. Finding the right size chicken – be careful not use a chicken exceeding the 5lbs max.
2. After preparing, i.e., seasoning the chicken, truss the chicken using butcher's twine.
 - a. Place the chicken on its back with the legs facing toward you.
 - b. Slide a piece of twine under the back of the chicken between the wings and the thighs.
 - c. Pull both ends of the twine up under the chicken's armpits, then pull them over the wings.
 - d. Cross the string around the top of the breast, making sure the skin is secure.
 - e. Bring the ends of the twine back toward you, running them along the sides of the breast above the wings and thighs.
 - f. Cross the ends of the twine, pulling tightly up and under the crown of the bird.

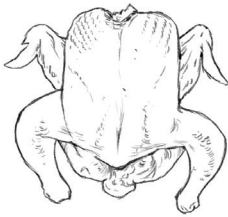

a.



b.

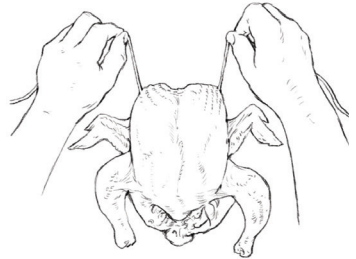

c.



d.



e.

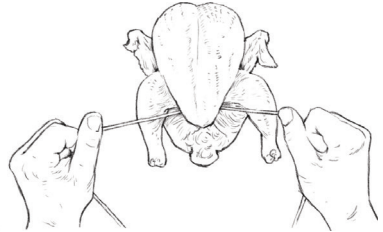

f.

TRUSSING A WHOLE CHICKEN

- g. Loop the ends of the string under the legs, then over the top of the legs. Cross and tighten. The thighs should pop up a little.
- h. Flip the bird onto its belly and finish by tying the strings in a knot around the tail. Snip off the ends.

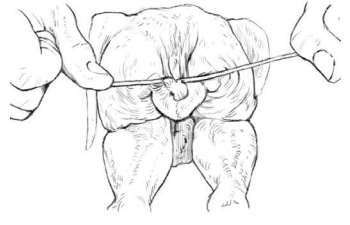
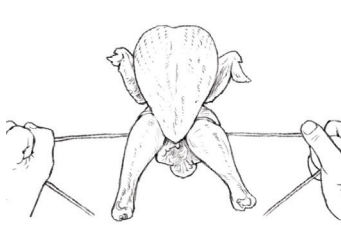
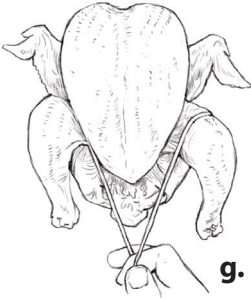

h.



USING THE ROTISSERIE ROD TO ROAST A WHOLE CHICKEN

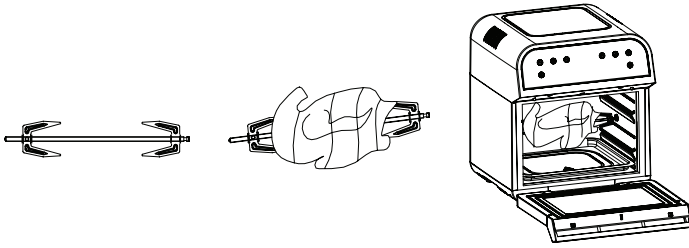

1. After the chicken is trussed, carefully maneuver the Rotisserie Rod through the chicken from the neck to the legs.
2. Slide the Rotisserie Forks on both sides of the Rotisserie Rod piercing the chicken; making sure to secure the chicken in place.
3. Using the Thumb Bolts, lightly tighten the Rotisserie Forks into place – Do not over tighten as removing Rotisserie Forks may become difficult after cooking.
4. Open the Oven door. Insert the long end of the Rotisserie Rod into the Rotisserie Socket first then, set the opposite end into the Rotisserie slot. Do not force Rod into the socket, rotate until Rod slips in easily.
5. Turn the Unit on by pressing ON/OFF and select the Rotisserie 'Preset' by cycling through 'Menu.'
6. Press 'Rotisserie' on the Digital Display to engage the rotation functionality of the Oven.
7. The default cooking temperature and time for Rotisserie is 400° for 35 min – if the chicken is not golden brown and crispy and the internal temperature is not 165°F, repeat the cooking cycle.
8. When the chicken is done cooking with the internal temperature of 165°, remove the chicken using the Rotisserie Tongs.
 - a. Open the oven door.
 - b. While using oven mitts on both hands and using the Rotisserie Tongs, hook the bottom left and right sides of the Rotisserie Rod, in the gaps of the Rod and carefully lift the Rod out of the resting slot on the left side of the oven – carefully pull the Rod out of the Rotisserie socket and remove from the oven.

Note: Contents will be hot and can easily burn – use caution not to let scalding meat juices or oils from falling on the skin by holding a catch tray or plate under the Rotisserie contents.

WARRANTY

General Warranty excludes refurbished / auction items.

GoWISE USA has a 1-year limited warranty for all products. Products are warrantied against defects in materials and workmanship for 1 year from the date of purchase, when used in accordance with the instructions provided. This warranty does not cover damages or wear resulting from accident, misuse, abuse, commercial use, or unauthorized adjustment and/or repair. GoWISE USA shall not be liable for loss of use or any other incidental, consequential or indirect costs, expenses or damages. There are no express warranties except as listed above. This warranty gives you specific legal rights and you may have other rights which vary from state to state.

CALL 855-233-9199 for RETURN INSTRUCTIONS

WE DO NOT SERVICE PRODUCTS OUTSIDE THE 48 CONTINENTAL UNITED STATES. WE WILL SHIP TO A FREIGHT FORWARDER FOR CUSTOMERS.

NOTE: Customers are responsible for all return shipping costs. When item(s) are returned under warranty as being defective, they are thoroughly tested to verify manufacturer defect. If any item(s) are determined to be in proper working order after testing, all shipping cost to have the product returned to the customer will be the responsibility of the customer.

Return Period: 30 Days

All return requests must be made within 30 days from the date our customers purchase their product(s). Refunds are only applicable during the 30-day return period and may be subject to restocking fees up to 15% of the original purchase amount. If the product is defective within 30 days, GoWISE USA will cover the cost of return shipping. However, a photo and/or video from the customer is required to receive a pre-paid shipping label. If the product is missing any accessories that were included in the original

Packaging/shipment, or the product is damaged, altered or used, the item may no longer be eligible for a refund or replacement. Any decision of refund and/or replacement will be decided at the discretion of GoWISE USA.

WARRANTY

NOTE: Customers are responsible for all return shipping costs after 30 days.

Defective/Freight Damaged:

Products that are within the 30-day return period and have been determined by customer service to be defective are qualified for a return label for the product to be returned to GoWISE USA for inspection and testing.

GoWISE USA will provide a return shipping label for defective product(s) only. Customers must contact the carrier (shipping company) for products that have arrived damaged after initial transit. Clear photographic and video proof of damage and/or defective product(s) is REQUIRED prior to GoWISE USA authorizing the return of any product.

Purchase from 3rd Parties:

In order for the GoWISE USA customer service team to lookup the warranty information regarding the product(s), the original order information and/or proof of purchase is required. Without this information, GoWISE USA will be unable to move forward with providing a replacement under warranty, as we do not know the date or origin of the purchase. GoWISE USA does not have a working business relationship with 3rd party selling sites or services or individuals which are not listed below as one of our authorized retailers.

GoWISE USA is not responsible for making inquiries to such 3rd parties for the purpose of obtaining documentation. It is the responsibility of the person(s) making the warranty claim to provide original documentation such as order information and/or a receipt so that customer service can process the request. Any claim made under GoWISE USA warranty guidelines must be made by original purchaser of the product(s). Any defective product(s) will be replaced as long as the issues with the device fall within warranty guidelines.

ERROR CODES & TROUBLESHOOTING

ERROR CODE	ISSUE
E1	Sensor open circuit
E2	Sensors short circuit
E3	Circuit board connection error

If your GoWISE USA Air Fryer Oven displays any of these Error Codes, please contact customer support.

www.gowiseproducts.com
support@gowiseusa.com
855.233.9199

GoWISEUSA®

www.gowiseproducts.com
support@gowiseusa.com
855.233.9199

- To ensure the correct use of this appliance, read these instructions carefully and thoroughly.
- Please keep this manual for future reference.
- Thank you for purchasing this GoWISE USA electric Air Fryer Oven.

USE PROMO CODE: **LIVewisERAF**

**10%
OFF**

YOUR NEXT **GoWISEUSA®** PURCHASE

