

## INSTALLATION INSTRUCTIONS

**CETM-0012** **CETMTM-0091**  
**CETM-0052** **CETMTM-0092**  
**CETM-0081** **CETMTM-0096**



### Notes

**Read this instruction carefully before starting installation.**

Varyify uplevel trim and premium trim before installation.

All mirrors are asymmetrical design for better view range.

For vehicles without factory heat and signal light functions require an additional wiring.

Power fold/Memory/Auto-Dimming functions are not available.

### Step 1A:

#### For uplevel trim w/ door push handle

1. Open the front door to remove the upper extension triangular trim panel.
2. Pry up the push handle cover and remove two 10mm bolts behind.
3. Remove the push handle.
4. Release the door control panel and disconnect the electrical connectors.
5. Pry up the detent tab from the lock rod knob and remove the lock rod (1).
6. Remove the door handle bezel (2) and inner door handle trim panel (3).
7. Remove three 10mm bolts.
8. Remove the door trim panel assembly (5) by pulling the trim away from the door panel to disengage the 12 retainers (6).
9. Disengage the door cable from the retaining clip (7) by pulling it out and away.

## INSTALLATION INSTRUCTIONS

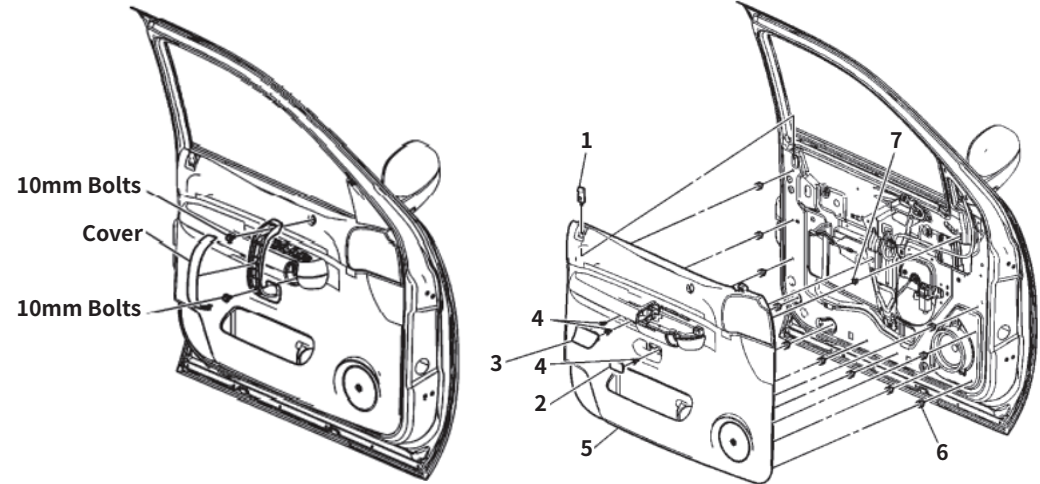

**For uplevel trim w/ door push handle ONLY**

### Step 1B:

#### For premium trim w/o door push handle

1. Open the front door to remove the upper extension triangular trim panel.
2. Release the door control panel and disconnect the electrical connectors.
3. Pry up the detent tab from the lock rod knob and remove the lock rod (1).
6. Remove the door handle bezel (4), and release retainer (3) to remove inner door handle trim panel (2).
7. Remove three 10mm bolts.
8. Remove the door trim panel assembly (6) by pulling the trim away from the door panel to disengage the 12 retainers (8)
9. Disengage the door cable from the retaining clip (7) by pulling it out and away.

## INSTALLATION INSTRUCTIONS

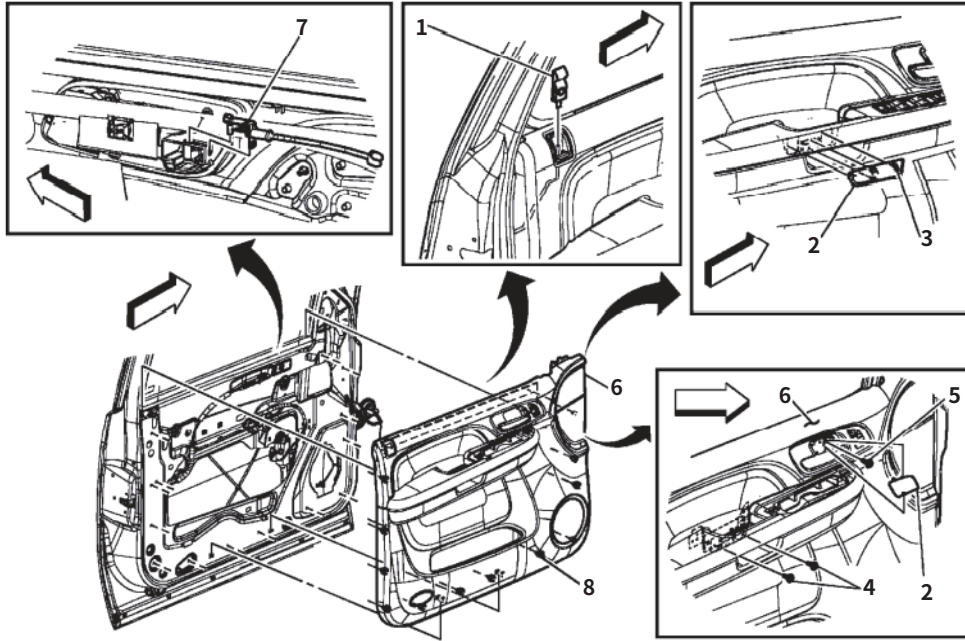

For premium trim w/o door push handle ONLY

### Step 2:

1. Disconnect mirror connector from door harness (**uplevel trim ONLY**).
2. Remove three 10mm hex nuts securing the factory mirror.
3. Carefully remove the factory mirror.

### Step 3:

1. Take the new mirror, feed studs and harness through the existed holes on door panel.
2. Install (3) provided hex nuts to secure the new mirror. Torque to **80 lb in.**
3. Connect mirror connector to door harness (**uplevel trim ONLY**).
4. Connect violet/black harness and feed through door harness tunnel to the engine room.

## INSTALLATION INSTRUCTIONS



### Note:

For uplevel trim, connect the mirror connector to door harness.  
For premium trim, connect the mirror connector to door switch panel.

### Step 4:

1. Repeat above steps on the passenger side.
2. To complete the installation, follow the instructions in the reverse order to reinstall the door trim components.
3. Connect the black wires to the ground pole, violet wires to the trailer backup (TRL B/U) position on fuse box (refer to the owners' s manual).
4. Carefully check all mirrors functions before first drive.
5. For vehicles with memory and tilt functions please disable functions on vehicle' s driver information center.

### Reference Wire Diagram:

See the connector form the wire side.

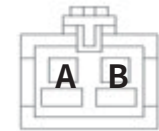
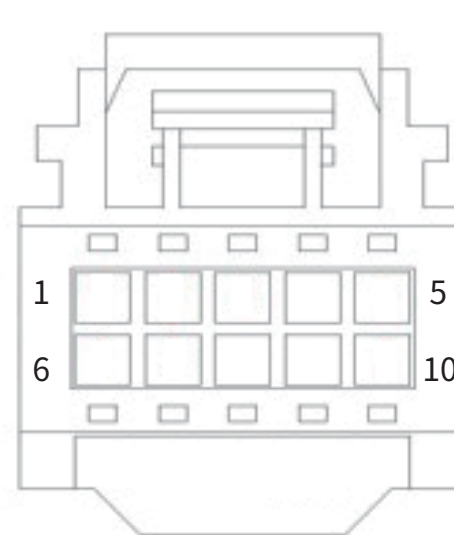

**1/2/6: Mirror Motor**  
**3: Mirror Heater**  
**4: Not Used**  
**5: Signal Light**  
**8-9: Not Used**  
**10: Signal Ground**

**A: Mirror Backup Light**  
**B: Ground**