

## **EN** Operating and installation instructions S Pure

S Pure induction cooktop with integrated cooktop  
extractor – exhaust air/recirculation (PURSA/PURSU)

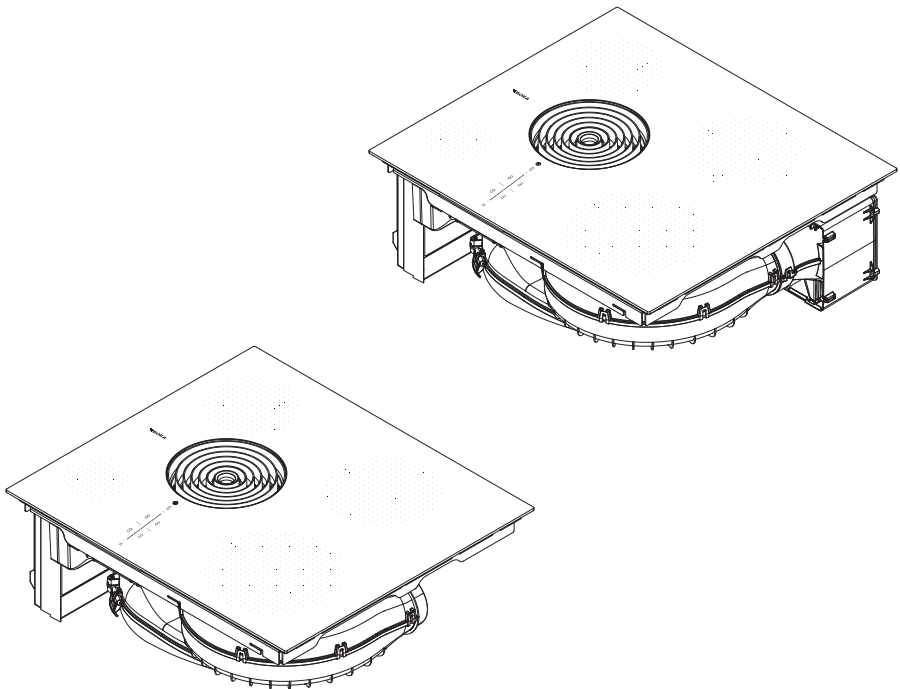

**003284-10002**

[www.bora.com](http://www.bora.com)

# Table of Contents

<b>1</b>	<b>General information</b>	<b>80</b>	<b>6.5</b>	<b>Cooktop functions</b>	<b>104</b>
1.1	Liability	80	6.5.1	Pan size recognition	104
1.2	Validity of the operating and installation instructions	80	6.5.2	Selecting a cooking zone	104
1.3	Product conformity	80	6.5.3	Setting cooking zone power levels	104
1.4	Presentation of information	80	6.5.4	Automatic heat up function	105
<b>2</b>	<b>Safety</b>	<b>82</b>	6.5.5	Cooktop power setting	106
2.1	Use as intended	82	6.5.6	Heat retention function	106
2.2	People with limited abilities	82	6.5.7	Cooking zone timers (automatic cut-off)	106
2.3	General safety instructions	83	6.5.8	Coffee function	107
2.4	Safety instructions for installation	85	6.5.9	Switching off the cooking zone	109
2.5	Safety instructions – operation	87	<b>6.6</b>	<b>Safety features</b>	<b>109</b>
2.6	Safety instructions – cleaning and maintenance	91	6.6.1	Childproofing feature	109
2.7	Safety instructions – repairs, servicing and spare parts	91	6.6.2	control lock	109
2.8	Safety instructions – disassembly and disposal	92	6.6.3	cleaning lock (wipe function)	109
<b>3</b>	<b>Technical data</b>	<b>93</b>	6.6.4	Residual heat indicator	109
3.1	S Pure (PURSA, PURSU)	93	6.6.5	Safety shut-down	110
<b>4</b>	<b>Energy labelling</b>	<b>95</b>	6.6.6	Overheating protection	110
<b>5</b>	<b>Appliance description</b>	<b>96</b>	<b>7</b>	<b>User menu</b>	<b>111</b>
5.1	Model description	96	7.1	Menu item 1:	
5.2	System description	96		Volume of the acoustic signals	112
5.2.1	Structure	96	7.2	Menu item 2:	
5.2.2	Operating panel	96		Childproofing feature	112
5.2.3	Symbols	97	7.3	Menu item 3:	
5.2.4	7-segment display	98		Showing the filter status and resetting filter service display	113
5.2.5	Lighting	98	7.4	Menu item 4:	
5.2.6	Sounds	98		Duration of the automatic after-run function	113
5.3	How the cooktop extractor works	98	7.5	Menu item 5:	
5.4	How the induction cooktop works	99		Touch zone reaction speed	114
5.5	Overview of features and functions	100	7.6	Menu item 6:	
<b>6</b>	<b>Functions and operation</b>	<b>101</b>		LED test	114
6.1	General operating instructions	101	7.7	Menu item 7:	
6.2	Touch control	101		Permanent pan size recognition	115
6.3	Operating the system	101	7.8	Menu item 8:	
6.3.1	Switching on	101		Show software/hardware version	115
6.3.2	Switching off	101	7.9	Menu item 9:	
6.3.3	Electronic power adjustment	102		Safety shut-down	116
6.3.4	Pause function	102	7.10	Menu item A:	
6.3.5	Short-time timer (egg timer)	102		super simple mode	116
6.4	Cooktop extractor functions	103	7.11	Menu item 0:	
6.4.1	Setting the fan power level	103		Reset to factory settings	117
6.4.2	Cooktop extractor power setting	103	<b>8</b>	<b>Cleaning and maintenance</b>	<b>118</b>
6.4.3	Automatic extractor control	103	8.1	Cleaning agents	118
6.4.4	Switching the fan off	103	8.2	Cooktop and extractor care	118
6.4.5	Automatic after-run	104	8.3	Cleaning the cooktop	118
6.4.6	Filter service display	104	8.4	Cleaning the cooktop extractor	119
			8.4.1	Cleaning the air inlet nozzle and stainless steel grease filter	120
			8.4.2	Fitting the components	120
			8.4.3	Removing liquids from the appliance	120

8.5	Cleaning the air guiding housing.....	120	11	<b>Decommissioning, disassembly and disposal</b>	<b>143</b>
8.6	Replacing the activated charcoal filter ....	121	11.1	Decommissioning .....	143
<b>9</b>	<b>Troubleshooting</b>	<b>124</b>	11.2	Disassembly .....	143
<b>10</b>	<b>Installation</b>	<b>126</b>	11.3	Environmentally-friendly disposal .....	143
10.1	General installation instructions .....	126	<b>12</b>	<b>Warranty, technical service, spare parts, accessories</b>	<b>144</b>
10.1.1	Simultaneous operation of the cooktop extractor in the exhaust air mode and a fireplace dependent upon the air supply in the room.....	126	12.1	BORA manufacturer's warranty.....	144
10.2	Scope of delivery .....	127	12.1.1	Warranty extension .....	145
10.3	Tools and aids .....	127	12.2	Service.....	145
10.4	Assembly instructions.....	127	12.3	Spare parts.....	145
10.4.1	Required clearance distances .....	127	12.4	Accessories .....	145
10.4.2	Minimum unit dimensions for S Pure (PURSA, PURSU) .....	128			
10.5	Worktop cut-out.....	128			
10.5.1	S Pure cut-out dimensions (PURSA, PURSU) .....	128			
10.6	Installing the appliance in exhaust air mode (PURSA).....	129			
10.6.1	Preparing kitchen units for the exhaust air model .....	129			
10.6.2	Installation dimensions .....	129			
10.6.3	Preparing the cooktop.....	130			
10.6.4	Inserting the cooktop .....	130			
10.6.5	Connecting the appliance to the duct system .....	131			
10.7	Installing the appliance in recirculation mode (PURSU) .....	132			
10.7.1	Recirculation of air from the kitchen unit ..	132			
10.7.2	Installation variants (A and B) for recirculation appliances .....	132			
10.7.3	Preparing kitchen units for installation variant A (floor unit with continuous back panel).....	133			
10.7.4	Installation dimensions .....	133			
10.7.5	Preparing kitchen units for installation variant B (floor unit with false floor under the cooktop).....	134			
10.7.6	Installation dimensions .....	135			
10.7.7	Preparing the cooktop.....	135			
10.7.8	Inserting the cooktop .....	135			
10.7.9	Making a connection with the back panel (only in installation variant A).....	136			
10.7.10	Inserting the activated charcoal filter .....	137			
10.8	Connecting the power supply.....	138			
10.9	Initial operation.....	140			
10.9.1	Dealer and service menu .....	140			
10.9.2	Function test .....	142			
10.10	Sealing the appliance.....	142			
10.11	Handover to user .....	142			

# 1 General information

These instructions contain important information to protect you from injury and prevent damage to the appliance.

Please read these instructions carefully before installing or using the appliance for the first time.

Other documents apply alongside these instructions. Please by all means adhere to all documents that form part of the scope of delivery.

Assembly, installation and commissioning must always occur in line with national laws, regulations and standards. The work must be performed by qualified specialists who are familiar with and comply with the supplementary regulations of the local utility companies.

All safety and warning information as well as the handling instructions in the accompanying documents must be observed.

## 1.1 Liability

BORA Holding GmbH, BORA Vertriebs GmbH & Co KG, BORA APAC Pty Ltd and BORA Lüftungstechnik GmbH – hereinafter referred to as BORA – does not assume any liability for damage arising from disregard for or non-adherence to the documents included in the scope of delivery!

Furthermore, BORA shall not be held liable for damage caused by improper installation or failure to observe the safety and warning instructions!

## 1.2 Validity of the operating and installation instructions

These instructions apply to several appliance versions. It is therefore possible that some of the features described do not apply to your appliance. The details of the figures contained herein may differ from some appliance versions and are to be understood as schematic diagrams.

## 1.3 Product conformity

### Directives

The appliances meet the following EU/EC directives:  
2014/30/EU EMC Directive  
2014/35/EU Low Voltage Directive  
2009/125/EC Ecodesign Directive  
2011/65/EU RoHS Directive

### Standards

The appliances conform to the following standards:  
IEC 61000-3-12

## 1.4 Presentation of information

We use standard formatting, numbering, symbols, safety instructions, terms and abbreviations so that you can work quickly and safely when using this manual.

The term “appliance” is used to refer to cooktops, cooktop extractors or cooktops with integrated cooktop extractor.

**Instructions** are indicated with an arrow.

► Always follow all instructions in the prescribed order.

**Enumerations** are indicated with a bullet point at the start of the line:

- Enumeration 1
- Enumeration 2

**i** Information notes point to special features that must be taken into account.

## Safety and warning instructions

The safety and warning instructions in this manual are emphasised with symbols and signal words. Safety and warning instructions are structured as follows:

### ⚠ WARNING SYMBOL AND SIGNAL WORD!

#### Type and source of danger

Results of non-compliance

▶ Measures to minimise risk

Please note:

- warning symbols draw attention to a high risk of injury.
- The signal word indicates the severity of that risk.

Warning symbol	Signal word	Risk
	<b>Danger</b>	Indicates an immediate, hazardous situation which causes death or serious injury if not respected.
	<b>Warning</b>	Indicates a potentially hazardous situation which can cause death or serious injury if not respected.
	<b>Caution</b>	Indicates a potentially hazardous situation which can cause minor injury or damage to property if not respected.

**Tab. 1.1** Meaning of the warning symbols and signal words

## Figures

All measurements are provided in millimetres.

## 2 Safety

The appliance complies with the stipulated safety requirements. The user is responsible for the safe use of the appliance, cleaning and maintenance. Improper use can lead to personal injury and damage to property.

### 2.1 Use as intended

The appliance is solely intended for preparing food in private households.

#### **This appliance is not intended for:**

- outdoor use
- heating rooms
- cooling, ventilating or dehumidifying rooms
- use in mobile installation sites such as motor vehicles, ships or aeroplanes
- use with an external timer or a separate remote control system
- use at altitudes of over 2,000 m (metres above sea level)
- use when not fully installed

Any other use or any use that goes beyond that which is described here is classed as unintended.

**i** BORA does not assume any liability for damages caused by incorrect installation, improper use or incorrect operation.

**All misuse is prohibited!**

### 2.2 People with limited abilities

#### **Children**

The appliance can be used by children aged 8 and over if they are supervised or have been instructed how to use the appliance safely and understand the resultant risks. Children must not play with the appliance.

- ▶ Use the childproofing feature in order to prevent children from switching on the appliance or changing the settings when they are unattended.
- ▶ Supervise children in the vicinity of the appliance.
- ▶ Do not store any items that could be of interest to children in storage spaces above or behind the appliance. Otherwise, they will be tempted to climb onto the appliance.

**i** Any work involving cleaning and maintenance must not be carried out by children unless they are supervised at all times while doing so.

### People with reduced physical, sensory or mental capacities

The appliance can be used by people with reduced physical, sensory or mental capacities or a lack of experience and/or knowledge if they are supervised or have been instructed how to use the appliance safely and understand the resultant risks. Operation can be restricted using the childproofing feature.

#### **⚠ DANGER!**

##### **Risk of burns from hot cookware and food**

Handles projecting over the edge of the worktop are asking to be grabbed.

- ▶ Keep children away from hot cooking zones or ensure they are supervised at all times.
- ▶ Do not turn pot and pan handles so they stick out beyond the worktop.
- ▶ Make sure that hot pots and pans cannot be pulled down.
- ▶ If necessary, use suitable stove guards or covers.
- ▶ Only use stove guards and covers that are approved by the appliance manufacturer; otherwise, there is a risk of accidents.
- ▶ To choose a suitable stove guard, contact your specialist supplier or the BORA Service Team.

## 2.3 General safety instructions

#### **⚠ DANGER!**

##### **Packaging components are a choking hazard**

Packaging components (e.g. film, polystyrene) can be life-threatening for children.

- ▶ Store all packaging components out of reach of children.
- ▶ Dispose of the packaging properly and immediately.

#### **⚠ DANGER!**

##### **Risk of electric shock or injury from damaged surfaces**

The underlying electronics can be exposed or damaged due to fissures, fractures or cracks in appliance surfaces (e.g. damaged glass), particularly in the vicinity of the operating unit. This can cause an electric shock. Furthermore, a damaged surface can cause injuries.

- ▶ Do not touch the damaged surface.
- ▶ If there are any cracks, fissures or fractures, switch the appliance off immediately.
- ▶ Safely disconnect the appliance from the mains using the LS switch, fuses, automatic circuit breakers or contactor.
- ▶ Contact BORA Service.

**⚠ WARNING!****Risk of injury or damage due to incorrect components or unauthorised modifications**

Incorrect components can lead to personal injury or damage to the appliance. Modifications, additions or alterations to the appliance can lead to safety risks.

- ▶ Only use original components.
- ▶ Do not make any modifications, additions or alterations to the appliance.

**⚠ WARNING!****Risk of injury due to mechanical damage on the appliance**

Mechanical damage (e.g. cracks, deformation, separation of adhesive seals, etc.) to the appliance, as well as to cables and accessories can cause injuries.

- ▶ Do not operate the appliance.
- ▶ Try not to repair or replace damaged components yourself.
- ▶ Contact BORA Service.

**CAUTION!****Appliance components can cause injury if dropped**

Appliance components (e.g. pan supports, operating controls, covers, grease filters, etc.) can cause injury if dropped.

- ▶ Place any appliance components that have been removed in a safe place near the appliances.
- ▶ Ensure that no components removed from the appliances can fall on the floor.

**CAUTION!****Risk of injury from heavy lifting**

If not handled correctly, carrying and installing appliances can cause injury to the limbs or torso.

- ▶ If necessary, carry and install the appliance with another person.
- ▶ Use appropriate aids to prevent damage or injury.

**CAUTION!****Damage from improper use**

The appliance surfaces must not be used as work or storage surfaces. This can damage the appliances (particularly in the case of hard and sharp objects). Never use the appliances as work or storage surfaces.

- ▶ Keep hard or sharp objects away from the appliance surfaces.

## Faults and errors

- ▶ In the case of faults and errors in the “Troubleshooting” chapter.
- ▶ In the event of any faults or errors that are not mentioned, switch the appliance off and contact BORA Service.

## Pets

- ▶ Keep pets away from the appliance.

## 2.4 Safety instructions for installation

- i** The appliance must only be installed and assembled by trained specialists who are familiar with and comply with the standard national regulations and supplementary regulations of the local utility companies.
- i** During installation maintain the minimum clearance stated in the “Installation” (“Safety clearances”) chapter.
- i** Work on electrical components must only be conducted by trained electrical personnel.
- i** The appliance may only be installed with the power disconnected.

The electrical safety of the appliance is only guaranteed if it is connected to a protective conductor system that has been installed in line with regulations. Ensure that this basic safety precaution is met.

The appliance must be suitable for the regional voltage and frequency.

- ▶ Check the information on the identification plate and in the event of deviations, do not connect the appliance.
- ▶ Do not connect the appliance to the mains until the duct system has been installed or the recirculation filter has been fitted.
- ▶ Only use the connection cables supplied. Where necessary these are included in the scope of delivery.
- ▶ Do not use the appliance until installation is complete. This is the only way to ensure safe operation.
- ▶ Conduct all work extremely attentively and conscientiously and in accordance with these instructions.
- ▶ Before handing the appliance or system over to the end user, ensure that it has been correctly installed.

**⚡ DANGER!****Risk of electric shock from damaged appliance**

A damaged appliance can cause an electric shock.

- ▶ Check the appliance for visible damage prior to installation.
- ▶ Do not install or connect any damaged appliances.
- ▶ Do not operate any damaged appliances.

### 2.4.1 Safety instructions – cooktop extractor installation

**⚡ DANGER!****Risk of electric shock from incorrect stripping of cables**

Incorrect stripping of the connection cable to external switching devices results in a risk of electric shock.

- ▶ Ensure that the stated stripping lengths are adhered to.

**⚠ WARNING!****Risk of injury due to moving fan wheel**

There is a risk of injury while the fan is turning.

- ▶ Only install the device with the power disconnected.
- ▶ Connect both sides of the fan to the duct system before commissioning.

### Special safety instructions for the planning of extractor systems

**⚡ DANGER!****Risk of smoke inhalation**

When the cooktop extractor is used in exhaust air mode, it draws in air from the room it is installed in and from neighbouring rooms. If there is insufficient air supply, low pressure will occur. When used at the same time as a fireplace that is dependent on the air in the room, noxious gases can be sucked into the living areas from the chimney or outlet shaft.

- ▶ Make sure that there is always a sufficient air supply.
- ▶ Only use reliable, tried-and-tested switching devices, (e.g. window contact switch, low pressure warning device) and have them approved by a qualified expert (certified chimney sweep).

### Ducting connected to wall sleeves

In the case of straight ducting and a distance < 900 mm between the fan and wall sleeve, a safety guard must be provided for (available as an accessory).

## 2.4.2 Safety instructions for cooktop installation

### ⚡ DANGER!

#### Risk of electric shock from incorrect mains connection

Connecting the appliance to the mains incorrectly poses a risk of electric shock.

- ▶ Make sure that the appliance has a fixed connection to the mains voltage.
- ▶ Make sure that the appliance is connected to a properly installed protective conductor system.
- ▶ Make sure that technical equipment is provided to enable all of the appliance's poles to be disconnected from the mains with a contact opening width of at least 3 mm (LS switch and automatic circuit breakers, fuses, contactor).

### ⚡ DANGER!

#### Risk of electric shock from damaged power supply cable

If the power supply cable is damaged (e.g. during installation or by coming into contact with hot cooking surfaces), this can cause an (lethal) electric shock.

- ▶ Make sure that the power supply cable does not become trapped or damaged.
- ▶ Make sure that the power supply cable does not come into contact with hot cooking surfaces.

## 2.5 Safety instructions – operation

- ▶ Do not use the appliance until installation is complete. This is the only way to ensure safe operation.
- ▶ Make sure that the base of the cookware as well as the appliance surfaces are clean and dry.
- ▶ Always lift (do not drag) cookware to prevent scratching and abrasion on the appliance surface.
- ▶ Do not use the appliance as a storage surface.
- ▶ Switch off the appliance after use.

### ⚡ WARNING!

#### Risk of burning from hot appliances

Certain appliances and their exposed parts become hot during use. They should be left to cool down completely after switching off. Touching hot surfaces can cause serious burns.

- ▶ Do not touch hot appliances.
- ▶ Pay attention to the residual heat indicator.

**⚠ WARNING!****Risk of burns due to power cut**

During or after a power cut a cooktop that was previously in operation may still be hot.

- ▶ Do not touch the appliance while it is still hot.
- ▶ Keep children away from the hot appliance.

**⚠ WARNING!****Risk of burning and fire from hot objects**

The appliance and its exposed parts are hot during operation and the cooling phase. Objects in contact with hot appliance components heat up very quickly and can cause severe burns (this particularly applies to metal objects such as knives, forks, spoons, lids or appliance components) or catch fire.

- ▶ Do not place any items on the appliance.
- ▶ Please use suitable accessories (pot holders, oven gloves).

**CAUTION!****Damage caused by hot cookware**

Hot cookware can damage certain components in the appliance.

- ▶ Do not put hot cookware down in the area of the operating panel.
- ▶ Keep hot cookware away from the air inlet nozzle.

## 2.5.1 Safety instructions – cooktop extractor operation

**⚠ WARNING!****Fire risk from flambéing**

While the cooktop extractor is working, it sucks up grease from cooking. Flambéing food can cause the grease to catch fire.

- ▶ Clean the cooktop extractor regularly.
- ▶ Never work with a naked flame while the cooktop extractor is running.

**CAUTION!****Damage caused by objects or paper suctioned in**

Small and light items, such as cleaning cloths made from material or paper, can be suctioned into the cooktop extractor. This can damage the fan or impair the exhaust performance.

- ▶ Do not store any items or paper on the cooktop extractor.
- ▶ Only operate the integrated cooktop extractor with the grease filter fitted.

**CAUTION!****Damage caused by grease and dirt deposits**

Grease and dirt deposits can prevent the cooktop extractor from functioning properly.

- ▶ Never use the cooktop extractor without a correctly fitted stainless steel grease filter.

**Special safety instructions for using the exhaust air mode****⚠ DANGER!****Risk of smoke inhalation**

When the cooktop extractor is used in exhaust air mode, it draws in air from the room it is installed in and from neighbouring rooms. If there is insufficient air supply, low pressure will occur. When used at the same time as a fireplace that is dependent on the air in the room, noxious gases can be sucked into the living areas from the chimney or outlet shaft.

- ▶ Make sure that there is always a sufficient air supply.
- ▶ Only use reliable, tried-and-tested switching devices, (e.g. window contact switch, low pressure warning device) and have them approved by a qualified expert (certified chimney sweep).

**Special safety instructions for using the recirculation mode**

When cooking, additional moisture is released into the ambient air. In recirculation mode, only a slight amount of moisture is removed from the cooking vapour.

- ▶ When using the recirculation mode, ensure a sufficient supply of fresh air, e.g. by opening a window.
- ▶ Ensure a normal and comfortable room climate (humidity of 45 – 60%), e.g. by opening natural ventilation openings or using domestic ventilation systems.
- ▶ After every use in recirculation mode, switch the cooktop extractor to a low power level for about 20 minutes or activate the automatic after-run function.

**2.5.2 Safety instructions – cooktop operation**

- ▶ Do not simply rely on the pan size recognition function on induction cooktops; always switch the appliance off after use.

**⚠ DANGER!****Danger of fire caused by leaving the cooktop unattended**

Oil or fat in the pot can quickly heat up and ignite.

- ▶ Never leave oil or fat to heat up unattended.
- ▶ Never extinguish oil and fat fires with water.
- ▶ Switch off the cooktop.
- ▶ Extinguish the fire using a pan lid or a fire blanket, for example.

**⚠ DANGER!****Danger of explosion caused by flammable liquids**

Flammable liquids in the vicinity of a cooktop can explode and cause serious injury.

- ▶ Do not spray aerosols near the appliance when it is in use.
- ▶ Do not place any flammable liquids in the vicinity of a cooktop.

**⚠ WARNING!****Risk of burns from hot liquids boiling over**

Unattended pans can boil over allowing hot liquids to escape.

- ▶ Keep an eye on pans when cooking.
- ▶ Try not to let them boil over.

**⚠ WARNING!****Risk of burns from hot steam**

Liquid between the cooking zone and the pan base can evaporate and cause burns.

- ▶ Make sure that the cooking zone and the pan base are always dry.

**CAUTION!****Damage caused by sugary and salty foods**

Sugary and salty foods and juices can damage the hot cooking zone.

- ▶ Make sure sugary and salty foods or juices do not get onto the cooking zone while it is hot.
- ▶ Remove sugary and salty foods and juices from the hot cooking zone immediately.

**Special safety instructions for the operation of induction cooktops**

Effect on pace makers, hearing aids and metal implants:

induction cooktops generate a high-frequency electromagnetic field in the area of the cooking zones. The cooking zones may affect pacemakers, hearing aids or metal implants negatively or disturb their function when in close proximity. A reduced function of the pacemaker is unlikely.

- ▶ If in doubt, contact the manufacturer of your medical device, or your doctor.

## 2.6 Safety instructions – cleaning and maintenance

The appliance must be cleaned at regular intervals. Dirt can lead to damage, restriction of functions, or bothersome odours. In the worst case scenario, this can become a hazard.

- ▶ Remove dirt immediately.
- ▶ When cleaning, only use non-abrasive detergents to prevent scratching and abrasion on the surface.
- ▶ When cleaning, ensure that no water penetrates the appliance. Use only a slightly damp cloth. Never spray the device with water. Water penetration can cause damage!
- ▶ Do not use a steam cleaner for cleaning. Steam can cause a short circuit on live parts and thus lead to property damage.
- ▶ Please follow all instructions in the “Cleaning and Maintenance” chapter.

### Special safety instructions for cooktop extractor cleaning and maintenance

- ▶ Keep the ventilation openings in the unit below open and clean.

#### **⚠ WARNING!**

##### **Risk of fire from fat deposits**

The risk of fire can be increased by failure to clean the grease filter properly and on a regular basis, or if the filter change is overdue.

- ▶ Clean and replace the filter at regular intervals.

#### **⚠ WARNING!**

##### **Risk of injury when opening the bottom housing cover**

There is a risk of injury while the fan is turning.

- ▶ Switch off the appliance and disconnect it from the mains before removing covers in the vicinity of the fan.

### Special safety instructions for cooktop cleaning and maintenance

- ▶ Whenever possible, clean the cooktops after every use.
- ▶ Only clean the cooktops when they have cooled down.

## 2.7 Safety instructions – repairs, servicing and spare parts

- i** The appliance must only be repaired and serviced by trained specialists who are familiar with and comply with the standard national regulations and supplementary regulations of the local utility companies.

- i** Work on electrical components must only be conducted by trained electrical personnel.
- ▶ Before any repair work, safely disconnect the appliance from the mains supply.

## **⚡ WARNING!**

### **Risk of injury or damage from improper repairs**

Incorrect components can lead to personal injury or damage to the appliance. Modifications, additions or alterations to the appliance can lead to safety risks.

- ▶ Only use original spare parts for repairs.
  - ▶ Do not make any modifications, additions or alterations to the appliance.
- i** A damaged power supply cable must be replaced by a suitable power supply cable. This may only be done by an authorised member of the After Sales Service team.

## **2.8 Safety instructions – disassembly and disposal**

- i** The appliance must only be disassembled by trained specialists who are familiar with and comply with the standard national regulations and supplementary regulations of the local utility companies.
- i** Work on electrical components must only be conducted by trained electrical personnel.
- ▶ Before disassembly, safely disconnect the appliance from the mains supply.

## **⚡ DANGER!**

### **Risk of electric shock from incorrect disconnection**

Incorrectly disconnecting the appliance from the mains results in a risk of electric shock.

- ▶ Safely disconnect the appliance from the mains using LS switches, fuses, automatic circuit breakers or contactors.
- ▶ Use an authorised measuring device to ensure that there is no power to the appliance.
- ▶ Do not touch exposed contacts on the electronic unit as they may contain residual charge.

### 3 Technical data

#### 3.1 S Pure (PURSA, PURSU)

Parameter	Value
Multiphase supply voltage	380 – 415 V 2N/3N
Single-phase supply voltage	220 – 240 V
Frequency	50 – 60 Hz
Maximum power consumption	7250 W
Fuse protection/ three-phase power supply	3 x 16 A
Fuse protection/ two-phase power supply	2 x 16 A
Fuse protection/ single-phase power supply	1 x 32 A (1 x 20 A/1 x 16 A)
Dimensions (width x depth x height)	580 x 515 x 199 mm
Weight (incl. accessories/packaging)	18,3 kg (PURSA) 20,2 kg (PURSU)
<b>Cooktop</b>	
Surface material	SCHOTT CERAN®
Cooktop power levels	1 – 9, P
Size of front left cooking zone	Ø 95 mm
Front left cooking zone power setting output	400 W 600 W
Size of front right cooking zone	Ø 210 mm
Front right cooking zone power setting output	2300 W 3000 W
Size of rear left cooking zone	Ø 140 mm
Rear left cooking zone power setting output	900 W 1350 W
Size of rear right cooking zone	Ø 175 mm
Rear right cooking zone power setting output	1400 W 2100 W
<b>Cooktop energy consumption (pan size)</b>	
Front left cooking zone (-)	inapplicable
Front right cooking zone (210 mm)	189,3 Wh/kg
Rear left cooking zone (150 mm)	194,2 Wh/kg
Rear right cooking zone (180 mm)	182,5 Wh/kg
Total (average)	188,7 Wh/kg
<b>Exhaust air system (PURSA)</b>	
Cooktop extractor power levels	1 – 9, P
Exhaust air connection	BORA Ecotube
<b>Recirculation system (PURSU)</b>	
Cooktop extractor power levels	1 – 9, P
Size of exhaust opening (W x H)	445 x 137 mm
Maximum activated charcoal filter service life	150 hrs (1 year)

Tab. 3.1 S Pure technical data (PURSA, PURSU)

#### PURSA appliance dimensions

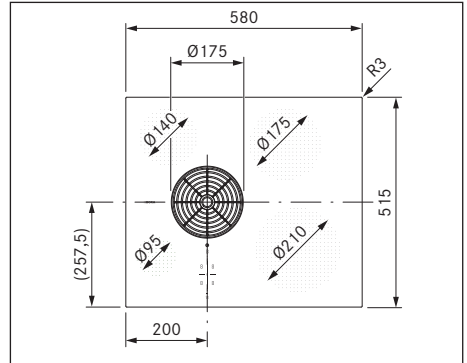

Fig. 3.1 PURSA appliance dimensions top view

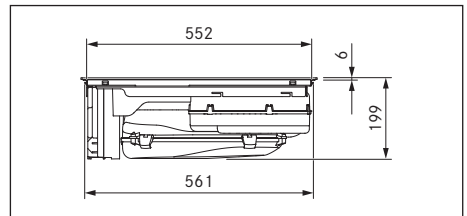

Fig. 3.2 PURSA appliance dimensions front view

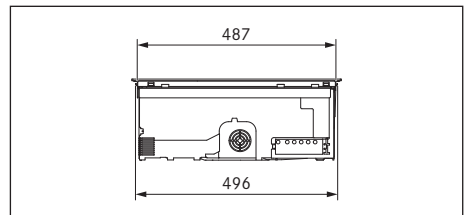

Fig. 3.3 PURSA appliance dimensions side view

## PURSU appliance dimensions

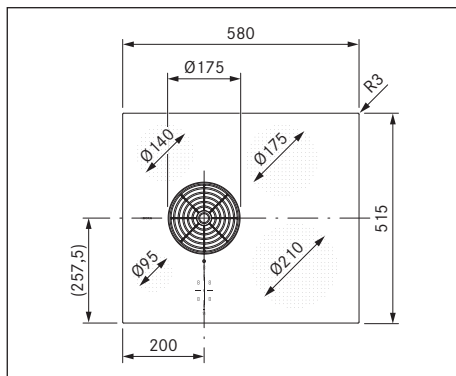

Fig. 3.4 PURSU appliance dimensions top view

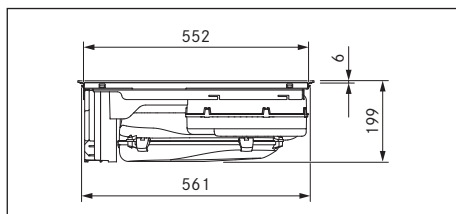

Fig. 3.5 PURSU appliance dimensions front view

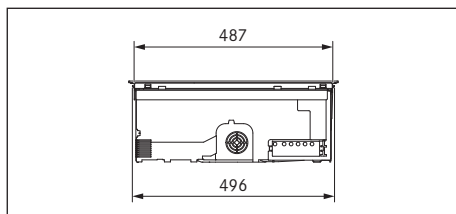

Fig. 3.6 PURSU appliance dimensions side view

## 4 Energy labelling

Product information according to Commission Delegated Regulation (EU) No. 65/2014 and Regulation (EU) No. 66/2014.

Manufacturer	BORA		
Model identification	PURSA		
	Symbol	Value	Unit
<b>Energy consumption</b>			
Annual energy consumption	AEC <sub>hood</sub>	32,4	kWh/a
Energy efficiency class	-	A+	-
Energy efficiency index	EEl <sub>hood</sub>	42,5	-
<b>Flow volume</b>			
Fluid dynamic efficiency	FDE <sub>hood</sub>	33,0	-
Fluid dynamic efficiency class	-	A	-
Minimum air flow in normal use	-	171,6	m <sup>3</sup> /h
Maximum air flow in normal use	-	543,0	m <sup>3</sup> /h
Maximum air flow on intensive or boost setting (power setting)	Q <sub>max</sub>	608,0	m <sup>3</sup> /h
Measured air flow rate at best efficiency point	Q <sub>BEP</sub>	292,4	m <sup>3</sup> /h
Measured air pressure at best efficiency point	P <sub>BEP</sub>	450,7	Pa
Measured electric power input at best efficiency point	W <sub>BEP</sub>	111,0	W
Time increase factor	f	0,8	-
<b>Lighting</b>			
Lighting efficiency	LE <sub>hood</sub>	*	lx/W
Lighting efficiency class	-	*	-
Nominal power of the lighting system	W <sub>L</sub>	*	W
Average illumination of the lighting system on the cooking surface	E <sub>middle</sub>	*	lx
<b>Grease filtering</b>			
Grease filtering efficiency	GFE <sub>hood</sub>	95,2	%
Grease filtering efficiency class	-	A	-
<b>Noise</b>			
Airborne acoustical A-weighted sound power emissions at minimum speed available in normal use	-	39,4	dB(A) re_1 pW
Airborne acoustical A-weighted sound power emissions at maximum speed available in normal use	-	65,5	dB(A) re_1 pW
Airborne acoustical A-weighted sound power emissions on intensive or boost setting (power setting)	-	67,9	dB(A) re_1 pW
Sound pressure level at minimum speed available in normal use**	-	26,4	LpA in dB re 20 µPa
Sound pressure level at maximum speed available in normal use**	-	52,5	LpA in dB re 20 µPa
Sound pressure level on intensive or boost setting (power setting)**	-	54,9	LpA in dB re 20 µPa
<b>Power consumption</b>			
Power consumption in off mode	P <sub>o</sub>	0,14	W
Power consumption in standby mode	P <sub>s</sub>	*	W

Tab. 4.1 Energy labelling

\* Does not apply to this product.

\*\* Voluntary declaration

The sound pressure level has been determined from a distance of 1 m (distance-dependent level recording) on the basis of the sound power level established under EN 60704-2-13.

## 5 Appliance description

Observe all safety and warning information during operation (see „2 Safety“).

### 5.1 Model description

Model	Long description
PURSA	S Pure induction cooktop with integrated cooktop extractor – exhaust air
PURSU	S Pure induction cooktop with integrated cooktop extractor – recirculation

Tab. 5.1 Model description

### 5.2 System description

#### 5.2.1 Structure

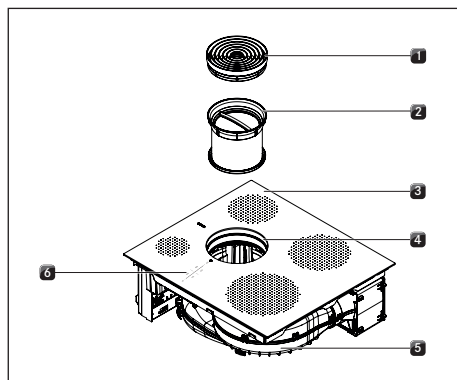

Fig. 5.1 Cooktop

- [1] Air inlet nozzle
- [2] Stainless steel grease filter
- [3] Cooktop
- [4] Inlet opening
- [5] Fan
- [6] Operating panel

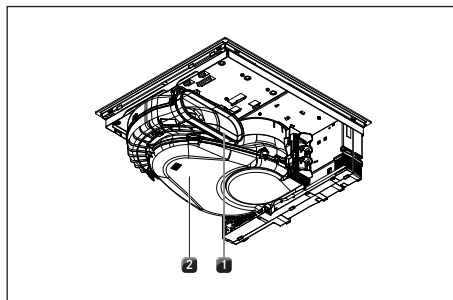

Fig. 5.2 Rear view of PURSA

- [1] Exhaust opening
- [2] Air guiding housing with housing base

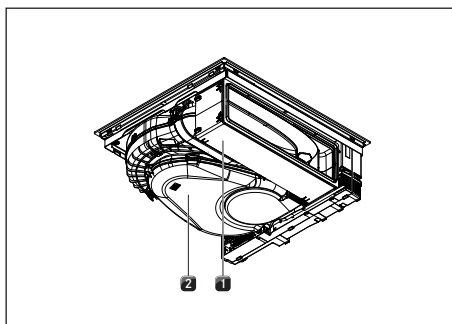

Fig. 5.3 Rear view of PURSU

- [1] Air cleaning box with telescopic pull-out
- [2] Air guiding housing with housing base

#### 5.2.2 Operating panel

The cooktop extractor and cooktops are operated via a central operating panel. The operating panel is fitted with electronic sensor buttons and display panels. The sensor buttons respond to finger contact (touch zones).

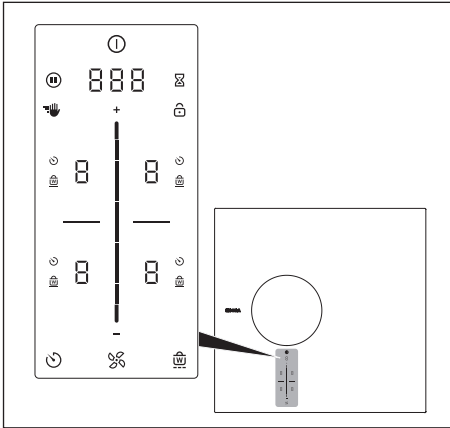

Fig. 5.4 Central touch/slider operating panel

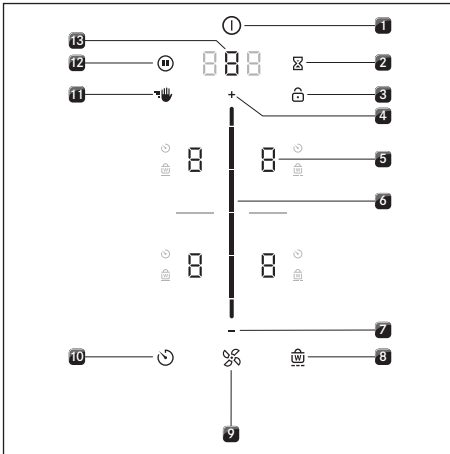

Fig. 5.5 Touch zones/buttons

- [1] Switching on/off
- [2] Short-time timer (egg timer)
- [3] Display lock
- [4] Power level setting zone plus
- [5] Cooking zone selection (x 4)
- [6] Touch slider (power level setting zone)
- [7] Power level setting zone minus
- [8] Heat retention function
- [9] Fan functions
- [10] Cooking zone timer
- [11] Cleaning lock
- [12] Pause function
- [13] Select fan/Call up menu

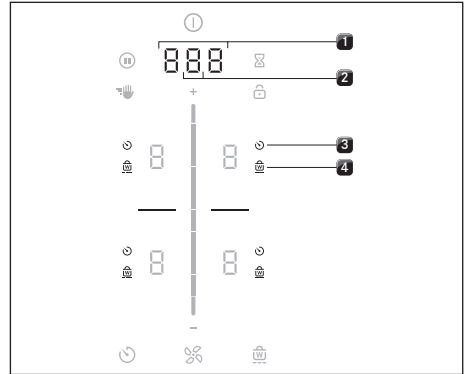

Fig. 5.6 Indicator zones

- [1] Multi-function display
- [2] Fan display
- [3] Cooking zone timer indicator (x 4)
- [4] Warming indicator (x 4)

### 5.2.3 Symbols

Symbols	Description	Function/meaning
	Power button	Switching on/off
	Pause button	Activating/deactivating the pause function
	Cleaning button	Activating/deactivating the cleaning lock
	Egg timer button	Setting the short-time timer (egg timer)
	Lock button	Display lock
	Slider	Setting values
	Plus button	Increasing values
	Minus button	Decreasing values
	Fan button	Activating/deactivating the automatic extractor function, cancelling the after-run function
	Timer button	Setting the cooking zone timer
	Warming button	Activating/deactivating the heat retention function

Tab. 5.2 Meaning of the symbols displayed (icons)

## 5.2.4 7-segment display

Multi-function display	Meaning	
Fan display	- 9	Power levels
	P	Power setting
	□	Inactive
	R	Automatic extractor function
	n	Automatic after-run
	F	Filter service
Multi-function display	□□□	Time indication
	E	Error code
Cooking zone indicator	Meaning	
Cooking zone indicator	- 9	Power level
	P	Power setting
	u	Heat retention level
	☐	Coffee function
	u	Pan size recognition
	□	Inactive
	H	Residual heat indicator (cooking zone is switched off but still hot)
	E	Error

Tab. 5.3 Meaning of the 7-segment displays

## 5.2.5 Lighting

- i** The operating panel has 2 different levels of lighting (100% and 50%).
- i** On principle the system adapts the lighting to the current operating scenario. Relevant display elements are more brightly lit and irrelevant ones are dimmed. Unavailable functions are faded out.

Lighting	Use
100%	Function is active and selected
50%	Function is inactive but can be selected
0% (no indicator)	Function is unavailable

Tab. 5.4 Lighting

## 5.2.6 Sounds

- i** The volume of the acoustic signals can be set in the menu (0% to 100%).
- i** The acoustic signal for the power button cannot be set to 0.
- i** Safety-relevant acoustic signals are always emitted with the volume at 100%.

The system basically differentiates between two different types of acoustic signals:

Acoustic signal	Purpose
Short individual beep (0.1 s)	Confirmation of a selection
Sequence of beeps	Interaction required

Tab. 5.5 Sounds

## 5.3 How the cooktop extractor works

Depending on the model you purchased, the cooktop extractor can be operated as an exhaust air or a recirculating air version.

### Exhaust air mode

The air suctioned away is purified by the grease filter and expelled into the open air via a duct system. The exhaust air must not be expelled into:

- a smoke or exhaust gas flue that is in operation
- a shaft used for the aeration of rooms where fireplaces are installed.

If the exhaust air is to be directed into a smoke or exhaust gas flue that is not in use, the installation must be checked and approved by the responsible heating engineer.



## Recirculation mode

The air suctioned away is purified by the grease filter and an activated charcoal filter and fed back into the room in which the appliance is installed.

To prevent odours in recirculation mode, an odour filter must be used.

For health and hygiene reasons, the activated charcoal filter must be replaced at the recommended intervals (see „8 Cleaning and maintenance“ ).

- i** In recirculation mode, ensure sufficient ventilation and aeration to expel humidity.

## 5.4 How the induction cooktop works

An induction coil is located underneath an induction cooking zone. If the cooking zone is switched on, this coil creates a magnetic field that acts directly on the base of the pot thus heating it up. The cooking zone is only indirectly heated up by the heat emitted by the pot. Cooking zones with induction only work if the cookware has a magnetisable base. Induction automatically takes into account the size of the cookware used which means that only the area in the cooking zone covered by the base of the pot is heated up.

- ▶ Observe the minimum pot base diameter.

### Suitable cookware

- i** The heating and heat-through times for the cookware base, as well as the cooking results, are significantly influenced by the structure and material of the cookware.



Cookware with this symbol is suitable for induction cooktops. The cookware used for the induction cooktop must be made of metal, feature magnetic properties and possess an ample base.

Suitable cookware is made of:

- stainless steel with a magnetisable base
- enamelled steel
- cast iron

Appliance	Cooking zone	Minimum diameter of cookware base
S PURE	left front	70 mm
	left rear	80 mm
	right front	120 mm
	right rear	90 mm

**Tab. 5.6** Minimum cookware diameter

- ▶ Perform a magnet test, if necessary. If a magnet sticks to the base of the utensils, they are normally induction compatible.
- ▶ Pay attention to the cookware base. The bottom of the cookware should not show any sign of curvature. Due to incorrect hob temperature monitoring, this curvature may cause the cookware to overheat. To avoid scratching the cooktop, the base of the cookware must not have any sharp grooves or sharp edges.
- ▶ Place the cookware (without a mat or similar) directly onto the glass ceramic.

### Noises

The following noises may occur in the cookware when using induction cooking zones, depending on the material and the finish of the base:

- Humming may occur when using a high power level. This decreases or disappears when the power level is decreased.
- Crackling or whistling may occur due to the bases of cookware being made of different materials (e.g. sandwich base).
- Clicking sounds may occur during electronic switching procedures, especially at low power levels.
- Whirring may occur when the cooling fan is switched on. In order to increase the service life of the electronic system, the cooktop is equipped with a cooling fan. The cooling fan switches on automatically if the cooktop is used intensively. You will hear a whirring sound. The cooling fan may continue to run after the appliance has been switched off.

## 5.5 Overview of features and functions

The S Pure cooktop with integrated cooktop extractor has the following functions:

- Electronic power adjustment
- Short-time timer (egg timer)

### Cooktop extractor

- Automatic extractor control
- Automatic after-run
- Cooktop extractor power setting
- Filter service display

### Cooktop

- Automatic heat up function
- Pan size recognition
- Permanent pan size recognition
- Heat retention function
- Cooking zone timers (automatic cut-off)
- Pause function
- Cooktop power setting
- Coffee function

### Safety features

- Childproofing feature
- Control lock
- Cleaning lock (wipe function)
- Residual heat indicator
- Safety shut-down
- Overheating protection

 You will find instructions on how to use/set the individual functions in the „6 Functions and operation“ chapter.

# 6 Functions and operation

► Observe all safety and warning information during operation see „2 Safety“.

- i** Do not operate the integrated cooktop extractor with other cooktops.
- i** The cooktop should only be operated when the filter replacement cover, stainless steel grease filter and air inlet nozzle are installed (as well as the activated charcoal filter in the recirculation model).

## 6.1 General operating instructions

The cooktop extractor and cooktops are operated via a central operating panel. The operating panel is fitted with electronic sensor buttons and display panels. The sensor buttons respond to finger contact, see „5 Appliance description“. You operate the appliance by tapping the corresponding sensor button with your finger (touch control) or by a swipe of your finger (slider operation).

## 6.2 Touch control

- i** The system recognises different touch commands. It differentiates between a brief touch (tap), a prolonged touch (long press) and vertical sliding movements with your finger (swiping).

Touch commands	applicable to	Time (contact)
Tap	Buttons + slider	0.3 s
Long press	Buttons + slider	1–8 s
Swipe	Slider	0.1–8 s

Tab. 6.1 Touch control

## 6.3 Operating the system

### 6.3.1 Switching on

- Long press on the power button **ⓘ**
- The switch-on animation is displayed in the slider.
- If start-up is successful, the standard display will appear in the operating panel.

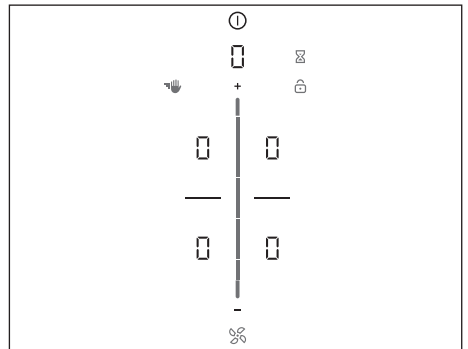

Fig. 6.1 Standard display after switching on

- i** If the childproofing feature is active, the lock button **🔒** will light up after system start-up. The standard display will only appear once it has been unlocked, see „6.6.1 Childproofing feature“.

### 6.3.2 Switching off

- Long press on the power button **ⓘ**
- The switching-off animation is displayed.

#### If the cooktop extractor has been on:

- The fan symbol will light up and the automatic after-run function will start (the automatic after-run animation is displayed).
- The display goes out when the after-run time has lapsed.

**If the cooktop has been on:**

- The residual heat indicator H is displayed for previously active and still hot cooking zones.
- The display goes out when no more residual heat is present.

**6.3.3 Electronic power adjustment**

The power levels are adjusted via the operating panel by tapping or swiping movements on the touch slider. Alternatively the power levels can also be set using the touch buttons **+** and **-** above and below the touch slider.

**6.3.4 Pause function**

With the pause function all cooking zones can be quickly and easily deactivated temporarily. When the function is cancelled, operation resumes at the original settings.

The cooking session can be paused for max. 10 minutes. Once 10 minutes have lapsed, the cooking session is automatically ended.

**Activating the pause function**

- ▶ Tap the pause button 
- The pause button lights up, all cooking sessions are paused and an acoustic signal is heard.
- The cooking zone indicators are dimmed.
- The pause timer is started (max. 10 min).

**i** During the pause, fan function is not interrupted. Egg-timer functions are maintained. Active cooking zone timers are stopped.

**Deactivating the pause function**

- ▶ Long press on the pause button 
- The pause button is dimmed.
- The cooking zone indicators light up.
- All cooking sessions are resumed at the power levels set prior to the pause.
- Active cooking zone timers are resumed.

**6.3.5 Short-time timer (egg timer)**



The short-time timer emits both a visual and an acoustic signal after a time set by the user and provides the function of a conventional egg timer.

**Activating the egg timer**

- ▶ Tap the egg timer button 
- The time flashes in the 7-segment display above the sliders in minutes (□□□).
- The cooking zones in the display are dimmed.

**Setting the time**

- ▶ Select the desired power level:

Command	Increase time	Decrease time
Swipe	 upwards	 downwards
Tap	<b>+</b> (exact to the minute)	<b>-</b> (exact to the minute)

**Tab. 6.2** Setting the time

- The egg timer button  starts to flash.

**Starting the egg timer**

- ▶ Tap the flashing egg timer button 
- The set time starts to count down.
- The operating panel display changes to the standard display and the egg timer button is displayed.

**Time lapsed**

- 10 seconds before the set time lapses, the system flashes the remaining time.
- In the last 5 seconds of the countdown an acoustic signal can be heard every second.
- The time indicator  changes to the fan power level.

**Deactivating the egg timer early**



- ▶ Long press on the egg timer button 
- The egg timer function is ended.
- The operating panel display changes to the standard display.

**i** If the appliance is switched off, the egg timer will remain active.

## 6.4 Cooktop extractor functions

### 6.4.1 Setting the fan power level

The fan power levels can be adjusted in 3 different ways.

- ▶ By tapping a certain position on the slider .
- ▶ By swiping until you reach the required power level.
- ▶ By tapping  or .
- The fan symbol lights up and the set fan power level is shown in the multi-function display.

#### Increasing the power level

- ▶ Tap a higher position on the slider.
- or
- ▶ swipe upwards to the required power level.
- or
- ▶ tap  until the required power level is reached.

#### Reducing the power level

- ▶ Tap a lower position on the slider.
- or
- ▶ swipe downwards to the required power level.
- or
- ▶ tap  until the required power level is reached

### 6.4.2 Cooktop extractor power setting

When the power setting is activated, maximum extractor power is available for a predefined time. This power setting makes it possible to suction away high levels of cooking vapours more quickly. After 5 minutes, the power setting is automatically switched to power level 9.

#### Activating the fan power setting

- ▶ Tap on  when power level 9 is active.
- P appears in the display.

#### Deactivating the fan power setting

The fan power setting is deactivated early if another power level is set.

### 6.4.3 Automatic extractor control

The extractor power level automatically adjusts itself depending on the current cooktop settings. No manual adjustment of the fan controls is necessary but it is possible. The extractor power is automatically adjusted to the highest power level used on all connected cooking zones. If the cooking zone power level is changed, the extractor power is automatically adjusted. The extractor power is adjusted after a 20 second delay.

Function	Power levels									
Cooking level	1	2	3	4	5	6	7	8	9	P
Extractor power	4	4	4	4	5	6	7	8	9	P

Tab. 6.3 Extraction performance and cooking level



#### Activating the automatic extractor function:

- ▶ tap the fan button .
- The fan symbol lights up.
- An animation appears on the slider.
- P is displayed.

#### Deactivating the automatic extractor function:

- ▶ Swipe to a fan power level.
- or
- ▶ tap the fan button .

### 6.4.4 Switching the fan off

- ▶ Swipe downwards to power level 0.
- or
- ▶ tap  until power level 0 is reached.
- or
- ▶ Long press on the fan button .
- or
- ▶ long press on the fan power level in the multi-function display.
- The automatic after-run function is started.

## 6.4.5 Automatic after-run

The cooktop extractor continues to run at a lower level and switches off automatically after a defined time.

The duration of the after-run function can be set in the menu (10, 15 or 20 minutes). The default duration of the after-run function is 20 minutes.

- When the extractor is switched off, the automatic after-run function is activated.
- Once the automatic after-run period has lapsed, the cooktop extractor switches itself off.

**i** BORA expressly recommends use of the cooktop extractor after-run function.

## 6.4.6 Filter service display

The cooktop extractor filter service display is automatically activated when the end of the activated charcoal filter service life is reached (only in recirculation mode).



- The letter F by the front left cooking zone indicator.
- The filter service display is shown every time the cooktop extractor is switched on and remains active until the filter has been changed and the filter service display has been reset (see „7.3 Menu item 3: Showing the filter status and resetting filter service display“).
- The cooktop extractor can still be operated without limitations.

**i** The components of the grease filter require regular cleaning regardless of the filter service display, see „8 Cleaning and maintenance“.

## 6.5 Cooktop functions

### 6.5.1 Pan size recognition

The cooking zone recognises the size of the cookware automatically and only targets the energy at that area. It also recognises cookware that is unsuitable or too small, or if there is no cookware present.

A cooking zone is not working if / are shown alternately in the display. This happens if...

- ...it is switched on without cookware or with unsuitable cookware;
- ...the base diameter of the cookware is too small;
- ...the cookware is removed from a switched-on cooking zone.

If no pot is recognised 10 minutes after setting a power level, the cooking zone will switch off automatically.

### Permanent pan size recognition

The cooking zone automatically recognises cookware and switches the corresponding operating panel on: Manual activation of the cooking zone is not necessary, see „7.7 Menu item 7: Permanent pan size recognition“.

### 6.5.2 Selecting a cooking zone

- ▶ Tap on a cooking zone .
- The cooking zone controls are activated for 2 seconds and you can apply settings to the chosen cooking zone.
- The additional cooking zone functions appear.
- ▶ Repeat this process to operate further cooking zones if necessary.

### Changing to another cooking zone

- ▶ Tap another cooking zone within 2 seconds
- The second cooking zone lights up in the operating panel display and is ready to use.
- The first cooking zone is dimmed in the operating panel display and the previous settings remain active or are adopted.

### 6.5.3 Setting cooking zone power levels

The high power output of induction cooktops results in the very quick heating up of cookware. In order to avoid burning food, slight adjustment is needed in comparison to conventional cooking systems when selecting the power level.

Activity	Power level
Melting butter and chocolate, breaking up gelatine	1
Keeping sauces and soups warm, soaking rice	1 - 3
Cooking potatoes, pasta, soups and ragouts, steaming fruit, vegetables and fish, defrosting food	2 - 6
Frying in coated pans, moderate frying (without overheating the fat) of pork cutlets or fish	6 - 7
Heating up fat, browning meat, cooking thickened sauces and soups, making omelettes	7 - 8
Bringing large amounts of liquid to the boil, searing steaks	9
Heating up water	P

**Tab. 6.4** Recommendations for power levels

The specifications provided in the table are standard values. Depending on the cookware and filling quantity, it is recommended to either decrease or increase the power level.

**i** The cooking zone power levels on the cooktops are shown in the corresponding cooking zone display as a 7-segment font (1 - 9).

**i** Two seconds after the power level is changed, the operating panel display automatically returns to the standard display.

The cooking zone power levels can be adjusted in 3 different ways:

- ▶ By tapping a certain position on the slider.
- ▶ By swiping until you reach the required power level.
- ▶ By tapping **+** or **-**.

#### Increasing the power level

- ▶ Tap the required cooking zone
- ▶ Tap a higher position on the slider.
- or
- ▶ swipe upwards to the required power level.
- or
- ▶ tap **+** until the required power level is reached.

#### Reducing the power level

- ▶ Tap the required cooking zone.
- ▶ Tap a lower position on the slider.
- or
- ▶ swipe downwards to the required power level.
- or
- ▶ tap **-** until the required power level is reached.

### 6.5.4 Automatic heat up function

When the automatic heat up function is activated, the cooking zone works at full power for a certain time and is then automatically reset to the previously set level.

Power level (continuous cooking level)	Cooking duration in min:sec
1	00:40
2	01:00
3	02:00
4	03:00
5	04:20
6	07:00
7	02:00
8	03:00

**Tab. 6.5** Heating time overview

#### Activating the automatic heat up function

- ▶ Tap the required cooking zone
- ▶ Adjusting the power level
- ▶ Long press on the slider **---** at a position lower than power level 9
- The automatic heat up function is activated.
- Whilst the automatic heat up function is active, the power level displayed will flash.
- When the heat up time has ended, the cooking zone will stay on the previously set power level (continuous cooking level).

#### Deactivating the automatic heat up function early

The automatic heat up function is deactivated early if a lower power level is set.

- i** If the power level of a cooking zone is increased when the automatic heat up function is active, the automatic heat up function remains active. The time is restarted for the new continuous cooking level. If the cooking zone power level is decreased while the automatic heat up function is active, the automatic heat up function is deactivated.



## 6.5.5 Cooktop power setting

When the power setting is activated, maximum cooking zone power is available for a predefined time.

- The power setting can be used on all cooking zones at the same time, provided that a restricted operating mode has not been set under the power management setting.
- After 5 minutes, the cooking zone is automatically switched back to the previous power  level.

- i** Never heat up oil, fat and the like on this power setting. The bottom of the pan can overheat due to the high power output.

### Activating the power setting for a cooking zone

- ▶ Tap on  when power level 9 is active.
-  appears in the cooking zone display.

### Deactivating the power setting



The power setting is deactivated early if another power level is set.

## 6.5.6 Heat retention function

The heat retention function enables meals that have already been cooked to be kept warm at a lower temperature without any risk of burning.

- The maximum duration for the heat retention function is preset to 8 hours.

### Activating the heat retention function

- ▶ Tap the required cooking zone
- The additional cooking zone functions appear.
- ▶ Tap the heat retention button 
- The heat retention level is activated.
-  is displayed in the cooking zone display.
- The heat retention symbol  is shown next to the cooking zone.

### Deactivating the heat retention function



- ▶ Tap the required cooking zone
  - ▶ Tap the heat retention button 
- or
- ▶ swipe right down to the bottom (power level 0)
  - The heat retention function is deactivated.
- Selecting a power level also deactivates the heat retention function.

## 6.5.7 Cooking zone timers (automatic cut-off)

The automatic cut-off function automatically switches off the selected cooking zone once a preset time has lapsed. The timer function can also be used on several cooking zones at the same time (multi-timer).





- i** To be able to activate the timer function, a cooking zone power level must first be set.

### Activating cooking zone timers

- ▶ Tap on a cooking zone
- The additional cooking zone functions are displayed.
- If the chosen cooking zone is not yet active (= power level ) a power level can now be set.
- ▶ Tap the timer button 
- The time flashes in the multi-function display above the sliders in minutes ().

### Setting the time

- ▶ Select the desired power level:

Command	Increase time	Decrease time
Swipe	 upwards	 downwards
Tap	 (exact to the minute)	 (exact to the minute)

Tab. 6.6 Setting the time

- The timer symbol  starts to flash.

### Starting the timer

- ▶ Tap the flashing timer button 
- The set time starts to count down.

- The timer symbol  is shown next to the cooking zone.
- The operating panel display changes to the standard display after 2 seconds.
- 10 seconds before the set time lapses, the system flashes the remaining time.
- In the last 5 seconds of the countdown an acoustic signal can be heard every second.

### Showing the remaining time



The cooking zone timer is active and the time counts down:

- ▶ Tap the cooking zone
- The remaining time is shown in the multi-function display.

### Changing active timers

- ▶ Tap a cooking zone with an active timer
- The remaining time is displayed.
- ▶ Tap the timer button 
- The timer is stopped.
- The remaining time flashes in the display.
- The system changes to timer editing mode.
- ▶ Change the set time.
- ▶ Confirm the new set time and start the timer.



### Multi-timer

- ▶ Tap on a different cooking zone
- The additional cooking zone functions are displayed.
- If the chosen cooking zone is not yet active (= power level ) a power level can now be set.
- ▶ Tap the timer button 
- The time flashes in the 7-segment display above the sliders in minutes (.
- Now the time can be set and the timer started.

### Switching the timer off early



- ▶ Tap a cooking zone with an active timer
  - The remaining time is displayed.
  - ▶ Long press on the timer button 
- or
- ▶ long press on the cooking zone with an active timer
  - The timer is switched off.
  - The system switches to the standard display.
  - The cooking zone remains active on the set power level.

### Time lapsed

- 10 seconds before the set time lapses, the system flashes the remaining time.
- In the last 5 seconds of the countdown an acoustic signal can be heard every second.
- The time display  and the timer button 
- After the end of the set time the cooking zone is automatically deactivated (= power level .

## 6.5.8 Coffee function

The coffee function automatically controls the brewing of coffee in an espresso pot.



-  This function can be used in both of the left cooking zones.
-  The espresso pot must be suitable for induction cooktops.

### Setting the water fill quantity of the espresso pot



You must specify the right water quantity to be able to use the coffee function. The following values are provided by default:



Cooking zone	Fill quantity
Front left cooking zone (Ø 95 mm)	210 ml
Rear left cooking zone (Ø 135 mm)	280 ml

**Tab. 6.7** Preset fill quantities for the coffee function

-  Determine the appropriate fill quantity for your espresso pot by filling the bottom chamber with water to just below the safety valve and pouring it into a measuring jug.
-  Set the fill quantity as accurately as possible.
-  You can set a value between 50 and 900 ml.

### Entering the fill quantity

- ▶ Tap the required cooking zone.
- The additional cooking zone functions are displayed.
- ▶ Tap the heat retention button twice 
-  flashes in the cooking zone indicator.
- The set fill quantity is shown for 2 seconds in the fan display and in the slider.
- ▶ Enter the fill quantity:

Entry	Increase quantity	Decrease quantity
100 ml intervals	Swipe upwards	Swipe downwards
10 ml intervals	Tap 	Tap 

**Tab. 6.8** Entering the fill quantity

- ▶ Long press on the indicator .
- The setting is saved and the operating panel switches to the standard display.



-  The setting is saved until another change is made on the appliance.

## Brewing coffee

### Preparing the espresso pot



- ▶ Fill the bottom chamber with cold water to just below the safety valve.
- ▶ Insert the filter funnel.
- ▶ Fill the filter funnel to the brim with ground coffee and level it
  - without pressing down the coffee.
- ▶ Screw the top chamber firmly onto the base.
- Both chambers must be screwed together tightly.
- ▶ Put the espresso pot on the cooking zone.

### Activating the coffee function



- ▶ Tap the required cooking zone.
- The additional cooking zone functions are displayed.
- ▶ Tap the heat retention button twice 
-  flashes in the cooking zone indicator.
- The set fill quantity is shown for 2 seconds in the fan display and in the slider.

### Starting the function

The function can be started as long as the fill quantity is shown in the fan display.

- ▶ Tap the display .
- The remaining time is shown in the multi-function display.
- The operating panel display changes to the standard display after 2 seconds.
- The warming symbol  and the timer symbol  is shown next to the cooking zone.

### Time lapsed

- 10 seconds before the time lapses, the system flashes the remaining time.
- In the last 5 seconds of the countdown an acoustic signal can be heard every second.
- The time indicator  changes to the fan power level.
- After the end of the time, the cooking zone is automatically deactivated (= power level .

### Showing the remaining time

The coffee function is active and the time counts down:

- ▶ Tap the display .
- The remaining time is shown for 2 seconds in the multi-function display.

## Hints and tips

Coffee is ready too early:

- The filled water quantity is too low.
- The set water quantity is too high.
- The ground coffee is too coarse (the coffee may taste watery).
- The filled water is too warm. If no cooler water is available, slightly reduce the set fill quantity.
- The filter funnel is not filled to the brim with ground coffee.

Some of the coffee doesn't run through:



- The filled water quantity is too high.
- The set water quantity is too low.
- The ground coffee is too fine (the coffee may taste bitter).
- The espresso pot wasn't screwed together tightly.
- The filter funnel contains too much coffee or the ground coffee is compressed.

- i** The running time may vary slightly between the two cooking zones.

### 6.5.9 Switching off the cooking zone

- ▶ Tap the required cooking zone.
- ▶ Swipe right down to the bottom until  appears in the cooking zone indicator.

or

- ▶ long press on the cooking zone
  -  is displayed in the cooking zone display.
  - After 2 seconds, the standard display appears.
- or
- ▶ tap  until  appears in the cooking zone indicator.

## 6.6 Safety features

### 6.6.1 Childproofing feature

The childproofing feature prevents the appliance from being switched on accidentally.

- After switching on the appliance, the lock symbol  lights up in the operating panel display.

#### Permanently activating/deactivating the childproofing feature

See „7.2 Menu item 2: Childproofing feature“

#### Deactivating the childproofing feature for a cooking session

- ▶ Long press on the lock button .
- ▶ Swipe downwards
- The standard display lights up and the operating panel is reactivated.

### 6.6.2 control lock

The control lock prevents the current settings from being changed accidentally or without permission.

- If the control lock is active, the symbol lights up .
- The functions are locked and the indicators on the display are dimmed (exception: On/Off touch button).

#### Activating the control lock

- ▶ Long press on the lock button .
- The operating panel display is dimmed.
- The lock button lights up.
- All functions are deactivated except for the power button and the lock button.

- i** If the system is switched off when the control lock is active, the control lock will no longer be active next time the system is switched on.

#### Deactivating the control lock

- ▶ Long press on the lock button .
- The standard display lights up and the operating panel is reactivated.
- The lock button is dimmed.

### 6.6.3 cleaning lock (wipe function)

The cleaning lock prevents settings from being changed when wiping the operating panel during a cooking session. When activated, the operating panel is locked for 10 seconds. The remaining time is displayed. All appliance settings remain unchanged in the meantime.

#### Activating the cleaning lock

- ▶ Tap the cleaning button .
- The cleaning button lights up and all functions on the operating panel are locked for 10 seconds.
- The timer appears in the multi-function display and automatically counts down.

#### Deactivating the cleaning lock

- Once the timer has stopped you can use the functions again.

or

- ▶ Long press on the cleaning button .
- The cleaning button is dimmed.

### 6.6.4 Residual heat indicator

If a cooking zone is still hot after switching off, there is a risk of burns or fire. While H is displayed for a cooking zone (residual heat indicator), do not touch the cooking zone or place any heat-sensitive objects on top of it.

- H shown at 100% brightness: very high temperature.
  - H shown at 50% brightness: high temperature.
- The display goes out after a sufficient cooling time (temperature <55°C).

## 6.6.5 Safety shut-down

### Cooktop extractor

The cooktop extractor switches to automatic mode after 120 min if there has been no input or changes to the power level.

### Cooktops

Each cooking zone is automatically switched off after a predefined operating time in which the power level has not been changed. 3 levels are available to set the time until safety shut-down.

- Safety shut-down is preset to level 2.
- The level can be changed in the user menu.

Power levels	Safety shut-down after hrs:min		
	Level 1	Level 2	Level 3
I	12:00	08:24	06:00
2	10:00	06:24	04:00
3	09:00	05:12	02:30
4	08:00	04:12	02:00
5	06:00	03:18	01:30
6	04:00	02:12	01:00
7	04:00	02:12	01:00
8	03:00	01:48	00:45
9	02:00	01:18	00:30
P	00:05	00:05	00:05

Tab. 6.9 Safety shut-down on the different power levels

Heat retention level	Safety shut-down after hrs:min		
	Level 1	Level 2	Level 3
 TW	12:00	08:00	04:00

Tab. 6.10 Safety shut-down of the different heat retention levels

- ▶ Switch the cooking zone back on if you want to put the cooking zone back into operation.

## 6.6.6 Overheating protection

- i** In the event of overheating, the cooktop power is reduced or the appliance is switched off completely.

The appliance is fitted with overheating protection. The overheating protection can be triggered if:

- cookware is heated up empty;
- oil or fat is heated on high power;
- a hot cooking zone is switched on again after a power cut.

Whilst the overheating protection is active, one of the following steps is taken:

- the activated power setting is switched back to the previous level;
- the power setting P can no longer be switched on;
- the set power level is reduced;
- the cooktop switches off completely.

After a sufficient cooling period, the cooktop can be used again in full.

## 7 User menu

Certain functions can be set in the user menu.

- i** The menu can only be called up if all cooking zones and the cooktop extractor are inactive. In addition, there must be no residual heat.

### Calling up the user menu

- ▶ Switch on the appliance by pressing the power button .
- If start-up is successful, the standard display will appear in the operating panel.
- ▶ Long press on the multi-function display.
- The menu is called up and the first menu item is displayed.

### Navigating the user menu

- ▶ Tap the multi-function display
- The system moves to the next menu item.
- The system automatically adopts and saves set values when you move to another menu item or close the menu.

### Closing the user menu

- ▶ Long press on the multi-function display
- The menu is closed and the standard display appears.

### User menu overview

Menu item/Description/Selection area	Factory setting
1 Volume of the acoustic signals (0–9)	4
2 Childproofing feature (On/Off)	Off
3 Show filter status (reset filter service display)	
4 Duration of the automatic after-run function (10, 15, 20 min.)	20 min
5 Touch zone reaction speed (1 slow, 2 medium, 3 fast)	2
6 LED test	
7 Permanent pan size recognition	Off
8 Software/hardware version	
9 Safety shut-down (1 long, 2 medium, 3 short)	2
A Super simple mode	Off
0 Reset to factory settings	

Tab. 7.1 User menu overview

## 7.1 Menu item 1: Volume of the acoustic signals

- i** In the event of an error message the acoustic signal is always heard at full volume and cannot be changed.
- i** The acoustic signal when switching on or off is always set to at least volume level 4.
- i** The current set volume is shown in the rear, left-hand cooking zone display when the menu item is called up.

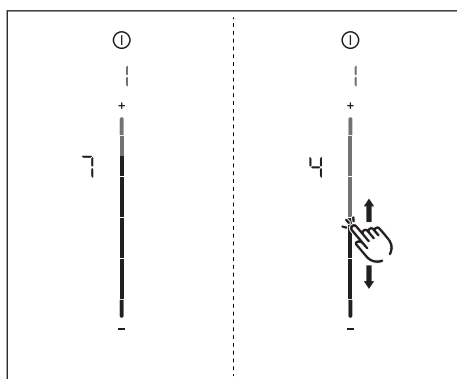



Fig. 7.1 Menu item 1: Volume of the acoustic signals

### Setting the acoustic signal volume:

- ▶ Swipe  upwards or downwards until the required volume is reached.
- ▶ Move to another menu item or close the menu.

## 7.2 Menu item 2: Childproofing feature

- i** With menu item 2 the childproofing feature can be permanently switched on or off. This setting is adopted for each new cooking session.

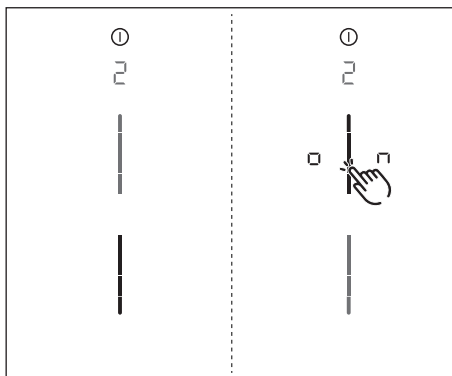





Fig. 7.2 Menu item 2: Childproofing feature

### Permanently activating the childproofing feature

- ▶ Tap the top slider segment 
  -  is displayed.
- ▶ Move to another menu item or close the menu.
- The childproofing feature is permanently activated.

### Permanently deactivating the childproofing feature

- ▶ Tap the bottom slider segment 
  -  is displayed.
- ▶ Move to another menu item or close the menu.
- The childproofing feature is permanently deactivated.

### 7.3 Menu item 3: Showing the filter status and resetting filter service display

- i** If menu item 3 is called up, the filter status will be automatically shown (only in recirculation mode).

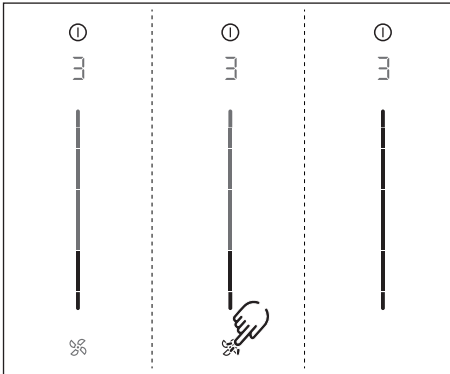



Fig. 7.3 Menu item 3: Filter status

#### Resetting the filter service display:

- ▶ Long press on the fan button .
- All slider elements are once again displayed at 100% brightness.
- The filter service display F no longer appears when the cooktop extractor is switched on.
- ▶ Move to another menu item or close the menu.

### 7.4 Menu item 4: Duration of the automatic after-run function

- i** The duration of the automatic after-run function can be set using menu item 4.

There are three times to choose from:

- 20 minutes
- 15 minutes
- 10 minutes

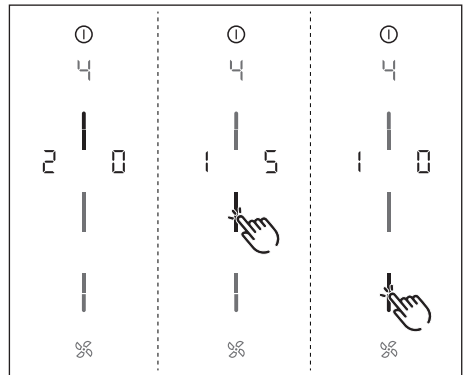



Fig. 7.4 Menu item 4: Duration of the automatic after-run function

- The current duration is displayed for 2 seconds.

#### Selecting the duration of the automatic after-run function:

- ▶ Tap the corresponding slider segment .
- ▶ Move to another menu item or close the menu.

## 7.5 Menu item 5: Touch zone reaction speed

**i** The reaction speed of the touch zones can be set using menu item 5.

- Reaction speed 1: slow
- Reaction speed 2: medium
- Reaction speed 3: fast

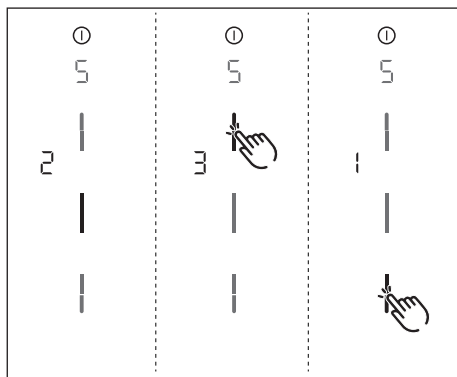



Fig. 7.5 Menu item 5: Reaction speed

- The current reaction speed is displayed.

### Selecting the reaction speed:

- ▶ Tap the corresponding slider segment 
- ▶ Move to another menu item or close the menu.

## 7.6 Menu item 6: LED test

**i** With menu item 6 all LEDs in the individual touch zones can be tested to ensure that they are working.

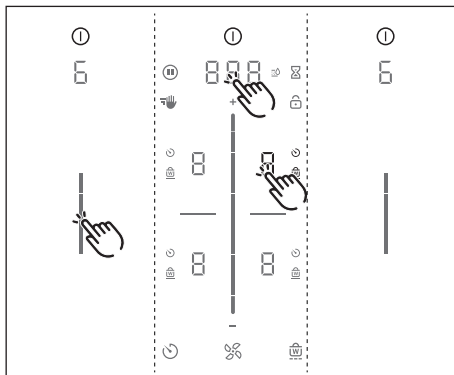



Fig. 7.6 Menu item 6: LED test

### Starting the LED test

- ▶ Tap the slider zone 
- All indicators are displayed at 50% brightness.
- ▶ Tap any indicator you wish.
- The selected indicator will be displayed at 100% brightness for one second.
- Any other indicators can be tested by touch as required.

### Ending the LED test

- The LED test will be automatically ended when there has been no activity for 5 seconds.
- or
- ▶ Long press on the multi-function display.
  - The LED test is ended.
  - ▶ Move to another menu item or close the menu.

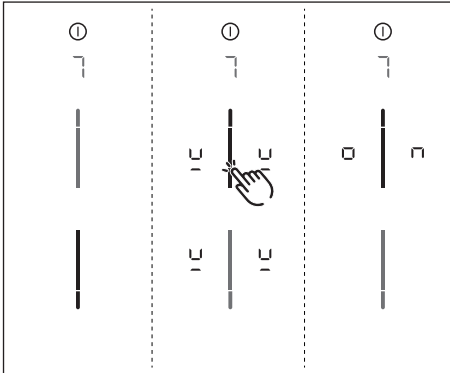

## 7.7 Menu item 7: Permanent pan size recognition

- i** With menu item 7 the permanent pan size recognition can be permanently switched on or off.



**Fig. 7.7** Menu item 7: Permanent pan size recognition

### Activating permanent pan size recognition

- ▶ Tap the top slider segment 
- The pan size recognition symbol  is displayed on all cooking zones for one second.
-  is displayed.
- ▶ Move to another menu item or close the menu.

### Deactivating permanent pan size recognition

- ▶ Tap the bottom slider segment 
- ▶ Move to another menu item or close the menu.

## 7.8 Menu item 8: Show software/hardware version

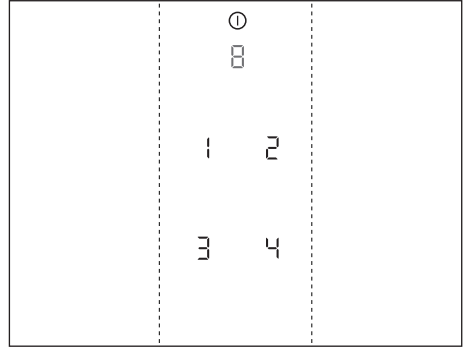

**Fig. 7.8** Menu item 8: Software/hardware version

- The software/hardware version is shown via the four 7-segment cooking zone indicators.
- ▶ Move to another menu item or close the menu.

## 7.9 Menu item 9: Safety shut-down

**i** The time span (level) until automatic safety shut-down of the cooking zones can be selected using menu item 9.

- Level 1: long time span until automatic safety shut-down
- Level 2: medium time span until automatic safety shut-down
- Level 3: short time span until automatic safety shut-down

(see „6.6.5 Safety shut-down“)

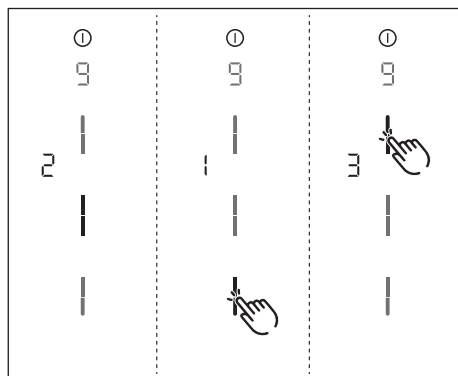



Fig. 7.9 Menu item 9: Safety shut-down

- The current level is displayed.

### Selecting the level:

- ▶ Tap the corresponding slider segment 
- ▶ Move to another menu item or close the menu.

## 7.10 Menu item A: super simple mode

**i** In super simple mode certain additional functions are deactivated and their indicators are faded out.

The following additional functions are deactivated in super simple mode:

- cooking zone timer
- short-time timer (egg timer)
- cleaning lock (wipe function)
- control lock
- heat retention function
- pause function

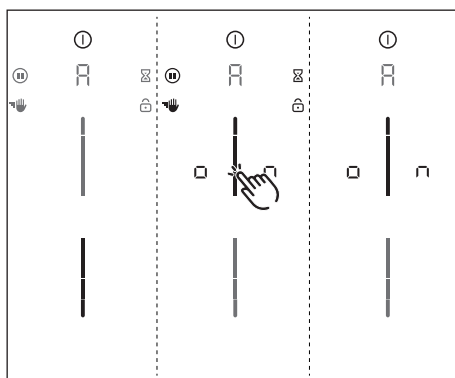



Fig. 7.10 Menu item A: super simple mode

### Activating super simple mode

- ▶ Tap the top slider segment 
- The additional function indicators, which were deactivated, flash and fade.
-  is displayed.
- ▶ Move to another menu item or close the menu.
- The additional functions are permanently deactivated and are not displayed.

## 7.11 Menu item 0: Reset to factory settings

- i** Menu item 0 enables all settings in the user menu to be reset to the factory settings.

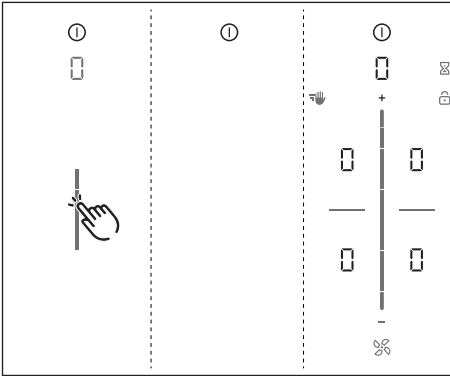



Fig. 7.11 Menu item 0: Factory settings

### Resetting to factory settings

- ▶ Long press on the slider zone 
- The reset is started
- The appliance is restarted.
- The reset is complete when the standard display appears.

## 8 Cleaning and maintenance

- ▶ Observe all safety and warning information (see „2 Safety“).
- ▶ When conducting scheduled cleaning and maintenance, ensure that the cooktop and cooktop extractor are fully switched off and cooled so as to prevent injury (see „6 Functions and operation“).
- Regular cleaning and maintenance ensures long service life of the product and optimal function.
- ▶ Adhere to the following cleaning and maintenance cycles:

Component	Cleaning cycle
Operating panel	Immediately after every soiling
Cooktop	Clean with conventional glass ceramic detergents immediately after soiling and on a weekly basis
Cooktop extractor	weekly
Air inlet nozzle and stainless steel filter	after cooking very greasy dishes; at least once a week, when the fan power level indicator shows F by hand or in the dishwasher (at 65 °C max.); clean stainless steel surfaces in the polishing direction only!
Air guiding housing	Every 6 months or when replacing the activated charcoal filter
Activated charcoal filter (with recirculation only)	replace if odours have built up, extraction power is dwindling or the fan power level indicator shows F

Tab. 8.1 Cleaning cycles

### 8.1 Cleaning agents

- i** Due to the use of aggressive cleaning agents and abrasion caused by the pot bases the surface will become damaged and dark stains will occur.

To clean the cooktop, you need a special glass ceramic scraper and suitable cleaning agents.

- ▶ Never use steam cleaners, abrasive sponges, scouring pads or chemically aggressive cleaning agents (e.g. oven cleaner spray).
- ▶ Make sure that the cleaning agent does not contain any sand, soda, acids, lyes or chloride.

#### For the air inlet nozzle and grease filter

- ▶ Do not use any aggressive cleaning agents or agents containing acid or lye.

### 8.2 Cooktop and extractor care

- ▶ Never use the cooktop as a work or storage surface.
- ▶ Do not push or pull cookware over the cooktop.
- ▶ Always lift pots and pans.
- ▶ Keep the cooktop and extractor clean.
- ▶ Remove any dirt immediately.
- ▶ Only use cookware suitable for glass ceramic cooktops (see „5 Appliance description“).

### 8.3 Cleaning the cooktop

- i** When the cooktop extractor is in use the air inlet nozzle must be fitted so that no small or light objects such as fabric or paper cleaning cloths can be sucked in.

- ▶ Make sure that the cooktop is switched off (see „6 Functions and operation“).
- ▶ Wait until all cooking zones are cold.
- ▶ Remove all coarse dirt and food residues from the cooktop using a glass ceramic scraper.
- ▶ Apply the cleaning agent to the cold cooktop.
- ▶ Spread the cleaning agent using kitchen roll or a clean cloth.
- ▶ Wipe the cooktop clean with a damp cloth.
- ▶ Dry the cooktop with a clean cloth.

#### If the cooktop is hot:

- ▶ Remove stubborn residues of plastic, aluminium foil, sugar or sweet dishes from the hot cooking zone immediately using a glass ceramic scraper to prevent burning.

### Heavy soiling

- ▶ Remove heavy soiling and marks (limescale marks, mother-of-pearl-like shiny marks) using cleaning products while the cooktop is still warm.
- ▶ Wipe off any food that boils over with a damp cloth.
- ▶ Remove any remaining dirt with the glass ceramic scraper.
- ▶ Always remove any seeds, crumbs or similar that fall onto the cooktop during cooking immediately to prevent the surface getting scratched.

Any changes in colour or glossy spots do not mean that the cooktop is damaged. They do not affect the functionality of the cooktop or the stability of the glass ceramic panel.

Changes in the colour of the cooktop are the result of residues which have not been removed and have burnt on.

Glossy spots are the result of wear by the pan base, especially if aluminium-based cookware or unsuitable cleaning agents are used. These are difficult to remove.

## 8.4 Cleaning the cooktop extractor

The air inlet nozzle and stainless steel grease filter absorb the greasy particles from cooking vapours.

- ▶ Make sure that the cooktop and cooktop extractor are switched off (see „6 Functions and operation“).
- ▶ Wait until the fan indicator shows  $\square$  \_
- ▶ Clean the cooktop extractor in accordance with the cleaning cycles.
- ▶ Clean the surfaces of the extraction system using a soft, damp cloth, detergent or a mild window cleaning agent.
- ▶ Soften dried on dirt using a damp cloth (do not scrape it off!).

### Removing the air inlet nozzle

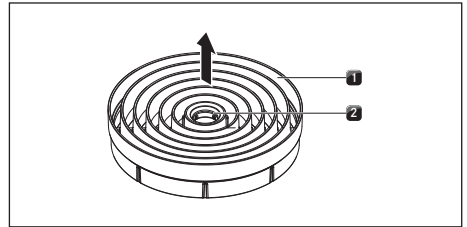

Fig. 8.1 Removing air inlet nozzle

- [1] Air inlet nozzle
- [2] Access opening

#### Prerequisite:

The fan level indicator shows  $\square$  \_

- ▶ Reach into the access opening [2] of the air inlet nozzle [1] with your finger.
- ▶ Pull the air inlet nozzle [1] up and out.

### Removing the stainless steel grease filter

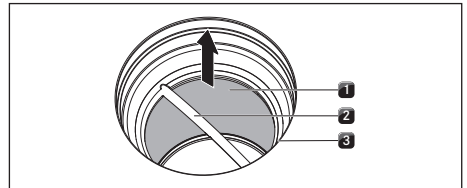

Fig. 8.2 Removing the stainless steel grease filter

- [1] Stainless steel grease filter
- [2] Handle
- [3] Inlet opening

- ▶ Take hold of the stainless steel grease filter by the handle [2].
- ▶ Pull the stainless steel grease filter [1] up and out of the suction opening [3].

### 8.4.1 Cleaning the air inlet nozzle and stainless steel grease filter

- i** If it is no longer possible to clean the stainless steel grease filter completely, it must be replaced (see „12 Warranty, technical service, spare parts, accessories“).

#### Manual cleaning

- ▶ Use a cleaner and degreaser in one.
- ▶ Rinse the air inlet nozzle and stainless steel grease filter with hot water.
- ▶ Use a soft brush to clean the air inlet nozzle and stainless steel grease filter.
- ▶ After cleaning, rinse the air inlet nozzle and stainless steel grease filter well.

#### Cleaning in the dishwasher

- ▶ Remove coarse food residues from the stainless steel filter
- ▶ Rinse the air inlet nozzle and stainless steel grease filter with a rinsing programme at a maximum of 65°C.

- i** To prevent water from dripping into the appliance, it is recommendable to shake the nozzle well upon removal from the dishwasher and, if necessary, to dry it with a tea towel.

### 8.4.2 Fitting the components

#### Inserting the stainless steel grease filter

- ▶ Take hold of the stainless steel grease filter by the handle [2].
- ▶ Insert the stainless steel grease filter [1] in the inlet opening [3]. A lock is not provided or necessary.

#### Inserting the air inlet nozzle

- ▶ Insert the air inlet nozzle in the inlet opening.
- ▶ Make sure it is positioned correctly.

### 8.4.3 Removing liquids from the appliance

Any liquids that flow into the appliance through the inlet opening are caught by the stainless steel grease filter (up to 150 ml) and in the air guiding housing. Do the following:

- ▶ Switch off the fan and deactivate the after-run function (see „6 Functions and operation“).
- ▶ Remove the air inlet nozzle and stainless steel grease filter (see „8 Cleaning and maintenance“).
- ▶ Empty the stainless steel grease filter.
- ▶ Check whether any liquid has gathered in the base of the air guiding housing.
- ▶ If necessary, wipe the liquid up from the housing base from above through the inlet opening using a sponge or cloth.
- ▶ Clean the air guiding housing see „8.5 Cleaning the air guiding housing“.
- ▶ To dry the odour filter and duct parts respectively, switch on the cooktop extractor at a minimum power level of 5.
- After 120 minutes the cooktop extractor will automatically switch to the automatic after-run function (see „5 Appliance description“).

## 8.5 Cleaning the air guiding housing

Grease particles and limescale residues from cooking vapours can settle on the surface of the air guiding housing. For this reason, regular cleaning is essential.

The air guiding housing can be found on the bottom of the cooktop inside the floor unit.

#### Opening the air guiding housing.

- ▶ Make sure that the cooktop and cooktop extractor are switched off (see „6 Functions and operation“).
- ▶ Wait until the fan indicator shows □\_
- ▶ Remove the air inlet nozzle and stainless steel grease filter.
- ▶ Inside the inlet opening pull the filter replacement cover out of the filter housing opening (to remove the filter replacement cover see Fig. 8.4).

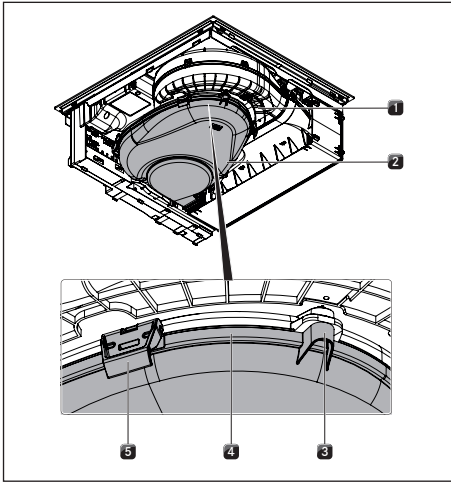

Fig. 8.3 Air guiding housing

- [1] Air guiding housing
- [2] Housing base
- [3] Spigot
- [4] Sealing groove
- [5] Lock

- ▶ Hold the housing base [2] with one hand.
- ▶ Release the 6 locks [5] around the edge of the base.
- ▶ Remove the housing base [2].
- ▶ Clean the air guiding housing [1] and the housing base [2] with a mild cleaning agent.

#### Closing the air guiding housing

- ▶ Position the housing base [2] under the air guiding housing [1] with the help of the 3 spigots [3].
- ▶ Push the housing base [2] upwards into the sealing groove [4].
- ▶ Close the 6 locks [5].
- ▶ Check that the housing base is positioned correctly.
- ▶ Inside the inlet opening push the filter replacement cover until it comes to a stop in the filter housing opening (to insert the filter replacement cover see Fig. 8.10).
- ▶ Check that the filter replacement cover is positioned correctly.
- ▶ Insert the stainless steel grease filter and the air inlet nozzle.

## 8.6 Replacing the activated charcoal filter

An activated charcoal filter will only be fitted with the stainless steel grease filter if the cooktop extractor is used in recirculation mode. The activated charcoal filter absorbs cooking odours that arise during cooking.

**i** The activated charcoal filter must be replaced when the fan indicator shows F (filter service display). You can obtain the activated charcoal filter PUAKF from your specialised retailer or by contacting BORA via the website at [www.bora.com/filter](http://www.bora.com/filter).

- ▶ Make sure that the cooktop and cooktop extractor are switched off (see „6 Functions and operation“).
- ▶ Wait until the fan indicator shows  $\square$ .

#### Removing the activated charcoal filter

- ▶ Remove the air inlet nozzle and stainless steel grease filter.

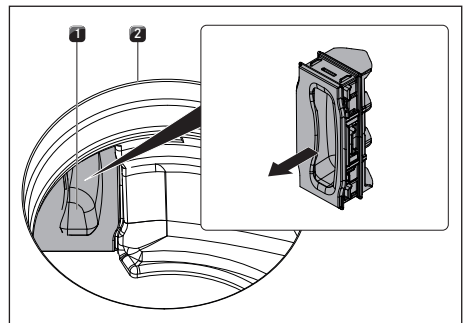
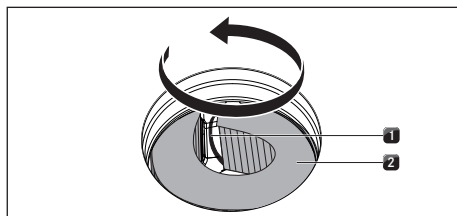

Fig. 8.4 Remove the filter replacement cover

- [1] Filter replacement cover
- [2] Inlet opening

- ▶ Inside the inlet opening [2] pull the filter replacement cover [1] out through the opening in the filter housing.



**Fig. 8.5** Removing the activated charcoal filter from the filter housing

- [1] Grip strap  
[2] Activated charcoal filter

- ▶ Take hold of the activated charcoal filter [2] by the grip strap [1] and pull it out as far as possible through the filter housing opening.

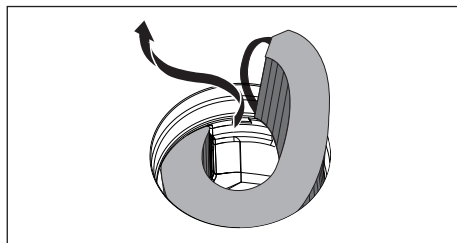

**Fig. 8.6** Removing the activated charcoal filter through the inlet opening

- ▶ Take hold of the end of the activated charcoal filter and pull upwards and towards the left until it is completely out of the inlet opening.

### Inserting the activated charcoal filter

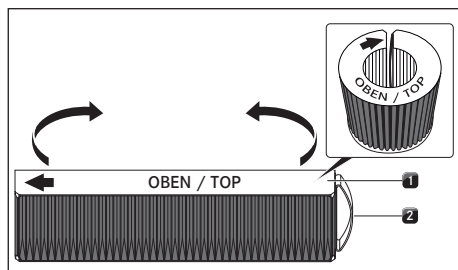

**Fig. 8.7** Activated charcoal filter

- [1] Activated charcoal filter  
[2] Grip strap

- ▶ Remove the packaging from the activated charcoal filter [1].
- ▶ Position the activated charcoal filter correctly with the help of the printed symbols (arrow left, grip strap [2] right).
- ▶ Hold the activated charcoal filter at both ends.
- ▶ Bend the activated charcoal filter into a cylindrical shape so that both ends of the filter are opposite each other.

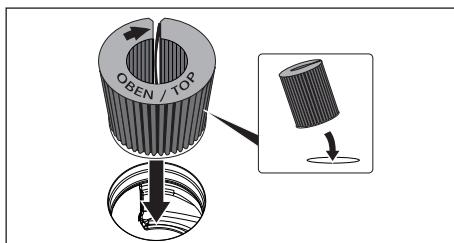

**Fig. 8.8** Inserting the activated charcoal filter through the vent opening

- ▶ Tilt the activated charcoal filter towards you slightly and insert it through the inlet opening.
- ▶ Guide the left end of the filter into the opening in the filter housing.

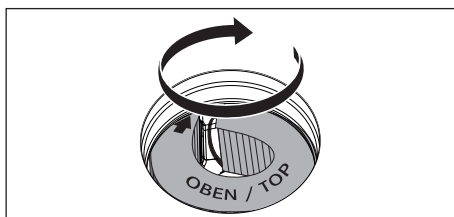

**Fig. 8.9** Placing the activated charcoal filter in the end position

- ▶ Push the activated charcoal filter into the filter housing until it will go no further (to do this, you can place one finger between the slats and gradually push the filter into the housing).
- The end position of the activated charcoal filter is reached when the filter has been fully pushed inside the filter housing.

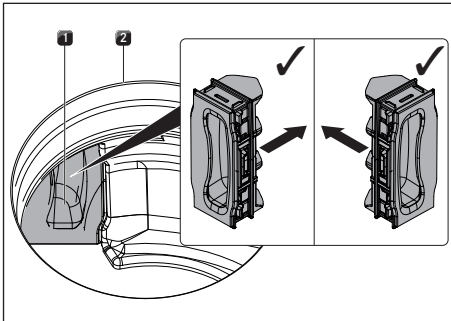

**Fig. 8.10** Inserting the filter replacement cover

[1] Filter replacement cover

[2] Inlet opening

- ▶ Inside the inlet opening push the filter replacement cover until it comes to a stop in the filter housing opening.
- ▶ Check that the filter replacement cover is positioned correctly.
- ▶ Insert the stainless steel grease filter and the air inlet nozzle.
- ▶ Reset the filter status indicator (see „7.3 Menu item 3: Showing the filter status and resetting filter service display“).

## 9 Troubleshooting

**i** You can often resolve faults and errors that can occur in day-to-day operation yourself. That way you save time and money as you don't need to call out customer services.

► Observe all safety and warning information (see „2 Safety“).

Operating situation	Cause	Remedy
The cooktop or the fan cannot be switched on.	The fuse or automatic circuit breaker of the electrical wiring system in the apartment and/or house is defective.	Replace the fuse.  Switch the automatic circuit breaker back on.
	The fuse/automatic circuit breaker trips several times.	Contact the BORA Service Team.
	The power supply is disconnected.	Have a specialist electrician inspect the power supply.
Build-up of odours when new cooktop extractor is in operation.	This is normal on brand-new appliances.	Odours stop forming after a few operating hours.
□ is displayed in the cooking zone display.	No or unsuitable cookware on the cooking zone.	Use suitable cookware. Select the cookware size depending on the cooking zone (see „5.4 How the induction cooktop works“).
The lock symbol is brighter than the other indicators.	The childproofing feature is activated.	Switch off the childproofing feature (see „6.6.1 Childproofing feature“).
A cooking zone or the entire cooktop switches off automatically.	The maximum cooking zone operating time has been exceeded.	Put the cooking zone back into operation.
The power setting is automatically shut off prematurely.	The overheating protection has tripped.	(see „6.6.6 Overheating protection“).
The cooktop cooling fan continues to run when the cooktop has been switched off.	The cooling fan runs until the cooktop has cooled.	Wait until the cooling fan switches off automatically.
The extraction performance of the cooktop extractor has decreased.	The grease filter is extremely dirty.	Clean or replace the grease filter.
	The activated charcoal filter is extremely dirty (with PURSU only).	Insert a new activated charcoal filter (see „8.6 Replacing the activated charcoal filter“).
	There is an object in the air guiding housing (e.g. cleaning cloth).	Remove the object.
E is shown in the fan display.	Home In not authorised.	Open the window.
	The safety device is defective.	Contact the BORA Service Team.
E□ is shown in the cooking zone	The overheating protection has tripped.	See „6.6.6 Overheating protection“.
E□□ is displayed. E in the fan display, □□ in the rear cooking zones.	Object on the operating panel.	Remove the object from the operating panel.
	The operating panel is dirty.	Clean the operating panel.
E□ is shown in the fan display	Use of a phase-separating window contact switch.	Open the window.
	The cooktop extractor is defective or a cable connection has become loose.	Contact the BORA Service Team.
F is shown in the fan display (with PURSU only).	End of activated charcoal filter service life reached.	Insert a new activated charcoal filter (see „8.6 Replacing the activated charcoal filter“).

Tab. 9.1 Resolving a fault

**Faults and errors not covered:**

- ▶ Switch off the appliance.
- ▶ Contact the BORA Service Team (see „12 Warranty, technical service, spare parts, accessories“) and enter the error number displayed and the appliance type.

## 10 Installation

- ▶ Observe all safety and warning information (see „2 Safety“).
- ▶ Follow the enclosed manufacturer's information

### 10.1 General installation instructions

- i** The power supply cable must be provided by the customer.
- i** The appliance must not be installed above cooling devices, dishwashers, stoves, ovens, washing machines or dryers.
- i** The contact surface of the worktops and wall sealing strips must be made of a heat-resistant material (up to approx. 100°C).
- i** Worktop cut-outs must be moisture-sealed using suitable means and, where necessary, fitted with a thermal insulator.
- i** The integrated cooktop extractor must not be used with other cooktops.

#### General installation instructions for cooktops

- i** To ensure that the cooktops perform optimally at all times, there must be sufficient ventilation beneath the cooktops.
  - i** The performance of the cooktops is affected or the cooktops overheat if the warm air beneath the cooktops cannot escape.
  - i** If a cooktop overheats, the power is automatically reduced or the cooktop is switched off completely (see „6.6.6 Overheating protection“).
  - i** If cable protection (false floor) is planned beneath the appliance, this must be fitted so it does not obstruct ventilation.
- ▶ Make sure that the area below the cooktop has a sufficient air supply.

#### 10.1.1 Simultaneous operation of the cooktop extractor in the exhaust air mode and a fireplace dependent upon the air supply in the room

- i** National and regional laws and regulations must be observed with regard to the exhaust duct design.
- i** A sufficient air supply must be ensured

Fireplaces that depend on the air in the room (e.g. gas, oil, wood or coal-fired heaters, continuous-flow water heaters, instantaneous water heaters) draw in air from the room in which they are installed and release the exhaust fumes into the outside air via an exhaust system (e.g. chimney).

If the cooktop extractor is used in exhaust air mode, it draws in air from the room in which it is installed as well as from neighbouring rooms. If there is insufficient air supply, low pressure will occur. Toxic gases could be drawn out of the chimney or extraction ducting and back into the room.

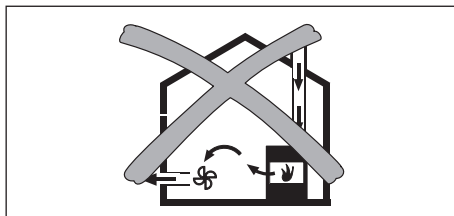

Fig. 10.1 Exhaust air installation – not permitted

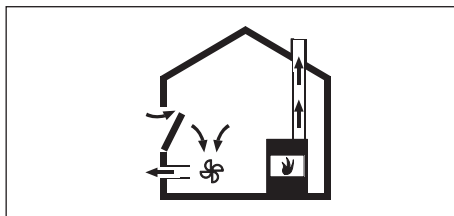

Fig. 10.2 Exhaust air installation – correct

- ▶ If simultaneously operating both a fireplace and the cooktop extractor in the same room, ensure that:
  - the maximum low pressure is 4 Pa (4 x 10–5 bar);
  - a safety device (e.g. window contact switch, low pressure warning device) is used to ensure that a sufficient supply of fresh air is guaranteed;
  - the exhaust air is not channelled into a chimney that is used for exhaust gases of appliances operated with gas or other combustibles;
  - the installation is checked and approved by an authorised certified engineer (e.g. heating engineer).

**i** If the cooktop extractor is used exclusively in recirculation mode, operation with an open fireplace is possible without any additional safety measures.

## 10.2 Scope of delivery

Scope of delivery PURSA, PURSU	Quantity
Cooktop with integrated cooktop extractor	1
Air inlet nozzle	1
Stainless steel grease filter	1
Operating and installation instructions	1
Sealing tape	1
Height adjustment plate set	1
Bag containing various small parts for assembly	1
<b>Additional scope of delivery PURSU</b>	
Activated charcoal filter	1
Template for back panel cut-out	1

**Tab. 10.1** Scope of delivery

### Checking the scope of delivery

- ▶ Make sure the delivery is complete and check it for damage.
- ▶ If there are any missing or damaged parts, please notify the BORA After Sales Service immediately.
- ▶ Do not under any circumstances install parts which are damaged.
- ▶ Dispose of transport packaging in the proper manner (see „11 Decommissioning, disassembly and disposal“).

## 10.3 Tools and aids

The following special tools, among others, are required to correctly install the cooktop:

- compass saw or hand saw
- drilling template for cut-out on back panel PURU (included in scope of delivery)
- Torx 20 screwdriver
- black, heat-resistant silicone sealant

## 10.4 Assembly instructions

### 10.4.1 Required clearance distances

- ▶ Observe the required clearance distances.

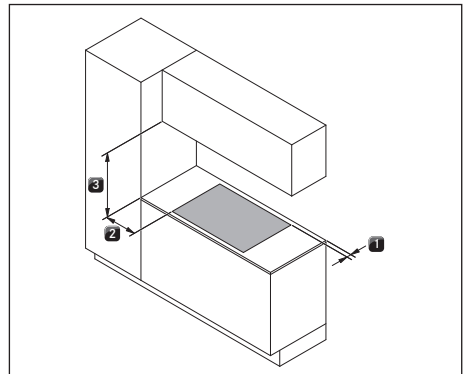

**Fig. 10.3** Required clearance distances

- [1] Minimum clearance of 50 mm between the worktop cut-out and the rear edge of the worktop.
- [2] Minimum clearance of 300 mm from the left and right of the worktop cut-out to the adjacent cabinet or wall.
- [3] Minimum clearance of 600 mm between the worktop and the wall unit. A minimum clearance of 1000 mm is recommended for ergonomic reasons.

## 10.4.2 Minimum unit dimensions for S Pure (PURSA, PURSU)

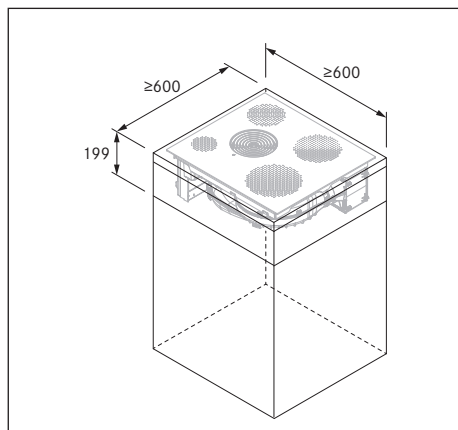

Fig. 10.4 Minimum unit dimensions for S Pure

## 10.5 Worktop cut-out

**i** The minimum measurement of 50 mm from the front edge of the worktop to the worktop cut-out is a recommendation from BORA.

- ▶ Create the worktop cut-out taking into account the specified cut-out dimensions.
- ▶ Make sure that the cut surfaces of the worktops are properly sealed.
- ▶ Comply with the instructions of the worktop manufacturer.

## 10.5.1 S Pure cut-out dimensions (PURSA, PURSU)

### S Pure flush installation (PURSA, PURSU)

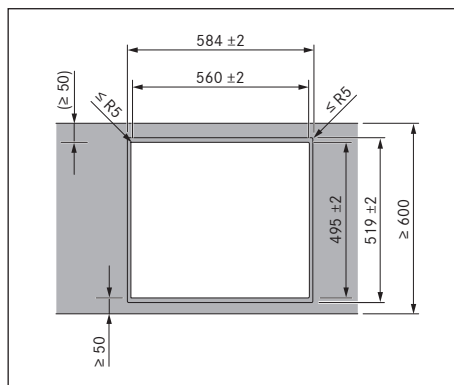

Fig. 10.5 Cut-out dimensions for flush installation

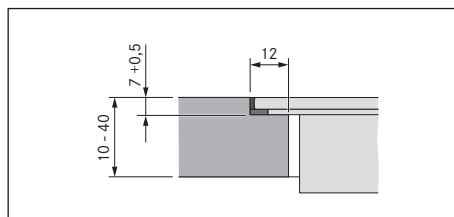

Fig. 10.6 Rebate dimensions for flush installation

### S Pure surface mounting (PURSA, PURSU)

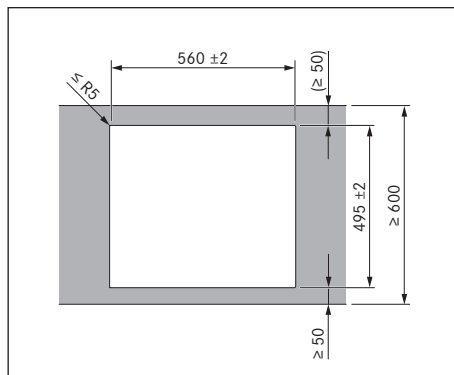

Fig. 10.7 Cut-out dimensions for surface mounting

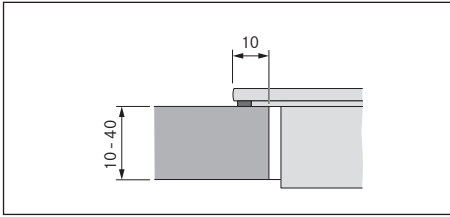

Fig. 10.8 Overlay dimensions for surface mounting

## 10.6 Installing the appliance in exhaust air mode (PURSA)

- i** National and regional laws and regulations must be observed with regard to the exhaust duct design.
- i** A sufficient air supply must be ensured
- i** The exhaust air must be directed to the outside by appropriate exhaust air ducts.
- i** The minimum cross-section of the air ducts must be  $176 \text{ cm}^2$ , which equates to a round pipe with a diameter of 150 mm or the BORA Ecotube duct system.
- i** As a general rule, with the built-in fan, a length of duct of up to 6 metres with six  $90^\circ$  bends, 8 metres with four  $90^\circ$  bends or 10 metres with two  $90^\circ$  bends can be installed.
- i** Not compatible with BORA Universal fans.
- i** You can find planning instructions for installation of the exhaust air ducts in the BORA planning guide.

### 10.6.1 Preparing kitchen units for the exhaust air model

- Cross bars on the kitchen unit in the area of the worktop cut-out may need to be removed.
- In the case of thin worktops, there must be a sufficiently rigid support plate on the unit.
- The back panel of the floor unit must be adapted for the exhaust air duct.

- A minimum clearance of 120 mm between the back panel of the unit and an adjacent kitchen unit or room wall must be observed for the air duct.
- No false floor is necessary below the cooktop. If cable protection (false floor) is planned, the following must be taken into account:
  - It must be fitted in such a way that it can be removed from below for maintenance work.
  - To ensure sufficient cooktop ventilation, a minimum distance of 15 mm to the bottom edge of the cooktop is to be observed.
- The drawers and/or shelves in the floor unit must be removable.
- For correct installation, the drawers of the floor unit must be shortened depending on the installation situation.

### 10.6.2 Installation dimensions

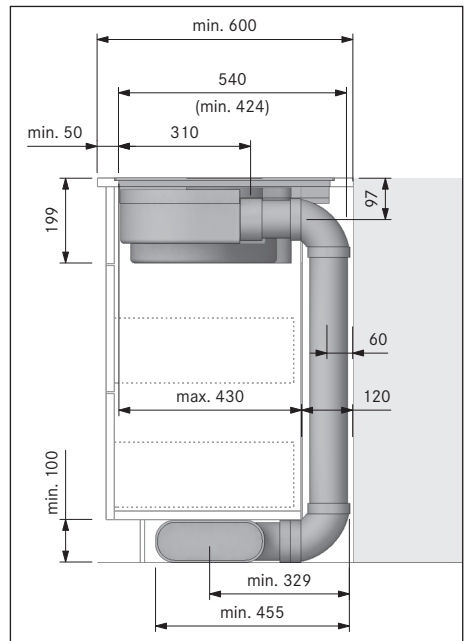

Fig. 10.9 Installation dimensions for exhaust air, worktop depth 600 mm

### Adjusting the back panel of the unit

- ▶ Before installation, check the suitability of the floor unit with regard to the necessary installation dimensions for the appliance and the planned duct system.
- ▶ If necessary, adjust the position of the back panel according to the required installation dimensions.

## 10.6.3 Preparing the cooktop

### Attaching the sealing tape

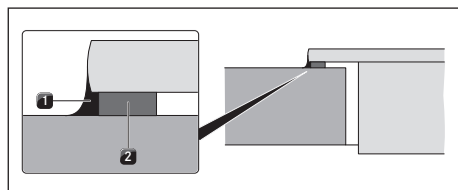

Fig. 10.10 Sealing tape in the case of surface mounting

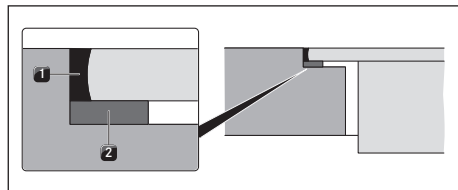

Fig. 10.11 Sealing tape in the case of flush installation

- [1] Black, heat-resistant silicone sealant
- [2] Sealing tape

- ▶ In the case of surface mounting, attach the enclosed sealing tape [2] around the outer edges of the underside of the cooktop. Do not leave any gaps.
- ▶ In the case of flush installation, attach the sealing tape [2] to the horizontal cutting edge in the worktop cut-out, even if you are sealing the cooktop with a silicone sealing compound [1] or similar.

## 10.6.4 Inserting the cooktop

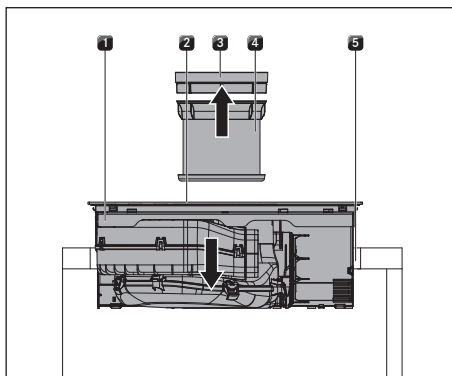

Fig. 10.12 Inserting the cooktop

- [1] Cooktop
- [2] Inlet opening
- [3] Air inlet nozzle
- [4] Stainless steel grease filter
- [5] Worktop cut-out

- ▶ Before inserting the cooktop, remove the air inlet nozzle [3] and the stainless steel grease filter [4].
- ▶ Use the inlet opening [2] as a handle during insertion.
- ▶ Keep the cooktop [1] straight as you lift it into the worktop cut-out [5].
- ▶ Insert the cooktop [1] into the centre of the worktop cut-out [5].
- ▶ Precisely align the cooktop.

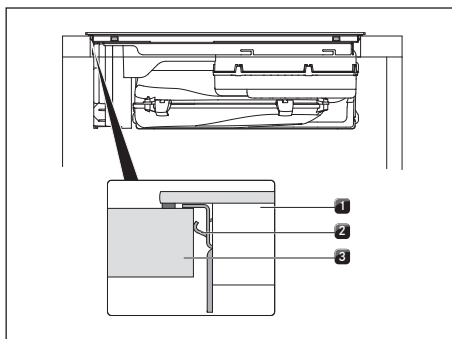

Fig. 10.13 Securing the cooktop in the middle

- [1] Cooktop
- [2] Holding clamp
- [3] Worktop

- ▶ When aligning the cooktop, ensure that the holding clamps hold the cooktop in the worktop.

#### Information regarding surface mounting:

- ▶ make sure that the cooktop sealing tape is flat against the worktop.

#### Information regarding flush installation:

- ▶ make sure that the cooktop sealing tape is well sealed all the way round.

#### Height adjustment plates for flush installation (optional)

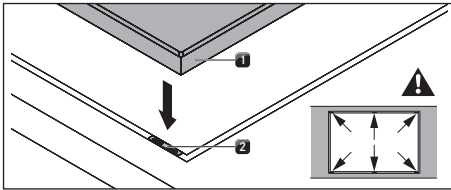

Fig. 10.14 Inserting height adjustment plates

- [1] Cooktop
- [2] Height adjustment plate

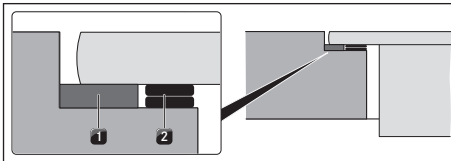

Fig. 10.15 Height adjustment plates

- [1] Sealing tape
- [2] Optional height adjustment plates
- The height adjustment plates are self-adhesive to prevent slipping during installation.
- ▶ If applicable, insert the height adjustment plates [2].
- ▶ Place the height adjustment plates next to the sealing tape [2].

### 10.6.5 Connecting the appliance to the duct system

- i** The duct system must be fitted to the appliance free of load and with the power supply switched off.
- i** For correct installation, the drawers of the floor unit must be shortened depending on the installation situation.
- i** When attaching the seals, ensure that an airtight seal is created with the connecting duct piece when the seals are compressed.

- ▶ Use only BORA Ecotube duct parts.
- ▶ Do not use flexible or fabric hoses.

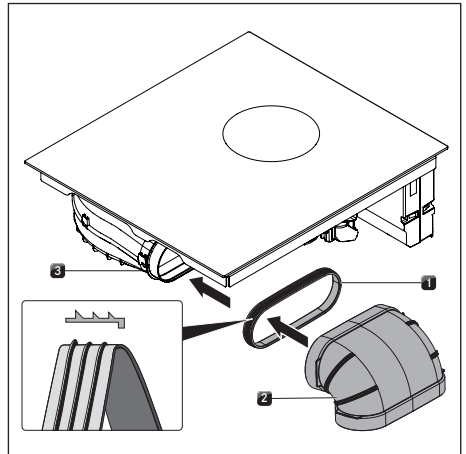

Fig. 10.16 Connecting the duct system

- [1] Seal
- [2] Duct part
- [3] Exhaust opening

- ▶ Pull the seal [1] onto the exhaust opening [3] on the appliance. To do this, the seal [1] will need to be stretched slightly.
- ▶ Push the duct part to be connected [2] with the coupling onto the exhaust opening [3] with the seal [1].
- ▶ Ensure that the seal [1] is not displaced.

## 10.7 Installing the appliance in recirculation mode (PURSU)

### 10.7.1 Recirculation of air from the kitchen unit

In the case of recirculation appliances, a return flow aperture of  $\geq 500 \text{ cm}^2$  must be provided in the kitchen unit to guide the clean recirculated air out of the unit and back into the room.

The return flow aperture can be created above a shortened plinth. A slatted plinth with at least the minimum opening cross-section can also be used.

**i** A return flow aperture  $\geq 500 \text{ cm}^2$  must be provided in the kitchen units.

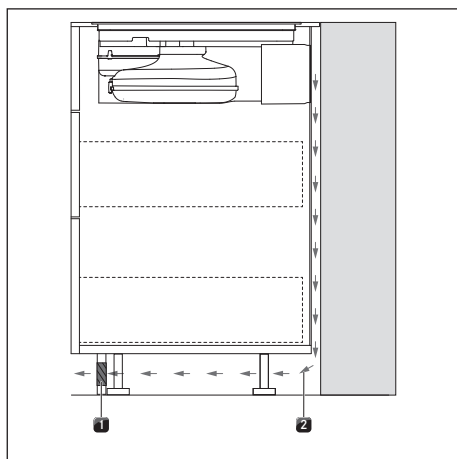

Fig. 10.17 Return flow aperture in the plinth area

- [1] Return flow aperture in the plinth (total cross-section of the aperture  $\geq 500 \text{ cm}^2$ )
- [2] Return flow of recirculated air

► Decrease the height of the plinth panel or create corresponding openings in the plinth.

### 10.7.2 Installation variants (A and B) for recirculation appliances

There are 2 installation variants for recirculation appliances PUXU and PURU: A and B

#### A: floor unit with continuous back panel

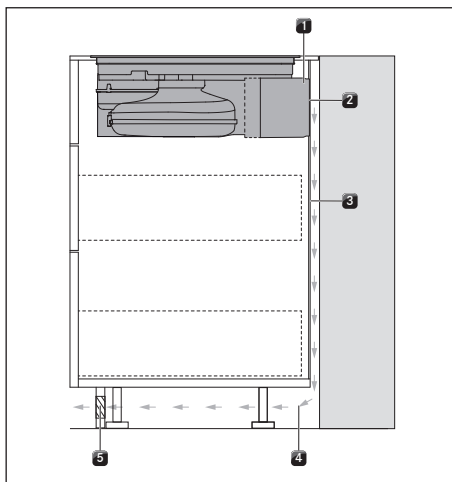

Fig. 10.18 Installation variant with continuous back panel

- [1] Air cleaning box
- [2] Connection with the back panel
- [3] Continuous back panel in the unit
- [4] Return flow of recirculated air
- [5] Return flow aperture

The recirculated air [4] is guided through the connection with the back wall [2] of the air cleaning box [1] directly behind the back panel of the unit [3]. The recirculated air goes back in to the room through the return flow aperture [5].

For installation purposes, this means that:

- No false floor is necessary below the cooktop.
- There must be a cut-out in the back panel.

**B: floor unit with false floor under the cooktop**

Fig. 10.19 Installation variant with false floor

- [1] Worktop
- [2] Air cleaning box
- [3] False floor
- [4] Back panel of unit
- [5] Return flow of recirculated air
- [6] Return flow aperture

The recirculated air [5] is blown into the free space between the worktop [1] and the false floor [3] (the air cleaning box [2] does not connect with the back panel). The recirculated air goes behind the rear panel of the unit [4] and through the return flow aperture [6] back into the room.

For installation purposes, this means that:

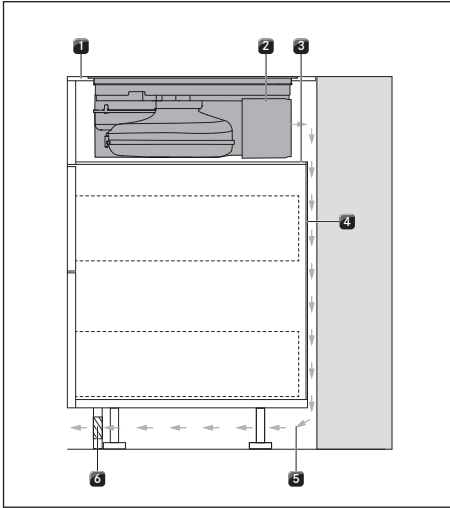
- a false floor is necessary below the cooktop.
- There does not need to be a cut-out in the back panel of the unit.

### 10.7.3 Preparing kitchen units for installation variant A (floor unit with continuous back panel)

- Cross bars on the kitchen unit in the area of the worktop cut-out may need to be removed.

- In the case of thin worktops, there must be a sufficiently rigid support plate on the unit.
- The floor unit must have a continuous back panel so that the recirculated air is not directed into the front furniture body compartment.
- There must be a cut-out in the back panel.
- A minimum clearance of 25 mm between the back panel of the unit and an adjacent kitchen unit or room wall must be observed for the return flow of the recirculation air.
- No false floor is necessary below the cooktop. If cable protection (false floor) is planned, the following must be taken into account:
  - it must be fitted in such a way that it can be removed for maintenance work.
  - To ensure sufficient cooktop ventilation, a minimum distance of 15 mm to the bottom edge of the cooktop is to be observed.
- The drawers and/or shelves in the floor unit must be removable.
- For correct installation, the drawers of the floor unit must be shortened depending on the installation situation.

### 10.7.4 Installation dimensions

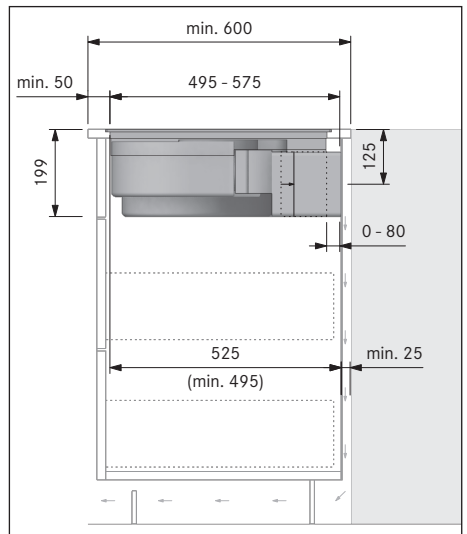

Fig. 10.20 Installation dimensions in the case of recirculated air, installation variant A

### Adjusting the back panel of the unit

- ▶ Adapt the back panel according to the required installation dimensions.
- ▶ If necessary, move the back panel.
- ▶ If necessary, extend the height of the back panel so that the unit is closed to the front.

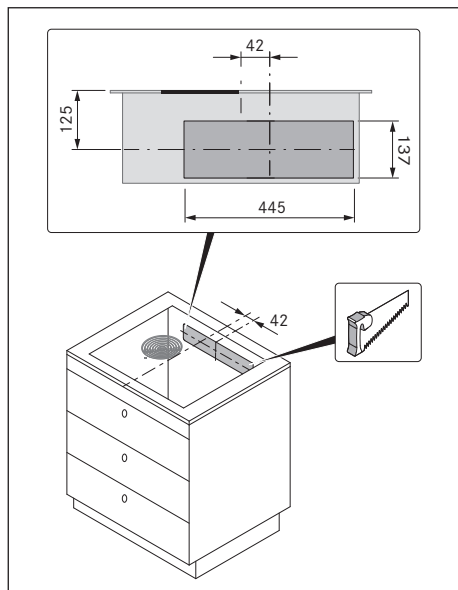

Fig. 10.21 Back panel cut-out

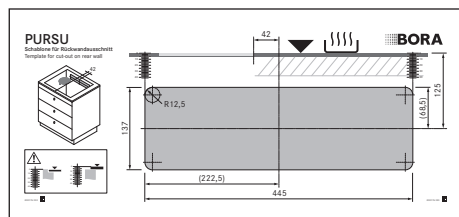

Fig. 10.22 Template for back panel cut-out

- ▶ Position the template on the back panel of the unit with the help of the markings and instructions.

- i** Flush installation and surface installation must be taken into account when positioning the template.  
125 mm from the top edge of the cooktop to the middle of the cut-out.

- ▶ Draw the back panel cut-out.
- ▶ Saw out back panel cut-out.

### 10.7.5 Preparing kitchen units for installation variant B (floor unit with false floor under the cooktop)

- Cross bars on the kitchen unit in the area of the worktop cut-out may need to be removed.
- In the case of thin worktops, there must be a sufficiently rigid support plate on the unit.
- A false floor must be provided for under the cooktop:
  - it must be fitted in such a way that it can be removed for maintenance work.
  - To ensure sufficient cooktop ventilation, a minimum distance of 15 mm to the bottom edge of the cooktop is to be observed.
- The back panel of the unit must be flush with the false floor so that the recirculating air is not directed into the front of the unit.
- A minimum clearance of 25 mm between the back panel of the unit and an adjacent kitchen unit or room wall must be observed for the return flow of the recirculation air.
- The drawers and/or shelves in the floor unit must be removable.
- For correct installation, the drawers of the floor unit must be shortened depending on the installation situation.

## 10.7.6 Installation dimensions

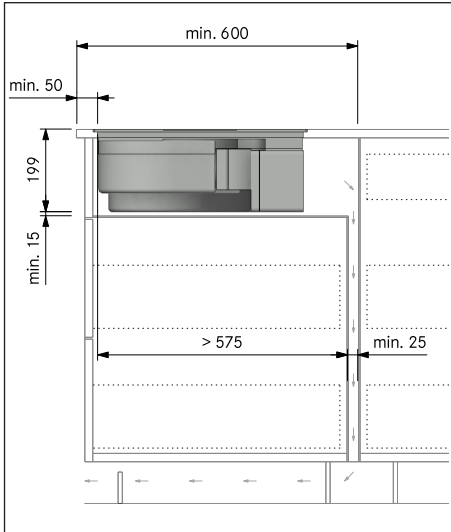

**Fig. 10.23** Installation dimensions for recirculation installation variant B, depth of worktop 600 mm

### Adjusting the back panel of the unit

- ▶ Adapt the back panel according to the required installation dimensions.
- ▶ If necessary, move the back panel.
- ▶ Adjust the height of the back panel to the false floor so that they are flush with one another.

## 10.7.7 Preparing the cooktop

### Attaching the sealing tape

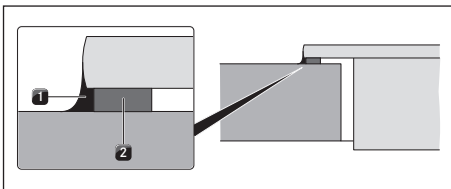

**Fig. 10.24** Sealing tape in the case of surface mounting

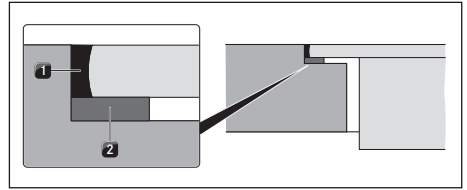
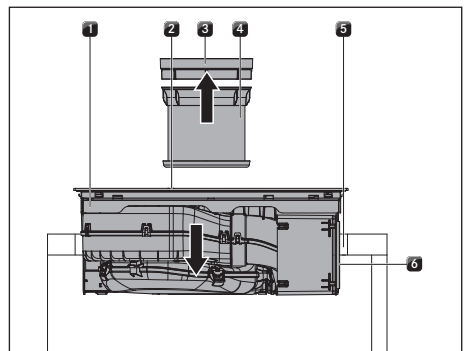

**Fig. 10.25** Sealing tape in the case of flush installation

- [1] Black, heat-resistant silicone sealant
- [2] Sealing tape

- ▶ In the case of surface mounting, attach the enclosed sealing tape [2] around the outer edges of the underside of the cooktop. Do not leave any gaps.
- ▶ In the case of flush installation, attach the sealing tape [2] to the horizontal cutting edge in the worktop cut-out, even if you are sealing the cooktop with a silicone sealing compound [1] or similar.

## 10.7.8 Inserting the cooktop



**Fig. 10.26** Positioning the cooktop in the centre

- [1] Cooktop
- [2] Inlet opening
- [3] Air inlet nozzle
- [4] Stainless steel grease filter
- [5] Worktop cut-out
- [6] Adhesive tape

- ▶ Before inserting the cooktop, remove the air inlet nozzle [3] and the stainless steel grease filter [4].
- ▶ Remove the protective film from the adhesive tape [6] on the front of the telescopic pull-out.
- ▶ Use the inlet opening [2] as a handle during insertion.
- ▶ Keep the cooktop [1] straight as you lift it into the worktop cut-out [5].
- ▶ Insert the cooktop [1] into the centre of the worktop cut-out [5].
- ▶ Precisely align the cooktop.

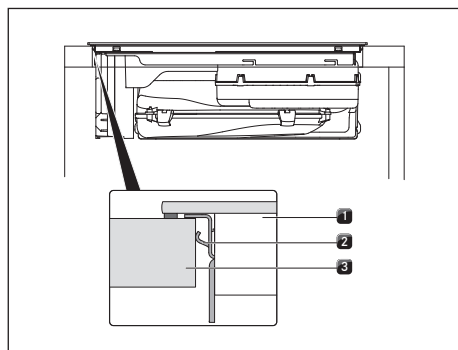

Fig. 10.27 Securing the cooktop

- [1] Cooktop
- [2] Holding clamp
- [3] Worktop

- ▶ When aligning the cooktop, ensure that the holding clamps hold the cooktop in the worktop.

#### Information regarding surface mounting:

- ▶ make sure that the cooktop sealing tape is flat against the worktop.

#### Information regarding flush installation:

- ▶ make sure that the cooktop sealing tape is well sealed all the way round.

#### Height adjustment plates for flush installation (optional)

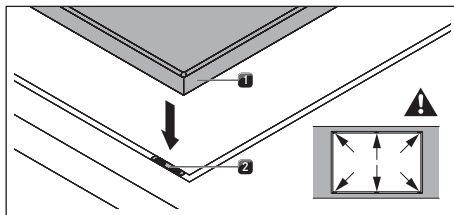

Fig. 10.28 Height adjustment plates

- [1] Cooktop
- [2] Height adjustment plate

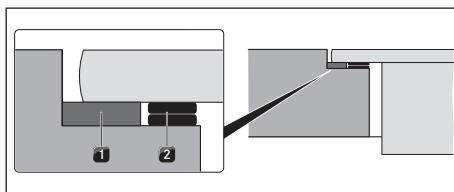

Fig. 10.29 Height adjustment plates

- [1] Sealing tape
- [2] Optional height adjustment plates

- The height adjustment plates are self-adhesive to prevent slipping during installation.
- ▶ If applicable, insert the height adjustment plates [2].
- ▶ Place the height adjustment plates next to the sealing tape [2].

#### 10.7.9 Making a connection with the back panel (only in installation variant A)

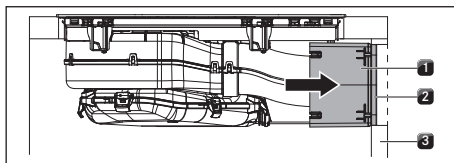

Fig. 10.30 Connection with the back panel

- [1] Telescopic pull-out
- [2] Adhesive tape
- [3] Back panel of unit

- ▶ Push the telescopic pull-out [1] until it is tight up against the back panel of the unit [3].
- With the telescopic pull-out the distance to the back panel of the unit can be flexibly bridged.
- ▶ Check that the telescopic pull-out [1] fits accurately, is flush with the cut-out on the back panel of the unit [3] and closes it off.
- ▶ Secure the telescopic pull-out [1] to the back panel of the unit [3] using the adhesive tape [2]

### 10.7.10 Inserting the activated charcoal filter

- i** Removing the filter – see „8.6 Replacing the activated charcoal filter“

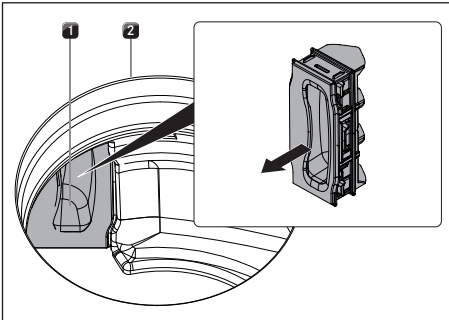

Fig. 10.31 Remove the filter replacement cover

- [1] Filter replacement cover  
[2] Inlet opening

- ▶ Inside the inlet opening [2] pull the filter replacement cover [1] out through the opening in the filter housing.

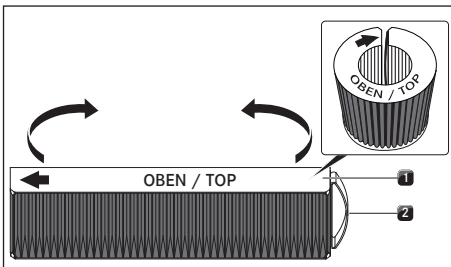

Fig. 10.32 Activated charcoal filter

- [1] Activated charcoal filter  
[2] Grip strap

- ▶ Remove the packaging from the activated charcoal filter [1].
- ▶ Position the activated charcoal filter correctly with the help of the printed symbols (arrow left, grip strap [2] right).
- ▶ Hold the activated charcoal filter at both ends.
- ▶ Bend the activated charcoal filter into a cylindrical shape so that both ends of the filter are opposite each other.

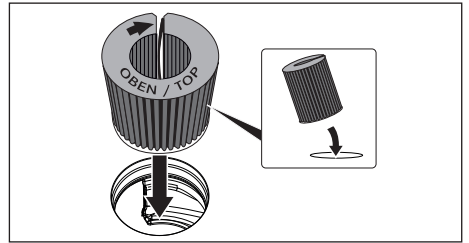

Fig. 10.33 Inserting the activated charcoal filter through the vent opening

- ▶ Tilt the activated charcoal filter towards you slightly and insert it through the inlet opening.
- ▶ Guide the left end of the filter into the opening in the filter housing.

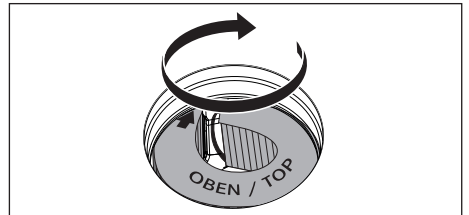

Fig. 10.34 Placing the activated charcoal filter in the end position

- ▶ Push the activated charcoal filter into the filter housing until it will go no further (to do this, you can place one finger between the slats and gradually push the filter into the housing).
- The end position of the activated charcoal filter is reached when the filter has been fully pushed inside the filter housing.

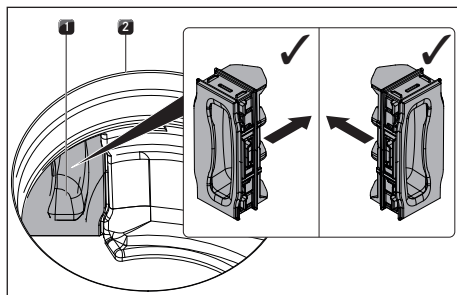

Fig. 10.35 Inserting the filter replacement cover

- [1] Filter replacement cover  
[2] Inlet opening

- ▶ Inside the inlet opening push the filter replacement cover until it comes to a stop in the filter housing opening.
- ▶ Check that the filter replacement cover is positioned correctly.

## 10.8 Connecting the power supply

- ▶ Observe all safety and warning information (see „2 Safety“).
- ▶ Observe all national and regional laws and regulations as well as the supplementary regulations of the local utility companies.

**i** The appliances may only be connected to the mains power supply by certified specialists. The specialist also assumes responsibility for the proper installation and commissioning.

**i** Connections via plug-in contacts (Schuko plugs) are not permitted.

**i** 1-phase connection The appliance complies with the requirements of IEC 61000-3-12.

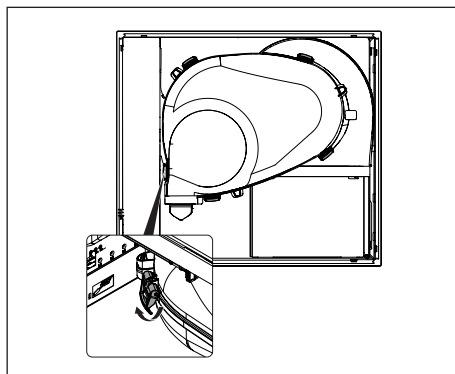

Fig. 10.36 Suction chamber locks

- ▶ Open the 5 suction chamber locks.

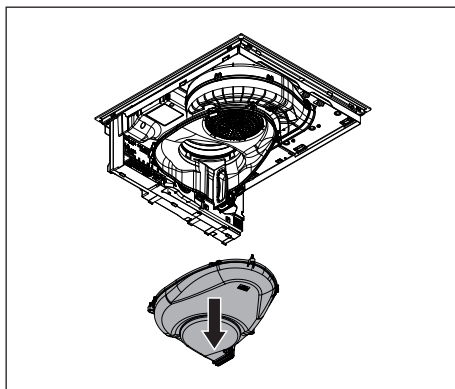
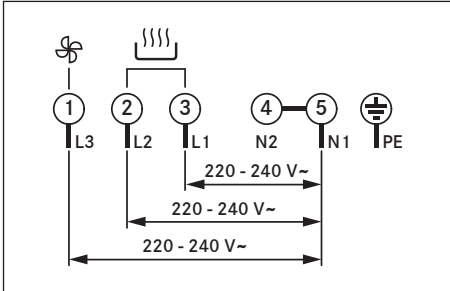

Fig. 10.37 Removing the bottom of the suction chamber

- ▶ Remove the bottom of the suction chamber.
- ▶ Switch off the main switch/automatic circuit breaker before connecting the cooktop.
- ▶ Secure the main switch/automatic circuit breaker against being switched back on without permission.
- ▶ Make sure the power to the appliance is disconnected.
- ▶ Connect the cooktop exclusively via a fixed connection to an H 05 VV-F power supply cable with corresponding minimum cross-section (see Table 10.2).

Connection	Fuse protection	Minimum cross-section
Three-phase connection	3 x 16 A	2.5 mm <sup>2</sup>
Two-phase connection	2 x 16 A	2.5 mm <sup>2</sup>
One-phase connection	1 x 32 A	4 mm <sup>2</sup>

**Tab. 10.2** Fuse protection and minimum cross-section



**Fig. 10.38** Connection diagram - three-phase connection

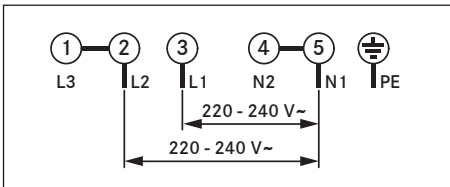

**Fig. 10.39** Connection diagram - two-phase connection

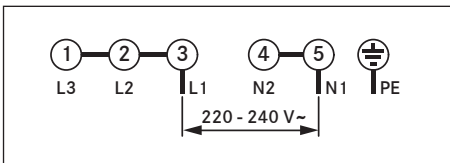

**Fig. 10.40** Connection diagram - one-phase connection

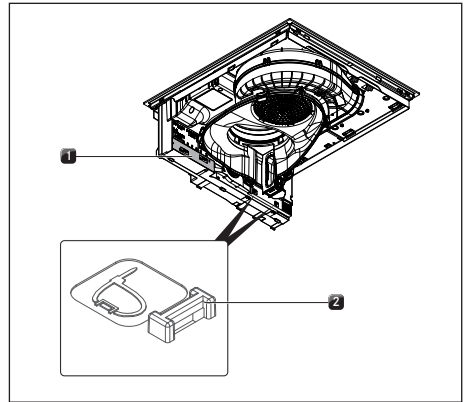

**Fig. 10.41** Electrical connections of the cooktop

- [1] Power supply cover  
[2] Mounting eyes

- ▶ Connect the power supply cable to the power supply of the appliance in accordance with the relevant connection diagram.
- ▶ For a one-phase or two-phase connection, connect the relevant contacts using the bridge provided (in scope of delivery).
- ▶ Secure the connection cable with the strain relief clamp (in scope of delivery).
- ▶ Close the power supply housing with the power supply cover [1] (in scope of delivery).
- ▶ Lay the connection cable along the mounting eyes [2] with the help of the cable ties (in scope of delivery).
- ▶ Ensure that the cable is not trapped or damaged and is not able to come into contact with any hot areas on the cooktop.
- ▶ Attach the bottom of the suction chamber with the 5 suction chamber locks.
- ▶ Check that installation has been carried out correctly.

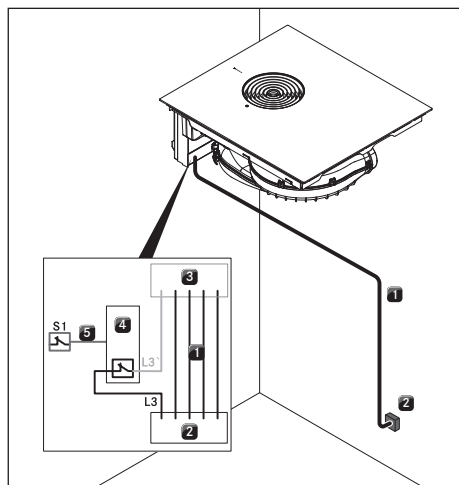

Fig. 10.42 Connection diagram with external switch contact

- [1] Cooktop and cooktop extractor power supply cable
- [2] Power supply
- [3] Cooktop and cooktop extractor power supply
- [4] Switch relay
- [5] Switch connection S1 and switch relay
- [S1] External switch contact

## 10.9 Initial operation

- i** During initial operation some basic settings (basic configuration) must be applied using the dealer and service menu.

### 10.9.1 Dealer and service menu

- i** The dealer and service menu can be called up up to 2 minutes after the appliance has been connected to the power supply.
- i** The system adopts and saves the settings made when you exit the corresponding menu item.
- i** Below you will find explanations on how to use the menu and a description of the most important menu items.

### Dealer and service menu overview

Menu item/Description/Selection area	Factory setting
B Extraction system (exhaust air/ recirculation system)	Recirculation
C Power management	☰
D Demo mode	Off

Tab. 10.3 Menu overview

### Calling up the dealer and service menu

- ▶ Connect the appliance to the power supply.

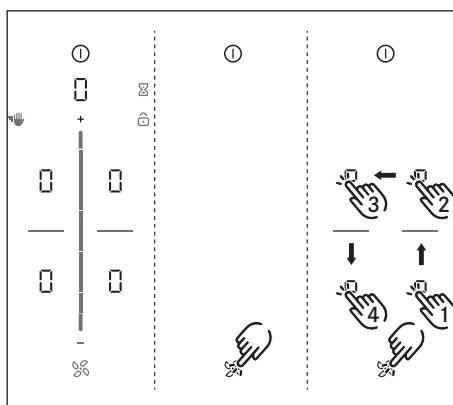





Fig. 10.43 Calling up the dealer and service menu

- The standard display appears and the fan symbol pulses for 2 minutes.
- ▶ Long press on the fan button .
- 4 input points  are shown.
- ▶ Keep the fan button  pressed and at the same time press the input points  in the specified order.
- Menu item B is displayed.

## Menu item B: Extraction system configuration

The extraction system must be configured.  
There are two operating modes to choose from:

- Operating mode 1: recirculation system (factory setting)
- Operating mode 2: exhaust air system

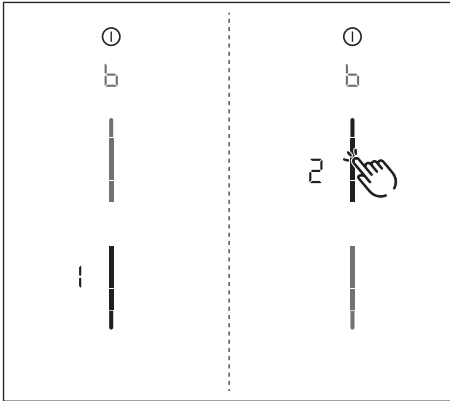

**Fig. 10.44** Display Menu item B: Configuring the extraction system

- ▶ Select the corresponding operating mode (tap the corresponding segment on the slider).
- ▶ Confirm and save the setting by moving to the next menu item (tap the multi-function display/indicator b).

## Menu item C: Power management

The total appliance power can be reduced if the required electrical power cannot be provided at the installation site.

- i** The cooking zone power restrictions automatically implemented by the appliance are determined according to the total power set.

There are three operating modes to choose from:

Power management	Connection	Maximum power consumption	Fuse protection
C3	three-phase	7250 W	3 x 16 A
C3	two-phase	7250 W	2 x 16 A
C3	single-phase	7250 W	1 x 32 A
C2	single-phase	4400 W	1 x 20 A
C1	single-phase	3600 W	1 x 16 A

**Tab. 10.4** Power management

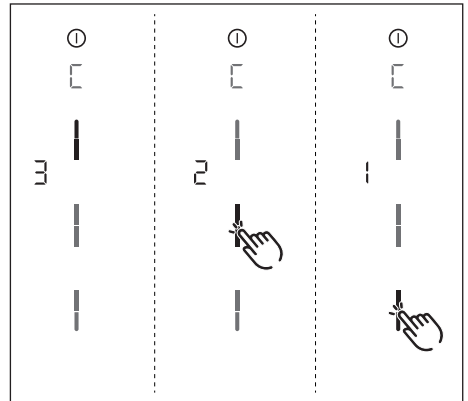

**Fig. 10.45** Display menu item C: Power management

- ▶ Select the corresponding operating mode (tap the corresponding segment on the slider).
- ▶ Confirm and save the setting by moving to the next menu item (tap the multi-function display/indicator C).

## Menu item D: Demo mode

The appliance can be set to demo mode, which includes all operating functions, but the heating function of the cooktops is deactivated.

- i** Pan size recognition is deactivated in demo mode.

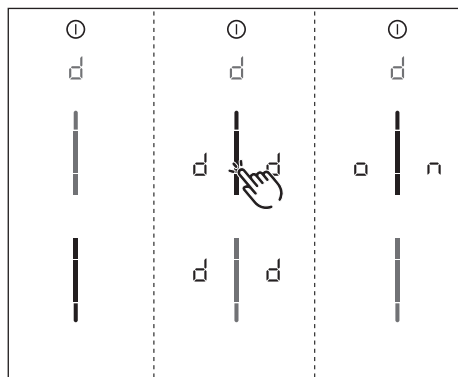

Fig. 10.46 Display Menu item D: Demo mode

- ▶ Tap the top slider segment.
- The demo mode symbol **d** is displayed on all cooking zones for one second.
- **d** is displayed.
- ▶ Confirm and save the setting by moving to the next menu item (tap the multi-function display/indicator **d**).

### Closing the dealer and service menu

When you have been through all of the basic configuration menu items:

- ▶ long press on the multi-function display.
- The standard display appears.

## 10.9.2 Function test

- ▶ Carry out a thorough function test on all appliances.
- ▶ In the event of error messages, see the “Troubleshooting” chapter (see „9 Troubleshooting“).

## 10.10 Sealing the appliance

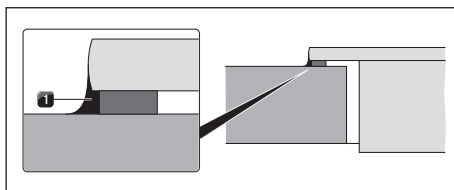

Fig. 10.47 Silicone sealant for surface mounting

- [1] Black, heat-resistant silicone sealant

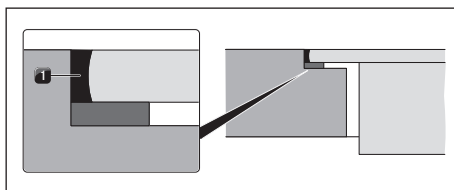

Fig. 10.48 Silicone sealant for flush installation

- [1] Black, heat-resistant silicone sealant

- ▶ Once all of the installation work is complete, seal the appliance with black, heat-resistant silicone sealant [1].
- ▶ Make sure that no silicone sealant gets under the cooktop.

## 10.11 Handover to user

Once installation is complete:

- ▶ Explain the main functions to the user.
- ▶ Explain all safety-related aspects of operation and handling to the user.
- ▶ Provide the user with the accessories and operating and installation instructions, which are to be kept in a safe place.

# 11 Decommissioning, disassembly and disposal

- ▶ Observe all safety and warning information (see „2 Safety“).
- ▶ Follow the enclosed manufacturer’s information.

## 11.1 Decommissioning

Decommissioning is understood as final shutdown and disassembly. Following decommissioning, the device can either be installed into other units, sold on privately or disposed of.

**i** Electricity and gas connections may only be disconnected by qualified specialists.

- ▶ To decommission, switch the device off (see „6 Functions and operation“).
- ▶ Disconnect the device from the power supply.

## 11.2 Disassembly

For removal, the device must be accessible for disassembly and disconnected from the power supply.

- ▶ Remove the silicone joints.
- ▶ Remove the device from the worktop by lifting it upwards.
- ▶ Remove any other accessories.
- ▶ Dispose of the old device and any contaminated accessories as described under “Environmentally-friendly disposal”.

## 11.3 Environmentally-friendly disposal

### Disposal of transport packaging

**i** The packaging protects the device from damage in transport. The packaging materials have been selected from environmental and disposal perspectives and are therefore recyclable.

Returning the packaging to the materials cycle saves resources and reduces waste volumes. Your specialist supplier will take the packaging back.

- ▶ Give the packaging to your specialist supplier or
- ▶ Dispose of the packaging properly in line with local regulations.

### Disposal of old appliance



Electrical devices marked with this label may not be disposed of in domestic waste at the end of their service life. They must be disposed of at a collection point for the recycling of old electrical or electronic devices. You can find information from your city or district council.

Many electrical and electronic devices still contain valuable materials. But they also contain damaging materials which were necessary for them to function properly and safely. These can damage human health or the environment if disposed of improperly or incorrectly handled.

- ▶ Never put your old appliance in domestic waste.
- ▶ Take the old appliance to a regional collection point for return and recycling electrical and electronic components and other materials.

## 12 Warranty, technical service, spare parts, accessories

- Observe all safety and warning information (see “2 Safety”).

### 12.1 BORA manufacturer's warranty

BORA provides its end customers with a 2-year manufacturer's warranty for its products. The end customer is entitled to this warranty in addition to the statutory claims for defects against the sellers of our products.

The manufacturer's warranty applies to all BORA products purchased by authorised BORA dealers or salespersons trained by BORA within the European Union, with the exception of products labelled by BORA as Universal products or accessories.

The manufacturer's warranty starts as soon as the BORA product is handed over to the end customer by an authorised BORA dealer and is valid for 2 years.

By registering on [www.bora.com/registration](http://www.bora.com/registration) the end customer has the possibility of extending the manufacturer's warranty.

The manufacturer's warranty requires expert installation (in accordance with the valid BORA ventilation handbook and operating instructions at the time of installation) of the BORA products by an authorised BORA dealer. During use, the end customer is to adhere to the specifications and instructions in the operating manual.

In order to file a warranty claim, the end customer is to notify their dealer or BORA of the fault and must present the receipt. Alternatively, the end customer can provide proof of purchase by registering on [www.bora.com](http://www.bora.com).

BORA guarantees that all BORA products are free from material and production defects. The defect must exist prior to delivery of the product to the end customer. In the event that a warranty claim is filed, the warranty shall not commence anew.

BORA will correct defects in BORA products at its own discretion by repairing or replacing the product.

All costs for the correction of defects under the manufacturer's warranty shall be assumed by BORA. Expressly not covered by the BORA manufacturer's warranty are:

- BORA products that were not sold by authorised BORA dealers or salespersons trained by BORA
- Damage caused by non-adherence to the operating instructions (including product care and cleaning). This represents improper use.
- Damage caused by normal use, e.g. traces of usage on the cooktop
- Damage caused by external influences (such as transport damage, ingress of condensation, damage caused by the elements such as a lightning strike)
- Damage caused by repairs or attempts to repair not made by BORA or persons authorised by BORA
- Damage to the glass ceramic
- Voltage fluctuations
- Secondary damage or claims for damages beyond the defect
- Damage to plastic parts

Legal claims, particularly statutory claims for defects or product liability, are not limited by the warranty.

If a defect is not covered by the manufacturer's warranty, the end customer can employ the services of the BORA technical service, however, they must cover the costs themselves.

The laws of the Federal Republic of Germany apply to these warranty conditions.

You can contact us by:

- Telephone: +49 800 7890 0987  
Monday to Thursday from 08:00–18:00 and  
Friday from 08:00–17:00
- Email: [info@bora.com](mailto:info@bora.com)

### 12.1.1 Warranty extension

You can extend the warranty by registering on [www.bora.com/registration](http://www.bora.com/registration).

## 12.2 Service

### BORA Service:

see reverse side of the operating and assembly instructions

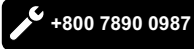

- ▶ In the case of faults you cannot fix yourself, contact your BORA specialist supplier or the BORA Service Team.

The BORA Service Team will require the type designation and serial number of your appliance (FD number).

You can find both details on the nameplate on the warranty form as well as on the bottom of the appliance.

## 12.3 Spare parts

- ▶ Only use original spare parts for repairs.
- ▶ Repairs may only be carried out by the BORA Service Team.

- i** Spare parts can be obtained from your BORA dealer, the BORA online service website at [www.bora.com/service](http://www.bora.com/service) or by calling the service number provided.

## 12.4 Accessories

- Stainless steel grease filter PUEF
- Air inlet nozzle black PUED
- Air inlet nozzle greige PUEDG
- Air inlet nozzle red PUEDR
- Air inlet nozzle jade green PUEDJ
- Air inlet nozzle orange PUEDO
- Air inlet nozzle blue PUEDB
- Air inlet nozzle light grey PUEDL
- Air inlet nozzle sun yellow PUEDS
- Trim USL515
- Trim All Black USL515AB
- Glass ceramic scraper UGS

### Special accessories PURSA:

- Window contact switch UFKS
- Air purification box PULB  
(for conversion from exhaust air to recirculation)

### Special accessory PURSU:

- Activated charcoal filter PUAKF





Operating and installation instructions:

Original

Translation

**Manufacturer: BORA Vertriebs GmbH & Co KG**

The distribution and duplication of this document, as well as the use and disclosure of its contents are prohibited unless expressly authorised.

These operating and installation instructions have been drawn up with the greatest of care. But it cannot be ruled out that subsequent technical modifications have not yet been incorporated or the relevant content has not yet been adapted. Please accept our apologies in this eventuality. An updated version can be requested from the BORA Service Team. Subject to printing errors and mistakes.

© BORA Vertriebs GmbH & Co KG

All rights reserved.

---

<b>D</b>	<b>A</b>	<b>INT</b>	<b>AU</b> <b>NZ</b>
<b>BORA Lüftungstechnik GmbH</b> Rosenheimer Str. 33 83064 Raubling Germany T +49 (0) 8035 / 9840-0 F +49 (0) 8035 / 9840-300 info@bora.com www.bora.com	<b>BORA Vertriebs GmbH &amp; Co KG</b> Innstraße 1 6342 Niederndorf Austria T +43 (0) 5373 / 62250-0 F +43 (0) 5373 / 62250-90 mail@bora.com www.bora.com	<b>BORA Holding GmbH</b> Innstraße 1 6342 Niederndorf Austria T +43 (0) 5373 / 62250-0 F +43 (0) 5373 / 62250-90 mail@bora.com www.bora.com	<b>BORA APAC Pty Ltd</b> 100 Victoria Road Drummoyne NSW 2047 Australia T +61 2 9719 2350 F +61 2 8076 3514 info@boraapac.com.au www.bora-australia.com.au

---

