

PUREDESIGN

OWNER'S MANUAL

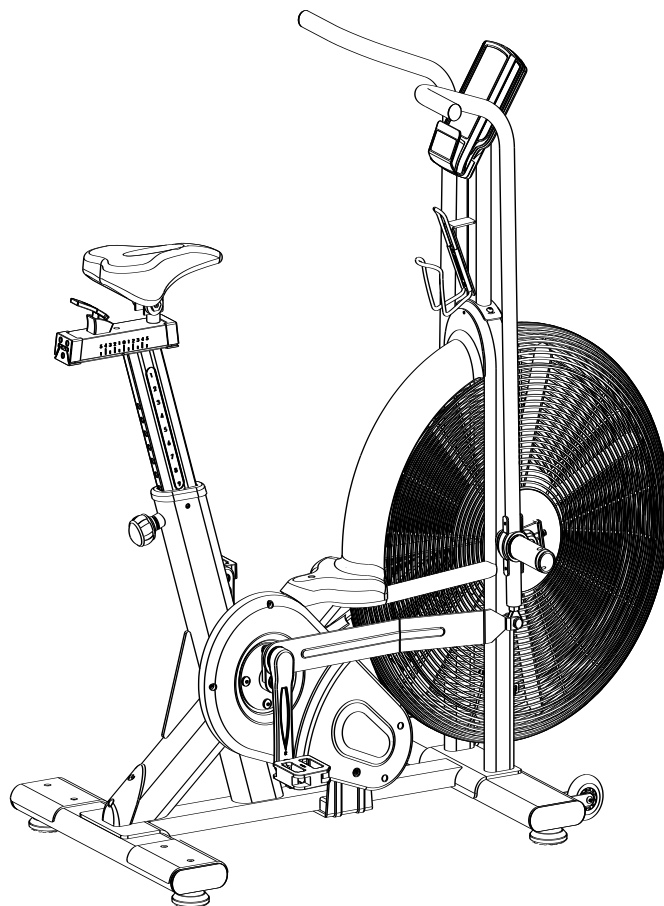

Product May Vary Slightly From Pictured.

CONTACT INFO

Address: 72 South Street, Rydalmere,
NSW 2112

Phone: 02 9898 1405

ITEM NO.: AB8

Contents

Safety Information	03
Assembly Instructions	04
Console Instruction	08
Exploded Diagrams	16
Parts List	17



Safety Information

Note the following precaution before assembling or operating the machine.

- Keep children and pets away from the Spinning Bike at all times. DO NOT leave unattended children in the same room with the machine.
- Handicapped or disabled persons should not use the Air Bike without the presence of a qualified health professional or physician.
- If the user experiences dizziness, nausea, chest pain, or any other abnormal symptoms, STOP the workout at once. CONSULT A PHYSICIAN IMMEDIATELY.
- Before beginning training, remove all within a radius of 2 meters from the machine. DO NOT place any sharp objects around the Spinning Bike.
- Position the Spinning Bike on a clear, level surface away from water and moisture. Place mat under the unit to help keep the machine stable and to protect the floor.
- Use the Spinning Bike only for its intended use as described in this manual. DO NOT use any other accessories not recommended by the manufacturer.
- Assemble the machine exactly as the descriptions in the instruction manual.
- Check all bolts and other connections before using the machine for the first time and ensure that the trainer is in the safe condition.
- Hold a routine inspection of the equipment. Pay special attention to components which are the most susceptible to wear off, i.e. connecting points and wheels. The defective components should be replaced immediately. The safety level of this equipment can only be maintained by doing so. Please don't use the Spinning Bike until it is repaired well.
- NEVER operate the Spinning Bike if it is not functioning properly.
- This machine can be used for only one person's training at a time.
- Do not use abrasive cleaning articles to clean the machine. Remove drops of sweat from the machine immediately after finishing training.
- Always wear appropriate workout clothing when exercising. Running or aerobic shoes are also required.
- Before exercising, always do stretching first.
- The power of the machine increases with increasing the speed, and the reverse. The machine is equipped with adjustable knob, which can adjust the resistance.

Assembly Instruction

1.PREPARATION:

- A. Before assembling make sure that you will have enough space around the item.
- B. Use the present tooling for assembling.
- C. Before assembling please check whether all needed parts are available (at the above of this instruction sheet you will find an explosion drawing with all single parts (marked with numbers) which this item consists of.

2.ASSEMBLY INSTRUCTION:

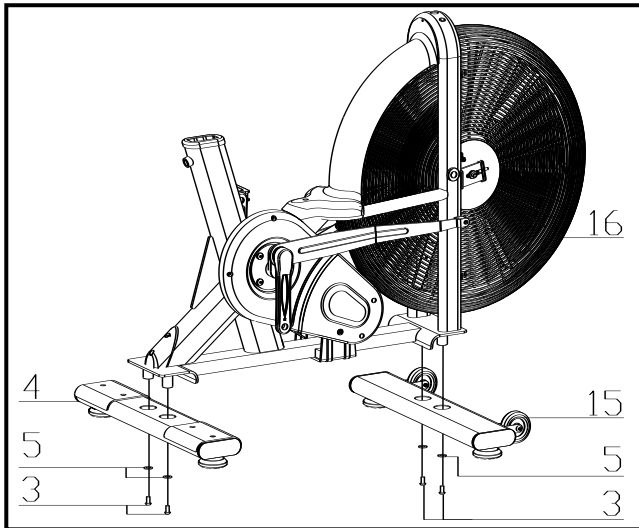

FIG.1

FIG.1:

Attach the Front Stabilizer (pt.15) to the Main Frame (pt.16) using two sets of Ø10 Flat Washers (pt.5) and bolt 1 (3).

Attach the Rear Stabilizer (pt.4) to the Main Frame (pt.16) using two sets of Ø10 Flat Washers (pt.5) and bolt 1 (3)

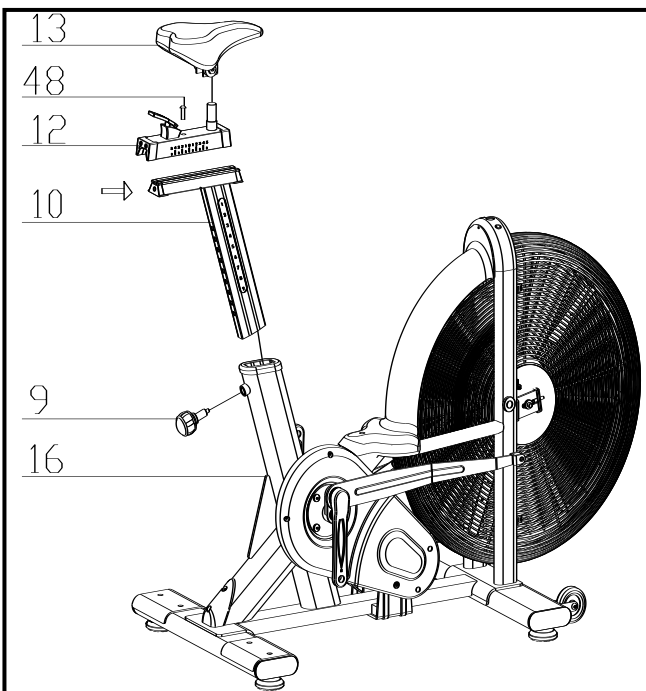

FIG.2

FIG.2:

Slide the Vertical Seat Post (pt.10) into the seat post housing on the main frame (pt.16). And put the knob up, then release the round nut(pt.48) , Then slide the Seat Post (pt.12) into the Vertical Seat Post (pt.10),Then fixing the bolt8 (pt.48), You will have to slacken the knurled section of the Adjustment Knob (pt.9) and pull the knob back and then select the desired height. Release the knob and retighten the knurled portion.

Now fix the Seat (pt.13) to the Seat Post (pt.12) as shown, and tighten the bolts around the screws under the seat.

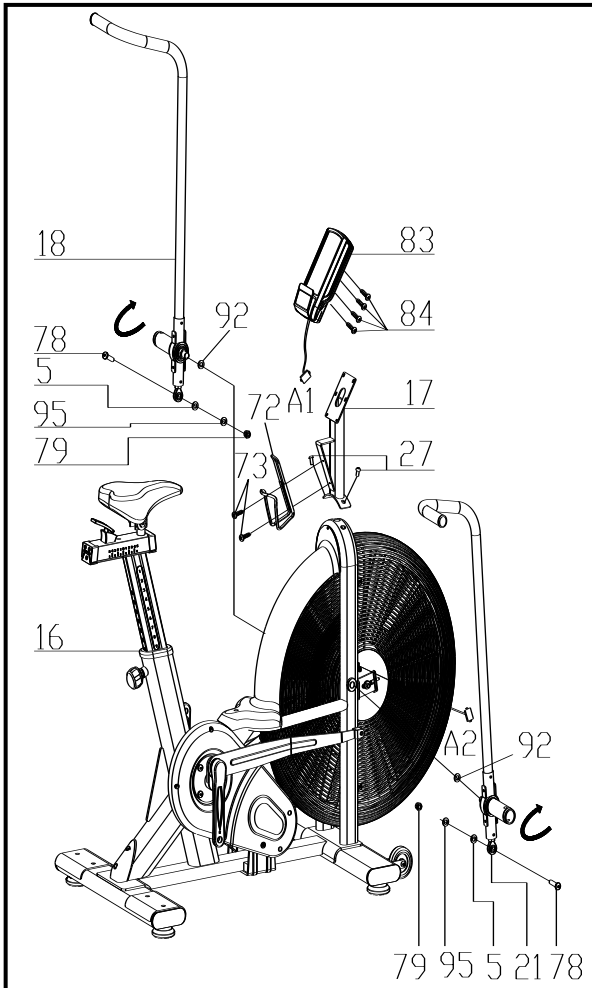

FIG.3:

The left hand assembly (18), the right wrench assembly (21) and the outer tooth type gasket (92) are fixed to the main frame assembly (16) in accordance with the graphic method, the inner six angle flat head screws (78), flat washer (5), Spring washer (95), the lock nut (79) drive assembly connected then, locking; electronic connection assembly (17) with six angle flat head screws (27) fixed to the main frame assembly (16), the cross slot screw (73) will Aluminum Alloy kettle (72) fixed to the main frame assembly (16) on,
ATTENTION: YOU SHOULD FIX THE HANDLEBAR TIGHTLY

The electronic meter assembly (83) with cross slot screw (84) fixed to the electronic connection assembly (17), connect the plug (A1&A2),

FIG.3

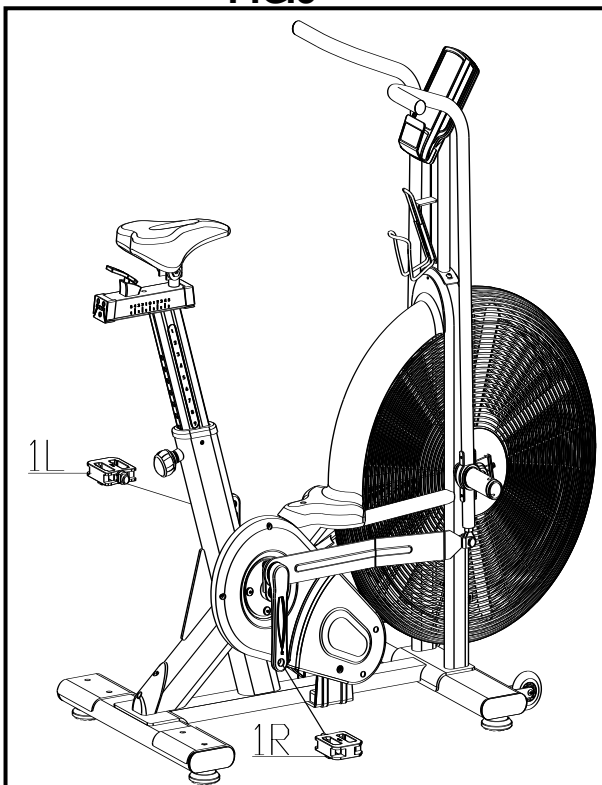

FIG.4:

The Pedals (pt.1 L & pt.1 R) are marked "L" and "R" - Left and Right. Connect them to their appropriate crank arms. The right crank arm is on the right- hand side of the cycle as you sit on it.
 Note that the Right pedal should be threaded on clockwise and the Left pedal anticlockwise.

FIG.4



- To adjust the seat height, slacken the spring knob on the vertical post stem on the main frame and pull back the knob. Position the vertical seat post for the desired height so that holes are aligned, then release the knob and retighten it.
- To move the seat forward in the direction of the handlebar or backwards away from it, loosen the adjusting knob and washer and pull the knob back. Slide horizontal seat post into desired position. Align holes and then retighten the adjusting knob.
- To adjust the handlebar height, slacken the spring knob and secondary knob and pull both knobs back. Slide the handlebar post along the housing on the main frame to the desired height and, with the holes aligned correctly, tighten the spring adjusting knob and then the secondary knob.

1.The Warm Up Phase

This stage helps get the blood flowing around the body and the muscles working properly. It will also reduce the risk of cramp and muscle injury. It is advisable to do a few stretching exercises as shown below. Each stretch should be held for approximately 30 seconds, do not force or jerk your muscles into a stretch - if it hurts, **STOP**.

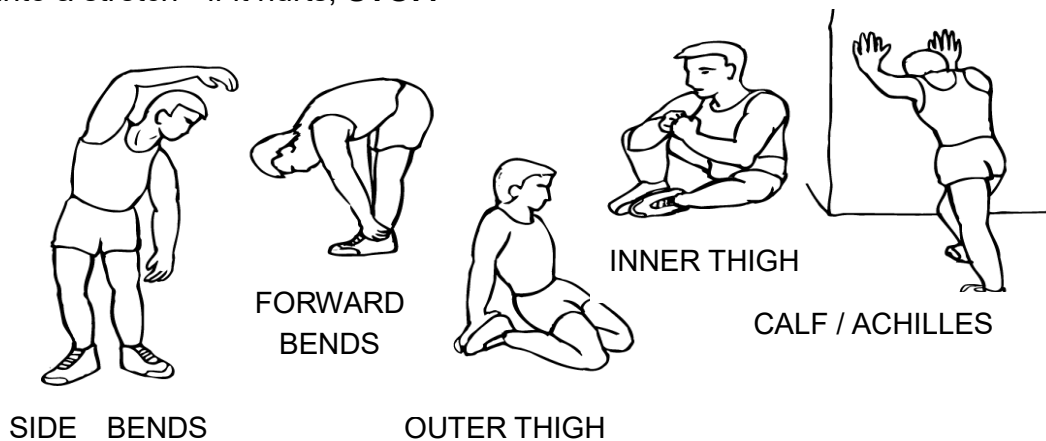

2.The Exercise Phase

This is the stage where you put the effort in. After regular use , the muscles in your legs will become Stronger. Work to your but it is very important to maintain a steady tempo throughout. The rate of work should be sufficient to raise your heart beat into the target zone shown on the graph below.

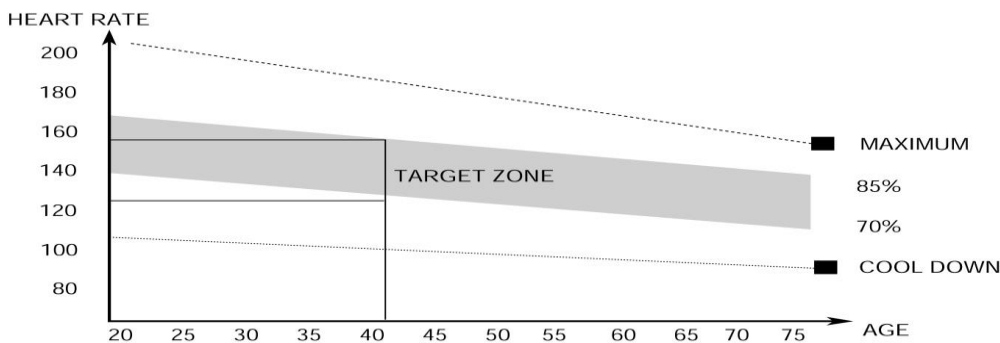

This stage should last for a minimum of 12 minutes for most people

This stage is to let your Cardio-vascular System and muscles wind down. This is a repeat of the warm up exercise e.g. reduce your tempo, continue for approximately 5 minutes. The stretching exercises should now be repeated, again remembering not to force or jerk your muscles into the stretch.

As you get fitter you may need to train longer and harder. It is advisable to train at least three times a week, and if possible space your workouts evenly throughout the week.

MUSCLE TONING

To tone muscle while on your **Air BIKE** you will need to have the resistance set quite high. This will put more strain on our leg muscles and may mean you cannot train for as long as you would like. If you are also trying to improve your fitness you need to alter your training program. You should train as normal during the warm up and cool down phases, but towards the end of the exercise phase you should increase resistance, making your legs work harder than normal. You may have to reduce your speed to keep your heart rate in the target zone.

WEIGHT LOSS

The important factor here is the amount of effort you put in. The harder and longer you work the more calories you will burn. Effectively this is the same as if you were training to improve your fitness, the difference is the goal.

USE

The tension control knob allows you to alter the resistance of the pedals. A high resistance makes it more difficult to pedal, a low resistance makes it easier. For the best results set the tension while the bike is in use.

Console Introduction

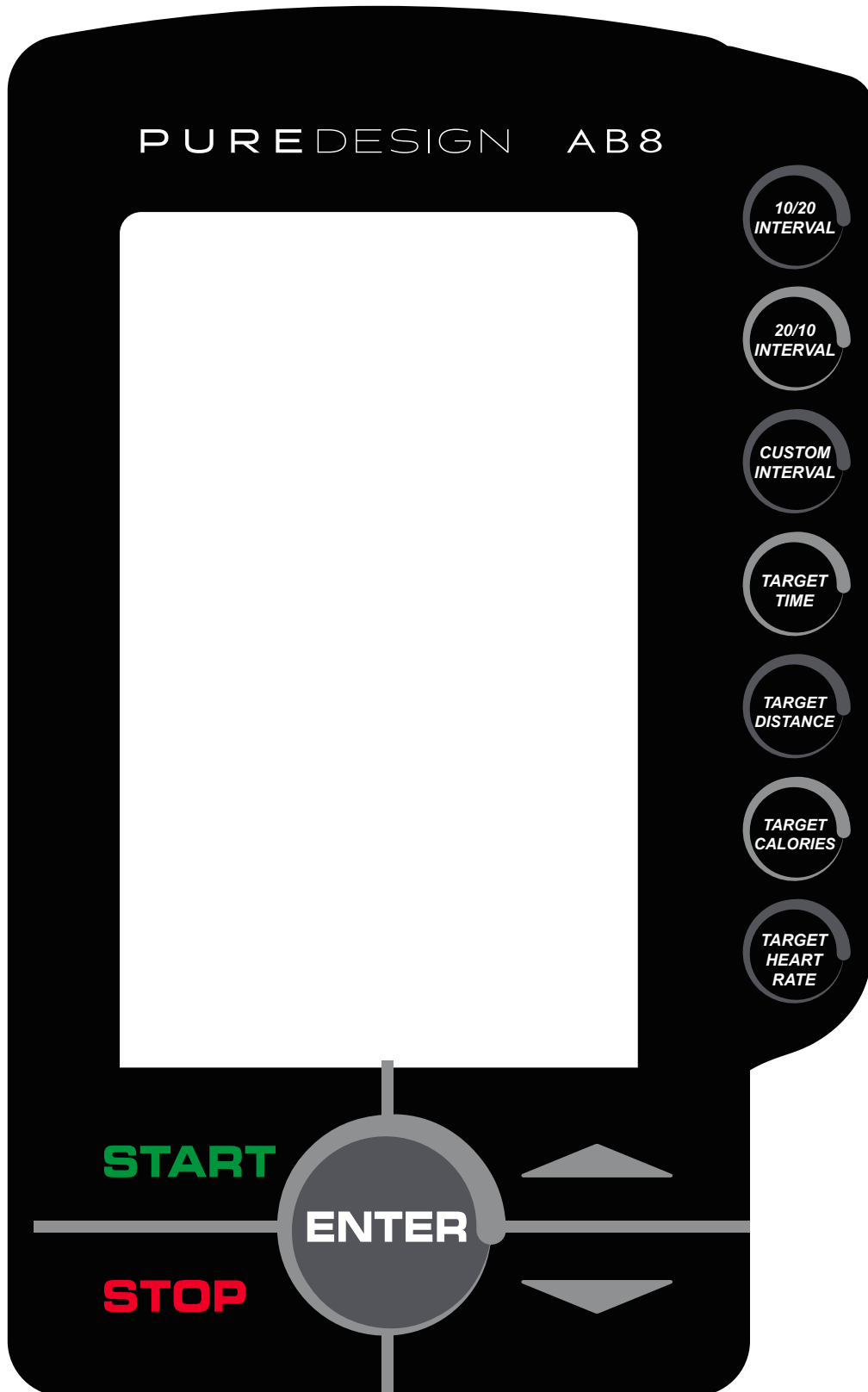

DISPLAY FUNCTIONS

TIME	DESCRIPTION
RPM	Display the rotation per minute with range from 0~ 199.
SPEED	Display current training speed. Maximum speed is 99.9 KM/H or ML/H.
TIME	Count up - No preset target. Time will count up from 00:00 to maximum 1:59:59 with each increment is 1 minute. Count down - The console will countdown from preset time to 00:00:00 and each preset increment or decrement will be 1 minute between 00:01:00 to 1:59:00.
DISTANCE	Accumulates total distance from 0.0 up to 999.9 KM or ML or count down from preset value. User may preset target distance value with UP/DOWN key. Each increment is 1.0KM or ML.
CALORIES	Accumulates calories consumption or count down during training from 0 to maximum 999 calories. User may preset target Calories with UP/DOWN key.
WATT	Display the power consumption during training. Display Range: 0~1999.
PULSE	User may set up target pulse value from 0~30 to 230 and the console buzzer will beep when the actual heart rate is over the target value during workout.

BUTTON FUNCTION

TIME	DESCRIPTION
START	To start workout quickly or resume workout in Stop mode.
STOP	To stop/pause workout. To clear up all settings. Hold on this key for 2 seconds to reboot the console.
DOWN	To adjust Distance, Calories, Heart-rate, Time, Age value down.
UP	To adjust Distance, Calories, Heart-rate, Time, Age value up.
Target Distance	Fast access to Target Distance training mode.
Target Calories	Fast access to Target Calories training mode.
Target Heart-rate	Fast access to Target Heart Rate training mode.
Target Time	Fast access to Target Time training mode.
Interval	There are 3 programs: INTERVAL 10/20, INTERVAL 20/10, Custom.
ENTER	To confirm settings or enter program.

OPERATION INSTRUCTION

1. When POWER ON, LCD will full display 2s (Figure 1) with long beep sound, then display wheel diameter 1s in DIST area (Figure 2). Then enter into AGE setting mode, the AGE flashing to be set (Figure 3). Press the UP/DOWN to set age and press ENTER to confirm then go to Standby mode.

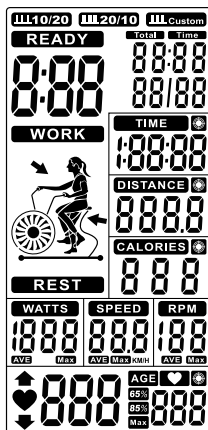

Figure 1

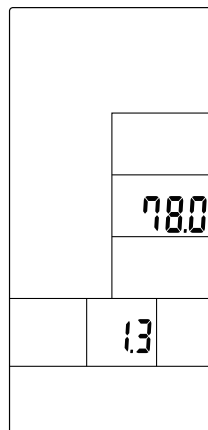

Figure 2

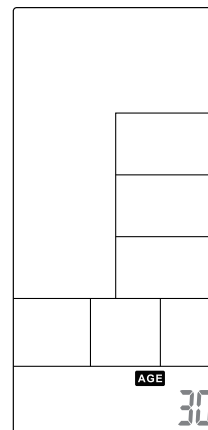



Figure 3

2. The window of **INTERVAL10/20** **INTERVAL20/10** **INTERVAL_CUSTOM** **READY** **WORK** **RESET** **TIME** **DISTANCE** **CALORIES** **WATT** **SPEED** **RPM** and  will flash by sequence in every 1s (Figure 4~Figure 16).

If no input of key operation or RPM signal or pulse input for 60s, computer will go to Sleeping mode.

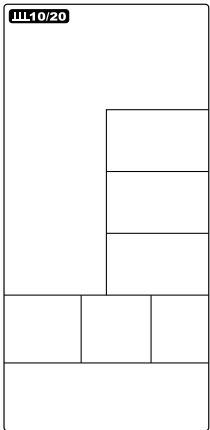

Figure 4

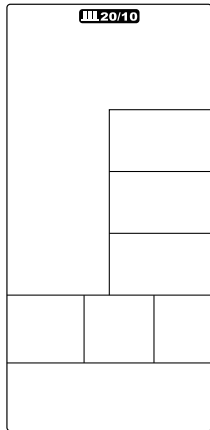

Figure 5

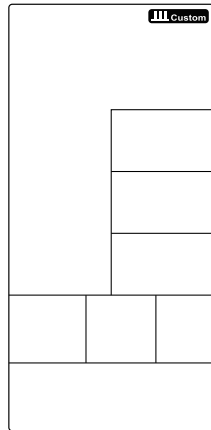

Figure 6

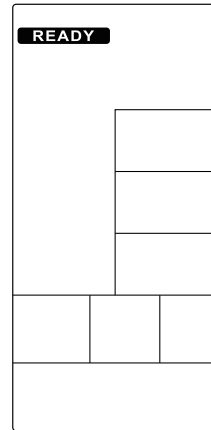

Figure 7

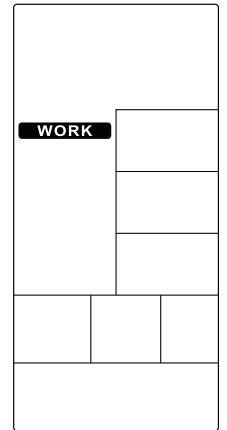

Figure 8

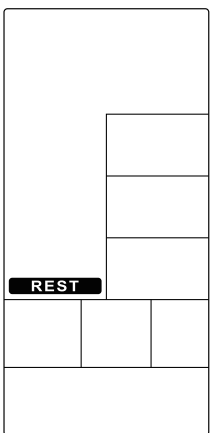

Figure 9

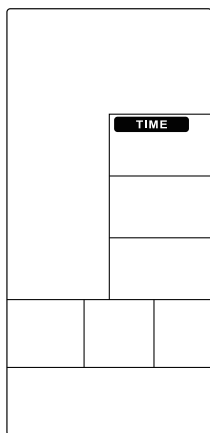

Figure 10

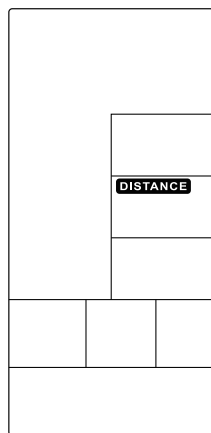

Figure 11

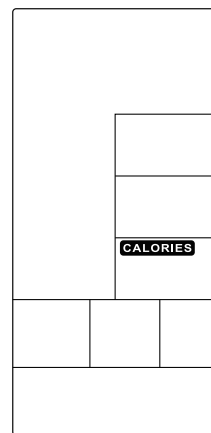

Figure 12

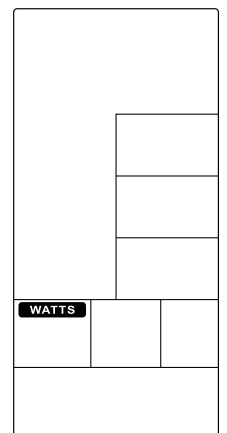

Figure 13

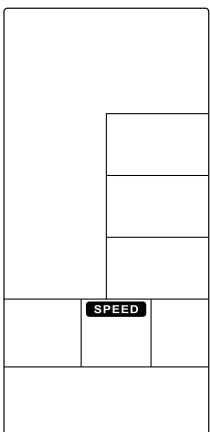

Figure 14

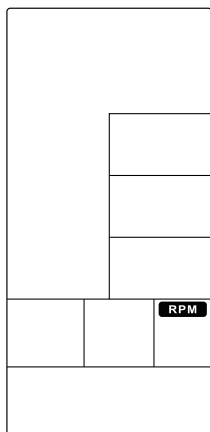

Figure 15

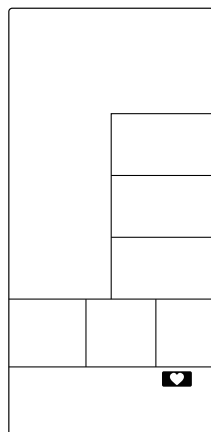

Figure 16

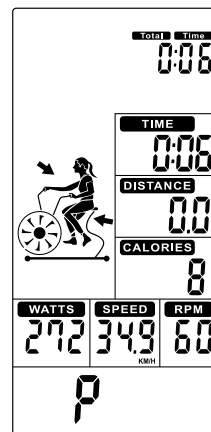

Figure 17

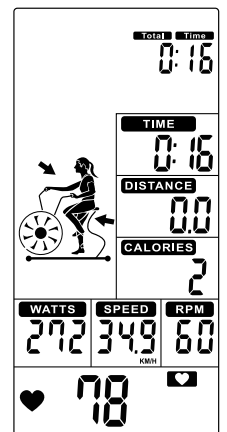

Figure 18

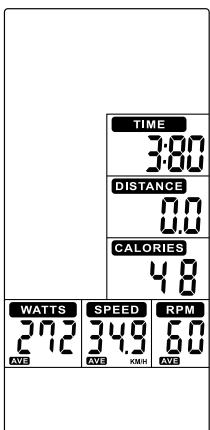

Figure 19

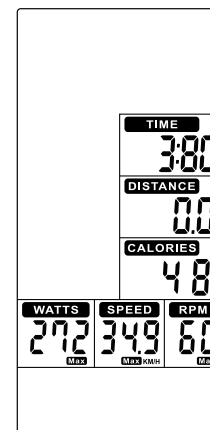

Figure 20

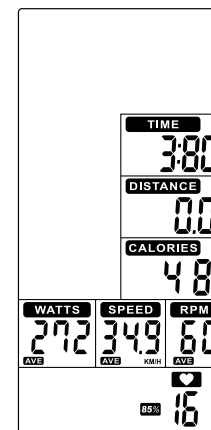

Figure 21

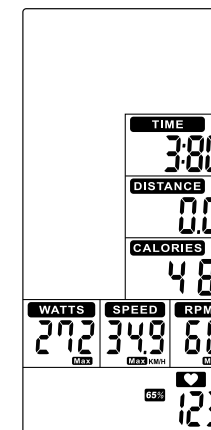

Figure 22

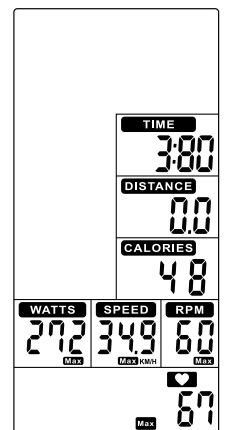



Figure 23



3. Select **Manual, Interval, Target Distance, Target Calories, Target HR, Target Time** program:

3.1 Manual mode:

- ① In Standby mode, press START to start workout quickly, the buzzer sound 1 second. TOTAL TIME/ TIME/ DISTANCE/ CALORIES/ WATTS/ SPEED/ RPM start to count up (Figure 17).
- ② Whenever there is Pulse signal input,  will light up and  symbol will flash and display pulsevalue (Figure 18). Without pulse input, it will display "P" (Figure 17).
- ③ No signal input for 30s, buzzer sounds 1 short beep and enter to Wake-up mode. Press any to wake up the console.
- ④ Press START key once to pause training, Buzzer will sound for 0.5s in every 30s. All values are displaying on LCD and flashing in every 4s. If continue to stop training for 5 minutes, buzzer sounds 2s and enter to Wake-up mode. Press START to resume workout.
- ⑤ Press STOP key, TIME will display total workout time; DISTANCE will display total workout distance; CALORIES will display totalconsumption during workout; WATT, SPEED and RPM will switch to display AVG. & MAX.PULSE window will switch to display 65%, 85% MAX (Figure 21~23) each 5s.
- ⑥ With pulse signal input, PULSE window will display user actual pulse. Pulse window displays nothing if no pulse signal input (Figure 19~20).
- ⑦ Press any PROGRAM key then perform the program accordingly.

3.2 Interval 20/10 mode:

- ① Press INIERVAL key to select INTERVAL20/10, press ENTER then INTERVAL20/10 will light up, alongwith a long sound for 1s.
- ② Cycle time counts down from 3 to 0 then console start, meanwhile buzzer beeps once per second and **READY** flashes once per second, counting displays '00/08'(Figure 24).
- ③ Cycle time counts down from 20 to 0 and **WORK** flashes once per second . Meantime windows displays rotation animation and count down from 4 minutes. Then TOTAL TIME, DISTANCE, CALORIES, WATTS, SPEED & RPM start calculating, counting displays '01/08'(Figure 25).
- ④ Cycle time counts down from 10 to 0 and **REST** flashes once per second along with 10 beeps(Figure 26), meanwhile **READY** willflash in last 3s (Figure 27).
- ⑤ The above ③&④ continue cycle counting and add 1 per each cycle,until displays 08/08**WORK** then go to End page.
- ⑥ Press START button once enter into PAUSE mode, Buzzer will sound for 0.5s in every 30s. All values are displaying on LCD and flashing in every 4s. If continue to stop training for 5 minutes, buzzer sounds 2s and enter to Wake-up mode. Press START to resume workout.
- ⑦ Press STOP or end up training, buzzer beeps 1s then displays TOTAL TIME, DISTANCE,CALORIES for 30s, and WATT, SPEED & RPM will switch to display AVG. & MAX. PULSE window will switch to display 65%, 85% MAX (Figure 21~23) each 5s.
- ⑧ With pulse signal input, PULSE window will display user actual pulse and 65%, 85% MAX (Figure 21~23). Pulse window displays nothing if no pulse signal input (Figure 19~20).
- ⑨ Press any PROGRAM key then perform the program accordingly.

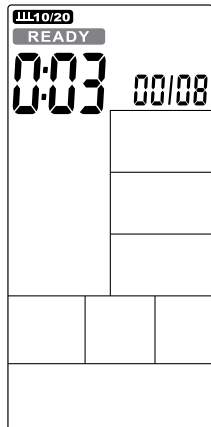

Figure 24

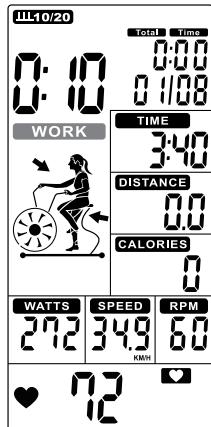

Figure 25

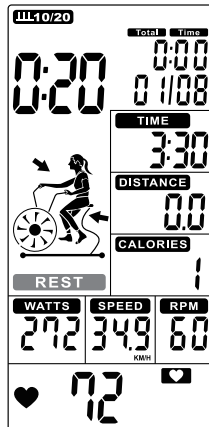

Figure 26

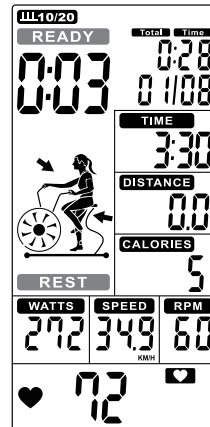

Figure 27

3.3 Interval 10-20 mode:

- ① Press INTERVAL to select INTERVAL10/20, press ENTER then **INTERVAL10/20** will light up along with buzzer beeps 1s.
- ② Cycle time counts down from 3 to 0 then console start, meanwhile buzzer beeps once per second and **READY** flashes once per second, counting displays '00/08'(Figure 28).
- ③ Cycle time counts down from 10 to 0 and **WORK** flashes once per second . Meantime REMAINING will light up and countdownfrom 4 minutes. ThenTOTAL TIME, DISTANCE, CALORIES, WATTS, SPEED & RPM start calculating, counting displays'01/08'(Figure 29).
- ④ Cycle time counts down from 20 to 0 and **REST** flashes once per second along with beeps (Figure 30), meanwhile **READY** will flashin last 3s (Figure 31).
- ⑤ The above ③&④ continue cycle counting and add 1 per each cycle, until displays 08/08 **WORK** , then go to End page.
- ⑥ Press START button once enter into PAUSE mode, Buzzer will sound for 0.5s in every 30s. All values are displaying on LCD and flashing in every 4s. If continue to stop training for 5 minutes, buzzer sounds 2s and enter to Wake-up mode. Press START to resume workout.
- ⑦ Press STOP or end up training, buzzer beeps 1s then displays TOTAL TIME, DISTANCE,CALORIES for 30s, and WATT, SPEED &RPM will switch to display AVG. & MAX. .PULSE window will switch to display 65%, 85% MAX (Figure 21~23) each 5s.
- ⑧ With pulse signal input, PULSE window will display user actual pulse. Pulse window displays nothing if no pulse signal input (Figure 19~20).
- ⑨ Press any PROGRAM key then perform the program accordingly.

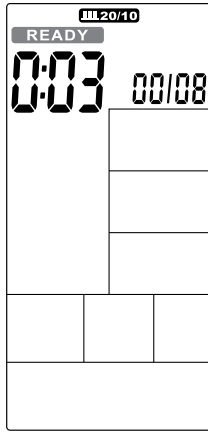

Figure 28

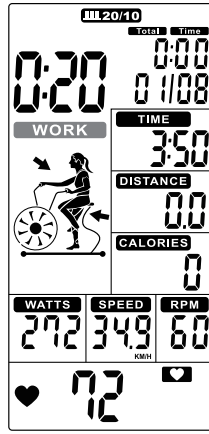

Figure 29



Figure 30

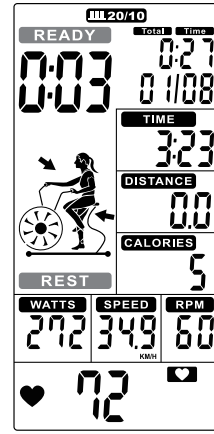

Figure 31

3.4 Interval CUSTOM:

- ① Press INTERVAL to select INTERVAL CUSTOM, press ENTER to enter into this mode then **INTERVAL CUSTOM** 00/XX flashes to be set along with buzzer beeps 1s. Press UP/DOWN to set 00/XX within 1~99 Circularly. Press ENTER to confirm along with buzzer beeps 1s then enter into next setting.(Figure 32)
- ② The TIME continues lighting up, **WORK** and 0:01 will flash, press UP/DOWN to set training time within 0:00~9:59 circularly (Figure 33). Press ENTER to confirm along with buzzer beeps 1s and **INTERVAL CUSTOM** continues lighting up.
- ③ The TIME continues lighting up, **REST** will flash, press UP/DOWN to set rest time 0:01~9:59 circularly (Figure 34). Press ENTER to confirm along with buzzer beeps 1s and **INTERVAL CUSTOM** continues lighting up.
- ④ Cycle time counts down from 3 to 0 then console start, meanwhile buzzer beeps once per second and **READY** flashes once per second, counting displays '00/XX'(Figure 35).
- ⑤ Cycle time counts down from the preset total time and **WORK** flashes once per second. Then TOTAL TIME, DISTANCE, CALORIES, WATTS, SPEED & RPM start calculating, counting displays '01/XX'(Figure 36).
- ⑥ Cycle time counts down from and **REST** flashes once per second along with buzzer beeps(Figure 37), meanwhile **READY** will flash in last 3s(Figure 38).
- ⑦ The above ③&④ continue cycle counting and add 1 per each cycle, until the WORK setting value finished then go to End page.
- ⑧ In **WORK** mode, buzzer beeps 1s then enter into wake up mode if no any signal inputs within 30s.
- ⑨ Press START button once enter into PAUSE mode, Buzzer will sound for 0.5s in every 30s. All values are displaying on LCD and flashing in every 4s. If continue to stop training for 5 minutes, buzzer sounds 2s and enter t Wake-up mode. Press START to resume workout.
- ⑩ Press START button or end up training, buzzer beeps 1s then displays TOTAL TIME, DISTANCE, CALORIES for 30s, and WATT, SPEED& RPM will switch to display AVG. & MAX. PULSE window will switch to display 65%, 85% MAX (Figure 21~23) each 5s.
- ⑪ With pulse signal input, PULSE window will display user actual pulse. Pulse window displays nothing if no pulse signal input (Figure 19~20).
- ⑫ Press any PROGRAM key then perform the program accordingly.

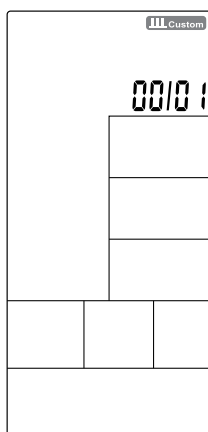

Figure 32

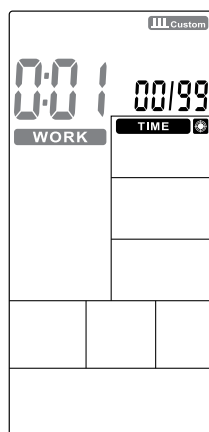

Figure 33

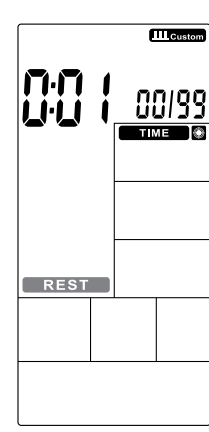

Figure 34

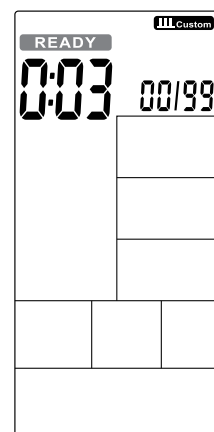

Figure 35

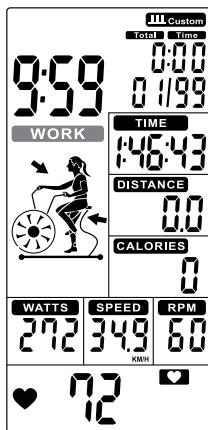

Figure 36

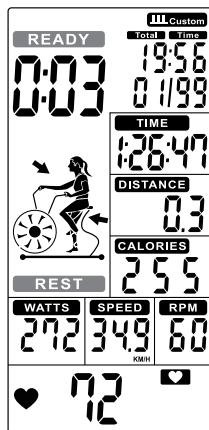

Figure 37



Figure 38

3.5 Target TIME mode:

- ① In Standby mode, press Target Time key and **TIME** will light up, along with a long sound for 1s.
- ② **TIME** value is flashing, press UP and DOWN to adjust (Figure 39) and press ENTER to confirm meanwhile buzzer beeps 1s and **TIME** lasting lighting up.
- ③ Preset **TIME** value counts down, **DISTANCE**, **CALORIES**, **WATTS**, **SPEED**, **RPM** start to count up. (Figure 40)
- ④ Press **START** button once enter into **PAUSE** mode, Buzzer will sound for 0.5s per second within 30s. All values are displaying on LCD and flashing in every 2s. If continue to stop training for 5 minutes, buzzer sounds 2s and enter to Wake-up mode. Press **START** to resume workout.
- ⑤ No signal inputs for 30s, buzzer sounds 1 short beep and enter to Wake-up mode.
- ⑥ Press **START** or end up training, **TIME** will display total workout time; **DISTANCE** will display total workout distance; **CALORIES** will display total consumption during workout; **WATT**, **SPEED** and **RPM** will switch to display **AVG.** & **MAX.** **PULSE** window will switch to display 65%, 85% **MAX** (Figure 21~23) each is.
- ⑦ With pulse signal input, **PULSE** window will display user actual pulse. Pulse window displays nothing if no pulse signal input (Figure 19~20).
- ⑧ Press any **PROGRAM** key then perform the program accordingly.

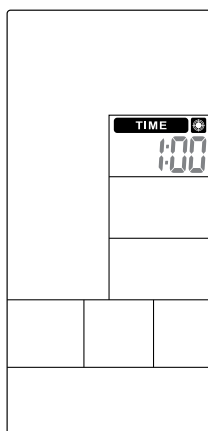

Figure 39

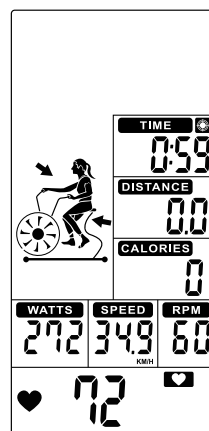

Figure 40

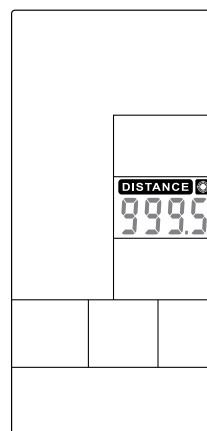

Figure 41

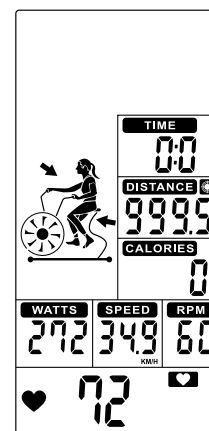

Figure 42

3.6 Target Distance mode:

- ① In Standby mode, press Target Distance key and **DISTANCE** will light up, along with a long sound for 1s.
- ② **DISTANCE** value is flashing, press UP and DOWN to adjust (Figure 41). Press ENTER to confirm meanwhile buzzer beeps 1s and **DISTANCE** lasting lighting up.
- ③ Preset **DISTANCE** value counts down, **TIME**, **CALORIES**, **WATTS**, **SPEED**, **RPM** start to count up. (Figure 42)
- ④ Press **START** button once enter into **PAUSE** mode, Buzzer will sound for 0.5s per second within 30s. All values are displaying on LCD and flashing in every 2s. If continue to stop training for 5 minutes, buzzer sounds 2s and enter to Wake-up mode. Press **START** to resume back workout.
- ⑤ No signal input for 30s, buzzer sounds 1s and enter to Wake-up mode.
- ⑥ Press **STOP** key or end up training, **TIME** will display total workout time; **DISTANCE** will display total workout distance; **CALORIES** will display total consumption during workout; **WATT**, **SPEED** and **RPM** will switch to display **AVG.** & **MAX.** **PULSE** window will switch to display 65%, 85% **MAX** (Figure 21~23) each 5s.
- ⑦ With pulse signal input, **PULSE** window will display user actual pulse. Pulse window displays nothing if no pulse signal input (Figure 19~20).
- ⑧ Press any **PROGRAM** key then perform the program accordingly.

3.7 Target Calories mode:

- ① In Standby mode, press Target Calories key and **CALORIES** will light up, along with a long sound for 1s.

- ② CALORIES value is flashing, press UP and DOWN to adjust (Figure 43). Press ENTER to confirm meanwhile buzzer beeps 1s and **CALORIES** lasting lighting up
- ③ Preset CALORIES value counts down, TIME, DISTANCE, WATTS, SPEED & RPM start to count up. (Figure 44).
- ④ Press START button once enter into PAUSE mode, Buzzer will sound for 0.5s per second within 30s. All values are displaying on LCD and flashing in every 2s. If continue to stop training for 5 minutes, buzzer sounds 2s and enter Wake-up mode. Press START to resume workout.
- ⑤ No signal input for 30s, buzzer sounds 1s and enter to Wake-up mode.
- ⑥ Press STOP key or end up training, TIME will display total workout time; DISTANCE will display total workout distance; CALORIES will display total consumption during workout; WATT, SPEED and RPM will switch to display AVG. & MAX. PULSE window will switch to display 65%, 85% MAX (Figure 21~23) in each.
- ⑦ With pulse signal input, PULSE window will display user actual pulse. Pulse window displays nothing if no pulse signal input (Figure 19~20).
- ⑧ Press any PROGRAM key then perform the program accordingly.

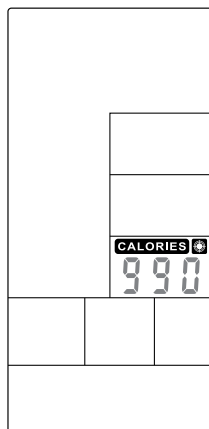

Figure 43

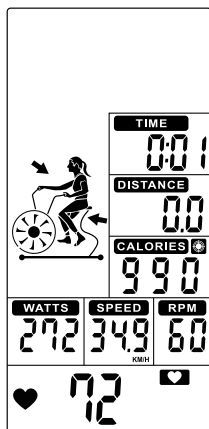

Figure 44

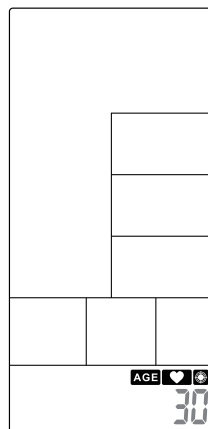

Figure 45

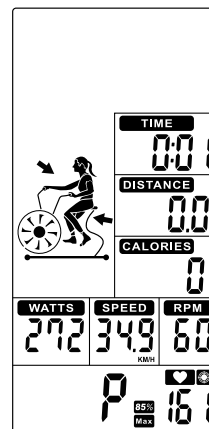

Figure 46

3.8 Target HR mode:

- ① In Standby mode, press Target Heart-Rate key and **AGE** will light up, along with along sound for 1s.
 - ② AGE value is flashing, press UP and DOWN to preset your Age (Figure 45). Press ENTER to confirm along with buzzer beeps 1S and HEART RATE last lighting up.
 - ③ When start workout, **MAX HR** lights up, 65% & 85% Heart rate will switch to display. TIME/ DISTANCE/ CALORIES/ WATTS/SPEED/ RPM will calculate workout value (Figure 46).
 - ④ When Heart Rate goes below to 65%, & **65%** & value will flash. And buzzer sounds in every 10s until user HR achieve above 65% (Figure 47).
 - ⑤ When Heart Rate exceeds to 85%, & **85%** & value will flash. And buzzer sounds in every 10s until user HR goes below 85% (Figure 48).
 - ⑥ When Heart Rate goes between 65% ~ 85%, only will flash (Figure 49).
 - ⑦ No signal input for 30s, buzzer sounds 1 short beep and enter to Wake-up mode.
 - ⑧ Press START button once enter into PAUSE mode, Buzzer will sound for 0.5s per second within 30s. All values are displaying on LCD and flashing in every 2s. If continue to stop training for 5 minutes, buzzer sounds 2s and enter to Wake-up mode. Press START to resume workout.
 - ⑨ Press STOP again or end up training in 15s, TIME will display total workout time; DISTANCE will display total workout distance; CALORIES will display total consumption during workout; WATT, SPEED and RPM will switch to display AVG. & MAX. PULSE window will switch to display 65%, 85% MAX (Figure 21~23) each 5s.
 - ⑩ With pulse signal input, PULSE window will display user actual pulse. Pulse window displays nothing if no pulse signal input (Figure 19~20).
- * Press any PROGRAM key then perform the program accordingly.

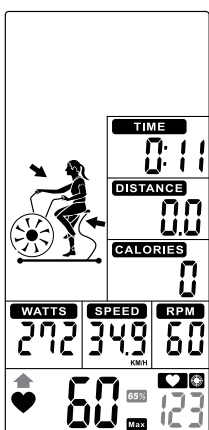

Figure 47

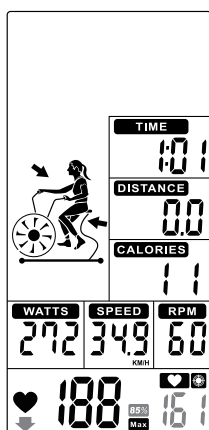

Figure 48

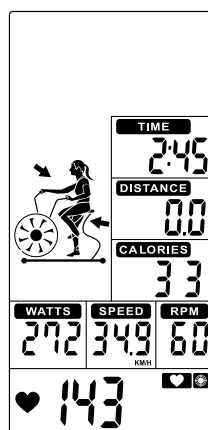

Figure 49

OPTION SETTING: SETTING mode-

1. Hold on START&ENTER key for 2s, buzzer will sound 1 long beep. SPEED keep lighting up, M/H,KM/H flash once per second (Figure 50~51).
2. Press UP or DOWN to select KM/H or M/H, press ENTER to confirm then skip to Standby mode.
3. No action to console for 30s, it will go to Standby mode.

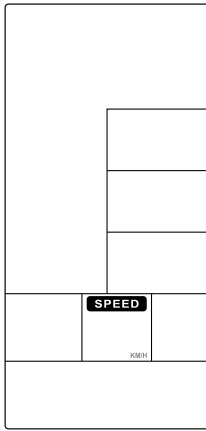

Figure 50

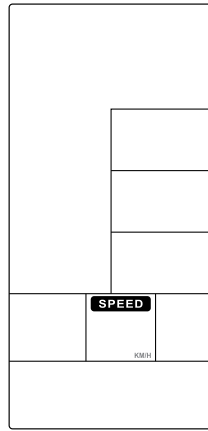

Figure 51

RESET mode-

1. In any mode, press STOP for 2s, system will do TOTAL RESET.
2. LCD flash in every 2 seconds, buzzer sound for 2 seconds.
3. Reverse to Standby page, all setting resume to preset value.

SLEEPING mode-

In Standby mode, if no key press/RPM/pulse input for 30s, console will go to SLEEPING mode.

Exploded Diagram

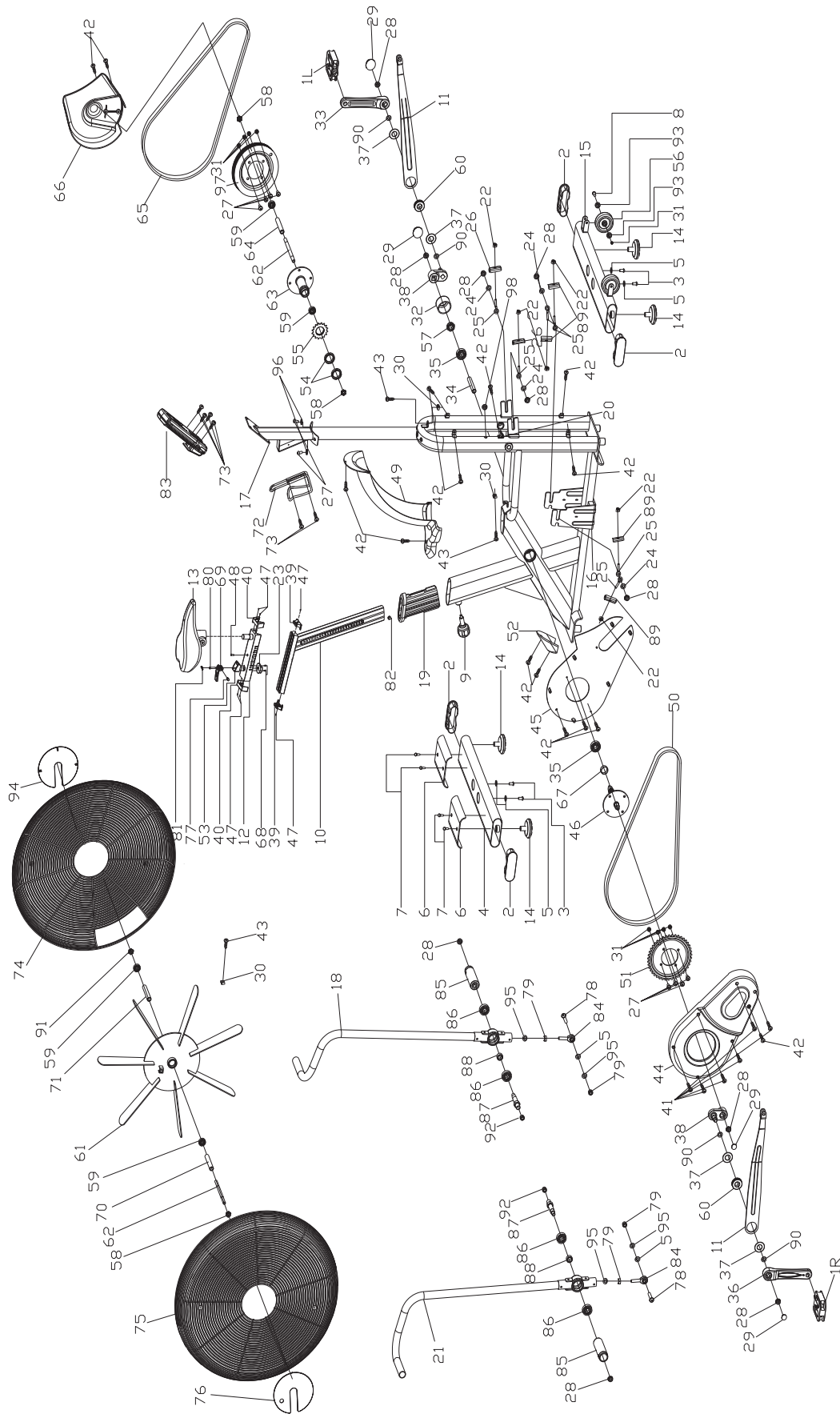

Part List

NO.	DESCRIPTION OF PARTS	QTY
1	Pedal	1
2	End cap3	4
3	Bolt 1	4
4	Rear stabilizer	1
5	Flat washer	6
6	Front cover	2
7	Bolt 1	4
8	Bolt 2	2
9	Shape knob	1
10	Vertical seat post	1
11	Drive assembly	2
12	Seat post	1
13	Seat	1
14	Stopper	4
15	Front stabilizer	1
16	Main frame	1
17	Electronic watch connecting assembly	1
18	The left handlebar assembly	1
19	Plastic sleeve	1
20	Sensor	1
21	Right handlebar assembly	1
22	Nut	6
23	Fixing nut 2	1
24	Flat washer	4
25	Fixing bolt	2
26	Pull out the fixed piece	2
27	Bolt 1	10
28	Nut	10
29	Crank end cap	4
30	Sprocket buckle	9
31	Nut	10
32	Plastic ring	1
33	Left crank	1
34	Long fixing tube	1
35	Bearing	2
36	Right crank	1
37	Outer spring	4
38	Crank drive assembly	2

39	Cover	2
40	Cover	2
41	Screw 1	6
42	Screw 2	18
43	Screw 3	6
44	Chain cover 1	1
45	Chain cover 2	1
46	Axis	1
47	Bolt 7	6
48	Bolt 8	1
49	Sweat proof cover	1
50	Short chain wheel	1
51	Belt wheel	1
52	Front cover	1
53	Handle base	1
54	Lock nut	2
55	Chain wheel 1	1
56	Wheel	2
57	Fixing nut	1
58	Fixing nut 2	3
59	Bearing	4
60	Bearing	2
61	Rim assembly	1
62	Flywheel shaft	2
63	Double drive assembly	1
64	Double drive inner sleeve	1
65	Belt	1
66	Chain cover 3	1
67	Short fixing tube	1
68	Bolt 1	2
69	Handle	1
70	Flywheel outer tube	1
71	Flywheel inner casing	1
72	Bottle holder	1
73	Screw 3	6
74	The left wheel cover	1
75	Right wheel cover	1
76	Fan baffle	1
77	Handle rotary copper sleeve	1

78	Bolt 3	2
79	Nut	2
80	Bolt 16	1
81	Handle cover	1
82	Nut	2
83	Computer	1
84	Universal joint	2
85	Foot lever	2
86	Bearing	4
87	Foot lever	2
88	Foot lever bushing	2
89	Small retaining plate	4
90	Corrugated gasket	4
91	Fixing nut 1	1
92	Nut	2
93	Bearing	4
94	Fan baffle	1
95	Spring washer	2
96	Spring washer 2	10
97	Belt wheel	1
98	Plastic plug	1
99	Fixing bolt	4